

DENSO

BHT-300BWB Bar Code Handy Terminal

Operator's Guide

This guide has been prepared expressly for the hands-on user. Always keep it nearby for speedy reference.

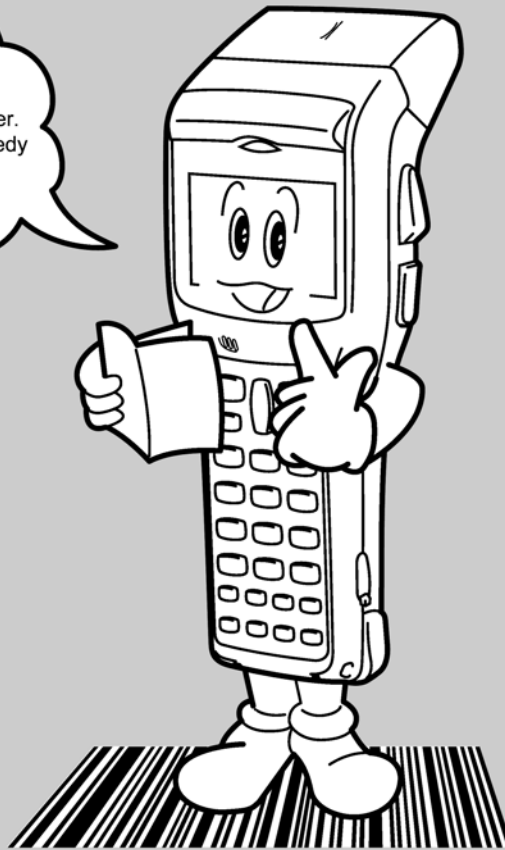

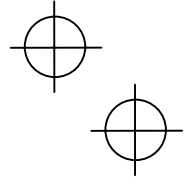
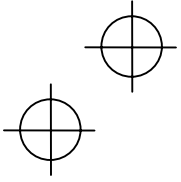

- DENSO WAVE INCORPORATED does not assume any product liability arising out of, or in connection with, the application or use of any product, circuit, or application described herein.
- If it is judged by DENSO WAVE INCORPORATED that malfunction of the product is due to the product having been dropped or subjected to impact, repairs will be made at a reasonable charge even within the warranty period.
- Intellectual Property Precaution
DENSO WAVE INCORPORATED ("DENSO WAVE") takes reasonable precautions to ensure its products do not infringe upon any patent or other intellectual property rights of other(s), but DENSO WAVE cannot be responsible for any patent or other intellectual property right infringement(s) or violation(s) which arise from (i) the use of DENSO WAVE's product(s) in connection or in combination with other component(s), product(s), data processing system(s) or equipment or software not supplied from DENSO WAVE; (ii) the use of DENSO WAVE's products in a manner for which the same were not intended nor designed; or (iii) any modification of DENSO WAVE's products by other(s) than DENSO WAVE.

Bluetooth® is a trademark owned by its proprietor. DENSO WAVE uses Bluetooth® wireless technology under license.

Related Publications

BHT-300BWB User's Manual (Contained in the Manual Pack CD. Download available at our URL printed on the back cover of this operator's guide.)

Instructions for using the handy terminal (BHT-300BWB) and optical communication unit (CU-300).

BHT-BASIC Programmer's Manual (BHT-300 series)
(Contained in the BHT-BASIC Compiler CD and Manual Pack CD)

Description for developing application programs of the handy terminal in BHT-BASIC.

BHT-BASIC 4.0 Transfer Utility Guide (that comes with BHT-BASIC 4.0 Transfer Utility)
Description about software that transmits data and programs between the handy terminal and computer.

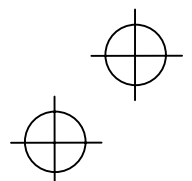
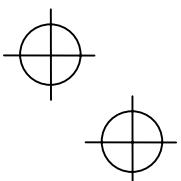

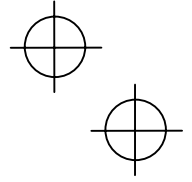
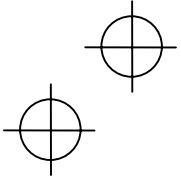

Related Publications

BHT-300BWB User's Manual (Contained in the Manual Pack CD. Download available at our URL printed on the back cover of this operator's guide.)

Instructions for using the handy terminal (BHT-300BWB) and optical communication unit (CU-300).

BHT-BASIC Programmer's Manual (BHT-300 series)

(Contained in the BHT-BASIC Compiler CD and Manual Pack CD)

Description for developing application programs of the handy terminal in BHT-BASIC.

BHT-BASIC 4.0 Transfer Utility Guide (that comes with BHT-BASIC 4.0 Transfer Utility)

Description about software that transmits data and programs between the handy terminal and computer.

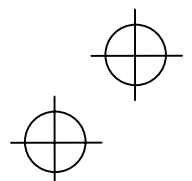
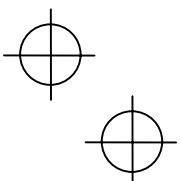

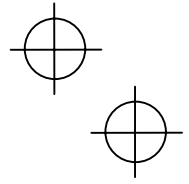
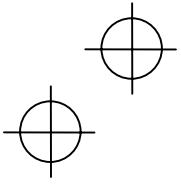

Contents

SAFETY PRECAUTIONS	5
Components and Functions	9
Reading 2D Codes and Bar Codes	11
Using Radio Link and Bluetooth® Wireless Communication Link	13
Using Infrared Link	14
Setting the Backlight	15
Adjusting the LCD Contrast & Beeper Volume and Switching the Beeper & Vibrator	16
Displaying the Battery Voltage Level	17
Loading the Battery Cartridge	18
Battery Replacement Notes	19
BHT Turning-off Notes	20
Error Messages	21
Proper Care of the BHT	26
Handling Notes	27
US and Canada Regulations	28
Labeling	29
Customer Registration Form	30

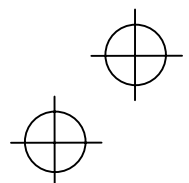
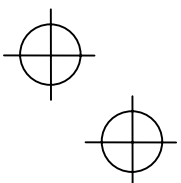

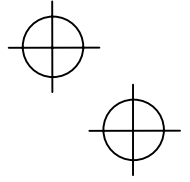
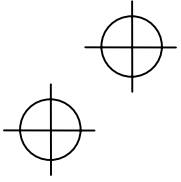

SAFETY PRECAUTIONS

Be sure to observe all these safety precautions.

Strict observance of these warnings and cautions is a **MUST** for preventing accidents that could result in bodily injury and substantial property damage. Make sure you fully understand all definitions of these terms and symbols given below before you proceed to the text itself.

WARNING

Alerts you to those conditions that could cause serious bodily injury or death if the instructions are not followed correctly.

CAUTION

Alerts you to those conditions that could cause minor bodily injury or substantial property damage if the instructions are not followed correctly.

Meaning of Symbols



A triangle (\triangle) with a picture inside alerts you to a warning of danger. Here you see the warning for electrical shock.



A diagonal line through a circle (\odot) warns you of something you should not do; it may or may not have a picture inside. Here you see a screwdriver inside the circle, meaning that you should not disassemble.



A black circle (\bullet) with a picture inside alerts you to something you **MUST** do. This example shows that you **MUST** unplug the power cord.

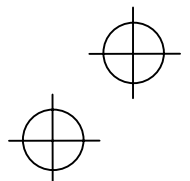
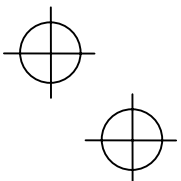

 **WARNING****To System Designers:**

- When introducing BHTs in those systems that could affect human lives (e.g., medicines management system), develop applications carefully through redundancy and safety design which avoids the feasibility of affecting human lives even if a data error occurs.

**Handling the battery cartridge**

- Never disassemble or heat the battery cartridge, nor put it into fire or water; doing so could cause battery-rupture or leakage of battery fluid, resulting in a fire or bodily injury.
- Do not carry or store the battery cartridge together with metallic ball-point pens, necklaces, coins, hairpins, etc.
Doing so could short-circuit the terminal pins, causing the batteries to rupture or the battery fluid to leak, resulting in a fire or bodily injury.
- Avoid dropping the battery cartridge or letting it undergo any shock or impact.
Doing so could cause the batteries to break, generate heat, rupture or burn.
- Only use the dedicated charger for charging the battery cartridge.
Using a different type of charger could cause battery-rupture or leakage of battery fluid and result in a fire, bodily injury, or serious damage to property.
- Never charge the battery cartridge where any inflammable gases may be emitted; doing so could cause fire.



! WARNING

Handling the BHT

- The BHT uses a laser light for indicating the scanning range. The intensity of the laser light might be too low to inflict bodily injury. However, do not look into the laser beam.



The BHT complies with IEC 60825-1:1993+A2:2001 and 21 CFR 1040.10, 1040.11 except for deviations pursuant to laser notice No. 50, dated July 26, 2001.

In accordance with Clause 5, IEC 60825-1, the following information is provided to the user:

LASER LIGHT
DO NOT STARE INTO BEAM
CLASS 2 LASER PRODUCT

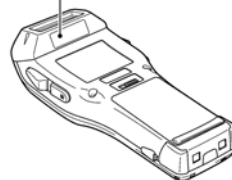

Caution - Use of controls or adjustments or performance of procedures other than those specified herein may result in hazardous laser light exposure.

! CAUTION

Handling the battery cartridge

- Never charge a wet or damp rechargeable battery cartridge. Doing so could cause the batteries to break, generate heat, rupture or burn.











Handling the BHT

- Never put the BHT in places where there are excessively high temperatures, such as inside closed-up automobiles, or in places exposed to direct sunlight. Doing so could affect the housing or parts, resulting in a fire.
- Avoid using the BHT in extremely humid or dusty areas, or where there are drastic temperature changes. Moisture or dust will get into the BHT, resulting in malfunction, fire or electrical shock.



⚠ CAUTION

- Never disassemble or modify the BHT; doing so could result in an accident such as break or fire.  Never disassemble
- If smoke, abnormal odors or noises come from the BHT, immediately turn off the power, pull out the battery cartridge, and contact your nearest dealer. Failure to do so could cause smoke or fire. 
- If foreign material or water gets into the BHT, immediately turn off the power, pull out the battery cartridge, and contact your nearest dealer. Failure to do so could cause smoke or fire. 
- If you drop the BHT so as to damage its housing, immediately turn off the power, pull out the battery cartridge, and contact your nearest dealer. Failure to do so could cause smoke or fire. 
- Do not use batteries or power sources other than the specified ones; doing so could generate heat or cause malfunction. 
- In environments where static electricity can build into significant charges (e.g., if you wipe off the plastic plate with a dry cloth), do not operate the BHT. Doing so will result in malfunction or machine failure. 
- When connecting or disconnecting the direct-connect interface cable to/from the BHT, do not plug or unplug at an angle and do not pull the cable strongly. Doing so will result in a machine failure. 
- If the BHT has been stored in a hot (50°C to 60°C, 122°F to 140°F) and humid place, allow it to sit at room temperature and humidity for at least one day before use. Using the BHT with its inside being hot will fail to scan or result in a machine failure. 

■ Limited Warranty on Software Products

In no event will DENSO WAVE INCORPORATED be liable for direct, indirect, special, incidental, or consequential damages (including imaginary profits or damages resulting from interruption of operation or loss of business information) resulting from any defect in the software or its documentation or resulting from inability to apply the software or its documentation.

Components and Functions

Liquid crystal display (LCD)
Shows the characters and graphic patterns.

Indication LED

Illuminates in green when the BHT has successfully read a 2D code or bar code.

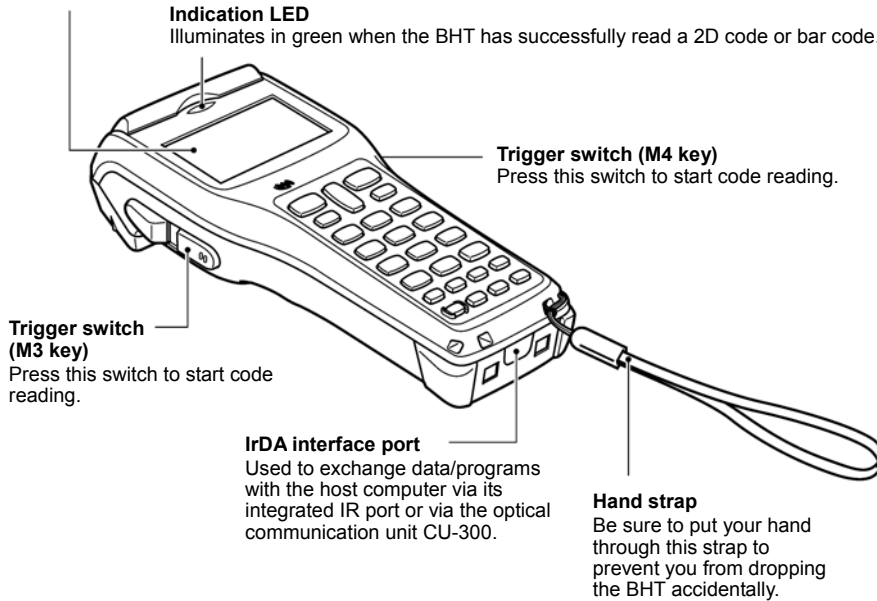

Reading window

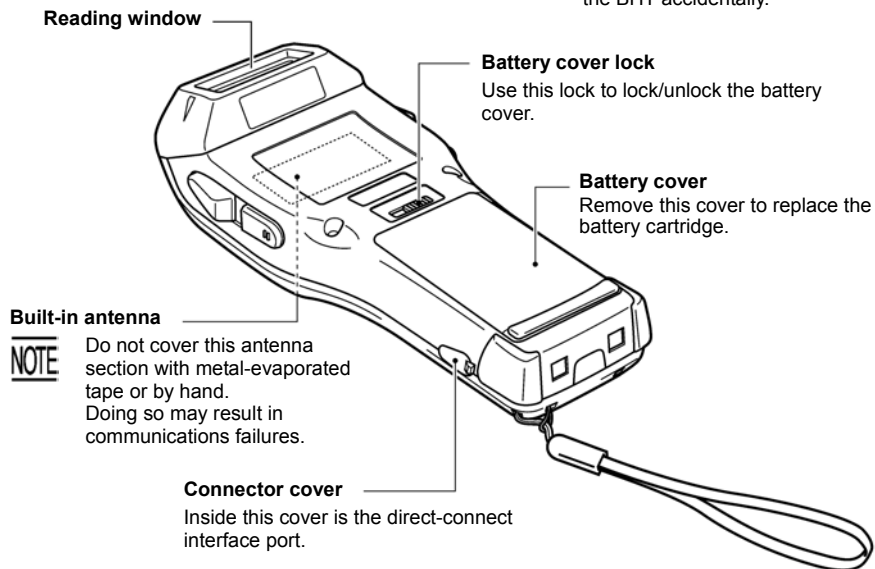

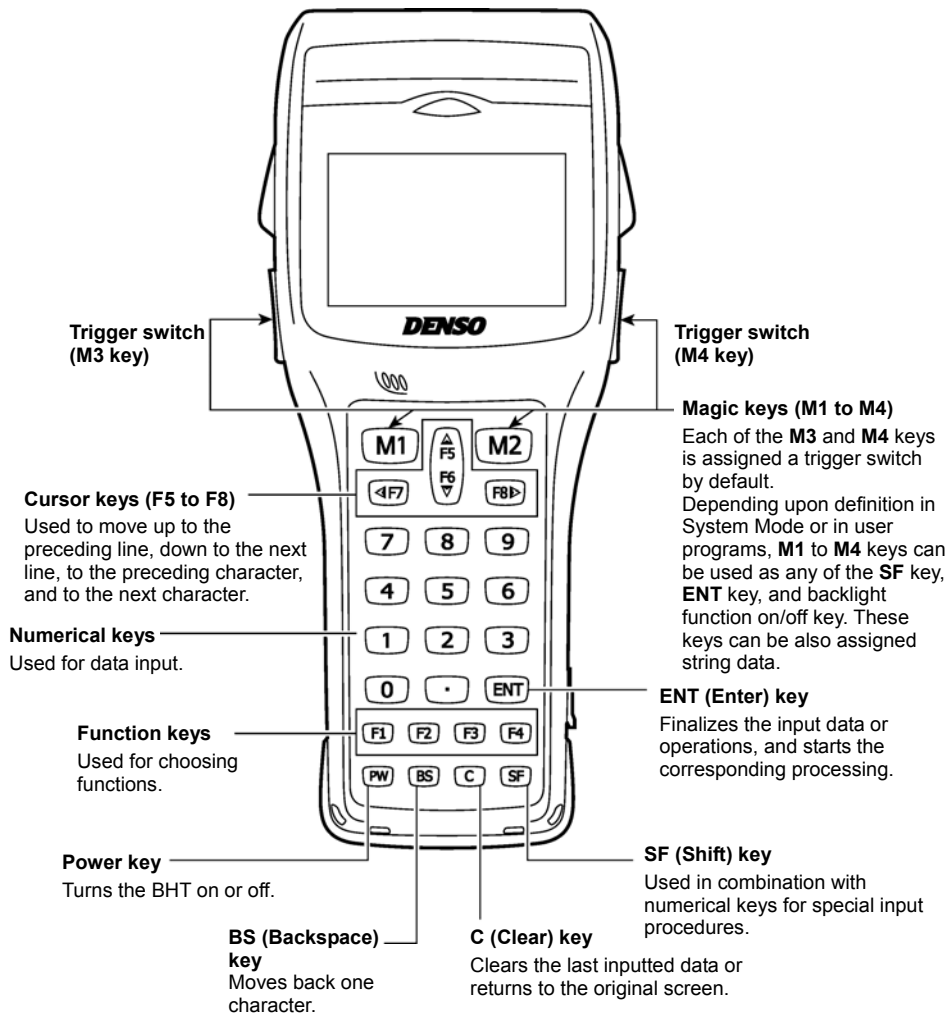

Reading 2D Codes and Bar Codes

Turn the BHT on, bring the reading window to a 2D code or bar code to be scanned, and press the trigger switch. The BHT turns the marker beam (laser) and illumination LED on to indicate the scanning range and scan the target code, respectively.

When the BHT has read the code successfully, the indicator LED illuminates in green and the marker beam goes off.

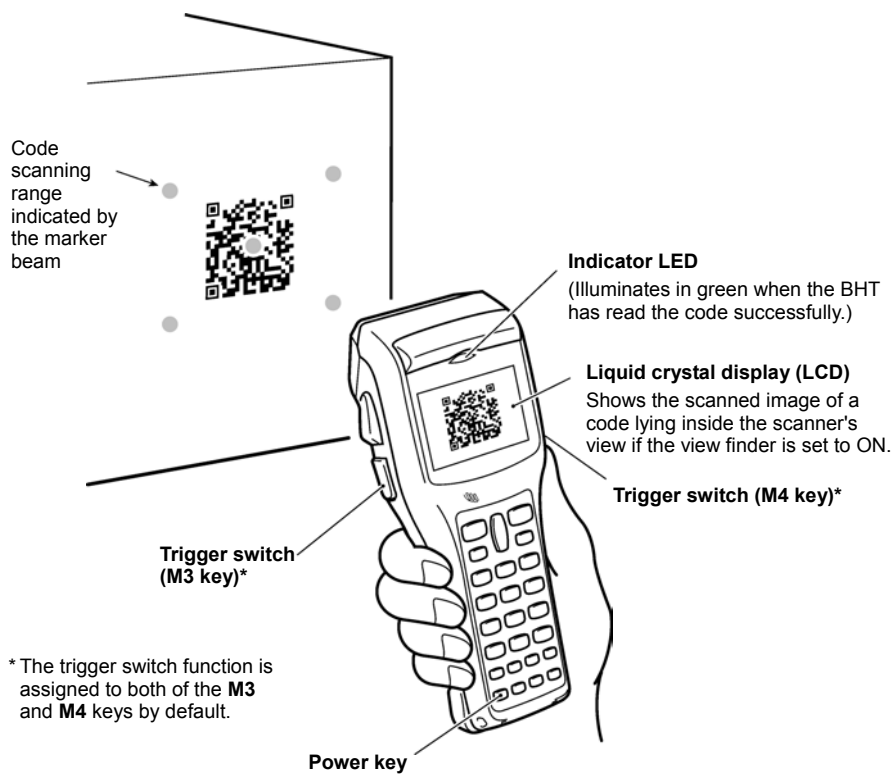

- If the BHT fails to read due to specular effects or other factors, change the scanning angle of the reading window or the distance from codes as shown at right, and try it again. (Specular effects occur when the reflection of the light from the code becomes excessively strong. This can easily happen when the reflecting surface is polished or covered with vinyl.)

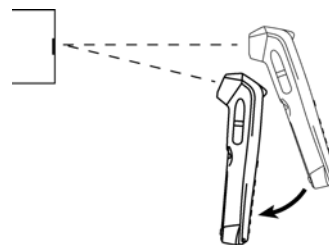

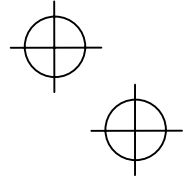
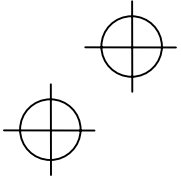

12

- The actual scanning range is narrower than the marker beam range. The scanning range is 2.4" (6 cm) wide by 1.6" (4 cm) high when the scanning distance is approx. 4.3" (11 cm).
- The code reading procedure may differ depending upon the application used, so follow the application's manual.

NOTE

- Before reading labels, clean them if stained.
- Avoid using the BHT in direct sunlight. The BHT might fail to read correctly.
- To read 2D codes or bar codes on curved surfaces, apply the BHT to the target code so that the code comes to the center of the scanning range indicated by the marker beam.
- Depending upon the code size or cell pitch, the proper scanning distance from codes will differ.
- The marker beam range should only be used as a guide. It does not assure that a code within the marker beam range can be read.

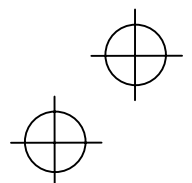
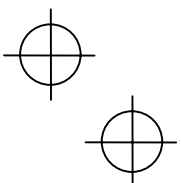

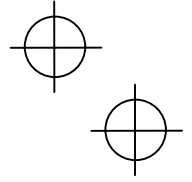
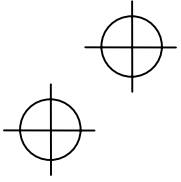

Using Radio Link and Bluetooth® Wireless Communication Link

The BHT-300BWB supports Bluetooth® wireless data communication.

- If there are too many communications errors, first make sure that the BHT shall be directed at the target Bluetooth® wireless communication equipment such as an access point because the 2.4 GHz band requires a more or less straight line path. Note also that the low-power radio waves have trouble passing through human bodies and other obstacles along that path.
- The communication link will not operate properly in the vicinity of microwave ovens, industrial heaters, high-frequency medical equipment, wireless LAN-enabled devices, and other sources of radio waves in the 2.4 GHz band.
- Electromagnetic noise from personal computers, refrigerators, and other home appliances can also interfere with link operation.
- Environmental factors that can also interfere with link operation include large metallic objects, metallic dust, or metallic walls in the vicinity of the path and vibration at either end.

NOTE To System Designers:

- Before developing the application, make sure that the intended environment is free of the interference factors above and thus actually capable of supporting link operation.
- Assume that there will be communications failures requiring robust retry capabilities in the software.
- When introducing the BHT link operation into an environment where equipment using radio waves in the 2.4 GHz band operates or when introducing such equipment after the introduction of the BHT link operation, be sure to confirm that the BHT radio link operates properly with all equipment being in operation beforehand.
- If the environment of the radio communications system is changed after the introduction (e.g., newly installed household appliances and movement/addition of shelves or objects), then confirm that the radio link operates properly again before the actual use.

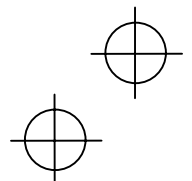
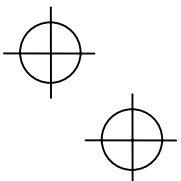

Using Infrared Link

■ Communicating with the CU

Put the BHT directly on the CU as shown below.

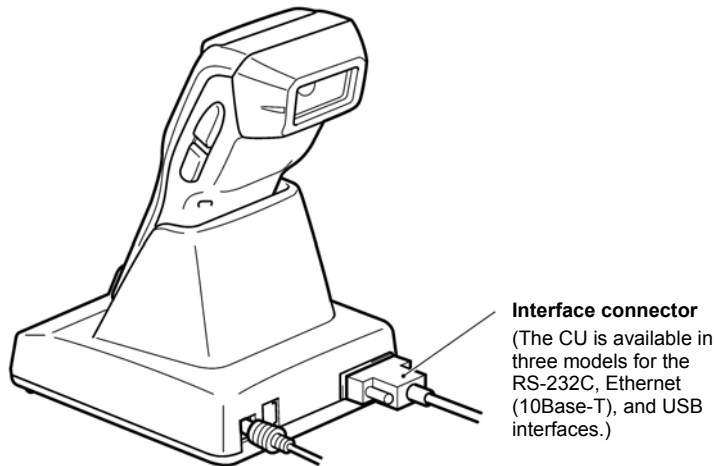

■ Communicating with other IrDA-compliant equipment

You can also have the BHT communicate with other IrDA-compliant equipment just by aligning their IR ports with each other. The effective IR range and IR port angle may differ depending upon the target equipment, so observe the instructions given in manuals furnished with such equipment.

NOTE Shield the IrDA interface from direct sunlight, intense overhead lighting (inverter-driven fluorescent lighting, in particular), and other potential sources of infrared radiation. Sources to watch out for include remote control units for television sets and the like.

Setting the Backlight

Pressing the **M4** key (right-hand trigger switch) while holding down the **SF** (Shift) key activates or deactivates the backlight function.

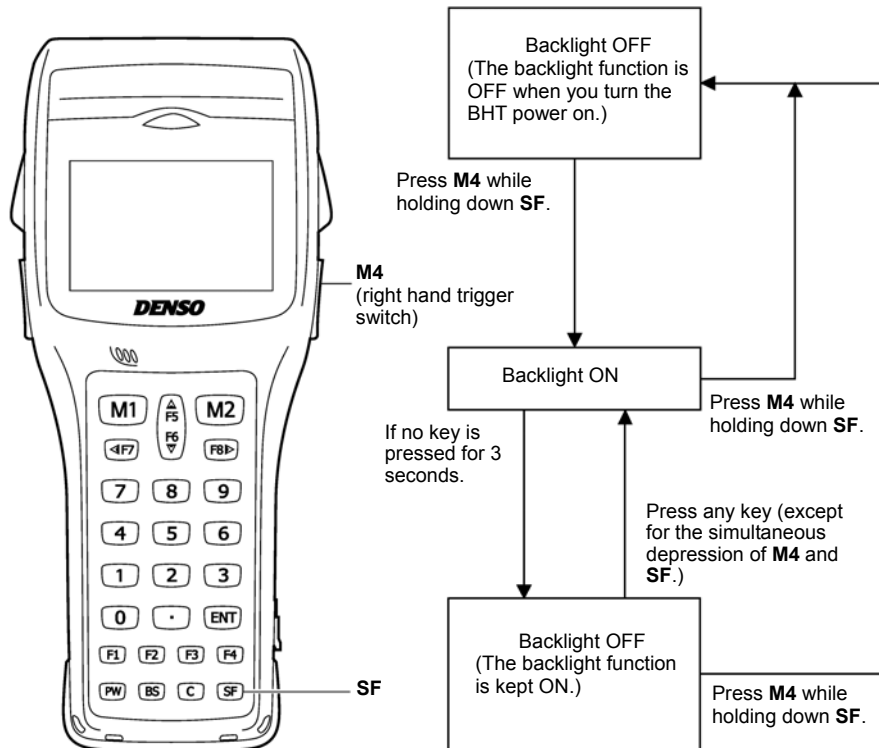

NOTE In user programs, you can select the key to be used for activating or deactivating the backlight function (instead of the initial setting: combination of **SF** and **M4** key (right-hand trigger switch)), as well as modifying the ON-duration of the backlight before the automatic turning-off.

Adjusting the LCD Contrast & Beeper Volume and Switching the Beeper & Vibrator

While holding down the **M1** or **M4** key (right-hand trigger switch), press the **PW** key, and the following screen will appear on the LCD. This screen will disappear if no keys are pressed for five seconds.

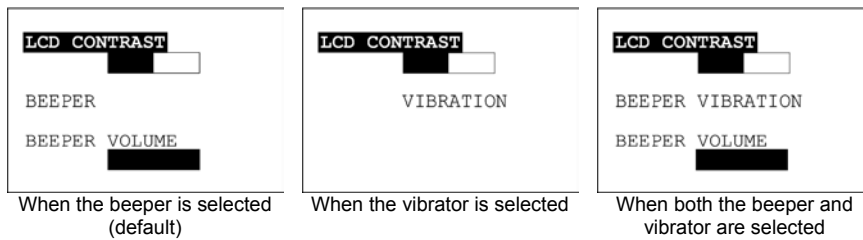

(The current selection is highlighted.)

Adjusting the LCD contrast

You can adjust the LCD brightness to eight contrast levels.

- (1) Use the **F5** and **F6** keys to select the LCD CONTRAST line.
- (2) To decrease the contrast, press the **F7** key; to increase it, press the **F8** key.

Switching the beeper & vibrator

You may choose any of three ways—beeping only, vibrating only, or beeping & vibrating as a confirmation of completion of code reading.

- (1) Use the **F5** and **F6** keys to select the BEEPER VIBRATION line that will be highlighted in any one of the following three states:



- (2) Highlight the desired way(s) by using the **F7** and **F8** keys, referring to the above figure.

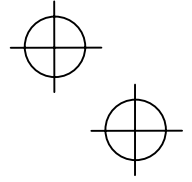
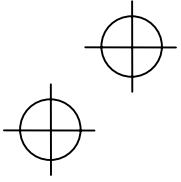

Adjusting the beeper volume

You can adjust the beeper volume to four levels from OFF to MAX.

- 1) Use the **F5** and **F6** keys to select the BEEPER VOLUME line.
- 2) To turn down the volume, press the **F7** key; to turn it up, press the **F8** key.

After making the above setting, press the **ENT** key or no keys for five seconds. The new settings will be fixed and the above screen will disappear.

Displaying the Battery Voltage Level

On the SYSTEM MENU or during execution of user programs, press the **ENT** key while holding down the **SF** key for displaying the battery voltage level.

As long as you hold down those keys, the following screen is displayed.

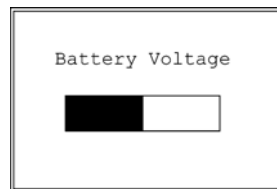

REFERENCE In user programs, you can select the key to be used for displaying the battery voltage level (instead of the default: combination of **SF** and **ENT**).

The displayed battery level shows the terminal voltage of the battery, not how much power is left.

The battery voltage level varies depending upon the operation of the BHT, so the displayed level also may vary by about 1 to 2 levels.

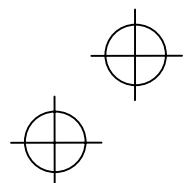
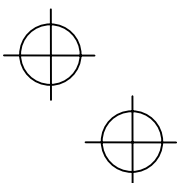

Loading the Battery Cartridge

Before the first use of the BHT, be sure to load the battery cartridge as shown below. The battery cartridge is not loaded in the BHT when shipped from the factory.

Loading the battery cartridge

- (1) Turn the BHT upside down.
- (2) As shown below, slide the battery cover lock in the direction of the arrow and remove the battery cartridge cover.
- (3) Check the polarity (positive and negative) of the battery cartridge. Then, load it so that the end of the battery pull strap appears above the battery cartridge as shown below. This facilitates easy removal of the battery cartridge.
- (4) Put the battery cartridge cover back into place taking care not to pinch the battery pull strap between its cover and the bottom cover. Then, return the battery cover lock to its original position.
- (5) Place the BHT on the CU-300 to charge the battery cartridge.

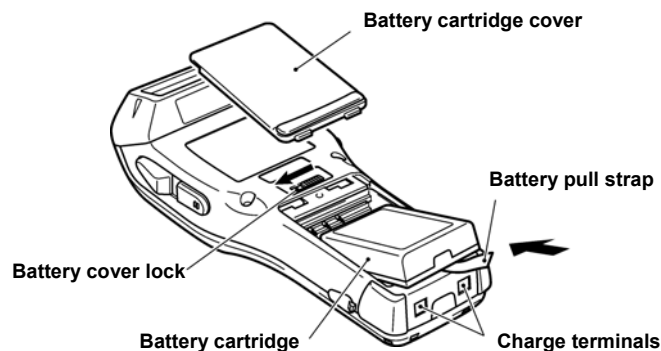

TIP The BHT has an integrated rechargeable backup power source which backs up the memory and calendar clock in the BHT when no battery cartridge is loaded or the voltage level drops below the specified level. The backup power source is automatically charged by the battery cartridge.

- NOTE**
- When you first load battery cartridge after purchase or you load it after leaving the BHT unused for a long time, do not remove the battery cartridge for at least 10 minutes after that loading. This is for charging the memory backup source integrated in the BHT.
 - If you leave the BHT without the charged battery cartridge loaded for a long time, the memory contents will no longer be backed up so that the message "Contact your administrator. Note the error number. (XXXX)" or "Set the current date and time." may appear on the LCD.
 - If you will not be using the BHT for a long time, follow the instructions given in the "Battery Replacement Notes" on the next page.

Battery Replacement Notes

■ When is battery replacement needed?

If the "Charge the battery!" appears on the LCD, replace the battery cartridge with a fully charged one.

If you leave the BHT without replacing the battery cartridge, the integrated calendar clock or data will no longer be backed up so that the calendar clock will stop or the "Contact your administrator. Note the error number. (XXXX)" will appear on the LCD.

NOTE Be sure to turn the BHT off before battery replacement.

Replace the battery cartridge quickly. Load the battery cartridge within 3 minutes after the removal to avoid data loss.

After battery replacement, turn the BHT on and check its operation.

■ If you will use the BHT more than one time per month:

Keep the battery cartridge loaded in the BHT.

■ If you will not be using the BHT for more than one month:

Remove the battery cartridge from the BHT and then store the BHT. To do so, be sure to follow the procedure given below.

(1) When removing the battery cartridge:

Press the **PW** key for more than 3 seconds to turn the BHT off.

The following message will appear on the LCD and the BHT will start backing up data. After completion of the backup operation so that the message disappears, remove the battery cartridge.

(The backup operation may take several tens of seconds depending upon the volume of data to be backed up.)

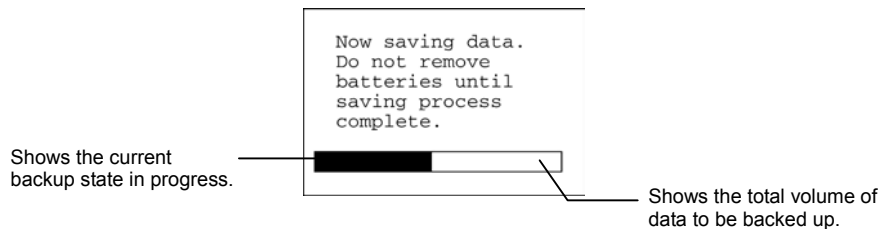

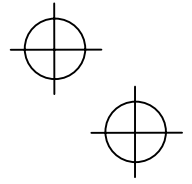
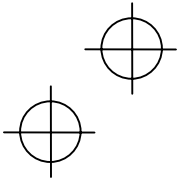

(2) When turning the BHT on after storage with no battery cartridge loaded:

Even after removal of the battery cartridge, the calendar clock will work with the backup power source for a while.

If the calendar clock backup has stopped, loading the battery cartridge and turning the BHT on will display the following message, prompting you to set the current date and time.

For details about the setting procedure, contact your system administrator.

(The indication "00/01/01 00:00" will vary depending upon the calendar clock state.)

```
Set the current
date and time.

00/01/01 00:00
_ / /   :
```

BHT Turning-off Notes

When the BHT is turned off by pressing the **PW** key or by the auto power-off feature, it displays the following message and starts preparation for shutdown.

```
Shutdown
in progress.

Do not remove the
battery.
```

When the above message is displayed, do not remove the battery cartridge.

If you do so and leave the BHT without the battery cartridge loaded for three minutes or more, then the error message "Contact your administrator. Note the error number. (2XXX)" may appear when turning the BHT on at the next time.

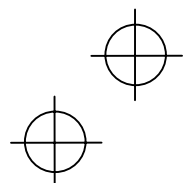
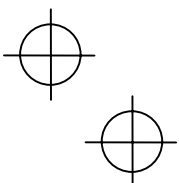

Error Messages

If some error occurs when the power is turned on or during program execution, one of the following error messages will appear on the LCD.

```
*****  
** No System! **  
*****
```

■ Problem

A System Program error has occurred.

NOTE

If this error occurs, the BHT beeps five times (for 0.1 second per beep) and then turns itself off.

■ Solution

Contact your system administrator.

Low battery warning

```
Battery voltage  
has lowered.
```

■ Problem

When the BHT is turned on or off or during execution of program, the battery output level has dropped below a specified lower limit.

NOTE

If low battery is detected, the BHT displays this message for approx. 2 seconds and beeps three times (for 0.1 second per beep). After that, it will resume previous regular operation.

■ Solution

The battery cartridge will need to be recharged before long.

Replace or recharge the battery cartridge.

```
Charge the
battery!
```

Shutdown due to low battery

■ Problem

When the BHT is turned on or during execution of programs, the battery output level has lowered so that the BHT no longer operates.

NOTE If lower battery is detected, the BHT beeps five times (for 0.1 second per beep) and then turns itself off. Depending upon the battery level, the beeper may not sound five times.

■ Solution

Replace or recharge the battery cartridge.

```
Set the current
date and time.
```

```
00/01/01 00:00
_ / /   :
```

Calendar clock stopped

■ Problem

The calendar clock integrated in the BHT has stopped because:

- the battery cartridge had been removed for a long time,
- the battery cartridge had not been recharged for a long time.

NOTE The indication of 00/01/01 00:00 will change depending upon the calendar clock state.

■ Solution

Contact your system administrator.

```
Your terminal was
not shut down
properly the last
time it was used.
```

```
[SF+2]
```

```
Unsaved data
was lost.
```

```
[SF+2]
```

Abnormal shutdown

■ Problem

After shut down abnormally*, the BHT has been left without the battery cartridge loaded, or with discharged battery cartridge loaded, so unsaved data was lost.

(*"Normally shut down" refers to turned-off with the PW key or by the auto power-off feature.)

■ Solution

Contact your system administrator.

```
Reload the battery
to restart!
```

```
XXXXXXXX 01
```

■ Problem

During execution of System Program, the System Program has attempted to write onto the write-protected area of the memory.

(xxxxxxx: Error address)

NOTE If this error occurs, the BHT beeps five times (for 0.1 second per beep).

■ Solution

Unload and reload the battery cartridge, then turn the BHT on. If this error occurs frequently, make a note of the displayed message and codes and contact your system administrator.

```
Reload the battery
to restart!
```

```
tskid:XXXXXXXX
ercd :XXXXXXXX
addr :XXXXXXXX 02
```

■ Problem

During execution of System Program, the System Program has received an invalid command code.

(xxxxxxx: Error address)

NOTE If this error occurs, the BHT beeps five times (for 0.1 second per beep).

■ Solution

Unload and reload the battery cartridge, then turn the BHT on. If this error occurs frequently, make a note of the displayed message and codes and contact your system administrator.

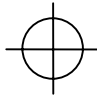
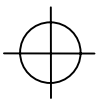

```
No user programs
      found.
Run code scanning
      demo?

1:Yes 2:No
```

No user programs found

■ Problem

When the BHT is turned on, no user programs are found.

■ Solution

You can run the code scanning demo without user programs.

Pressing "1:Yes" runs the code scanning demo. Press the trigger switch to start the code scanning demo. Selecting "2:No" turns the power off.

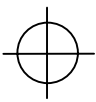
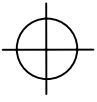

```
Contact your
      administrator.
Note the error
      number.
(XXXX)
```

System administrator to be called

■ Problem



Any of the hardware error, memory error and execution program error has occurred.

(xxxx: Error code)

NOTE If any of the above errors occurs, the BHT beeps five times (for 0.1 second per beep) and then turns itself off.

■ Solution

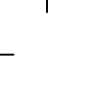
Turn the BHT on again. If this error occurs frequently, make a note of the displayed code and contact your system administrator.

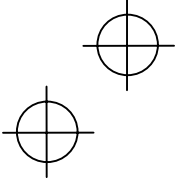
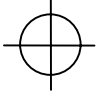

```
No resume info.
has been retained.
Program restarts
automatically.
```

Resume data lost

■ Problem

Although the resume function had been set to ON, no resume data has been retained since the BHT was not normally turned off and then left without the battery cartridge loaded or with the discharged battery cartridge loaded.

NOTE The BHT displays this error message for three seconds and automatically runs the execution program from the point of start-up.

```
Your settings in
System Mode
have been lost.

Will reset
to defaults.
```

Error in System Mode settings

■ Problem

Your settings made in System Mode contain an error.

NOTE If this error occurs, the System Mode settings revert to the factory defaults.

NOTE After displaying this error message for three seconds, the BHT may start a user program other than the preset auto-start execution program or display the message "No execution program loaded. Contact your administrator." If this error occurs, be sure to contact your system administrator.

■ Solution

Contact your system administrator.

System down error

■ Problem

An error has occurred during execution of System Program.

NOTE If this error occurs, the BHT beeps five times (for 0.1 second per beep).

```
Reload the battery
to restart!

E:xxxxxxxx-F:xxxxxxxx
1:xxxxxxxx-2:xxxxxxxx
P:xxxxxxxx-R:xxxxxxxx
```

■ Solution

Unload and reload the battery cartridge, then turn the BHT on.

If this error occurs frequently, contact your system administrator.

Proper Care of the BHT

Wipe the BHT's charge terminals and battery cartridge terminals with a cotton swab or the like periodically. Clean the BHT housing with a dry, soft cloth. Before cleaning, be sure to turn the BHT off.

- Never use benzene, alcohol, or other organic solvents. The housing may be marred or the paint may come off.
- Never rub or strike the liquid crystal display (LCD) with anything hard. The LCD surface will be easily scratched or broken.
- When cleaning the keypad, do not scrub the surface too hard or pull on the keys. Doing so may break the keys.
- If the BHT becomes smudged, wipe it with a soft cloth that has been moistened in soapy water (always use neutral detergent) and wrung out thoroughly.



Dust or dirt accumulating on the clear plate of the reading window will affect reading performance. If you use the BHT in dusty areas, therefore, periodically check the clear plate of the reading window and clean it if dusty.

- To clean the plate, first blow the dust away with an air brush. Then wipe the plate with a cotton swab or the similar soft one gently.
- If sand or hard particles have accumulated, never rub the plate; doing so will scratch or damage it. Blow the particles away with an airbrush or a soft brush.

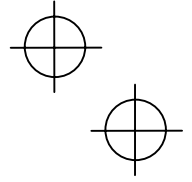
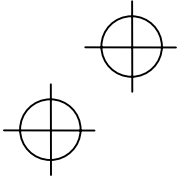

Handling Notes

- An early upload of gathered data is recommended, since the data stored in the RAM might be affected by the so-called "soft error" or other environmental phenomena. In some cases, the "Contact your administrator." will appear on the LCD.
- Do not use the BHT in the vicinity of radio equipment. The BHT may malfunction.
- Avoid storing the battery cartridge in a hot place. The battery capacity may be decreased.
- Do not touch the battery cartridge terminals or BHT's charge terminals by hand or stain them. Doing so could result in BHT's malfunction or cartridge charging failure.
- When connecting or disconnecting cables, do not plug or unplug at an angle and do not pull them strongly. Doing so will result in a machine failure.
- If the BHT has been stored in a hot (50°C to 60°C, 122°F to 140°F) and humid place, allow it to sit at room temperature and humidity for at least one day before use. Using the BHT with its inside being hot will fail to scan or result in a machine failure.
- In environments where static electricity can build into significant charges, do not operate the BHT. Doing so will result in malfunction or machine failure.
- Avoid dropping the BHT or letting it undergo any shock or impact. Doing so will break or damage the BHT.
- Battery cartridges should be recycled properly in conformity with local codes and regulations.

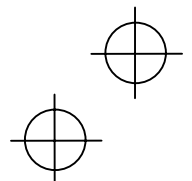
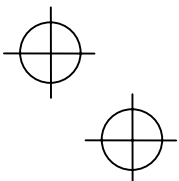

US and Canada Regulations

This device complies with Part 15 of FCC rules, Canada ICES-003 and RSS-210 Rules.

Operation is subject to the following two conditions:

- (1) this device may not cause harmful interference, and
- (2) this device must accept any interference received, including interference that may cause undesired operation.

NOTE : This equipment has been tested and found to comply with the limits for a Class A digital device, pursuant to Part 15 of the FCC Rules. These limits are designed to provide reasonable protection against harmful interference when the equipment is operated in a commercial environment. This equipment generates, uses, and can radiate radio frequency energy and, if not installed and used in accordance with the instruction manual, may cause harmful interference to radio communications. Operation of this equipment in a residential area is likely to cause harmful interference in which case the user will be required to correct the interference at his own expense.

NOTE : This Class A digital device apparatus complies with Canadian ICES-003.

Cet appareil numérique de la classe A est conforme à la norme NMB-003 du Canada.

FCC WARNING : Changes or modifications not expressly approved by the party responsible for compliance could void the user's authority to operate the equipment.

CAUTION : Radio Frequency Radiation Exposure

The available scientific evidence does not show that any health problems are associated with using low power wireless devices. There is no proof, however, that these low power wireless devices are absolutely safe. Low power Wireless devices emit low levels of radio frequency energy (RF) in the microwave range while being used. Whereas high levels of RF can produce health effects (by heating tissue), exposure to low-level RF that does not produce heating effects causes no known adverse health effects. Many studies of low-level RF exposures have not found any biological effects. Some studies have suggested that some biological effects might occur, but such findings have not been confirmed by additional research. This Handy Terminal (BHT-300BWB) has been tested and found to comply with FCC radiation exposure limits set forth for uncontrolled equipment and meets the FCC radio frequency (RF) Exposure Guidelines in Supplement C to OET65. The SAR evaluation has been performed all positions including the simultaneous transmission of Wireless LAN Adapter and Bluetooth Board that are contained in this Handy Terminal (BHT-300BWB). The maximum SAR level has been shown to be 0.094W/kg at Body.

Co-location : This Handy Terminal (BHT-300BWB) must not be co-located or operated in conjunction with any other antenna or transmitter.

Labeling

Rating plate

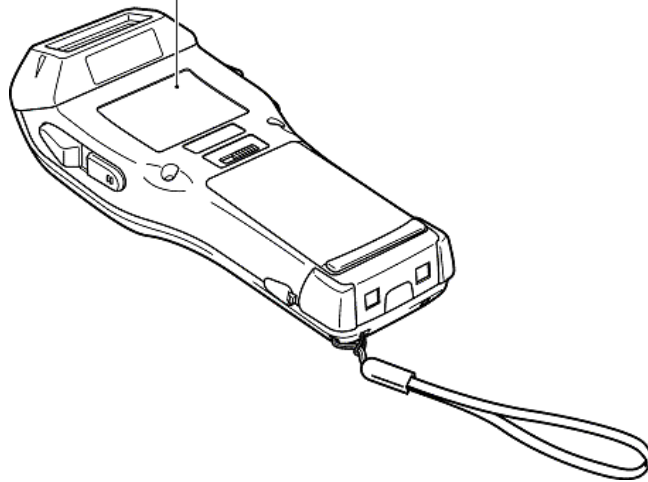

Customer Registration Form

Thank you for purchasing our product. We would like to offer you the following support and assistance for your more convenient use of our products when you fill out and submit the customer registration form.

Privileges of customer registration

1. Free upgrade information
2. Free exhibition and event information of new products
3. Free web-information service "QBnet."

"QBnet" Contents

- Information searching
- Download service
- Inquiry with email

※These are subject to change without notice.

How to Register

Through Internet at the following address

<http://www.denso-wave.com/en/adcd/support/>

After going into Internet, please access the above-mentioned URL address.

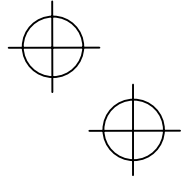
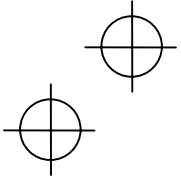

DENSO WAVE INCORPORATED

4-2-12, Toranomom, Minato-ku, Tokyo, Japan 105-0001

<http://www.denso-wave.com/>

496996-0330

