

DENSO

RF TAG Handy Reader Writer

SE1-HU

This Instruction Manual sets forth the procedures for handling and precautions. Before use, read through this guide carefully to make sure that you use the antenna controller both correctly and effectively. Also keep it handy for ready reference. For more details on using this antenna controller, see the User's Manual that is available as a free download from our website 'QBdirect' at '<http://www.qbdirect.net/>'. Before downloading, you are requested to register as a member (free of charge).



DENSO WAVE INCORPORATED

Copyright © 2012 DENSO WAVE INCORPORATED. All rights reserved.

466144-XXXX

■ About This Manual

- Specifications are subject to change without prior notice.
- No part of this publication may be reproduced in any form or by any means without permission in writing from the publisher.
- Please contact DENSO WAVE if you lose this document.
- DENSO WAVE has taken all possible means to ensure this document. Please inform us if you have any doubt or find mistakes or missing in the contents of this document.

■ Liability Limitations

- DENSO WAVE takes reasonable precautions to ensure its products do not infringe upon any patent or other intellectual property rights of other(s), but DENSO WAVE cannot be responsible for any patent or other intellectual property right infringement(s) or violation(s) which arise from any of the following:
 - (i) The use of DENSO WAVE's product(s) in connection or in combination with other component(s), product(s), data processing system(s) or equipment or software not supplied from DENSO WAVE;
 - (ii) The use of DENSO WAVE's products in a manner for which the same were not intended nor designed; or
 - (iii) The modification of DENSO WAVE's products by other(s) than DENSO WAVE.
- Any malfunctions which DENSO WAVE considers to be caused by having been dropped or received excessive shock shall be repaired at the user's own expense even within the warranty period.
- DENSO WAVE takes no responsibility for the operation of ID systems implemented in the applications where high security level is required or applications that may have a direct or indirect affect on human body including:
 - (i) Applications where outdoor use or interference on electrical and electronic devices is expected.
 - (ii) Air carriers, hospitals, railways, safety control facilities related to nuclear power, public administrations, regulations for controlling entertainment and individual institutions, human life, security control organizations for assets and around-the-clock control facilities to maintain essential utilities such as electricity, water and gas supplies.

DENSO WAVE INCORPORATED

1 Yoshiike Kusagi Agui-cho, Chita-gun Aichi 470-2297, Japan
<http://www.denso-wave.com/>

DECLARATION OF CONFORMITY

For European Union

[EN] English	Hereby, DENSO WAVE INCORPORATED declares that this HIGH FREQUENCY 13.56MHz TRANSCEIVER is in compliance with the essential requirements and other relevant provisions of Directive 1999/5/EC.
[BG] Bulgarian	С настоящето, DENSO WAVE INCORPORATED, декларира, че HIGH FREQUENCY 13.56MHz TRANSCEIVER е в съответствие със съществените изисквания и другите приложими разпоредби на Директива 1999/5/EC.
[HR] Croatian	Ovim DENSO WAVE INCORPORATED, izjavljuje da je HIGH FREQUENCY 13.56MHz TRANSCEIVER u skladu s bitnim zahtjevima i drugim relevantnim odredbama Direktive 1999/5/EC i Pravilnika o RiTT opremi (NN25/2012).
[CS] Czech	DENSO WAVE INCORPORATED tímto prohlašuje, že HIGH FREQUENCY 13.56MHz TRANSCEIVER splňuje základní požadavky a všechna příslušná ustanovení Směrnice 1999/5/ES.
[DA] Danish	Undertegnede DENSO WAVE INCORPORATED erklærer herved, at følgende udstyr HIGH FREQUENCY 13.56MHz TRANSCEIVER overholder de væsentlige krav og øvrige relevante krav i direktiv 1999/5/EF.
[DE] German	Hiermit erkläre DENSO WAVE INCORPORATED, dass sich das Gerät HIGH FREQUENCY 13.56MHz TRANSCEIVER in Übereinstimmung mit den grundlegenden Anforderungen und den übrigen einschlägigen Bestimmungen der Richtlinie 1999/5/EG befindet.
[ET] Estonian	Käesolevaga kinnitab DENSO WAVE INCORPORATED seadme HIGH FREQUENCY 13.56MHz TRANSCEIVER vastavust direktiivi 1999/5/EÜ põhinõuetele ja nimetatud direktiivist tulenevatele teistele asjakohastele sätetele.
[EL] Greek	ΜΕ ΤΗΝ ΠΑΡΟΥΣΑ Ο ΚΑΤΑΣΚΕΥΑΣΤΗΣ DENSO WAVE INCORPORATED ΔΗΛΩΝΕΙ ΟΤΙ HIGH FREQUENCY 13.56MHz TRANSCEIVER ΣΥΜΜΟΡΦΩΝΕΤΑΙ ΠΡΟΣ ΤΙΣ ΟΥΣΙΩΔΕΙΣ ΑΠΑΙΤΗΣΕΙΣ ΚΑΙ ΤΙΣ ΛΟΙΠΕΣ ΣΧΕΤΙΚΕΣ ΔΙΑΤΑΞΕΙΣ ΤΗΣ ΟΔΗΓΙΑΣ 1999/5/ΕΚ
[ES] Spanish	Por la presente, DENSO WAVE INCORPORATED, declara que este HIGH FREQUENCY 13.56MHz TRANSCEIVER cumple con los requisitos esenciales y otras exigencias relevantes de la Directiva 1999/5/EC.
[FR] French	Par la présente, DENSO WAVE INCORPORATED déclare que l'appareil HIGH FREQUENCY 13.56MHz TRANSCEIVER est conforme aux exigences essentielles et aux autres dispositions pertinentes de la directive 1999/5/CE.
[IT] Italian	Con la presente DENSO WAVE INCORPORATED dichiara che questo HIGH FREQUENCY 13.56MHz TRANSCEIVER è conforme ai requisiti essenziali ed alle altre disposizioni pertinenti stabilite dalla direttiva 1999/5/CE.
[LV] Latvian	Ar šo DENSO WAVE INCORPORATED deklarē, ka HIGH FREQUENCY 13.56MHz TRANSCEIVER atbilst Direktīvas 1999/5/EK būtiskajām prasībām un citiem ar to saistītajiem noteikumiem.
[LT] Lithuanian	Šiuo DENSO WAVE INCORPORATED deklaruoja, kad šis HIGH FREQUENCY 13.56MHz TRANSCEIVER atitinka esminius reikalavimus ir kitas 1999/5/EB Direktyvos nuostatas

[HU] Hungarian	A DENSO WAVE INCORPORATED ezzennel kijelenti, hogy a HIGH FREQUENCY 13.56MHz TRANSCEIVER típusú berendezés teljesíti az alapvető követelményeket és más 1999/5/EK irányelvben meghatározott vonatkozó rendelkezéseket.
[NL] Dutch	Hierbij verklaart DENSO WAVE INCORPORATED dat het toestel HIGH FREQUENCY 13.56MHz TRANSCEIVER in overeenstemming is met de essentiële eisen en de andere relevante bepalingen van richtlijn 1999/5/EG.
[PL] Polish	Niniejszym DENSO WAVE INCORPORATED deklaruje że HIGH FREQUENCY 13.56MHz TRANSCEIVER jest zgodny z zasadniczymi wymaganiami i innymi właściwymi postanowieniami Dyrektywy 1999/5/EC.
[PT] Portuguese	Eu, DENSO WAVE INCORPORATED, declaro que o HIGH FREQUENCY 13.56MHz TRANSCEIVER cumpre os requisitos essenciais e outras provisões relevantes da Directiva 1999/5/EC.
[RO] Romanian	Prin prezenta, DENSO WAVE INCORPORATED, declară că aparatul HIGH FREQUENCY 13.56MHz TRANSCEIVER este în conformitate cu cerințele esențiale și cu alte prevederi pertinente ale Directivei 1999/5/CE.
[SK] Slovak	DENSO WAVE INCORPORATED týmto vyhlasuje, že HIGH FREQUENCY 13.56MHz TRANSCEIVER spĺňa základné požiadavky a všetky príslušné ustanovenia Smernice 1999/5/ES.
[SL] Slovenian	DENSO WAVE INCORPORATED izjavlja, da je ta HIGH FREQUENCY 13.56MHz TRANSCEIVER v skladu z bistvenimi zahtevami in drugimi relevantnimi določili direktive 1999/5/ES.
[FI] Finish	DENSO WAVE INCORPORATED vakuuttaa täten että HIGH FREQUENCY 13.56MHz TRANSCEIVER tyyppinen laite on direktiivin 1999/5/EY oleellisten vaatimusten ja sitä koskevien direktiivin muiden ehtojen mukainen.
[SV] Swedish	Denna utrustning är i överensstämmelse med de väsentliga kraven och andra relevanta bestämmelser i direktiv 1999/5/EC.

■NOTICE

This High Frequency 13.56 MHz Transceiver may be operated in below country:

AT	CZ	FR	HR	LT	PL	SI	IS	HR
BE	DK	DE	IE	LU	PT	ES	LI	MK
BG	EE	GR	IT	MT	RO	SE	NO	TR
CY	FI	HU	LV	NL	SK	GB	CH	LI

Manufacture

Name: DENSO WAVE INCORPORATED
Address: 1, Yoshiike, Kusagi, Agui-cho, Chita-gun, Aichi, 470-2297, Japan

Product: RF TAG Handy Reader Writer

Model/ Type Number: SE1-HU

CE marking



■ NOTICE

This device complies with Part 15 of FCC Rules and Industry Canada licence-exempt RSS standard(s). Operation is subject to the following two conditions:

- (1) this device may not cause interference.
- (2) this device must accept any interference, including interference that may cause undesired operation of this device.

Le présent appareil est conforme à la partie 15 des règles de la FCC et CNR d'Industrie Canada applicables aux appareils radio exempts de licence. L'exploitation est autorisée aux deux conditions suivantes :

- (1) l'appareil ne doit pas produire de brouillage.
- (2) l'utilisateur de l'appareil doit accepter tout brouillage radioélectrique subi, même si le brouillage est susceptible d'en compromettre le fonctionnement.

This equipment has been tested and found to comply with the limits for a Class A digital device, pursuant to part 15 of the FCC Rules. These limits are designed to provide reasonable protection against harmful interference when the equipment is operated in a commercial environment. This equipment generates, uses, and can radiate radio frequency energy and, if not installed and used in accordance with the instruction manual, may cause harmful interference to radio communications. Operation of this equipment in a residential area is likely to cause harmful interference in which case the user will be required to correct the interference at his own expense.

This Class A digital apparatus complies with Canadian ICES-003.
Cet appareil numérique de la classe A est conforme à la norme NMB-003 du Canada.

■ FCC WARNING

Changes or modifications not expressly approved by the party responsible for compliance could void the user's authority to operate the equipment. Properly shielded and grounded cables and connectors must be used for connection to host computers and / or peripherals in order to meet FCC emission limits.

■ FCC Radiation Exposure Statement

This transmitter must not be co-located or operated in conjunction with any other antenna or transmitter.

■ 中国SRRC

1. 本产品的使用方法等请参见产品说明书。本产品的技术参数如下：
 - 使用频率为：13.553-13.567MHz
 - 所发射的电场强度在距设备10米处不得超过42dB μ A/m(采用准峰值检波)；
 - 频率容限： $\leq 100 \times 10^{-6}$
 - 杂散辐射：对于13.553-13.567MHz频段设备，频段两端偏移140kHz频率范围的限值为9dB μ A/m(10米处，准峰值)
 - 杂散辐射等其他技术指标请参照2005/423号文件
2. 使用者不得擅自更改发射频率、加大发射功率(包括额外加装射频功率放大器)，不得擅自外接天线或改用其它发射天线；
3. 使用时应注意不得对各种合法的无线电通信业务产生有害干扰；一旦发现有干扰现象时，应立即停止使用，并采取消除措施后方可继续使用；
4. 本产品为微功率无线电设备，能够承受各种无线电业务的干扰或工业、科学及医疗应用设备的辐射干扰；
5. 本产品不得在飞机和机场附近使用。

■ 日本電波法

本機は日本国電波法で定められた「誘導式読書き通信設備」に該当します。
各機器は以下の技術基準に適合し、総務省指定の型式指定を受けています。

適合規格: ARIB STD-T82
総務省型式指定番号: 第AC-XXXXXX号



SAFETY PRECAUTIONS

Be sure to observe all these safety precautions.



- Please READ through these instructions carefully. They will enable you to use the scanner correctly.
- Always keep this manual nearby for speedy reference.

Strict observance of these warnings and cautions is a MUST for preventing accidents that could result in bodily injury and substantial property damage. Make sure you fully understand all definitions of these terms and symbols given below before you proceed to the text itself.

WARNING

 WARNING	Alerts you to those conditions that could cause serious bodily injury or death if the instructions are not followed correctly.
 CAUTION	Alerts you to those conditions that could cause minor bodily injury or substantial property damage if the instructions are not followed correctly.

SYMBOLS

	A triangle (Δ) with a picture inside alerts you to a warning of danger. Here you see the warning for electrical shock.
	A diagonal line through a circle (⊘) warns you of something you should not do; it may or may not have a picture inside. Here you see a screwdriver inside the circle, meaning that you should not disassemble.
	A black circle (\bullet) with a picture inside alerts you to something you MUST do.

WARNING

Wrong handling of the product against these warning precautions could result in serious bodily injury or death. It may lead to electric shock, vision disturbance, impaired skin, injury or burn or will cause the product to generate heat or smoke. Be sure to observe the following when using this product.

Effect on implantable medical device

	<p>This product is a reader/writer of RFID devices using electric waves. Medical device may be affected by RFID device in some applications/places. Observe the following precautions to reduce the effect for implementing RFID.</p> <p>Those wearing an active implantable medical device (AIMD) are required to stay at least 22 cm away from the antenna part of a fixed or module type RFID device.</p> <p>Several current reports indicate that RFID devices may cause malfunctions in AIMDs such as implantable cardiac pacemakers, implantable cardioverter-defibrillator. This is attributed to general characteristics of electric or electronic devices using radio waves, and not the unique features of DENSO WAVE's products or this product itself.</p>
---	--

To System Designers

⊘	When introducing the product in those systems that affect human lives, develop applications carefully through redundancy and safety design which avoids the feasibility of affecting human lives even if a data error occurs.
---	---

Installation

⊘	Do not use the product in places where use of radio waves is restricted, such as on airplanes or in hospitals. Doing so could cause malfunction in electronic devices or medical equipment.
⊘	Never charge the product where any inflammable, explosive or corrosive gases may be emitted. Doing so could cause fire.
⊘	Do not use the product in places where water, oil, or chemicals are nearby or where there are grit and dust, salt content or metallic powder. Doing so could cause the product to break or burn.
⊘	Do not use product in places where strong vibration or shock is applied. Doing so could cause the product to break or fire.

Handling

⊘	Do not use the product when exceeding the temperature and humidity specified in the specification. Doing so could cause the product to break or burn.
!	If smoke, abnormal odors or noises comes from the product, immediately switch off the product. Failure to do so could cause fire or electrical shock.
⊘	Do not scratch, modify, bend, twist, pull, or heat the cable, or allow the cable to get pressed under heavy materials. The power cable severely handled shall be replaced with a new one. Failure to do so could cause fire or electrical shock.
!	If the cable has a lock mechanism, be sure to lock the cable before using it. Failure to do so could cause fire or electrical shock.
!	Always fix the power cable with a clamp. Putting strong pressure could break the cable, resulting fire, electric shock.
!	If foreign material or water gets into the product, immediately remove the cable. Failure to do so could cause fire or electrical shock.
⊘	Never bring any metals into contact with the electronic parts, touch them with hands or apply electric potential. Failure to do so could cause fire or electrical shock.
!	Be sure to tightly fix the screws. The product may be broken, resulting in fire or electrical shock if any of the screws is loose.
⊘	Do not use the device when they are not operated or broken after dropping the device. Failure to do so could cause fire or electrical shock.
⊘	Never put the product into a microwave oven or high-pressure container.
!	All these warnings and precautions must be strictly observed when using the product.

⚠ CAUTION

Operating environments and Installation

⊘	Never put the product in places where there are excessively high temperatures, such as inside closed-up automobiles, in places exposed to direct sunlight, or in places generating heat accumulation caused by radiant, etc. Doing so could affect the parts, resulting in a fire.
⊘	Avoid using the product in extremely humid, dusty areas or, where there are drastic temperature changes. Moisture or dust will get into the product, resulting in malfunction, fire, or electrical shock.
⚠	This product uses the 13.56MHz frequency band to communicate with Tags. Some devices, such as some motors, inverters, generate electromagnetic waves (i.e., noise) that can affect communications with Tags. If any of these devices are nearby, communications with Tags may be affected, resulting in malfunction. If the product is to be used near such devices, check the effects on communications before using the product.
⊘	Avoid wiring nearby power line of high voltage or high current. Doing so could affect communications, resulting in malfunction.
⚠	Ground the earth terminal of this product and any metallic material located around the product to 100Ω or less.
⊘	Do not use the product nearby a radio set such as personal radio or amateur radio. Doing so could cause malfunction.
⚠	Communications performance may be reduced, resulting in malfunction due to mutual interference if there is more than one Read/Write Antenna. Refer to the manual and confirm that there is no mutual interference between Read/Write Antennas.

Handling

⚠	Never disassemble or modify the product, doing so could result in fire or electric shock.
⊘	Do not apply static electricity to electrical parts or connector when installing or wiring the device. Doing so could cause fire or electrical shock.
⚠	Hot plugging/unplugging is not allowed for the connector. Doing so could result in electrical shock, malfunction, or failure.
⊘	Do not plug the unspecified connector into the product. Doing so could cause fire or electrical shock.
⊘	Do not use the screws except specified ones. Doing so could result in electrical shock, fire, malfunction, or failure.
⊘	Keep magnetic cards such as a cash card or a credit card away from this product. Failure to do so could cause loss of magnetic data.
⚠	For safety reasons, disconnect the connection cable when the product is not in use for long periods of time. Do not use thinners for cleaning. For the safety reasons, unplug the connection cable during the maintenance. Failure to do so could cause electrical shock. Do not use thinners for cleaning. The plastic case coating will be dissolved by thinners.

Specification

Item	Specification	
Supply Voltage	5 V DC (From the USB connector of the host controller)	
Current Consumption	0.5 A (at 5 V DC)	
Oscillating Frequency	MAIN : 20 MHz (PLL : 120MHz) ,RF : 13.56 MHz	
Operating temperature range	-0 to 40°C (freezing not allowed)	
Operating humidity range	35% to 95%RH (condensation not allowed)	
Storage temperature range	-10 to 50°C (freezing not allowed)	
Storage humidity range	35% to 95%RH (condensation not allowed)	
Applied standard *	Japan	ARIB-STD-T82 AC-XXXXX
	Europe	R&TTE Directive Radio: EN302 291-1,-2 EMC: EN301 489-1,-3 Safety:EN 60950-1
	USA	FCC Part 15 Subpart C FCC ID: PZWSE1HU001
	Canada	RSS-Gen RSS-210 IC: 1551C-SE1HU001
	China	SRRC CMIIT ID: 2013xxXXXX
Environmental Conditions	Indoor use only	
	Altitude up to 2000 m	
Weight	200 g	

* if the equipment is used in a manner not specified by the manufacturer, the protection provided by the equipment may be impaired.

External dimensions

(Unit: mm [inch])

Weight: Approx. 150 g

Standard Tolerance	
Nominal Dimension (L)	Tolerance
$L \leq 18$ [0.71]	± 1.2 [0.047]
$18 < L \leq 30$ [1.18]	± 1.5 [0.059]
$30 < L \leq 50$ [1.97]	± 2.3 [0.091]
$50 < L \leq 80$ [3.15]	± 3.0 [0.118]
$80 < L \leq 120$ [4.73]	± 3.8 [0.150]
$120 < L \leq 180$ [7.09]	± 4.5 [0.177]
$180 < L \leq 250$ [9.85]	± 6.0 [0.236]

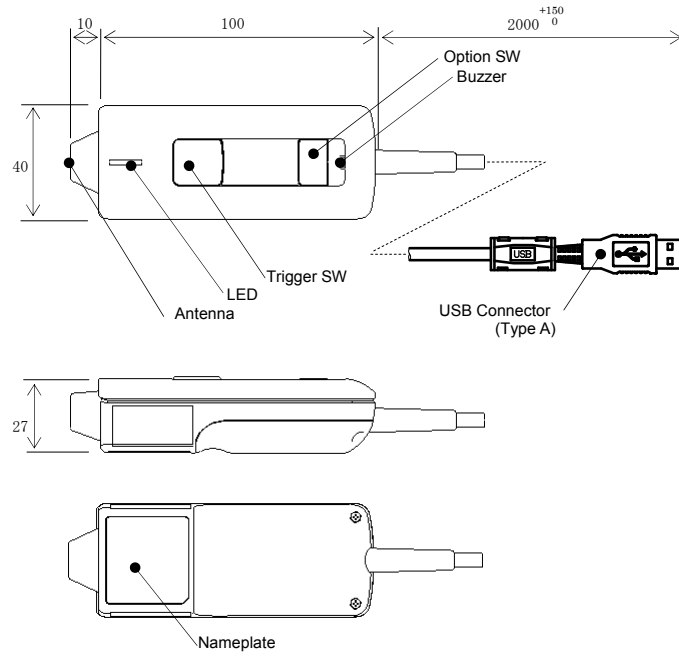

(Note)
Tolerances of dimensions for which tolerances are not indicated conform to the standard tolerance in the table above.