

DENSO

BHT-7500S

Bar Code Handy Terminal

Operator's Guide

This guide has been prepared expressly for the hands-on user. Always keep it nearby for speedy reference.

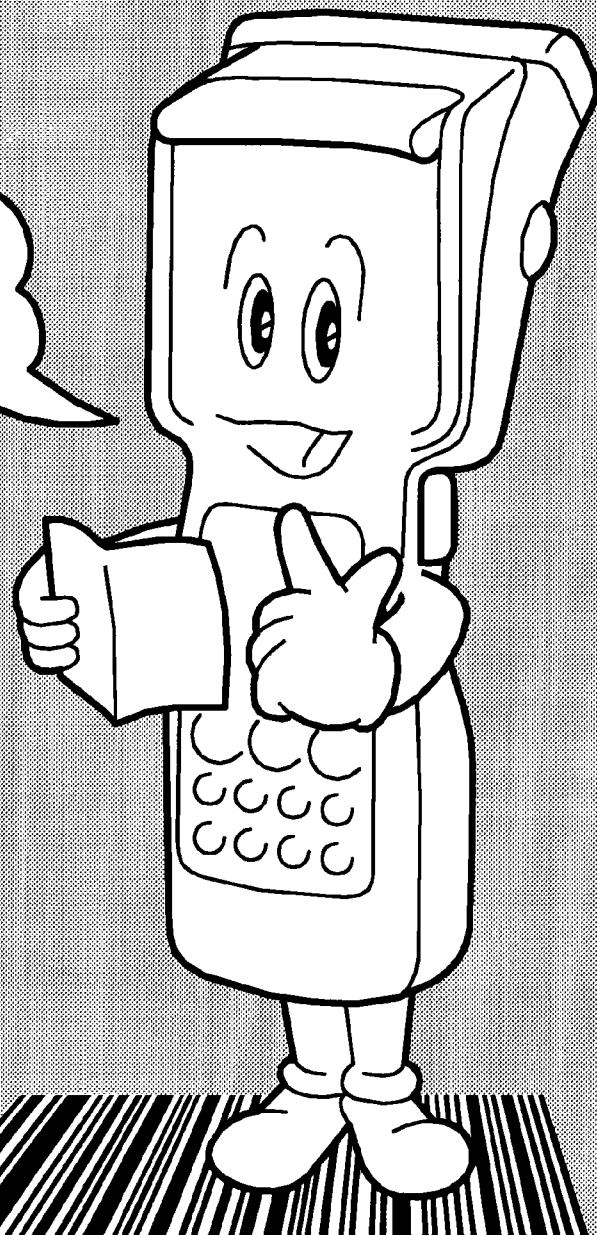

Related Publications

BHT-7500S User's Manual (sold separately)

Instructions for using the handy terminal (BHT-7500S) and optical communication unit (CU-7000).

BHT-BASIC Programmer's Manual (that comes with BHT-BASIC Compiler in CD-ROM)

Description for developing application programs of the handy terminal in BHT-BASIC.

Transfer Utility Guide (that comes with Transfer Utility)

Description about software that transmits data and programs between the handy terminal and computer.

Ir-Transfer Utility C Guide (that comes with Ir-Transfer Utility C)

Description about software that transmits data and programs between the handy terminal and computer via the optical communication unit (CU).

Ir-Transfer Utility E Guide (that comes with Ir-Transfer Utility E)

Description about software that transmits data and programs between the handy terminal and computer via the computer's integrated IR port or any of the specified external IR transceivers.

SAFETY PRECAUTIONS

Be sure to observe all these safety precautions.

Strict observance of these warning and caution indications are a **MUST** for preventing accidents which could result in bodily injury and substantial property damage. Make sure you fully understand all definitions of these terms and related symbols given below, before you proceed on to the text itself.

WARNING

Alerts you to those conditions which could cause serious bodily injury or death if the instructions are not followed correctly.

CAUTION

Alerts you to those conditions which could cause minor bodily injury or substantial property damage if the instructions are not followed correctly.

Meaning of Symbols



A triangle (\triangle) with a picture inside alerts you to a warning of danger. Here you see the warning for electrical shock.



A diagonal line through a circle (\otimes) alerts you to something you should not do; it may or may not have a picture inside. Here you see a screwdriver inside the circle, meaning that you should not disassemble.



A black circle (\bullet) with a picture inside alerts you to something you **MUST** do. This example shows that you **MUST** unplug the power cord.

WARNING

Handling the rechargeable battery cartridge

- Never disassemble or heat the rechargeable battery cartridge, nor put it into fire or water; doing so could cause battery-rupture or leakage of battery fluid, resulting in a fire or bodily injury.



! WARNING

- Do not carry or store the rechargeable battery cartridge together with metallic ball-point pens, necklaces, coins, hairpins, etc.

Doing so could short-circuit the terminal pins, causing the batteries to rupture or the battery fluid to leak, resulting in a fire or bodily injury.

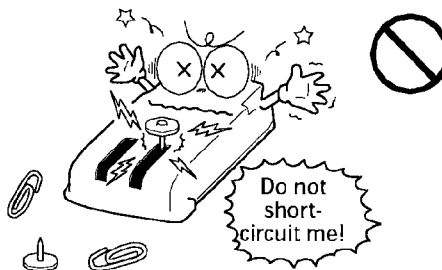

- Avoid dropping the rechargeable battery cartridge or letting it undergo any shock or impact.

Doing so could cause the batteries to break, generate heat, rupture or burn.



- Only use the dedicated charger (CU-7001, C-700 or C-750) for charging the battery cartridge.

Using a different type of charger could cause battery-rupture or leakage of battery fluid and result in a fire, bodily injury, or serious damage to property.

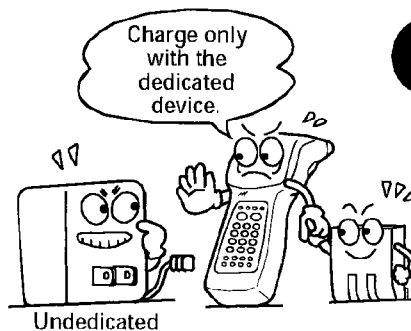

Undedicated

- Never charge the rechargeable battery cartridge where any inflammable gases may be emitted; doing so could cause fire.



Handling the BHT

- The BHT-7500S uses a laser light for scanning barcode. The intensity of the laser light might be too low to inflict bodily injury. However, do not look into the laser beam.

The BHT-7500S complies with Laser Safety Standard, Class II of 21 CFR Chapter 1, Subchapter J.

The BHT-7500S does not mount beam attenuator and laser radiation emission indicator required by this standard. Instead, the software-controlled Magic keys (see "Components and Functions") function as them because the laser light is not enabled without the Magic keys pressed.



CAUTION



LASER LIGHT-DO NOT STARE INTO BEAM

1mW MAXIMUM OUTPUT; 650nm LASER

CLASS II LASER PRODUCT

- Do not look into the laser beam through the reading window or point the laser beam towards the eyes.
The laser beam emitted through the reading window is harmful to the eyes.
- Use of controls or adjustments or performance of procedures other than those specified herein may result in hazardous radiation exposure.

⚠ CAUTION

Handling the rechargeable battery cartridge

- Never charge a wet or damp rechargeable battery cartridge.

Doing so could cause the batteries to break, generate heat, rupture or burn.



Handling the BHT

- Never put the BHT in places where there are excessively high temperatures, such as inside closed-up automobiles, or in places exposed to direct sunlight.

Doing so could affect the housing or parts, resulting in a fire.

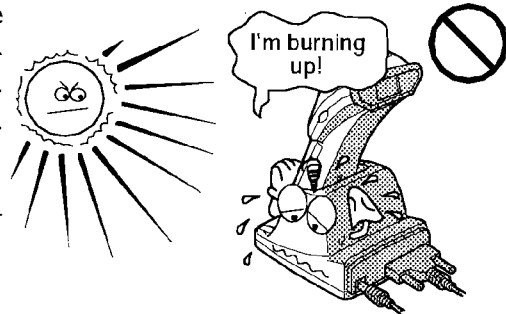

- Avoid using the BHT in extremely humid or dusty areas, or where there are drastic temperature changes.

Moisture or dust will get into the BHT, resulting in malfunction, fire or electrical shock.

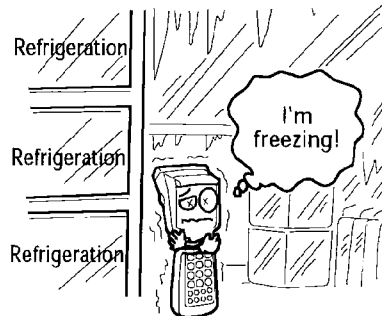
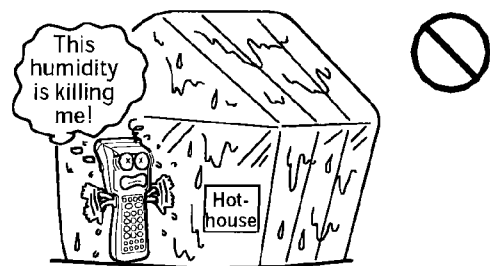

CAUTION

- Never disassemble or modify the BHT; doing so could result in an accident such as break or fire.



Never disassemble

- If smoke, abnormal odors or noises come from the BHT, immediately turn off the power, pull out the rechargeable battery cartridge, and contact your nearest dealer.



Failure to do so could cause smoke or fire.

- If foreign material or water gets into the BHT, immediately turn off the power, pull out the rechargeable battery cartridge, and contact your nearest dealer.

Failure to do so could cause smoke or fire.



- If you drop the BHT so as to damage its housing, immediately turn off the power, pull out the rechargeable battery cartridge, and contact your nearest dealer.

Failure to do so could cause smoke or fire.



- Do not use batteries or power sources other than the specified ones; doing so could generate heat or cause malfunction.



- In environments where static electricity can build into significant charges (e.g., if you wipe off the plastic plate with a dry cloth), do not operate the BHT. Doing so will result in malfunction or machine failure.



- DENSO CORPORATION does not assume any product liability arising out of, or in connection with, the application or use of any product, circuit, or application described herein.

- Intellectual Property Precaution

DENSO CORPORATION ("DENSO") takes reasonable precautions to ensure its products do not infringe upon any patent or other intellectual property rights of other(s), but DENSO cannot be responsible for any patent or other intellectual property right infringement(s) or violation(s) which arise from (i) the use of DENSO's product(s) in connection or in combination with other component(s), product(s), data processing system(s) or equipment or software not supplied from DENSO; (ii) the use of DENSO's products in a manner for which the same were not intended nor designed; or (iii) any modification of DENSO's products by other(s) than DENSO.

Components and Functions

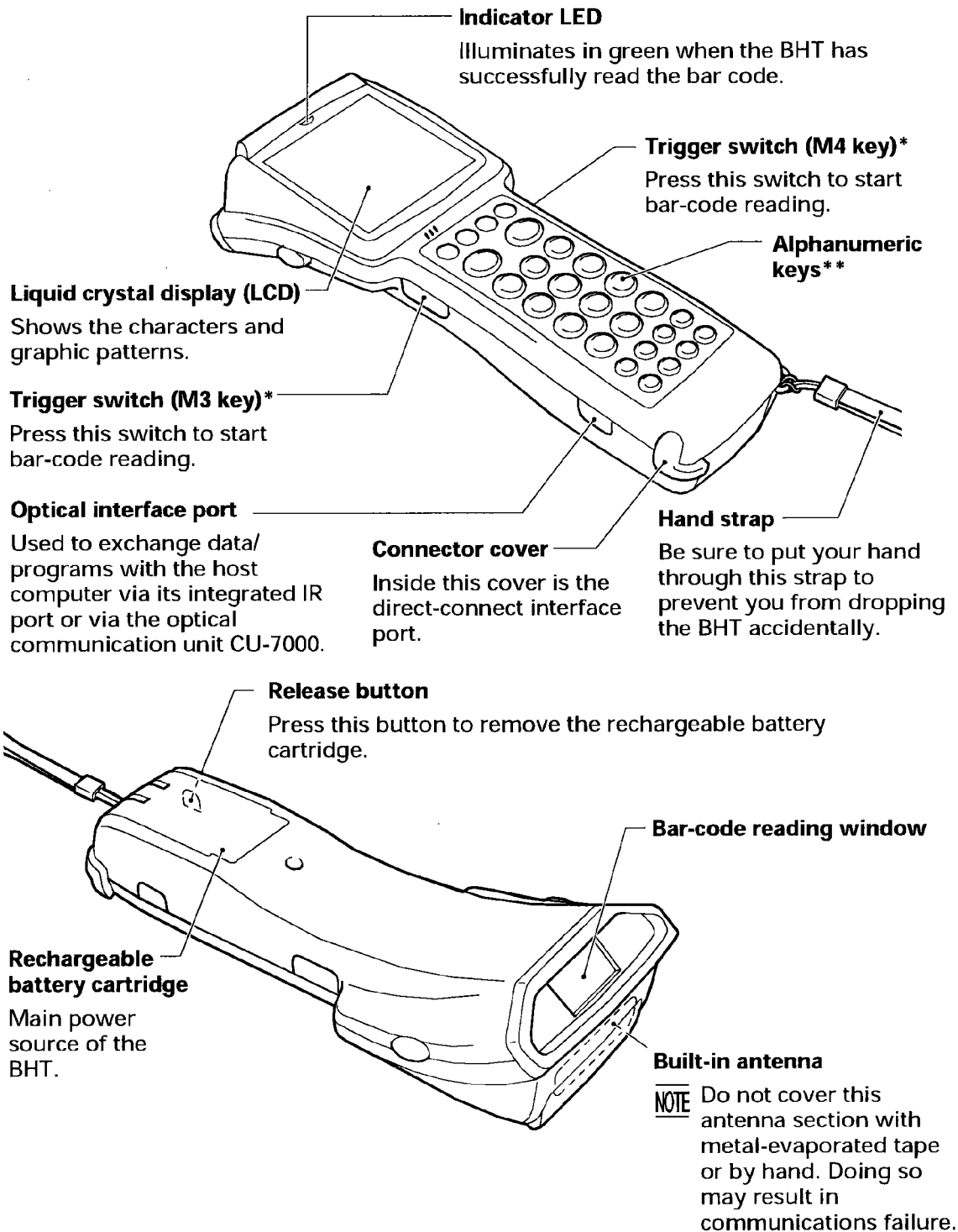

* The trigger switch function is assigned to both of the M3 and M4 keys by default.

** The keypad is available in two types: 32-key pad and 26-key pad.

The functions of the keys may be set by user programs. Shown below is a set of sample functions.

32-key pad

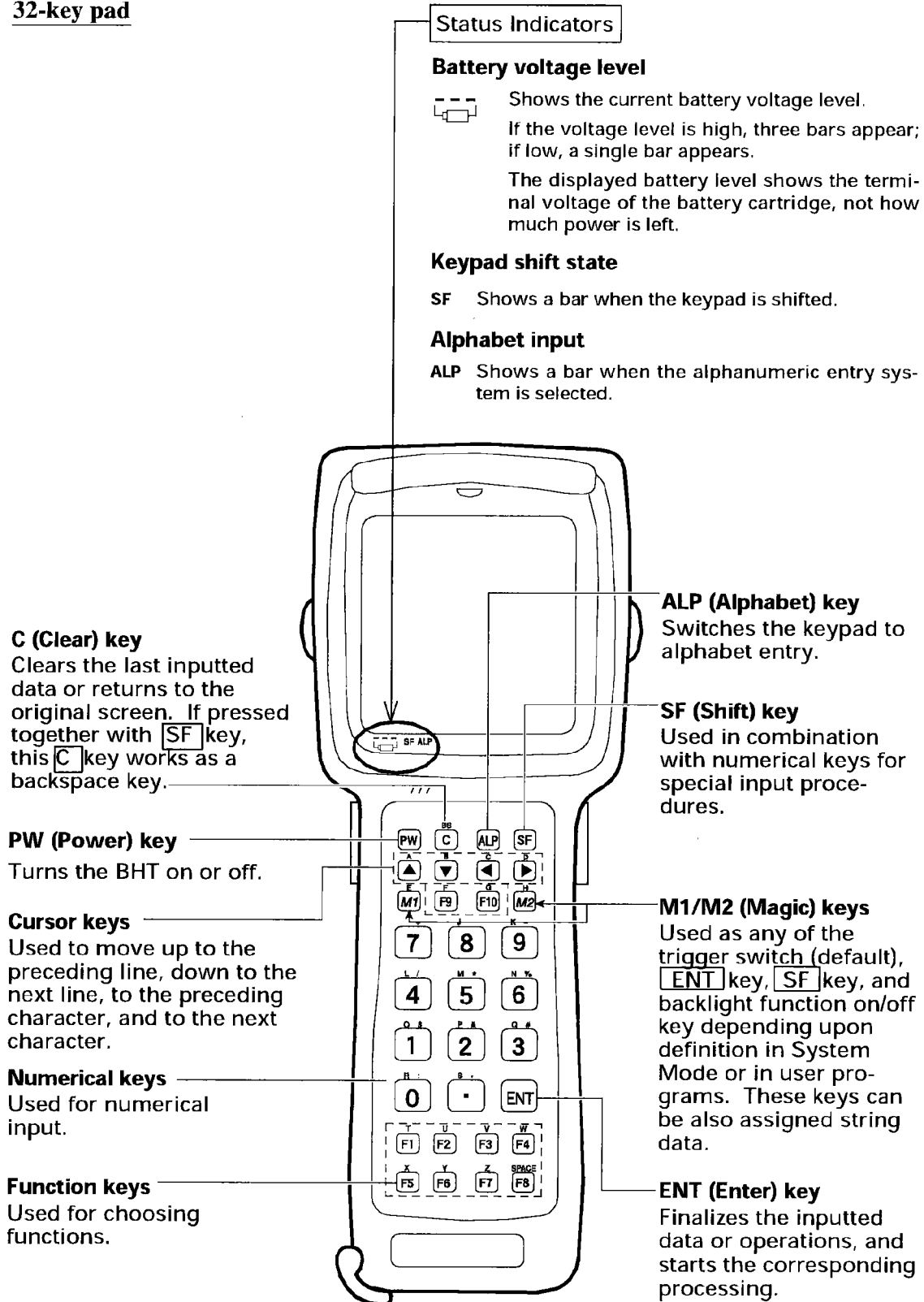

26-key pad

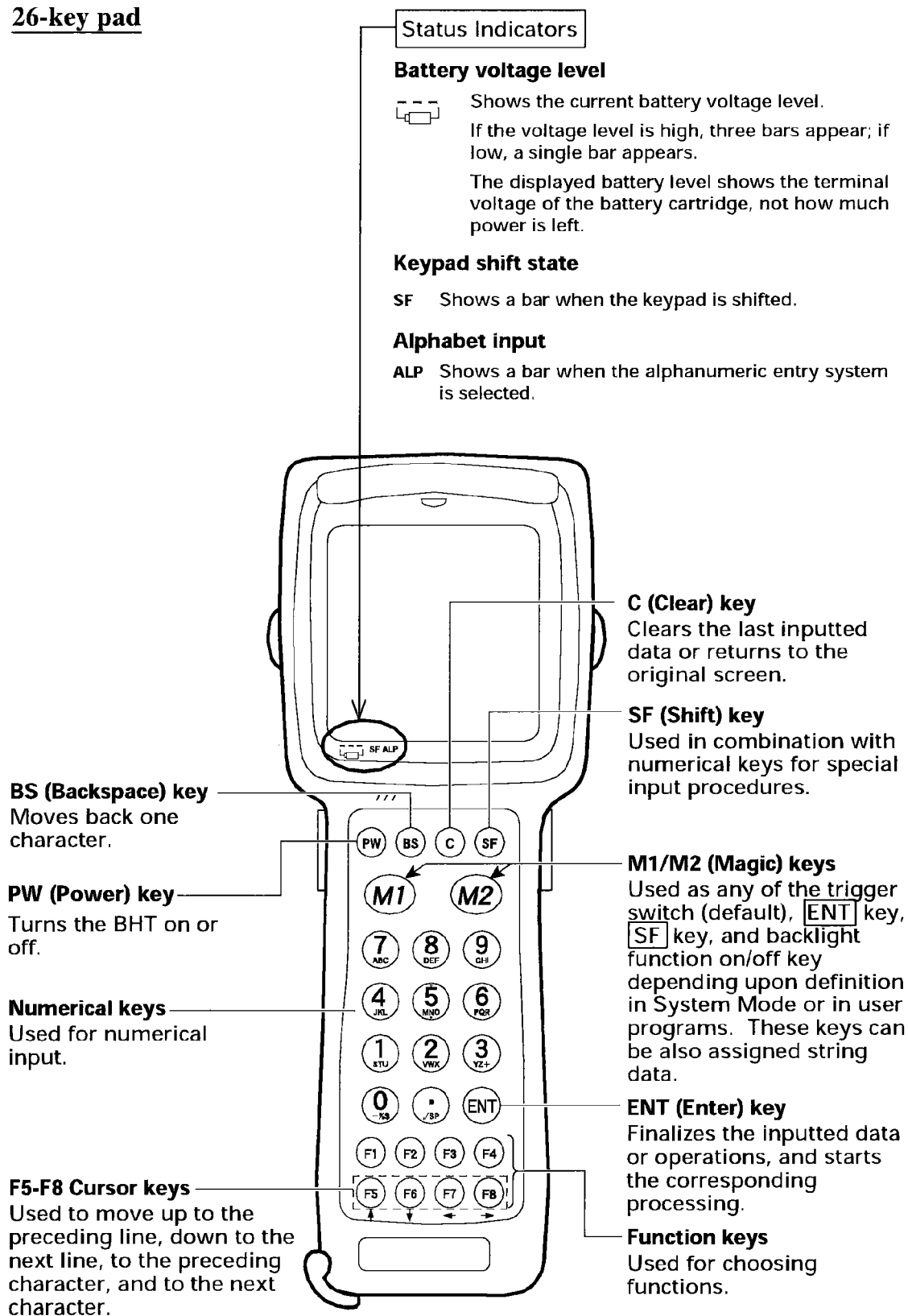

Reading Bar Codes

Turn on the BHT power, bring the bar-code reading window to the bar code to be scanned, and press the trigger switch. The BHT emits a laser light to scan the bar code.

When the BHT has read the bar code successfully, the indicator LED will illuminate in green.

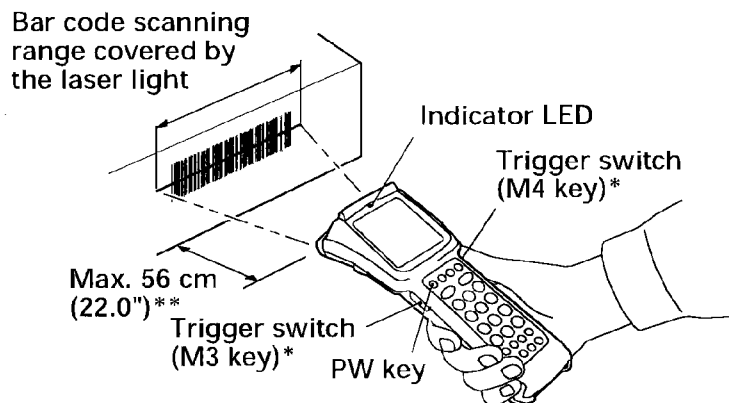

* The trigger switch function is assigned to both of the M3 and M4 keys by default.

- If the BHT fails to read due to specular effects or other factors, change the scanning angle of the reading window or the distance from codes as shown at right, and try it again. (Specular effects occur when the reflection of the light from the bar code becomes excessively strong. This can easily happen when the reflecting surface is polished or covered with vinyl.)

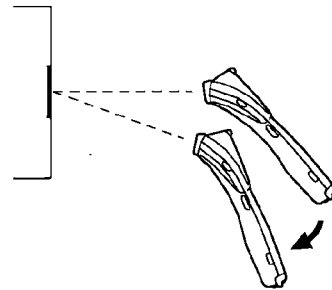

- Keep the BHT at a distance from a target bar code so that the bar code comes within approx. 90% of the laser scanning range (line length).
- The BHT can read bar codes at a maximum distance of 56 cm (22.0)** from the bar-code reading window.

**Under the following conditions:

- Ambient illuminance: 500 lx (Xenon lamp)
- ITF conforming to the UPC Shipping Container Code
- Reflection intensity: 85% min. for white and 5% max. for black
- Minimum narrow bar width: 1.0 mm min. (39.4 mils min.)

- The bar code reading procedure may differ depending upon the application used, so follow the application's manual.

NOTE

- Before reading bar codes, clean those labels if stained.
- Avoid using the BHT in direct sunlight. The BHT might fail to read correctly.
- To read bar codes on curved surfaces, apply the BHT to the target bar code so that the code comes to the center of the scanning range indicated by the laser beam.
- When you pull the bar-code reading window away from bar codes, the actual scanning range will become narrower than the range covered by the laser beam.

Radio Communication

- If connection is weak in radio communication, direct the BHT's antenna against any access point. Doing so may make communication good. This is because the BHT uses 2.4 GHz radio waves whose directivity is high and which do not transmit easily through human body.
- The BHT may fail to communicate by radio near a microwave oven, industrial heating facilities, high-frequency medical facilities, and other devices which use 2.4 GHz radio waves that the BHT uses.
- The BHT may fail to communicate near a PC, refrigerator and other domestic electric appliances due to electromagnetic noises caused by them.
- The BHT may fail to communicate in any environment where:
 - there are metallic objects or much metallic powders flying about,
 - surrounded with metallic walls, or
 - the BHT may be subjected to vibration.

NOTE

To system engineers:

- In some environments, the BHT may fail to communicate by radio. Make sure that the BHT can communicate without connection problems before introducing the BHT system into practical operation.
- Assuming possible communications failures, take special considerations in programming so that the BHT can transmit unsent data again.

Communicating via the Optical Interface

■ Communicating with the CU-7000

Put the BHT directly on the CU as shown below.

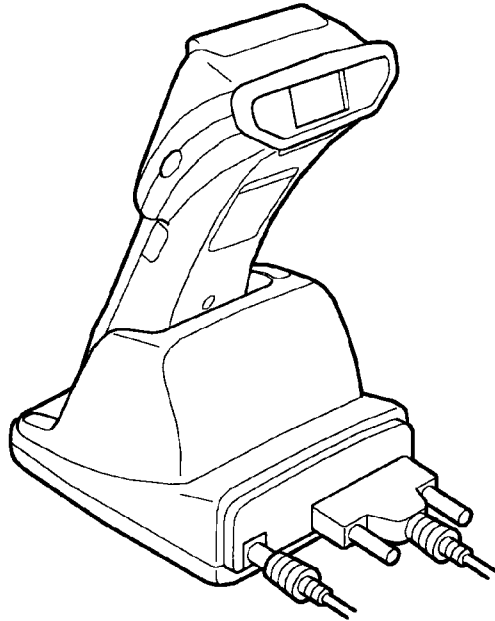

NOTE Communications failures might be caused by strong electromagnetic waves such as highly intensive light emitted from ceiling (inverter-driven fluorescent) lamps or direct sunlight. Take care to prevent such interference light from coming into the optical interface ports of the BHT and IrDA-compliant equipment, including the CU.

NOTE Do not use any TV remote control in the vicinity of the IR communications system. Doing so may interfere with the communications.

Setting the Backlight

Pressing the **M1** key while holding down **SF** (Shift) key activates or deactivates the backlight function.

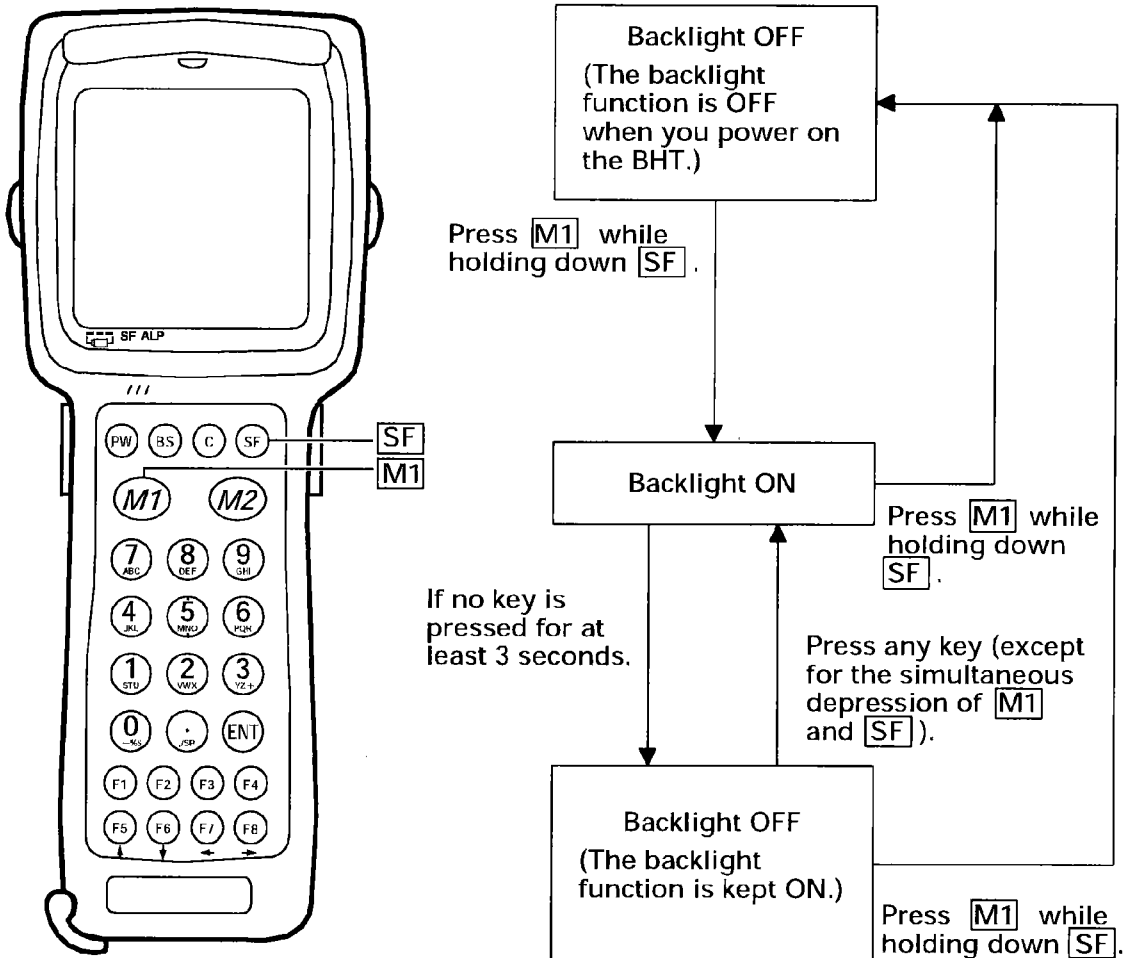

NOTE

In user programs, you can select the key to be used for activating or deactivating the backlight function (instead of the initial setting: combination of **SF** and **M1**), as well as modifying the ON-duration of the backlight before the automatic turning-off.

Adjusting the LCD Contrast & Beeper Volume and Switching the Beeper & Vibrator

While holding down the **M1** or **M4** key, press the **PW** key, and any of the following screens will appear on the LCD. This screen will disappear if no keys are pressed for five seconds.

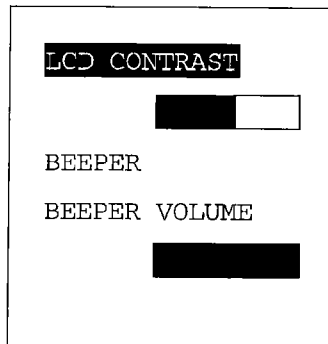

When the beeper is selected (default)

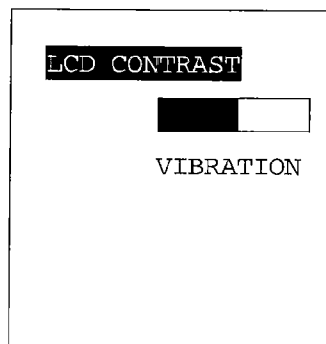

When the vibrator is selected

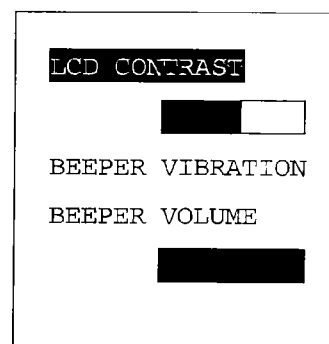

When both the beeper and vibrator are selected

(The current selection is highlighted.)

Adjusting the LCD contrast

You can adjust the LCD brightness to eight contrast levels.

- 1) Use the **▲*** and **▼*** keys to select the LCD CONTRAST line.
- 2) To decrease the contrast, press the **◀*** key; to increase it, press the **▶*** key.

Switching the beeper & vibrator

You may choose any of three ways—beeping only, vibrating only, or beeping & vibrating as a confirmation of completion of bar-code reading.

- (1) Use the **▲*** and **▼*** keys to select the BEEPER, VIBRATION, or BEEPER VIBRATION indication.
- (2) When the BEEPER is highlighted: Each time you press the **▶*** key, the BEEPER VIBRATION or VIBRATION will be selected alternately.

When the BEEPER VIBRATION is highlighted: Press the **◀*** or **▶*** key to select the BEEPER or VIBRATION, respectively.





When the VIBRATION is highlighted: Each time you press the **◀*** key, the BEEPER VIBRATION or BEEPER will be selected alternately.

Make sure that the desired setting is highlighted.









* For BHTs having a 26-key pad, use **F5**, **F6**, **F7** and **F8** keys instead of **▲**, **▼**, **◀**, and **▶** keys, respectively

Adjusting the beeper volume

You can adjust the beeper volume to four levels from OFF to MAX.

- 1) Use the * and * keys to select the BEEPER VOLUME line.
- 2) To turn down the volume, press the * key; to turn it up, press the * key.

After making the above setting, press the  key or press no keys for five seconds, and the new setting will be fixed and the above screen will disappear.

* For BHTs having a 26-key pad, use , ,  and  keys instead of , , , and  keys, respectively

About Status Indicators

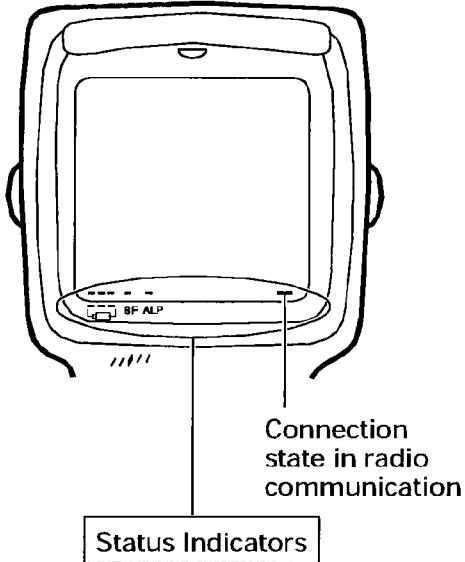

Battery voltage level

 Shows the current battery voltage level.

If the voltage level is high, three bars appear; if low, a single bar appears.

NOTE The displayed battery level shows the terminal voltage of the battery cartridge, not how much power is left.

The battery voltage level varies depending upon the operation of the BHT, so the displayed level also may vary .

Keypad shift state

SF Shows a bar when the keypad is shifted.

Alphabet input

ALP Shows a bar when the alphabet input function is activated.

Connection state in radio communication

Shows a bar when the BHT is synchronized with any access point.

Loading the Rechargeable Battery Cartridge

Before the first use of the BHT, be sure to load the rechargeable battery cartridge as shown below. The battery cartridge is not loaded in the BHT when shipped from the factory.

- (1) Charge the rechargeable battery cartridge.
- (2) Turn the BHT upside down.
- (3) As shown below, slide the battery cartridge into the BHT until it clicks into place. (To remove it, press the release button.)

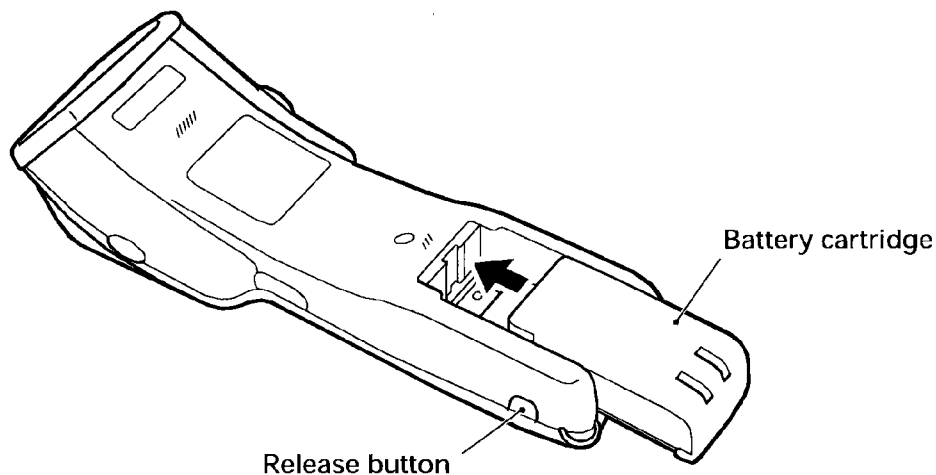

NOTE The BHT integrates a rechargeable backup power source which backs up the memory and calendar clock in the BHT when no battery cartridge is loaded or the voltage level of the battery cartridge drops below the specified level. The backup power source is automatically charged by the battery cartridge.

When you first load the battery cartridge after purchase or you load it after leaving the BHT unused for a long time, do not remove the battery cartridge for at least 10 minutes after that loading. This is for charging the memory backup source integrated in the BHT.

Battery Replacement Notes

■ When is battery replacement needed?

If the "Charge the battery!" appears on the LCD, replace the rechargeable battery cartridge with a fully charged one.

If you leave the BHT without replacing the battery cartridge, the integrated calendar clock or data will no longer be backed up so that the calendar clock will stop or the "Contact your administrator. Note the error number. (XXXX)" will appear on the LCD.

NOTE

Be sure to power off the BHT before battery replacement.

Replace the rechargeable battery cartridge quickly. Load a charged battery cartridge within 3 minutes after the removal in order to avoid data loss.

After battery replacement, power on the BHT and check the BHT operation.

■ If you will use the BHT more than one time per month:

Keep the rechargeable battery cartridge loaded in the BHT.

■ If you will not be using the BHT for more than one month:

Remove the rechargeable battery cartridge from the BHT and then store the BHT. To do so, be sure to follow the procedure given below.

(1) When removing the battery cartridge:

Press the **PW** key for more than 3 seconds to power off the BHT.

The following message will appear on the LCD and the BHT will start backing up data. After completion of the backup operation so that the message disappears, remove the battery cartridge.

(The backup operation may take several tens of seconds depending upon the volume of data to be backed up.)

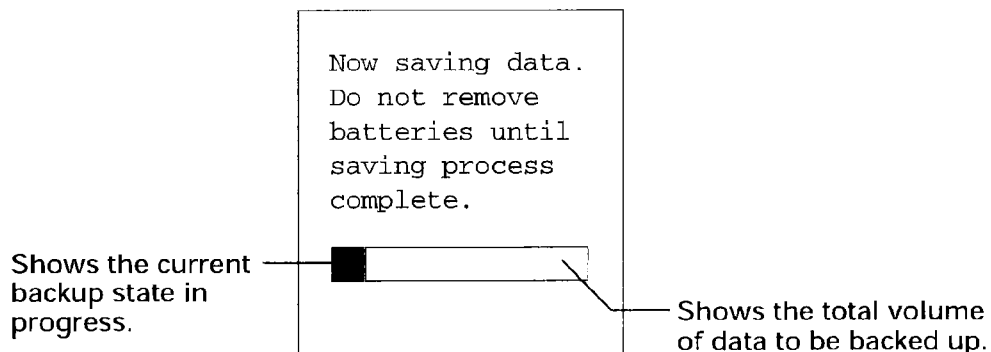

- (2) When powering on the BHT after storage with no battery cartridge loaded:

Even after removal of the rechargeable battery cartridge, the calendar clock will work with the backup power source for a while.

If the calendar clock backup has stopped, loading the battery cartridge and powering on the BHT will display the following message, prompting you to set the current date and time.

For details about the setting procedure, contact your system administrator.

(The indication "00/01/01 00:00" will vary depending upon the calendar clock state.)

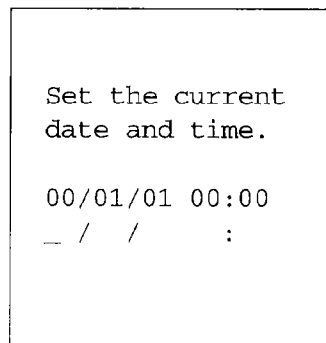

```
Set the current
date and time.

00/01/01 00:00
_ / /      :
```

Error Messages

If some error occurs when the power is turned on or during program execution, one of the following error messages will appear on the LCD.

System Program error

■ Problem

A System Program error has occurred.

NOTE If this error occurs, the BHT beeps five times (for 0.1 second per beep) and then turns itself off.

■ Solution

Contact your system administrator.

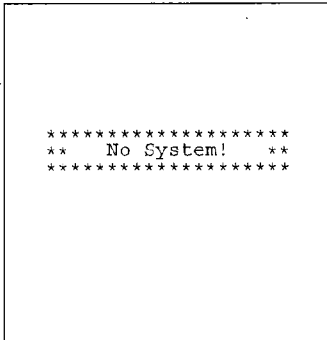

Low battery indication—Level 1

■ Problem

When the power is turned on or off or during execution of program (System Mode or application), the battery output level has dropped below a specified lower level limit.

NOTE If low battery is detected, the BHT displays this message for approx. 2 seconds and beeps three times (for 0.1 second per beep). After that, it will resume previous regular operation.

■ Solution

The service life of the rechargeable battery cartridge will expire soon, requiring replacement or recharge.

Replace it with a fully charged battery cartridge or charge it.

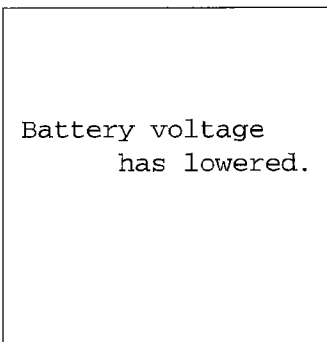

Charge the
battery!

Low battery indication—Level 2

■ Problem

When the power is turned on or during execution of program (System Mode or application), the battery output level has lowered.

NOTE If lower battery is detected, the BHT beeps five times (for 0.1 second per beep) and then turns itself off. Depending upon the battery level, the beeper may not sound five times.

■ Solution

Replace it with a fully charged battery cartridge or charge it.

Set the current
date and time.

00/01/01 00:00
_ / / :

Calendar clock stopped

■ Problem

The calendar clock integrated in the BHT has stopped because the rechargeable battery cartridge had been removed for a long time or had not been recharged for long time.

NOTE (The indication of 00/01/01 00:00 will change depending upon the calendar clock state.)

■ Solution

Contact your system administrator.

Your terminal was not shut down properly the last time it was used.

Unsaved data was lost.

[SF+2]

Abnormally powered off last

■ Problem

After powered off abnormally*, the BHT had been left with no battery cartridge loaded or with a discharged battery cartridge loaded, so unsaved data was lost.

(* "Normally powered off" refers to powered off with the PW key or by the auto power-off feature.)

■ Solution

Contact your system administrator.

Invalid file(s)

■ Problem

The BHT had not been normally powered off, so the contents of file(s) became invalid.

■ Solution

Contact your system administrator.

Scandisk found invalid files.

Refer to the file "\$\$BRKLST.SYS" for more information.

Execution program not selected

■ Problem

No user program has been selected as an execution program to be run when the power is turned on.

NOTE

If this error occurs, the BHT beeps five times (for 0.1 second per beep) and then turns itself off.

■ Solution

Contact your system administrator.

No execution program selected.
Contact your administrator.

System Program malfunction

```
Reload the battery
to restart!

XXXXXXXXX 01
```

■ Problem

During execution of System Program, the System Program has attempted to write onto the write-protected area of the memory.

(XXXXXXXXX: Error address)

NOTE If this error occurs, the BHT beeps five times (for 0.1 second per beep).

■ Solution

Unload and reload the rechargeable battery cartridge, then turn on the power. If this error occurs frequently, contact your system administrator.

```
Reload the battery
to restart!

tskid:XXXXXXXX
ercd :XXXXXXXX
addr :XXXXXXXX 02
```

■ Problem

During execution of System Program, the System Program has received an invalid command code.

(XXXXXXXXX: Error address)

NOTE If this error occurs, the BHT beeps five times (for 0.1 second per beep).

■ Solution

Unload and reload the rechargeable battery cartridge, then turn on the power. If this error occurs frequently, contact your system administrator.

Resume data lost

■ Problem

No resume data has been retained since the BHT was not normally powered off and then left with no battery cartridge loaded or with a discharged battery cartridge loaded even if the resume function had been set to ON.

NOTE The BHT displays this error message for three seconds and automatically runs the execution program from the point of start-up.

```
No resume info.
has been retained.
Program restarts
automatically.
```

Your settings in
System Mode
have been lost.

Will reset
to defaults.

Error in System Mode settings

■ Problem

Your settings made in System Mode contain an error.

NOTE If this error occurs, the System Mode settings revert to the factory defaults.

TIP The BHT displays this error for three seconds and then displays the “No execution program selected...” message.

■ Solution

Contact your system administrator.

System down error

■ Problem

An error has occurred during execution of System Program.

NOTE If this error occurs, the BHT beeps five times (for 0.1 second per beep).

■ Solution

Unload and reload the rechargeable battery cartridge, then turn on the power.

If this error occurs frequently, contact your system administrator.

System down error!

```
type:XXXXXXXX R0 :XXXXXXXX
ercd:XXXXXXXX R1 :XXXXXXXX
inf1:XXXXXXXX R2 :XXXXXXXX
inf2:XXXXXXXX R3 :XXXXXXXX
                R4 :XXXXXXXX
SR  :XXXXXXXX R5 :XXXXXXXX
PC  :XXXXXXXX R6 :XXXXXXXX
PR  :XXXXXXXX R7 :XXXXXXXX
                R8 :XXXXXXXX
                R9 :XXXXXXXX
                R10:XXXXXXXX
                R11:XXXXXXXX
                R12:XXXXXXXX
                R13:XXXXXXXX
                R14:XXXXXXXX
                R15:XXXXXXXX
```

System administrator to be called

Contact your
administrator.
Note the error
number.
(XXXX)

■ **Problem**

Any of the following errors has occurred:

- (1) Hardware error or calendar clock error: (1010)
Flash memory error: (1020)
- (2) Memory storage error (2XXX)
- (3) Execution program error (3010)

(XXXX: Error code)

NOTE If any of the above errors occurs, the BHT beeps five times (for 0.1 second per beep) and then turns itself off.

■ **Solution**

Turn on the power again. If this error occurs frequently, contact your system administrator.

Proper Care of the BHT

Clean the housing and the rechargeable battery cartridge terminals with a dry, soft cloth. Before cleaning, be sure to power off the BHT.

- Never use benzene, alcohol, or other organic solvents. The housing may be marred or the paint may come off.
- Never rub or strike the liquid crystal display (LCD) with anything hard. The LCD surface will be easily scratched or broken.
- When cleaning the keypad, do not scrub the surface too hard, and do not pull on the keys. Doing so may break the keys or cause the keypad to dislocate.
- If the BHT becomes smudged, moisten a soft cloth with neutral detergent and wring it out thoroughly. Wipe the BHT with the cloth and then go over it again with a dry cloth.

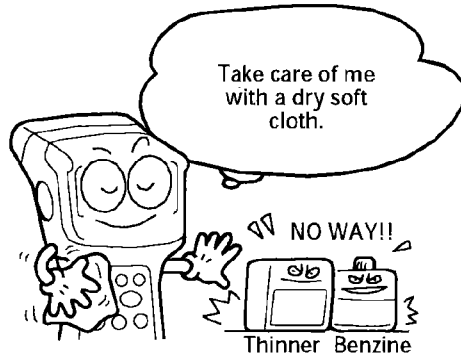

Dust or dirt accumulating on the clear plate of the bar-code reading window will affect reading performance. If you use the BHT in dusty areas, therefore, periodically check the clear plate of the bar-code reading window and clean it if dusty.

- To clean the plate, first blow the dust away with an air brush. Then wipe the plate with a cotton swab or the similar soft one gently.
- If sand or hard particles have accumulated, never rub the plate; doing so will scratch or damage it. Blow the particles away with an air brush or a soft brush.

Handling Notes

- An early upload of gathered data is recommended, since the data stored in the RAM might be affected by the so-called "soft error" or other environmental phenomena. In some cases, the "Contact your administrator." will appear on the LCD.
- Do not use the BHT near a personal or amateur radio device. Doing so may cause the BHT to malfunction.
- Avoid storing the rechargeable battery cartridge in a hot place. The battery capacity may be decreased.
- Do not touch the charge terminals of the battery cartridge by hand or stain those terminals. Doing so could result in a charging failure.
- Use a dedicated rechargeable battery cartridge for the BHT. Do not use a dry battery cartridge.
- When connecting or disconnecting the direct-connect interface cable to/from the BHT, do not plug or unplug at an angle and do not pull the cable strongly. Doing so will result in a machine failure.
- Do not use the BHT near a magnet or device that generates strong magnetic field. Doing so will deflect the optical axis of the laser beam, resulting in a reading failure or machine trouble.
- If the BHT has been stored in a hot (50°C to 60°C, 122°F to 140°F) and humid place, allow it to sit at room temperature and humidity for at least one day before use. Using the BHT with its inside being hot will fail to scan or result in a machine failure.

FCC and RSS-210 Regulations

This Device complies with Part 15 of the FCC Rules and RSS-210 Rules.

Operation is subject to following two conditions :

- (1) this device may not cause harmful interference, and
- (2) this device must accept any interference received, including interference that may cause undesired operation.

FCC WARNING : Changes or modifications not expressly approved by the party responsible for compliance could void the user's authority to operate the equipment.

Labeling

FCCID:HYQBHT-7500S
CANADA:XXXXXXXXXX
RSS-210

THIS DEVICE COMPLIES WITH PART 15 OF THE FCC RULES. OPERATION IS SUBJECT TO THE FOLLOWING TWO CONDITIONS: (1) THIS DEVICE MAY NOT CAUSE HARMFUL INTERFERENCE, AND (2) THIS DEVICE MUST ACCEPT ANY INTERFERENCE RECEIVED, INCLUDING INTERFERENCE THAT MAY CAUSE UNDESIREED OPERATION.

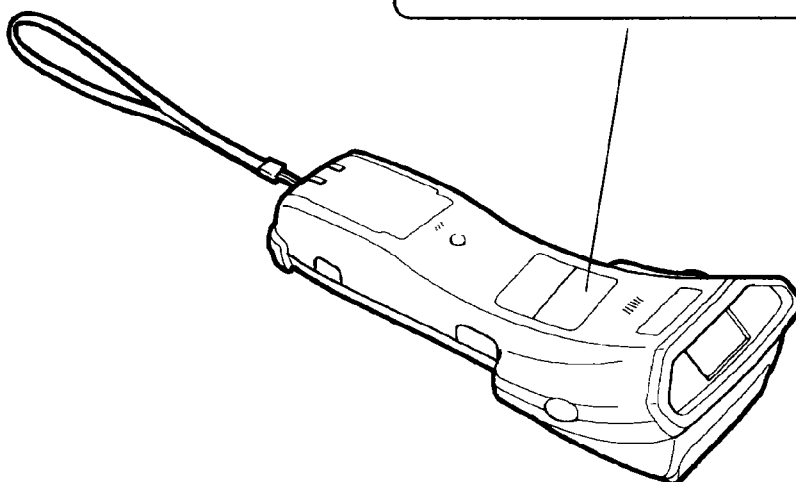

DENSO CORPORATION

1-1 Showa-cho, Kariya-shi, Aichi-ken, Japan 448-8661

496487-0000