



HEARTH PRODUCTS

VENTED GAS FIREPLACE

INSTALLATION AND OWNER'S OPERATION MANUAL

4" B-VENT DECORATIVE GAS FIREPLACES

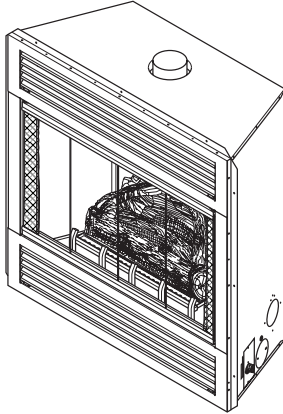

MODELS

(V)CB36N(E) AND (V)CB36P(E)

⚠ WARNING: If the information in this manual is not followed exactly, a fire or explosion may result causing property damage, personal injury or loss of life.

- Do not store or use gasoline or other flammable vapors and liquids in the vicinity of this or any other appliance.
- **WHAT TO DO IF YOU SMELL GAS**
 - Do not try to light any appliance.
 - Do not touch any electrical switch; do not use any phone in your building.
 - Immediately call your gas supplier from a neighbor's phone. Follow the gas supplier's instructions.
 - If you cannot reach your gas supplier, call the fire department.
- Installation and service must be performed by a qualified installer, service agency or the gas supplier.

INSTALLER: Leave this manual with the appliance
CONSUMER: Retain this manual for future reference.

For more information, visit www.desatech.com

TABLE OF CONTENTS

Safety	2	Inspecting Burners.....	23
Product Identification.....	4	Cleaning and Maintenance.....	24
Local Codes.....	4	Specifications	25
Product Features.....	5	Service Hints.....	25
Pre-Installation Preparation.....	5	Technical Services.....	25
Installation Precautions	9	Troubleshooting.....	26
Venting Installation	9	Replacement Parts.....	31
Installing Optional Controls.....	12	Accessories.....	31
Fireplace Installation.....	15	Parts	32
Operating Fireplace.....	20	Warranty.....	Back Cover

SAFETY

⚠ WARNING: Improper installation, adjustment, alteration, service or maintenance can cause injury or property damage. Refer to this manual for correct installation and operational procedures. For assistance or additional information consult a qualified installer, service agency or the gas supplier.

This appliance may be installed in an aftermarket,* permanently located, manufactured (mobile) home, where not prohibited by local codes.

This appliance is only for use with the type of gas indicated on the rating plate. This appliance is not convertible for use with other gases.

* Aftermarket: Completion of sale, not for purpose of resale, from the manufacturer

State of Massachusetts:
The installation must be made by a licensed plumber or gas fitter in the Commonwealth of Massachusetts.

⚠ WARNING: This product contains and/or generates chemicals known to the State of California to cause cancer or birth defects or other reproductive harm.

IMPORTANT: Read this owner's manual carefully and completely before trying to assemble, operate or service this fireplace. Improper use of this fireplace can cause serious injury or death from burns, fire, explosion, electrical shock and carbon monoxide poisoning.

⚠ DANGER: Carbon monoxide poisoning may lead to death!

SAFETY

Continued

This fireplace is a vented product. This fireplace will not produce any gas leakage into your home if properly installed. This fireplace must be installed by a qualified (certified or licensed) service person. If this unit is not properly installed by a qualified service person gas and/or carbon monoxide leakage (spillage) can occur.

Carbon Monoxide Poisoning: Early signs of carbon monoxide poisoning resemble the flu, with headaches, dizziness or nausea. If you have these signs, the fireplace may not be working properly. **Get fresh air at once!** Have fireplace serviced. Some people are more affected by carbon monoxide than others. These include pregnant women, people with heart or lung disease or anemia, those under the influence of alcohol and those at high altitudes.

Natural and Propane/LP Gas: Natural and propane/LP gases are odorless. An odor-making agent is added to these gases. The odor helps you detect a gas leak. However, the odor added to the gas can fade. Gas may be present even though no odor exists.

Make certain you read and understand all warnings. Keep this manual for reference. It is your guide to safe and proper operation of this heater.

 **WARNING: Any change to this fireplace or its controls can be dangerous.**

 **WARNING: Do not use a blower insert, heat exchanger insert or other accessory not approved for use with this fireplace.**

 **WARNING: Do not allow fans to blow directly into the fireplace. Avoid any drafts that alter burner flame patterns. Ceiling fans can create drafts that alter burner flame patterns. Altered burner patterns can cause sooting.**

Due to high temperatures, the appliance should be located out of traffic and away from furniture and draperies.

Do not place clothing or other flammable material on or near the appliance. Never place any objects on or around fireplace.

Fireplace reaches high temperatures. Keep children and adults away from hot surface to avoid burns or clothing ignition. Fireplace will remain hot for a time after shutdown. Allow surfaces to cool before touching.

Do not operate fireplace with glass door removed, cracked or broken.

Carefully supervise young children when they are in the room with the fireplace.

Keep the appliance area clear and free from combustible materials, gasoline and other flammable vapors and liquids.

This product is intended only as a supplement to your central heating system and is not to be installed as a primary source of heat. You may use this product for emergency heating during a power outage.

1. This appliance is only for use with the type of gas indicated on the rating plate. This appliance is not convertible for use with other gases unless a certified kit is used.
2. Do not place propane/LP supply tank(s) inside any structure. Locate propane/LP supply tank(s) outdoors (propane/LP units only).

SAFETY

Continued

- If you smell gas
 - shut off gas supply
 - do not try to light any appliance
 - do not touch any electrical switch; do not use any phone in your building
 - immediately call your gas supplier from a neighbor's phone. Follow the gas supplier's instructions
 - if you cannot reach your gas supplier, call the fire department
- Never install the fireplace
 - in a recreational vehicle
 - in windy or drafty areas where curtains or other combustible (flammable) objects can make contact with the fireplace front
 - in high traffic areas
- Do not modify this fireplace under any circumstances. Any parts removed for servicing must be replaced prior to operating fireplace.
- Turn fireplace off and let cool before servicing, installing or repairing. Only a qualified service person should install, service or repair this fireplace.
- You must keep control compartments, burners and circulating air passages clean. More frequent cleaning may be needed due to excessive lint and dust from carpeting, bedding material, etc. Turn off the gas valve and pilot light before cleaning fireplace.
- Have fireplace and venting system inspected annually by a qualified service person. If needed, have venting system cleaned or repaired. See *Cleaning and Maintenance*, page 24.
- Do not use this fireplace to cook food or burn paper or other objects.
- Do not use any solid fuels (wood, coal, paper, cardboard, etc.) in this fireplace. Use only gas type indicated on nameplate.
- This appliance, when installed, must be electrically grounded in accordance with local codes or, in the absence of local codes, with the *National Electric Code, ANSI/NFPA 70*, or the *Canadian Electric Code, CSA C22.1*.
- Do not use fireplace if any part has been exposed to or under water. Immediately call a qualified service technician to arrange for replacement of the unit.
- Do not operate fireplace if any log is broken or missing.
- To prevent performance problems, do not use propane/LP fuel tank of less than 100 lb. (45 kg) capacity (propane/LP units only).
- Provide adequate clearances around air openings.

PRODUCT IDENTIFICATION

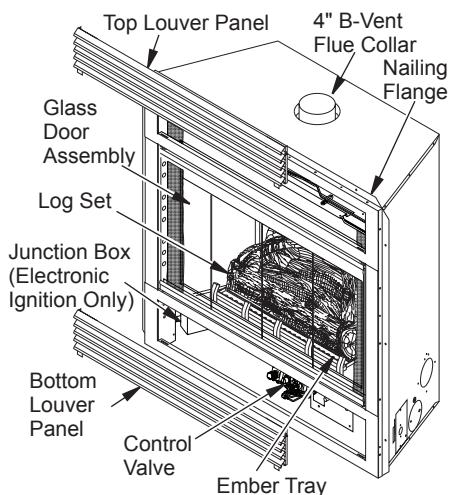

Figure 1 - B-Vent Fireplace

LOCAL CODES

Install and use fireplace with care. Follow all local codes. In the absence of local codes, use the latest edition of *The National Fuel Gas Code ANSI Z223.1/NFPA 54** (USA) or the current *CSA-B149.1 Installation Code* (Canada).

*Available from:

American National Standards Institute, Inc.
1430 Broadway
New York, NY 10018

National Fire Protection Association, Inc.
Battery March Park
Quincy, MA 02269

PRODUCT FEATURES

These are a few facts that can help you understand and enjoy your vented decorative fireplace:

- The (V)CB36N(E) and (V)CB36P(E) series of vented decorative fireplaces may be recessed into an exterior chase, an interior flush wall enclosure or a framed-in corner installation.
- Models (V)CB36N and (V)CB36P are equipped with a millivolt gas control system that does not require electricity to operate. A piezo ignitor is provided to light the pilot without using matches or lighters.
- Models (V)CB36N(E) and (V)CB36P(E) are equipped with an electronic ignition system that requires 120 VAC to operate. An electrode ignitor automatically lights the pilot flame when the fireplace is turned on.
- These fireplaces can accept any approved 4" B-Type venting system and must be terminated vertically through the roof using a listed type vent cap only. See venting instructions starting on page 8 for proper venting requirements.
- These vented fireplaces require indoor air for combustion and must be installed in a room of sufficient size to provide adequate fresh air for safe and proper operation. The room intended for installation must be of sufficient size to meet the requirements for an unconfined space as defined in the *National Fuel Gas Code, ANSI Z223.1/NFPA 54, Air for Combustion and Ventilation*. If sufficient air for combustion is not available a makeup air kit model AK4 may be required to provide outside air to this appliance. Check your local codes as to specific requirements for make up air.
- This fireplace may be installed in any room of the house provided all local codes and these installation instructions are followed.

PRE-INSTALLATION PREPARATION

LOCATION AND SPACE REQUIREMENTS

Determine the safest and most efficient location for your DESA Heating, LLC direct-vent fireplace. Make sure that rafters and wall studs are not in the way of the venting system. Choose a location where the heat output is not affected by drafts, air conditioning ducts, windows or doors. Figure 2 shows some common locations. Be aware of all restrictions and precautions before deciding the exact location for your fireplace and termination cap.

When deciding the location of your fireplace, follow these rules:

- Do not connect this fireplace to a chimney flue servicing a separate solid fuel burning fireplace or appliance.
- Do not install in high traffic areas, windy or drafty areas, or near furniture or draperies.
- Proper clearances must be maintained.
- If your fireplace is to be installed directly on carpeting, vinyl, tile or any combustible material other than wood, it must be installed on a metal or wood panel extending the full width and depth of the fireplace (see Figure 3).

- Only trim kits supplied by DESA Heating, LLC shall be used in the installation of this fireplace, see [Accessories](#), page 31.
- Do not install aftermarket vent dampers. Manual or automatic vent dampers are not approved for use with this appliance.

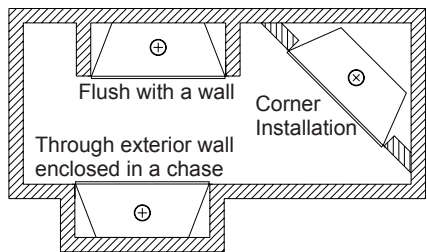

Figure 2 - Common Fireplace Locations

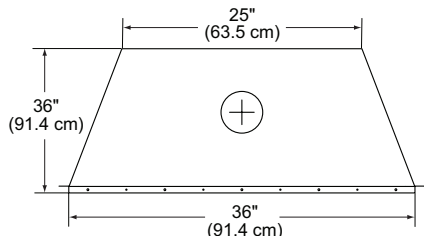

Figure 3 - Fireplace Bottom Dimensions

PRE-INSTALLATION PREPARATION

Continued

- Your fireplace is designed to be used in zero clearance installations. Wall or framing material can be placed directly against any exterior surface on the back, sides or top of your fireplace, except when clearances are required from flue vent pipe, see [Clearances](#).
- If recessed into a wall, you can avoid extra framing by positioning your fireplace against an already existing framing member.
- A hearth extension is not required with this appliance. If one is installed, it is for aesthetic purposes only and does not have to meet standard requirements for hearth extensions.
- If you plan on installing a television or entertainment center recessed above your fireplace, it is recommended that you maintain a minimum 18" (45.7 cm) above the top of louver opening.
- When locating the termination cap, it is important to observe the minimum vent height and clearances required under code, see [Venting Installation Instructions](#), page 9.
- Do not recess termination cap into a wall or siding.
- You may paint the termination cap with 450° F (232° C) heat resistant paint to coordinate with the exterior finish.

PACKAGING AND REMOVAL

The (V)CB36 vented decorative gas fireplaces are packaged with the following items:

- one box containing a 4 piece log set located on the burner in the firebox.
 - one bag containing the owner's manual with installation instructions, operator's guide, and warranty information.
 - one bag of glowing ember material.
 - one bag of vermiculite hearth treatments.
1. Remove shrink wrap securing 2 carton trays to unit.
 2. Lift top carton tray off and remove four corner posts.
 3. Discard bottom tray once unit is moved into position.

Note: To prevent damage to ceramic logs and glass panels you may want to remove them before positioning and framing the unit. To access firebox, see [Louver Panels and Glass Door](#), page 17.

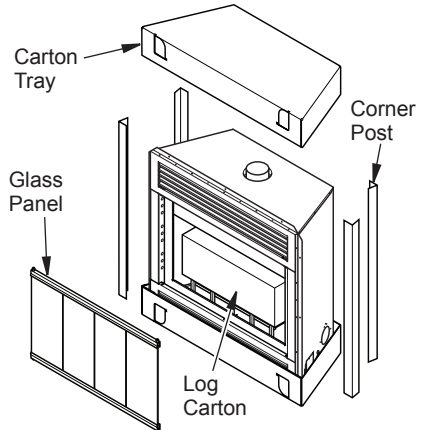

Figure 4 - Unpacking Fireplace

CLEARANCES

Minimum clearances to combustibles for fireplace:

Back, Sides, Floor and Top	0" (0 mm)
Perpendicular walls	10" (25.4 cm)
Ceiling to Louver & Front	36" (91.4 cm)
B-Vent Surfaces	1" (26 mm) (See venting instructions for specifics on vent clearances.)

Mantel Clearances (See [Mantel Clearances](#), page 8, for specific clearances to combustible mantels.)

Combustible material with a maximum thickness of 5/8" (16 mm) may be flush with top and sides of front face of fireplace.

FRAMING AND FINISHING

Figure 5, page 7, shows typical framing of this fireplace. Figure 6, page 7, shows framing for corner installation. All minimum clearances must be met.

For overall unit dimensions, framing allowances and vent collar locations, see Figure 7 on page 7.

For available accessories for this fireplace, see [Accessories](#), page 31. If you are using a separate combustible mantel piece, refer to Figures 8 and 9, page 8, for proper height and clearances. You can install a noncombustible mantel at any height above the fireplace opening.

Note: Noncombustible mantels may discolor!

PRE-INSTALLATION PREPARATION

Continued

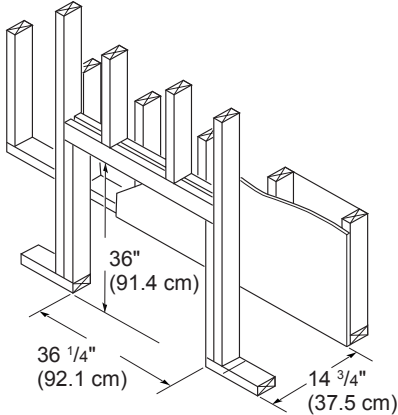
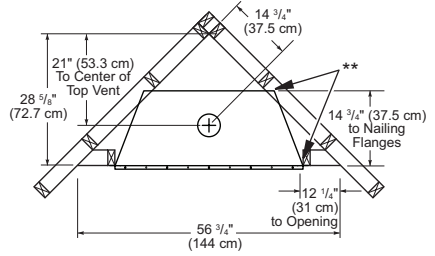

Figure 5 - Framing Clearances for Flush Wall Installation



**These dimensions allow for 1" clearance at sides and back of fireplace. However, 0" clearance is also permitted at all sides when framed.

Figure 6 - Framing Clearances for Corner Installation

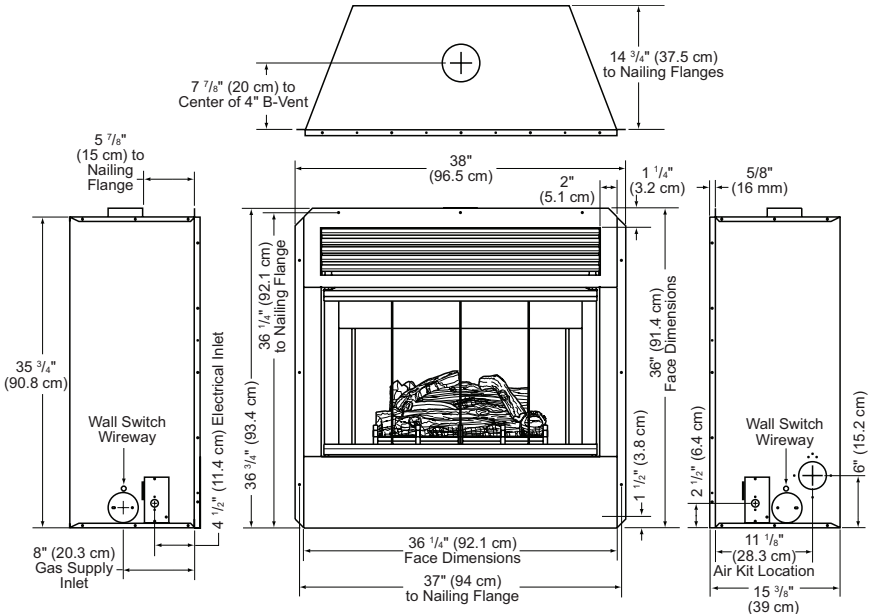

Figure 7 - Unit Dimensions

PRE-INSTALLATION PREPARATION

Continued

MANTEL CLEARANCES

Figure 8 shows projected mantel depths at various heights above top of louver opening. Figure 7, page 7, shows minimum allowable distances from various mantel components in relation to both sides of fireplace opening.

⚠ WARNING: When finishing appliance do not overlap combustible materials onto the black front face. Brick, tile or other noncombustible materials may be applied to the face provided that any fireplace openings are not blocked and gaps in the material used and the face are sealed with a noncombustible caulking.

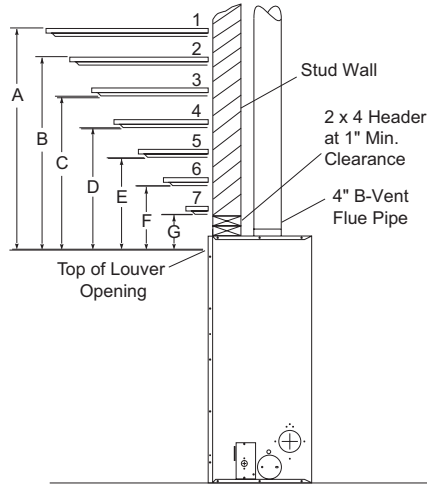

Ref.	Mantel Depth	Ref.	Mantel from Top of Louver Opening
1	16" (40.6 cm)	A	18" (45.7 cm)
2	14" (35.6 cm)	B	16" (40.6 cm)
3	12" (30.5 cm)	C	14" (35.6 cm)
4	10" (25.4 cm)	D	12" (30.5 cm)
5	8" (20.3 cm)	E	10" (25.4 cm)
6	4" (10.2 cm)	F	8" (20.3 cm)
7	2" (5.1 cm)	G	6" (15.2 cm)

Figure 9 - Clearances for Combustible Mantels

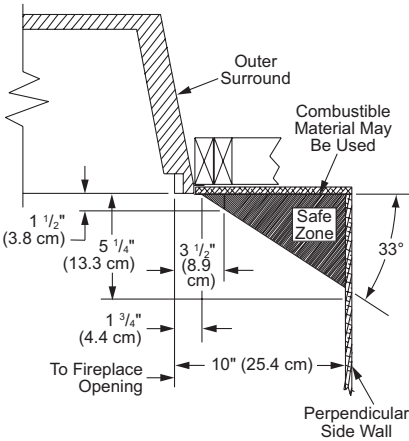

Figure 8 - Side Clearances for Combustible Mantels

INSTALLATION PRECAUTIONS

NOTICE: Failure to follow these instructions will void the warranty.

- Wear gloves and safety glasses for protection
- Use extreme caution when using ladders or when on roof tops
- Be aware of electrical wiring locations in walls and ceilings

The following actions will void the warranty on this product:

- Installation of any damaged venting component
- Unauthorized modification of the venting system (Do not cut or alter vent components)
- Installation of any component part not manufactured or approved by DESA Heating, LLC
- Installation other than as instructed by these instructions

⚠ WARNING: Read all instructions completely and thoroughly before attempting installation. Failure to do so could result in serious injury, property damage or loss of life.

⚠ WARNING: B-type vent pipe airspace clearance to combustibles is 1" on all sides. Where the vent pipe passes through a vertical wall a listed thimble approved for use with B-type vent must be used.

VENTING INSTALLATION

A 4" B-type venting system must be connected to the appliance for venting to the outside of the building.

The following section is provided as a guide to install a standard B-type vent installation.

Standing code requirements concerning B-type vent installations may vary within your state, province or local codes jurisdiction. Therefore, it is recommended that you check with your local building code authority for specific requirements or in absence of local codes, follow Section 7.0 of the current *National Fuel Gas Code NFPA 54/ANSI Z223.1* or in Canada with *CAN/CSA B149* for Category I systems using double wall B-1 vent pipe.

This gas appliance must be vented to the outdoors only and may not be terminated into an attic space or into a chimney flue servicing a solid fuel burning appliance.

This appliance may be vented through a manufactured chimney liner system if all are listed, inspected and approved by local codes and/or building authorities.

The examples shown in Figure 10, page 10, are typical of most B-vent installations and code practices.

⚠ WARNING: This gas fireplace and vent assembly must be vented directly to the outside. The venting system must NEVER be attached to a chimney serving a separate solid fuel burning appliance.

Example 1: Shows the minimum allowable system height and lateral offset for a 60° or greater inclination. Code specifies that offsets at 60° or greater are considered horizontal and must follow the 75% rule for lateral to total vertical system height. Codes also allows only one offset in the total system when at 60° or greater. The total vertical height in this example represents the minimum height of 8 feet and therefore the allowable lateral is 6 feet when the 75% rule applies. If the lateral length must exceed 75% then the system must be sized in accordance with the Category I venting tables.

Example 2: Shows multiple offsets each at 45° of inclination. Multiple offsets are permitted if they do not exceed 45° of inclination. The total lengths of the two offsets are not required to meet the 75% rule.

Example 3: Shows a single offset at 45° of inclination and therefore the lateral length at 10 feet of offset does not have to meet the 75% allowable rule.

VENTING INSTALLATION

Continued

In each case the offsets must be supported and firestops must be positioned wherever the vent must pass through a sub-floor, ceiling joist or an attic overhang. The vent pipe must terminate vertically into a listed type vent cap and extend a sufficient height through an approved roof flashing, roof jack or a roof thimble. At all points the listed clearances must be maintained.

Vent terminations must be located in accordance with height and proximity rules of *NFPA No. 54* or *CAN/CSA B149*. These rules apply to vents at 12" diameter or less and require a minimum height in accordance with the roof pitch and a minimum of 8 foot distance from a vertical wall or obstruction (see Figure 11).

If venting horizontally through a side wall becomes necessary, a listed thimble approved for use with B-type vent must be used. Check with your local codes before venting through a side wall.

Some codes areas allow the use of existing B-type vent systems if the system is at or above the recommended diameter of the flue.

The flue connection must be made using listed B-type connectors and the existing system must be code inspected for damage and proper installation.

It is not recommended that this appliance be common vented with an existing gas burning appliance. However, if it becomes necessary to common vent the appliance. The venting system must be sized and configured in accordance with the common venting guides Appendix G of the current *National Fuel Gas Code NFPA No. 54/ANSI Z223.1* and in Canada with *CAN/CSA B149*.

Note: Before connecting this appliance to an existing vent system or a common venting system consult with your local architect planner, or building official.

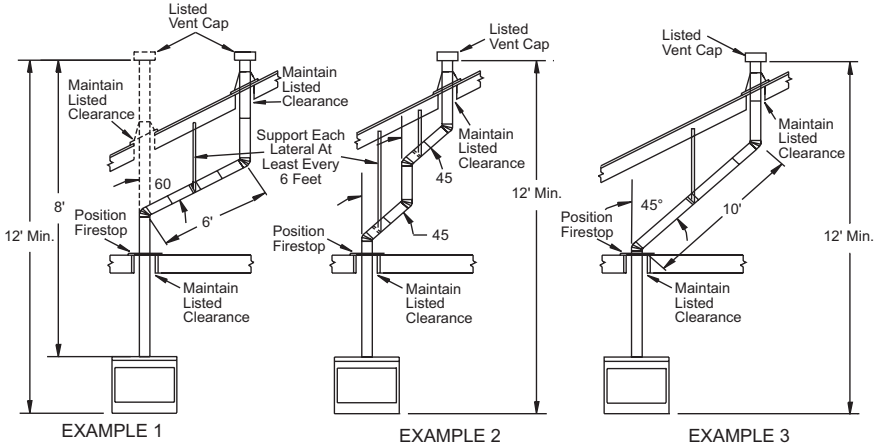
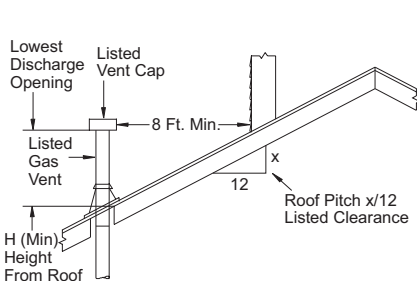

Figure 10 - Typical B-Vent Configuration



Roof Pitch	H (Min.)
Flat to 6/12	1.0 ft (0.3 m)
6/12 to 7/12	1.25 ft (0.38 m)
Over 7/12 to 8/12	1.5 ft (0.46 m)
Over 8/12 to 9/12	2.0 ft (0.61 m)
Over 9/12 to 10/12	2.5 ft (0.76 m)
Over 10/12 to 11/12	3.25 ft (0.99 m)
Over 11/12 to 12/12	4.0 ft (1.22 m)
Over 12/12 to 14/12	5.0 ft (1.52 m)
Over 14/12 to 16/12	6.0 ft (1.83 m)
Over 16/12 to 18/12	7.0 ft (2.13 m)
Over 18/12 to 20/12	7.5 ft (2.27 m)
Over 20/12 to 21/12	8.0 ft (2.44 m)

Figure 11 - B-Vent Termination

VENTING INSTALLATION

Continued

CHECKING FOR PROPER VENTING

After completing and checking electrical, gas and vent connections, follow lighting instructions and allow main burner to run for approximately 5 minutes. Hold a match or butane lighter flame, near opening between glass and fireplace face and play it along entire length of opening (Smoke may also be used). Proper venting will tend to draw flame or smoke into appliance. Improper venting, escaping or spillage of burned gas, is indicated when match flickers or goes out (see Figure 12). Smoke will also tend to disperse away from appliance.

If appliance is not venting properly, shut it off and notify your installer or a qualified service agency to inspect venting system.

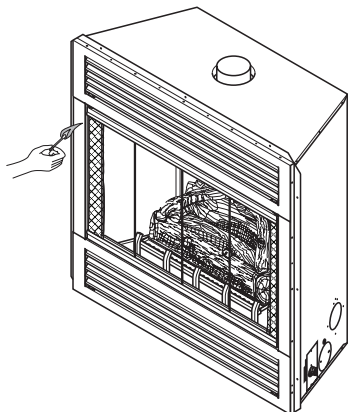

Figure 12 - Checking for Spillage

ELECTRICAL SUPPLY CONNECTION

CAUTION: Disconnect the electrical power to the supply circuit before attempting to connect or service this appliance.

A prewired junction box receptacle with strain relief is provided on right side of cabinet for hard wiring unit to a 15 Amp, 120 VAC, 60 Hz grounded branch circuit. If installation demands electrical supply be connected from the left, the entire receptacle box can be relocated to the left side by following these instructions:

Note: If you do not need to relocate the junction box, to connect the electric supply follow steps 8 through 11 only:

1. Remove 2 screws and outer cover with strain relief bushing on right side of cabinet (see Figure 13).
2. Remove inner retaining screw on junction box mounting tab.
3. Slide junction box up until screw mounting tab is lined up to notch in outer cabinet.
4. Swing junction box out and slip retaining flange out through slot in outer cabinet.
5. Remove 2 screws and outer cover on left side of outer cabinet.
6. Reinsert junction box retaining flange through slot now on left side and swing screw mounting tab back through notch as before.
7. Slide junction box down till mounting tab holes line up and replace inner retaining screw.
8. With junction box cover removed, pull end of 3-wire Romex supply line through universal strain relief bushing on cover. (see Figure 13).
9. Strip back outer Romex to about 4" and connect black, white and green wires accordingly using 3 wire nut connectors.
10. Tuck tailing wires into junction box and replace junction box cover using 2 remaining screws.
11. Tighten adjustment on universal strain bushing to secure Romex sheathing and complete supply connection.

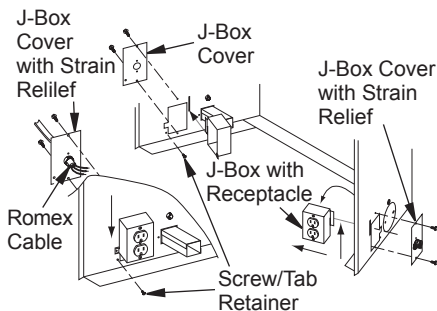

Figure 13 - Relocating Junction Box Receptacle and Electrical Supply Connection

VENTING INSTALLATION

Continued

⚠ WARNING: This appliance, when installed must be electrically grounded in accordance with local code or in the absence of local code, with the current *National Electric Code, ANSI/NFPA 70, or the Canadian Electric Code, CSA C22.1.*

HIGH ALTITUDE INSTALLATION

Your DESA Heating, LLC direct-vent fireplace has been tested and approved in the USA for elevations from 0-2,000 feet (610 m) and in Canada at elevations from 0-4,500 feet (1,372 m).

INSTALLING OPTIONAL CONTROLS

INSTALLING OPTIONAL WALL MOUNT SWITCH - GWMS2

1. Connect one terminal of 15 foot wire from wall switch to male connector on high limit harness. Connect remaining wire terminal to TH terminal on valve. Make sure that wire terminals are in positions on unit as pictured in Figure 14. If wires are not connected as shown switch will not work.
2. Route 15 foot wire through hole openings with bushings provided on either side of fireplace cabinet.
3. Connect one bare wire end to each of terminals of GWMS2 wall switch.
4. Install wall switch and cover in wall.

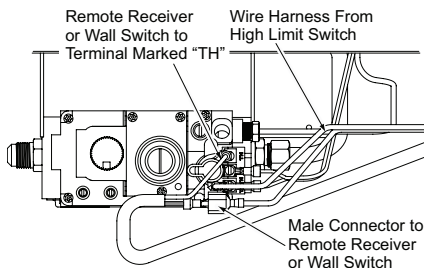

Figure 14 - Connecting Remote Receiver or Wall Switch to the Gas Control Valve

When installing a non-high altitude fireplace at an elevation above 2,000 feet (610 m) (in the USA), you may need to decrease the input rating by changing the existing burner orifice to a smaller size. Reduce input 4% for each 1,000 feet (305 m) above sea level. Check with your local gas company for proper orifice size identification.

When installing this fireplace in Canada at an elevation above 4,500 feet (1,372 m), Check with local or provincial code authorities.

Consult your local gas company to help determine the proper orifice for your location.

For assistance with any high altitude installation contact DESA Heating, LLC's Customer Service Department at 1-866-672-6040.

IMPORTANT: Do not use any other wire than that provided with GWMS2 wall switch kit. Do not exceed 15 feet of distance from valve connection. Using wire of higher gauge or turns or exceeding minimum distance will increase resistance at control valve causing unreliable performance of fireplace controls.

INSTALLING OPTIONAL WIRELESS HAND-HELD REMOTE CONTROL MODEL HRC100

Installing Remote Receiver

1. Open bottom louver and locate switch bracket on right side.
2. Locate battery clip mounted on back of receiver. Slide a 9-volt alkaline battery (not included) through clip.
3. Attach terminal wires to battery (see Figure 15).

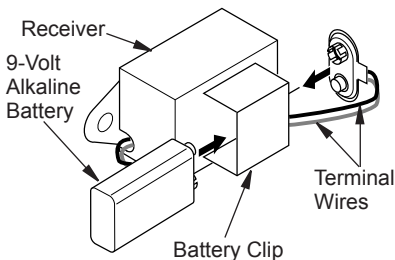

Figure 15 - Attaching Alkaline Battery to Receiver

INSTALLING OPTIONAL CONTROLS

Continued

4. Connect one wire from receiver to male connector on high limit harness and one to "TH" on control valve (see Figure 14, page 12).
5. Locate two plastic mounting clips provided with kit.
6. Use clips to mount receiver on remote mounting bracket as shown in Figure 16.

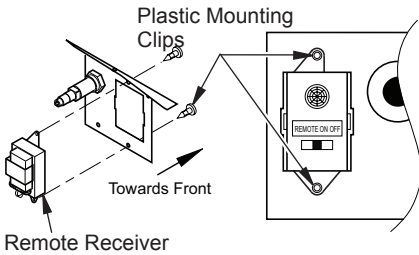

Figure 16 - Mounting Remote Receiver to Bracket

Installing 9-Volt Alkaline Battery in Hand-Held Remote Control Unit

1. Remove battery cover on back of remote control unit.
2. Attach terminal wires to a 9-volt alkaline battery (not included). Place battery into battery housing (see Figure 17).
3. Replace battery cover onto remote control unit.

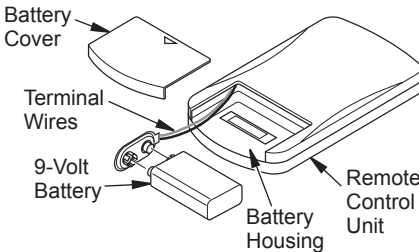

Figure 17 - Installing Battery in Hand-Held Control Unit (HRC100 Series)

INSTALLING OPTIONAL WIRELESS REMOTE CONTROL - MODEL WRC (Electronic Ignition)

Installing and Activating the Remote Receiver

1. Open bottom louver and locate plug receptacle. Plug receptacle is located either on right or left side of cabinet.
2. The WRC model receiver does not require a battery. Receiver can be installed by first plugging short extension cord into fireplace receptacle. Then plug receiver unit into extension cord. Finally plug ignition module plug into receiver unit (see Figure 18).
3. Activate remote handset battery by removing insulating tab on back of handset (see Figure 19). Battery is included pre-installed.
4. Once battery is activated unit is ready to use.
5. Replace bottom louver panel.

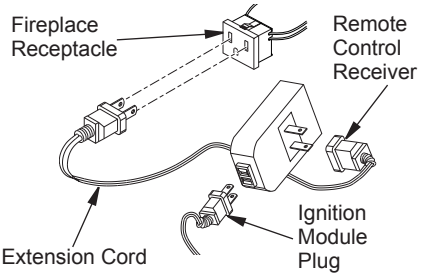

Figure 18 - Installing WRC Remote Receiver

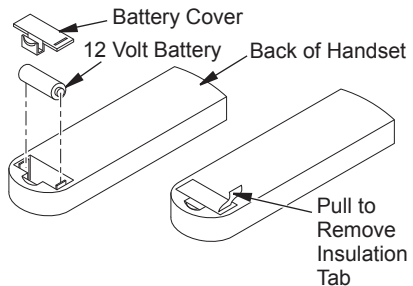

Figure 19 - Installing Battery into Back of Handset

INSTALLING OPTIONAL CONTROLS

Continued

WIRING DIAGRAMS

NOTICE: This appliance is equipped with a vent safety shutoff switch which will shut down the appliance in case of a venting problem. Do not bypass the vent safety shutoff switch. If the appliance should shut down, have a qualified installer, service agency, or your gas supplier inspect the vent before operating.

CAUTION: label all wires prior to disconnection when servicing controls. Wiring errors can cause improper and dangerous operation. Verify proper operation after servicing.

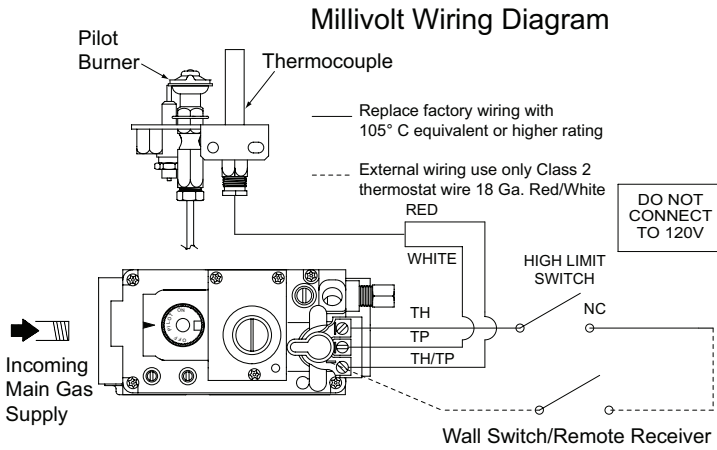

Figure 20 - Millivolt Ignition Wiring Diagram

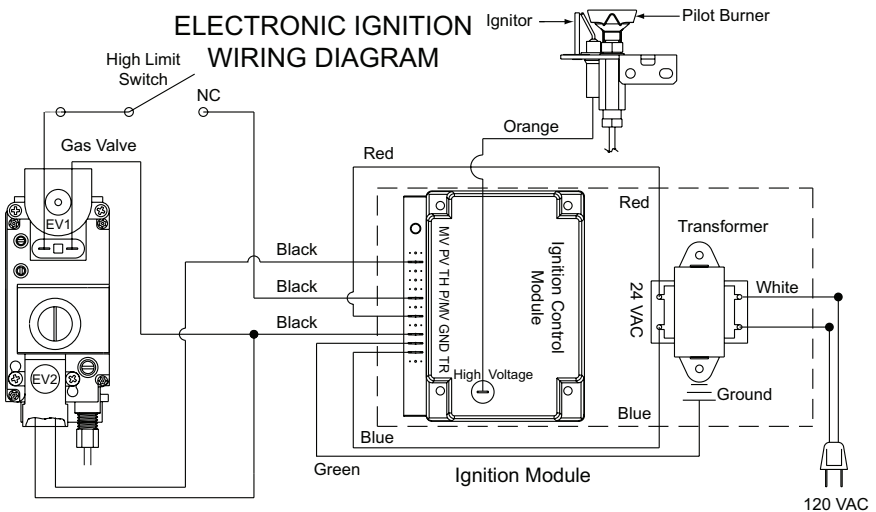

Figure 21 - Electronic Ignition Wiring Diagram

FIREPLACE INSTALLATION

CHECK GAS TYPE

Use only the correct type of gas (natural or propane/LP). If your gas supply is not the correct gas type, do not install fireplace. See dealer where you purchased your fireplace for proper gas type fireplace or to purchase gas conversion kit (see *Accessories*, page 31).

INSTALLING GAS PIPING TO FIREPLACE LOCATION

WARNING: A qualified service person must connect fireplace to gas supply. Follow all local codes.

CAUTION: For propane/LP units, never connect fireplace directly to the propane/LP supply. This heater requires an external regulator (not supplied). Install the external regulator between the fireplace and propane/LP supply.

Installation Items Needed

Before installing fireplace, make sure you have the items listed below.

- external regulator (supplied by installer)
- piping (check local codes)
- sealant (resistant to propane/LP gas)
- equipment shutoff valve *
- test gauge connection *
- sediment trap
- tee joint
- pipe wrench
- approved flexible gas line with gas connector (if allowed by local codes)

* A CSA design-certified equipment shutoff valve with 1/8" NPT tap is an acceptable alternative to test gauge connection. Purchase the CSA design-certified equipment shutoff valve from your retailer.

For propane/LP connection only, installer must supply an external regulator. External regulator will reduce incoming gas pressure. You must reduce incoming gas pressure to between 11" and 14" of water. If you do not reduce incoming gas pressure, fireplace external regulator damage could occur. Install external regulator with vent pointing down as shown in Figure 22. Pointing vent down protects it from freezing rain or sleet.

CAUTION: Use only new, black iron or steel pipe. Internally-tinned copper tubing may be used in certain areas. Check your local codes. Use pipe of 1/2" diameter or greater to allow proper gas volume to fireplace. If pipe is too small, undue loss of volume will occur.

Installation must include an equipment shutoff valve, union and plugged 1/8" NPT tap. Locate NPT tap within reach for test gauge hook up. NPT tap must be upstream from fireplace (see Figure 23).

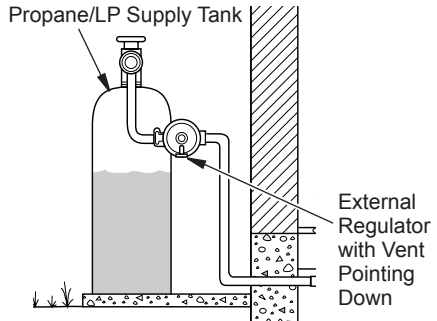

Figure 22 - External Regulator with Vent Pointing Down (Propane/LP Only)

CSA Design-Certified Equipment Shutoff Valve with 1/8" NPT Tap*

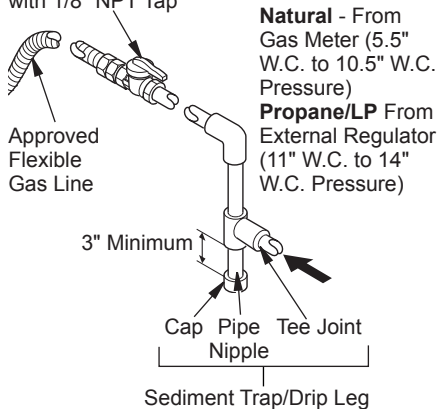

Figure 23 - Gas Connection

* The CSA design-certified equipment shutoff valve may be supplied with the appliance or you can purchase it from your retailer.

FIREPLACE INSTALLATION

Continued

IMPORTANT: Install main gas valve (equipment shutoff valve) in an accessible location. The main gas valve is for turning on or shutting off gas to appliance.

Check your building codes for any special requirements for locating equipment shutoff valve to fireplaces.

Apply pipe joint sealant lightly to male NPT threads. This will prevent excess sealant from going into pipe. Excess sealant in pipe could result in clogged fireplace valves.

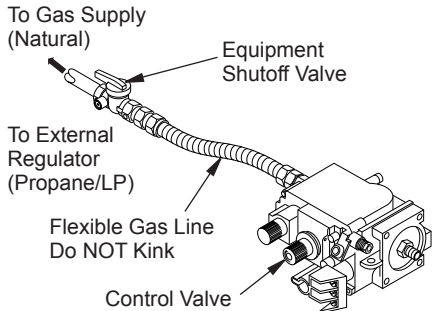

Figure 24 - Connecting Flexible Gas Line to Millivolt Valve

⚠ WARNING: Use pipe joint sealant that is resistant to liquid petroleum (LP) gas.

We recommend that you install a sediment trap/drip leg in supply line as shown in Figure 23, page 15. Locate sediment trap/drip leg where it is within reach for cleaning. Install in piping system between fuel supply and fireplace. Locate sediment trap/drip leg where trapped matter is not likely to freeze. A sediment trap traps moisture and contaminants. This keeps them from going into fireplace gas controls. If sediment trap/drip leg is not installed or is installed wrong, fireplace may not run properly.

CONNECTING FIREPLACE TO GAS SUPPLY

Installation Items Needed

- 3/4" and a 7/8" open end wrench or adjustable wrench
 - sealant (resistant to propane/LP gas, not provided)
1. Remove lower louver door panel by lifting up until disengaged. Swing forward and out of locating slots at bottom.
 2. Route flexible gas line (provided by installer) from equipment shutoff valve to fireplace. Route flexible gas supply line through one access hole on each side of fireplace cabinet.
 3. Attach flexible gas line from gas supply to the 1/2" flare fitting provided on control valve (see Figure 24).
 4. Check all gas connections for leaks (see [Checking Gas Connections](#)).

CHECKING GAS CONNECTIONS

⚠ WARNING: Test all gas piping and connections, internal and external to unit, for leaks after installing or servicing. Correct all leaks at once.

⚠ WARNING: Never use an open flame to check for a leak. Apply noncorrosive leak detection fluid to all joints. Bubbles forming show a leak. Correct all leaks at once.

PRESSURE TESTING GAS SUPPLY PIPING SYSTEM

Test Pressures In Excess Of 1/2 PSIG (3.5 kPa)

1. Disconnect fireplace and its individual equipment shutoff valve from gas supply piping system. Pressures in excess of 1/2 psig (3.5 kPa) will damage fireplace gas regulator.
2. Cap off open end of gas pipe where equipment shutoff valve was connected.
3. Pressurize supply piping system by either opening propane/LP supply tank valve for propane/LP gas fireplace or opening main gas valve located on or near gas meter for natural gas fireplace or using compressed air.
4. Check all joints of gas supply piping system. Apply noncorrosive leak detection fluid to all joints. Bubbles forming show a leak. Correct all leaks at once.
5. Reconnect fireplace and equipment shutoff valve to gas supply. Check reconnected fittings for leaks.

FIREPLACE INSTALLATION

Continued

Test Pressures Equal To or Less Than 1/2 PSIG (3.5 kPa)

1. Close equipment shutoff valve (see Figure 25).
2. Pressurize supply piping system by either opening propane/LP supply tank valve for propane/LP gas fireplace or opening main gas valve located on or near gas meter for natural gas fireplace or using compressed air.
3. Check all joints from propane/LP supply tank or gas meter to equipment shutoff valve (see Figure 26, for propane/LP or Figure 27, for natural gas). Apply noncorrosive leak detection fluid to all joints. Bubbles forming show a leak. Correct all leaks at once.

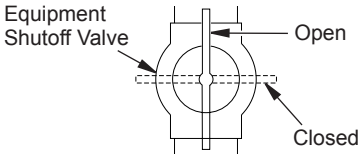

Figure 25 - Equipment Shutoff Valve

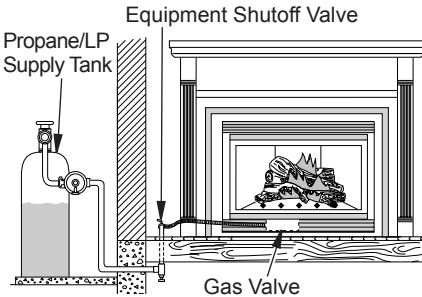

Figure 26 - Checking Gas Joints for Propane/LP Gas Fireplace

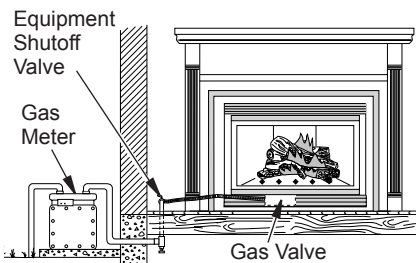

Figure 27 - Checking Gas Joints for Natural Gas Fireplace

PRESSURE TESTING FIREPLACE GAS CONNECTIONS

1. Open equipment shutoff valve (see Figure 25).
2. Open propane/LP supply tank valve for propane/LP fireplace or main gas valve located on or near gas meter for natural gas fireplace.
3. Make sure control knob of fireplace is in the OFF position.
4. Check all joints from equipment shutoff valve to gas valve (see Figure 26, for propane/LP or Figure 27, for natural gas). Apply noncorrosive leak detection fluid to all joints. Bubbles forming show a leak. Correct all leaks at once.
5. Light fireplace (see *Operating Fireplace*, page 20). Check all other internal joints for leaks.
6. Turn off fireplace (see *To Turn Off Gas to Appliance*, page 20 or 21 depending on your model).

LOUVER PANELS AND GLASS DOOR

CAUTION: Do not operate this fireplace with a broken glass door panel or without the glass door panel securely in place. For replacement part information see *Replacement Parts*, page 31.

CAUTION: Wear gloves and safety glasses while handling or removing broken glass. Do not remove if glass is hot. Keep children and pets away from glass.

WARNING: If fireplace has been running, turn off and unplug fireplace. Let cool before removing glass door or louvers.

FIREPLACE INSTALLATION

Continued

Removing Louver Panels

Remove top and bottom louver panels by simultaneously pulling both top end spring latches toward center of appliance until they are disengaged from locating holes (see Figure 28). Repeat for bottom spring latches and pull louvers outward. To install or replace items removed, simply reverse procedures above.

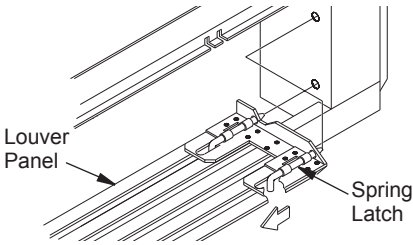

Figure 28 - Removing Louver Panel

Removing/Replacing Glass Door

WARNING: Handle glass door panel with care. Do not strike, slam or otherwise abuse glass. Do not operate fireplace with glass door removed, cracked or broken.

If replacement of glass is necessary, the entire assembly, glass and frame, must be replaced. If glass is broken, wear gloves and tape remaining fragments onto frame.

1. Placing a screw driver or your finger tips into gap between lower glass panel rail and bottom face frame, lift glass door assembly until door pins clear locating holes in bottom face frame (see Figure 29).
2. Swing bottom glass panel assembly out until door pins on lower rail clear bottom face frame (see Figure 30).
3. Lower door down until upper door pins are free of locating holes in spring clips and place in a safe area.
4. Replace glass panel in reverse order by inserting top door pins into spring clips, lifting up at lower frame rail and locating bottom pins in holes on lower face frame.

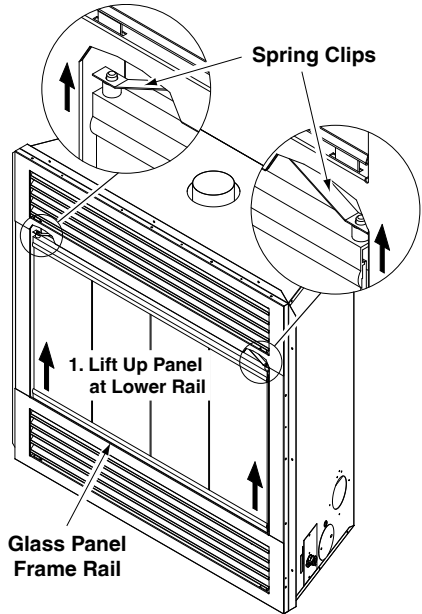

Figure 29 - Removing/Replacing Glass Door

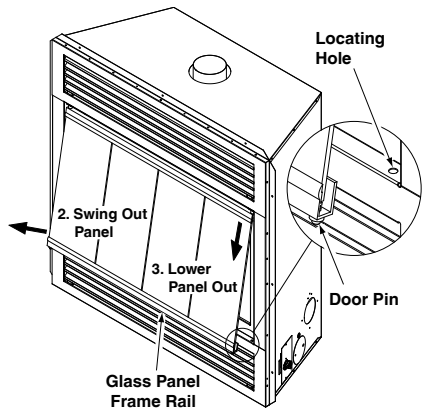

Figure 30 - Removing/Replacing Glass Door

FIREPLACE INSTALLATION

Continued

INSTALLING LOGS AND GLOWING EMBERS

A 4 piece ceramic log set comes packed inside the unit firebox. Removal of glass door is necessary to unpack and assemble logs and add hearth treatments. Follow steps under [Removing/Replacing Glass Door](#), page 18 to access logs and burner.

Assemble logs and add burner treatments as follows:

1. Position base log onto burner log mounts (see Figure 31).

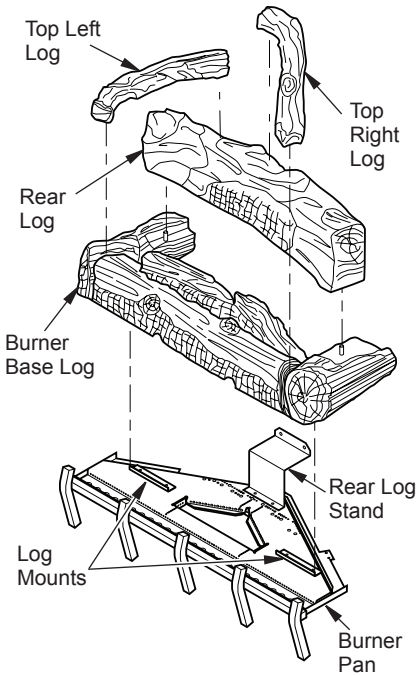

Figure 31 - Installing Logs

- Note: Cut out on bottom should fit over mounts and base log should be positioned against rear panel.*
2. Position holes on bottom of rear log over pins on base log (see Figure 31).
 3. Position top left log and top right log onto rear log and base log as shown in Figure 31.
 4. Break ember material into quarter sized pieces and place a single layer along the full length of ember tray to hide bottom edge of base log (see Figure 32).
 5. Replace glass door and louver panels (see [Removing/Replacing Glass Door](#), page 18).

⚠ WARNING: The glass door must be securely in place before running this fireplace. Do not run this fireplace if glass is missing or broken.

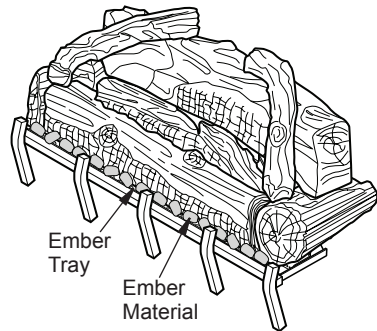

Figure 32 - Applying Ember Material

OPERATING FIREPLACE

MANUAL IGNITION SYSTEM

**FOR YOUR SAFETY
READ BEFORE LIGHTING**

⚠ WARNING: If you do not follow these instructions exactly, a fire or explosion may result causing property damage, personal injury or loss of life.

- A. This appliance is equipped with an ignition device which automatically lights the pilot. Do not light pilot by hand.
- B. **BEFORE LIGHTING** smell all around the appliance area for gas. Be sure to smell next to the floor because some gas is heavier than air and will settle on the floor.

WHAT TO DO IF YOU SMELL GAS

- Do not try to light any appliance.
 - Do not touch any electric switch; do not use any phone in your building.
 - Immediately call your gas supplier from a neighbor's phone. Follow the gas supplier's instructions.
 - If you cannot reach your gas supplier, call the fire department
- C. Use only your hand to push in or turn the gas control knob. Never use tools. If the knob will not push in or turn by hand, don't try to repair it, call a qualified service technician. Force or attempted repair may result in a fire or explosion.
 - D. Do not use this appliance if any part has been under water. Immediately call a qualified service technician to inspect the appliance and to replace any part of the control system and any gas control which has been under water.

LIGHTING INSTRUCTIONS

1. STOP! Read the safety information above.
2. Open lower louver panel.
3. Turn off all electric power to the fireplace.
4. Push in gas control knob slightly and turn clockwise ↻ to OFF (see Figure 33).
5. Wait five (5) minutes to clear out any gas. Then smell for gas, including near

the floor. If you smell gas, STOP! Follow "B" in the safety information above. If you don't smell gas go to the next step.

6. The pilot is located by the main burner and should not require accessing for lighting.
7. Turn gas control knob counterclockwise ↻ to PILOT.
8. Push in gas control knob all the way and hold. Immediately light the pilot by repeatedly pressing the piezo ignitor until a flame appears. Continue to hold for about one (1) minute after the pilot is lit. Release gas control knob and it will pop up. Pilot should remain lit. If it goes out, repeat steps 5 through 8.
 - If gas control knob does not pop up when released, stop and immediately call your service technician or gas supplier.
 - If the pilot will not stay lit after several tries, turn gas control knob to OFF and call your service technician or gas supplier.
9. Turn on all electric power to fireplace.
10. Turn gas control knob counterclockwise ↻ to ON.
11. To leave pilot lit and shut off burners only: turn control knob clockwise ↻ to the PILOT position. Set wall switch or remote selector switch to OFF position to prevent draining battery.
12. Close lower louver panel.

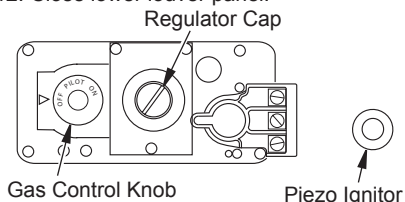

Figure 33 - Control Valve Millivolt

TO TURN OFF GAS TO APPLIANCE

1. Open lower louver panel.
2. Set the wall switch to "OFF" position or the HRC selector switch (when equipped) to prevent draining the battery.
3. Turn off all electric power to the appliance if service is to be performed.
4. Push in gas control knob slightly and turn clockwise ↻ to OFF.
5. Close lower louver panel.
6. Close equipment shutoff valve (see Figure 25, page 17).

OPERATING FIREPLACE



Continued

MANUAL LIGHTING PROCEDURE

1. Remove glass door (see *Removing/Replacing Glass Door*, page 18).
2. Follow steps 1 through 8 under *Lighting Instructions*, page 20).
3. Press gas control knob and light pilot with match.
4. Keep gas control knob pressed in for 30 seconds after lighting pilot. After 30 seconds, release gas control knob. Follow steps 10 through 11 under *Lighting Instructions*, page 20).
5. Replace glass door (see *Removing/Replacing Glass Door*, page 18).

ELECTRONIC IGNITION SYSTEM

LIGHTING INSTRUCTIONS

1. STOP! Read the safety information, page 20.
2. Turn off all electrical power to the fireplace.
3. Turn wall switch to the OFF position.
4. Open lower louver panel.
5. Turn equipment shutoff valve clockwise  to the OFF position (see Figure 34). Do not force.
6. Wait five (5) minutes to clear out any gas. Then smell for gas, including near the floor. If you smell gas, STOP! Follow "B" in the safety information, page 20. If you don't smell gas go to the next step.
7. Turn equipment shutoff valve counter-clockwise  to the ON position. Do not force.
8. Close lower louver panel.
9. Turn on all electric power to fireplace.
10. Turn wall switch to the ON position.

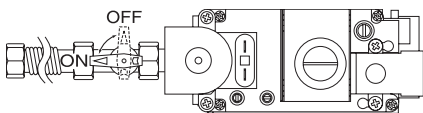



Figure 34 - Turning Equipment Shutoff Valve to the OFF Position

11. Visually locate pilot. Ignitor should begin to spark and main burner should ignite once flame appears at pilot.
 - If lighting appliance for the first time each season, it may take several attempts before supply gas can reach pilot and main burner.
 - If appliance will not stay lit after several attempts, follow instructions in *To Turn Off Gas To Appliance*, and call your service technician or gas supplier.

NOTICE: During initial operation of a new heater, the burning of residues from the manufacturing process of the firebox and logs will produce a paper-burning smell and orange flames. Open a window for the first few hours of operation to adequately vent this smell.

TO TURN OFF GAS TO APPLIANCE

1. Turn off wall switch.
2. Turn off all electric power to appliance if service is to be performed.
3. Open lower louver panel.
4. Turn equipment shutoff valve clockwise  to OFF. Do not force.
5. Close lower louver panel.

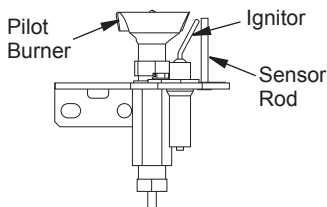

Figure 35 - Pilot

OPTIONAL WIRELESS REMOTE OPERATION

*Note: The WRC receiver and hand-held remote control kit must be purchased separately (see *Accessories*, page 31). Follow installation instructions included with the remote control.*

1. Turn equipment shutoff valve to ON position. You can now turn burner on and off with hand-held remote unit.

OPERATING FIREPLACE

Continued

IMPORTANT: Be sure to press the ON/OFF buttons on hand-held remote control unit for up to 3 seconds to assure proper operation.

2. Press ON/OFF button to turn the burner on and off.

OPTIONAL HAND-HELD REMOTE OPERATION

Note: All remote control accessories must be purchased separately (see [Accessories](#), page 31). Follow instructions included with the remote control.

NOTICE: You must light the pilot before using the hand-held remote control unit. See [Lighting Instructions](#), page 21.

After lighting, let pilot flame burn for about one minute. Turn control knob to ON position. Adjust flame adjustment knob anywhere between HI and LO. Slide the selector switch to the REMOTE position (see Figure 36).

Note: Burner may light if hand-held remote was on when selector switch was last turned off. You can now turn burner on and off with hand-held remote control unit.

IMPORTANT: Do not leave selector switch in the REMOTE or ON position when pilot is not lit. This will drain battery.

Blower Control Knob
(Optional Accessory)

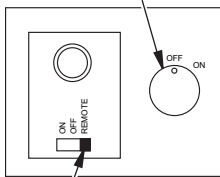

Selector Switch in Remote Position

Variable Control Knob

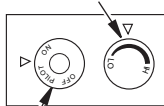

Gas Control Knob in ON Position

Figure 36 - Setting the Selector Switch, Gas Control Knob and Variable Control Knob for Remote Operation

ON/OFF SERIES MODEL HRC100

Hold control button on hand-held remote until burner turns on. Hold control button again until burner turns off (see Figure 37).

TO LOCK press both buttons on hand-held remote control until light stops flashing. Hand-held remote control is now locked. If fire is on it will be turned off automatically. In locked state, light will not light up when any button is pressed.

TO UNLOCK press both buttons together on hand-held remote control until light stops flashing. Hand-held remote is now unlocked.

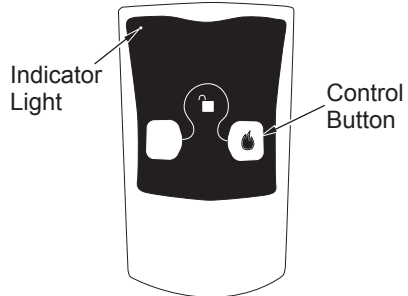

Figure 37 - On/Off Hand-Held Remote Control Unit HRC100

OPTIONAL GWMS2 ON/OFF WALL MOUNTED SWITCH

WARNING: Do not connect the appliance gas controls to a 120 VAC power source. Damage or injury may occur.

Light fireplace as instructed in [Lighting Instructions](#) on page 21. If using an HRC remote with a wall switch, set remote selector switch to the ON position (see Figure 36). Wall switch may now be used to turn burner flame ON and OFF.

To turn fireplace off, turn wall switch and/or remote selector switch to the OFF position and turn gas control knob back to PILOT. Pilot will remain lit.

IMPORTANT: To turn pilot off, turn gas control knob on heater to the OFF position.

INSPECTING BURNERS

Check pilot flame pattern and burner flame patterns often.

PILOT ASSEMBLY

The pilot assembly is factory preset for proper flame height. Alterations may have occurred during shipping and handling. Call a qualified service person to readjust the pilot if necessary.

The position and pattern of pilot flames in relation to sensing devices should be as shown in Figures 38 and 39 respectively.

Pilot flame may need adjustment in order for thermocouple, thermopile and/or ignition system to sense pilot flame.

If your pilot assembly does not meet these requirements:

- turn fireplace off (see [To Turn Off Gas to Appliance](#), page 20 or 21)
- see sections under [Troubleshooting](#), page 25

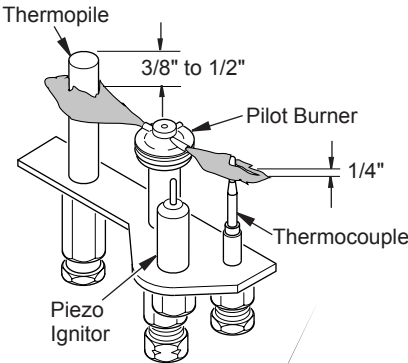

Figure 38 - Pilot Assembly (Millivolt Ignition System)

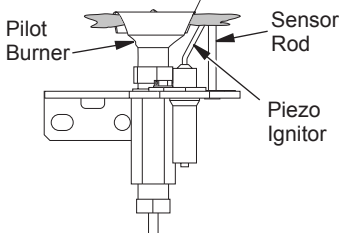

Figure 39 - Pilot Assembly Electronic Ignition System)

BURNER FLAME PATTERNS

Burner flames will be steady, not lifting or floating. Flame patterns will differ from unit to unit and will vary depending on installation type and weather conditions.

If vent configuration is installed incorrectly, flames will lift or "ghost". This can be dangerous. Inspect flames after installation to ensure proper installation and performance. Figure 40 shows a typical flame pattern.

If burner flame pattern differs from that described:

- turn fireplace off (see [To Turn Off Gas to Appliance](#), page 20 or 21)
- see [Troubleshooting](#), page 25

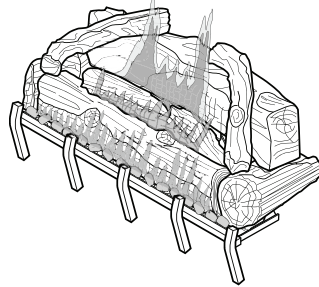

Figure 40 - Typical Flame Pattern

AIR ADJUSTMENT SETTING

The main burner air shutter opening is factory set to the following:

Natural Gas - 1/8", Propane/LP Gas - 3/4"

Air shutter may require adjustment depending on altitude, venting condition, burner operation and general flame appearance.

If flames are lifting or sooting shutter may require opening. If flames are too blue or improperly lighting shutter may require closing. See Figure 41 for proper air adjustment.

IMPORTANT: Do not reduce air shutter opening any lower than designed minimum stop setting of 1/8".

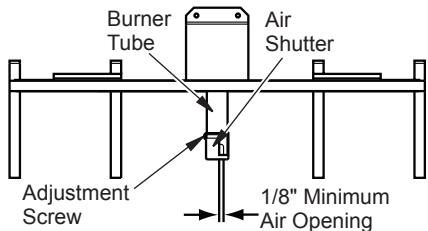

Figure 41 - Adjusting Air Setting

CLEANING AND MAINTENANCE

⚠ WARNING: Turn off fireplace and let cool before cleaning.

⚠ CAUTION: You must keep control areas, burners, and circulating air passages of fireplace clean. Inspect these areas of fireplace before each use. Have fireplace inspected yearly by a qualified service person. Fireplace may need more frequent cleaning due to excessive lint from carpeting, bedding material, pet hair, etc.

GLASS DOOR

⚠ WARNING: Handle glass door panel with care. Do not strike, slam, or otherwise abuse glass. Do not operate fireplace with the glass door removed, cracked, or broken.

⚠ WARNING: Do not use abrasive cleaners as this may damage glass. Use a nonabrasive household glass cleaner to clean glass. Do not clean glass when hot.

Glass must be cleaned periodically. During start-up it is normal for condensation to form on the inside of the glass causing lint, dust, and other airborne particles to cling to the glass surface. During initial start-up a slight film may form on the glass due to paint curing. The glass should be cleaned several times with a non-ammonia, non-abrasive household cleaner and warm water after the first two weeks of operation. Thereafter, clean the glass two or three times during each heating season, depending on the usage and circumstances present. Refer to [Removing/Replacing Glass Door](#), page 18, when removing glass door for cleaning.

⚠ WARNING: Only parts supplied by the manufacturer should be used when replacing broken or damaged glass door panel (see [Replacement Parts](#), page 31). This glass door panel is a complete unit. No substitute materials may be used.

⚠ CAUTION: Wear gloves and safety glasses while handling or removing broken glass. Do not remove if glass is hot. Keep children and pets away from glass.

If glass has been broken, carefully remove glass door (see [Removing/Replacing Glass Door](#), page 18). Vacuum all glass pieces with a shop vac.

⚠ CAUTION: Do not vacuum if pieces are hot.

Use only the tempered glass door replacement intended for this fireplace (see [Replacement Parts](#), page 31 for detail on ordering). No substitutions may be made. See [Removing/Replacing Glass Door](#), page 18 for instructions for replacing glass door.

⚠ WARNING: Do not block required air openings around glass or louver panels. Ventilated compartments should be inspected and vacuumed at least once a year to prevent blockage prior to operation.

PILOT AND BURNERS

- Remove ember material before cleaning burners and replace
- Burner and controls should be cleaned with compressed air to remove dust, dirt or lint.
- Use a vacuum cleaner or small, soft bristled brush to remove excess dust, dirt or lint.

CLEANING AND MAINTENANCE

Continued

LOGS

- If you remove logs for cleaning, refer to *Installing Logs and Glowing Embers*, page 19, to properly replace logs.
- Use a vacuum cleaner to remove any carbon buildup on logs.
- Replace log(s) if broken. See *Replacement Parts*, page 31.
- Replace ember material periodically as needed. See *Replacement Parts*, page 31.

VENTING SYSTEM

Conduct annual inspection of the venting system following these guidelines:

1. Check areas of venting system that are exposed to the weather corrosion (rust

- spots or streaks and in extreme cases, holes). Have these items replaced immediately by a qualified service person.
2. Remove the vent cap and shine a flashlight into vent. Remove any foreign material.
3. Check for evidence of excessive condensation. Continuous condensation can cause corrosion of caps, pipes and fittings and can be caused by having excessive lateral runs, too many elbows or exterior portions of the system being exposed to cold weather.
4. Inspect joints to verify that no pipe section or fitting has been distributed and loosened. Check mechanical supports such as wall straps for rigidity.

SPECIFICATIONS

(V)CB36N

- Maximum Input Rating: 18,000 Btu/hr
- Gas Type: Natural
- Orifice Size (Main Burner): #45 DMS (0.082")
- Ignition: Millivolt
- Manifold Pressure: 3.5" w.c. (0.87 kPa)
- Min. Inlet Supply Pressure: 5.5" w.c. (1.1 kPa)

(V)CB36P

- Maximum Input Rating: 18,000 Btu/hr
- Gas Type: Propane/LP
- Orifice Size (Main Burner): #55 DMS (0.052")
- Ignition: Millivolt
- Manifold Pressure: 10" w.c. (2.5 kPa)
- Min. Inlet Supply Pressure: 11" w.c. (2.7 kPa)

(V)CB36NE

- Maximum Input Rating: 18,000 Btu/hr
- Gas Type: Natural
- Orifice Size (Main Burner): #45 DMS (0.082")
- Ignition: Electronic
- Manifold Pressure: 3.5" w.c. (0.87 kPa)
- Min. Inlet Supply Pressure: 5.5" w.c. (1.1 kPa)

(V)CB36PE

- Maximum Input Rating: 18,000 Btu/hr
- Gas Type: Propane/LP
- Orifice Size (Main Burner): #55 DMS (0.052")
- Ignition: Electronic
- Manifold Pressure: 10" w.c. (2.5 kPa)
- Min. Inlet Supply Pressure: 11" w.c. (2.7 kPa)

ALL MODELS

- Fireplace Dimension HxWxD (Actual size of firebox measurements do not include nailing flanges or standoffs): 35.75" x 36.25" x 14.75" (90.8 x 92.1 x 37.5 cm)
- Carton Dimension HxWxD: 36.75" x 38" x 16.25" (93.3 x 96.5 x 41.3 cm)

SERVICE HINTS

When Gas Pressure Is Too Low

- pilot will not stay lit
- burners will have delayed ignition
- heater will not produce specified heat
- for propane/LP units, propane/LP gas supply may be low

You may feel your gas pressure is too low. If so, contact your local natural or propane/LP gas supplier.

TECHNICAL SERVICES

You may have further questions about installation, operation, or troubleshooting. If so, contact DESA Heating, LLC at 1-866-672-6040. When calling please have your model and serial numbers of your heater ready.

You can also visit DESA Heating, LLC's web site at www.desatech.com.

TROUBLESHOOTING

 **WARNING:** Turn off heater and let cool before servicing. Only a qualified service person should service and repair heater.

 **CAUTION:** Never use a wire, needle or similar object to clean ODS/pilot. This can damage ODS/pilot unit.

Note: All troubleshooting items are listed in order of operation.

The two most common causes of a malfunctioning gas appliance are:

1. Loose wiring connections
2. Construction debris clogging the pilot and/or gas control valve filter

OBSERVED PROBLEM	POSSIBLE CAUSE	REMEDY
<i>Manual Ignition System Only</i> When ignitor button is pressed, there is no spark at ODS/pilot	<ol style="list-style-type: none">1. Ignitor electrode not connected to ignitor cable2. Ignitor cable pinched or wet3. Piezo ignitor nut is loose4. Broken ignitor cable5. Bad piezo ignitor6. Ignitor electrode positioned wrong7. Ignitor electrode broken	<ol style="list-style-type: none">1. Reconnect ignitor cable2. Free ignitor cable if pinched by any metal or tubing. Keep ignitor cable dry3. Tighten nut holding piezo ignitor to base panel of log set. Nut is located behind base panel.4. Replace ignitor cable5. Replace piezo ignitor6. Replace pilot assembly7. Replace pilot assembly
<i>Manual Ignition System Only</i> When ignitor button is pressed, there is spark at ODS/pilot but no ignition	<ol style="list-style-type: none">1. Gas supply turned off or equipment shutoff valve closed2. Control knob not in PILOT position3. Control knob not pressed in while in PILOT position4. Air in gas lines when installed5. Depleted gas supply (propane/LP only)6. ODS/pilot is clogged7. Gas regulator setting is not correct	<ol style="list-style-type: none">1. Turn on gas supply or open equipment shutoff valve2. Turn control knob to PILOT position3. Press in control knob while in PILOT position4. Continue holding down control knob. Repeat igniting operation until air is removed5. Contact local propane/LP gas company6. Clean ODS/pilot (see <i>Cleaning and Maintenance</i>, page 24) or replace ODS/pilot assembly7. Replace gas regulator

TROUBLESHOOTING

Continued

OBSERVED PROBLEM	POSSIBLE CAUSE	REMEDY
<i>Manual Ignition System Only</i> Pilot lights but flame goes out when control knob is released	<ol style="list-style-type: none">1. Gas control knob not fully pressed in2. Gas control knob not pressed in long enough3. Equipment shutoff valve not fully open4. Pilot flame not touching thermocouple, which allows thermocouple to cool, causing pilot to go out. This problem could be caused by one or more of the following: A) Low gas pressure B) Dirty or partially clogged pilot5. Thermocouple connection loose at control valve.6. Thermocouple damaged7. Control valve damaged	<ol style="list-style-type: none">1. Press in gas control knob fully2. After pilot lights, keep gas control knob pressed in 30 seconds3. Fully open equipment shutoff valve4. A) Contact local natural or propane/LP gas company B) Clean pilot (see <i>Cleaning and Maintenance</i>, page 24) or replace pilot assembly5. Hand tighten until snug, then tighten 1/4 turn more6. Replace pilot assembly7. Replace control valve
Burner does not light after pilot is lit or cycles during operation.	<ol style="list-style-type: none">1. Burner orifice clogged2. Inlet gas pressure is too low3. Thermopile leads disconnected or improperly connected4. Thermopile is defective5. Improper venting or excessive blockage	<ol style="list-style-type: none">1. Clean burner (see <i>Cleaning and Maintenance</i>, page 24) or replace burner orifice2. Contact local propane/LP or natural gas company3. Reconnect leads4. Replace thermopile5. Have the vent system inspected, including the termination cap. Remove any restriction or obstruction
Delayed ignition at burner	<ol style="list-style-type: none">1. Manifold pressure too low2. Burner porting or orifice clogged	<ol style="list-style-type: none">1. Contact local propane/LP or natural gas company2. Clean burner (see <i>Cleaning and Maintenance</i>, page 24) or replace burner orifice
Burner backfiring during combustion	<ol style="list-style-type: none">1. Burner orifice is clogged or damaged2. Damaged burner3. Gas regulator defective	<ol style="list-style-type: none">1. Clean burner (see <i>Cleaning and Maintenance</i>, page 24) or replace burner orifice2. Replace damaged burner3. Replace gas control
Slight smoke or odor during initial operation	<ol style="list-style-type: none">1. Residues from manufacturing processes and logs curing	<ol style="list-style-type: none">1. Problem will stop after a few hours of operation

TROUBLESHOOTING

Continued

OBSERVED PROBLEM	POSSIBLE CAUSE	REMEDY
Heat produces a whistling noise when burner is lit	<ol style="list-style-type: none">1. Turning gas control knob to HI position when burner is cold2. Air in gas line3. Dirty or partially clogged burner orifice	<ol style="list-style-type: none">1. Turn gas control knob to LO position and let warm up for a minute2. Operate burner until air is removed from line. Have gas line checked by propane/LP or natural gas company3. Clean burner (see <i>Cleaning and Maintenance</i>, page 24) or replace burner orifice
Glass soots	<ol style="list-style-type: none">1. Flame impingement on logs2. Debris around burner air mixer	<ol style="list-style-type: none">1. Adjust the log set so the flame does equipment shut-off valve2. Inspect the opening at the base of the burner to see that it is not packed with any type of material
Fireplace produces a clicking/ticking noise just after burners are lit or shut off	<ol style="list-style-type: none">1. Metal expanding while heating or contracting while cooling	<ol style="list-style-type: none">1. This is normal. If noise is excessive, contact qualified service person
Remote does not function	<ol style="list-style-type: none">1. Battery is not installed or battery is power is low	<ol style="list-style-type: none">1. Replace 9-volt batteries in receiver and remote control
Fireplace shuts off in use. Burner backfiring during combustion	<ol style="list-style-type: none">1. High or gusting winds2. Low line pressure3. Pilot is partially clogged4. Improper or restricted venting5. Clogged burner tube, blocked orifice or improper burner air adjustment6. Bad thermopile or thermocouple7. Vent cap improperly installed or blocked	<ol style="list-style-type: none">1. Fireplace has been tested for up to 40 mph winds. However, extreme conditions may occur. See <i>Lighting Instructions</i>, page 20 or 212. Check local propane/LP or natural gas company3. Clean pilot (see <i>Cleaning and Maintenance</i>, page 24)4. Locate and correct all vent conditions (see <i>Checking for Proper Venting</i>, page 10)5. Clean burner tube and orifice, adjust air shutter (see <i>Inspecting Burners</i>, page 23)6. Replace faulty components7. Check for proper installation or remove debris or blockage

TROUBLESHOOTING

Continued

OBSERVED PROBLEM	POSSIBLE CAUSE	REMEDY
<i>Electronic Ignition Models</i> Only Ignitor will not spark or pilot will not light	1. No gas supply, or shutoff valve is OFF	1. Check to see if you have gas supply and that equipment shutoff valve is opened
	2. Air in gas line	2. Repeat lighting procedure several times to purge all air out of lines. If after repeated attempts appliance does not light, call for qualified service and repair
	3. Construction debris clogging pilot orifice	3. Remove debris and dirt, and inspect and clean any other possible obstructions
	4. Low gas pressure	4. Contact your gas supplier to check pressure
	5. Kinked pilot line	5. Have a qualified technician replace pilot line
	6. Control valve is not opening	6. Replace control valve (Refer to <i>Replacement Parts</i> , page 31)
	7. No power to unit or the ignition module	7. Check that main power is on and that wire connections are made correctly to the ignition model (see <i>Wiring Diagrams</i> , page 13). Check for 24 VAC at the secondary side of the transformer. If 24 VAC is present, and the module does not operate, have the module replaced otherwise have the transformer replaced
<i>Electronic Ignition Models</i> Only Pilot will not stay lit	1. Loose wiring on ignitor wire to ignition module and/or poor ground to ignition module	1. Check wiring connection. Refer to wiring diagram (see <i>Wiring Diagrams</i> , page 13) and/or check ground wire to ignition module
	2. Pilot flame too low to sense	2. Clean and adjust pilot burner and check gas supply and inlet pressure to unit. <i>Note:</i> Have a qualified technician replace pilot assembly if broken or corroded
<i>Electronic Ignition Models</i> Only Frequent outage of main burner and pilot after complete ignition sequence	1. Pilot flame may be too low to sense flame causing ignition module to shut down	1. Clean and adjust pilot flame for maximum flame across sensor rod
	2. Improper or restricted venting	2. Locate and correct all vent conditions (see <i>Checking for Proper Venting</i> , page 10)

TROUBLESHOOTING

Continued



WARNING: If you smell gas

- Shut off gas supply.
- Do not try to light any appliance.
- Do not touch any electrical switch; do not use any phone in your building.
- Immediately call your gas supplier from a neighbor's phone. Follow the gas supplier's instructions.
- If you cannot reach your gas supplier, call the fire department.

IMPORTANT: Operating heater where impurities in air exist may create odors. Cleaning supplies, paint, paint remover, cigarette smoke, cements and glues, new carpet or textiles, etc., create fumes. These fumes may mix with combustion air and create odors. These odors will disappear over time.

OBSERVED PROBLEM	POSSIBLE CAUSE	REMEDY
Fireplace produces unwanted odors	1. Gas leak. See Warning statement above	1. Locate and correct all leaks (see <u>Checking Gas Connections</u> , page 16)
Gas odor when control knob is in OFF position or during combustion	1. Gas leak. See Warning statement above 2. Control valve defective	1. Locate and correct all leaks (see <u>Checking Gas Connections</u> , page 16) 2. Replace gas control valve
Dark residue on logs or inside of fireplace	1. Improper log placement 2. Air holes at burner inlet blocked 3. Burner flame holes blocked 4. Improper venting or excessive blockage 5. Excessive amounts of embers and pan material	1. Properly locate logs (see <u>Installing Logs, Lava Rock and Glowing Embers</u> , page 19) 2. Clean out air holes at burner inlets. Periodically repeat as needed 3. Remove blockage or replace burner 4. Have the vent system inspected, including the termination cap. Remove any restrictions or blockage 5. Clear excess embers from around rear main ports. Use a minimum one layer of smaller ember pieces to achieve best glowing effect over visible areas

REPLACEMENT PARTS

Note: Use only original replacement parts. This will protect your warranty coverage for parts replaced under warranty.

PARTS UNDER WARRANTY

Contact authorized dealers of this product. If they can't supply original replacement part(s), call DESA Heating, LLC at 1-866-672-6040.

When calling DESA Heating, LLC have ready

- your name and address
- model and serial numbers of your heater
- how heater was malfunctioning
- type of gas (propane/LP or natural gas)
- purchase date

Usually, we will ask you to return the part to the factory.

PARTS NOT UNDER WARRANTY

Contact authorized dealers of this product. If they can't supply original replacement part(s), call DESA Heating, LLC at 1-866-672-6040 for referral information. A list of authorized dealers can be found by visiting www.desatech.com.

When calling DESA Heating, LLC, have ready

- model number of your heater
- the replacement part number

ACCESSORIES

NOTE: All accessories may not be available for all fireplace models.

Purchase these fireplace accessories from your local retailer. If they can not supply these accessories, call DESA Heating, LLC at 1-866-672-6040, for information. You can also write to the address listed on the back of this manual

FLEXIBLE GAS LINE CONNECTOR CIK

For all models.

PROPANE/NATURAL GAS CONVERSION KIT

PCBM-36C - Propane/LP Gas Millivolt Models

NCBM-36C - Natural Gas Millivolt Models

PCBE-36C - Propane/LP Gas Electronic Models

NCBE-36C - Natural Gas Electronic Models

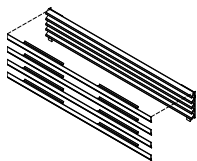

ROLLED LOUVER TRIM KITS

LTC36B - Brushed Brass

LTC36P - Platinum

FACE MANTELS

FM36AP - 36" primed, Traditional

FM36AU - 36" unfinished, Traditional

FM36AO - 36" oak stained, Traditional

FM36BP - 36" primed, Federal

FM36BU - 36" unfinished, Federal

FM36BO - 36" oak stained, Federal

FM36CP - 36" primed, Classic

FM36CU - 36" unfinished, Classic

FM36CO - 36" oak stained, Classic

FM42BP - 42" primed, Federal

FM42BU - 42" unfinished, Federal

FM42BO - 42" oak stained, Federal

Face mantels frame your fireplace and can be installed around wood, gas or electric fireplaces.

RECEIVER AND HAND-HELD ON/OFF REMOTE CONTROL KIT - HRC100 SERIES

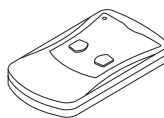

Allows the fireplace to be turned on and off conveniently with dual safety lock feature.

REMOTE CONTROL KIT WRC SERIES

Standard ON/OFF electronic remote control kit.

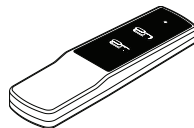

WALL MOUNTED ON/OFF SWITCH GWMS2

Allows burner system to be turned on and off with a wall switch.

PARTS

FIREPLACE ASSEMBLY FOR MODELS (V)CB36N, (V)CB36P, (V)CB36NE AND (V)CB36PE

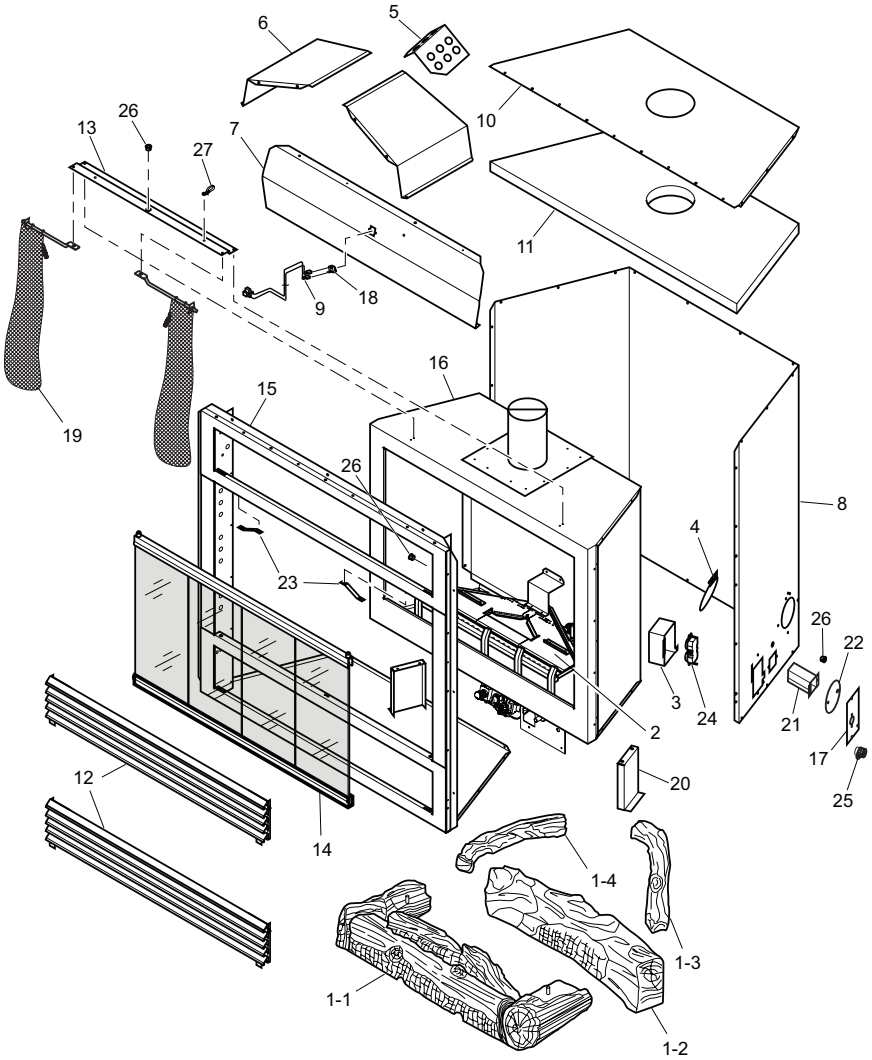

PARTS

This list contains replaceable parts used in your fireplace. When ordering parts, follow the instructions listed under Replacement Parts on page 31 of this manual.

KEY NO.	PART NO.	DESCRIPTION					QTY.
			(V)CB36N	(V)CB36P	(V)CB36NE	(V)CB36PE	
1	116108-01	Log Set	•	•	•	•	1
1-1	116109-01	Burner Base Log	•	•	•	•	1
1-2	116110-01	Rear Log	•	•	•	•	1
1-3	111802-05	Right Top Log	•	•	•	•	1
1-4	111802-04	Left Top Log	•	•	•	•	1
2	117447-01	Burner Assembly Complete (See pages 30 and 32)	•	•	•	•	1
3	114889-01	Junction Box Duplex Plug			•	•	1
4	106967-01	Damper Assembly	•	•	•	•	1
5	117461-01	Vent Baffle	•	•	•	•	1
6	117456-01	Diverter Panel	•	•	•	•	2
7	117455-01	Heat Deflector	•	•	•	•	1
8	114875-02	Fireplace Surround	•	•	•	•	1
9	117450-01	Wire Harness Assembly	•	•	•	•	1
10	117451-01	Fireplace Top	•	•	•	•	1
11	117452-01	Fireplace Top Insulation	•	•	•	•	1
12	117445-01	Louver Assembly	•	•	•	•	2
13	117458-01	Hanger Bracket	•	•	•	•	1
14	117446-01	Glass Door Assembly	•	•	•	•	1
15	**	Face Assembly	•	•	•	•	1
16	**	Firebox Assembly (see pages 32 and 33 for details)	•	•	•	•	1
17	110973-01	Cover Junction Box	•	•	•	•	2
18	106543-01	High Limit Switch	•	•	•	•	1
19	26782	Screen Assembly	•	•	•	•	2
20	26290	Firebox Leg	•	•	•	•	2
21	24460	Gas Conduit Assembly	•	•	•	•	2
22	21171	Gas Knock-Out Cover	•	•	•	•	2
23	20090	Spring Clip	•	•	•	•	2
24	14418	Duplex Plug Receptacle			•	•	1
25	14123	Bushing Universal Strain Relief			•	•	1
26	11408	Bushing 0.5" Electric	•	•	•	•	3
27	11404	Cable Tie Down	•	•	•	•	1
PARTS AVAILABLE - NOT SHOWN							
	25580	Ember Bag	•	•	•	•	1
	27253	Notice Label	•	•	•	•	1
	117700-01	Wiring Diagram Label	•	•			1
	117701-01	Wiring Diagram Label			•	•	1

** Not a field replaceable part.

PARTS

BURNER ASSEMBLY FOR MODELS (V)CB36N (V)CB36P, (V)CB36NE AND (V)CB36PE

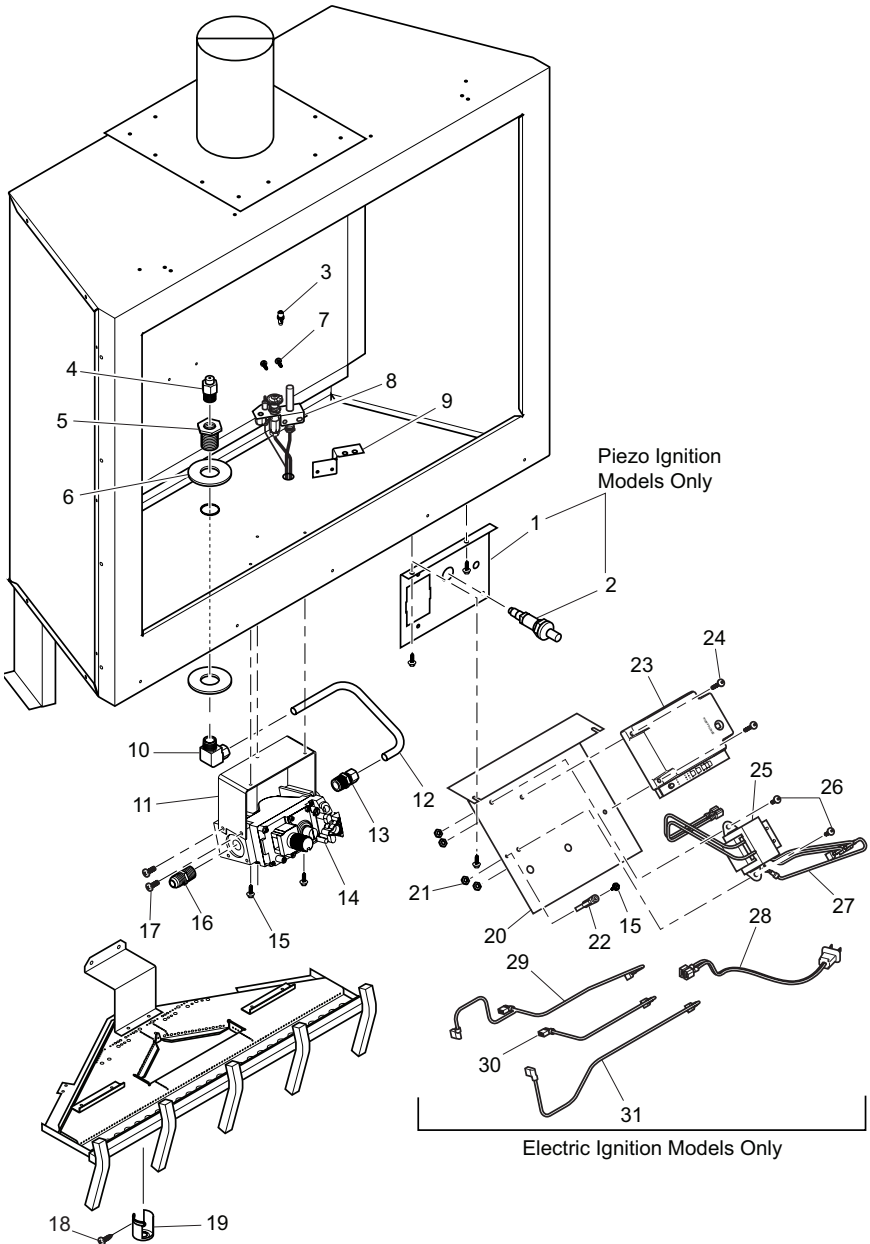

PARTS

This list contains replaceable parts used in your fireplace. When ordering parts, follow the instructions listed under Replacement Parts on page 31 of this manual.

KEY NO.	DESCRIPTION					QTY.
		(V)CB36N	(V)CB36P	(V)CB36NE	(V)CB36PE	
1	116317-01 Remote Ignitor Bracket	•	•			1
2	102445-01 Ignitor Piezo	•	•			1
3	108085-01 Pilot Orifice #51(Natural Gas)	•				1
	108085-02 Pilot Orifice #30 (Propane/LP Gas)		•			1
	108867-01 Pilot Orifice BL14LP (Propane/LP Gas)			•		1
	108867-02 Pilot Orifice BL22N (Natural Gas)			•		1
4	117702-01 Burner Orifice #45 (Natural Gas)	•	•	•		1
	26482 Burner Orifice #55 (Propane/LP Gas)		•	•	•	1
5	11214 Fitting Bulkead w/ Nut Brass	•	•	•	•	1
6	11226 Washer, Flat 7/8" ID x 2" OD x 1/8" Thick	•	•	•	•	2
7	11102 Screw, #8 x 3/8" PPH F Zinc.	•	•	•	•	2
8	117507-01 Pilot Assembly (Natural Gas)	•				1
	117507-02 Pilot Assembly (Propane/LP Gas)		•			1
	108866-01 Pilot Assembly PSE (Natural Gas)			•		1
	108866-02 Pilot Assembly PSE (Propane/LP Gas)				•	1
9	24360 Pilot Bracket	•	•	•	•	1
10	14399 Fitting Brass Elbow 3/8" MPT x 3/8" Comp. Tube	•	•	•	•	1
11	26808 Valve Bracket	•	•	•	•	1
12	24389 Tube 3/8" Dia. x 11" Aluminum	•	•	•	•	1
13	14396 Fitting Brass Straight 3/8" MPT x 3/8" Comp. Tube	•	•	•	•	1
14	14512 Gas Control Valve Millivolt (Natural Gas)	•				1
	14513 Gas Control Valve Millivolt (Propane/LP Gas)		•			1
	14569 Gas Control Valve Electric (Natural Gas)			•		1
	14570 Gas Control Valve Electric (Propane/LP Gas)				•	1
15	11105 Screw, #10 x 1/2" HWH LGM Zinc	•	•	•	•	11
16	14500 Fitting 3/8" MPT x 1/2" Flare	•	•	•	•	1
17	11107 Screw, #10-32 x 1/4" PPH Zinc	•	•	•	•	4
18	11187 Screw, #8 x 1/4" PPH	•	•	•	•	1
19	14299 Air Shutter	•	•	•	•	1
20	116316-01 Ignition Module Bracket			•		1
21	11201 Nut, #8-32 Hex Zinc			•	•	4
22	11404 Cable, Tie 8.5" #10 Screwdown			•	•	1
23	110286-01 Ignition Module Syntek			•	•	1
24	11186 Screw, #8-32 x 1" PPH			•	•	2
25	14129 Transformer, 24V Class 2			•	•	1
26	11109 Screw, #8-32 x 1/2" PPH			•	•	2
27	111059-03 Ground Wire Harness			•	•	1
28	108863-01 Plug 24" Supply Connect			•	•	1
29	116719-01 Gas Valve Wire Harness (MV/PV)			•	•	1
30	116719-02 Gas Valve Wire Harness (MV)			•	•	1
31	116719-03 Gas Valve Wire Harness (PV)			•	•	1

WARRANTY

KEEP THIS WARRANTY

Model _____
(located on product or identification tag)

Serial No. _____
(located on product or identification tag)

Date Purchased _____

Keep receipt for warranty verification.

Always specify model and serial numbers when communicating with the factory.

The only warranty applicable is our standard written warranty. We make no other warranty, expressed or implied.

LIMITED WARRANTY B-VENT FIREPLACE

DESA Heating, LLC warrants this product to be free from defects in materials and components for four (4) years from the date of first purchase, provided that the product has been properly installed, operated and maintained in accordance with all applicable instructions. To make a claim under this warranty the Bill of Sale must be presented.

This warranty is extended only to the original retail purchaser. This warranty covers the cost of part(s) required to restore this heater to proper operating condition and an allowance for labor when provided by a DESA Heating, LLC Authorized Service Center. Warranty part(s) MUST be obtained through authorized dealers of this product and/or DESA Heating, LLC who will provide original factory replacement parts. Failure to use original factory replacement parts voids this warranty. The product MUST be installed by a qualified installer in accordance with all local codes and instructions furnished with the unit.

This warranty does not apply to parts that are not in original condition because of normal wear and tear or parts that fail or become damaged as a result of misuse, accidents, lack of proper maintenance or defects caused by improper installation. Travel, diagnostic cost, labor, transportation and any and all such other costs related to repair will be the responsibility of the owner.

TO THE FULL EXTENT ALLOWED BY THE LAW OF THE JURISDICTION THAT GOVERNS THE SALE OF THE PRODUCT; THIS EXPRESS WARRANTY EXCLUDES ANY AND ALL OTHER EXPRESSED WARRANTIES AND LIMITS THE DURATION OF ANY AND ALL IMPLIED WARRANTIES, INCLUDING WARRANTIES OF MERCHANTABILITY AND FITNESS FOR A PARTICULAR PURPOSE TO FOUR (4) YEARS ON ALL COMPONENTS FROM THE DATE OF FIRST PURCHASE; AND DESA HEATING, LLC'S LIABILITY IS HEREBY LIMITED TO THE PURCHASE PRICE OF THE PRODUCT AND DESA HEATING, LLC SHALL NOT BE LIABLE FOR ANY OTHER DAMAGES WHATSOEVER INCLUDING INDIRECT, INCIDENTAL OR CONSEQUENTIAL DAMAGES.

Some states do not allow a limitation on how long an implied warranty lasts or an exclusion or limitation of incidental or consequential damages, so the above limitation on implied warranties or exclusion or limitation on damages may not apply to you.

This warranty gives you specific legal rights and you may also have other rights that vary from state to state.

For information about this warranty write:



DESA Heating, LLC
2701 Industrial Drive
P.O. Box 90004
Bowling Green, KY 42102-9004
www.desatech.com



117437 01
NOT A UPC

117437-01
Rev D
07/07