

Detex Corporation, 302 Detex Drive, New Braunfels, Texas 78130-3045
 (830)629-2900 / 1-800-729-3839 / Fax (830)620-6711
 E-MAIL: detex@detex.com INTERNET: www.detex.com

INSTALLATION INSTRUCTIONS FOR ADVANTEX MORTISE LOCK 30 & F30 SERIES DEVICE & "W" (Weatherized) MODELS



MORTISE LOCK and DEVICE INSTALLATION INSTRUCTIONS (30 and F30 Series)

Dwg #: 103200 (SS)
 104695 (AL)

*Fillerplate subassembly P/Ns:
 100860-X (LD/HD/CD/EA/ES/EX/ED/ER)
 105034-X (CD Dogging EE Mortise)

EC1 Endcap P/N: 101642-X (shown)
 EC2 Endcap (S.S.) P/N: 104304-X
 EC2 Endcap (AL) P/N: 104612-X

Centercase cover
 S.S. P/N: 102353-X
 AL P/N: 104601-X

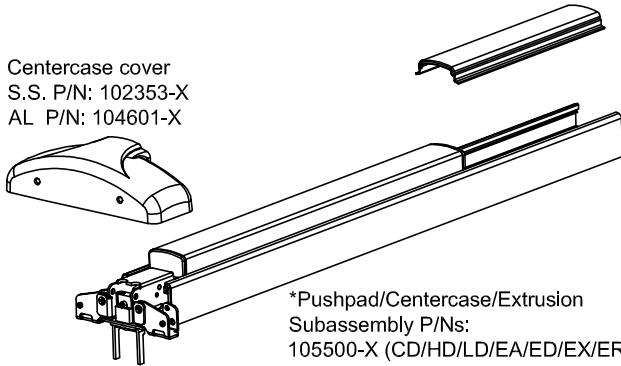

Endcap bracket
 EC1: P/N 100147 (shown)
 EC2: P/N 104303

*Pushpad/Centercase/Extrusion
 Subassembly P/Ns:
 105500-X (CD/HD/LD/EA/ED/EX/ER/EE)

*Note: Specify finish, length, and operations when ordering

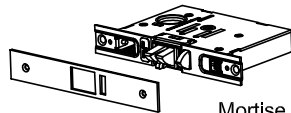

Front Plate P/N:
 103203-X

Mortise lock P/Ns:
 103320-1 (Standard)
 103320-2 (EE)

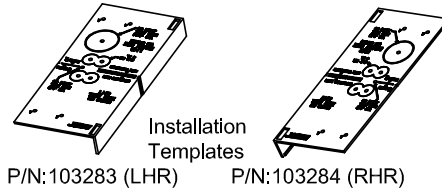

Installation
 Templates
 P/N:103283 (LHR) P/N:103284 (RHR)

MORTISE CYLINDER INSTALLATION (CD, EA and EE only)

STRIKES			
Model No.	Depiction	Part No.	Description
90		103285-X	ANSI strike
OPTIONAL STRIKES			
91		103294-X	ANSI flat lip strike
92		103286-X	Double door short open back strike
93		103289-X	Double door long open back strike

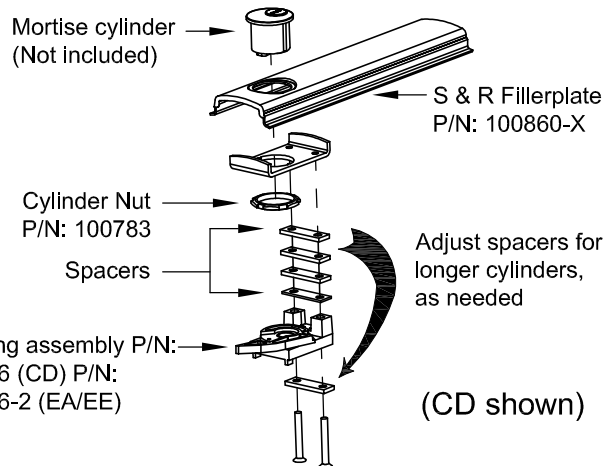

Machine Screws					
A	B	D	E	H	I
1/4-20 x 1" Drill Size: #7 or Ø13/64"	1/4-20 x 1/4"	#6-32 x 3/8"	#10-32 x 5/16"	#8-32 x 1/2"	#12-24 x 1/2"
Sheet Metal / Wood Screws			Self-Drilling Screw		
F	J	K			
#14 x 1-1/4" Drill Size: Ø3/16 for wood	#12 x 1"	#14 x 1-1/2"			

STEPS 1-2:
INSTALL MORTISE LOCK
(Note: LHR installation shown)

1 Use plastic template to mark and drill mortise lock and backplate holes

Door prepared to ANSI A115.13
See T2000 (metal) and
T2001 (wood) templates

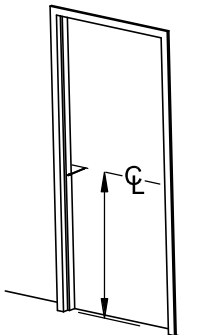

Mark centerline for device
40" above finished floor

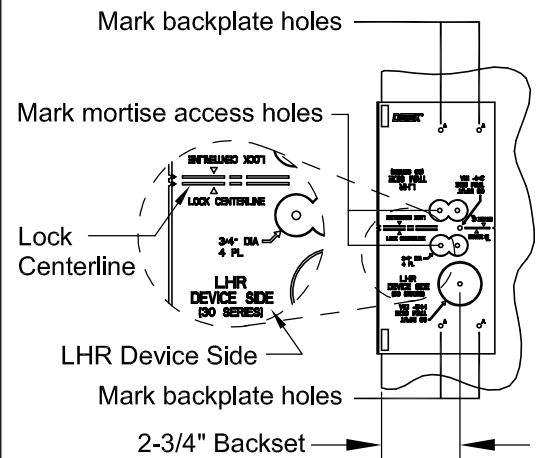
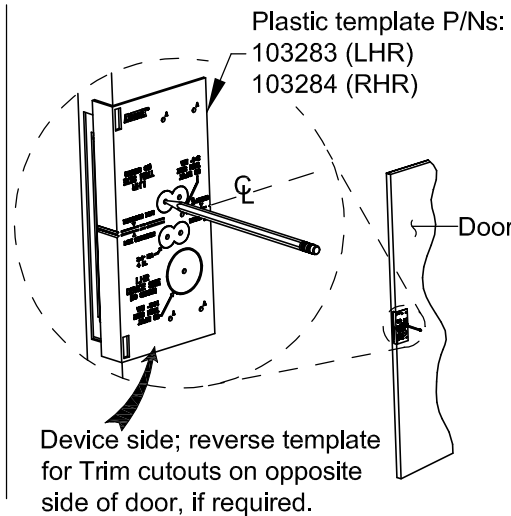

NOTES:

- 1) File sharp corners to complete slots where needed.
- 2) See Trim instructions where applicable for drilling trim holes.
- 3) See electrical instructions for wiring electrical devices.

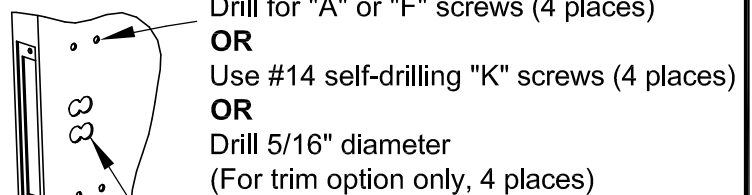

If Outside Key Control (OKC) is required, see OKC step on last page before continuing to step 2

AND
3/4" diameter 4 places

2 Install mortise lock

Install lock with (2) "I" screws or
(2) "J" screws for wood doors

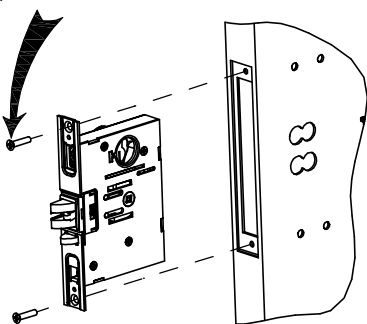

To change lock HANDING:
Remove block and rotate latchbolt

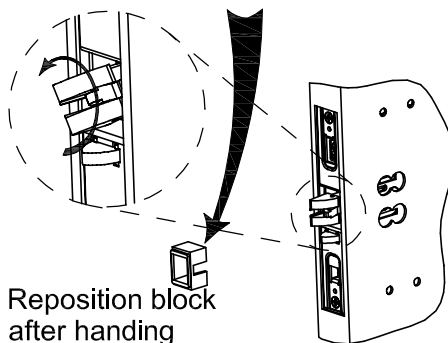

Reposition block
after handing

Install plate with (2) "H" screws

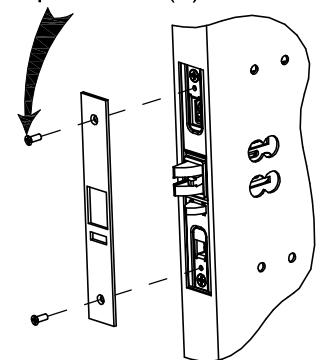

STEP 3: INSTALL BACKPLATE

3 Install backplate & trim for outside key control

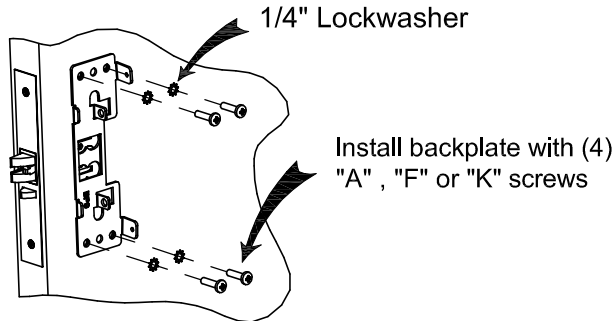

NOTE:

- (1) See Trim instructions where applicable
- (2) See last page for outside key control (03) function installation

STEP 4: INSTALL STRIKE

4 Install Strike

Install strike with (2) "I" screws

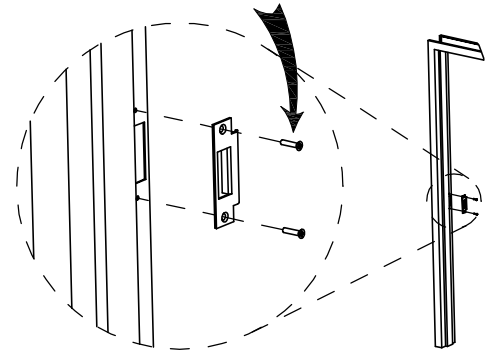

STEPS 5-7: INSTALL DEVICE

5 Install device to backplate

Align fingers with mortise lock in door

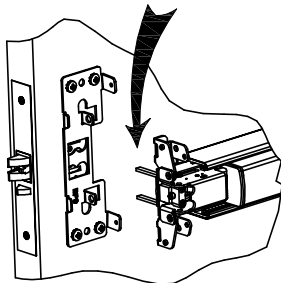

IMPORTANT!

Fasten device to backplate with (2) "B" screws.
If screws are not installed, warranty is void.

1/4" Lockwasher

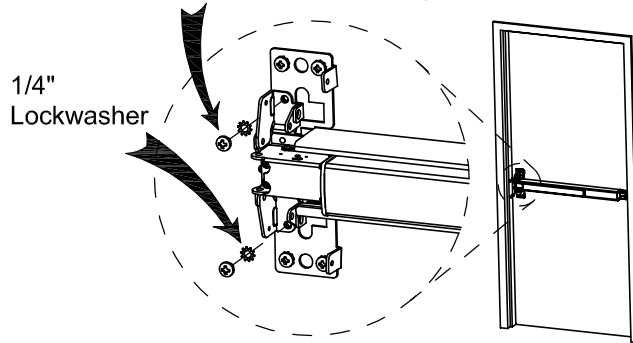

CHECKING FOR DEVICE CLEARANCE (Cut-Off procedure if required)

Slide endcap assembly onto extrusion

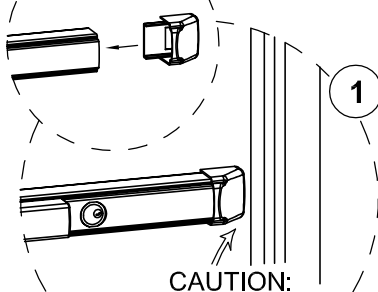

CAUTION:

Check for device and door frame clearance.
If no cut-off needed, proceed to the next page.

Minimum Fillerplate Length	
Type	Length (L)
LD	2-1/2"
HD/CD	3"

2

Cut fillerplate and extrusion STRAIGHT & SQUARE to desired length and deburr

Secure with tape before cutting

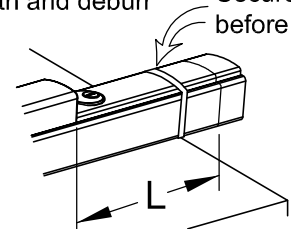

For aluminum Advantex finish cutdown applications: After cutting, the baseplate extrusion can be reversed to place the cut end inside the head cover. To do so, loosen the setscrew inside the aluminum baseplate extrusion and slide extrusion out, reverse, & slide back in. Tighten setscrew.

6 Level device and install endcap bracket

Drill for "A" or "F" screws, 2 places
OR use #14 self-drilling "K" screws

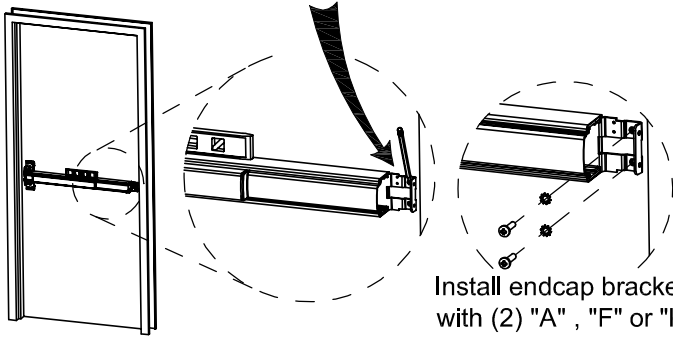

Install endcap bracket
with (2) "A", "F" or "K" screws
AND (2) lockwashers

7 Install endcap and cover

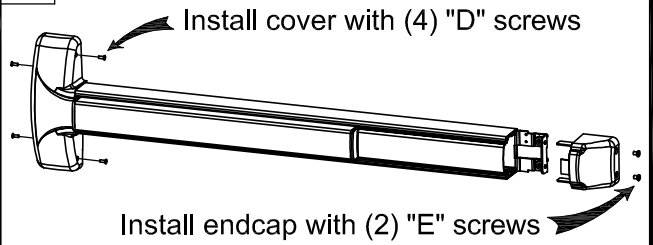

Install cover with (4) "D" screws
Install endcap with (2) "E" screws

INSTALLING OKC (03) FUNCTION

(if required, to be done between steps 2 & 3 on sheet 2)

Use plastic template to mark and drill hole (Trim side only)

CAUTION!

Mortise lock NOT installed for this step

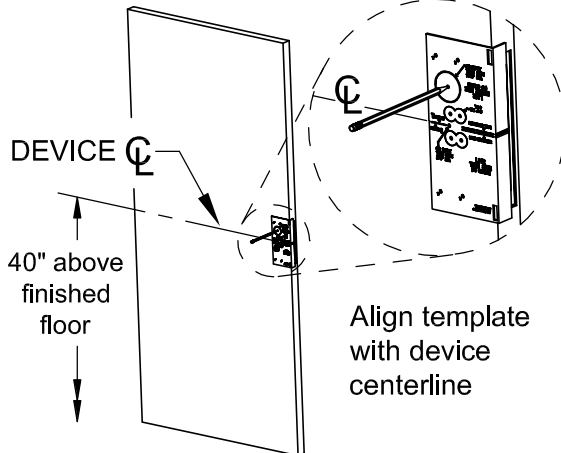

Drill 1-1/4" dia, one side

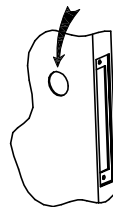

Install lock with (2) "I"
screws or (2) "J" screws
for wood doors. Fasten
screws loosely.

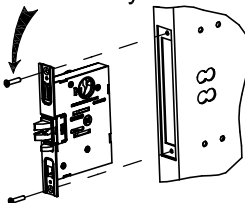

Install cylinder AFTER lock is installed

Turn cylinder CW

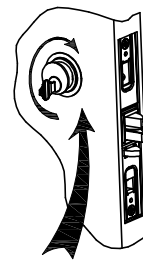

Cylinder and collar
NOT supplied, but
can be ordered
separately.

Cylinder P/N: 102281-X
Collar P/N: 103303

Tighten screws

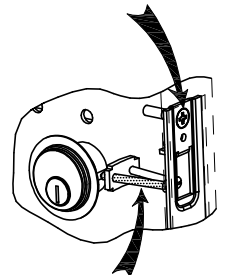

Tighten screw
nearest cylinder
side of door only

**Continue with Step 2
on page 2**

TROUBLESHOOTING

Adjust centercase fingers, if latchbolt will not retract fully

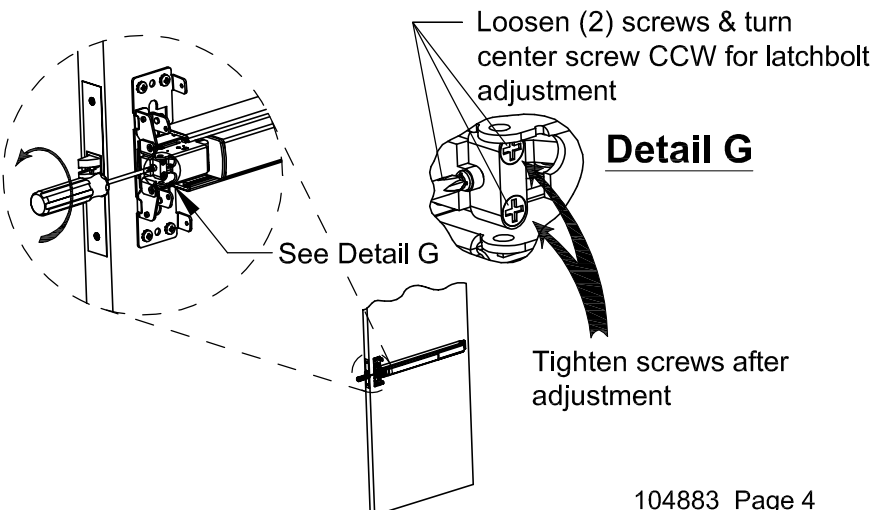

Loosen (2) screws & turn
center screw CCW for latchbolt
adjustment

Detail G

See Detail G

Tighten screws after
adjustment

Optional Accessories

Glass Bead Kit

Part No: 103319



#1/4-20 X 1-1/2" Screw
(4) Included

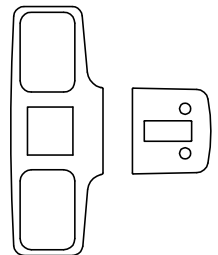

Sex Nut

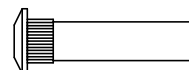

The #1/4-20 kit is available in (4) finishes:

Part No: 101616-2 Brushed Brass BHMA 606 Finish
Part No: 101616-5 Oil Rubbed Bronze BHMA 613 Finish
Part No: 101616-7 Brushed Chrome BHMA 626 Finish
Part No: 101616-9 Stainless Steel BHMA 630 Finish