

Detex Corporation, 302 Detex Drive, New Braunfels, Texas 78130-3045
(830)629-2900 / 1-800-729-3839 / Fax (830)620-6711
E-MAIL: detex@detex.com INTERNET: www.detex.com

INSTALLATION INSTRUCTIONS FOR ADVANTEx® CONCEALED VERTICAL ROD

ADVANTEx®

Concealed Vertical Rod Exit Device

60 / F60 / 61 / F61 Series

Drawing no. 105260

for Narrow to Wide Stile
Aluminum or FRP
door applications

Fits 2" minimum stile width

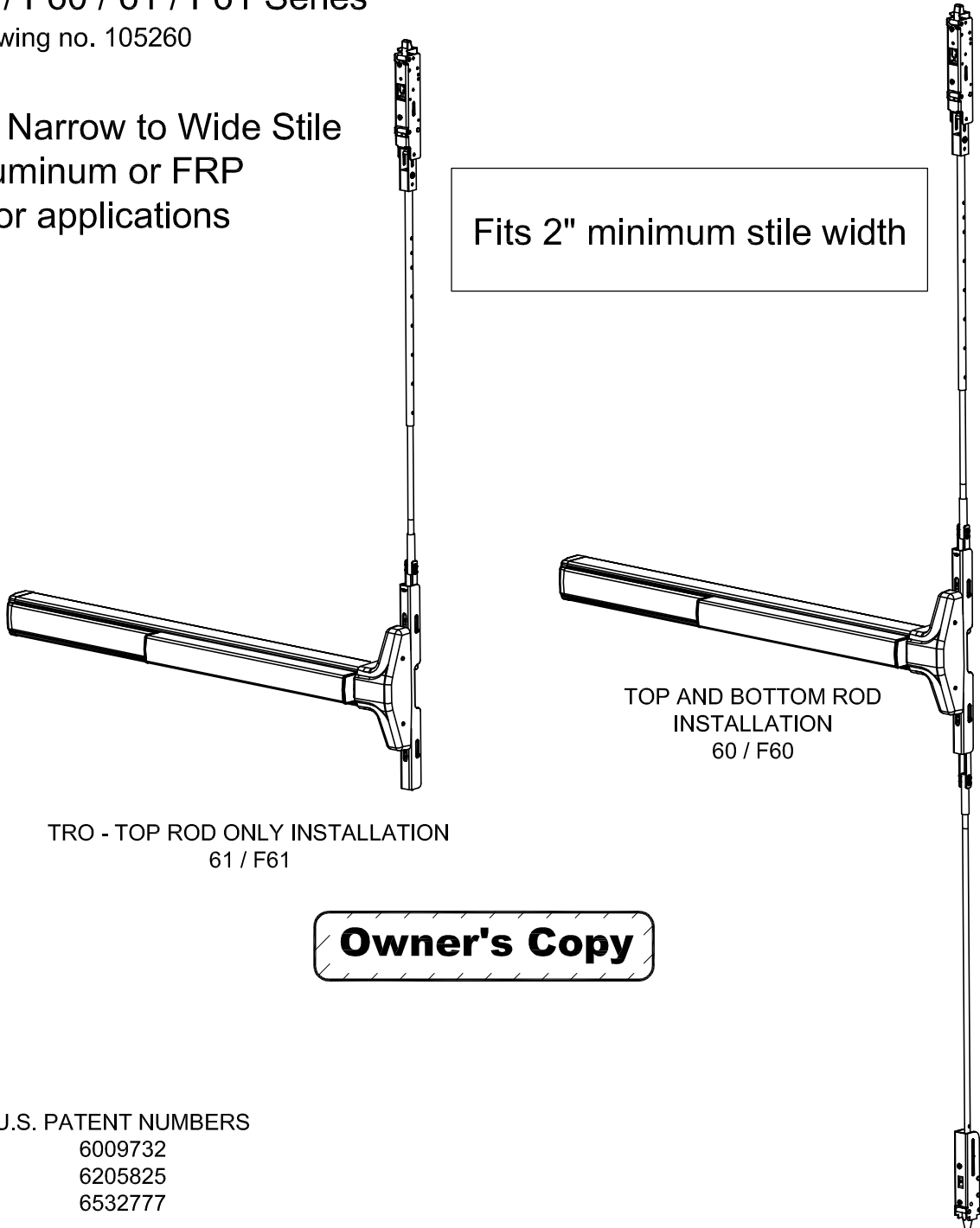

TRO - TOP ROD ONLY INSTALLATION
61 / F61

TOP AND BOTTOM ROD
INSTALLATION
60 / F60

Owner's Copy







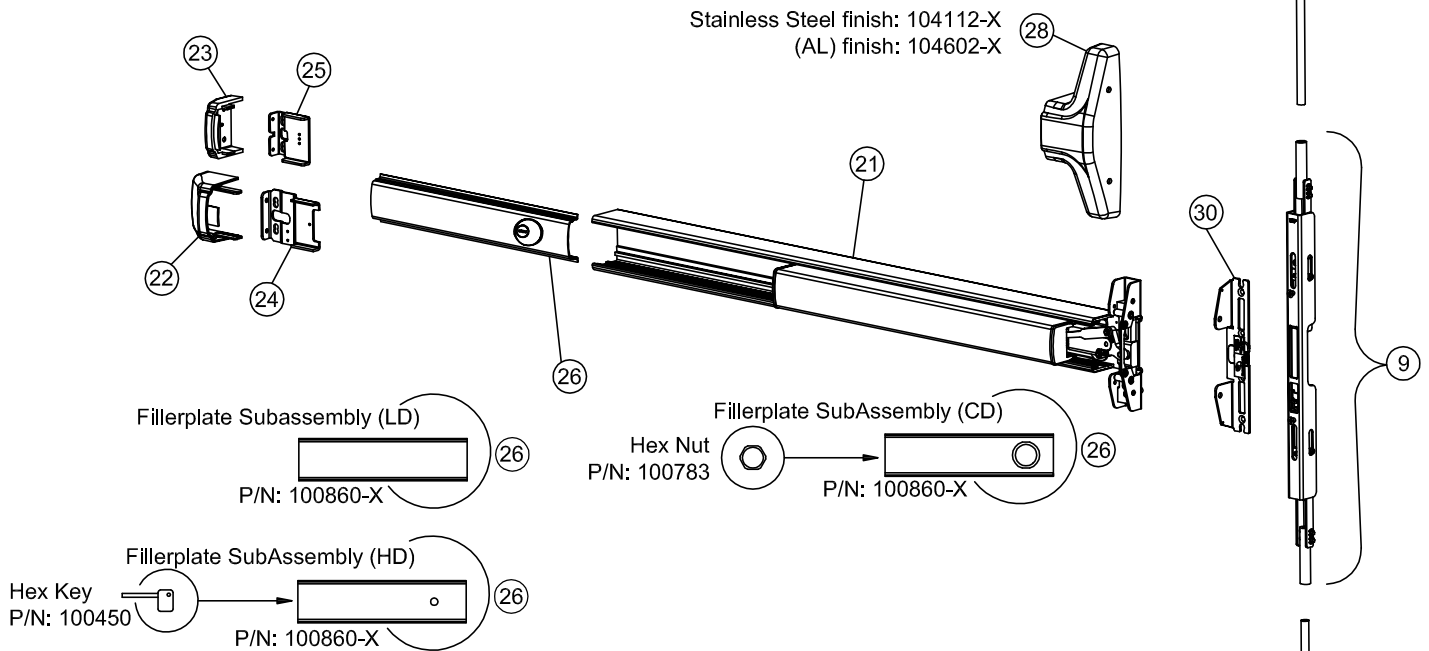



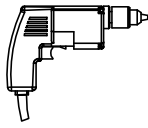

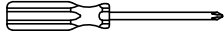

U.S. PATENT NUMBERS
6009732
6205825
6532777

ITEM#	DESCRIPTION	Fire	Panic Non-fire	PART NUMBER
		QTY	QTY	
1	Top strike kit	1	1	105257-2
2	CVR strike shim	1	1	105246
3	CVR top strike pocket	1	1	105235-1
4	CVR top strike insert	1	1	105236-1
6	Top latch (Panic)		1	104121-1
	Top latch (Fire)	1		104121-2
7	Outer top rod, 7' thru 8'	1	1	104187
	Outer top rod, 8'-1" thru 10'			105097
8	Inner top rod, 7' thru 8'	1	1	104172-1
	Inner top rod, 8'-1" thru 10'			104172-2
9	Center lift mechanism assembly	1	1	104175-X
10	CVR bottom rod	1	1	105098
11	Bottom latch, Aluminum application	1	1	104190-1
12	Bottom strike kit	1	1	105257-3
13	Spring pin 3/16 x 13/16	1	1	105296
14	Spring pin 3/16 x 1/2	1	1	103423

* Note: Parts listed will vary according to product configuration.
Mortise cylinder available as an option. Standard Yale type cam required.
See Mortise cylinder installation page.

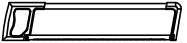







ITEM#	DESCRIPTION	QTY	PART NUMBER
21	S&R CVR Centercase/Pushpad Assy	1	105500-X
22	Endcap (EC1) (SS)	1	101642-X
23	Flush endcap (EC2) (AL)	1	104612-X
	Flush endcap (EC2) (SS)		104304-X
24	Endcap mounting bracket (EC1)	1	100147
25	Flush endcap mounting bracket (EC2)		104303
26	S & R Fillerplate subassembly	1	see above
27			
28	Narrow centercase cover	1	see above
29			
30	Narrow back plate (BP10 OR BP12)	1	104148-X

Tools Required				
Power Drill 	Safety Glasses 	Tape Measure 	Pencil 	Center Punch 
Hammer 	Screw Drivers - Phillips, Small Flat 	Tap Wrench 	Pliers 	Level 
Hack Saw (chopsaw preferred) 	Hex Wrench - 5/64 	Masonry Blits - 1", 5/16", 3/16" 	Drill bit set 	

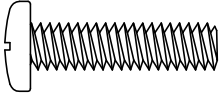
Fastener Table

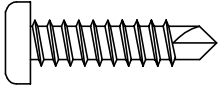
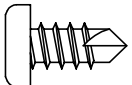
(Look for letter designation throughout instruction when screws are called for)

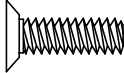
Device Mounting Hardware p/n: 105258-X

	screw style & size	description	used on
A	  lockwasher used with screws A	1/4-20 x 1" PPHMS	Hollow metal / aluminum doors: backplate & endcap bracket to door
B		#14 x 1" PPH self-drilling	Hollow metal / aluminum doors: backplate & endcap bracket to door (alternate)
C		#14 x 1/2" PPH self cutting	Wood doors: backplate to door & endcap bracket
D		10-24 x 1/4" PPHMS	Device centercase to backplate
E		10-24 x 5/8" PFHUMS	Centerlift mechansim to backplate
F	 (multiple finishes included)	10-32 x 5/16" PFHUMS	Endcap to endcap bracket
G	 (multiple finishes included)	6-32 x 3/8" PFHUMS	Centercase cover to backplate

Strike Mounting Hardware p/n: 105257-X

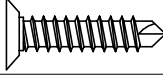
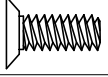
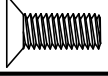
H	 (used with anchors, two styles of anchors included)	#10 x 1" self-cutting PFHU	Bottom strike to floor
I		10-24 x 1/2" PFHUMS	Bottom strike to floor (alternate)
J		10-32 x 1/2" PFHMS	Top strike pocket to header, insert to pocket

Latch Mounting Hardware p/n: 105261-X

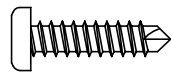
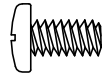
K		10-24 x 5/16" PFHUMS	Aluminum doors: Latch to door Hollow Metal / Wood: top latch bracket to housing
L		#10 x 3/4" PPH self-cutting	Wood doors: Top & bottom latch mounting brackets to door
M		10-24 x 3/8" PPHMS	Hollow Metal / Wood doors: bottom bracket to latch Hollow Metal doors: Top & bottom latch brackets to door

!!!CHECK BEFORE STARTING!!!

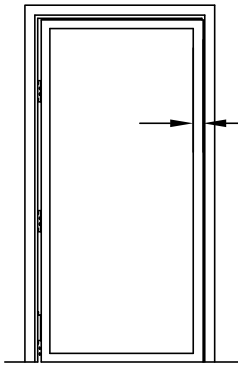

Stile width
Verify that minimum stile width requirement is met (see chart on front page).

Doors and frames with walls having a structural thickness (metal skin plus reinforcement) to engage less than (3) full screw threads, are considered unreinforced for hardware.

Unreinforced Doors: Use Sex Nuts and Bolts
Unreinforced Frames: Use Blind Rivet Nuts (see sketch).
Fasteners for unreinforced openings are not supplied by Detex.

Reinforced door or frame engages at least (3) screw threads.

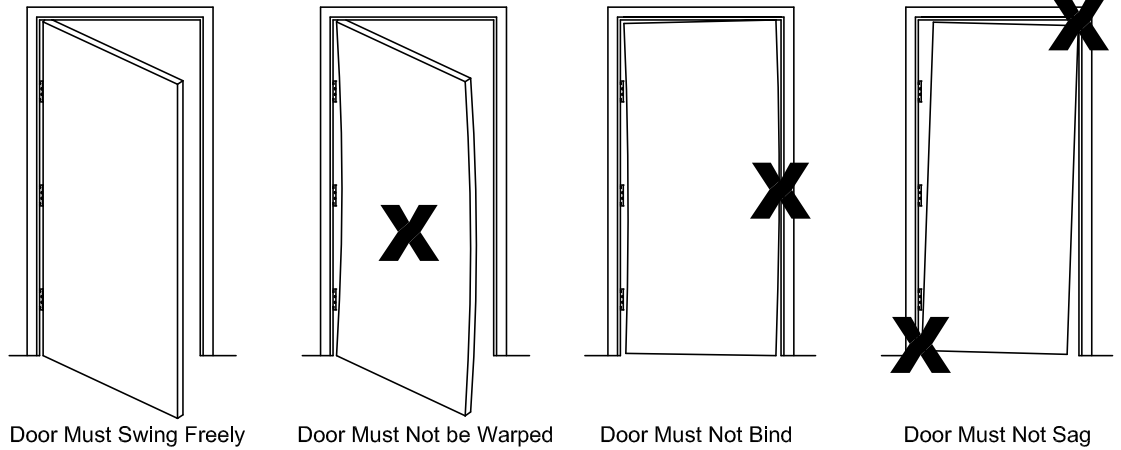
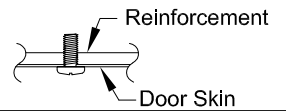

NOTE: LOCAL CODES MAY REQUIRE THROUGH BOLTING. SEX NUTS ARE **NOT** INCLUDED WITH THIS DEVICE. SEX NUTS CAN BE PURCHASED SEPARATELY.

STEP 1: DOOR / OPENING MEASUREMENTS

Measure per figure below:

*These dimensions will be needed during rod length adjustment. Measure door before removing.

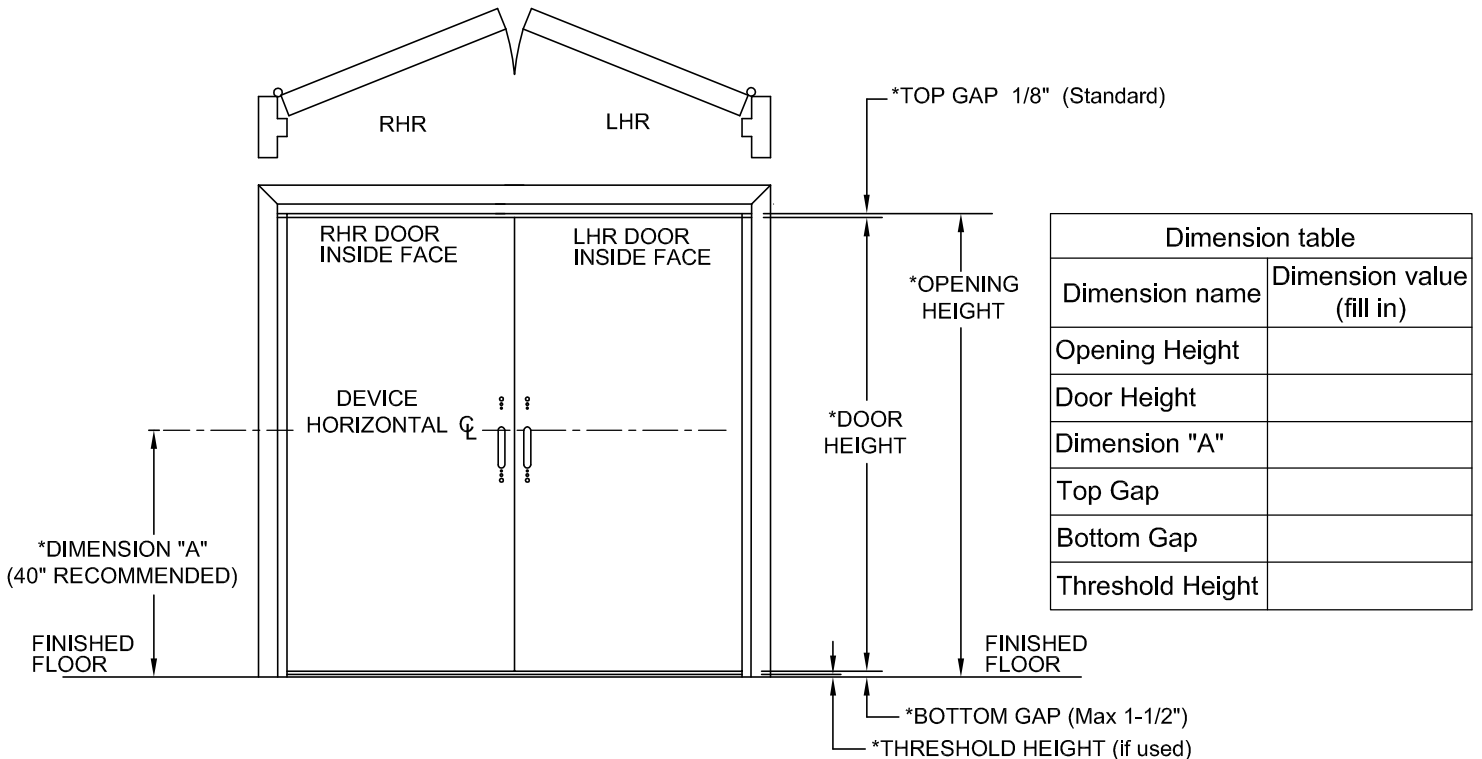

STEP 2: DOOR PREP - ALUMINUM & FRP DOOR

INSTALLATION SHOWN IN THIS INSTRUCTION IS FOR
 RIGHT HAND REVERSE (RHR)
 LEFT HAND REVERSE (LHR) WILL BE OPPOSITE

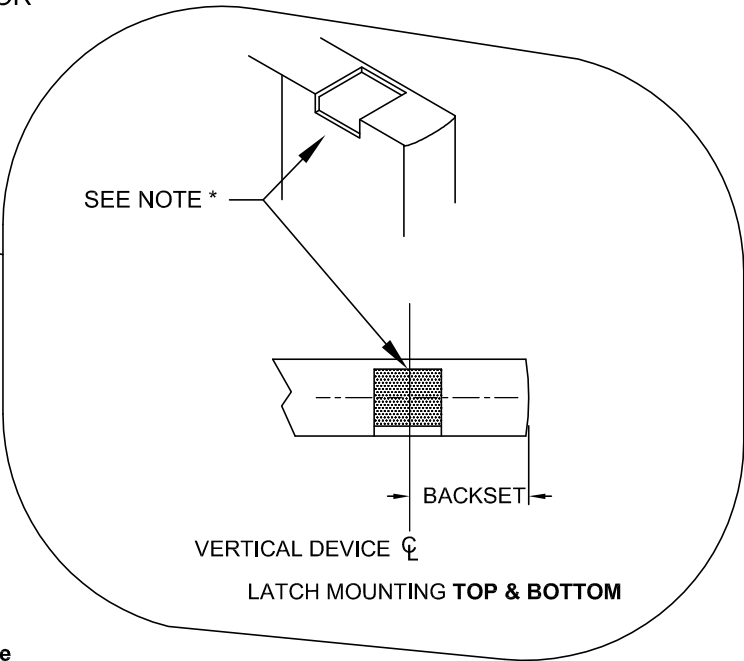
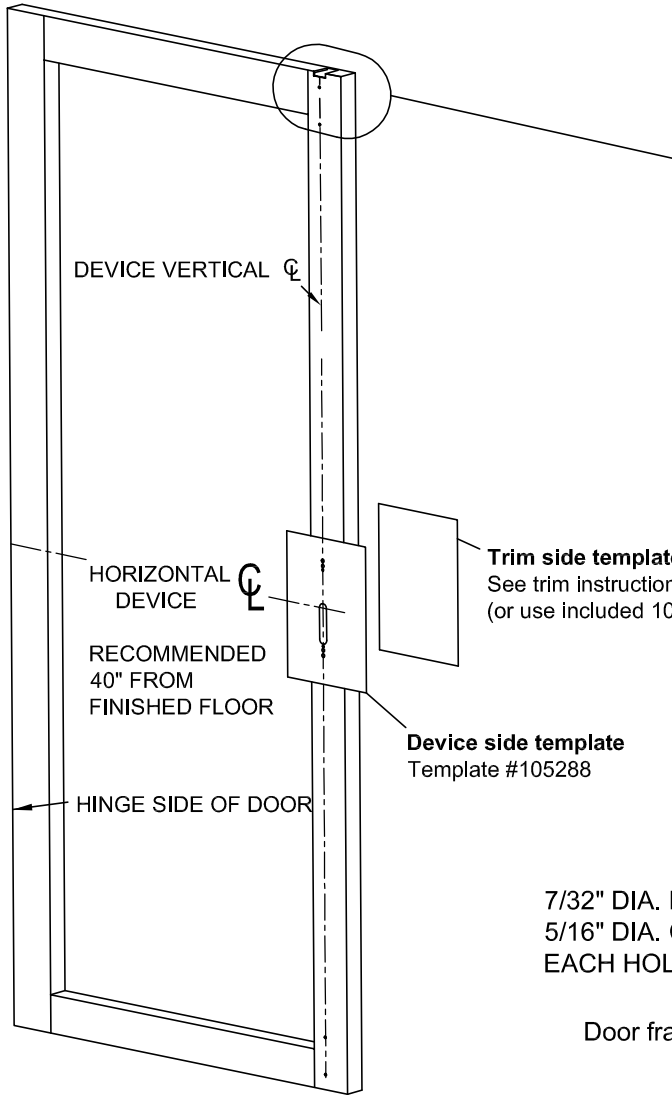

Trim side template
 See trim instructions if required
 (or use included 105289 for 03CAK function or sexnut installation)

Device side template
 Template #105288

TOP STRIKE FRAME PREP (if not already prepped)

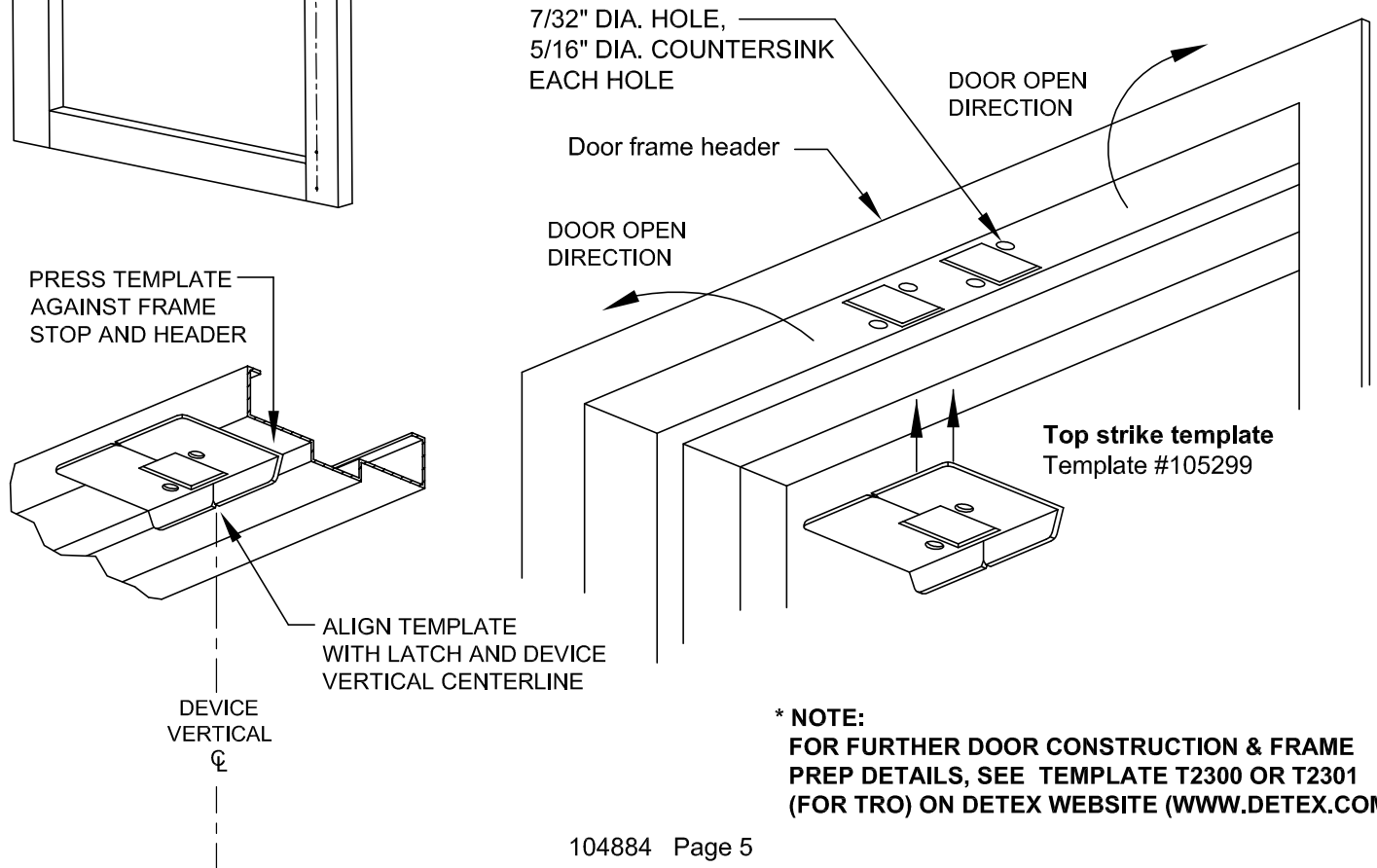

*** NOTE:**
 FOR FURTHER DOOR CONSTRUCTION & FRAME
 PREP DETAILS, SEE TEMPLATE T2300 OR T2301
 (FOR TRO) ON DETEX WEBSITE (WWW.DETEX.COM)

For 6'-8" (80") to 8'-0" (96") Door

STEP 3: TOP ROD ASSEMBLY & INITIAL ADJUSTMENT

3a. Align hole A in rod 104187 with hole in top latch as shown at right & tap the 13/16" long pin into latch hole.

3b. Measure **DIM B** as shown below.

3c. Use chart to determine pinning location of rods 104187 & 104172-1.

Round **DIM B** to nearest value in chart.

If more than 3/4" different from one of these chart values, drill a .189 (#12 drill bit) diameter hole halfway between the 2 holes nearest to the measured **DIM B** and use this hole as pinning hole in next step.

3d. Insert 104172-1 rod into 104187 rod & line up appropriate pinning holes (from chart) on both rods and tap in the 1/2" long pin to secure.

3e. Calculate **DIM D**:

(**DIM D** = measured **DIM B** minus 15 7/8")

Thread the assembled rods/latch into the centerlift mechanism assembly as shown at right until **DIM D** is achieved (within 1/16").

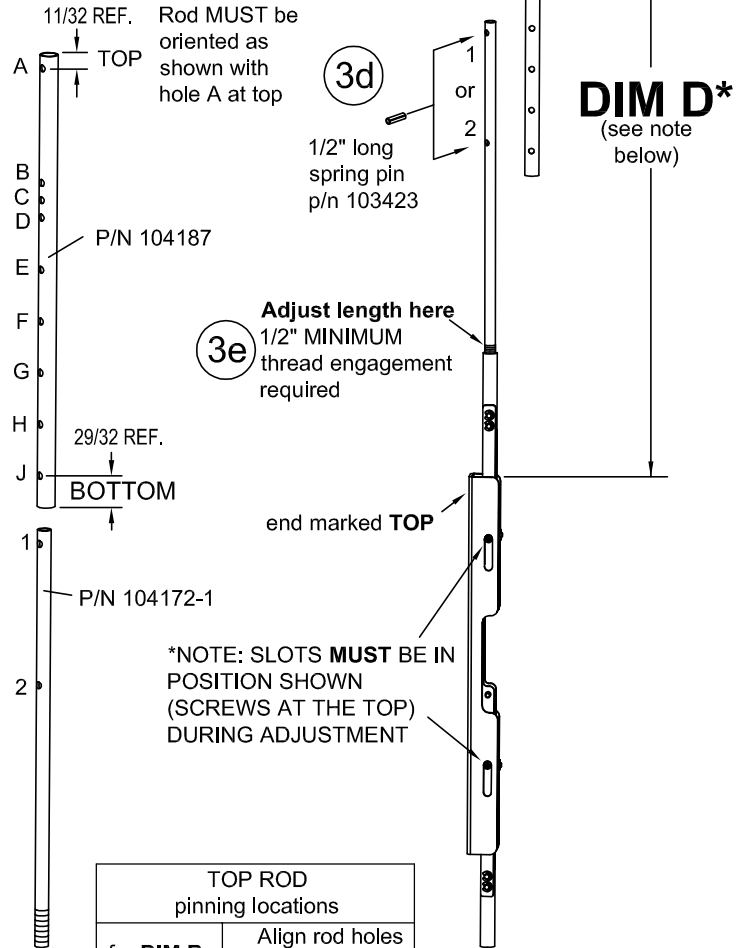
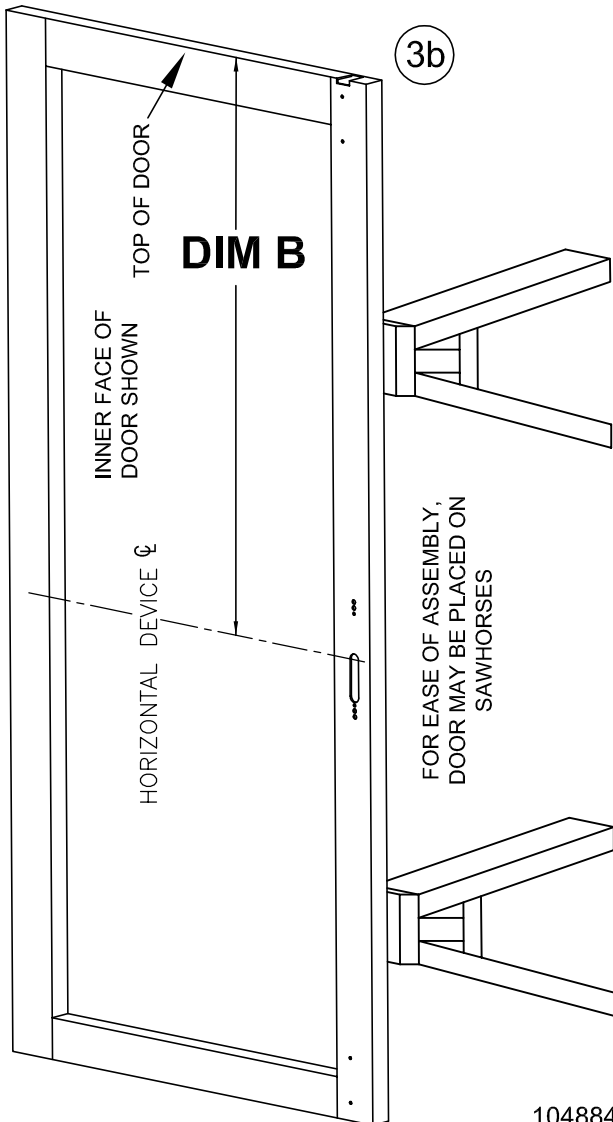

TOP ROD pinning locations		
for DIM B dimension of:	Align rod holes	
	Rod p/n 104172-1	Rod p/n 104187
	HOLE	HOLE
39-7/8"	2	B
40-7/8"	2	C
41-7/8"	2	D
43-7/8"	1	B
44-7/8"	1	C
45-7/8"	1	D
47-7/8"	1	E
49-7/8"	1	F
51-7/8"	1	G
53-7/8"	1	H
55-7/8"	1	J

Note: If the combination of holes used is 2B or 2C, cut off approximately 2" from the UNTHREADED end of rod 104172-1

For 8'-1" (97") to 10' (120") Door

STEP 3: TOP ROD ASSEMBLY & INITIAL ADJUSTMENT

3a. Align hole A in rod 105097 with hole in top latch as shown at right & tap the 13/16" long pin into latch hole.

3b. Measure **DIM B** as shown below.

3c. Use chart to determine pinning location of rods 105097 & 104172-2.

Round **DIM B** to nearest value in chart.

If more than 3/4" different from one of these chart values, drill a .189 (#12 drill bit) diameter hole halfway between the 2 holes nearest to the measured **DIM B** and use this hole as pinning hole in next step.

3d. Insert 104172-2 rod into 105097 rod & line up appropriate pinning holes (from chart) on both rods and tap in the 1/2" long pin to secure.

3e. Calculate **DIM D**:

(**DIM D** = measured **DIM B** minus 15 7/8")

Thread the assembled rods/latch into the centerlift mechanism assembly as shown at right until **DIM D** is achieved (within 1/16").

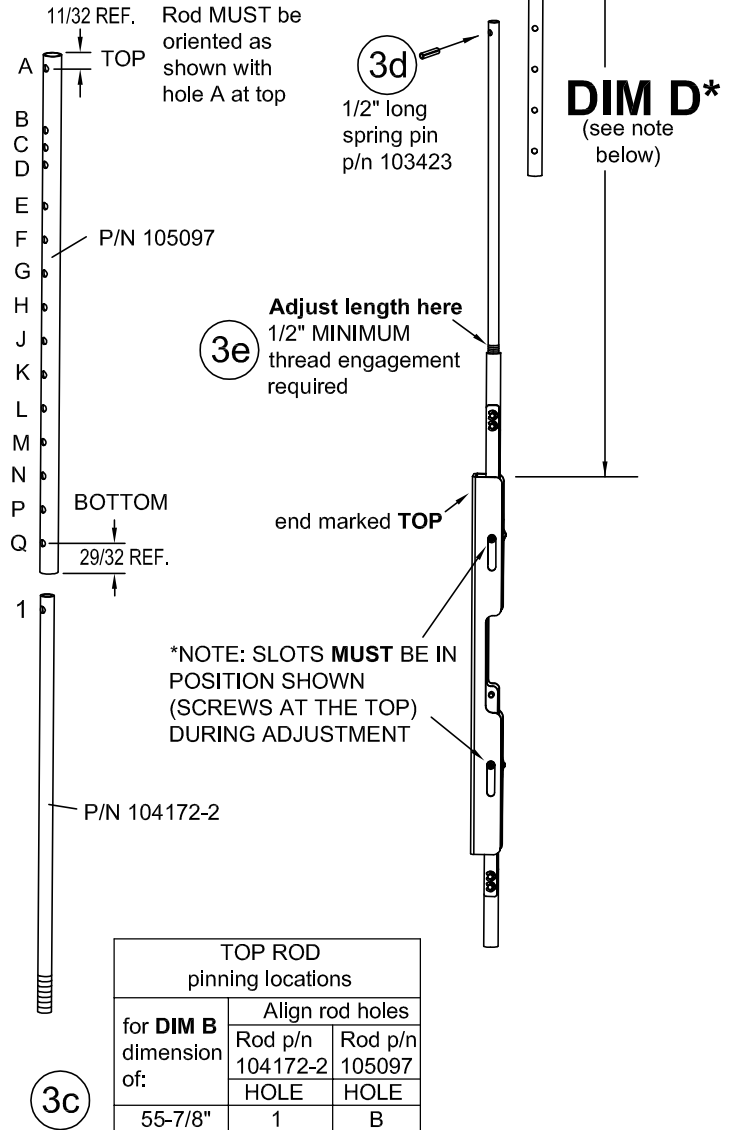
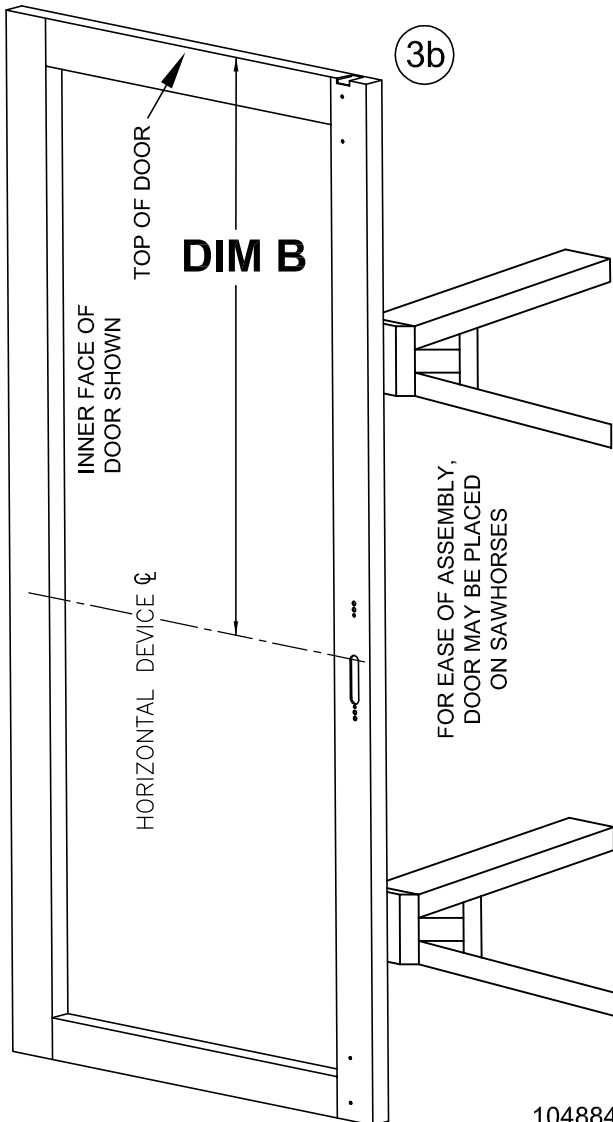

TOP ROD pinning locations		
for DIM B dimension of:	Align rod holes	
	Rod p/n 104172-2 HOLE	Rod p/n 105097 HOLE
55-7/8"	1	B
56-7/8"	1	C
57-7/8"	1	D
59-7/8"	1	E
61-7/8"	1	F
63-7/8"	1	G
65-7/8"	1	H
67-7/8"	1	J
69-7/8"	1	K
71-7/8"	1	L
73-7/8"	1	M
75-7/8"	1	N
77-7/8"	1	P
79-7/8"	1	Q

STEP 4: BOTTOM ROD / LATCH ASSEMBLY & ADJUSTMENT (Disregard if TRO device is being installed)

4a. Using **DIM A** as measured in step 1, use chart to determine pinning location.

4a

Align rod holes with bottom latch (round **DIM A** to nearest value shown)

DIM A (device \varnothing at distance from floor)	Bottom Rod p/n: 105098 use HOLE
38"	V
39"	W
40"	X
40-3/8"	Y
40-3/4"	Z

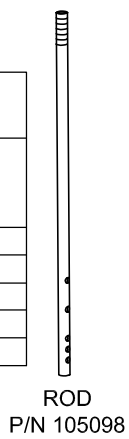

If **DIM A** is less than 37-1/4" from finished floor, a new pin hole must be drilled through 105098 rod. Subtract the centerline dimension from 38" and measure up this distance from hole V. Mark and drill .189 diameter hole (#12 drill).

If **DIM A** is more than 41-1/2", from floor, call customer service at 1-800-729-3839 for assistance.

Note: If hole V or W is used (or if new hole is drilled closer to threaded end), trim off UNTHREADED end of rod as needed to allow rod to slide into bottom bolt far enough to pin.

4b. Remove clip 103551 and slide pin out. Place bottom rod 105098 into bolt, line up holes and replace pin and place clips into pin grooves.

4c. **DIM C** is the target length.

For no threshold or threshold 1/2" or less:

DIM C = measured **DIM A** minus 8".

For threshold greater than 1/2":

DIM C = measured **DIM A** minus 8" minus threshold height

NOTE: SLOTS MUST BE IN POSITION SHOWN (SCREWS AT THE TOP) DURING ADJUSTMENT

4d. Thread bottom rod into centerlift mechanism to achieve **DIM C** (within 1/16").

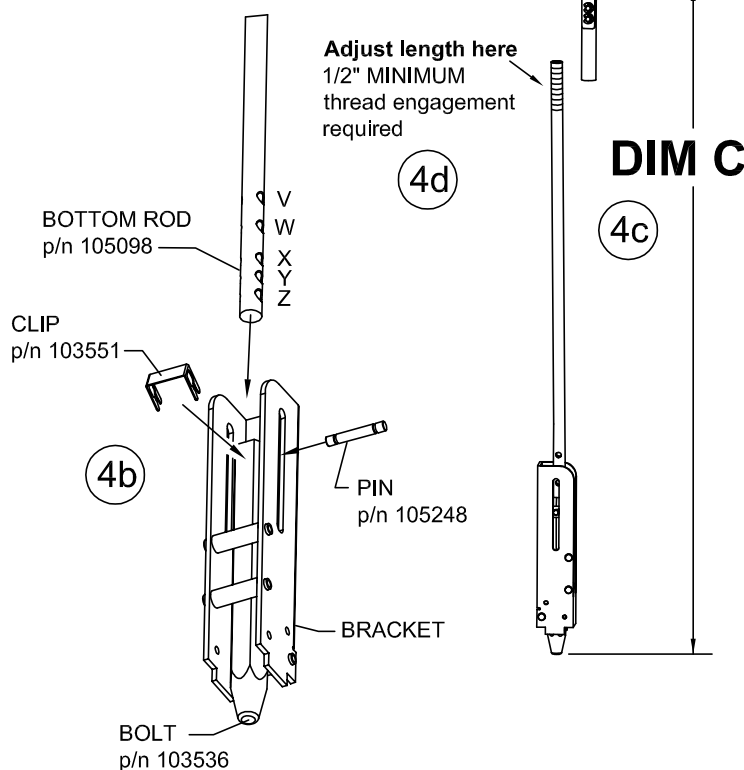
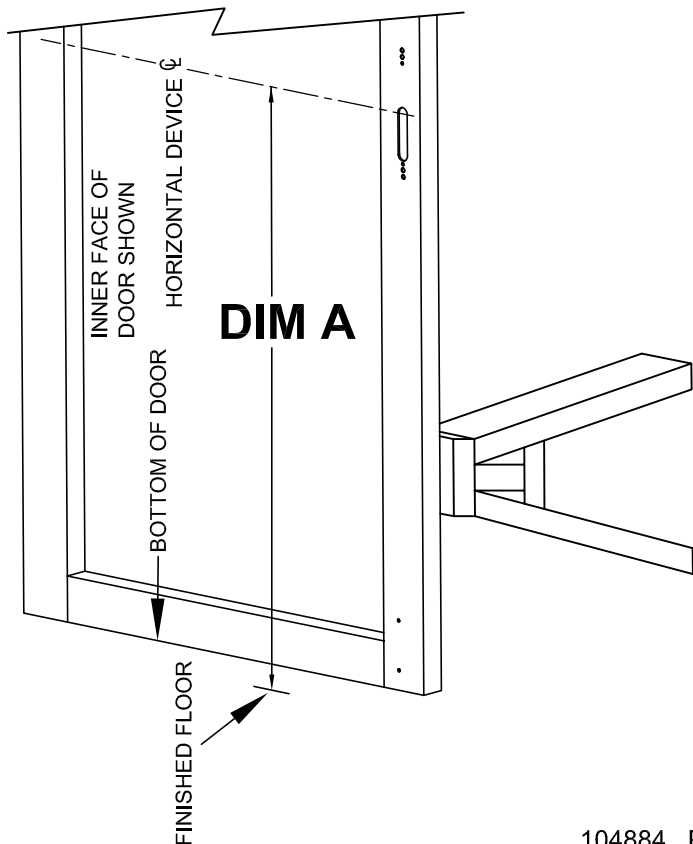

STEP 5: VISUAL ALIGNMENT CHECK:

5a. Lay internal latch components onto door for trial fit. Take care to protect door finish.

5b. Ensure top latch is in retracted position. Hold top rod in place and push top latch case towards device  until latchbolt is fully retracted.

5c. Mounting holes for top latch, centerlift and bottom latch should line up with mounting holes in door. If not, go back to steps 3 & 4 and verify rod length dimensions.

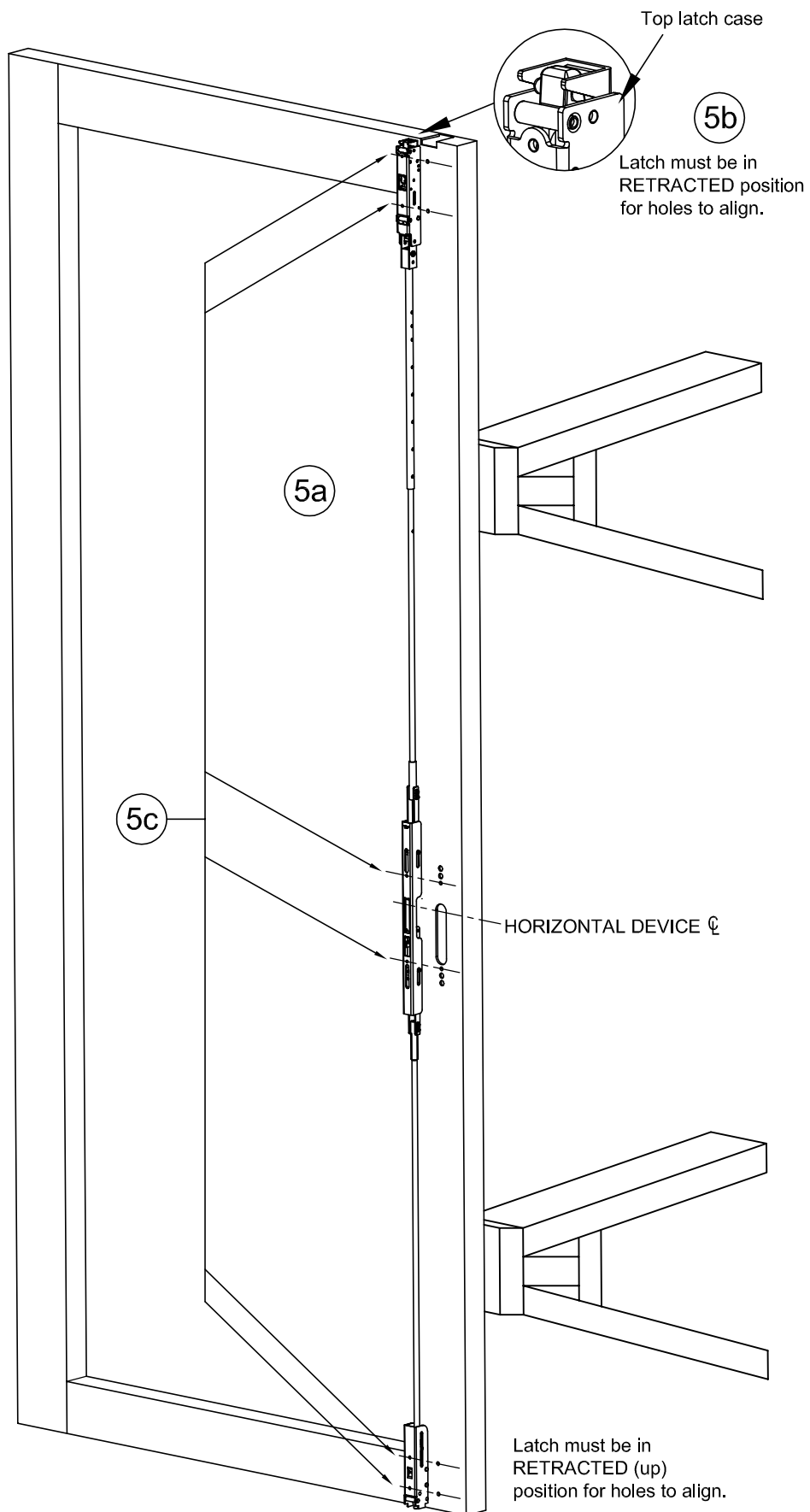

STEP 6: ATTACH TOP LATCH MOUNTING BRACKETS

No brackets necessary for aluminum door applications - continue to step 7

STEP 7: INSERT ROD / LATCH / CENTERLIFT ASSEMBLY INTO DOOR

7a. Align surfaces as shown below.

7b. Gently insert assembly through door top, taking care to maintain assembly orientation.

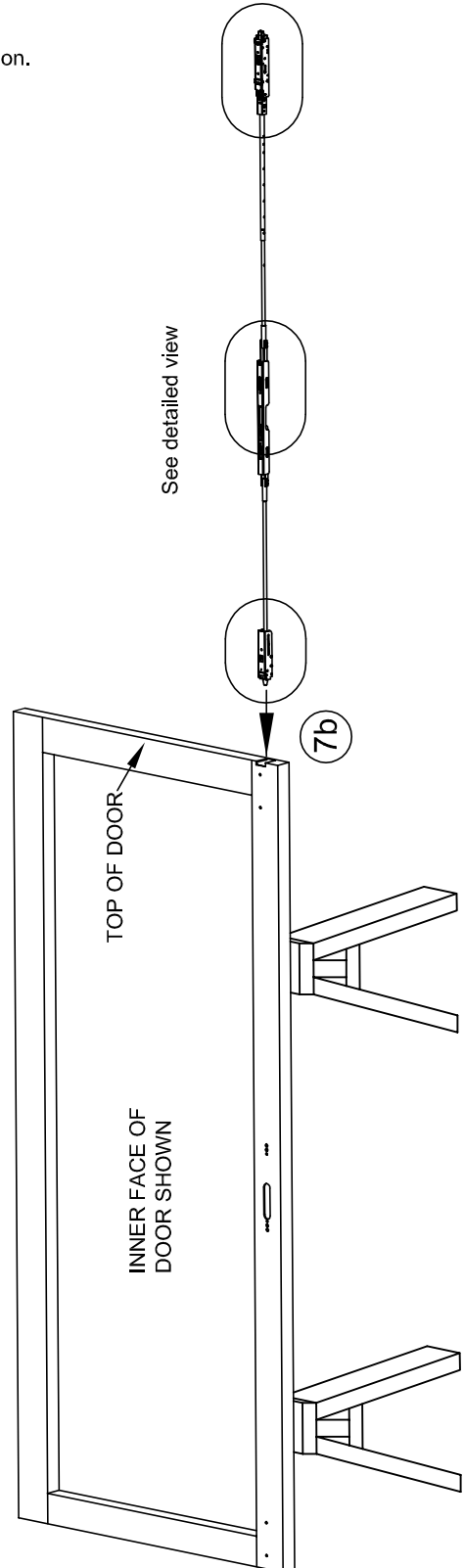
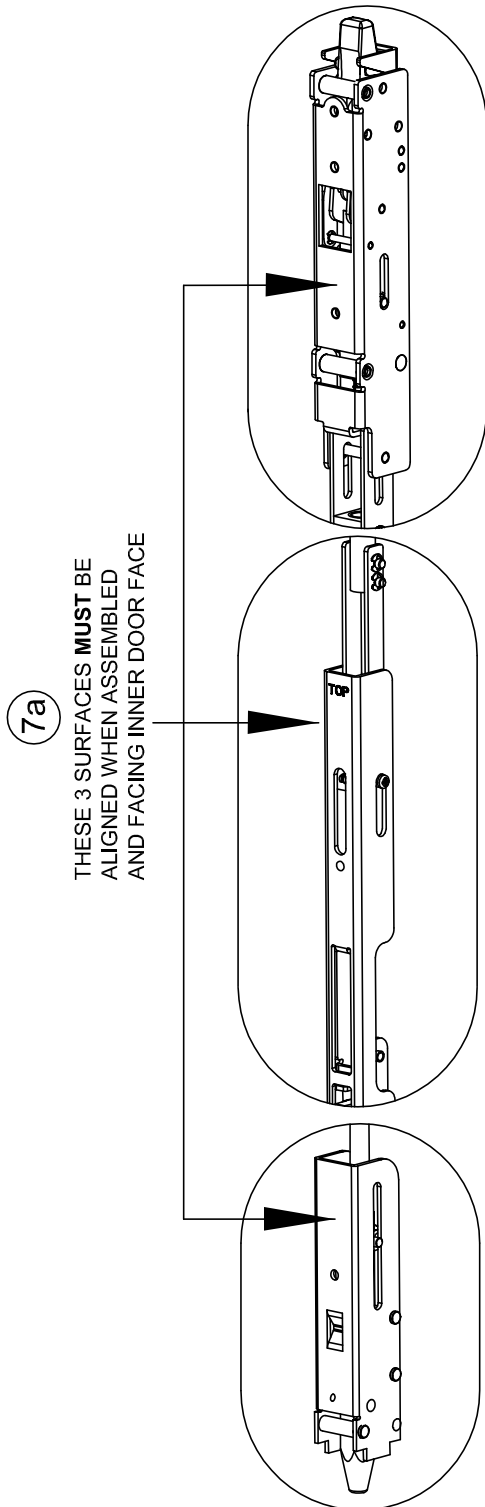

STEP 8: SECURE ROD / LATCH / CENTERLIFT ASSEMBLY TO DOOR

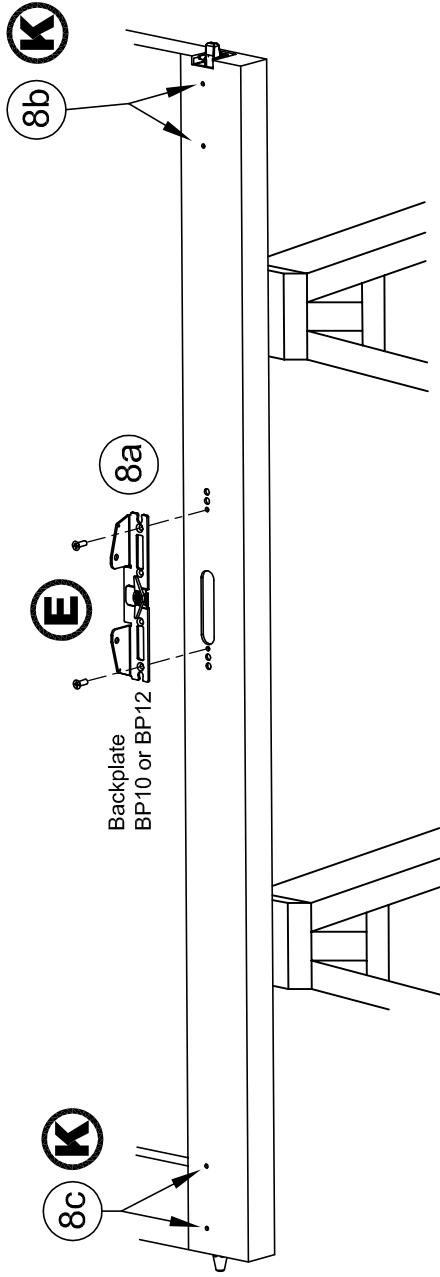

8a. Attach back plate with two screws - DO NOT OVERTIGHTEN.

Assembly hint: Assemble one screw loosely without backplate, then add second screw through backplate. Remove first screw, align backplate and then re-install first screw.

8b. Attach top latch with two screws.
8c. Attach bottom latch with two screws.

STEP 9: VERIFY CENTERLIFT MECHANISM OPERATION

9a. Check current centerlift position using views shown.

9b. To extend latches, push and hold down on the holdback bracket to disengage the retraction feature, then use a screwdriver inserted into the activation slot to gently lower the slot to the extended position as shown.

9c. To retract latches, gently insert a screwdriver into the activation slot and raise the slot to the retracted position as shown.

TROUBLESHOOTING:

If latchbolt is fully extended while activation slot is not fully in the extended position, **then top rod is too short**. Go back to STEP 3 and correct.

If latchbolt is partially retracted while activation slot is fully in the extended position, **then top rod is too long**. In this case, latchbolt will be fully retracted before activation slot can travel fully to the retracted position. Go back to STEP 3 and correct.

9d. Bottom bolt drag check:

With top latch in retracted position, check to ensure that bottom bolt is not extending from bottom of door a distance greater than the bottom gap at finished floor (minus the threshold height if threshold is used). If it is, **then bottom rod is too long**. Go back to STEP 4 and correct.

9e. Upon completion, retract latches before proceeding to Step 10.

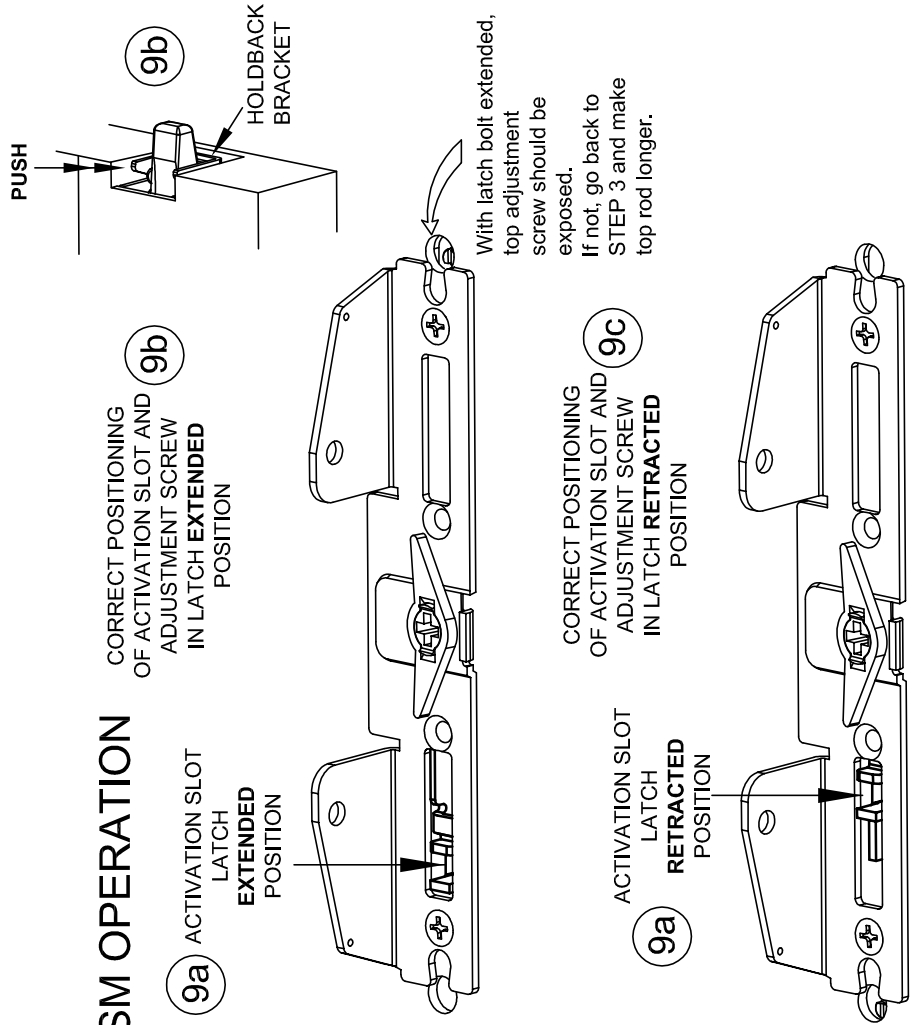

STEP 10: HANG DOOR / ASSEMBLE DEVICE TO DOOR

10a INSTALL DOOR ONTO FRAME PER MANUFACTURER'S SPECIFICATIONS

10b **NOTE: LINK SHOULD ALWAYS BE IN TOP POSITION**

Right Hand Reverse (RHR)

Left Hand Reverse (LHR)

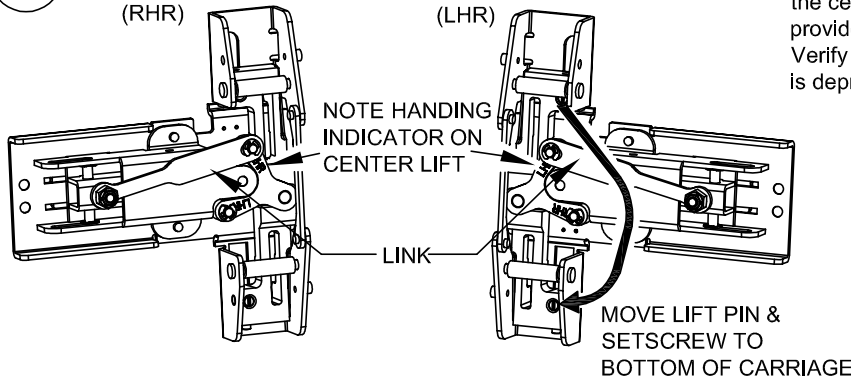

If link is not in uppermost position on the centerlift, carefully remove "E" clips and reposition link on top pin of the centerlift and replace "E" clips. (An additional "E" clip is provided on opposite link pin.)
Verify carriage moves up and down smoothly when pushpad is depressed and released.

10c REFER TO TRIM INSTRUCTIONS AT THIS TIME, IF APPLICABLE

10d COMPLETE BACKPLATE MOUNTING

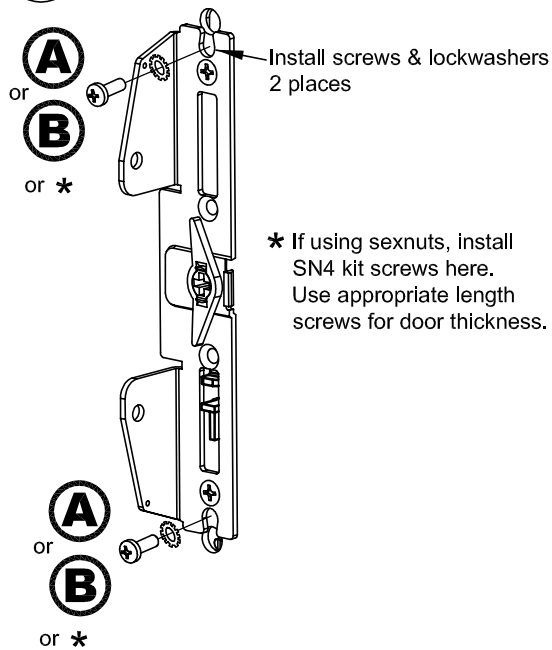

10e INSTALL DEVICE TO BACKPLATE

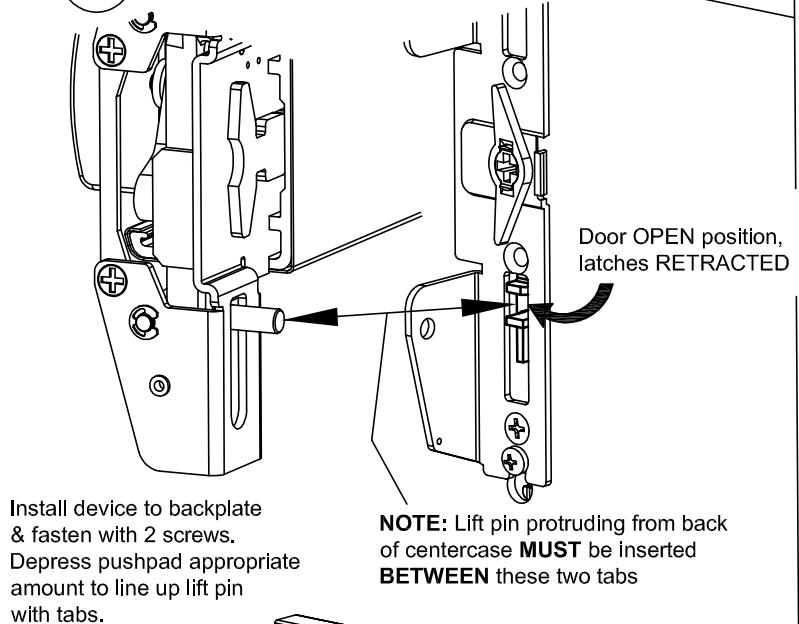

10f INSTALL ENDCAP BRACKET

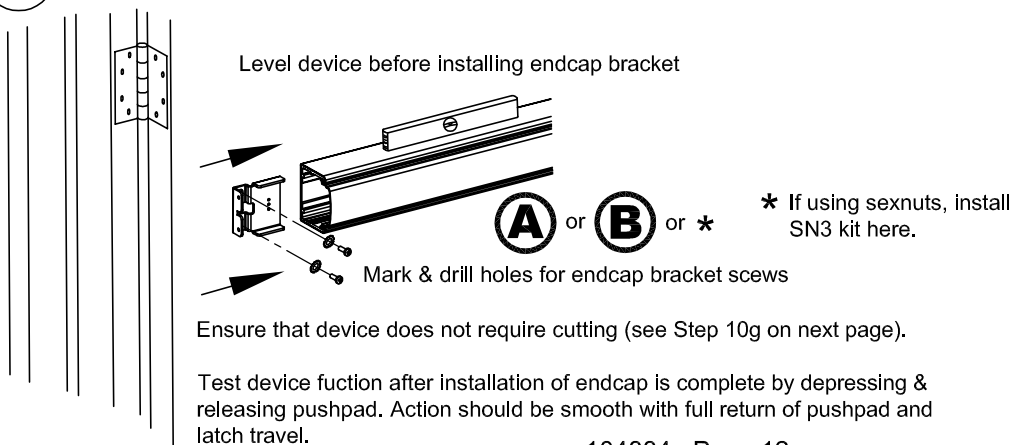

10g

CHECKING FOR DEVICE CLEARANCE (Cut-Off procedure if required)

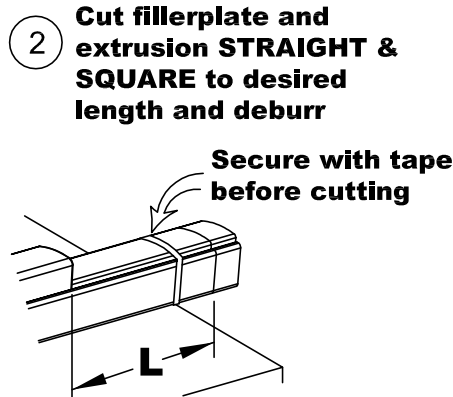
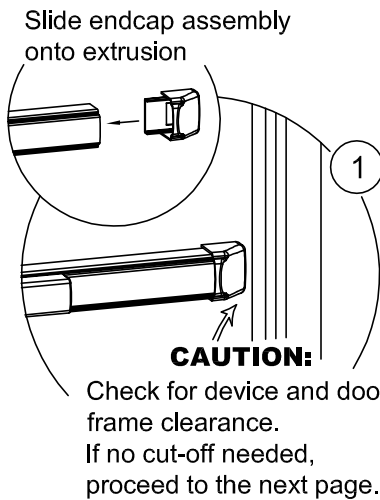

Minimum Fillerplate Length	
Type	Length (L)
LD	2-1/2"
HD/CD	3"

For aluminum Advantex finish cutdown applications:

After cutting, the baseplate extrusion can be reversed to place the cut end inside the head cover. To do so, loosen the setscrew inside the aluminum baseplate extrusion and slide extrusion out, reverse, & slide back in. Tighten setscrew.

10h

MORTISE CYLINDER INSTALLATION CD (Cylinder Dogging) Cylinder Installation

Cylinder nut socket
p/n 103779
(sold separately)

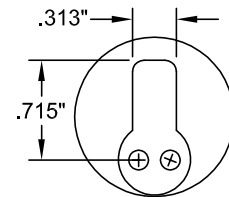
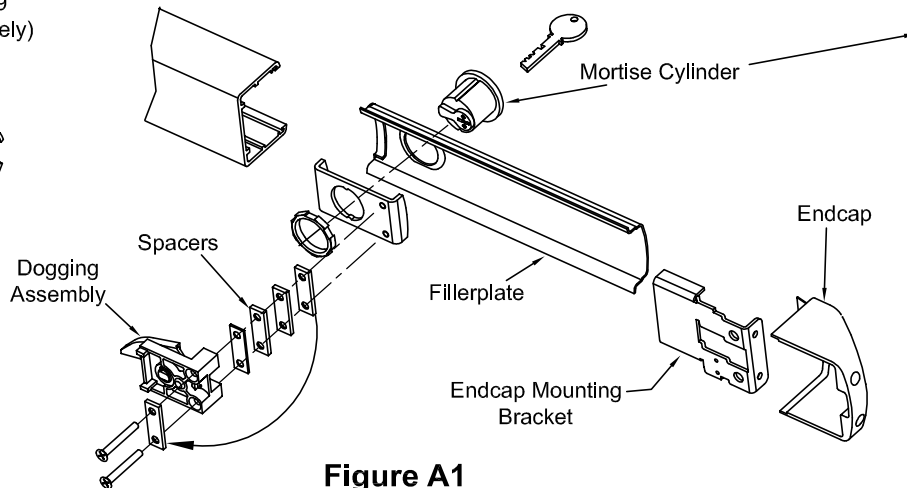

Mortise Cylinder with standard Yale cam required

Figure A1

Follow steps "a" through "g" for CD installations

- Remove endcap and endcap mounting bracket.
- Remove fillerplate.
- Remove and discard shipping insert and nut. Loosen (2) screws from dogging assembly.
- Install mortise cylinder (sold separately) with large hex nut provided.
- Trial fit dogging assembly. If cylinder is too short, remove spacers as necessary and reattach them under the (2) screw heads. Fasten the (2) screws to the rest of the assembly.

NOTE: The key should easily turn in both directions.

- Rotate key counterclockwise
- Assembly complete. Continue with Panic Hardware instruction.

STEP 11: TOP STRIKE INSTALLATION

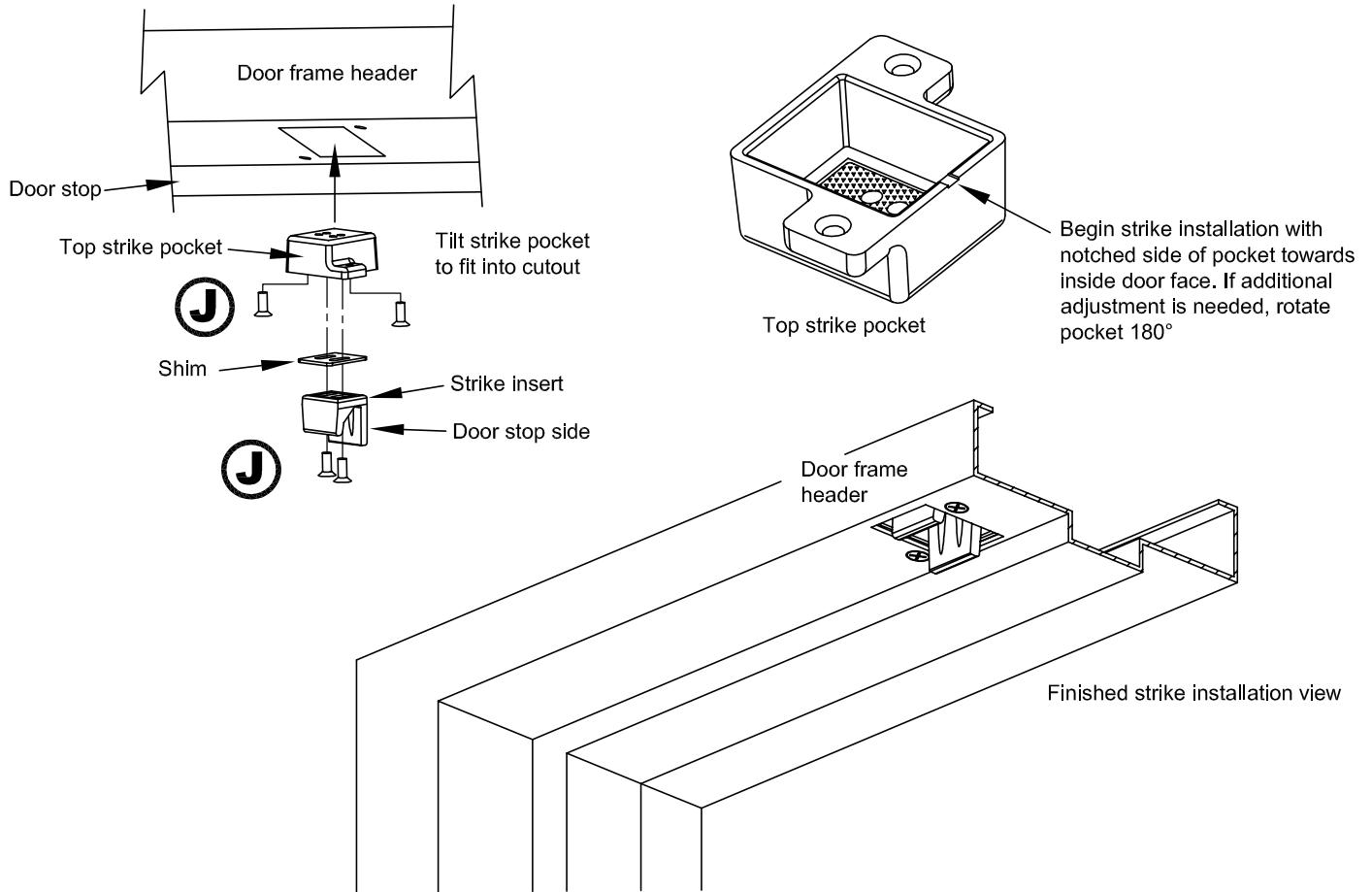

STEP 12: BOTTOM STRIKE INSTALLATION (Disregard if TRO device is being installed)

BOTTOM STRIKE HOLE LOCATION & DRILLING

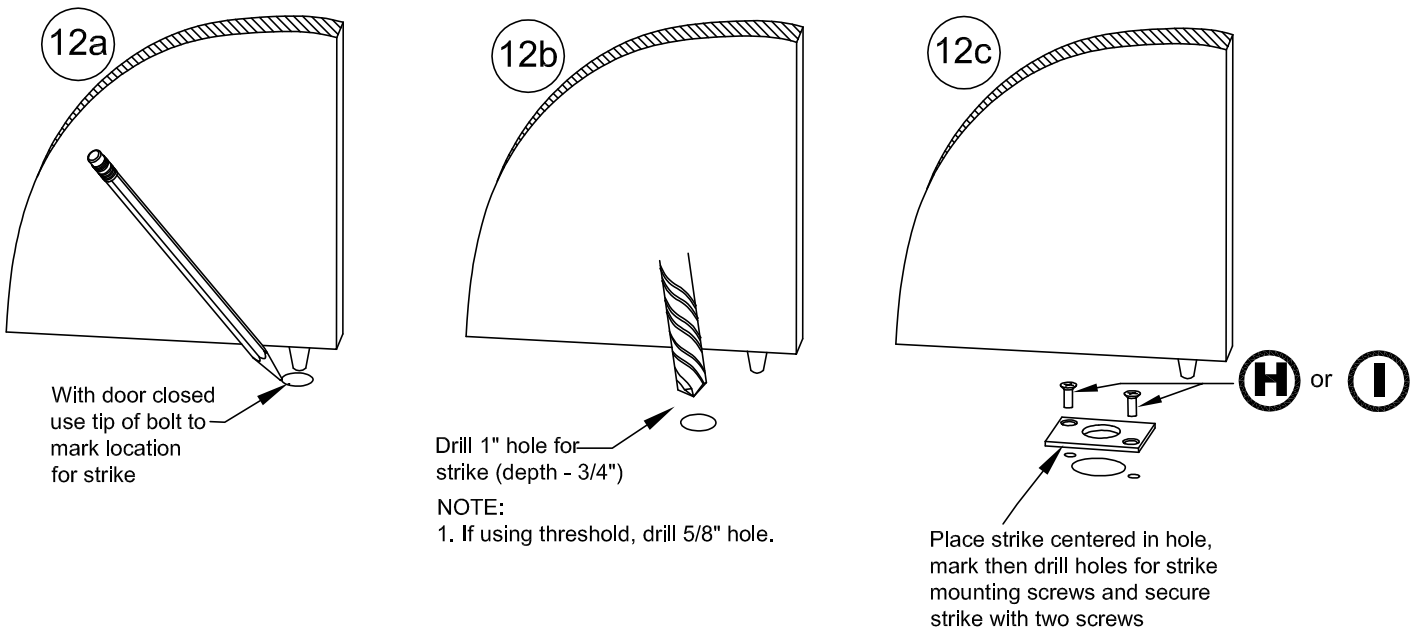

STEP 13: FINE LATCH ADJUSTMENT

13a. Ensure that latches are fully retracted. Gently close door. Latches should extend when door is closed.

13b. Depress pushpad and open door. Top latch should clear top strike & bottom bolt should not drag. Latches should remain in retracted position with pushpad released.

FINE LATCH ADJUSTMENT (if needed)

(± 3/8" adjustment possible on both top & bottom rods independently. See diagram below.)

13c. Top strike fine adjustment: Adjust strike engagement by either retaining or removing shim. Adjust door tightness by moving insert to desired position. Note that strike pocket can be flipped around to achieve additional adjustment (see step 11).

13d: **TOP LATCH ADJUSTMENT:** With latches extended, turn CCW until the top latchbolt projection begins to visually decrease, then turn CW until latchbolt projects fully. Rotate CW one additional full turn.

Top Adjustment

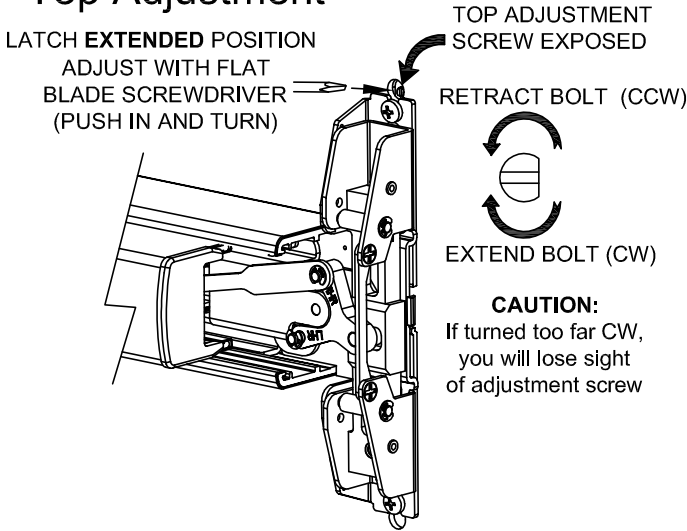

Bottom Adjustment

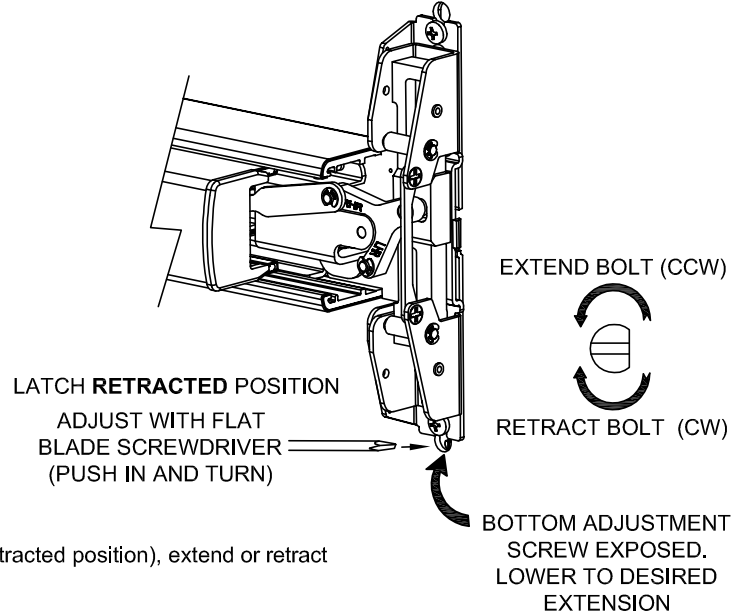

13e: **BOTTOM LATCH ADJUSTMENT:** With pushpad depressed (retracted position), extend or retract bottom bolt to desired engagement and clearance.

13f. Check device operation. Reference STEP 13a & 13b.

DEVICE OPERATION TROUBLESHOOTING

SYMPTOM	POSSIBLE CAUSE	SOLUTION
Device not latching when door closes	Bottom bolt is not properly aligned with bottom strike hole.	Modify bottom strike hole for fit.
	Top strike insert is not installed or not correctly aligned with the holdback.	Install and/or position strike insert per instructions.
	Through fasteners for trim (if applicable) are interfering with internal centerlift assembly.	Loosen and re-position through screws to clear.
	Rods improperly adjusted	Adjust rods per instructions. Remove device and re-install per instructions.
Latches release, but pushpad will not fully depress	Device centercase lift finger not inserted properly into centerlift assembly.	Remove device from backplate and re-install with lift finger correctly inserted.
	Top adjustment screw is adjusted too far in the retracted direction (CCW).	Rotate top adjustment screw in the extended direction (CW) per FINE LATCH ADJUSTMENT procedure.
Latches are not releasing when pushpad is fully depressed	Device centercase lift finger not inserted properly into centerlift assembly.	Remove device from backplate and re-install with lift finger correctly inserted.
	Top adjustment screw is adjusted too far in the extended direction (CW).	Rotate top adjustment screw in the retracted direction (CCW) per FINE LATCH ADJUSTMENT procedure.
	Bottom adjustment screw is adjusted too far in the extended direction (CCW).	Rotate bottom adjustment screw in the retracted direction (CW) per FINE LATCH ADJUSTMENT procedure.

STEP 14: COVER INSTALLATIONS

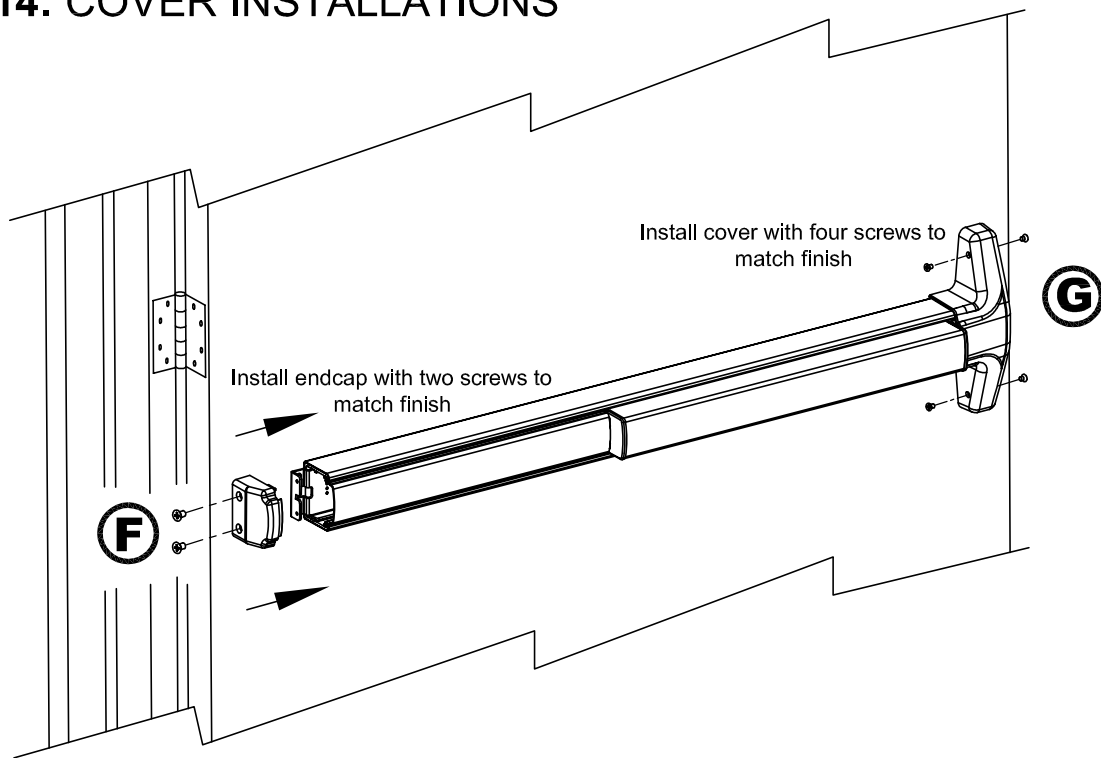

STEP 15: DOOR POPPER INSTALLATION

FIRE RATED TOP ROD ONLY (TRO) DOORS

A door locking popper is required when a fire door utilizes a top latching mechanism only (TRO). The popper is designed to project a spring loaded bolt into the adjacent frame or door in the event of fire. Detex recommends installing the popper in the edge of the door 12" above the threshold or finished floor.

Holes for the popper and plug must be aligned with each other.

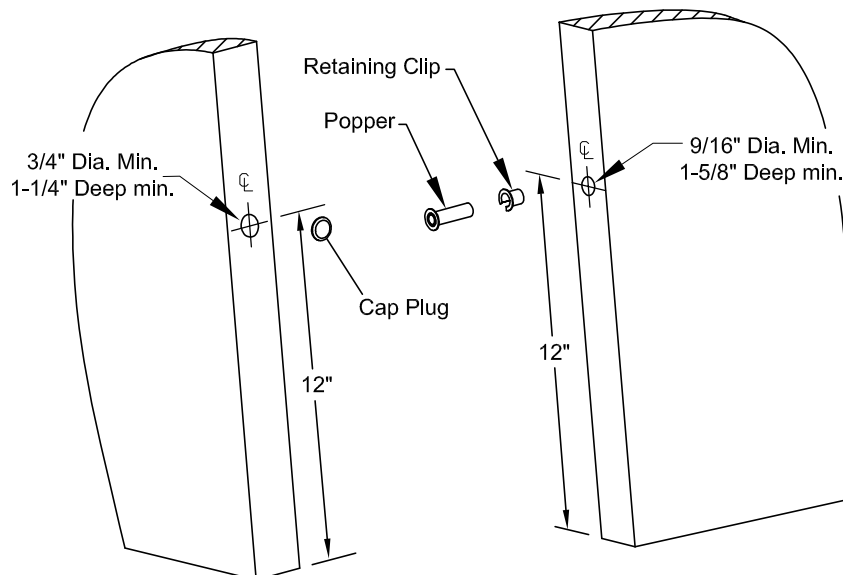

NOTE: Door/Frame reinforcement is required where popper and cap plug are to be installed.

Optional Accessories

Glass Bead Kit

Catalog No:

GB2 for EC1 endcap (p/n 101644)

GB18 for EC2 endcap (p/n 101644-1)

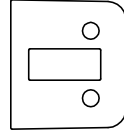
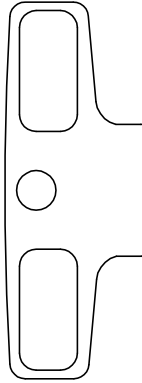

#1/4-20 X 1-1/2" Screws
Included

Sex Nut Kits

The #1/4-20 kits are available in 3 finishes:

Brushed Brass BHMA 606

Oil Rubbed Bronze BHMA 613

Stainless Steel BHMA 630

Catalog No: **SN4** (p/n: 105276-X) (supplied with screws)



Catalog No: **SN3** (p/n: 105274-X) (uses screws in hardware kit)

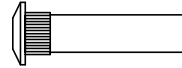

Tamper Kit

(Security Kit)

Catalog No:

SSK4 (p/n 101233-2 for top & bottom rod applications)

SSK5 (p/n 101233-3 for top rod only applications)

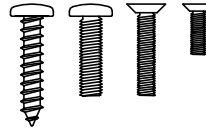

Security Screws

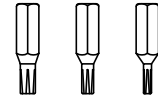

Security Pin TORX® Bits provided

Cylinder nut socket

p/n: 103779

