

## Motion Sensor Mini

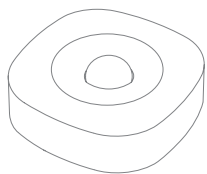

## INSTALLATION MANUAL

Version 1.1

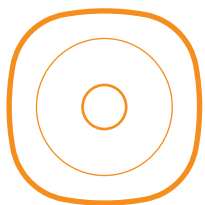

- Place the sensor free of curtains and other obstacles.
- Avoid placing the Motion Sensor Mini close to a heating/cooling source.
- Avoid placing the Motion Sensor Mini in direct sunlight or bright light.

### Mounting

#### MOUNTING FLAT ON CEILING OR WALL

1. Open the casing, and use the sensor part with oval holes to mark the screw holes on a ceiling or a wall.
2. Mount the sensor on the wall or the ceiling by installing one screw from the bag marked "A" through each oval hole.

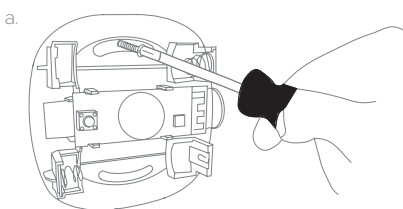

3. Alternatively, you can use the adhesive tape from bag "A" to mount the sensor.
4. Insert batteries and make sure that the battery polarity is correct (+/-).

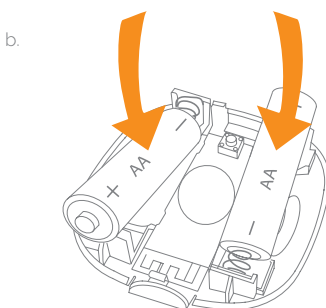

5. Close the casing of the sensor.

#### CORNER OR CEILING MOUNTING WITH BRACKET

1. If you have a sensor with a bracket included, you can mount the sensor with this bracket in a corner or on the ceiling.
2. Use the bracket to mark the screw holes on the two walls in the corner of the room or on the ceiling.
3. Use the two screws in the bag marked "A" to install the bracket in the marked place.

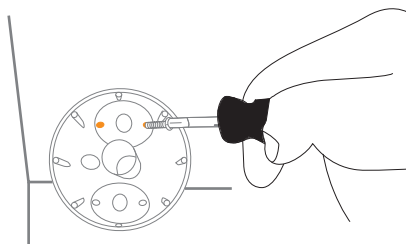
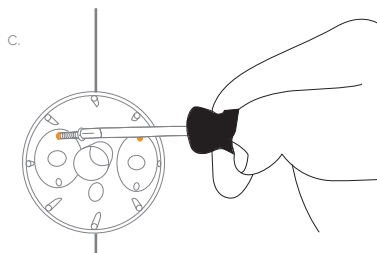

4. Alternatively, you can use the adhesive tape from bag "A" to mount the bracket.
5. Open the casing of the sensor.

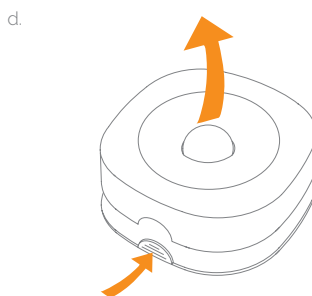

6. Place the part with oval holes against the already mounted bracket.

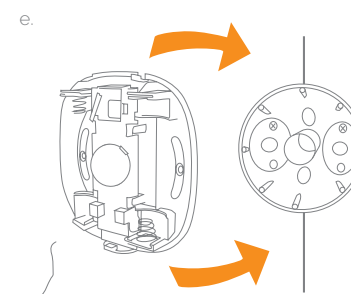

7. Take two screws from the bag marked "B". Mount one screw through each oval hole and into two holes on the bracket.

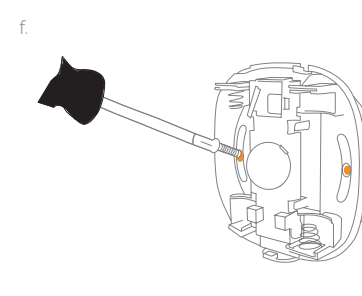

8. Insert batteries and make sure that the battery polarity is correct (+/-).
9. Close the casing of the sensor.

#### STAND

1. If you have a sensor with a plastic stand included, you can insert the stand in the opening on the back of the sensor as shown on the drawing.
2. Place the standing sensor on the shelf or on a desk.

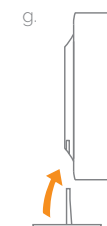

### Connecting

1. When batteries are inserted, the Motion Sensor Mini will automatically start searching (up to 15 minutes) for a Zigbee network to join.
2. Make sure that the Zigbee network is open for joining devices and will accept the Motion Sensor Mini.
3. While the sensor is searching for a Zigbee network to join, the LED flashes red.
4. When the sensor is connected to a network, it will stop flashing.

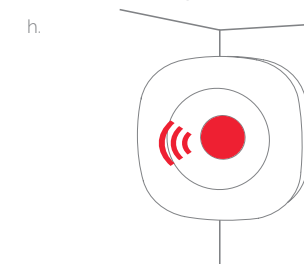

### Modes

#### SEARCHING GATEWAY MODE

Red LED light is flashing every second (up to 15 minutes).

#### ALARM TESTING MODE

The motion sensor will automatically flash green every time movement is detected by the Intruder Alarm System (IAS), no matter if the alarm system is activated or deactivated. The green flashes can help you determine if the placement of the sensor is suitable for alarm purposes.

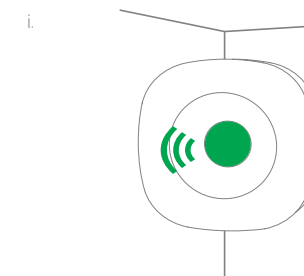

#### LOW BATTERY MODE

The device will flash red twice every minute when the battery is low.

### Product description

The compact Motion Sensor Mini allows the user to detect occupancy. With the Motion Sensor Mini, the user can set the light to turn on and off as people come and go. The motion sensor is PIR based and is able to sense movement up to 9 meters from the sensor.

Motion Sensor Mini includes two logical outputs - one with high sensitivity for occupancy and one with a lower sensitivity for alarm.

### Placement

- Place the sensor indoors at a temperature between 0-50°C.
- Its angle of detection from above, the sides, and below must be 45°.
- Place the Motion Sensor Mini in a location with a clear view of the monitored area and the windows.
- The distance from the sensor to a fireplace or a stove must be at least four meters.
- The Motion Sensor Mini must be reachable for battery testing and maintenance.

## Resetting

Resetting is needed if you want to connect your Motion Sensor Mini to another gateway, or if you need to perform a factory reset to eliminate abnormal behaviour.

### STEPS FOR RESETTING

1. Detach the sensor from the bracket and/or open the casing.
2. Check that the battery is inserted correctly.
3. Press and hold the round menu button inside the device.

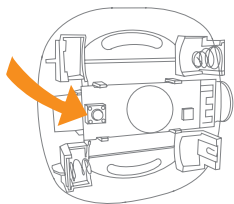

4. While you are holding the button down, the LED first flashes once, then two times in a row, and finally numerous times in a row.
5. Release the button while the LED is flashing numerous times in a row.
6. After you release the button, the LED shows one long flash, and the reset is completed.

## Fault finding

- In case of a bad or weak signal, change the location of the Motion Sensor Mini. Otherwise, you can relocate your gateway or strengthen the signal with a smart plug.
- If the search for a gateway has timed out, a short press on the button will restart it.

## Battery replacement

The device will blink twice every minute when the battery is low.

**CAUTION: RISK OF EXPLOSION IF BATTERIES ARE REPLACED BY AN INCORRECT TYPE. DISPOSE OF THE BATTERIES IN ACCORDANCE WITH INSTRUCTIONS.**

**CAUTION:** When removing cover for battery change - Electrostatic Discharge (ESD) can harm electronic components inside

1. To replace the battery, detach the Motion Sensor Mini from the bracket and/or open the casing.
2. Replace the battery respecting the polarities.

k.

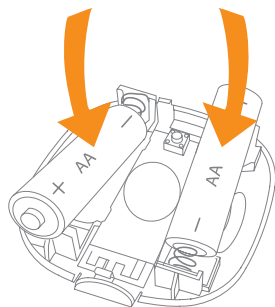

3. Close the casing of the sensor.

## Disposal

Dispose the product and battery properly at the end of their lives. This is electronic waste, which should be recycled.

## FCC statement

Changes or modifications to the equipment not expressly approved by the party responsible for compliance could void the user's authority to operate the equipment.

**NOTE:** This equipment has been tested and found to comply with the limits for a Class B digital device, pursuant to Part 15 of the FCC Rules. These limits are designed to provide reasonable protection against harmful interference in a residential installation. This equipment generates, uses and can radiate radio frequency energy and, if not installed and used in accordance with the instructions, may cause harmful interference to radio communications. However, there is no guarantee that interference will not occur in a particular installation.

If this equipment does cause harmful interference to radio or television reception, which can be determined by turning the equipment off and on, the user is encouraged to try to correct the interference by one or more of the following measures:

- Reorient or relocate the receiving antenna.
- Increase the separation between the equipment and receiver.
- Connect the equipment into an outlet on a circuit different from that to which the receiver is connected.
- Consult the dealer or an experienced radio/TV technician for help.

This device complies with FCC RF radiation exposure limits set forth for an uncontrolled environment. The antenna used for this transmitter must be installed to provide a separation distance of at least 20 cm from all persons and must not be co-located or operating in conjunction with any other antenna or transmitter.

This device complies with part 15 of the FCC Rules. Operation is subject to the following two conditions:

1. This device may not cause harmful interference, and
2. This device must accept any interference received, including interference that may cause undesired operation.

## CE certification

The CE mark affixed to this product confirms its compliance with the European Directives which apply to the product and, in particular, its compliance with the harmonized standards and specifications.



### IN ACCORDANCE WITH THE DIRECTIVES

- Radio Equipment Directive (RED) 2014/53/EU
- EMC Directive 2014/30/EU
- RoHS Directive 2015/863/EU amending 2011/65/EU
- REACH 1907/2006/EU + 2016/1688

### Other certifications

- Zigbee Home Automation 1.2 certified.



### All rights reserved.

Develco Products assumes no responsibility for any errors, which may appear in this manual. Furthermore, Develco Products reserves the right to alter the hardware, software, and/or specifications detailed herein at any time without notice, and Develco Products does not make any commitment to update the information contained herein. All the trademarks listed herein are owned by their respective owners.

Distributed by Develco Products A/S  
Tangen 6  
8200 Aarhus N  
Denmark  
[www.develcoproducts.com](http://www.develcoproducts.com)

