

Control unit 300 Series

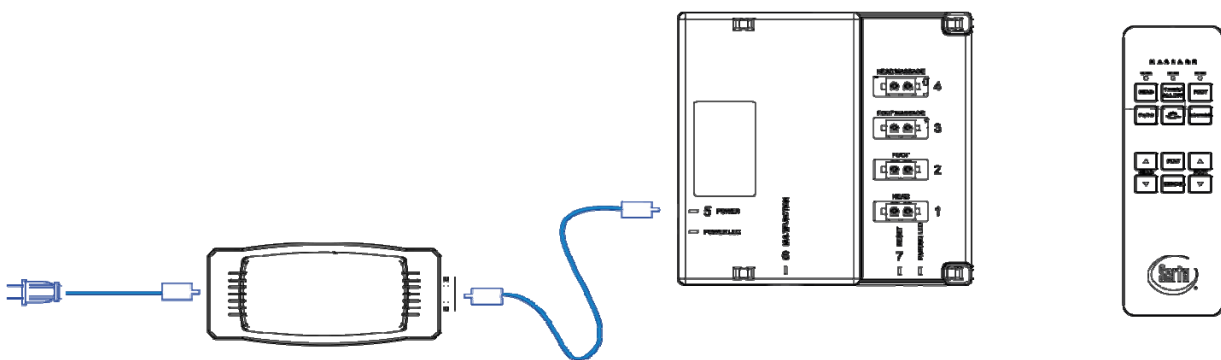

mounting + operating

1 Overview

This control unit is designated to operate an electrically driven bed with optional comfort functions.

- Power supply is provided via SMPS so the control box has protection class III.
- The system is operated with an RF remote. The RF receiver is integrated into the control unit.

Bed view from beneath

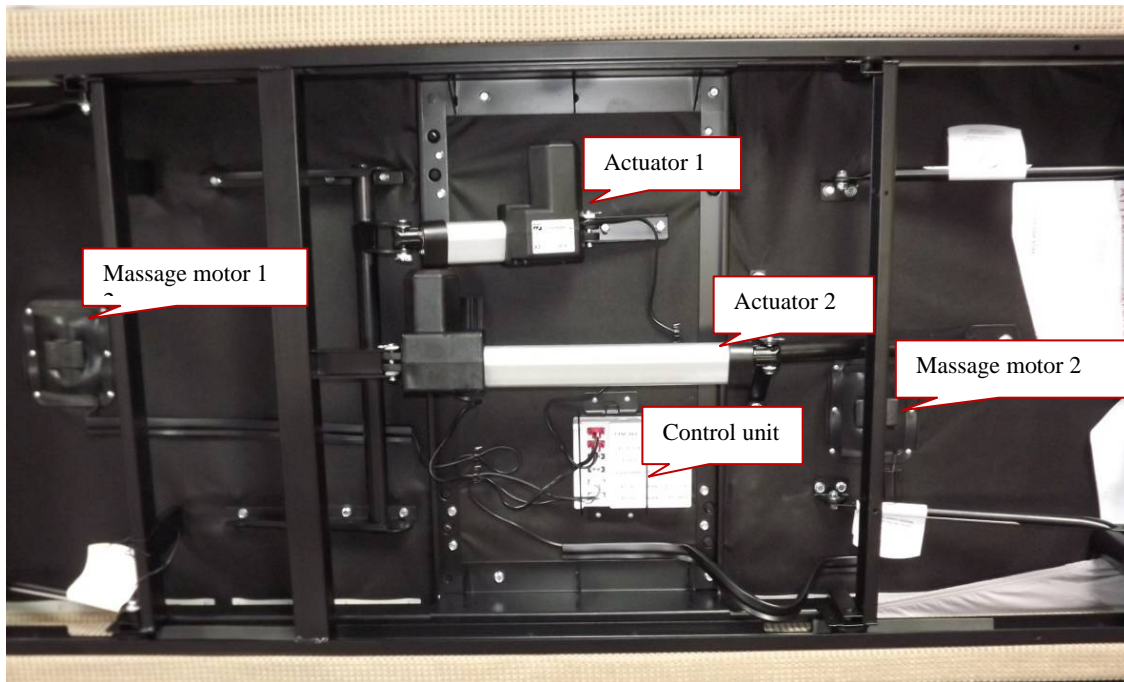

Here for example you can see a control unit with two actuators and two massage motors connected

Control Unit 258-2
CU258-2

2 Mounting the control unit

This mounting bracket is fixed on the flipside of the bed

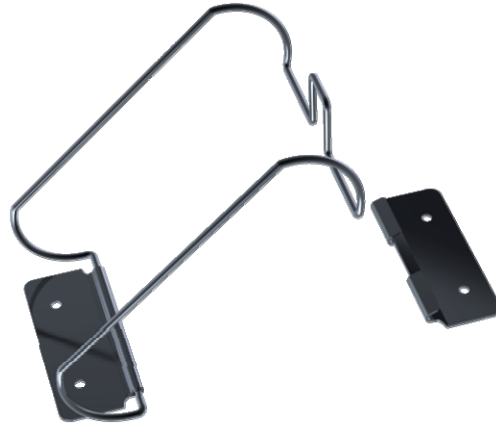

These two bolts fix the position of the control unit between the mounting bracket.

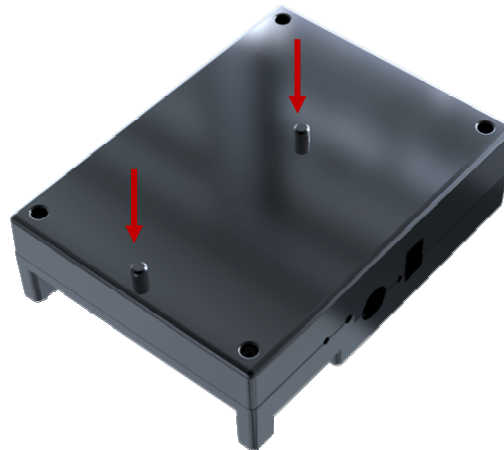

The clip snaps in the holding fixtures of the control unit

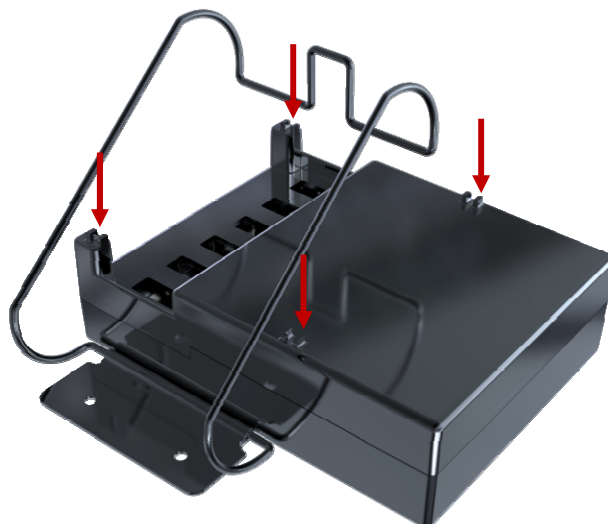

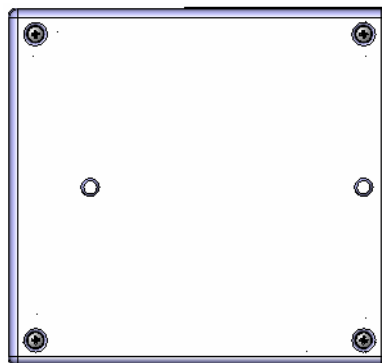
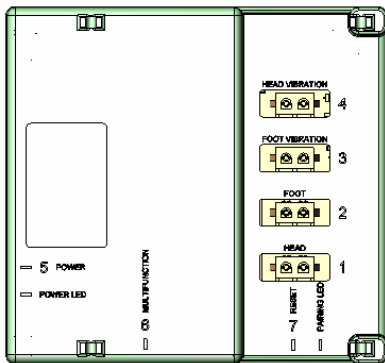
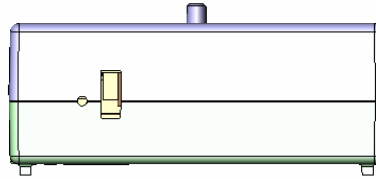
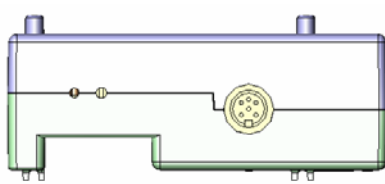
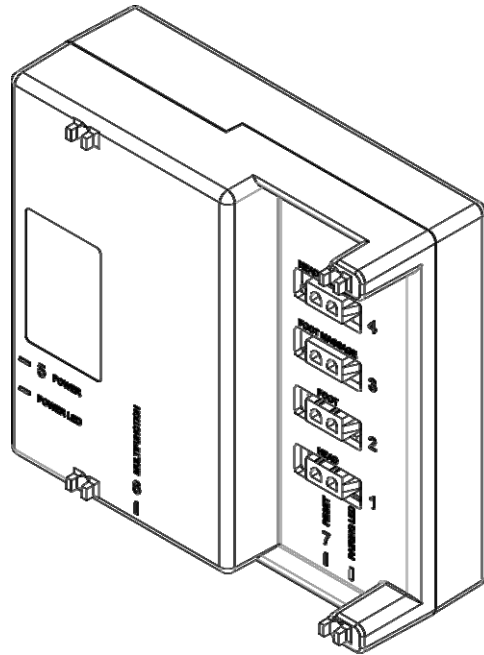

Performance data control unit	
Duty cycle	2/18 min. or 10 %, max, 5 switching cycles per minute
Output voltage	29 V / 6A
Further features	
Housing colour	black RAL 9005
Housing material	ABS + PC
Ports	drives: 2 actuators / 2 vibration motors power input 1 / multifunction output 1
Indicators + buttons	Reset + pairing button / Pairing LED for RF Power LED
Protection type	IP20
Protection class	III
Relative humidity	30% - 75%
Ambient temperature	+50°F - +104°F
Power supply	external

Integrated RF receiver

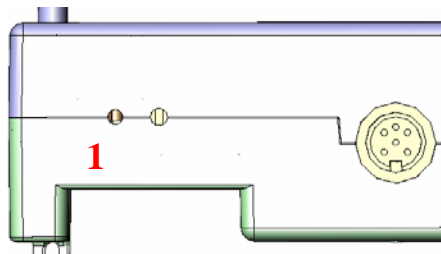

Key	Function
1	Pairing enable

Performance data RF receiver	
modulation	GFSK
Frequency Range	2.403~2.480GHz
Transmitted Power	0 dBm
Battery	30V supply voltage
Working Current	<60mA
Standby Current	<20mA
Ambient Temperature	-40—85°C
PCB Material & Size	FR4 1.6mm 120*120mm

2.1 Power supply PD12 65444

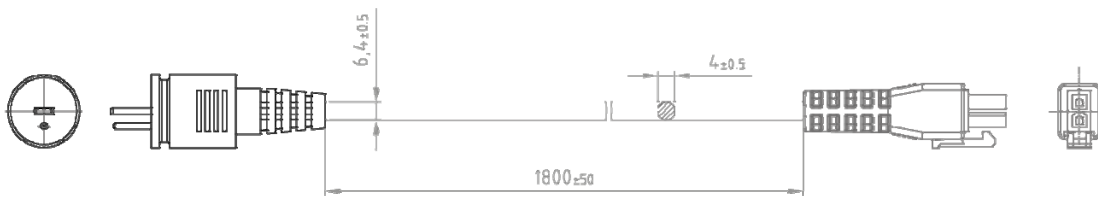
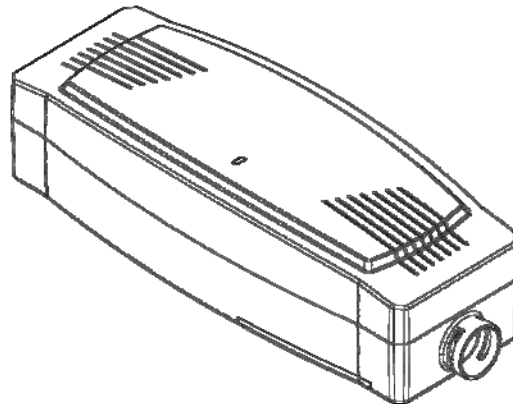

Connecting cable 73178 to control box

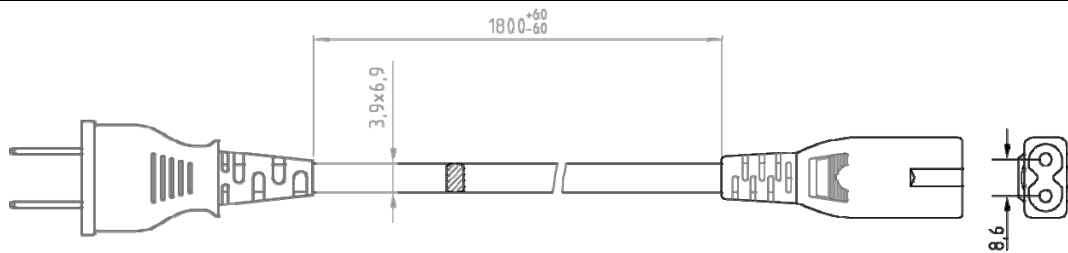

Power supply cable 3.00.401.151.30 to mains power

Performance data

Output voltage	29 V DC constant voltage output
Components	
Indicators	LED operating status indication (green)
Colour	black RAL 9005
Further data	
Protection type	IP20
Protection class	II
Relative humidity	30% - 75%
Ambient temperature	+50°F - +104°F
Power supply	wide input voltage range 100-240 V AC
Safety	NTC temperature sensor, primary fuse, overload protection, overcurrent switch-off, short-circuit-proof output

Remote Control 258B

2.2 RF258B

Frontside

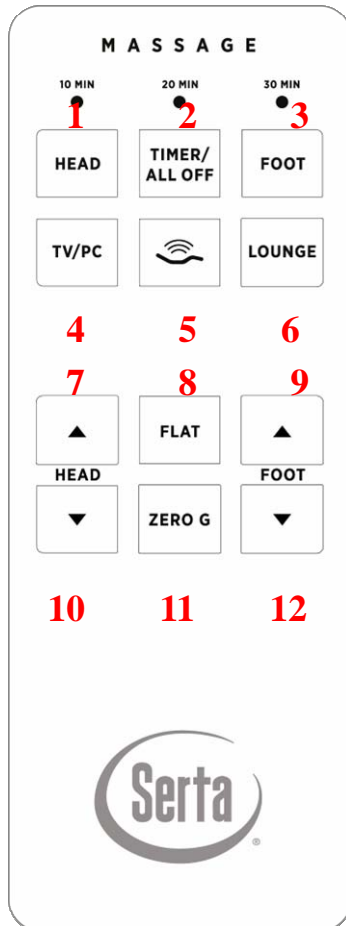

Keys for fixed positions



Choose between comfortable positions

Manual adjustment keys



Move head & foot rest up and down manually

Message keys



- ▶ With the timer key you program duration and stop the massage function.
- ▶ The LEDs signal the programmed duration, the key below starts the massage. With the Head & Foot keys you can select the massage zones.

Pairing button & battery box (flipside)

Insert 3x AAA

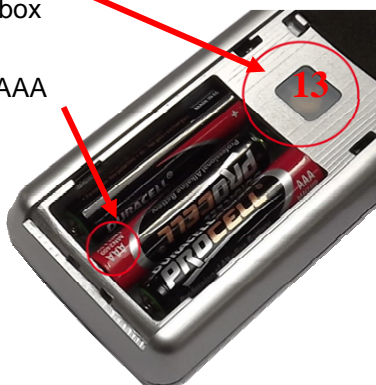

Key	Function
1	Massage Head ON
2	Adjust Massage timer
3	Massage Foot ON
4	Move bed in TV position
5	Start both Massage (Head and Foot)
6	Move bed in Lounge position
7	Relay 1 on
8	Move bed in Flat position
9	Relay 3 on
10	Relay 2 on
11	Move bed in Zero G position
12	Relay 4 on
13	Pairing

Performance data remote (RF transmitter)	
Modulation	GFSK
Frequency Range	2.403~2.480GHz
Battery	AAA
Working Current	<40mA
Standby Current	<8uA
Ambient Temperature	-40—85°C
RC Dimension	145*50*14mm
PCB Material & Size	FR4 1.6mm 79*42mm
Housing Material	ABS+PC

4 Functional Description

Take cable 3.00.401.151.30 and connect it to mains supply.

The system is delivered paired!

You can test the functions of the system with the RF remote.

Pairing instruction (in case of trouble)

Pairing the remote with the control box.

The distance between remote and control box for pairing should be less than 2 meters!

1. Remove the battery cover on the flipside of the remote.
2. Insert/check existing 3x AAA batteries.
3. Push the reset button on the control box twice with something spiky.
The green pairing LED adjoining is lit.

Now you have 10 s to pair remote and receiver.

4. On the flipside of the remote is a silicone push button positioned above the batteries (13).
A blue LED starts blinking as the button is pressed.
Keep it pressed until the blue LED is lit continuously, then pairing is completed, the blue LED light fades away.

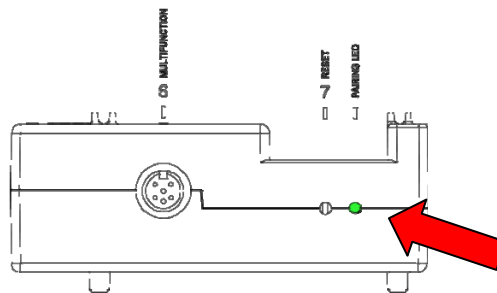

This device complies with Industry Canada licence-

exempt RSS standard(s). Operation is subject

to the following two conditions: (1) this device may not cause interference, and (2) this device must accept any interference, including interference that may cause undesired operation of the device.

2. Changes or modifications not expressly approved by the party responsible for compliance could void the user's authority to operate the equipment.

The users manual or instruction manual for an intentional or unintentional radiator shall caution the user that changes or modifications not expressly approved by the party responsible for compliance could void the user's authority to operate the equipment. In cases where the manual is provided only in a form other than paper, such as on a computer disk or over the Internet, the information required by this section may be included in the manual in that alternative form, provided the user can reasonably be expected to have the capability to access information in that form.

Le présent appareil est conforme aux CNR d'Industrie Canada applicables aux appareils radio exempts de licence. L'exploitation est autorisée aux deux conditions suivantes : (1) l'appareil ne doit pas produire de brouillage, et (2) l'utilisateur de l'appareil doit accepter tout brouillage radioélectrique subi, même si le brouillage est susceptible d'en compromettre le fonctionnement."

RSS-102 Statement: This equipment complies with Industry Canada radiation exposure limits set forth for an uncontrolled environment.

Déclaration CNR-102: Cet équipement est conforme à l'exposition aux rayonnements Industry Canada limites établies pour un environnement non contrôlé.

FCC Warning:

- This device complies with Part 15 of the FCC Rules. Operation is subject to the following two conditions:
 - (1) this device may not cause harmful interference, and
 - (2) this device must accept any interference received, including interference that may cause undesired operation.
- Changes or modifications not expressly approved by the party responsible for compliance could void the user's authority to operate the equipment.
- NOTE: This equipment has been tested and found to comply with the limits for a Class B digital device, pursuant to Part 15 of the FCC Rules. These limits are designed to provide reasonable protection against harmful interference in a residential installation. This equipment generates, uses and can radiate radio frequency energy and, if not installed and used in accordance with the instructions, may cause harmful interference to radio communications. However, there is no guarantee that interference will not occur in a particular installation. If this equipment does cause harmful interference to radio or television reception, which can be determined by turning the equipment off and on, the user is encouraged to try to correct the interference by one or more of the following measures:
 - -- Reorient or relocate the receiving antenna.
 - -- Increase the separation between the equipment and receiver.
 - -- Connect the equipment into an outlet on a circuit different from that to which the receiver is connected.
 - -- Consult the dealer or an experienced radio/TV technician for help.