

Dfine	
Building A2, Tianfu Software Park, Hi-tech Zone South Extension of Tianfu Wide Road Chengdu China	
Title MAIN	
Size A3	Document Number 2431.01-JD7.820.271
Date: Tuesday, July 27, 2010	Sheet 1 of 11
Rev 1.0	

Dfine

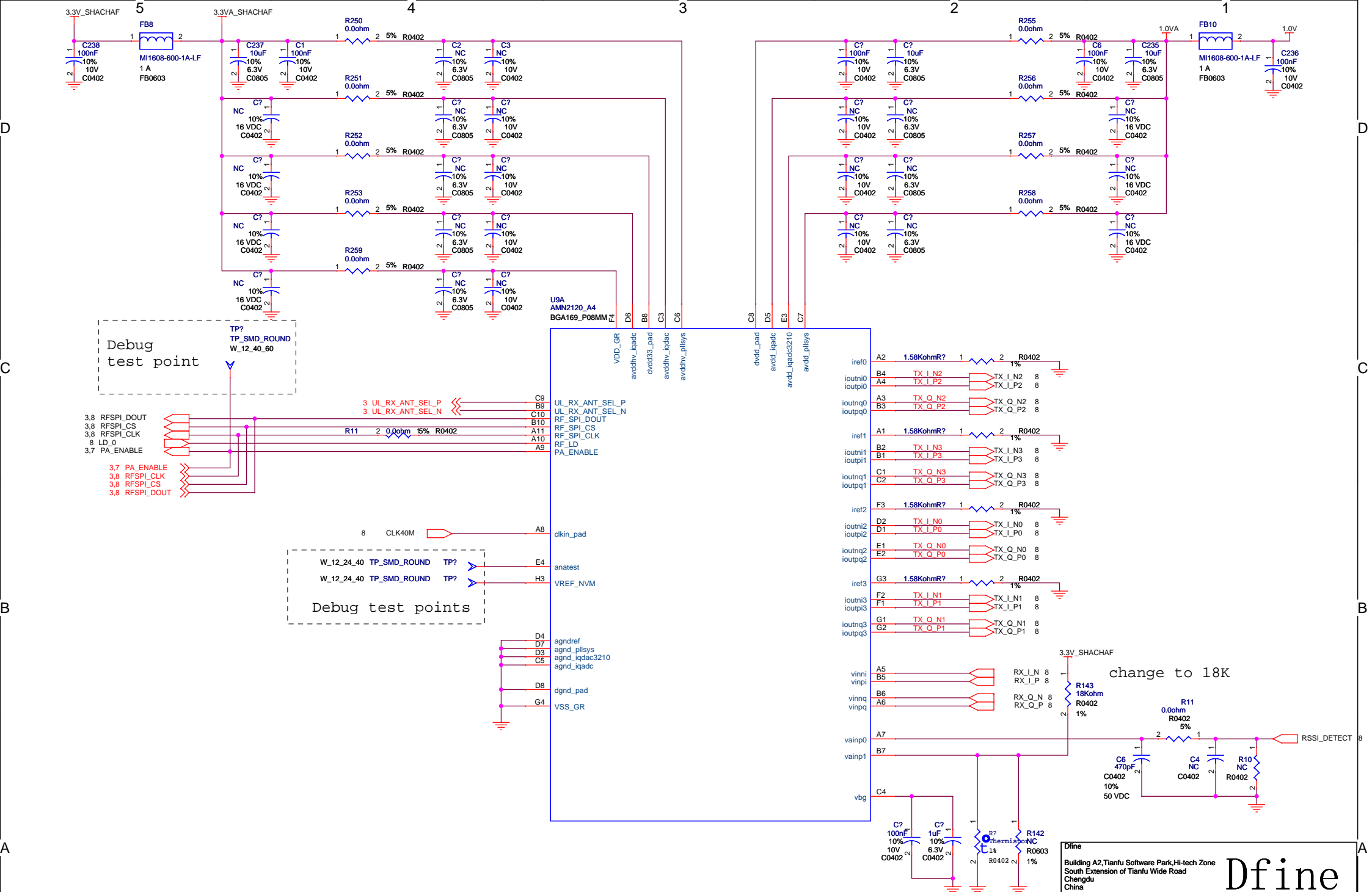

Dfine		
Building A2, Tianfu Software Park, Hi-tech Zone South Extension of Tianfu Wide Road Chengdu China		
Dfine		
Title SHACHAF AFE		
Size A3	Document Number 2431.01-JD7.820.271	Rev 1.0
Date: Tuesday, July 27, 2010	Sheet 2	of 11

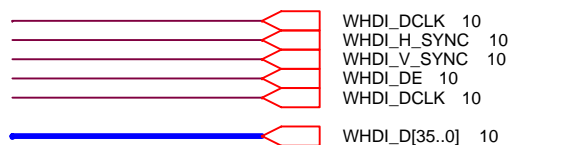
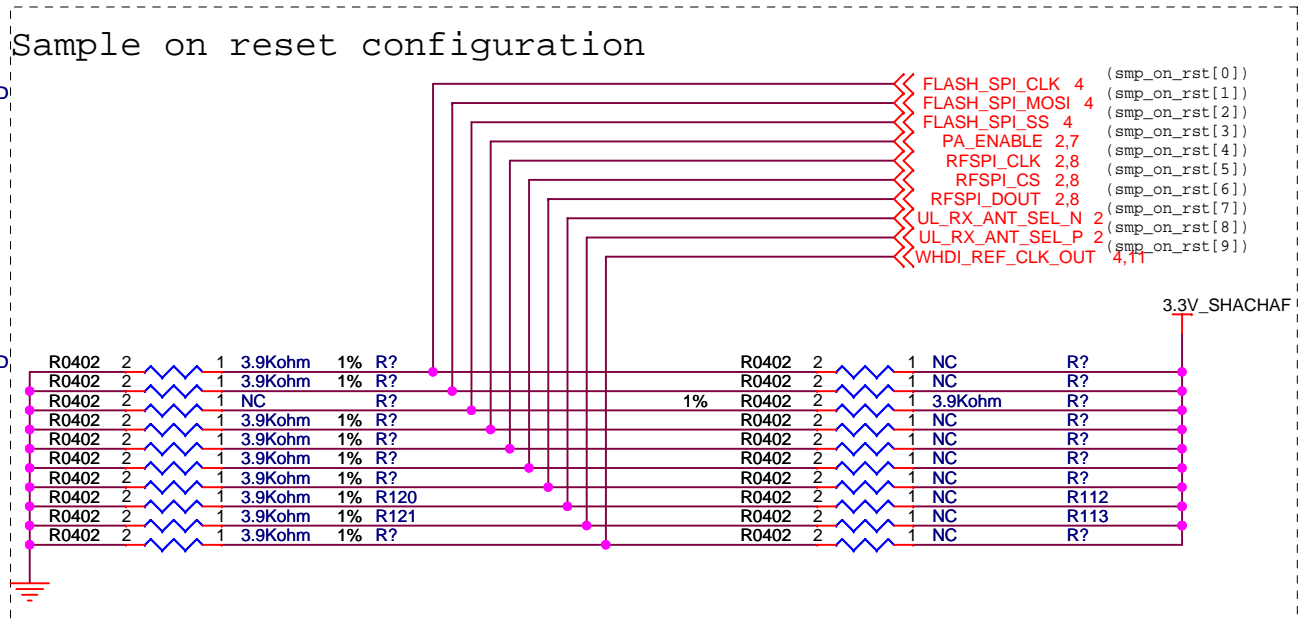
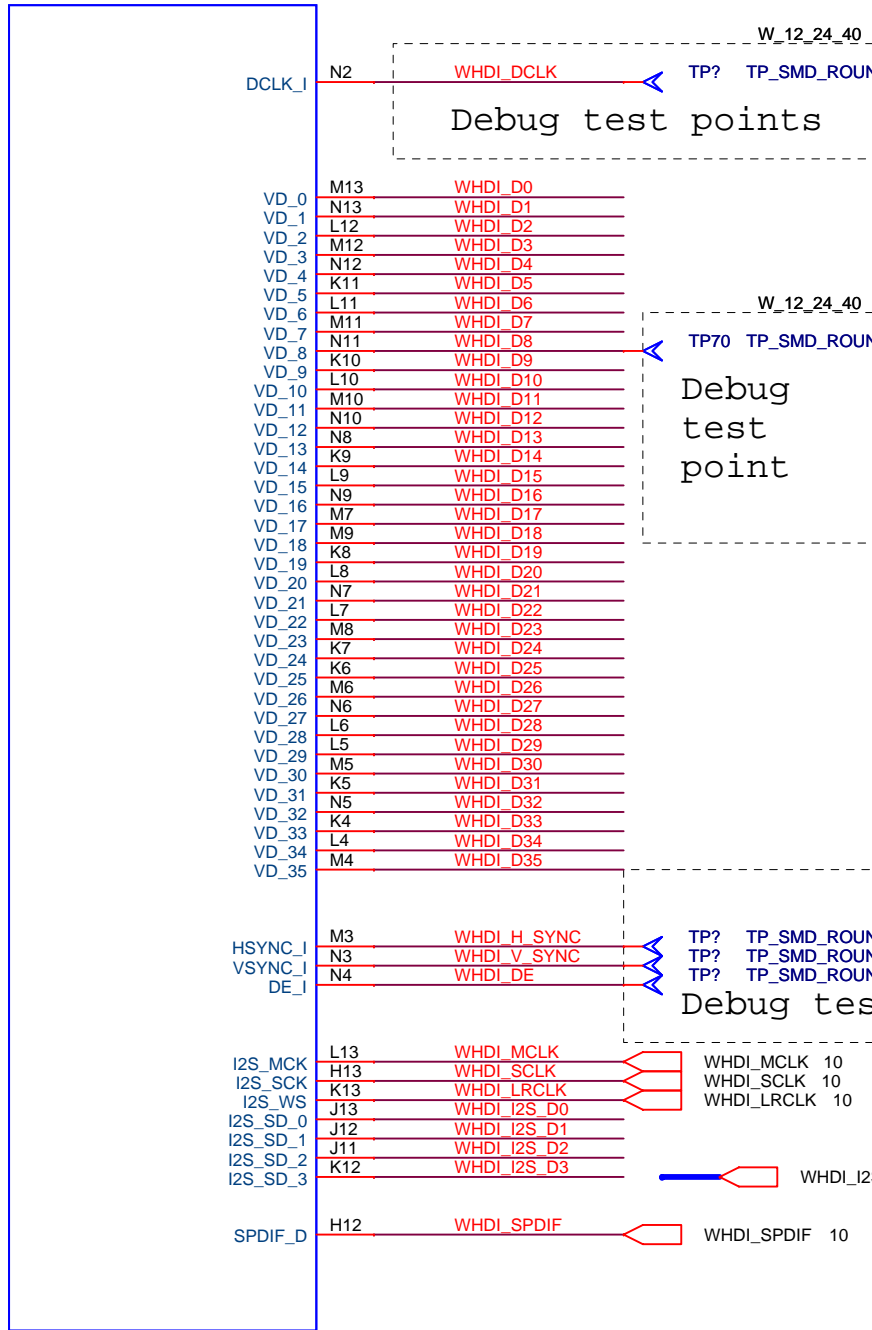

Dfine		
Building A2, Tianfu Software Park, Hi-tech Zone South Extension of Tianfu Wide Road Chengdu China		
<h1>Dfine</h1>		
Title SHACHAF AV		
Size A4	Document Number 2431.01-JD7.820.271	Rev 1.0
Date: Monday, October 18, 2010	Sheet 3	of 11

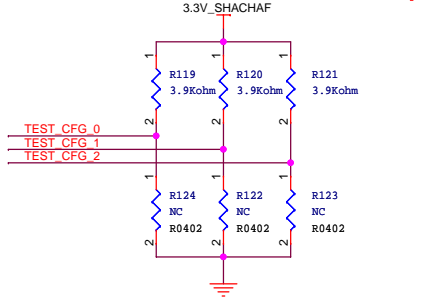
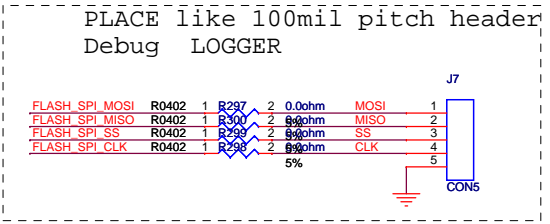
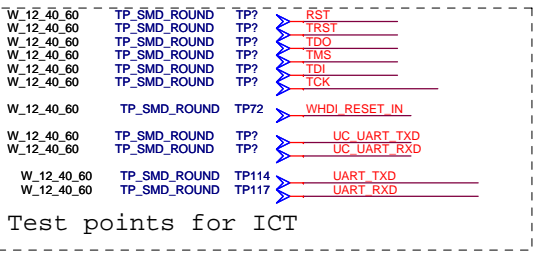
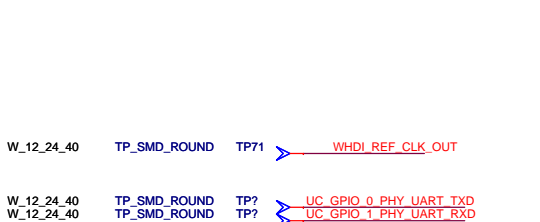
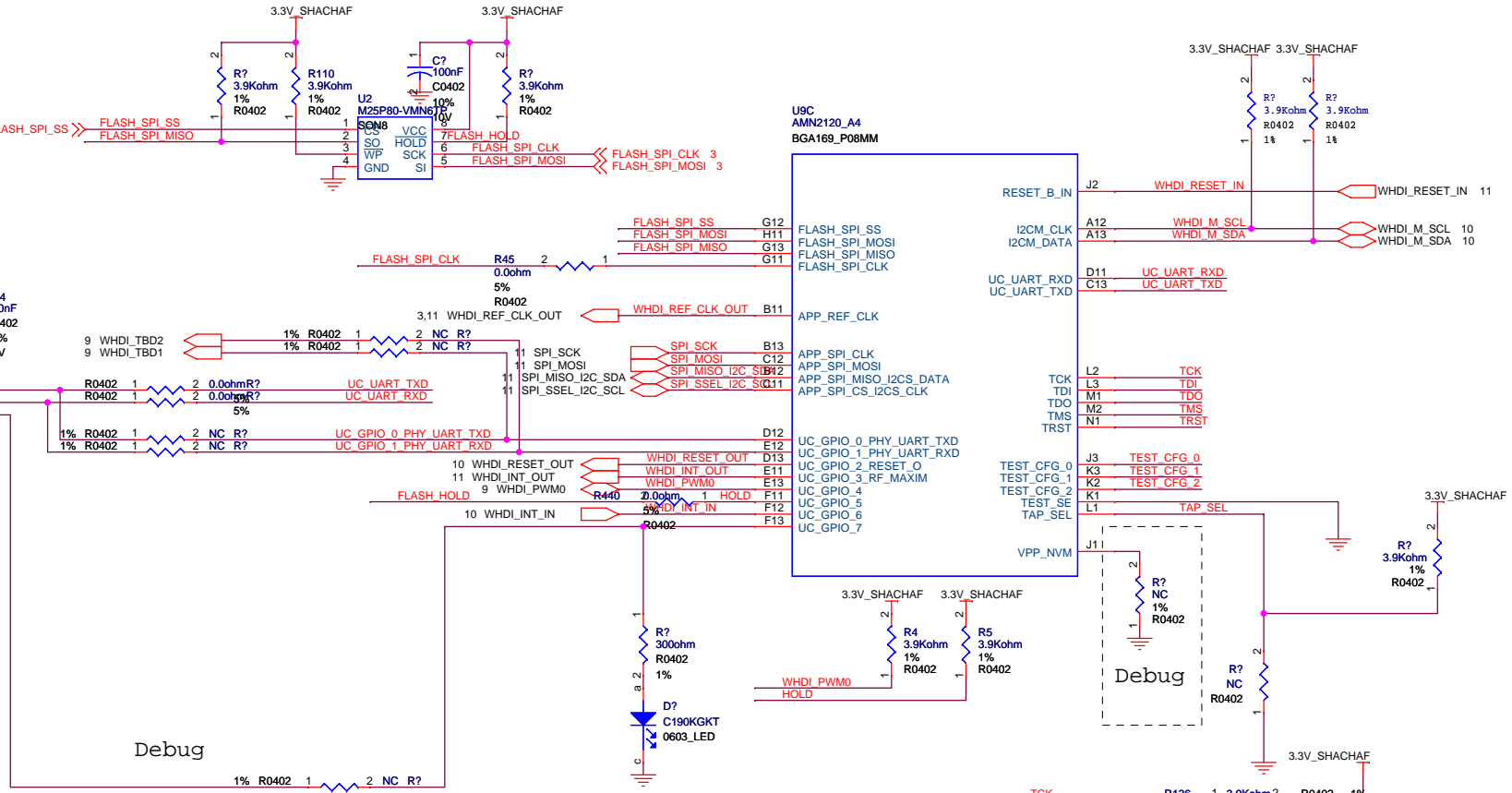
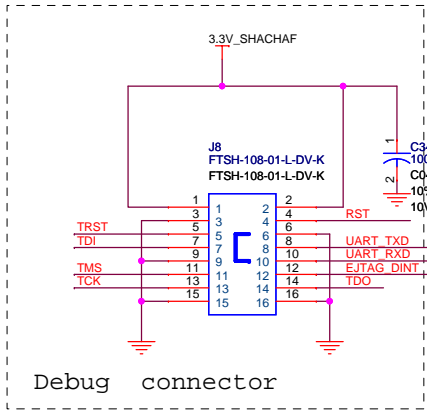

Dfine			
Building A2, Tianfu Software Park, Hi-tech Zone South Extension of Tianfu Wide Road Chengdu China			
Title SHACHAF DEBUG			
Size A3	Document Number 2431.01-JD7.820.271	Rev 1.0	
Date: Tuesday, July 27, 2010	Sheet 4	of 11	

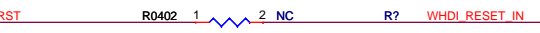

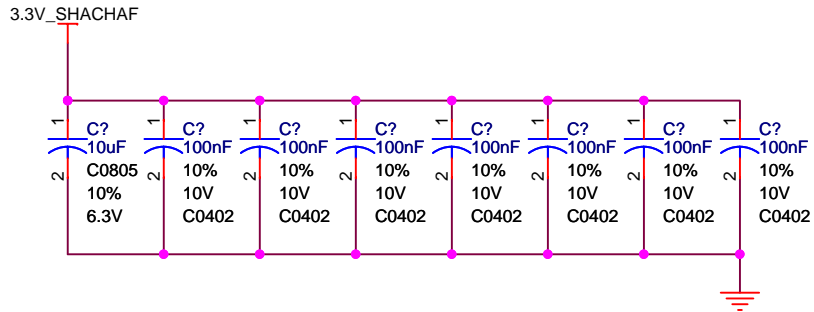
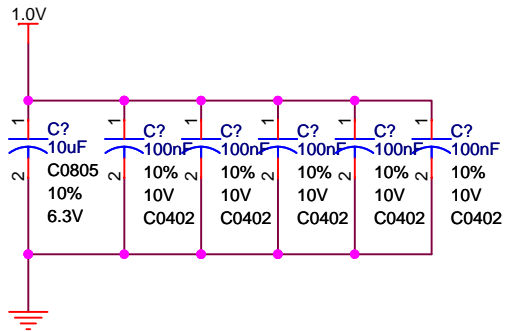
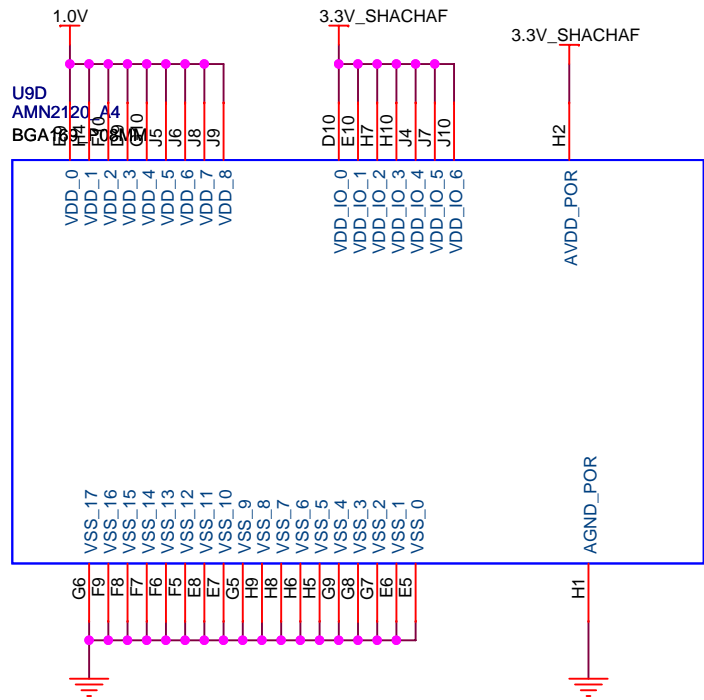

Dfine		
Building A2,Tianfu Software Park,Hi-tech Zone South Extension of Tianfu Wide Road Chengdu China		
<h1>Dfine</h1>		
Title SHACHAF POWER		
Size A4	Document Number 2431.01-JD7.820.271	Rev 1.0
Date: Tuesday, July 27, 2010	Sheet 5	of 11

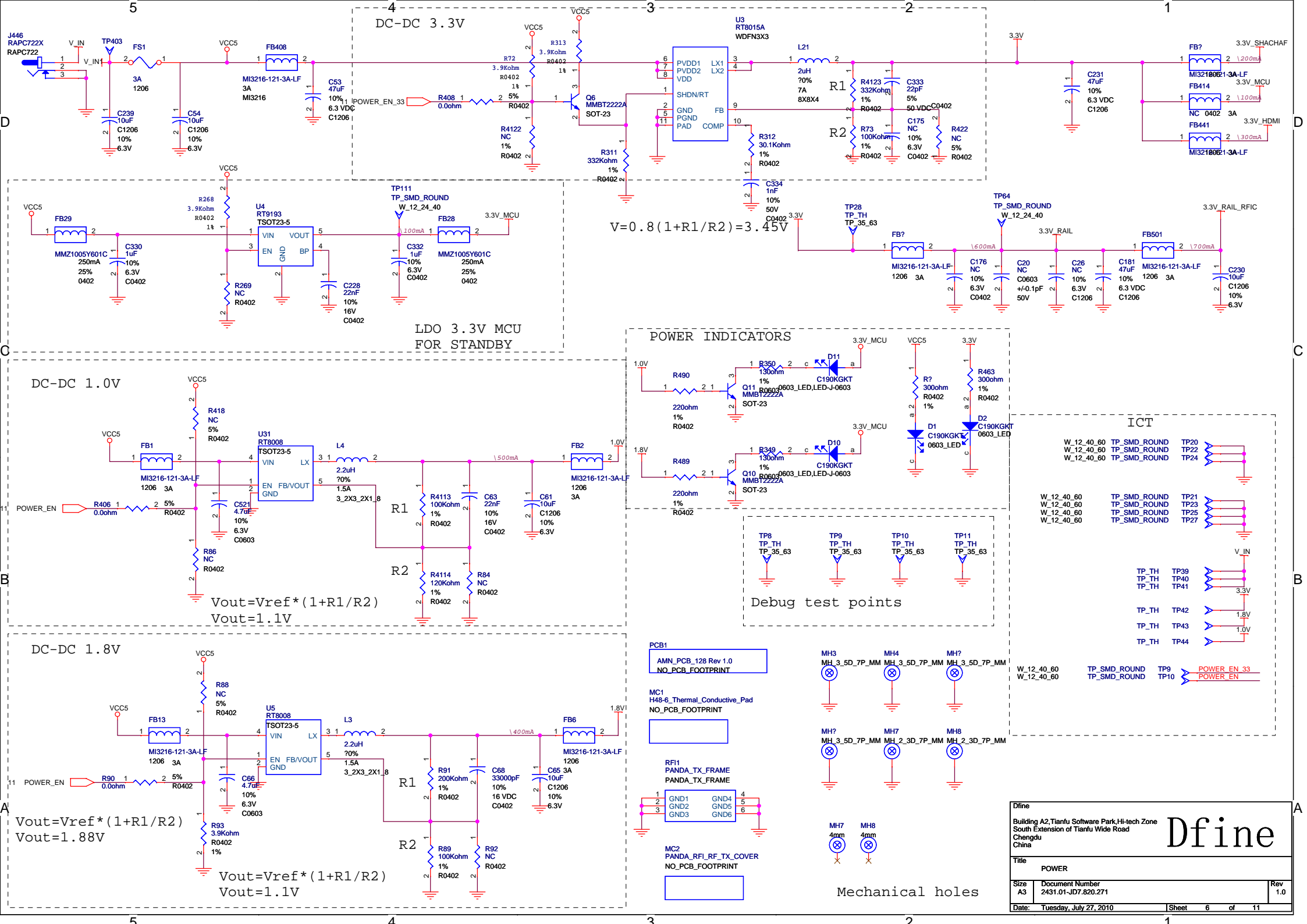

DC-DC 3.3V

$$V = 0.8(1 + R1/R2) = 3.45V$$

LDO 3.3V MCU FOR STANDBY

POWER INDICATORS

ICT

Debug test points

DC-DC 1.0V

DC-DC 1.8V

$$V_{out} = V_{ref} * (1 + R1/R2)$$

$$V_{out} = 1.1V$$

$$V_{out} = V_{ref} * (1 + R1/R2)$$

$$V_{out} = 1.1V$$

PCB1
AMN_PCB_128 Rev 1.0
NO_PCB_FOOTPRINT

MC1
H48-6_Thermal_Conductive_Pad
NO_PCB_FOOTPRINT

RF1
PANDA_TX_FRAME
PANDA_TX_FRAME

MC2
PANDA_RFI_RF_TX_COVER
NO_PCB_FOOTPRINT

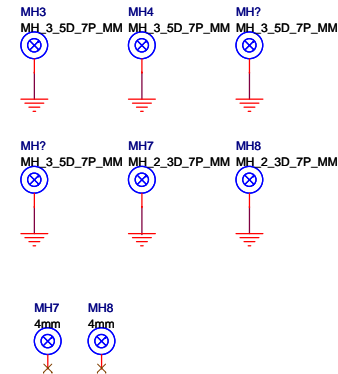

Mechanical holes

Dfine		
Building A2, Tianfu Software Park, Hi-tech Zone South Extension of Tianfu Wide Road Chengdu China		
Title	POWER	
Size	Document Number	Rev
A3	2431.01-JD7.820.271	1.0
Date:	Tuesday, July 27, 2010	Sheet 6 of 11

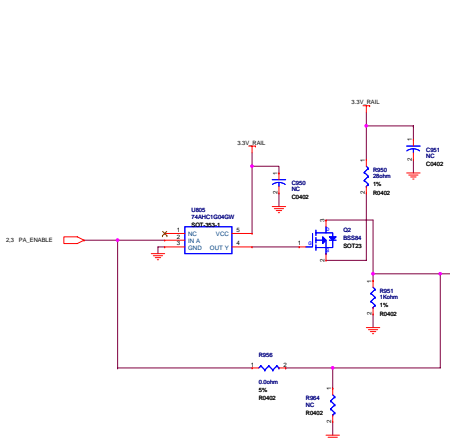

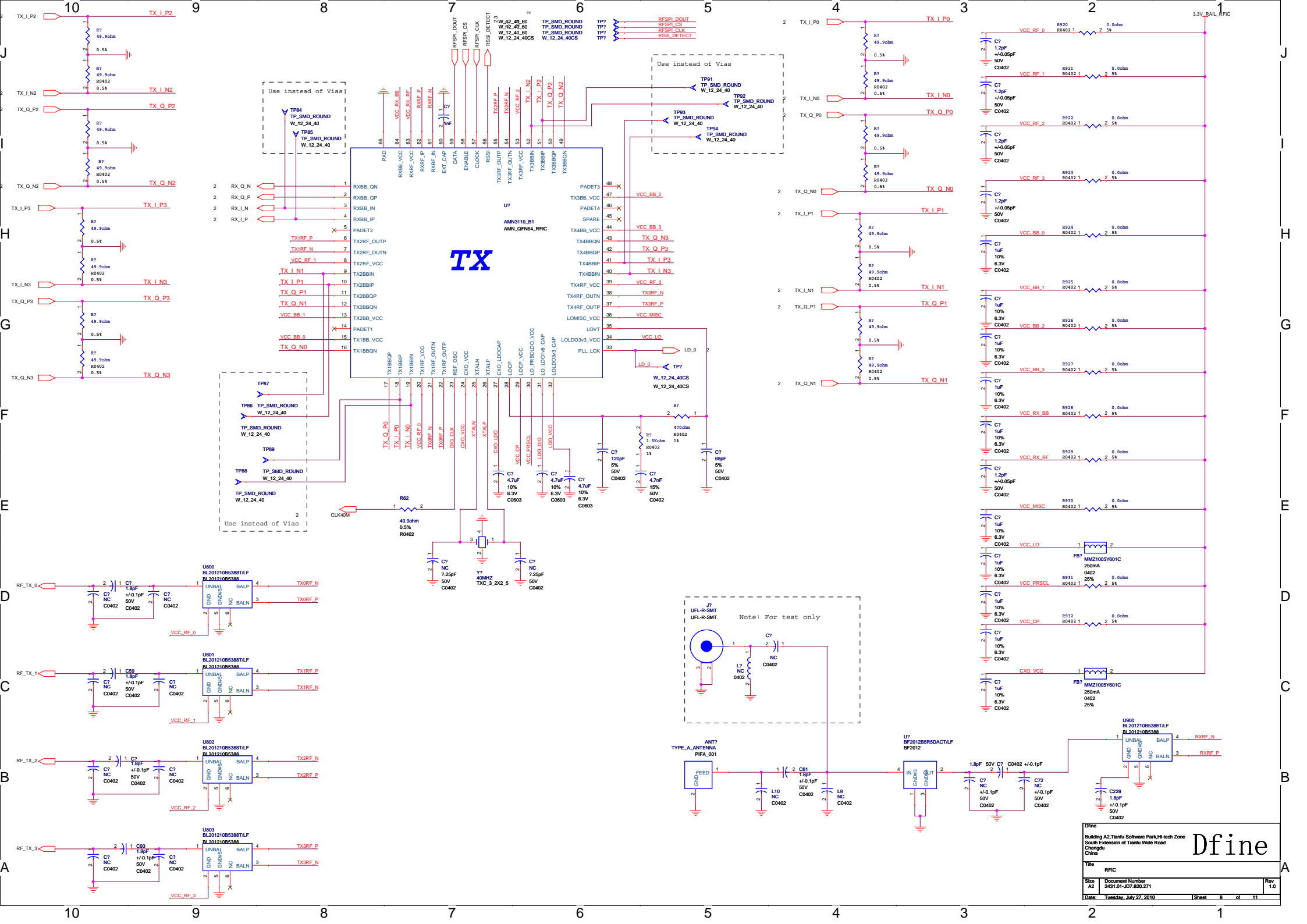

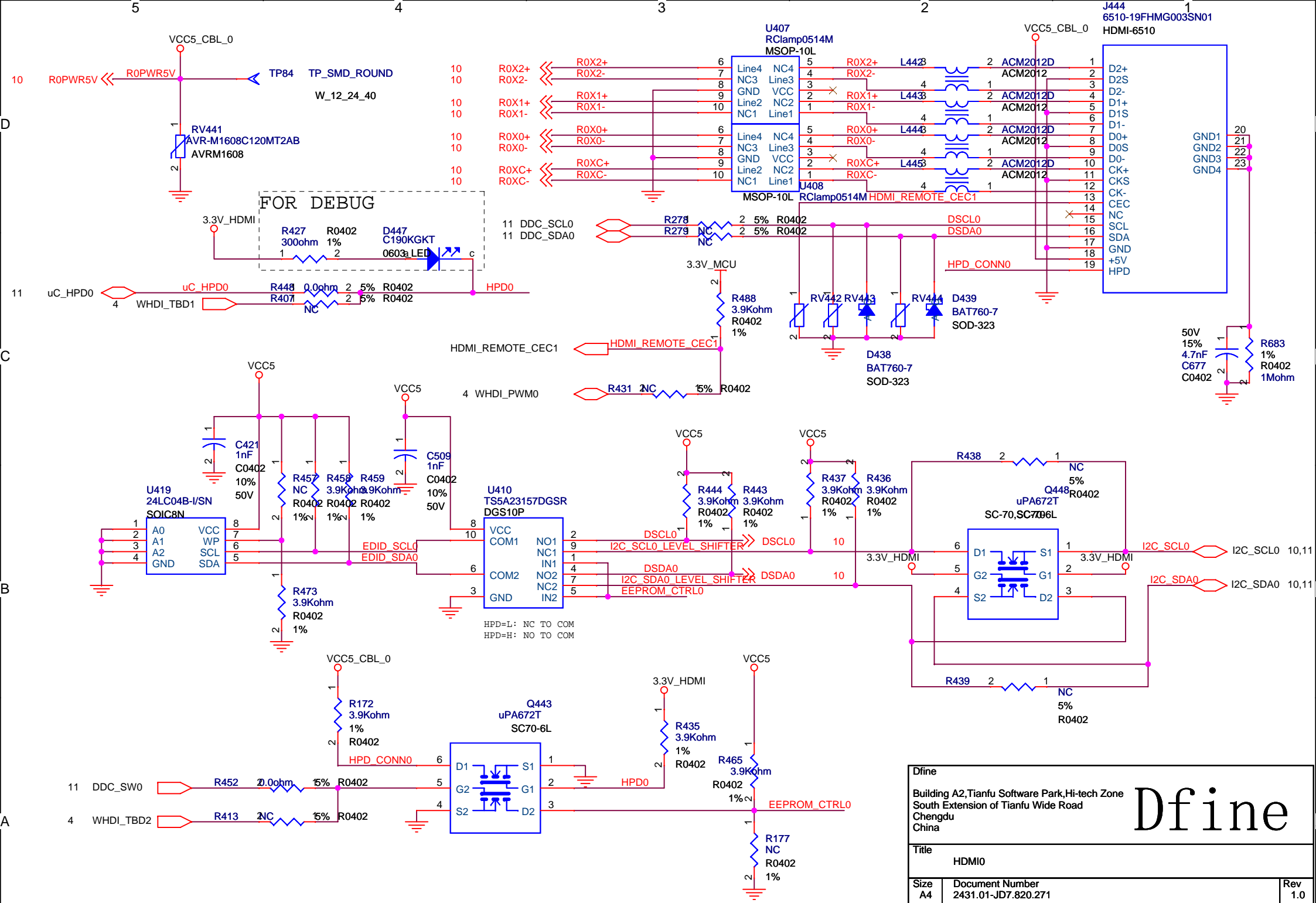

Dfine		
Building A2, Tianfu Software Park, Hi-tech Zone South Extension of Tianfu Wide Road Chengdu China		
Dfine		
Title HDMI0		
Size A4	Document Number 2431.01-JD7.820.271	Rev 1.0
Date: Tuesday, July 27, 2010	Sheet 9	of 11

Ref	SiI9135	CAT6023	Pin
R71	NC	499R	55
R70	NC	4.7Kohm	98
Y	28.322MHz	27MHz	94/95
R72	NC	4.7Kohm	99

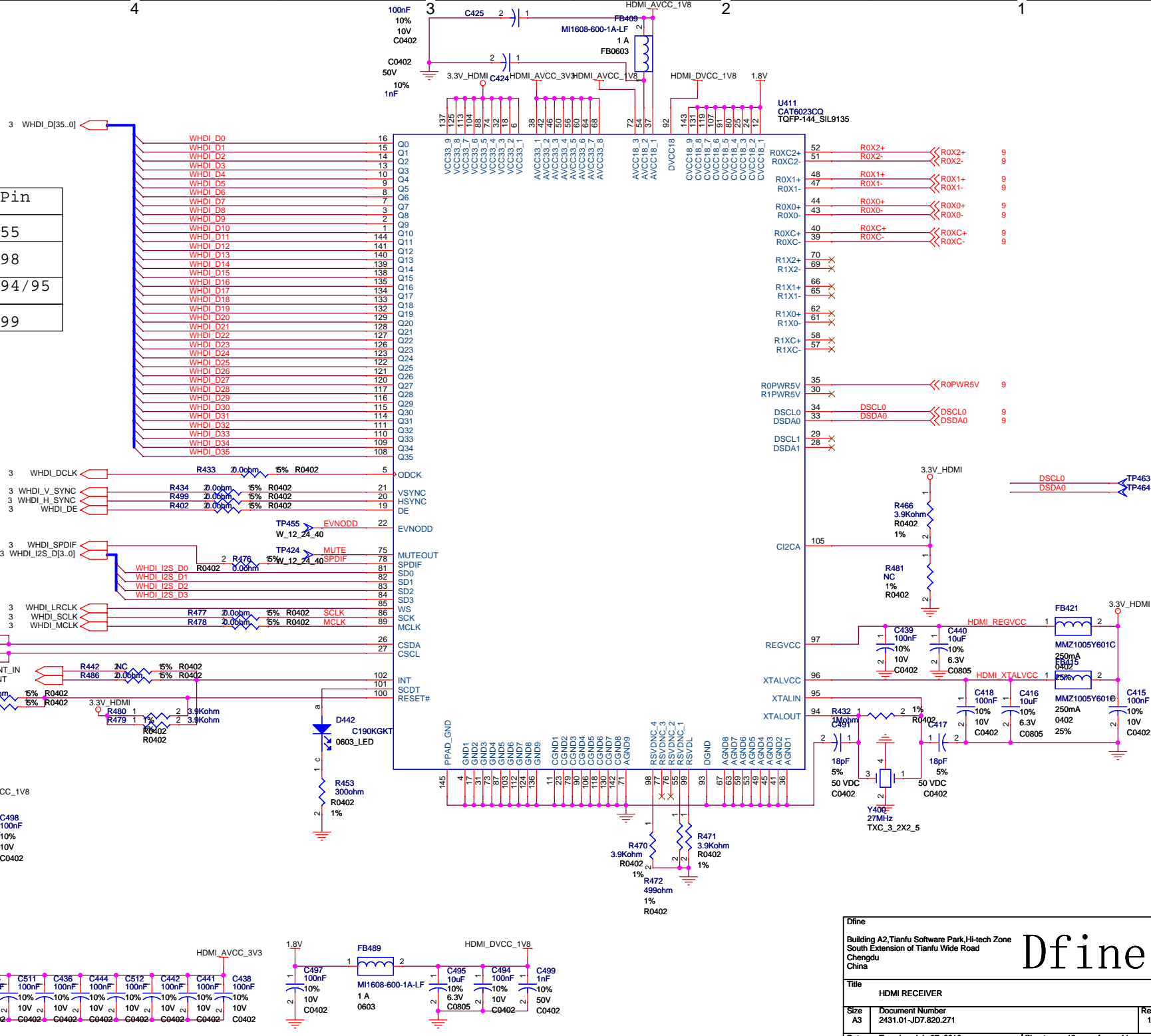

Dfine

Building A2, Tianfu Software Park, Hi-tech Zone
South Extension of Tianfu Wide Road
Chengdu
China

Title		HDMI RECEIVER	
Size	A3	Document Number	2431.01-JD7.820.271
Date:	Tuesday, July 27, 2010	Sheet	10 of 11
Rev	1.0		

I2C / SPI SELECTION

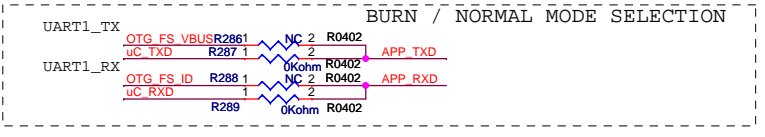
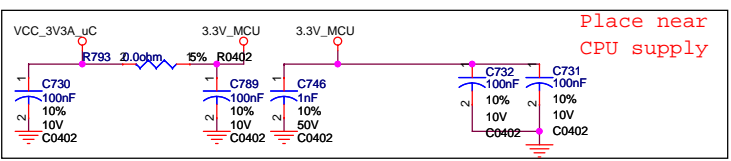
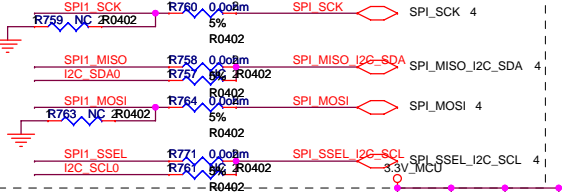

USB interface

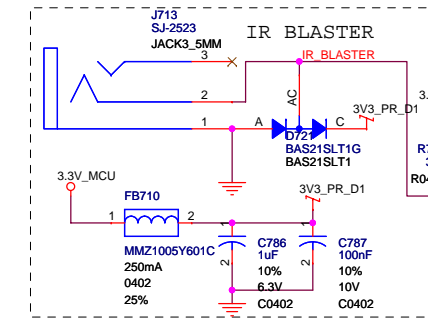
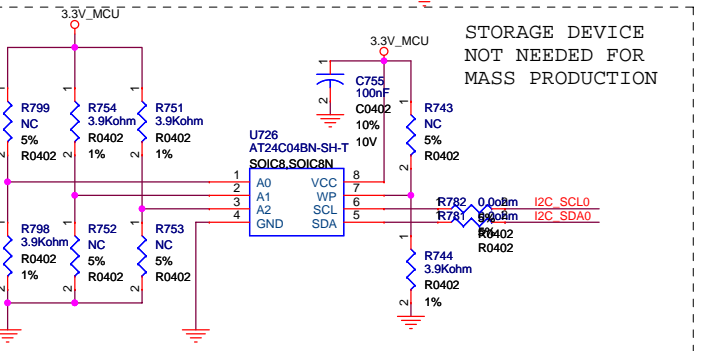
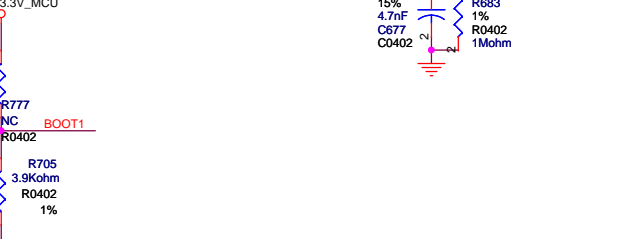
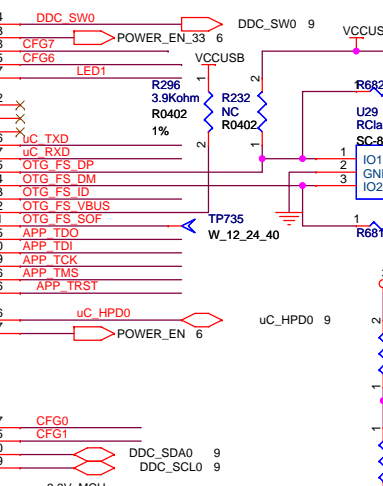
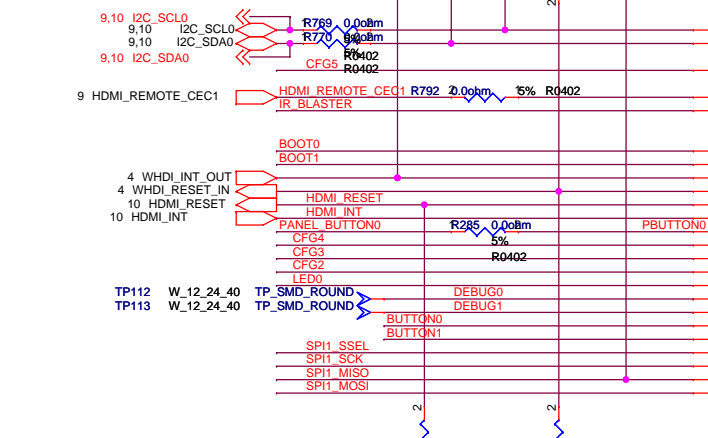
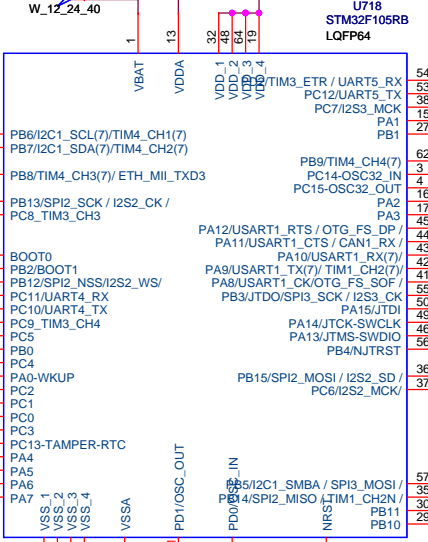
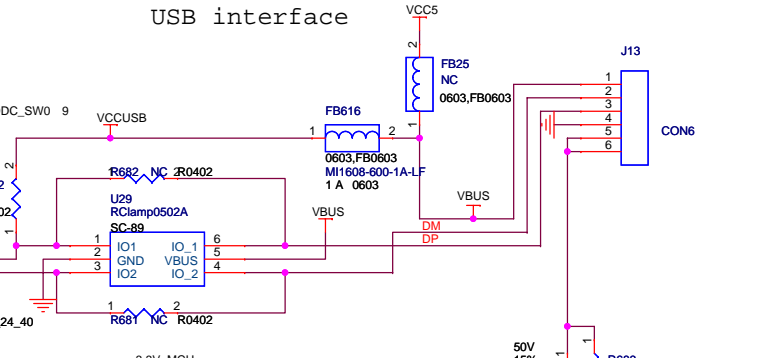

ICT TEST POINT

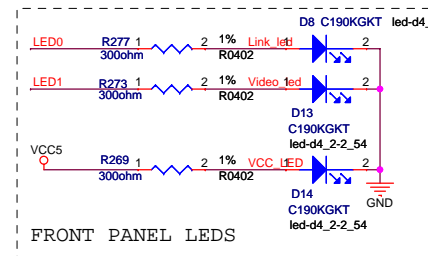
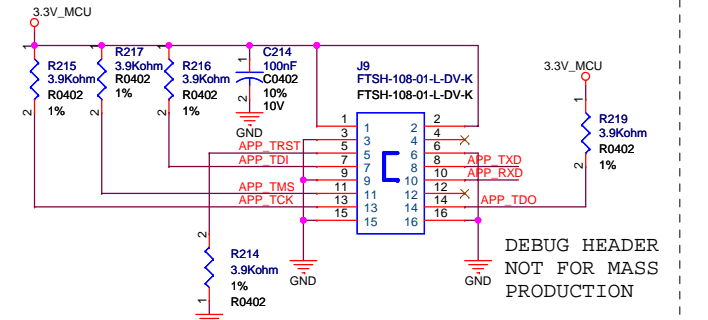
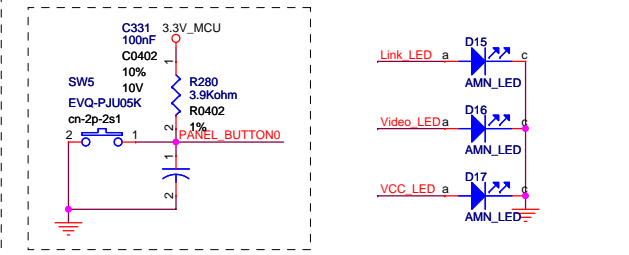
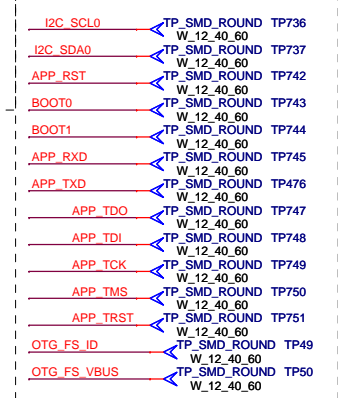

Dfine
 Building A2, Tianfu Software Park, Hi-tech Zone
 South Extension of Tianfu Wide Road
 Chengdu
 China

Title: uC

Size: A3 | Document Number: 2431.01-JD7.820.271 | Rev: 1.0

Date: Wednesday, July 28, 2010 | Sheet: 11 of 11