

User manual

DA14580 Antenna module for QFN48 package

UM-B-036

Abstract

*This document describes the Bluetooth® Smart antenna module, based on the DA14580 SoC.
Target hardware: da14580_rd_module_qfn48_vD, board number: 078-28-D.*

 DA14580 Antenna module for QFN48 package

Contents

Contents	2
Figures	4
Tables	4
1 Terms and definitions	6
2 References	6
3 Introduction	7
4 System overview	7
4.1 Features	7
4.2 Electrical characteristics	7
4.3 General description.....	8
4.4 Bluetooth Smart SoC.....	8
4.5 Schematic diagram.....	9
4.6 Module pinout	10
4.7 Module GPIOs	11
4.7.1 Reset.....	11
4.8 Power management.....	12
4.8.1 DC/DC converter in boost configuration	13
4.9 Crystals.....	13
4.10 OTP programming.....	14
4.11 Debugging/testing ports	14
4.12 RF section.....	14
4.12.1 Antenna	14
4.12.1.1 Radiation diagrams	16
4.12.1.2 Radiation pattern measurements.....	17
4.13 Tuning the 16 MHz crystal	18
4.14 Software.....	18
4.15 Test platform.....	18

 DA14580 Antenna module for QFN48 package

4.16	PCBA.....	19
5	Measurements	22
5.1	Receiver sensitivity (conducted).....	22
5.1.1	Test description	22
5.1.2	Test setup	22
5.1.3	Test results	22
5.2	Transmitter output power (conducted).....	24
5.2.1	Test description	24
5.2.2	Test setup	24
5.2.3	Test results	24
5.3	Current consumption.....	24
5.3.1	Test setup	24
5.3.2	Test results	25
6	FCC/IC Certification and CE marking	27
6.1	Standards and conformity assessment.....	27
6.2	FCC requirements regarding the end product and end user.....	28
6.2.1	End product marking	28
6.2.2	End product literature	28
6.3	Industry Canada requirements regarding the end product and end user.....	29
6.3.1	End product marking	29
6.3.2	End product literature	29
6.4	1999/5/EC Directive.....	29
6.4.1	RoHS compliance	32
7	Revision history	33

DA14580 Antenna module for QFN48 package

Figures

Figure 1: Antenna module block diagram	8
Figure 2: Schematic diagram of the DA14580 QFN48 antenna module	9
Figure 3: Module pin locations.....	10
Figure 4: Power management, DC/DC converter in buck configuration.....	12
Figure 5: Current consumption during an Advertising frame	12
Figure 6: DA14580 DC/DC converter circuit.....	13
Figure 7: RF section: PCB layout (left) and schematic (right)	14
Figure 8: Antenna geometry	15
Figure 9: Matching network: R5 (5.1 nH) and R6 (3.9 nH)	15
Figure 10: Antenna VSWR measurements	16
Figure 11: Far field antenna directivity @ 2.44 GHz	16
Figure 12: Radiation diagram for the module placed vertically on the long edge.....	17
Figure 13: Radiation diagram for the module placed horizontally	17
Figure 14: Interposer (078-46-A) for the QFN48 antenna module	18
Figure 15: Top view (left) and bottom view (right) of PCBA	19
Figure 16: Schematic of the DA14580 QFN48 antenna module	20
Figure 17: Test setup for the conducted RF measurements.....	22
Figure 18: Conducted output power per channel.....	24
Figure 19: Supply current during an Advertising frame	25
Figure 20: Supply current during periodic transmissions every 700 ms	25
Figure 21: Supply current during Extended Sleep mode.....	26

Tables

Table 1: QFN48 antenna module characteristics	7
Table 2: Module pin assignment (top view).....	10

DA14580 Antenna module for QFN48 package

Table 3: GPIO pins: available functions	11
Table 4: DA14580 DC/DC converter configurations.....	13
Table 5: Crystal characteristics.....	14
Table 6: QFN48 antenna module debug ports.....	14
Table 7: Far field antenna parameters @ 2.44 GHz.....	16
Table 8: PCB fabrication parameters.....	19
Table 9: Bill of Materials.....	21
Table 10: Conducted receiver sensitivity	23
Table 11: Peak current during Advertising mode.....	25
Table 12: Average current in Extended Sleep mode.....	26

DA14580 Antenna module for QFN48 package

1 Terms and definitions

BLE	Bluetooth Low Energy (now: Bluetooth Smart)
BOM	Bill Of Materials
DUT	Device Under Test
ERP	Effective Radiated Power
GPIO	General Purpose Input/Output
PCBA	Printed Circuit Board Assembled
PCB	Printed Circuit Board
RF	Radio Frequency
Rx	Receive
SoC	System on Chip
Tx	Transmit
VSWR	Voltage Standing Wave Ratio

2 References

1. [DA14580 Low Power Bluetooth Smart SoC, Datasheet, Dialog Semiconductor](#)
2. [AN-B-020: End product testing and programming guidelines, Application note, Dialog Semiconductor](#)

DA14580 Antenna module for QFN48 package

3 Introduction

The DA14580 QFN48 antenna module is based on the Dialog Semiconductor DA14580 Bluetooth[®] Smart SoC. It is a stand-alone system consisting of the DA14580 SoC in a QFN48 package, 16 MHz and 32 kHz crystals, a DC/DC converter and a printed antenna. The module was successfully tested for FCC/IC certification and CE marking. This document presents the module system, its technical specifications, physical dimensions and test results.

4 System overview

4.1 Features

- Highly integrated Dialog Semiconductor DA14580 *Bluetooth[®] Smart SoC*
- Module can be used stand-alone or as a data pump in a system with an external processor
- Antenna module in buck configuration certified according to FCC/IC and CE marking
- Module meets all Bluetooth Smart requirements
- No external crystal or additional passive components required for module operation
- Access to processor via JTAG, SPI, UART or I²C
- 32 GPIOs available on module at a 1.27 mm pitch, suitable for keyboard designs
- Operating voltage: 2.4 V to 3.6 V, suitable for operation from a single cell coin battery
- On-board printed inverted F-type antenna
- Up to 0 dBm RF transmitted power
- Receiver sensitivity: better than -92 dBm
- Supply current:
 - Transmit/Receive mode: typ. 5 mA peak current @ 3.0 V
 - Sleep mode: typ. 2 μ A average current
- 17.89 mm x 25.4 mm, 38 pins, two layer PCBA

4.2 Electrical characteristics

Table 1: QFN48 antenna module characteristics`

Parameter	Description	Conditions	Min	Typ	Max	Unit
V _{BAT}	battery supply voltage		2.4	3.0	3.3	V
f _{OPER}	operating frequency		2400		2483.5	MHz
P _O	output power	conducted; V _{BAT} = 3 V, T _A = 25 °C		0		dBm
P _{SENS}	sensitivity level	V _{BAT} = 3 V, T _A = 25 °C		-92		dBm
I _{BAT_TX}	battery supply current	transmit mode; peak value; V _{BAT} = 3 V, T _A = 25 °C		5		mA
I _{BAT_SLP}	battery supply current	sleep mode; average value; V _{BAT} = 3 V, T _A = 25 °C		2		μ A

DA14580 Antenna module for QFN48 package

4.3 General description

The DA14580 QFN48 antenna module consists of the DA14580 Bluetooth Smart SoC, RF section, GPIOs, crystals, power management, debugging/testing and OTP programming. Only one external power supply is required for operating the module.

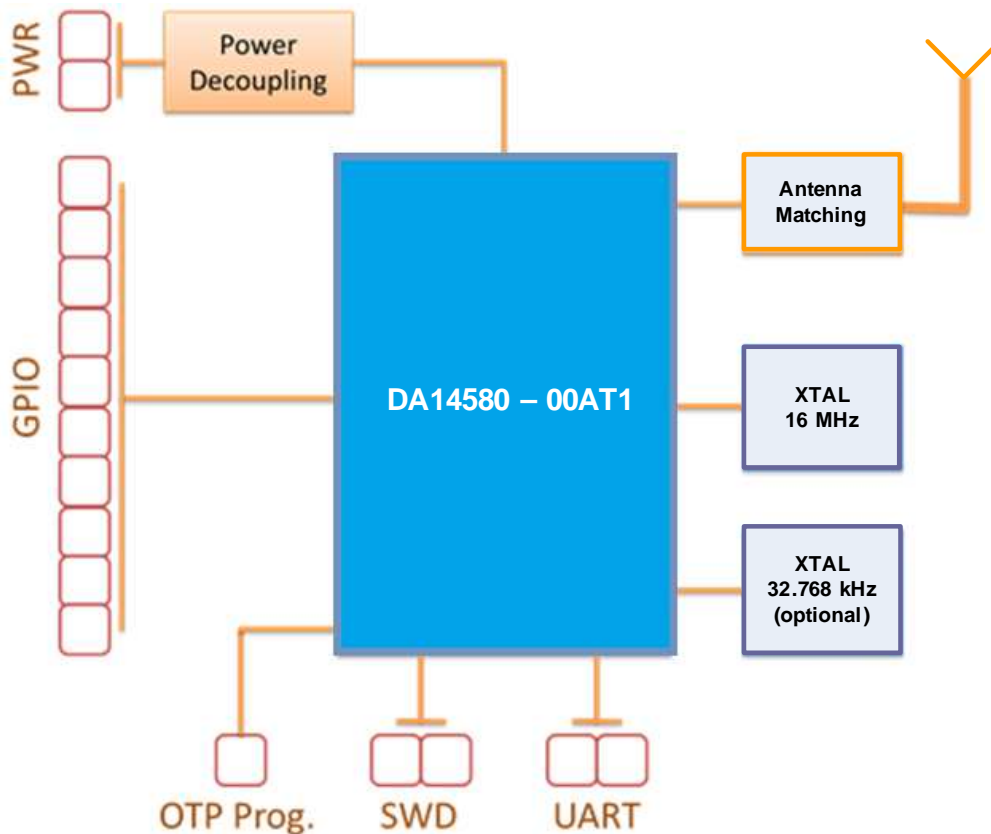

Figure 1: Antenna module block diagram

4.4 Bluetooth Smart SoC

The DA14580 integrated circuit has a fully integrated radio transceiver and baseband processor for *Bluetooth® Smart*. It can be used as an application processor as well as a data pump in systems with an external processor.

The DA14580 contains an embedded One-Time-Programmable (OTP) memory for storing Bluetooth profiles as well as custom application code. The qualified Bluetooth Smart protocol stack which is stored in a dedicated ROM, and the customer application software which is stored in system RAM, both run on the embedded ARM® Cortex®-M0 processor. Low leakage Retention RAM is used to store sensitive data and connection information while in Deep Sleep mode.

The radio transceiver implements the RF part of the Bluetooth Smart protocol. Together with the Bluetooth 4.0 PHY layer, it provides a 93 dB RF link budget for reliable wireless communication. All RF blocks are supplied by on-chip low drop out regulators (LDOs). The RF port is single ended 50 Ω, so no external balun is required.

The DA14580 has dedicated hardware for the Link Layer implementation of Bluetooth Smart and interface controllers for enhanced connectivity capabilities.

The DA14580 is equipped with a DC/DC converter that can be configured either for buck or boost mode operation. On this module both configurations are available. The default configuration is a buck mode DC/DC converter. Also, the FCC/ETSI certification is valid only for the buck configuration.

DA14580 Antenna module for QFN48 package

4.5 Schematic diagram

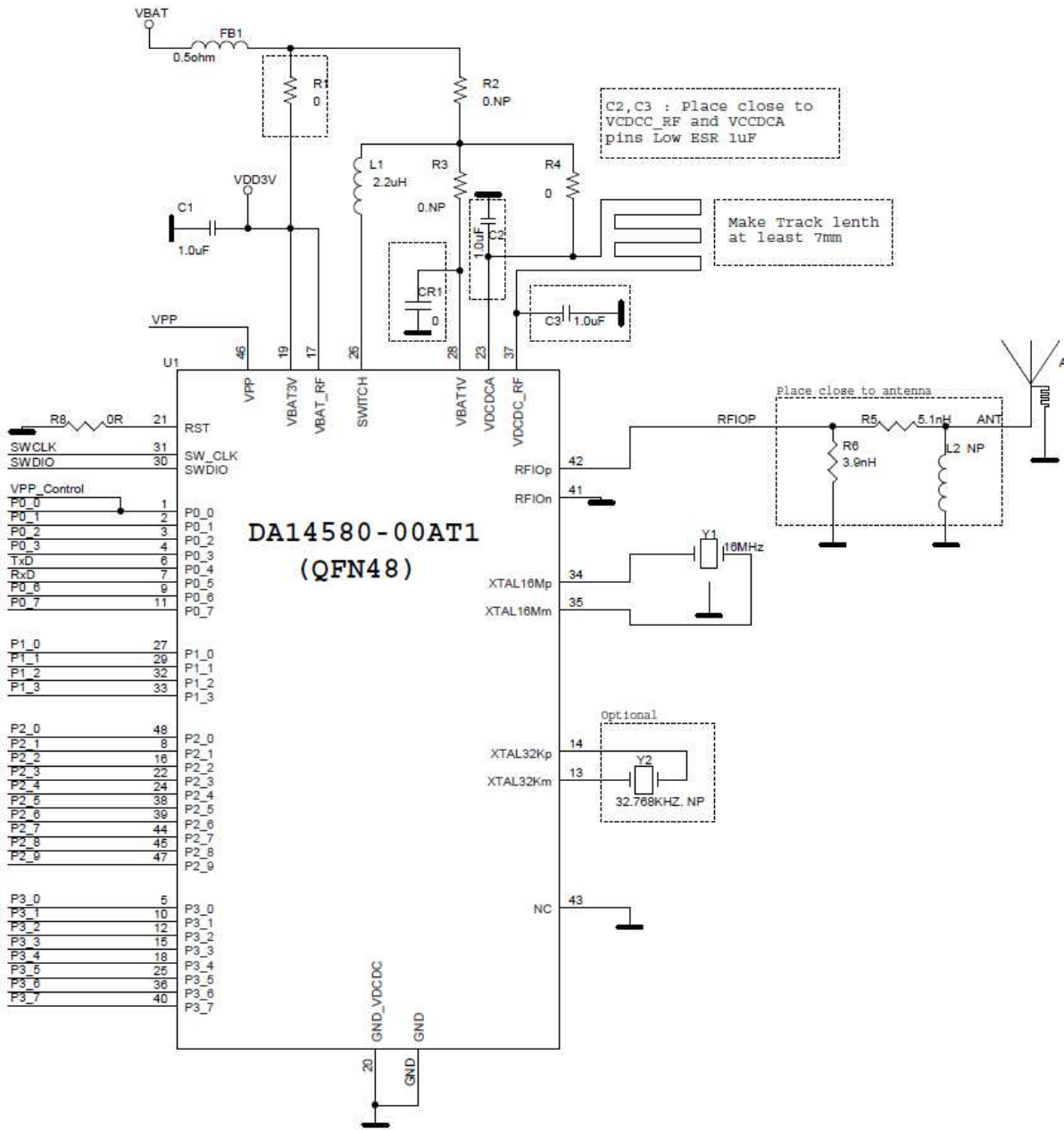

Figure 2: Schematic diagram of the DA14580 QFN48 antenna module

DA14580 Antenna module for QFN48 package

4.6 Module pinout

All available pins of the DA14580 SoC are routed out to the pins of the QFN48 antenna module. Module pin numbers and names are given in Figure 3 and Table 2. The module pins use the corresponding names of the DA14580 QFN48 integrated circuit.

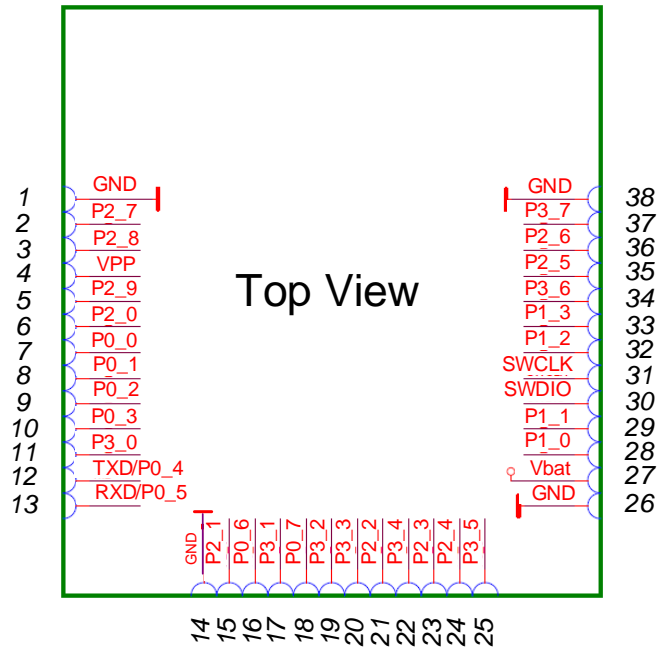

Figure 3: Module pin locations

Table 2: Module pin assignment (top view)

Pin no.	Pin name (PCB left side)	Pin no.	Pin name (PCB bottom side)	Pin no.	Pin name (PCB right side)
1	GND	14	GND	26	GND
2	P2_7	15	P2_1	27	VBAT
3	P2_8	16	P0_6	28	P1_0
4	VPP	17	P3_1	29	P1_1
5	P2_9	18	P0_7	30	SWDIO
6	P2_0	19	P3_2	31	SW_CLK
7	P0_0	20	P3_3	32	P1_2
8	P0_1	21	P2_2	33	P1_3
9	P0_2	22	P3_4	34	P3_6
10	P0_3	23	P2_3	35	P2_5
11	P3_0	24	P2_4	36	P2_6
12	P0_4 (TxD)	25	P3_5	37	P3_7
13	P0_5 (RxD)			38	GND

DA14580 Antenna module for QFN48 package

4.7 Module GPIOs

The QFN48 antenna module provides 32 general purpose input/output pins (including JTAG signals). The interfaces are multiplexed with the GPIOs and can be enabled by appropriate programming. The available GPIO functions are presented in [Table 3](#).

The following digital interfaces are available externally to the module:

- Two UARTs with hardware flow control up to 1 MBd
- SPI interface
- I²C bus at 100 kHz, 400 kHz
- 3-axis capable quadrature decoder

In addition, a 4-channel 10-bit ADC is also available externally to the module.

Table 3: GPIO pins: available functions

Interface	Description	Pins	Comments
UART1 (UTX, URX)	Bootable UART	P00, P01	57.6 kBd on booting
		P02, P03	115.2 kBd on booting
		P04, P05	57.6 kBd on booting. This combination is selected for the UART on this module.
		P06, P07	9.6 kBd on booting
UART1 (RTS, CTS)	Bootable UART	P02, P03	
		P06, P07	
UART1 or UART2	UART debug port	Any port and any pin combination	
SPI	Bootable SPI	P00, P03, P05, P06	Up to 8 MHz.
	Non-bootable SPI	Any port and any pin combination	
I2C	Bootable I ² C	P00, P01	100 kHz on booting for all combinations
		P02, P03	
		P04, P05	
	Non-bootable I ² C	Any port, any pin	
ADC		P00, P01, P02, P03	The voltage on these pins must be lower than V _{BAT} .
Test points	Frequency calibration	P05	16 MHz oscillator output. Can be used for clock calibration.
Interrupts		Any port and any pin combination	
Keypad		Any port , any pin	column or row

4.7.1 Reset

The reset signal of the DA14580 (pin RST) is active high. On the QFN48 antenna module the RST pin of the DA14580 is connected to GND via a resistor R8 (0 Ω). Consequently, the only way to perform a hardware reset of the DA14580 on the antenna module is by switching off the power.

DA14580 Antenna module for QFN48 package

4.8 Power management

The QFN48 antenna module is supplied by a single power supply via pin 27 (VBAT). The supply voltage of the module follows the specification of the DA14580 IC in buck configuration. The supply voltage ranges from 2.4 V to 3.6 V.

Embedded in the DA14580, the DC/DC converter and LDOs produce all voltages required for the system operation. The DC/DC converter is supplied from V_{BAT} through a bead (FB1) and produces 1.4 V that feeds the internal LDOs. The LDOs supply the digital, analog and RF sections of the chip with 1.2 V. Finally, the I/O ring is supplied from V_{BAT} .

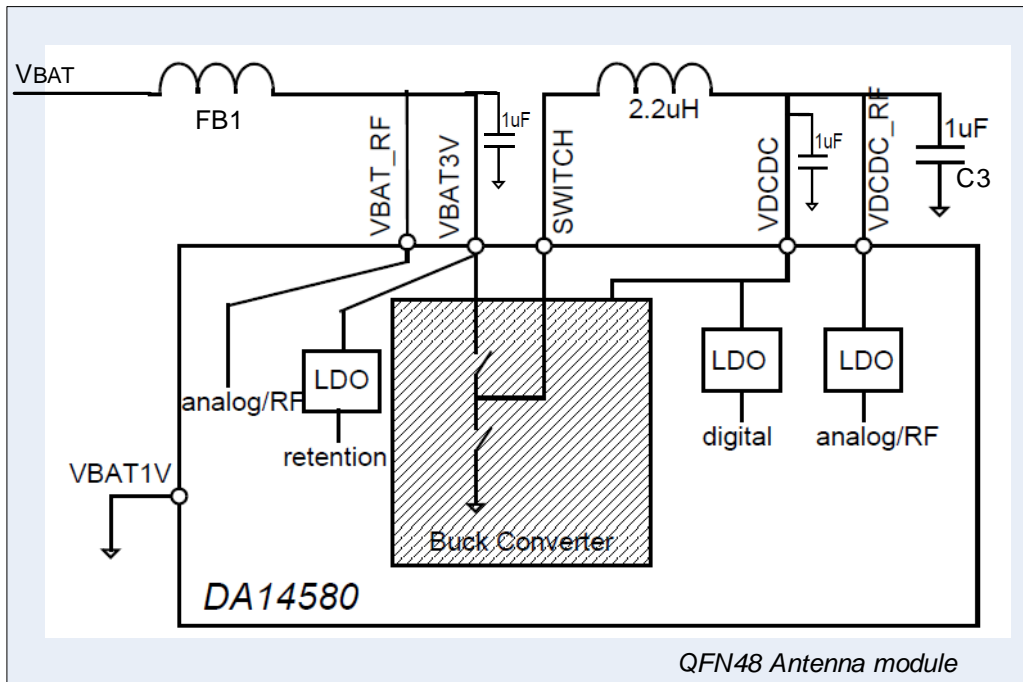

Figure 4: Power management, DC/DC converter in buck configuration

The overall current consumption of the QFN48 antenna module in transmit mode is in the range of 5 mA, whereas in sleep mode the consumption is in the range of 2 μ A. See [Figure 5](#).

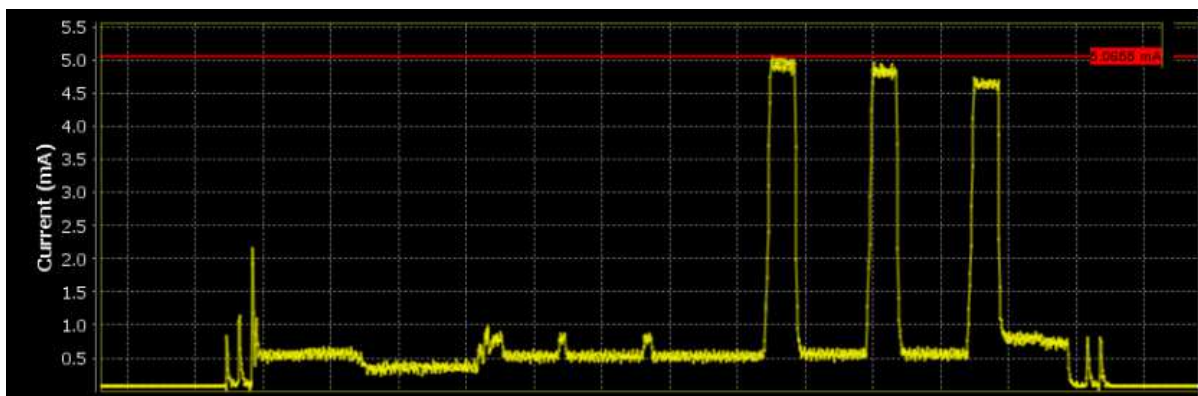

Figure 5: Current consumption during an Advertising frame

DA14580 Antenna module for QFN48 package

4.8.1 DC/DC converter in boost configuration

Supplying the QFN48 antenna module at a lower voltage (down to 0.9 V) is feasible, but modification of the module’s components is needed. Please note that this configuration has not been used in the tests for the FCC/ETSI certification.

Table 4: DA14580 DC/DC converter configurations

Buck configuration (default)	
Supply voltage	2.4 V to 3.6 V
Populated components	R1 = 0 Ω, R4 = 0 Ω, CR1 = 0 Ω
Not populated components	R2, R3
FCC/CE certification	Yes
Boost configuration	
Supply voltage	0.9 V to 2.0 V (single cell alkaline battery)
Populated components	R2 = 0 Ω, R3 = 0 Ω, CR1 = 1 μF
Not populated components	R1, R4
FCC/CE certification	No

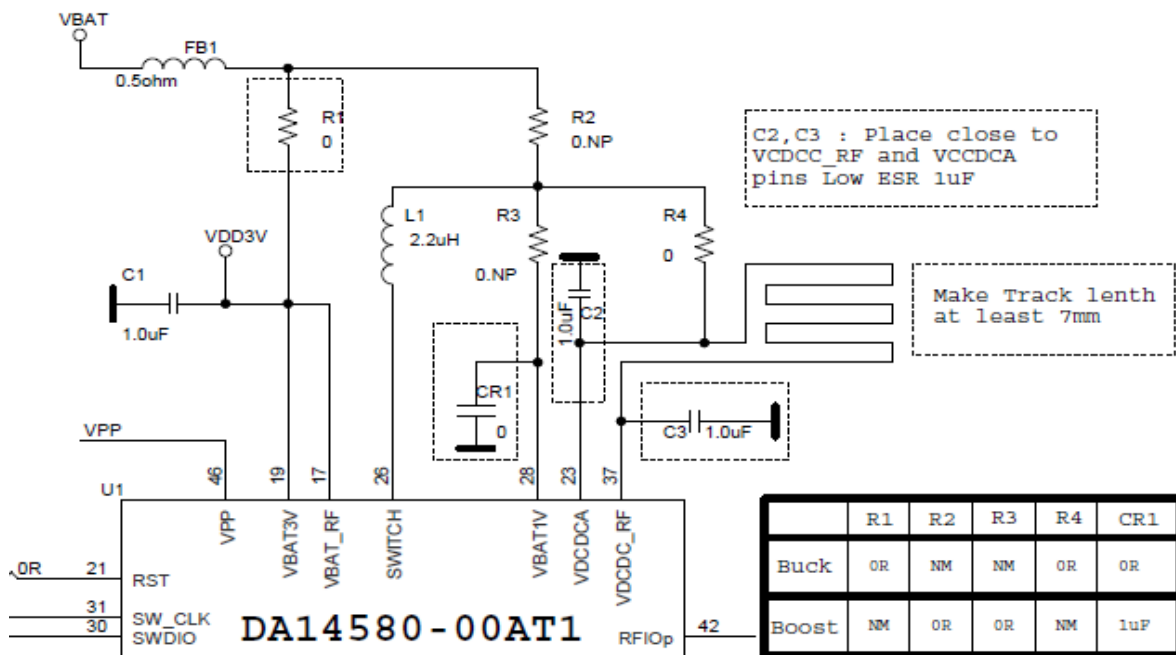

Figure 6: DA14580 DC/DC converter circuit

4.9 Crystals

The frequency tolerance specification for BLE is ±50 ppm. To compensate for ageing and offset effects, the external crystal of 16 MHz must have an accuracy of ±20 ppm or better. On the QFN48 antenna module the 16 MHz crystal (Y1) has a fundamental frequency of 16 MHz ±10 ppm and a load capacitance of 10 pF. The crystal is located on the module itself. The crystal oscillator frequency can be tuned using a programmable capacitance bank that is embedded in the DA14580.

For sleep mode the on-chip RCX oscillator is used (typ. 10 kHz). In addition, a 32.768 kHz crystal (Y2) with a tolerance of ±50 ppm can be mounted on the module.

DA14580 Antenna module for QFN48 package

Table 5: Crystal characteristics

Frequency	Accuracy	Load capacitance	Size	Placement
16 MHz	±10 ppm	10 pF	2.5 mm x 2.0 mm	Populated
32.768 kHz	±20 ppm	7 pF	3.2 mm x 1.5 mm	Optional

Note: When the DC/DC converter configuration is changed to boost mode, a 32.768 kHz crystal must be mounted. The on-chip RCX oscillator can only be used in buck mode.

4.10 OTP programming

For programming the OTP memory of the DA14580, a DC voltage of 6.7 V (typ.) must be applied to pin 4 (VPP).

4.11 Debugging/testing ports

Two ports are available for testing/debugging or software development: JTAG and UART: The pin assignments of these ports are given in [Table 6](#).

Table 6: QFN48 antenna module debug ports

Function	QFN48 antenna module		DA14580	
	Pin name	Pin no.	Pin name	Pin no.
UART transmit (UTX)	TxD	13	P0_5	7
UART receive (URX)	RxD	12	P0_4	6
JTAG data	SWDIO	30	SWDIO	30
JTAG clock	SWCLK	31	SWCLK	31

4.12 RF section

The DA14580 has a single pin RF input/output port. The RF section of the QFN48 antenna module consists of a printed antenna and the matching network of R5, R6 and L2. L2 is not populated. See [Figure 7](#).

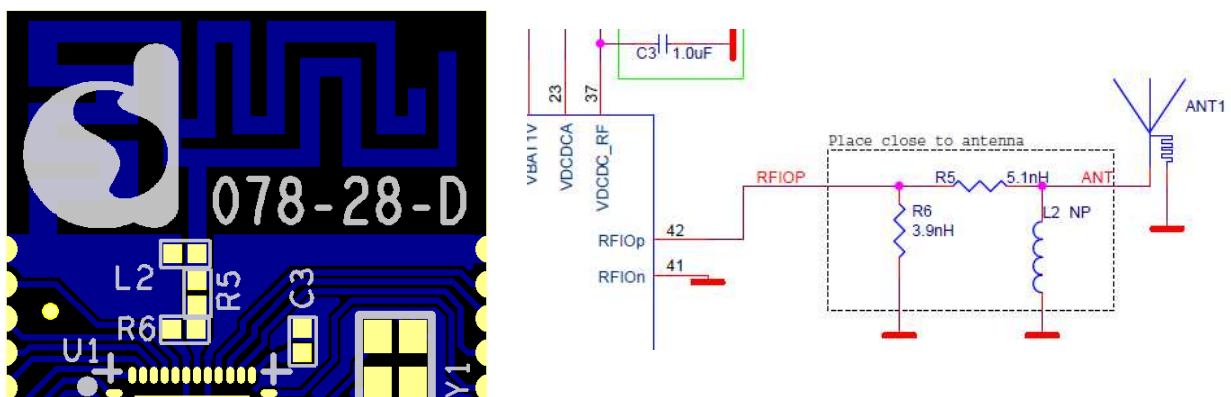

Figure 7: RF section: PCB layout (left) and schematic (right)

4.12.1 Antenna

A broadband variant of a printed F-antenna is used. A matching network is required for achieving the maximum power transfer possible. The matching network consists of two inductances: R5 (series coil: 5.1 nH, 0402, LQP series) and R6 (shunt coil: 3.9 nH, 0402, LQP series).

DA14580 Antenna module for QFN48 package

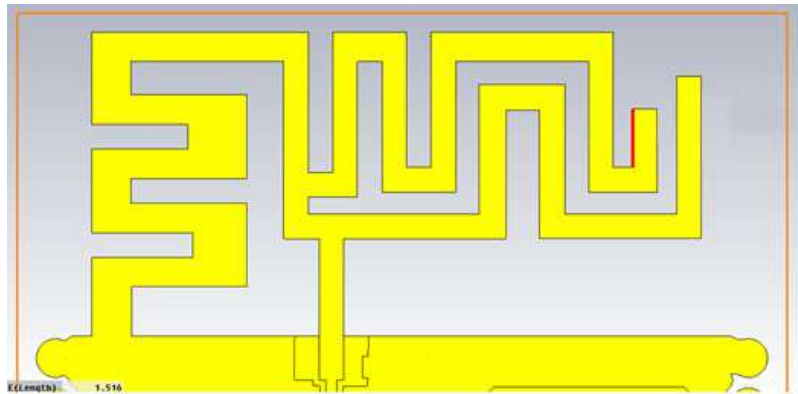

Figure 8: Antenna geometry

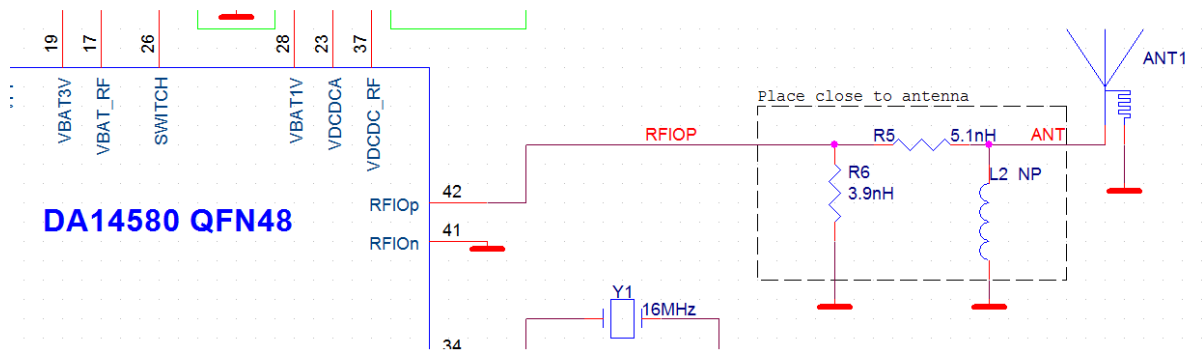
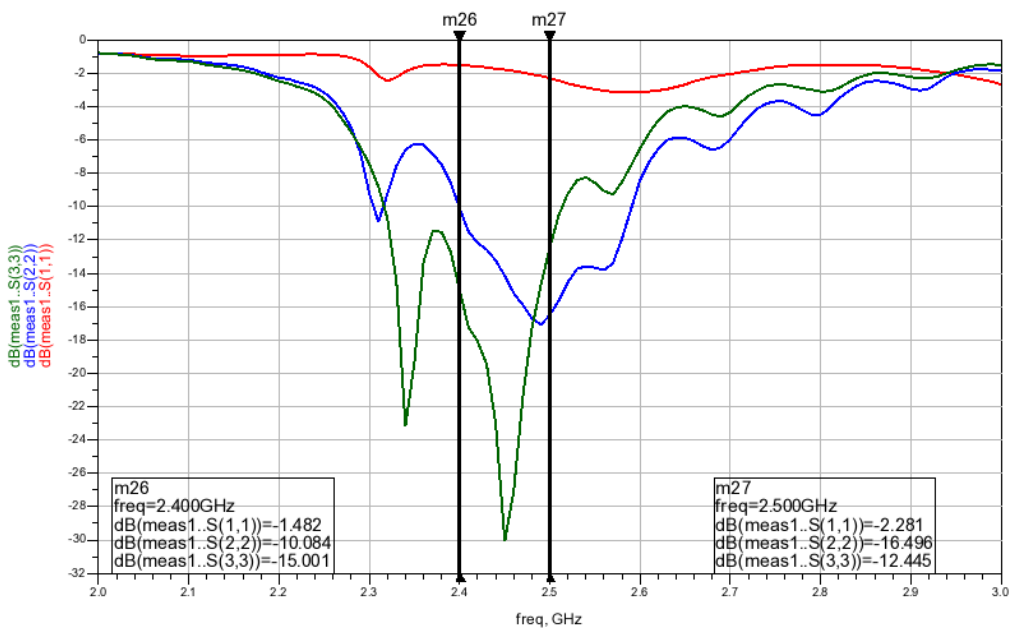

Figure 9: Matching network: R5 (5.1 nH) and R6 (3.9 nH)



Red: no matching
 Blue: R5 = 4.7 nH, R6 = 3.9 nH
 Green: R5 = 5.1 nH, R6 = 3.9 nH

DA14580 Antenna module for QFN48 package

Figure 10: Antenna VSWR measurements

4.12.1.1 Radiation diagrams

Gain calculations were performed. The maximum gain was measured at 2.225 dBi. See Table 7.

Table 7: Far field antenna parameters @ 2.44 GHz

Parameter	Value
Frequency	2.44 GHz
Radiation efficiency	-1.882 dB
Total efficiency	-6.662 dB
Directivity	2.225 dBi

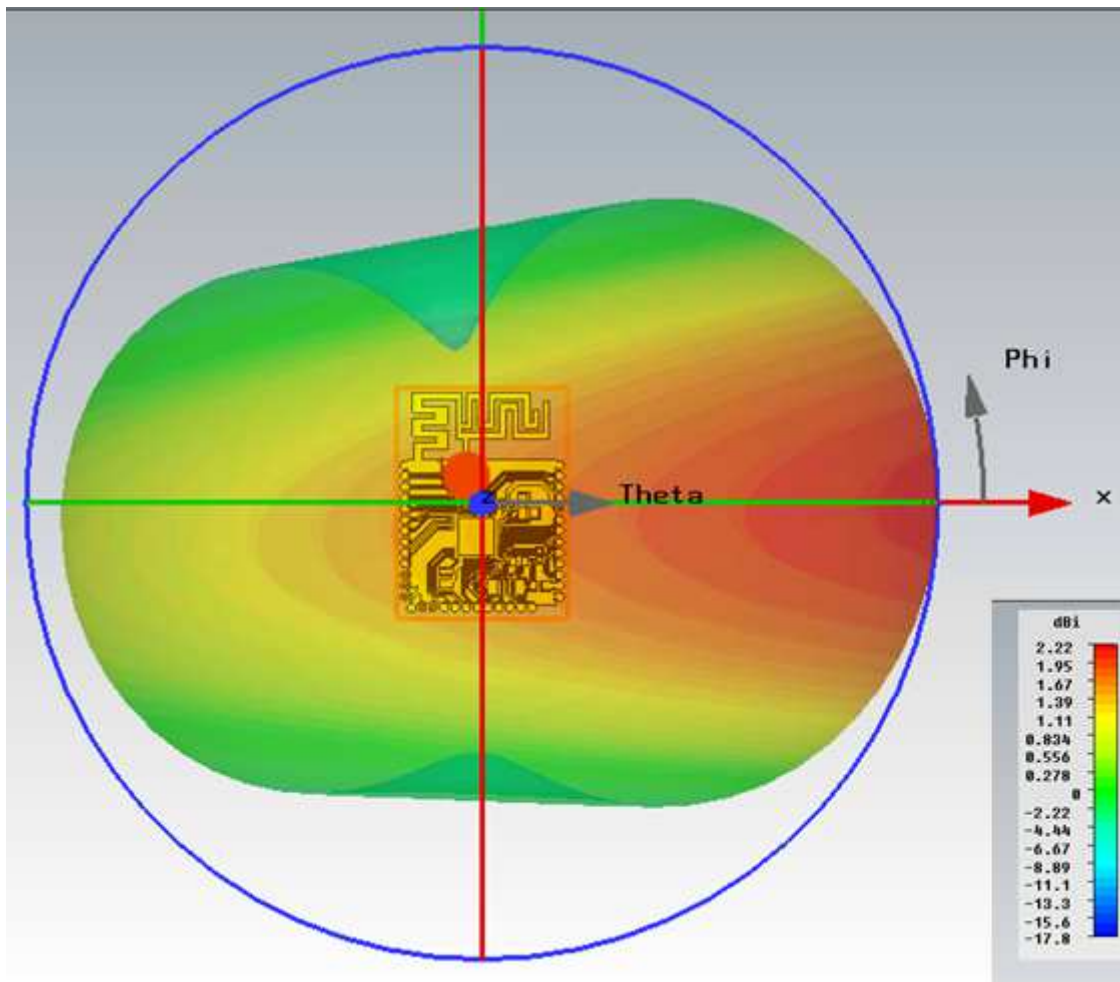

Figure 11: Far field antenna directivity @ 2.44 GHz

DA14580 Antenna module for QFN48 package

4.12.1.2 Radiation pattern measurements

Measurements of the radiation pattern in an anechoic chamber for vertical and horizontal positions of the module are given in Figure 12 and Figure 13, respectively.

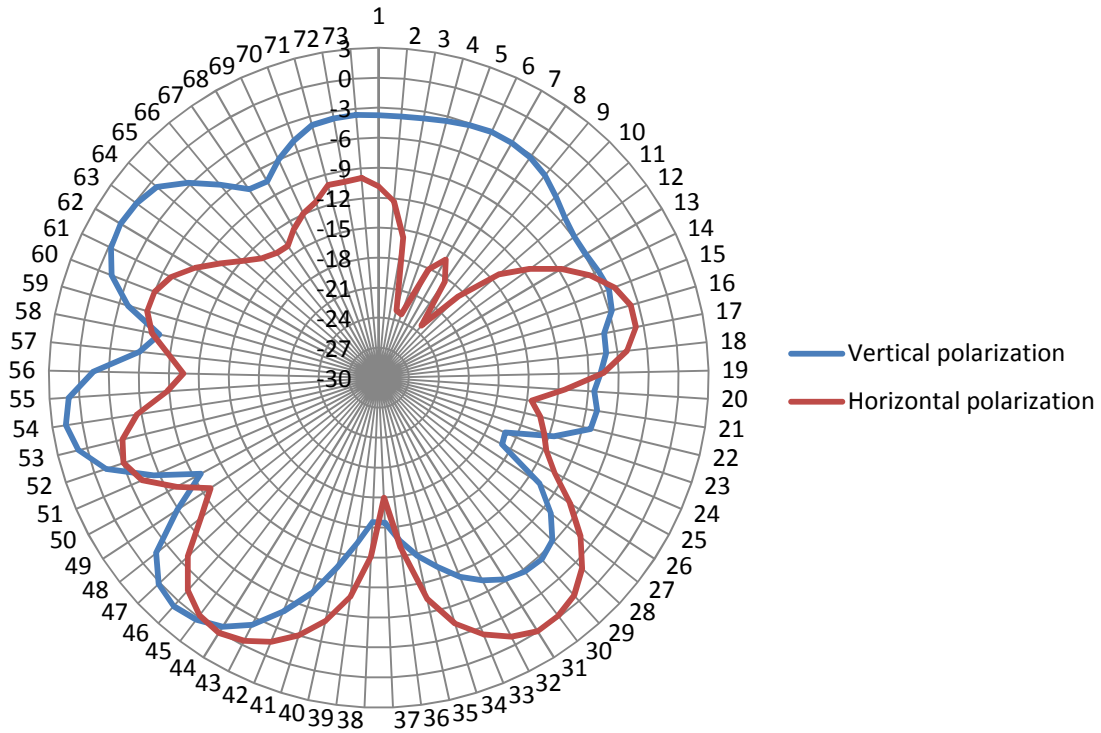

Figure 12: Radiation diagram for the module placed vertically on the long edge

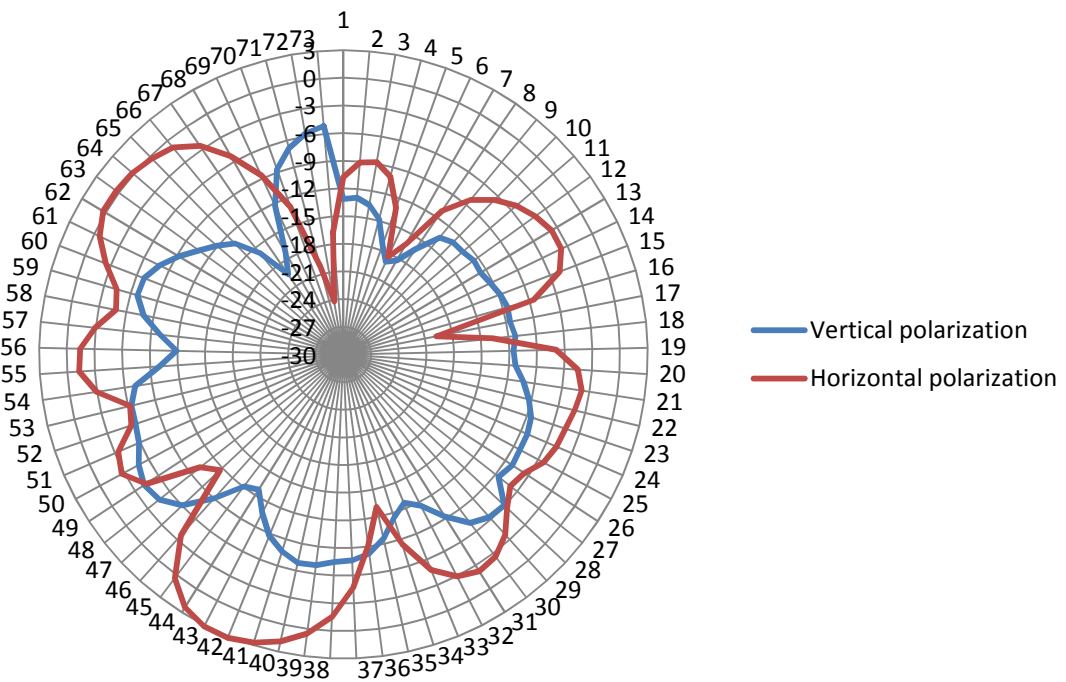

Figure 13: Radiation diagram for the module placed horizontally

DA14580 Antenna module for QFN48 package

4.13 Tuning the 16 MHz crystal

The accuracy of the 16 MHz crystal ($\pm 10\text{ppm}$) guarantees the ‘in spec’ operation of the QFN48 antenna module. However, further trimming of the 16 MHz crystal is possible using the procedure that is described in *AN-B-020 End product testing and programming guidelines*. See Ref.[2].

4.14 Software

The standard SDK release software, without modifications, can be used for testing or operating the QFN48 antenna module.

4.15 Test platform

An interposer (078-46-A) was built for hardware interfacing the Expert DK Motherboard (580-MB-vC2 / 078-10-C2) to the QFN48 antenna module. The interposer can be used as a stand-alone platform, as it has a debug port (J39). The debug port consist of JTAG, UART, VPP, VBAT and GND signals.

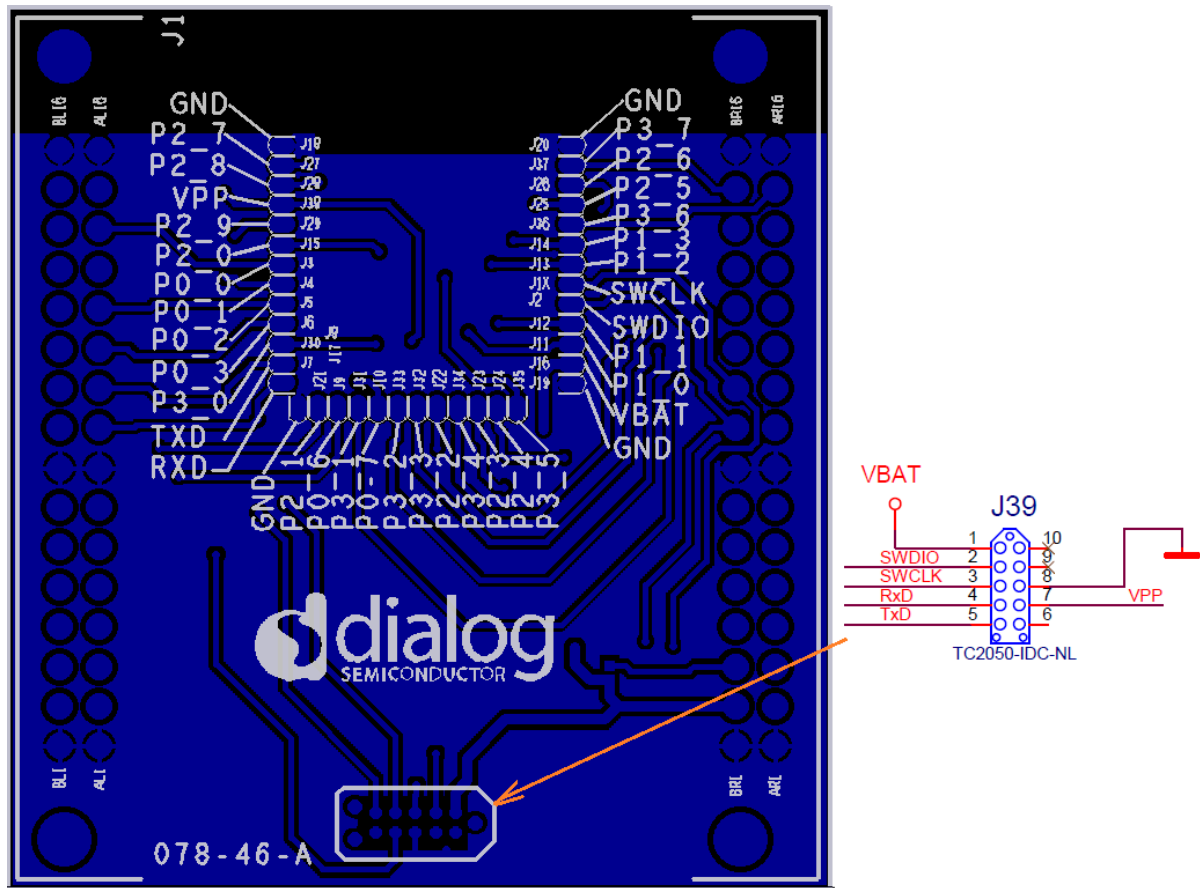

Figure 14: Interposer (078-46-A) for the QFN48 antenna module

DA14580 Antenna module for QFN48 package

4.16 PCBA

A two-layer FR4 PCB with 1 mm standard thickness is used. The PCB size is 25.4 mm x 17.9 mm. There are 38 connection pads which are made as castellation (1/2 open drill) with 1.27 mm pitch. The PCB layout is shown in [Figure 15](#) and the fabrication parameters are given in [Table 8](#).

The schematic diagram and BOM of the QFN48 antenna module are presented in [Figure 16](#) and [Table 9](#), respectively.

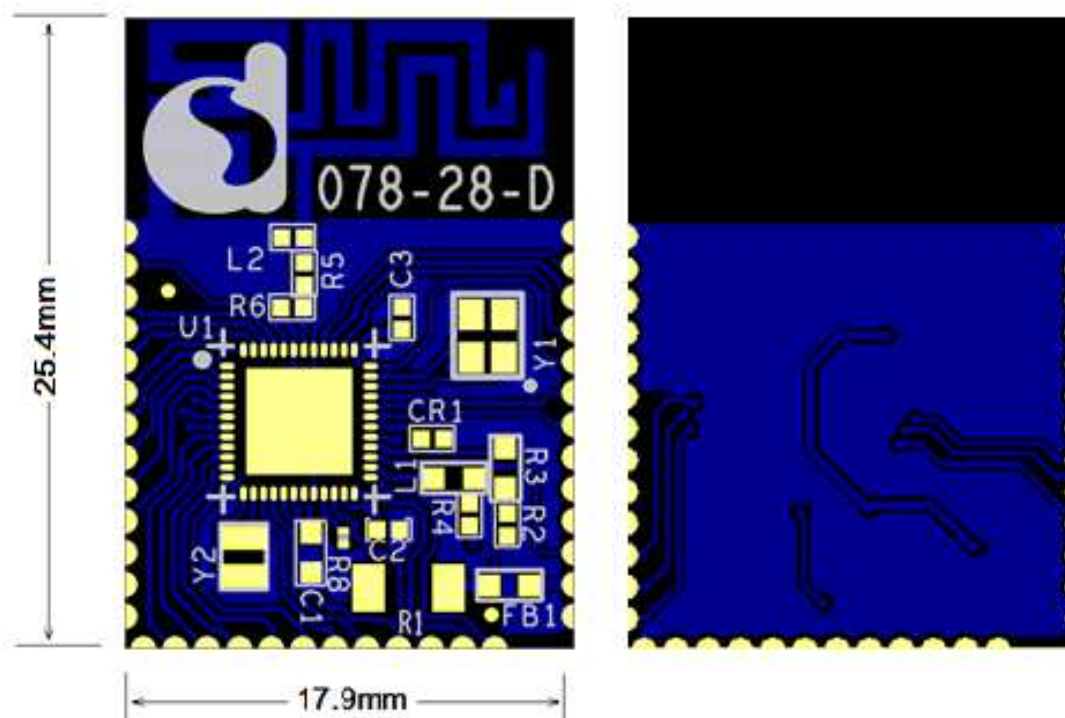

Figure 15: Top view (left) and bottom view (right) of PCBA

Table 8: PCB fabrication parameters

Number of layers	2
Core material	FR4 IMP – 1.0 mm
Top copper thickness	0.018 mm
Bottom copper thickness	0.018 mm
Outer layer track width	0.100 mm
Hole density	<1000 per dm ²
Outer layer isolation distance	0.125 mm
Hole diameter	0.45 mm
Outer layer annular ring	0.100 mm

DA14580 Antenna module for QFN48 package

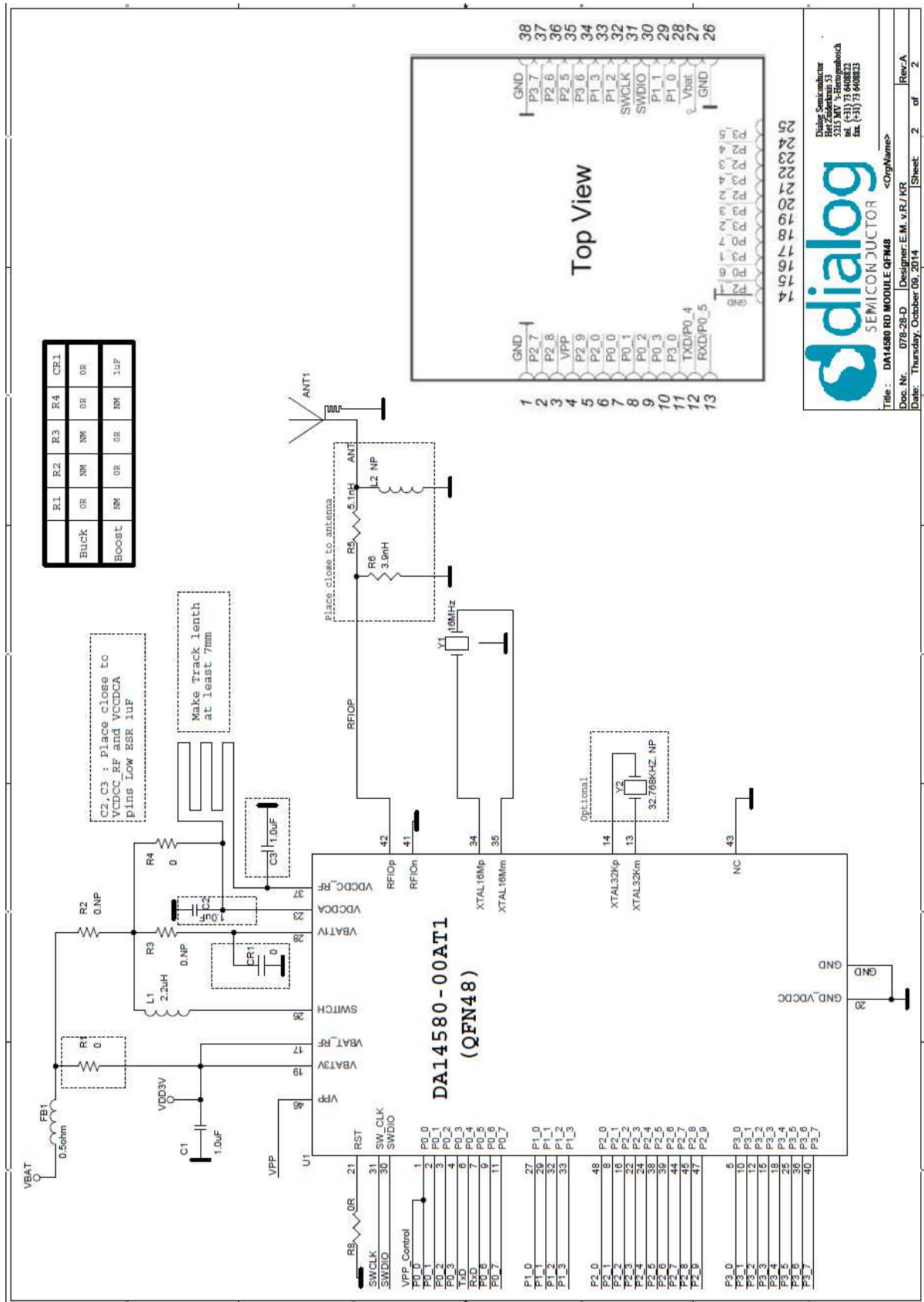

Figure 16: Schematic of the DA14580 QFN48 antenna module

DA14580 Antenna module for QFN48 package
Table 9: Bill of Materials

No	Qty	Description	Part Ref	Value	Part Number	Package	Manufacturer
1	1	CAP CERM 1.0uF 16V X7R 0603	C1	1.0 μ F	0603YC105K AT2A	0603	AVX Corporation
2	2	CAP MLCC, 0204, 1UF, 6.3V, 20%, X5R	C2 C3	1.0 μ F	GRM155R70 G105KA12D	0402	Murata Electronics
3	2	RES 0.0 OHM 1/16W 5% 0402 SMD	CR1 R4	0 Ω	CRCW04020 000Z0ED	0402	Vishay/Dale
4	1	FILTER CHI0.5ohm 0.4A 0603	FB1		BLM18AG102 SN1D	0603	Murata Electronics
5	1	INDUCTOR Power 2.2uH, 500mA, 400MHz	L1	2.2 μ H	BRL1608T 2R2M	0603	Taiyo Yuden
6	1	RESISTOR, THICK FILM, 0 OHM, 250mW, 5%	R1	0 Ω	RC1206JR- 070RL	1206	YAGEO
7	1	INDUCTOR RF, 0402, 5.1NH, \pm 0.3NH, 0.26ohm	R5	5.1 nH	L-07C5N1 SV6T	0402	JOHANSON TECHNOLOGY
8	1	RF INDUCTOR 0402 3.9NH, \pm 0.3NH 0.22ohm	R6	3.9 nH	L-07C3N9 SV6T	0402	Johanson Technology Inc
9	1	RESISTOR, 0201, 0R0	R8	0 Ω	CRCW02010 000Z0ED	0201	VISHAY DRALORIC
10	1	DA14580 Bluetooth Low Energy SOC – QFN48	U1		DA14580-00AT1	QFN48, 6x 6 x 0.9mm	DIALOG SEMI
11	1	CRYSTAL 16.000MHZ 10PF SMT	Y1	16 MHz	7M-16.000 MEEQ-T	xtal4p 25x20	TXC
Not Populated							
1	1	Inductor	L2	NM		0402	
2	1	Resistor	R3	0 Ω		0603	
3	1	crystal 32.768KHZ, \pm 20ppm, 7PF	Y2	32.768 kHz	ABS06-32.768KHz- 7-T	2x1.2mm	Abracon Corporation
4	1	Resistor	R2	0 Ω	CRCW0402 0000 Z0ED	0402	Vishay/Dale

DA14580 Antenna module for QFN48 package

5 Measurements

5.1 Receiver sensitivity (conducted)

5.1.1 Test description

In this test the conducted RF sensitivity of the QFN48 antenna module was measured.

5.1.2 Test setup

The supply voltage (3.0 V DC) was connected between the PCB pads 27 (VBAT) and 26 (GND). The R&S® CBT Bluetooth® Tester from Rohde & Schwarz was used. Component R5 was removed. The semi-rigid cable was soldered at this pad. See [Figure 17](#).

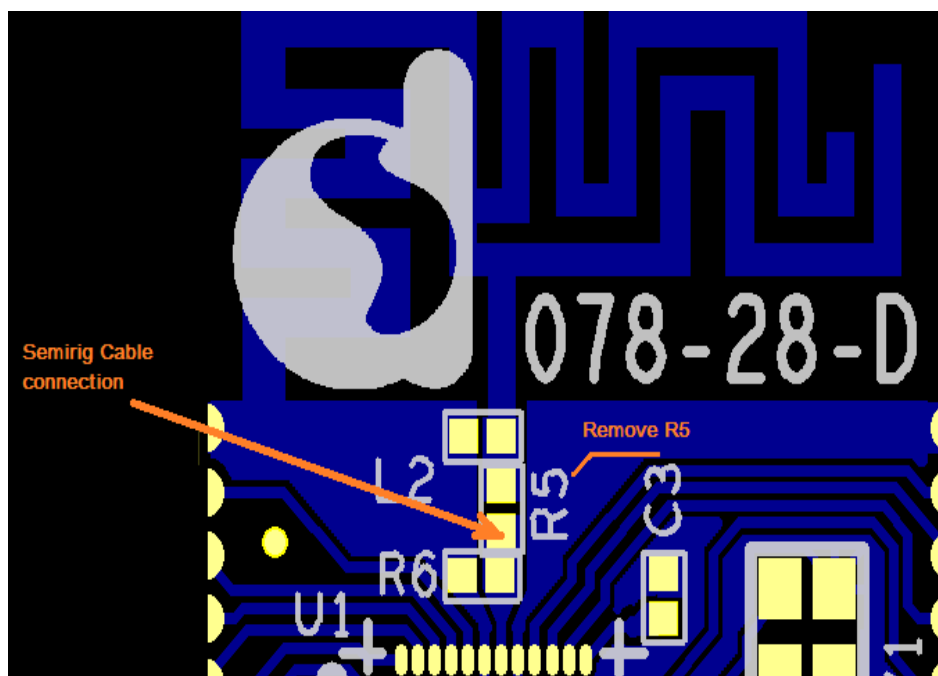

Figure 17: Test setup for the conducted RF measurements

5.1.3 Test results

The conducted RF sensitivity using a 'dirty' transmitter is better than -90 dBm for most channels. Lower sensitivity has been noticed on some channels. This is caused by harmonics of the 16 MHz oscillator. The results for one of the modules are shown [Table 10](#).

DA14580 Antenna module for QFN48 package

Table 10: Conducted receiver sensitivity

Bluetooth Low Energy PER Search

TX Start Level: -96.0 dBm, Packets: 1000, Payload: PRBS 9, Length: 37 Bytes, Dirty Transmitter: specification table

Channelscan: from Ch. 00 to Ch. 39, with detailed values

Test Name and Condition	Lower Limit	Upper Limit	Measured Value	P/F
RX Level @ Ch: 00, PER: 29.60%, Count: 08			-91.50 dBm	✓
RX Level @ Ch: 01, PER: 30.00%, Count: 17			-91.60 dBm	✓
RX Level @ Ch: 02, PER: 31.20%, Count: 10			-91.60 dBm	✓
RX Level @ Ch: 03, PER: 29.80%, Count: 15			-91.40 dBm	✓
RX Level @ Ch: 04, PER: 28.90%, Count: 14			-91.40 dBm	✓
RX Level @ Ch: 05, PER: 30.90%, Count: 12			-91.40 dBm	✓
RX Level @ Ch: 06, PER: 30.50%, Count: 05			-91.20 dBm	✓
RX Level @ Ch: 07, PER: 28.80%, Count: 14			-89.00 dBm	✓
RX Level @ Ch: 08, PER: 30.60%, Count: 07			-91.50 dBm	✓
RX Level @ Ch: 09, PER: 29.00%, Count: 09			-91.60 dBm	✓
RX Level @ Ch: 10, PER: 30.60%, Count: 16			-91.50 dBm	✓
RX Level @ Ch: 11, PER: 29.70%, Count: 12			-91.10 dBm	✓
RX Level @ Ch: 12, PER: 30.20%, Count: 08			-91.00 dBm	✓
RX Level @ Ch: 13, PER: 29.70%, Count: 10			-90.90 dBm	✓
RX Level @ Ch: 14, PER: 30.70%, Count: 11			-91.00 dBm	✓
RX Level @ Ch: 15, PER: 30.10%, Count: 12			-88.80 dBm	✓
RX Level @ Ch: 16, PER: 29.10%, Count: 09			-90.80 dBm	✓
RX Level @ Ch: 17, PER: 29.60%, Count: 12			-91.10 dBm	✓
RX Level @ Ch: 18, PER: 29.60%, Count: 11			-90.50 dBm	✓
RX Level @ Ch: 19, PER: 28.80%, Count: 13			-90.70 dBm	✓
RX Level @ Ch: 20, PER: 29.40%, Count: 12			-91.10 dBm	✓
RX Level @ Ch: 21, PER: 29.70%, Count: 13			-91.20 dBm	✓
RX Level @ Ch: 22, PER: 29.90%, Count: 10			-91.20 dBm	✓
RX Level @ Ch: 23, PER: 30.20%, Count: 07			-88.30 dBm	✓
RX Level @ Ch: 24, PER: 30.90%, Count: 05			-91.20 dBm	✓
RX Level @ Ch: 25, PER: 29.40%, Count: 07			-91.50 dBm	✓
RX Level @ Ch: 26, PER: 29.70%, Count: 11			-91.20 dBm	✓
RX Level @ Ch: 27, PER: 29.70%, Count: 09			-90.80 dBm	✓
RX Level @ Ch: 28, PER: 28.90%, Count: 08			-90.70 dBm	✓
RX Level @ Ch: 29, PER: 30.40%, Count: 13			-90.70 dBm	✓
RX Level @ Ch: 30, PER: 29.30%, Count: 18			-90.50 dBm	✓
RX Level @ Ch: 31, PER: 31.40%, Count: 06			-88.20 dBm	✓
RX Level @ Ch: 32, PER: 28.90%, Count: 24			-90.70 dBm	✓
RX Level @ Ch: 33, PER: 30.00%, Count: 07			-90.60 dBm	✓
RX Level @ Ch: 34, PER: 29.00%, Count: 13			-90.70 dBm	✓
RX Level @ Ch: 35, PER: 28.80%, Count: 07			-90.00 dBm	✓
RX Level @ Ch: 36, PER: 28.90%, Count: 07			-90.60 dBm	✓
RX Level @ Ch: 37, PER: 30.80%, Count: 11			-91.00 dBm	✓
RX Level @ Ch: 38, PER: 31.80%, Count: 15			-90.90 dBm	✓
RX Level @ Ch: 39, PER: 31.00%, Count: 09			-87.60 dBm	✓

DA14580 Antenna module for QFN48 package

5.2 Transmitter output power (conducted)

5.2.1 Test description

In this test the conducted RF output power of the QFN48 antenna module was measured.

5.2.2 Test setup

The supply voltage (3.0 V DC) was connected between the PCB pads 27 (VBAT) and 26 (GND). The integrated antenna was bypassed by removing component R5. A short RF semi-rigid cable was connected to this pad. See [Figure 17](#).

The R&S®CBT Bluetooth® Tester from Rohde & Schwarz was used. Bursts of 10 packets were transmitted by the DA14580. The packet length was 37 bytes and the pattern was '01010101'.

5.2.3 Test results

The results of the output power measurements for one of the modules are given in [Figure 18](#).

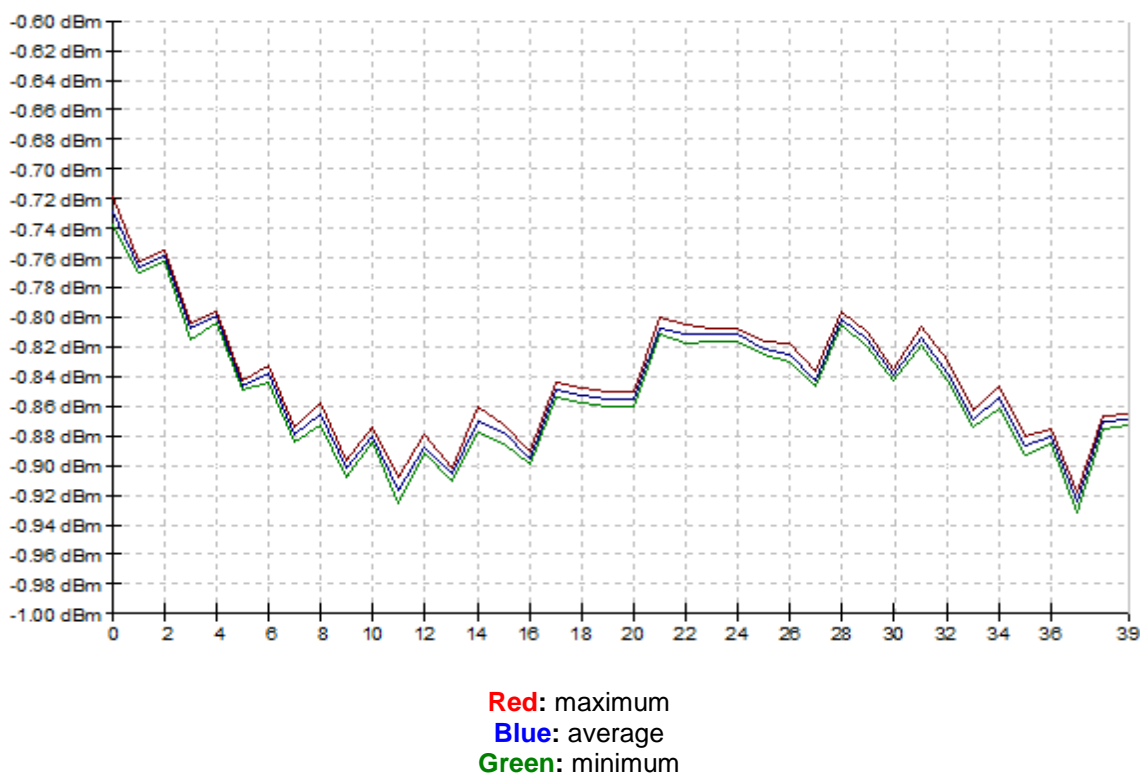

Figure 18: Conducted output power per channel

5.3 Current consumption

5.3.1 Test setup

The board used in the test presented has optimal RF performance. The following instruments were used for the test:

- Multimeter
- 3 V, 100 mA power source for peak current
- 3 V, 10 μ A power source for sleep current

DA14580 Antenna module for QFN48 package

- Agilent N6705B DC Power Analyzer

Power consumption was measured using beacon firmware. During this test the transmit peak current (in Advertising mode) and the sleep current were measured.

5.3.2 Test results

For this measurement the DUT was supplied by 3 V. Firmware was downloaded and the JTAG programmer was disconnected. The firmware was controlling the RF switches.

Table 11: Peak current during Advertising mode

Parameter	Value
I _{BAT_TX}	4.62 mA

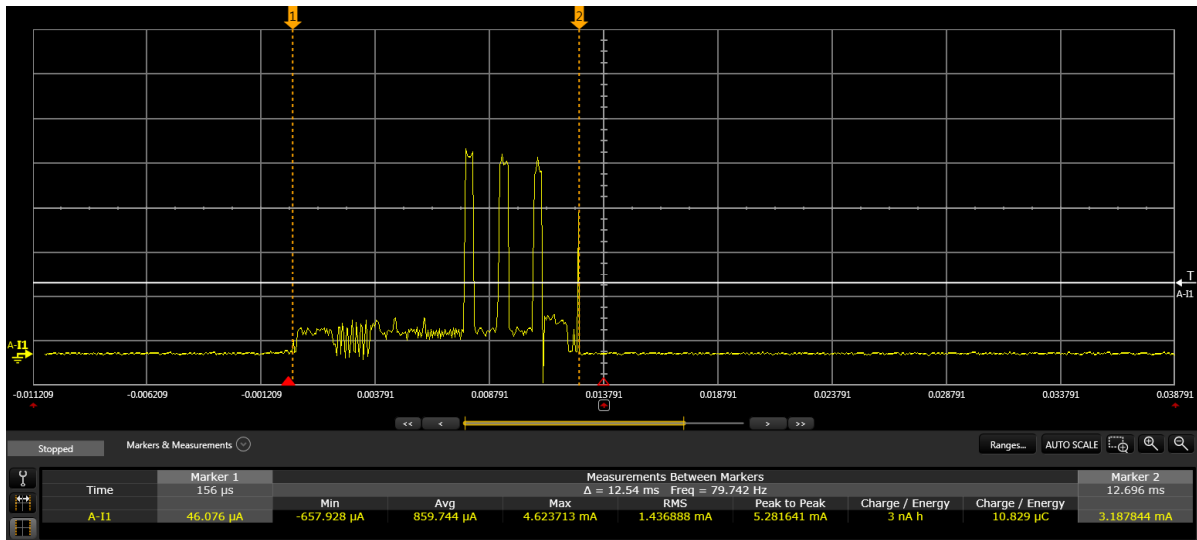

Figure 19: Supply current during an Advertising frame

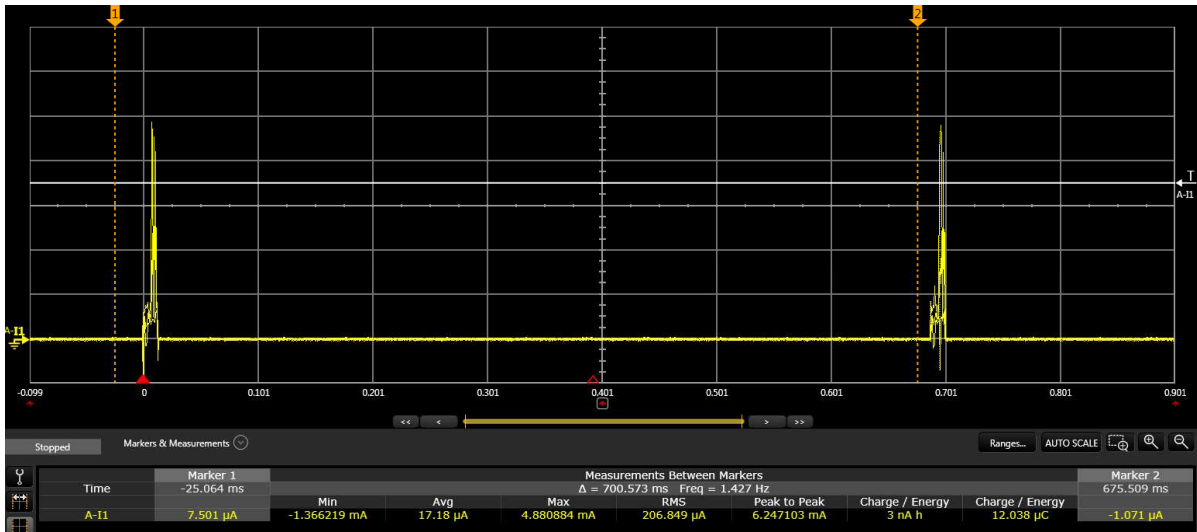

Figure 20: Supply current during periodic transmissions every 700 ms

DA14580 Antenna module for QFN48 package

Table 12: Average current in Extended Sleep mode

Parameter	Value
I _{BAT_SLP}	~ 2 μA

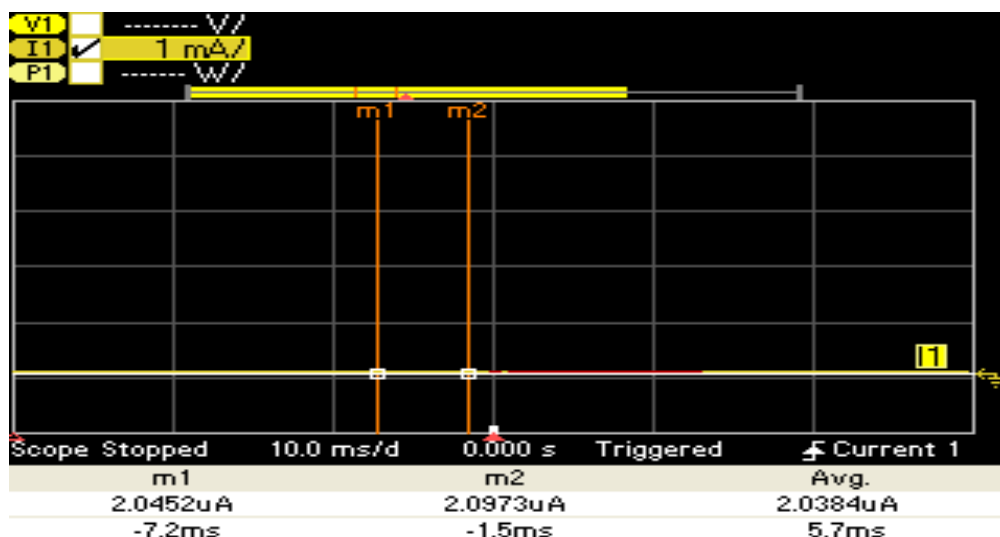

Figure 21: Supply current during Extended Sleep mode

DA14580 Antenna module for QFN48 package

6 FCC/IC Certification and CE marking

6.1 Standards and conformity assessment

The QFN48 antenna module was tested and found compliant by a qualified laboratory to the following standards:

For FCC/IC certification:

- Complete RF testing according to FCC part 15.247, 15.209.
- FCC Rules and Regulations 47 CFR Chapter I Part 15 Subpart B (10-01-12 Edition) and ICES-003 ISSUE 5. This covers:
 - Continuous Conducted Emission of Power Leads, frequency range 0.15 ÷ 30 MHz.
 - Radiated Emission – Electromagnetic field, frequency range 30 MHz ÷ 26 GHz

For CE marking:

- Complete RF testing according to ETSI EN 300 328 v1.8.1
- EMC testing according to EN 301 489-1 V.1.9.2 & EN 301 489-17 V2.2.1
 - Radiated Emission- Electromagnetic Field measure. Frequency Range 30 MHz ÷ 6 GHz. Test standard EN 55022 (2010)/ AC(2011).
 - Radiated RF Electromagnetic Field Immunity Test. Frequency Range 80 MHz ÷ 2.7 GHz. Test standard, EN 61000-4-3 (2006) / A1 (2008) / A2 (2010).
- Electrical Safety testing according to EN 61010-1: 2010
 - Electrostatic Discharge Immunity Test. Test standard EN 61000-4-2
- RoHS 2011/65/CE (includes screening for 20 elements).

DA14580 Antenna module for QFN48 package

6.2 FCC requirements regarding the end product and end user**6.2.1 End product marking**

The end product that the module is integrated into must be marked as follows:

“Contains Transmitter Module FCC ID: Y82DA14580REFANT / IC: 9567A-DA14580REFANT”

“Module transmetteur ID IC: 9567A-DA14580REFANT”

6.2.2 End product literature

The literature that is provided to the end user must include the following wording:

“Dialog Semiconductor does not approve any changes or modifications made to this device by the user. Any changes or modifications could void the user’s authority to operate the equipment.

Dialog Semiconductor n’approuve aucune modification apportée à l’appareil par l’utilisateur, quelle qu’en soit la nature. Tout changement ou modification peuvent annuler le droit d’utilisation de l’appareil par l’utilisateur.

This device complies with Part 15 of the FCC Rules and Industry Canada licence-exempt RSS standard(s). Operation is subject to the following two conditions: (1) this device may not cause interference, and (2) this device must accept any interference, including interference that may cause undesired operation of the device.

Le présent appareil est conforme aux CNR d’Industrie Canada applicables aux appareils radio exempts de licence. L’exploitation est autorisée aux deux conditions suivantes : (1) l’appareil ne doit pas produire de brouillage, et (2) l’utilisateur de l’appareil doit accepter tout brouillage radioélectrique subi, même si le brouillage est susceptible d’en compromettre le fonctionnement.

This device complies with FCC/IC radiation exposure limits set forth for an uncontrolled environment and meets the FCC radio frequency (RF) Exposure Guidelines and RSS-102 of the IC radio frequency (RF) Exposure rules. This transmitter must not be co-located or operating in conjunction with any other antenna or transmitter.

Le présent appareil est conforme à l’exposition aux radiations FCC / IC définies pour un environnement non contrôlé et répond aux directives d’exposition de la fréquence de la FCC radiofréquence (RF) et RSS-102 de la fréquence radio (RF) IC règles d’exposition. L’émetteur ne doit pas être colocalisé ni fonctionner conjointement avec à autre antenne ou autre émetteur.

This equipment has been tested and found to comply with the limits for a Class B digital device, pursuant to part 15 of the FCC Rules. These limits are designed to provide reasonable protection against harmful interference in a residential installation.

This equipment generates, uses and can radiate radio frequency energy and, if not installed and used in accordance with the instructions, may cause harmful interference to radio communications. However, there is no guarantee that interference will not occur in a particular installation.

If this equipment does cause harmful interference to radio or television reception, which can be determined by turning the equipment off and on, the user is encouraged to try to correct the interference by one or more of the following measures:

- Reorient or relocate the receiving antenna.
- Increase the separation between the equipment and receiver.
- Connect the equipment into an outlet on a circuit different from that to which the receiver is connected.
- Consult the dealer or an experienced radio/TV technician for help.”

DA14580 Antenna module for QFN48 package

6.3 Industry Canada requirements regarding the end product and end user

6.3.1 End product marking

The host device shall be properly labelled to identify the modules within the host device. The Industry Canada certification label of a module shall be clearly visible at all times when installed in the host device, otherwise the host device must be labelled to display the Industry Canada certification number of the module, preceded by the words "Contains transmitter module", or the word "Contains", or similar wording expressing the same meaning, as follows:

"Contains transmitter module IC: 9567A-DA14580REFANT"

L'appareil hôte doit être étiqueté comme il faut pour permettre l'identification des modules qui s'y trouvent. L'étiquette de certification d'Industrie Canada d'un module donné doit être posée sur l'appareil hôte à un endroit bien en vue en tout temps. En l'absence d'étiquette, l'appareil hôte doit porter une étiquette donnant le numéro de certification du module d'Industrie Canada, précédé des mots "Contient un module d'émission", du mot "Contient" ou d'une formulation similaire exprimant le même sens, comme suit:

"Contient le module d'émission IC: 9567A-DA14580REFANT"

6.3.2 End product literature

The literature that is provided to the end user must include the following wordings:

"This device complies with Industry Canada licence-exempt RSS standard(s). Operation is subject to the following two conditions: (1) this device may not cause interference, and (2) this device must accept any interference, including interference that may cause undesired operation of the device.

Le présent appareil est conforme aux CNR d'Industrie Canada applicables aux appareils radio exempts de licence. L'exploitation est autorisée aux deux conditions suivantes : (1) l'appareil ne doit pas produire de brouillage, et (2) l'utilisateur de l'appareil doit accepter tout brouillage radioélectrique subi, même si le brouillage est susceptible d'en compromettre le fonctionnement."

CAN ICES-3 (B) / NMB-3 (B)

"This Class B digital apparatus complies with Canadian ICES-003.

Cet appareil numérique de classe B est conforme à la norme canadienne ICES-003."

6.4 1999/5/EC Directive

This device has been evaluated against the essential requirements of the 1999/5/EC Directive.

Bulgarian	С настоящето Dialog Semiconductor BV декларира, че QFN48 BLUETOOTH MODULE отговаря на съществените изисквания и другите приложими изисквания на Директива 1999/5/EC.
Czech	Dialog Semiconductor BV tímto prohlašuje, že tento QFN48 BLUETOOTH MODULE je ve shodě se základními požadavky a dalšími příslušnými ustanoveními směrnice 1999/5/ES.
Danish	Undertegnede Dialog Semiconductor BV erklærer herved, at følgende udstyr QFN48 BLUETOOTH MODULE overholder de væsentlige krav og øvrige relevante krav i direktiv 1999/5/EF.

DA14580 Antenna module for QFN48 package

Dutch	Hierbij verklaart Dialog Semiconductor BV dat het toestel QFN48 BLUETOOTH MODULE in overeenstemming is met de essentiële eisen en de andere relevante bepalingen van richtlijn 1999/5/EG.
English	Hereby, Dialog Semiconductor BV, declares that this QFN48 BLUETOOTH MODULE is in compliance with the essential requirements and other relevant provisions of Directive 1999/5/EC.
Estonian	Käesolevaga kinnitab Dialog Semiconductor BV seadme QFN48 BLUETOOTH MODULE vastavust direktiivi 1999/5/EÜ põhinõuetele ja nimetatud direktiivist tulenevatele teistele asjakohastele sätetele.
German	Hiermit erklärt Dialog Semiconductor BV, dass sich das Gerät QFN48 BLUETOOTH MODULE in Übereinstimmung mit den grundlegenden Anforderungen und den übrigen einschlägigen Bestimmungen der Richtlinie 1999/5/EG befindet.
Greek	ΜΕ ΤΗΝ ΠΑΡΟΥΣΑ Dialog Semiconductor BV ΔΗΛΩΝΕΙ ΟΤΙ QFN48 BLUETOOTH MODULE ΣΥΜΜΟΡΦΩΝΕΤΑΙ ΠΡΟΣ ΤΙΣ ΟΥΣΙΩΔΕΙΣ ΑΠΑΙΤΗΣΕΙΣ ΚΑΙ ΤΙΣ ΛΟΙΠΕΣ ΣΧΕΤΙΚΕΣ ΔΙΑΤΑΞΕΙΣ ΤΗΣ ΟΔΗΓΙΑΣ 1999/5/EK.
Hungarian	Alulírott, Dialog Semiconductor BV nyilatkozom, hogy a QFN48 BLUETOOTH MODULE megfelel a vonatkozó alapvető követelményeknek és az 1999/5/EC irányelv egyéb előírásainak.
Finnish	Dialog Semiconductor BV vakuuttaa täten että QFN48 BLUETOOTH MODULE tyyppinen laite on direktiivin 1999/5/EY oleellisten vaatimusten ja sitä koskevien direktiivin muiden ehtojen mukainen.
French	Par la présente Dialog Semiconductor BV déclare que l'appareil QFN48 BLUETOOTH MODULE est conforme aux exigences essentielles et aux autres dispositions pertinentes de la directive 1999/5/CE.
Icelandic	Hér með lýsir Dialog Semiconductor BV yfir því að QFN48 BLUETOOTH MODULE er í samræmi við grunnkröfur og aðrar kröfur, sem gerðar eru í tilskipun 1999/5/EC
Italian	Con la presente Dialog Semiconductor BV dichiara che questo QFN48 BLUETOOTH MODULE è conforme ai requisiti essenziali ed alle altre disposizioni pertinenti stabilite dalla direttiva 1999/5/CE.
Latvian	Ar šo Dialog Semiconductor BV deklarē, ka QFN48 BLUETOOTH MODULE atbilst Direktīvas 1999/5/EK būtiskajām prasībām un citiem ar to saistītajiem noteikumiem.
Lithuanian	Šiuo Dialog Semiconductor BV deklaruoja, kad šis QFN48 BLUETOOTH MODULE atitinka esminius reikalavimus ir kitas 1999/5/EB Direktyvos nuostatas.
Maltese	Hawnhekk, Dialog Semiconductor BV, jiddikjara li dan QFN48 BLUETOOTH MODULE jikkonforma mal-ħtiġijiet essenzjali u ma provvedimenti oħrajn rilevanti li hemm fid-Dirrettiva 1999/5/EC.
Norwegian	Dialog Semiconductor BV erklærer herved at utstyret QFN48 BLUETOOTH MODULE er i samsvar med de grunnleggende krav og øvrige relevante krav i direktiv 1999/5/EF.

DA14580 Antenna module for QFN48 package

Polish	Niniejszym Dialog Semiconductor BV oświadcza, że QFN48 BLUETOOTH MODULE jest zgodny z zasadniczymi wymogami oraz pozostałymi stosownymi postanowieniami Dyrektywy 1999/5/EC
Portuguese	Dialog Semiconductor BV declara que este QFN48 BLUETOOTH MODULE está conforme com os requisitos essenciais e outras disposições da Directiva 1999/5/CE.
Slovak	Dialog Semiconductor BV týmto vyhlasuje, že QFN48 BLUETOOTH MODULE spĺňa základné požiadavky a všetky príslušné ustanovenia Smernice 1999/5/ES.
Slovenian	Dialog Semiconductor BV izjavlja, da je ta QFN48 BLUETOOTH MODULE v skladu z bistvenimi zahtevami in ostalimi relevantnimi določili direktive 1999/5/ES.
Spanish	Por medio de la presente Dialog Semiconductor BV declara que QFN48 BLUETOOTH MODULE cumple con los requisitos esenciales y cualesquiera otras disposiciones aplicables o exigibles de la Directiva 1999/5/CE.
Swedish	Härmed intygar Dialog Semiconductor BV att denna QFN48 BLUETOOTH MODULE står i överensstämmelse med de väsentliga egenskapskrav och övriga relevanta bestämmelser som framgår av direktiv 1999/5/EG.

In order to satisfy the essential requirements of 1999/5/EC Directive, the product is compliant with the following standards:

RF spectrum use (R&TTE art. 3.2)	EN 300 328 v1.8.1
EMC (R&TTE art. 3.1b)	EN 301 489-1 V1.9.2 EN 301 489-17 V2.2.1
Health & Safety (R&TTE art. 3.1a)	EN 60950-1:2006 + A11:2009 + A1:2010 + A12:2011 + AC:2011 EN 62479:2010

The conformity assessment procedure referred to in Article 10 and detailed in Annex IV of Directive 1999/5/EC has been followed with the involvement of the following Notified Body:

AT4 wireless, S.A.

Parque Tecnológico de Andalucía

C/ Severo Ochoa 2

29590 Campanillas – Málaga

SPAIN

Notified Body No: 1909

Thus, the following marking is included in the product:

CE 1909

Full declaration of conformity can be found can be found on the customer portal <https://support.diasemi.com/>

There is no restriction for the commercialisation of this device in all the countries of the European Union.

6.4.1 RoHS compliance

Dialog Semiconductor complies to European Directive 2001/95/EC and from 2 January 2013 onwards to European Directive 2011/65/EU concerning Restriction of Hazardous Substances (RoHS/RoHS2). Dialog Semiconductor's statement on RoHS can be found on the customer portal <https://support.diasemi.com/>. RoHS certificates from our suppliers are available on request.

7 Revision history

Revision	Date	Description
1.0	21-Oct-2014	Initial version.
2.0	10-Dec-2014	1999/5/EC Directive added

DA14580 Antenna module for QFN48 package

Status definitions

Status	Definition
DRAFT	The content of this document is under review and subject to formal approval, which may result in modifications or additions.
APPROVED or unmarked	The content of this document has been approved for publication.

Disclaimer

Information in this document is believed to be accurate and reliable. However, Dialog Semiconductor does not give any representations or warranties, expressed or implied, as to the accuracy or completeness of such information. Dialog Semiconductor furthermore takes no responsibility whatsoever for the content in this document if provided by any information source outside of Dialog Semiconductor.

Dialog Semiconductor reserves the right to change without notice the information published in this document, including without limitation the specification and the design of the related semiconductor products, software and applications.

Applications, software, and semiconductor products described in this document are for illustrative purposes only. Dialog Semiconductor makes no representation or warranty that such applications, software and semiconductor products will be suitable for the specified use without further testing or modification. Unless otherwise agreed in writing, such testing or modification is the sole responsibility of the customer and Dialog Semiconductor excludes all liability in this respect.

Customer notes that nothing in this document may be construed as a license for customer to use the Dialog Semiconductor products, software and applications referred to in this document. Such license must be separately sought by customer with Dialog Semiconductor.

All use of Dialog Semiconductor products, software and applications referred to in this document are subject to Dialog Semiconductor's [Standard Terms and Conditions of Sale](#), unless otherwise stated.

© Dialog Semiconductor. All rights reserved.

RoHS Compliance

Dialog Semiconductor complies to European Directive 2001/95/EC and from 2 January 2013 onwards to European Directive 2011/65/EU concerning Restriction of Hazardous Substances (RoHS/RoHS2).

Dialog Semiconductor's statement on RoHS can be found on the customer portal <https://support.diasemi.com/>. RoHS certificates from our suppliers are available on request.

Contacting Dialog Semiconductor

United Kingdom (Headquarters)

Dialog Semiconductor PLC

Phone: +44 1793 757700

Germany

Dialog Semiconductor GmbH

Phone: +49 7021 805-0

The Netherlands

Dialog Semiconductor B.V.

Phone: +31 73 640 8822

Email:

enquiry@diasemi.com

North America

Dialog Semiconductor Inc.

Phone: +1 408 845 8500

Japan

Dialog Semiconductor K. K.

Phone: +81 3 5425 4567

Taiwan

Dialog Semiconductor Taiwan

Phone: +886 281 786 222

Web site:

www.dialog-semiconductor.com

Singapore

Dialog Semiconductor Singapore

Phone: +65 64 849929

China

Dialog Semiconductor China

Phone: +86 21 5178 2561

Korea

Dialog Semiconductor Korea

Phone: +82 2 3469 8291