

# PCX924e

# PCX924e-Mic

# PCX22e

*Professional Stereo Sound Cards*



*User's manual*

**For technical support,  
please contact your system supplier**



**Digigram S.A.**

*Parc de Pré Milliet, 38330 Montbonnot - FRANCE*

*Tel: +33 (0)4 76 52 55 01 • Fax: +33 (0) 4 76 52 53 07 • E-mail: [info@digigram.com](mailto:info@digigram.com)*

**Digigram Inc.**

*2000 North 14th Street - Suite 530, Arlington, VA 22201-USA*

*Tel: +1 703 875 9100 • Fax: +1 703 875 9161 • E-mail: [input@digigram.com](mailto:input@digigram.com)*

**Digigram Asia Pte Ltd.**

*350 Orchard Road - #19-07 Shaw House Singapore, 238868-SINGAPORE*

*Tel: +65 6291 2234 • Fax: +65 6291 3433 • E-mail: [info\\_asia@digigram.com](mailto:info_asia@digigram.com)*

### Table of Contents

<b>INFORMATION FOR THE USER</b> .....	5
<b>IMPORTANT NOTICE</b> .....	6
<b>CONTENTS OF THIS PACKAGE</b> .....	6
<b>FEATURES</b> .....	6
PCX924e & PCX924e-Mic Main hardware features.....	6
PCX924e-Mic Additional hardware features.....	7
PCX22e - Main hardware features.....	7
PCX924e, PCX924e-Mic, and PCX22e Main software features.....	8
<b>REQUIREMENTS</b> .....	9
Minimum hardware requirements.....	9
Software requirements.....	9
Supported operating systems.....	9
<b>HARDWARE INSTALLATION</b> .....	9
Installing the card.....	9
Interrupt and memory address.....	9
<b>SOFTWARE INSTALLATION</b> .....	10
Standard installation under Windows XP, Server 2003, and Windows Vista.....	10
Parameterizing the ASIO driver.....	12
Parameterizing the Wave driver.....	12
Removing the driver under Windows XP, and Windows Server 2003.....	13
Removing the driver under Windows Vista.....	13
<b>HOW TO CHECK THE INSTALLATION</b> .....	13
<b>THE 'DIGIGRAM HARDWARE SETTINGS' ('DHS')</b>	
<b>CONTROL PANEL</b> .....	14
<b>SPECIFICATIONS</b> .....	15
Configuration.....	15
Inputs.....	15
Additional functionalities – PCX924e-Mic.....	16
Outputs.....	16
Connectors.....	16
Audio specifications.....	17
Analog audio performance.....	17
Sample rate converter performance.....	17
Analog mono microphone input features - PC924e-Mic.....	18
AES42 microphone input features - PCX924e-Mic.....	18
Development environments.....	18

<b>APPENDICES</b> .....	19
PCX924e - Schematic Diagram.....	19
PCX924e-Mic - Schematic Diagram .....	19
PCX22e - Schematic Diagram .....	19
PCX924e & PCX924-Mic - Layout .....	20
PCX22e - Layout.....	20
PCX924e - analog cable diagram:.....	21
PCX924e-Mic - analog cable diagram:.....	21
PCX924e - Wiring Diagram - analog cable .....	22
PCX924e-Mic - Wiring Diagram - analog cable.....	22
PCX924e & PCX924e-Mic digital cable with GPIOs.....	23
PCX924e & PCX924-Mic- digital cable without GPIOs.....	23
PCX924e & PCX924e-Mic - Wiring Diagram	
- digital cable with GPIOs.....	24
PCX924e & PCX924e-Mic - Wiring Diagram	
- digital cable without GPIOs.....	24
PCX22e - analog cable diagram.....	25
PCX22e - Wiring Diagram - analog cable.....	25
PCX22e - digital cable with GPIOs.....	26
PCX22e - digital cable without GPIOs.....	26
PCX22e - Wiring Diagram - digital cable with GPIOs.....	27
PCX22e - Wiring Diagram - digital cable without GPIOs.....	27
PCX924e - cable pinout.....	28
PCX924e-Mic - cable pinout.....	28
PCX22v2 - cable pinout.....	29

# PCX924e & PCX924e-Mic, PCX22e

## User's Manual

### INFORMATION FOR THE USER

This device complies with part 15 of FCC rules. Operation is subject to the following two conditions: (1) This device may not cause harmful interference, and (2) This device must accept any interference received, including interference that may cause undesired operation.

This equipment has been tested and found to comply with the limits for a CLASS B digital device, pursuant to Part 15 of the FCC Rules. These limits are designed to provide reasonable protection against harmful interference in a residential installation. This equipment generates, uses, and can radiate radio frequency energy and, if not installed and used in accordance with the instructions contained in this data sheet, may cause harmful interference to radio and television communications. However, there is no guarantee that interference will not occur in a particular installation.

If this equipment does cause harmful interference to radio or television reception, which can be determined by turning the equipment off and on, the user is encouraged to try to correct the interference by one or more of the following measures:

- \* reorient or relocate the receiving antenna
- \* increase the separation between the equipment and the receiver
- \* connect the equipment into an outlet on a circuit different from that of the receiver
- \* consult the dealer or an experienced audio television technician.

**Note:** *Connecting this device to peripheral devices that do not comply with CLASS B requirements or using an unshielded peripheral data cable could also result in harmful interference to radio or television reception. The user is cautioned that any changes or modifications not expressly approved by the party responsible for compliance could void the user's authority to operate this equipment. To ensure that the use of this product does not contribute to interference, it is necessary to use shielded I/O cables.*

#### **Warning:**

Electrostatic discharge (ESD) can damage several components on the board. To avoid such damage in handling the board, take the following precautions:

Bring the device and everything that contacts it to ground potential by providing a conductive surface and discharge paths. As a minimum, observe these precautions:

- Disconnect all power and signal sources.
- Place the device on a grounded conductive work surface.
- Ground yourself via a grounding wrist strap or by holding a grounded object.
- Ground any tool that will contact the device.

**Due to the reduced length of the PCI EXPRESS™ bus connector and the resulting lack of mechanical stability, we strongly advise against transporting the card(s) installed in a computer, unless its chassis or case provides a dedicated support to keep the card securely in place in order to avoid physical damage.**

## IMPORTANT NOTICE

---

This card has been tested and found to comply with the following standards:

- International: CISPR22 Class B.
- Europe: EMC 89/336/CEE (1992) specifications, RoHS compliant.
- United States: FCC Rules-Part 15-Class B (digital device).

In order to guarantee compliance with the above standards in an installation, the following must be done:

- the provided cable must not be modified.
- additional cables used must have their respective shield connected to each extremity.

## CONTENTS OF THIS PACKAGE

---

Thank you for purchasing a Digigram PCX card.

The package consists of the following components:

- a PCX924e, PCX924e-Mic, or PCX22e sound card,
- the User's Manual at hand.

*The breakout cables to connect the card's I/Os are not part of this package. They are delivered separately.*

## FEATURES

---

PCX924e-Mic, PCX924e, and PCX22e are audio cards for PCI EXPRESS™ (PCIe®) bus. They are in PCI EXPRESS™ x1 format and can thus be plugged into any PCIe® slot (x1, x2, x4, x8, x16, x32).

### PCX924e & PCX924e-Mic

#### Main hardware features

- 2 balanced\* analog mono line inputs, with software adjustable gain and a maximum Input level of +24 dBu
- 2 servo-balanced\*\* analog mono line outputs, with software adjustable gain and a maximum output level of +24 dBu

---

\* can be used with unbalanced signals

\*\* electronically servo-balanced outputs provide automatic level adjustment to accommodate either balanced or unbalanced lines

# PCX924e & PCX924e-Mic, PCX22e

## User's Manual

- 1 AES/EBU<sup>\*\*\*</sup> stereo input  
This input features a hardware sample rate converter (for details see chapter 'Specifications')  
The selection of the digital input for recording excludes the selection of the analog inputs.  
It is possible to use the signal on the digital input as reference clock.
- 1 AES/EBU Sync input
- These two AES/EBU inputs allow:
  - recording of a digital signal on the AES/EBU data input; this input is also used as source of synchronization with a digital clock
  - recording of a digital signal on the AES/EBU data input, synchronized on a digital clock connected to the AES/EBU synchronization input;
  - the synchronization of analog recording and playback on an AES/EBU clock connected to the AES/EBU Sync input.
- 1 AES/EBU<sup>\*\*\*</sup> stereo output  
Always transmits the digital version of the analog outputs 1 and 2.
- 1 LTC (Linear Time Code) input
- 1 mini jack stereo headphone output  
This output is in parallel of the analog outputs 1 and 2.
- 2 General Purpose inputs and 2 outputs (GPIOs)
- Inter-card synchronization connector

## PCX924e-Mic

### Additional hardware features

- 1 analog microphone input with
  - high-quality preamplifier
  - switchable 48 V phantom power
  - analog expander/compressor/limiterThis input is mixed with the two line inputs before A/D conversion.
- The AES/EBU input is AES42 compatible (for details see chapter 'Specifications')

**Note:** AES42 is an extension of the digital audio standard of interface AES3 providing for interfacing digital microphones.

## PCX22e - Main hardware features

- 2 servo-balanced\* analog mono line outputs, with software adjustable gain and a maximum output level of +24 dBu

---

<sup>\*\*\*</sup> can be used as S/PDIF interface as well

\* electronically servo-balanced outputs provide automatic level adjustment to accommodate either balanced or unbalanced lines

- 1 AES/EBU\* synchronization input, for synchronization on an external clock
- 1 AES/EBU\* stereo output  
(Always plays the digital version of the analog outputs 1 and 2)
- 1 LTC (Linear Time Code) input
- 1 mini jack stereo headphone output  
(This output is in parallel of the analog outputs 1 and 2)
- 2 General Purpose inputs and 2 outputs (GPIOs)

## PCX924e, PCX924e-Mic, and PCX22e

### Main software features

- Real-time, simultaneous record and playback in PCM (8, 16 and 24 bits) as well as in MPEG Audio Layer I, Layer II and Layer III<sup>Ⓛ</sup>, Float IEEE754 conversion supported (with 24-bit fixed-point dynamic range)
- When using the np SDK, real-time mixing of several PCM and MPEG audio streams, direct monitoring, level adjustment, panning, cross-fades, punch-in/punch-out, scrubbing, time-stretching, pitch-shifting, 3-band parametric equalizer, maximizer, format and frequency conversions
- Low latency DirectSound, ASIO, and Wave\*\* drivers. Under DirectSound and ASIO, the cards operate in PCM mode only (nevertheless, an application can integrate coders/decoders on the host PC). Under Wave, the boards can operate in both PCM and MPEG (layer 1 and layer 2).  
<sup>Ⓛ</sup> MPEG Layer III play-only on DSP;  
MPEG Layer III recording on the host computer is available through Digigram's PC Codec option using the np SDK

**Note:** *the HR Runtime package for Windows Vista does not include a Wave driver. In case your audio application explicitly requires a Wave interface, a Wave driver is available on request. In this case, please contact [Digigram](http://www.digigram.com).*

---

\* can be used as S/PDIF interface as well

\*\* Windows XP and Server 2003 only



# PCX924e & PCX924e-Mic, PCX22e

---

## User's Manual

### REQUIREMENTS

---

#### Minimum hardware requirements

PC with one free PCI EXPRESS™ (PCIe®) slot (x1, x2, x4, x8, x16 or x32). CPU power and memory required depend on the operating system and on the audio application used.

#### Software requirements

To use your PCX924e, PCX924e-Mic or PCX22e, install the driver from the np Runtime HR package version 1.70 or higher.

This package includes:

- a Digigram np driver enabling OEM applications to best capitalize on the boards
- a WDM DirectSound driver
- an ASIO driver (installation optional)
- a Wave driver\* (installation optional)

#### Supported operating systems

PCX924e, PCX924e-Mic, and PCX22e cards run under Windows XP\*\*, Windows Server 2003\*\* and Windows Vista\*\*.

### HARDWARE INSTALLATION

---

***Due to the reduced length of the PCI EXPRESS™ bus connector and the resulting lack of mechanical stability, we strongly advise against transporting the card(s) installed in a computer, unless its chassis or case provides a dedicated support to keep the card securely in place in order to avoid physical damage.***

The card has to be installed in the computer prior to installing its driver.

#### Installing the card

Gently plug the card in a free PCIe® slot and press it down to position it firmly. Tighten the screw.

#### Interrupt and memory address

Hardware interrupt and addresses are automatically set up at start-up by the PCI PnP BIOS.

---

\* Windows XP and Server 2003 only

\*\* 32-bit version

## SOFTWARE INSTALLATION

---

**Note:** *the installation of the software requires administrator rights on your computer*

Please visit the Digigram web site at [www.digigram.com](http://www.digigram.com) for the most recent driver.

In case you run a specific application developed or installed by a Digigram partner, it might require the use of a specific driver version. In this case, make sure that the updated driver has been approved by your supplier.

### **Standard installation under Windows XP, Server 2003, and Windows Vista**

The following installation procedure allows to install the selected drivers and the DHS application (see Digigram Hardware Settings in this manual). In this case, only a few controls are accessible from the Microsoft Volume control panel, or from the DirectSound software entry points.

***Important note:*** *this default procedure installs the 'Digigram Hardware Settings' control panel. This application allows the configuration of the hardware resources of Digigram cards for all audio applications. The DHS allows for instance to define the clock of the card, the input source, input and output analog and digital gain, Sample Rate Converters, digital output format, etc...*

*Please note that, with the DHS installed, controls available through the DirectSound control panel are limited to:*

- *Volume control for input and output*
- *Wave control*

*Under Windows XP, and Server 2003 you may also install the driver without installing the DHS control panel, and in this case more controls are available through the DirectSound control panel:*

- *Volume control for input*
- *Wave control*
- *Monitoring control*
- *Analog input level*
- *Digital input level*
- *Clock selection: AES Sync, AES I, Word Clock*
- *Digital output format: professional, consumer*

*To do so, install the driver with the command line: "**setup x\_topology**" (not available under Windows Vista). For detailed information, please refer to the dedicated document on our web site.*

- *Shut down your computer and insert your PCX card.*

# PCX924e & PCX924e-Mic, PCX22e

---

## User's Manual

- Restart your computer.
- Click on **Cancel** if the “**Found New Hardware**” Wizard appears.
- Double-click on the **HR Runtime vxx.msi/HR Runtime vxx.msi for Vista** icon to launch the driver installation.
- A welcome message is displayed, click **Next** to continue.
- The “**License Agreement**” window appears: read it, and click on “**I accept the terms in the license agreement**” to approve it.
- Do the same in the next window for Virtual PCX and PC Codec Legal Notice.
- In the “**Custom Setup**” window, the “*Drivers for the HR boards*” are displayed; by default, both WDM DirectSound and ASIO HR are installed.  
To install the Wave driver\*, select ‘**Wave**’.  
**Next.**
- In the “**Ready to Install the Program**” Window, click on **Install** to start copying the files.
  - **Note:** *In case you use an unsigned driver version, the “Digital Signature Not Found” message may appear because a non-Microsoft software is about to be installed. Click on **Continue** in the “Hardware installation” window (Windows XP, Server 2003).*
- Under Windows Vista:  
Click **Allow** in the “**User Account Control**” window.  
Click **Install** in the “**Windows Security**” window.
- In the “**Digigram drivers**” window, select the number and the size of buffers required by your applications. Click on **Ok**.
- Click **Finish** to complete the driver installation.

---

\* Windows XP and Server 2003 only; for Windows Vista, a Wave driver is available on request.

## Parameterizing the ASIO driver

To use the ASIO driver on your PCX sound card, the option “PCM only” has to be activated in the Digigram control panel (CPL). To access this control panel, go to <Start>, <Programs>, <Digigram>, <Digigram Control Center>. For detailed information on how to use the Digigram control panel, please refer to its online help (“? Help” button).

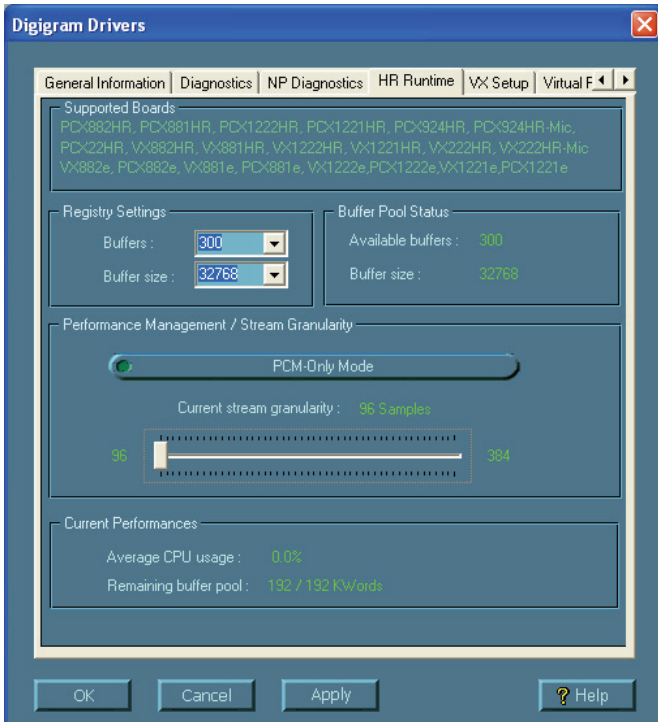

## Parameterizing the Wave driver

In the case of an application managing exclusively PCM audio, the latency of the Wave driver can be optimized activating the option “PCM only” in the Digigram control panel (CPL). With this option enabled, the latency of the Wave driver is optimized (in this case the PCX on-board MPEG encoding/decoding is disabled). To access this control panel, go to <Start>, <Programs>, <Digigram>, <Digigram Control Center>. For detailed information on how to use the Digigram control panel, please refer to its online help (“? Help” button).

# PCX924e & PCX924e-Mic, PCX22e

## User's Manual

---

### Removing the driver under Windows XP, and Windows Server 2003

- Open the Windows Control Panel and double-click on the **Add/Remove Software** icon.
- Select **Digigram HR Runtime ...**, and **Change/Remove**.
- Select **Remove** in the “**HR Runtime**” window.
- Follow the instructions to finish the driver removal.

### Removing the driver under Windows Vista

- Open the **Windows Control Panel** and double-click on the **Programs and Features** icon.
- Select “**Digigram HR Runtime for Vista...**”, and **Change/Remove**.
- Select **Remove** in the “**HR Runtime**” window.
- Follow the instructions to finish removing the driver.

### How to check the installation

---

Once the cards and the driver have been installed according to the procedure described in this manual, you can verify that the card is properly installed and works fine as follows:

- Menu <Start> <Settings> <Control panel>, <Sound and Multimedia>, tab “**Audio**”, **Default device** (Playback device, Recording device). The card's channels can be selected. The card can be used with any *DirectSound* application.
- The card is also visible via the np interface: go to <Start> <Programs> <Digigram> and select <Digigram Control Center>.
  - In the “**Digigram drivers**” window, select the ‘**General Information**’ tab.  
In the “**Modules Information**” window, you can see the **HR Runtime** modules that have been installed, and their versions.
  - In the “**Digigram drivers**” window, select the ‘**Diagnostics**’ tab.  
You should see here the icons of the cards you have installed.
  - If the card you have installed is listed:
    - Right click on the icon of the card.
    - Select ‘**Diagnostics**’, and **Play Sine**. This plays in loop a sine signal on the outputs of the card. You can also select **Play file** to play in loop a file of your choice (PCM only). If the playback is correct, the card is correctly installed and works.
    - To stop the playback, right click on the card icon, and select **Stop Activities**.

- If the card is not displayed:
  - Make sure that during the HR runtime installation the “**Driver for the HR boards**” has been selected in the “**Select components**” window.
  - Make sure that the card is correctly inserted in the PCI slot, and screwed on the PC chassis.
  - If necessary, uninstall the HR runtime package as described in this manual, and re-install it.
- If the Wave driver has been installed\*:
  - Go to menu <Start>, <Settings>, <Control panel>, <Sound and Multimedia>, tab “Audio”, Default device (Playback device, Recording device). The card’s channels can be selected. The card can be used with any Wave application.
- If the ASIO driver has been installed:
  - The card is visible from any ASIO application.

## The ‘Digigram Hardware Settings’ (‘DHS’) control panel

---

Digigram Hardware Settings (DHS) is an application allowing to configure the hardware resources of Digigram cards for all audio applications using them. This application is installed by default with the driver unless the command line “*setup x\_topology*” has been executed to install the driver.

A resource being managed by the DHS application can not be modified by any other applications. To enable an audio application to modify a Digigram card resource, this resource must not be managed by the DHS.

**Note:** *As soon as a resource of a card is managed by the DHS, the clock selection of this card MUST be defined in the DHS.*

The DHS allows to:

- Select the clock the card uses
- Select of the input source
- Adjust analog and digital gains of inputs and outputs
- Enable Sample Rate Converters of an input
- Select the input monitored on an output
- Set the monitoring gains
- Define the digital output format

*For more detailed information on how to use this control panel, please refer to its on-line help.*

---

\* Windows XP and Server 2003 only; for Vista, a Wave driver is available on request.

# PCX924e & PCX924e-Mic, PCX22e

## User's Manual

### SPECIFICATIONS

#### Configuration

	PCX924e	PCX924e-Mic	PCX22e
Bus/Format	PCI EXPRESS™ (PCIe <sup>®</sup> ) x1 (x2, x4, x8, x16, x32 compatible)		
Digital Signal Processor	Motorola 56303 at 100 MHz		
RAM	512 kWords		
Size	168 mm x 99 mm x 20 mm		
Power requirements (+3.3V/ +12V)	1 A / 0.2 A	1.3 A* / 0,22 A	0.92 A / 0.18 A
Operating: temp / humidity (non-condensing)	0°C / +50°C • 5% / 90%		
Storage: temp / humidity (non-condensing)	-5°C / +70°C • 0% / 95%		

#### Inputs

	PCX924e	PCX924e-Mic	PCX22e
Analog line inputs (mono)	2 balanced**		-
Maximum input level/impedance	+24 dBu / >10 kΩ		-
Digital inputs (stereo)	1 AES/EBU*** with hardware sample rate converter (SRC)		-
Programmable input gain	analog: from -94 dB to +16 dB <sup>⊗</sup> digital: from -110 dB to +18 dB		-
Other inputs	AES/EBU Sync (up to 200 kHz), 2 GPI (dry contact), LTC		
AES11 synchronization	Yes		

\* enabling phantom power (48 V) may increase this value by 50%  
using the 10 V AES42 power to feed the microphone may increase this value by 90%

\*\* can be used with unbalanced signals

\*\*\* can be used as S/PDIF interface as well

⊗ maximum sensitivity: 0 dBFs for -16 dBu input

## Additional functionalities – PCX924e-Mic

Microphone input	1 professional mono with - high-quality preamplifier - switchable 48 V phantom power - analog expander/compressor/limiter <i>This input is mixed with the two line inputs before A/D conversion.</i>
Digital input (stereo)	The input AES/EBU IN* is AES42 compatible - supplying 10 V to feed a digital microphone - allowing remote microphone control.

## Outputs

	PCX924e	PCX924e-Mic	PCX22e
Analog line outputs (mono)	2 servo-balanced**		
Maximum output level / impedance	+24 dBu / < 100Ω		
Digital outputs (stereo)	1 AES/EBU, up to 200 kHz		
Programmable output gain	analog: from -24 dB to +24 dB digital: from -110 dB to +18 dB		
Other outputs	1 stereo headphone output (600 Ω) 2 GPO (relay, 0.5 A, 48 VCC)		

## Connectors

	PCX924e	PCX924e-Mic	PCX22e
Internal connector	inter-board synchronization		
External connectors	<ul style="list-style-type: none"> <li>• 15-pin Sub-D for analog I/Os</li> <li>• 15-pin HD Sub-D for digital I/Os, Sync., and GPIO</li> <li>• 1 mini jack headphone stereo output (3.5 mm TRS female jack)</li> </ul>		

\* can be used as S/PDIF interface as well

\*\* electronically servo-balanced outputs provide automatic level adjustment to accommodate either balanced or unbalanced lines



# PCX924e & PCX924e-Mic, PCX22e

## User's Manual

### Audio specifications

	PCX924e	PCX924e-Mic	PCX22e
Sampling frequencies available	Programmable from 8 to 192 kHz		
A/D and D/A converter resolution	24 bits		
Supported audio formats	PCM (8, 16, 24 bits), Float IEEE754, MPEG (Layer I, II, and III up to 48 kHz)		

### Analog audio performance

Measurements done at  $F_s=48$  kHz unless stated otherwise, with filter on the 22 Hz- 22 kHz range

	PCX924e	PCX924e-Mic	PCX22e
Frequency response (record + play)	at 48 kHz: 20 Hz - 20 kHz: +0 /-0.3 dB at 96 kHz: 20 Hz - 40 kHz: +0 /-0.4 dB at 192 kHz: 20 Hz - 80 kHz: +0 /-1.1 dB		
Channel phase difference: 20/20kHz	<0.2°/2°		
Dynamic range (A-weighted)	Analog In: >104 dB* Analog out: > 106 dB		
THD + noise 1 kHz at -2 dBfs	Analog In: >-97 dB* Analog out: <-95 dB		
Crosstalk (Analog in or out)	1 kHz at 24 dBu: <-115 dB 15 kHz at 24 dBu: <-100 dB		

\* PCX924e & PCX924e-Mic only

### Sample rate converter performance

	PCX924e	PCX924e-Mic
Maximum frequency	192 kHz	
Frequency ratio	from 1:8 to 7.5:1	
THD + noise 1 kHz at -2 dBfs	<-130 dB	

## Analog mono microphone input features - PC924e-Mic

Power supply	switchable 48 V phantom power
Programmable mic gain	0 to 66 dB in 0.5 dB steps
Maximum input level/impedance	+10 dBu / < 10kΩ
Equivalent Input Noise, A/D-D/A at 48kHz, G=60 dB	<-125 dBu
Programmable noise-gate threshold	-52 dB, -42 dB, -32 dB
Programmable compressor/limiter threshold	from -26 dB to 0 dB
Programmable compressor ratio	1, 1.2, 1.5, 1.8, 2, 2.5, 3, 3.5, 4, 4.5
Programmable compressor/limiter gain	from 0 to 16 dB
Limiter ratio	15:1
Compressor/limiter release time	150 ms
Management of line and mic inputs	Mixed together before A/D, with independent level and mute controls

## AES42 microphone input features - PCX924e-Mic

Power supply	10 V min / 250 mA max
Remote control	Yes
Supported synchronization	Operational mode 1 (the microphone generates its own clock)

## Development environments

	PCX924e	PCX924e-Mic	PCX22e
Digigram management	np SDK (PCM and MPEG)		
Other management	Wave* (PCM, MPEG), ASIO, and DirectSound (PCM)		
Supported operating systems	Windows XP**, Windows Server 2003**, and Windows Vista**		
Main on-board processing features (with np SDK)	PCM play & rec, MPEG Layers I & II play & rec, Layer III play, Float IEEE754, direct monitoring, real-time mixing, level adjustment, panning, cross-fade, punch-in/punch-out, scrubbing, time-stretching, pitch-shifting, 3-band parametric equalizer, maximizer, format and frequency conversions		

\* Windows XP and Server 2003 only; for Windows Vista, a Wave driver is available on request.

\*\* 32-bit version

# PCX924e & PCX924e-Mic, PCX22e

## User's Manual

### APPENDICES

#### PCX924e Schematic Diagram

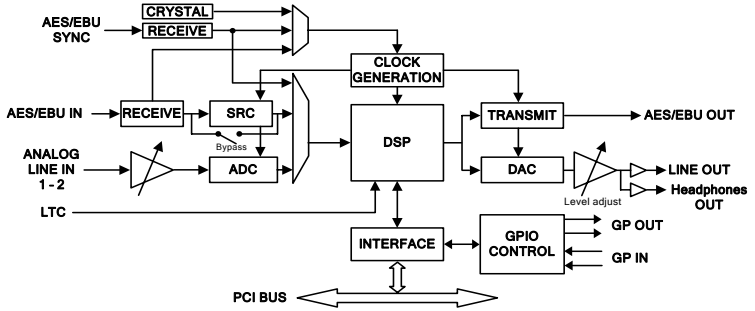

#### PCX924e-Mic Schematic Diagram

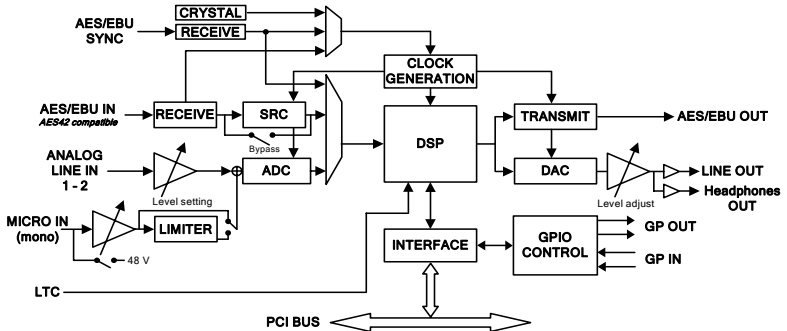

#### PCX22e Schematic Diagram

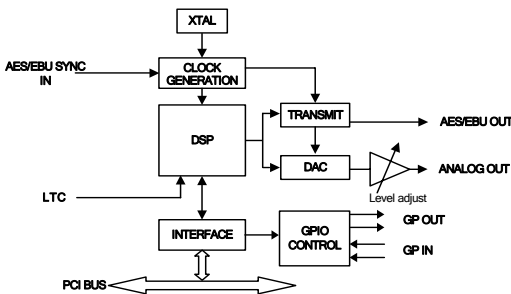

## PCX924e & PCX924-Mic layout

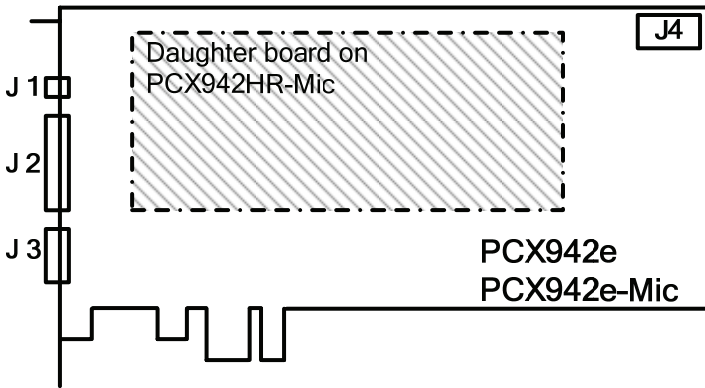

## PCX22e layout

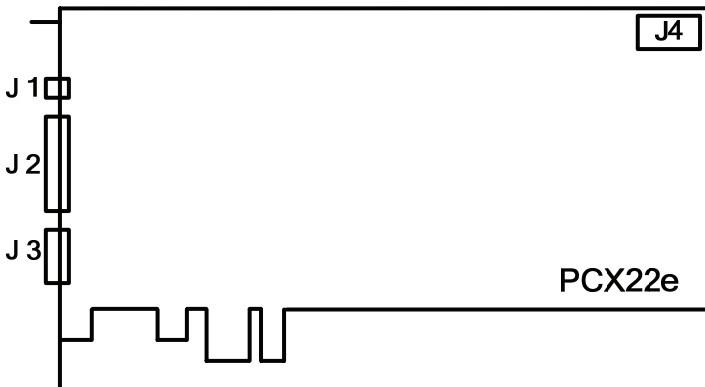

**J1: Headphone connector**  
(3.5 mm TRS female jack)

Contact	Signal
Sleeve	Ground
Tip	Left channel
Ring	Right channel

**J2: Analog cable**

**J3: Digital cable**

**J4: Inter-card synchronization connector**

# PCX924e & PCX924e-Mic, PCX22e

## User's Manual

### PCX924e - analog cable diagram:

Analog cable delivered by Digigram:

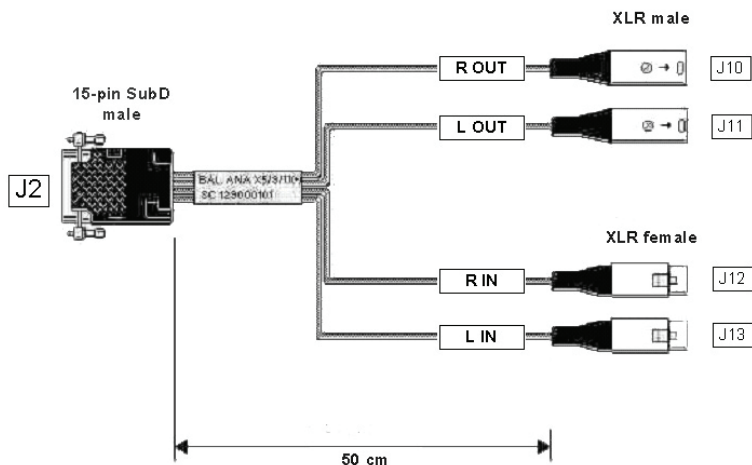

### PCX924e-Mic - analog cable diagram:

Analog cable delivered by Digigram:

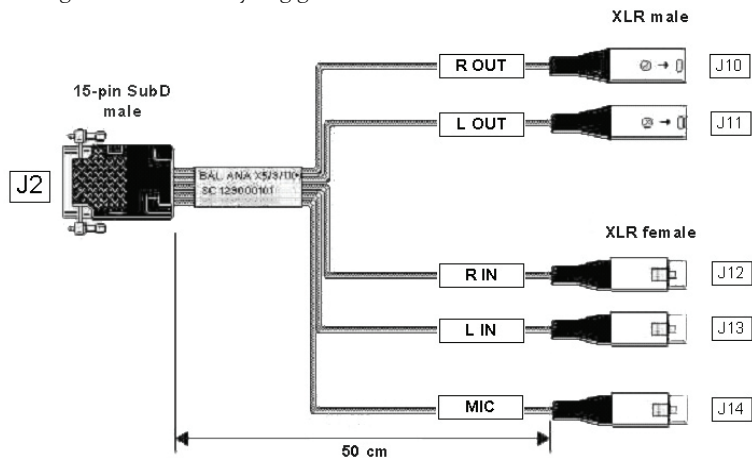

## PCX924e Wiring Diagram - analog cable

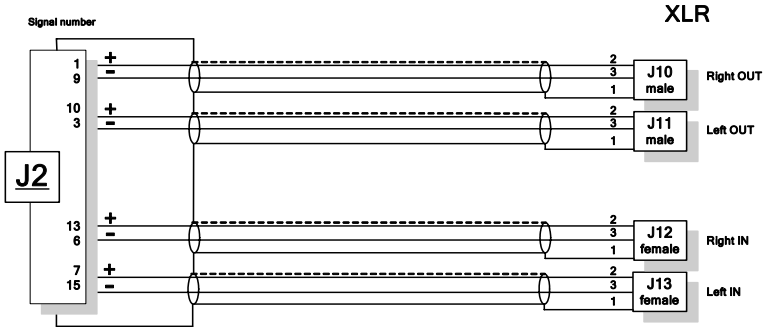

## PCX924e-Mic Wiring Diagram - analog cable

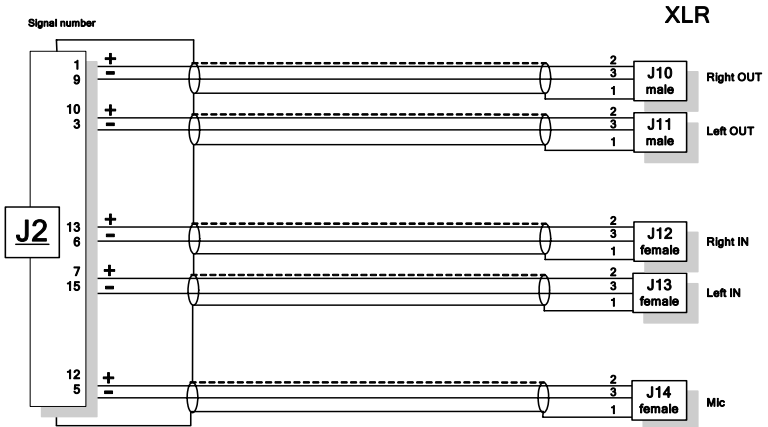

# PCX924e & PCX924e-Mic, PCX22e

## User's Manual

### PCX924e & PCX924e-Mic digital cable with GPIOs

Schematic diagram of the cable delivered by Digigram\*:

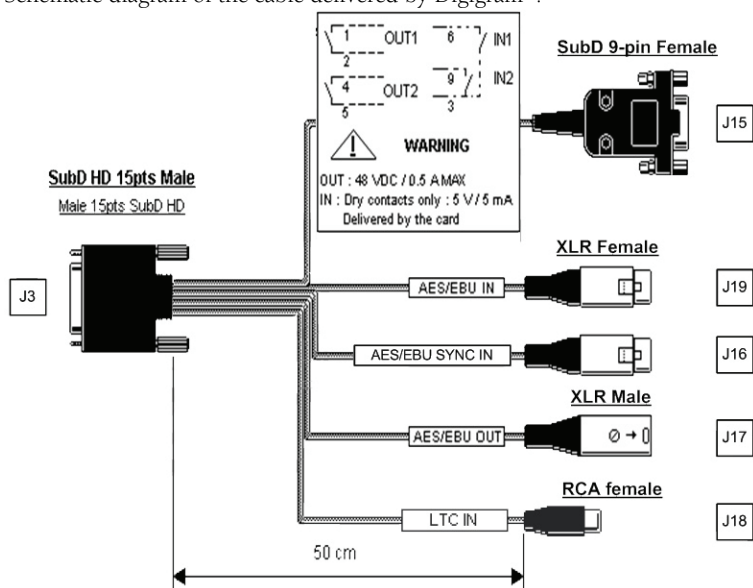

### PCX924e & PCX924-Mic digital cable without GPIOs

Schematic diagram of the cable delivered by Digigram\*:

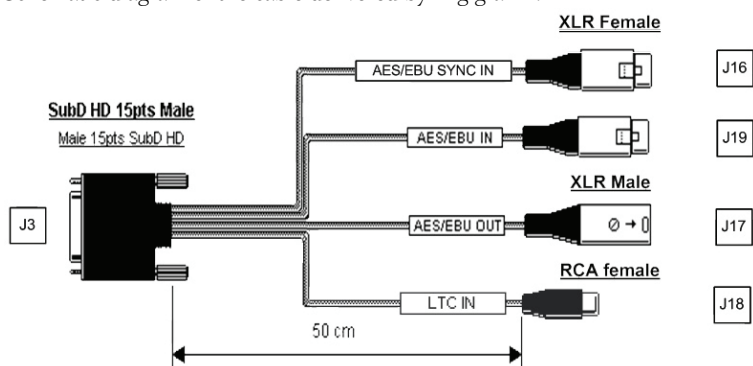

\* Your cable may look different if it is not a Digigram cable.





# PCX924e & PCX924e-Mic, PCX22e

## User's Manual

### PCX22e - analog cable diagram

Analog cable delivered by Digigram:

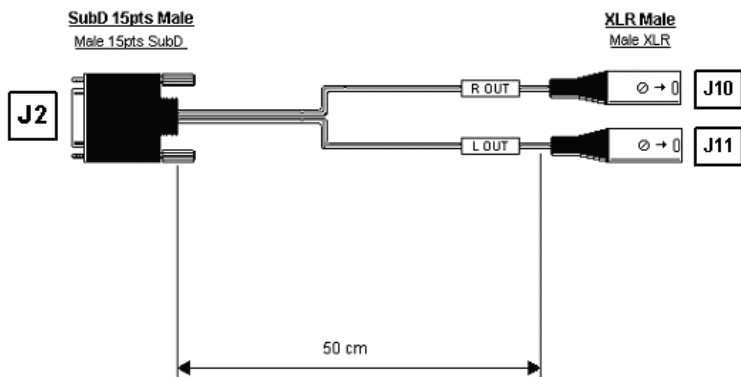

### PCX22e - Wiring Diagram - analog cable

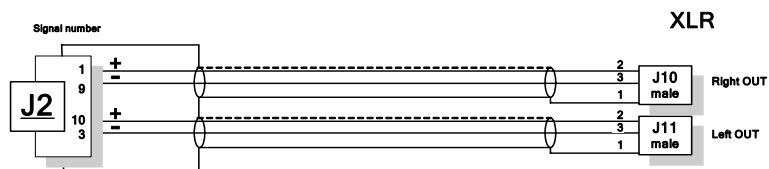

## PCX22e - digital cable with GPIOs

Schematic diagram of the cable delivered by Digigram\*:

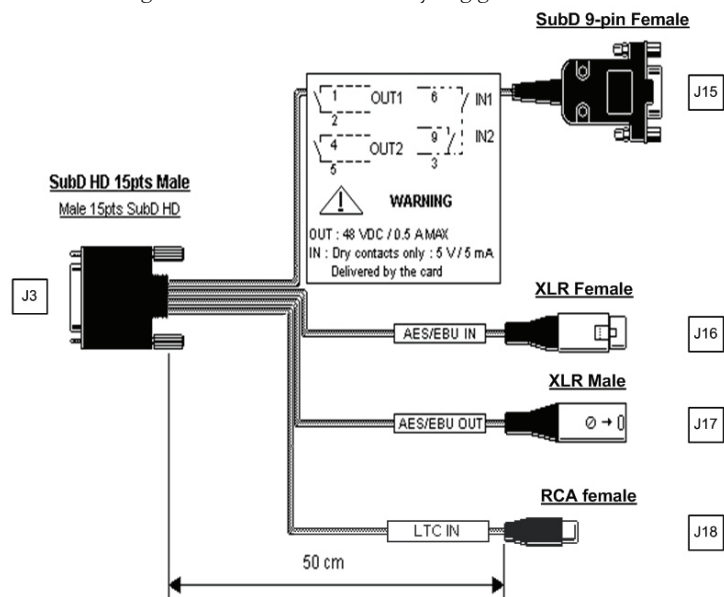

## PCX22e - digital cable without GPIOs

Schematic diagram of the cable delivered by Digigram\*:

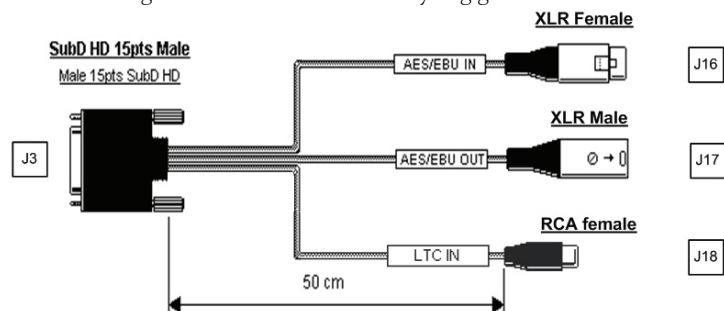

\* Your cable may look different if it is not a Digigram cable.

# PCX924e & PCX924e-Mic, PCX22e

## User's Manual

### PCX22e - Wiring Diagram - digital cable with GPIOs

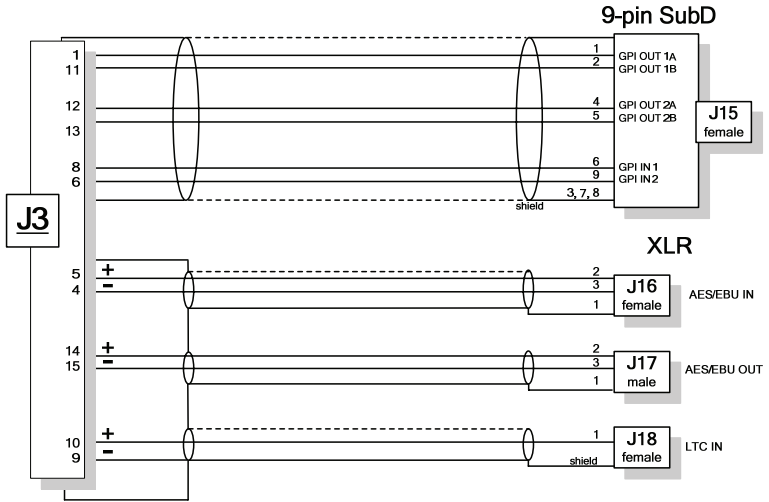

### PCX22e - Wiring Diagram – digital cable without GPIOs

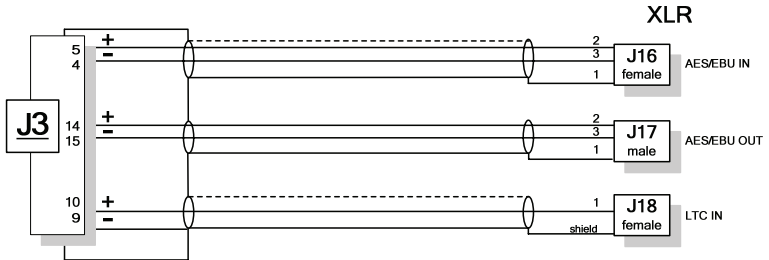

## PCX924e - cable pinout

Pin #	ANALOG	DIGITAL
1	R OUT +	GPIO OUT 1A
2	GND	AES/EBU IN -
3	L OUT -	AES/EBU IN +
4	GND	AES/EBU SYNC IN -
5	NC	AES/EBU SYNC IN +
6	R IN -	GPI INPUT 2
7	L IN +	GND/GPIO INPUT COMMON
8	GND	GPI INPUT 1
9	R OUT -	GND
10	L OUT +	LTC IN
11	GND	GPIO OUT 1B
12	NC	GPIO OUT 2A
13	R IN +	GPIO OUT 2B
14	GND	AES/EBU OUT +
15	L IN -	AES/EBU OUT -

## PCX924e-Mic - cable pinout

Pin #	ANALOG	DIGITAL
1	R OUT +	GPIO OUT 1A
2	GND	AES/EBU IN -
3	L OUT -	AES/EBU IN +
4	GND	AES/EBU SYNC IN -
5	MIC IN -	AES/EBU SYNC IN +
6	R IN -	GPIO INPUT 2
7	L IN +	GND/GPI INPUT COMMON
8	GND	GPI INPUT 1
9	R OUT -	GND
10	L OUT +	LTC IN
11	GND	GPI OUT 1B
12	MIC IN +	GPI OUT 2A
13	R IN +	GPI OUT 2B
14	GND	AES/EBU OUT +
15	L IN -	AES/EBU OUT -

# PCX924e & PCX924e-Mic, PCX22e

## *User's Manual*

### PCX22 v2 cable pinout

Pin #	ANALOG	DIGITAL
1	R OUT +	GPI OUT 1A
2	GND	NC
3	L OUT -	NC
4	GND	AES/EBU SYNC IN 1-
5	NC	AES/EBU SYNC IN 1+
6	NC	GPI INPUT 2
7	NC	GND/GPI INPUT COMMON
8	GND	GPI INPUT 1
9	R OUT -	GND
10	L OUT +	NC
11	GND	GPI OUT 1B
12	NC	GPI OUT 2A
13	NC	GPI OUT 2B
14	GND	AES/EBU OUT +
15	NC	AES/EBU OUT -

