

D i g i g r a m

UAX220v2

UAX220-Mic

*Professional USB Audio
Interface*



User's manual

**For technical support,
please contact your supplier**

www.digigram.com



Digigram S.A.

Parc de Pré Milliet, 38330 Montbonnot - FRANCE

Tel: +33 (0)4 76 52 55 01 • Fax: +33 (0) 4 76 52 53 07 • E-mail: info@digigram.com

Digigram Inc.

2101 Wilson Boulevard, Suite 1004, Arlington, VA 22201-USA

Tel: +1 703 875 9100 • Fax: +1 703 875 9161 • E-mail: input@digigram.com

Digigram Asia Pte Ltd.

350 Orchard Road - #19-07 Shaw House Singapore 238868-SINGAPORE

Tel: +65 6291 2234 • Fax: +65 6291 2234 • Fax: info_asia@digigram.com

UAX220v2 & UAX220-Mic

User's manual

Table of Contents

INFORMATION FOR THE USER	4
IMPORTANT NOTICE	4
CONTENTS OF THIS PACKAGE	5
FEATURES	5
Main hardware features.....	5
UAX220-Mic: Additional hardware features.....	6
Software features.....	6
HARDWARE REQUIREMENTS	6
Supported operating systems.....	6
HARDWARE INSTALLATION	6
SOFTWARE INSTALLATION	6
HOW TO CHECK THE INSTALLATION	7
Under Windows.....	7
Under Mac OS X.....	8
Under Linux.....	8
CONTROLS	9
Manual controls.....	9
Software controls.....	10
Control Panel under Windows.....	10
Mac OS volume Control Panel.....	12
CONFIGURATION	13
UAX Manager.....	13
Control Panel under Windows.....	13
Control Panel under Mac.....	14
SPECIFICATIONS	15
Configuration.....	15
Inputs.....	15
Outputs.....	16
Connectors.....	16
Audio specifications.....	16
Analog audio performance.....	17
Environments.....	17
APPENDICES	18
Schematic diagram UAX220 & UAX220-Mic.....	18
XLR-3 connector pinout.....	18
Headphone connector.....	18

Copyright 2006 Digigram. All rights reserved.

No portion of this manual may be reproduced without prior written consent from Digigram. The copyright protection claimed here includes photocopying, translation and/or reformatting of the information contained in this manual.

While every effort has been made to ensure accuracy, Digigram is not responsible for errors and omissions, and reserves the right to make improvements or changes in the products and programs described without notice.

Digigram and the Digigram logo, UAX220V2 and UAX220-Mic are registered trademarks or trademarks of Digigram S.A. All other trademarks are property of their respective holders.

DUI0400101 IS-01

INFORMATION FOR THE USER

This device complies with part 15 of FCC rules. Operation is subject to the following two conditions: (1) This device may not cause harmful interference, and (2) This device must accept any interference received, including interference that may cause undesired operation.

This equipment has been tested and found to comply with the limits for a CLASS B digital device, pursuant to Part 15 of the FCC Rules. These limits are designed to provide reasonable protection against harmful interference in a residential installation. This equipment generates, uses, and can radiate radio frequency energy and, if not installed and used in accordance with the instructions contained in this data sheet, may cause harmful interference to radio and television communications. However, there is no guarantee that interference will not occur in a particular installation.

If this equipment does cause harmful interference to radio or television reception, which can be determined by turning the equipment off and on, the user is encouraged to try to correct the interference by one or more of the following measures:

- * reorient or relocate the receiving antenna
- * increase the separation between the equipment and the receiver
- * connect the equipment into an outlet on a circuit different from that of the receiver
- * consult the dealer or an experienced audio television technician.

Note: *Connecting this device to peripheral devices that do not comply with CLASS B requirements or using an unshielded peripheral data cable could also result in harmful interference to radio or television reception. The user is cautioned that any changes or modifications not expressly approved by the party responsible for compliance could void the user's authority to operate this equipment. To ensure that the use of this product does not contribute to interference, it is necessary to use shielded I/O cables.*

IMPORTANT NOTICE

This device has been tested and found to comply with the following standards:

- International: CISPR22 Class B
- Europe: EMC 89/336/CEE (1992) specifications.
- United States: FCC Rules-Part 15-Class B (digital device).

UAX220v2 & UAX220-Mic

User's manual

CONTENTS OF THIS PACKAGE

Thank you for purchasing a Digigram UAX220v2 or UAX220-Mic USB audio device.

The UAX220v2/UAX220-Mic package consists of the following components:

- * a UAX220v2 or UAX220-Mic
- * the user's manual at hand.
- * a carrying case

Feel free to visit our web site www.digigram.com to get more technical information, consult FAQs, and discover our complete and updated audio product line.

FEATURES

UAX220v2/UAX220-Mic is a stereo audio interface for USB ports (compatible with USB ports 1.1 and 2.0). It is powered via USB, and does not require any driver installation (as it is compatible with the USB Audio specification 1.0).

Main hardware features

- 2 balanced analog mono line inputs*, with a maximum input signal of +22 dBu
- 2 balanced analog mono line outputs**, with a maximum output signal of +10 dBu
- Switchable -12 dB input signal level attenuator
- Switchable zero-latency direct monitoring of the inputs on the outputs via DSP

Note: *the input monitoring is mixed on the output with the sounds played by the application.*

- Possibility to switch the input monitoring to mono mode "left channel + right channel"
- Possibility to record both inputs mixed
- 1 stereo headphone output on female ¼ " jack with knob for gain adjustment
- A/D and D/A conversions up to 24 bits/48 kHz

* can be used with unbalanced signals

** electronically servo-balanced outputs provide automatic level adjustment to accommodate either balanced or unbalanced lines

UAX220-Mic: Additional hardware features

- 2 balanced* analog mono mic/line inputs
- 2 knobs for left and right input gain adjustment, from 0 dB to 50 dB
- Left and right 48 V phantom power switches for static microphones

Software features

UAX220v2 and UAX220-Mic comply with the USB Audio specification. Therefore, and depending on the operating system used, they are compatible with *WDM DirectSound*, *ALSA*, and *CoreAudio*. Furthermore, it is possible to use a third-party ASIO driver (*Asio4all*, *Ploytec*).

HARDWARE REQUIREMENTS

- A USB port (standard 1.1 or higher)
- Minimum Apple Macintosh configuration:
PowerMac G3, G4 or G5 with 128 MB RAM
- Minimum PC configuration:
Pentium III (or equivalent), 256 MB RAM.

Supported operating systems

Windows XP

Mac OS X

Linux

HARDWARE INSTALLATION

Connect the UAX220v2/UAX220-Mic to the USB port (USB 1.1 or 2.0) of your computer. It will then automatically be detected by the operating system and its driver will also be automatically installed.

Note: *If you have several USB peripherals connected to your computer, they may consume more energy than the USB port can provide. In this case, disconnect some of these peripherals.*

SOFTWARE INSTALLATION

Your UAX220v2/UAX220-Mic does not require any driver installation, because it meets the USB Audio 1.0 standard, which is supported by your operating system (Windows XP, Mac OS X, Linux).

* can be used with unbalanced signals

UAX220v2 & UAX220-Mic

User's manual

HOW TO CHECK THE INSTALLATION

Once the UAX220v2/UAX220-Mic is connected to the USB port of your computer, you can check the accessibility of its inputs/outputs as described hereafter.

Under Windows

Go to <Start>, <Settings>, <Control panel>, <Sounds and Audio Devices>, tab 'Hardware'. Select "USB Audio device" and click on "Properties".

The UAX will be displayed like this:

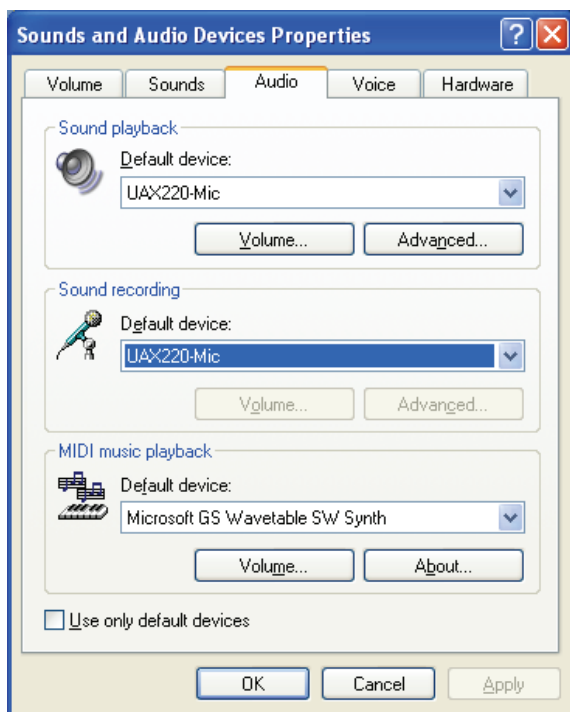

Under Mac OS X

Go to <System Preferences>, <Sound>. The UAX will be displayed as follows.

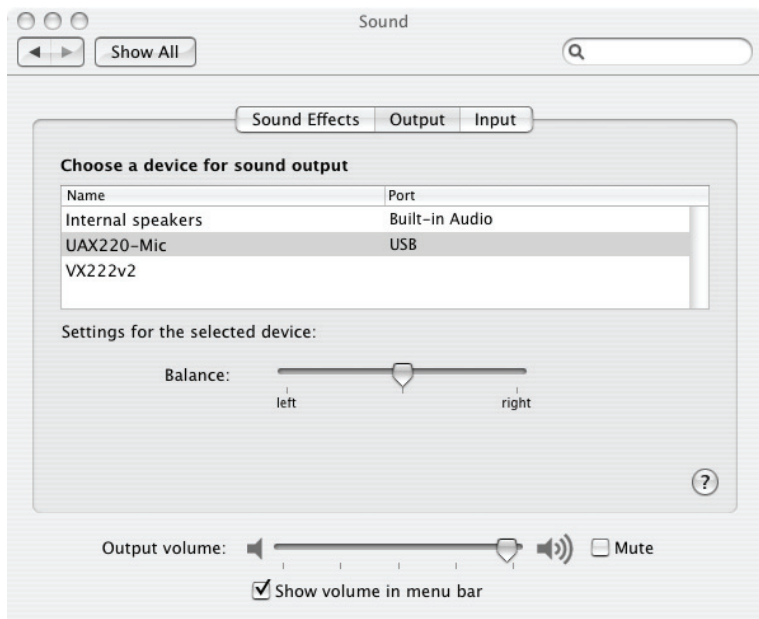

Under Linux

The parameters of the UAX220v2/UAX-Mic are accessible from the audio application of your choice.

CONTROLS

UAX220v2 and UAX220-Mic feature switches and faders for manual controls as well as adjustments via software.

Manual controls

- **48V (UAX220-Mic)**
These two switches (one per input channel) allow enabling/disabling the 48 V phantom power for condenser microphones. This power supply is activated on a channel when the corresponding LED is lit.
- **In1 and In2: (UAX220-Mic)**
These two knobs allow adjusting the analog gain on each input, from 0 dB to +50 dB. The “Peak” LEDs light up when the input level is too high.
- **Pad**
This switch permits to attenuate the analog input signal level by -12dB. The attenuation is active when the corresponding LED is lit.
- **1+2**
This switch allows adding up the left and right input channels. The summation is active when the corresponding LED is lit. The signal arising from the summation is then available on the left and right channels to be recorded, and/or to be sent to the outputs, if the monitoring is activated.
- **Monitoring ON**
This switch allows sending the input monitoring signal to the outputs (modified by the various input adjustments)
- **Monitoring Mono**
This switch allows monitoring on the summation of left and right channels on the outputs. The summation is active when the corresponding LED is lit.
Digital recording of the stream played
With “Monitoring Mono” activated and the “Monitoring On” disabled, the UAX allows to record the played stream without passing through the analog inputs/outputs. This makes it possible, for example, to record an Internet broadcast using an application such as *Windows Media Player*.
- **Headphones out level adjustment**
The knob marked with a headphones symbol allows adjusting the audio level on the headphones output. This setting does not affect the line outputs.

Software controls

Control Panel under Windows

To control the levels of your UAX220v2 or UAX220-Mic, use the Volume Control application. To open this application, double-click onto the loudspeaker icon in the Windows task bar. In case this icon is not displayed in the task bar, go to <Start>, <Settings>, <Control panel>, <Sounds and Multimedia >.

On the 'Volume' tab, check the box "Show volume icon in the task bar".

The UAX220v2/UAX220-Mic offers Volume and Mute controls for the outputs. These controls are not available for the inputs.

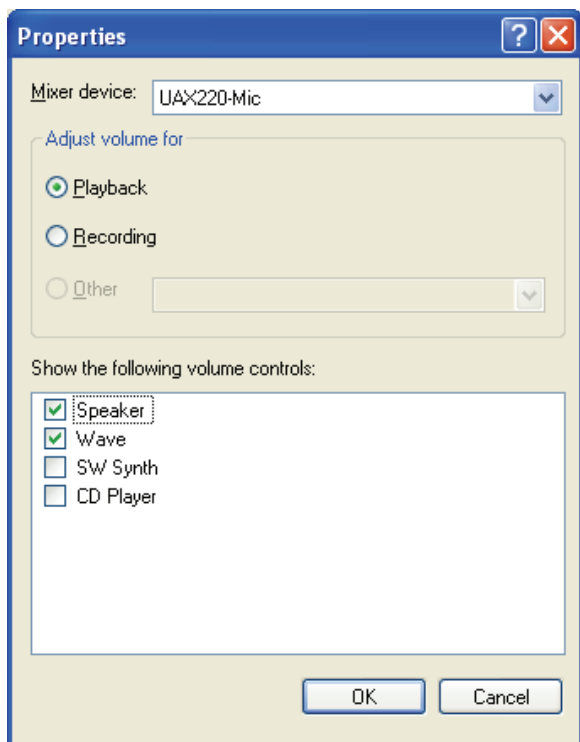

UAX220v2 & UAX220-Mic

User's manual

'Loudspeaker' volume control

The fader 'Loudspeaker' modifies the analog output gain of the UAX220v2/UAX220-Mic. The applied gain varies from -60 dB to +10 dB, by steps of 1 dB. These controls are applied to both line and headphones outputs.

The check box 'All mute' in the loudspeaker section allows muting/unmuting the outputs of your UAX220v2/UAX220-Mic.

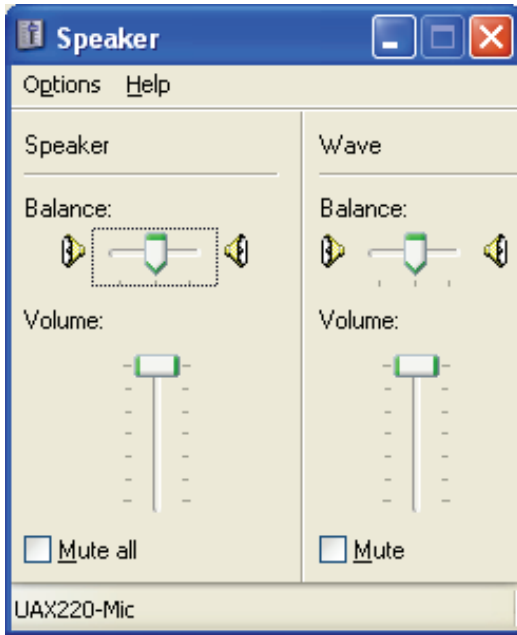

'Wave sounds' volume control

The volume and mute controls are applied to the audio stream read by the application. Therefore it is a digital gain adjustment.

Mac OS volume Control Panel

The fader 'Output volume' modifies the output level of the D/A converters of UAX220v2/UAX220-Mic.

The 'Mute' checkbox next to the volume control allows to mute/unmute the UAX220v2/UAX220-Mic outputs.

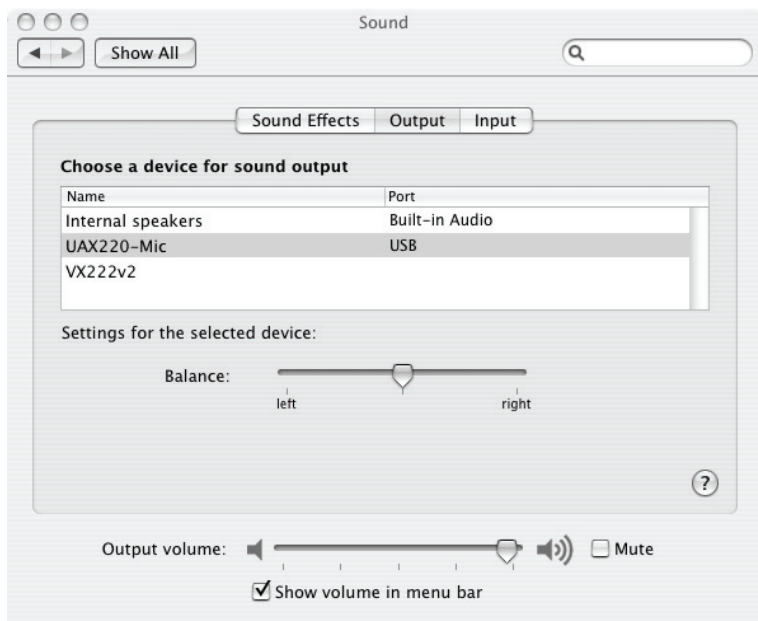

CONFIGURATION

UAX Manager

The UAX Manager application (available on the Digigram web site) allows UAX220v2/UAX220-Mic to

- either work at a fixed frequency (32 kHz, 44,1 kHz or 48 kHz), or at the frequency defined by the application
- to process the samples at 16 or 24 bits.

Default factory setting is: frequency fixed at 48 kHz, 24-bit sample resolution.

In the “sampling frequency set by audio application” mode, if the frequency of the application is other than 32 kHz, 44,1 kHz or 48 kHz, then the UAX works at 48 kHz and sample rate conversion is performed by the audio layers of the operating system.

In the “Frequency fixed” mode, sample rate conversion is performed by the audio layers of the operating system if the frequency of the application and the frequency of the UAX are different.

UAX Manager under Windows

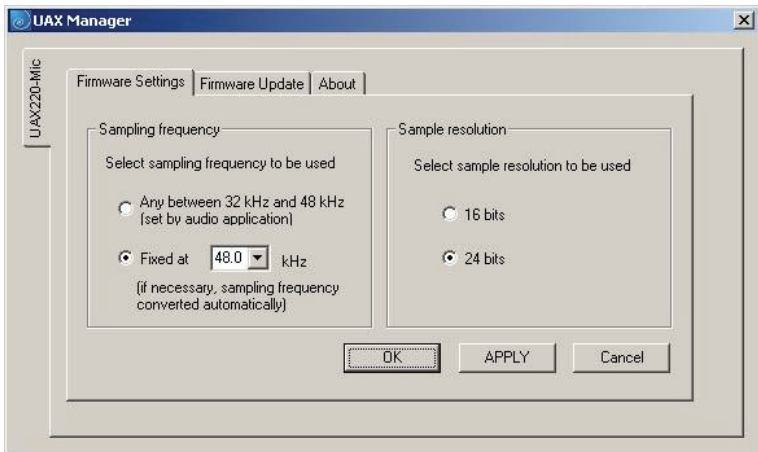

UAX Manager under Mac

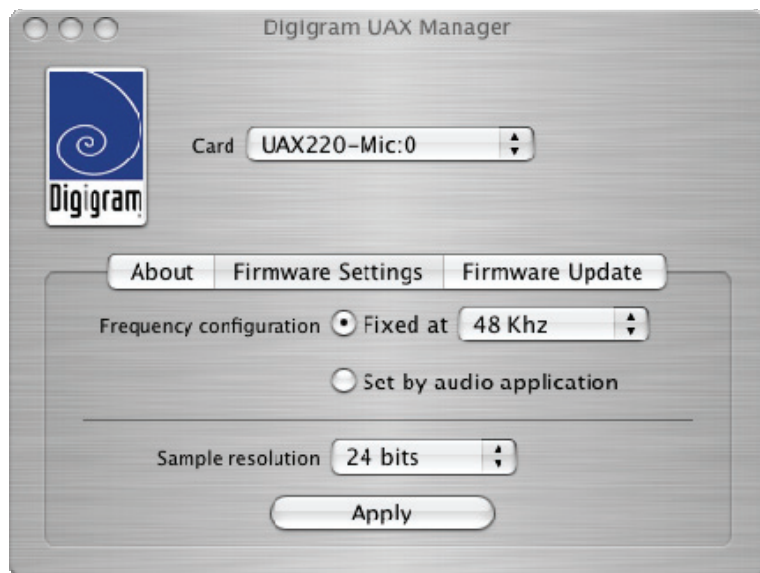

UAX220v2 & UAX220-Mic

User's manual

SPECIFICATIONS

CONFIGURATION

	UAX220v2	UAX220-Mic
Bus/Format	USB 1.1, compatible 2.0	
Size	144 mm X 87 mm X 34 mm Integrated USB cable: 1.5 m Integrated audio cable: 0.75 m	
Power consumption	500 mA max.	
Operating: temp / humidity (non-condensing)	0°C / +50°C • 5% / 90%	
Storage: temp / humidity (non-condensing)	-5°C / +70°C • 0% / 95%	

INPUTS

	UAX220v2	UAX220-Mic
Analog line inputs (mono)	2 balanced*	2 balanced** mic/line with: - professional high-quality preamps - switchable 48 V phantom power supply (mono)
Maximum input level/impedance	+22 dBu**/+10dBu/ >10 k Ω (switchable)	

* can be used with unbalanced signals

** limited to +15 dBu in unbalanced

OUTPUTS

	UAX220v2	UAX220-Mic
Analog line outputs (mono)	2 servo-balanced ^{***}	
Maximum output level / impedance	+10 dBu/<100 Ω	
Programmable output gain	by steps of 1 dB, from -60 dB to +10 dB ^{****}	
Other outputs	1 stereo headphones out with dedicated output stage and level adjustment knob (Maximum output power/minimum load: 2*40 mW / 32 Ω)	

CONNECTORS

	UAX220v2	UAX220-Mic
External connectors	<ul style="list-style-type: none"> • Standard USB type A for connection with computer • 2 Neutrik™ XLR-3 female for line inputs • 2 Neutrik™ XLR-3 male for line outputs • Locking ¼" Neutrik™ cable jack, female, for headphones output 	

AUDIO SPECIFICATION

	UAX220v2	UAX220-Mic
Sampling frequencies available	32 / 44.1 / 48 kHz	
A/D and D/A converter resolution	24 bits	
Supported audio formats	PCM (8, 16 et 24 bits, full-duplex)	
Operating modes	Either selected by application or user-selectable at a fixed resolution (modes selected via UAX Manager application)	
Monitoring	Zero latency direct monitoring through DSP Mixed with playback to line and headphone outputs	
Monitoring control	On/off and mono/stereo	

^{***} electronically servo-balanced outputs provide automatic level adjustment to accommodate either balanced or unbalanced lines

^{****} converter gain N/A, reference value : 0 dBfs equals 0 dBu

UAX220v2 & UAX220-Mic

User's manual

ANALOG AUDIO PERFORMANCE

Measurements done at $F_s=48$ kHz unless stated otherwise, with filter on the 22 Hz-22 kHz range

	UAX220v2	UAX220-Mic
Frequency response (record + play)	20 Hz - 20 kHz: ± 0.2 dB	
Channel phase difference: 20/20kHz	$< 0.2^\circ/2^\circ$	
Dynamic range (A-weighted)	Input: < -104 dB Output: > 104 dB	
THD + noise 1 kHz at -1 dBfs	Input: < -98 dB Output: < -97 dB Loop: < -93 dB	Input: < -97 dB Output: < -97 dB Loop: < -93 dB
Crosstalk (Analog in or out)	1 kHz at 22 dBu: < -110 dB 15 kHz at 22 dBu: < -95 dB	
Number of mic inputs		2 analog mono with switchable 48V phantom power supply
Programmable mic gain		0 à 50 dB by knob
48 V power supply	-	2*5 mA max
Equivalent Input Noise, A/D-D/A at 48kHz, $G=+50$ dB dB		< -125 dBu

ENVIRONMENTS

	UAX220v2	UAX220-Mic
Supported operating systems	Windows XP, Windows 2003 Server, Mac OS X, Linux	
Management	Depending on the host operating system's implementation of the USB Audio specification: DirectSound, Core Audio, ALSA	
Additional management	Digigram np SDK through Virtual PCX Third-party Asio driver	

APPENDICES

Schematic diagram UAX220v2 & UAX220-Mic

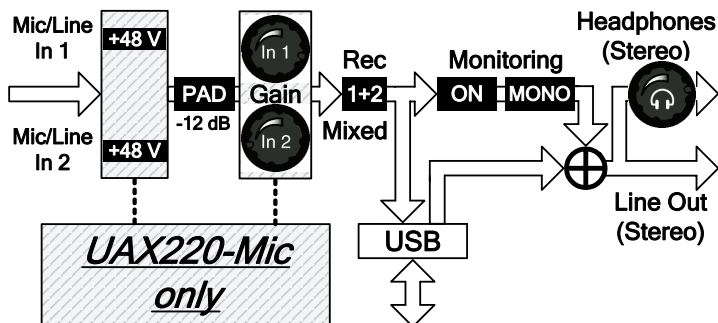

XLR-3 connector pinout

Pin #	Signal
1	Ground
2	Positive signal ('hot pin')
3	Negative signal ('cold pin')

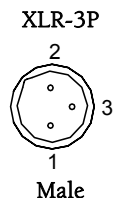
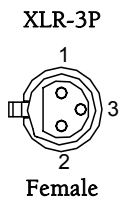

Headphone connector

Contact	Signal
Sleeve	Ground
Tip	Left channel
Ring	Right channel