



## Directional Drilling Guidance System

# Operator's Manual

403-2400-21-A metric, printed on 5/23/2016

© 2016 by Digital Control Incorporated. All rights reserved.

#### **Trademarks**

The Aurora logo, the DCI logo, Aurora<sup>®</sup>, DigiTrak<sup>®</sup>, DigiTrak Falcon<sup>®</sup>, F5<sup>®</sup>, and *Target Steering*<sup>®</sup> are U.S. registered trademarks and *Ball-in-the-Box*<sup>™</sup>, F Series<sup>™</sup>, and SuperCell<sup>™</sup> are common law trademarks of Digital Control Incorporated.

#### **Patents**

U.S. and foreign patents apply to the product covered by this manual. For details, please visit [www.DigiTrak.com/patents](http://www.DigiTrak.com/patents).

#### **Limited Warranty**

All products manufactured and sold by Digital Control Incorporated (DCI) are subject to the terms of a Limited Warranty. A copy of the Limited Warranty is included at the end of this manual; it can also be obtained at [www.DigiTrak.com](http://www.DigiTrak.com).

#### **Important Notice**

All statements, technical information, and recommendations related to DCI products are based on information believed to be reliable. However, DCI does not warrant or guarantee the accuracy or completeness of such information. Before using any DCI product, the user should determine the suitability of the product for its intended use. All statements herein refer to DCI products as delivered by DCI for use with horizontal directional drilling in the ordinary course, and do not apply to any user customizations, third-party products, or any usage of the DCI product outside of the ordinary course. Nothing herein shall constitute a warranty by DCI nor will anything herein be deemed to modify the terms of DCI's existing Limited Warranty applicable to all DCI products. DCI may update or correct the information in this manual from time to time. You may find the most recent version of this manual on DCI's website, [www.DigiTrak.com](http://www.DigiTrak.com). Under **Service & Support**, click **Documentation** and select from the **Manuals** drop-down menu.

#### **Compliance Statement**

This equipment complies with Part 15 of the Rules of the FCC and with Industry Canada license-exempt RSS standards and with Australia Class License 2000 for LIPD (low interference potential devices). Operation is subject to the following two conditions: (1) this equipment may not cause harmful interference, and (2) this equipment must accept any interference received, including interference that may cause undesired operation. DCI is responsible for FCC compliance in the United States: Digital Control Incorporated, 19625 62nd Ave S, Suite B103, Kent WA 98032; phone 425.251.0559 or 800.288.3610 (US/CA).

Changes or modifications to any DCI equipment not expressly approved and carried out by DCI will void the user's Limited Warranty and the FCC's authorization to operate the equipment.

#### **CE Requirements**



DigiTrak receivers are classified as Class 2 radio equipment per the R&TTE Directive and may not be legal to operate or require a user license to operate in some countries. The list of restrictions and the required declarations of conformity are available on DCI's website at [www.DigiTrak.com](http://www.DigiTrak.com). Under **Service & Support**, click **Documentation** and select from the **CE Documents** drop-down menu.

## Contact Us

---

**United States**  
*DCI Headquarters*  
19625 62nd Ave S, Suite B103  
Kent, Washington 98032, USA  
1.425.251.0559 / 1.800.288.3610  
1.425.251.0702 fax  
[dci@digital-control.com](mailto:dci@digital-control.com)

---

**Australia**  
2/9 Frinton Street  
Southport QLD 4215  
61.7.5531.4283  
61.7.5531.2617 fax  
[dci.australia@digital-control.com](mailto:dci.australia@digital-control.com)

---

**China**  
368 Xingle Road  
Huacao Town  
Minhang District  
Shanghai 201107, P.R.C.  
86.21.6432.5186  
86.21.6432.5187 fax  
[dci.china@digital-control.com](mailto:dci.china@digital-control.com)

---

**Europe**  
Brueckenstraße 2  
97828 Marktheidenfeld  
Germany  
49.9391.810.6100  
49.9391.810.6109 fax  
[dci.europe@digital-control.com](mailto:dci.europe@digital-control.com)

---

**India**  
DTJ 1023, 10th Floor  
DLF Tower A, DA District Center  
Jasola, New Delhi 110044  
91.11.4507.0444  
91.11.4507.0440 fax  
[dci.india@digital-control.com](mailto:dci.india@digital-control.com)

---

**Russia**  
Molodogvardeyskaya Street, 4  
Building 1, Office 5  
Moscow, Russia 121467  
7.499.281.8177  
7.499.281.8166 fax  
[dci.russia@digital-control.com](mailto:dci.russia@digital-control.com)

## Dear Customer,

---

Thank you for choosing a DigiTrak guidance system. We are proud of the equipment we have been designing and building in Washington State since 1990. We believe in providing a unique, high-quality product and standing behind it with world-class customer service and training.

Please take the time to read this entire manual, especially the section on safety. Please also register your equipment online at [access.DigiTrak.com](https://access.DigiTrak.com). Or, fill in the product registration card provided with this equipment and either fax it to us at 253-395-2800 or mail it to DCI headquarters.

Product registration entitles you to free telephone support (in the USA and Canada), notification of product updates, and helps us provide you with future product upgrade information.

Our Customer Service department is available 24 hours a day, 7 days a week in the U.S. to help with problems or questions. International contact information is available in this document and on our website.

As the horizontal directional drilling industry grows, we're keeping our eye on the future to develop equipment that makes your job faster, easier, and safer. Visit us online any time to see what we're up to.

We welcome your questions, comments, and ideas.

Digital Control Incorporated  
Kent, Washington  
2016

**Watch our DigiTrak Training Videos at [www.youtube.com/dcikent](https://www.youtube.com/dcikent)**

For system component name and model information, refer to [Appendix A: System Specifications](#) on page 65.

# Table of Contents

---

<b>Important Safety Instructions</b> .....	<b>1</b>
General .....	1
Pre-Drilling Testing .....	2
Interference .....	2
Potential Interference Received .....	2
Potential Interference Generated .....	2
Battery Pack Storage .....	3
Equipment Maintenance .....	3
General Transmitter Care Instructions .....	3
<b>Getting Started</b> .....	<b>5</b>
Introduction .....	5
Using This Manual .....	6
Powering On .....	6
Receiver .....	7
Transmitter .....	7
Remote Display (Aurora) .....	7
Setup Summary .....	7
Run Frequency Optimizer .....	7
Assign Frequency Bands .....	8
Interference Check .....	8
Calibrate .....	8
Above Ground Range Check .....	9
Drill .....	9
<b>Receiver</b> .....	<b>10</b>
Overview .....	10
Toggle and Trigger Switches .....	10
Audible Tones .....	11
Startup Screen .....	11
Using the Keypad .....	12
Your Remote Display .....	12
<b>Receiver Menus</b> .....	<b>13</b>
Locate Mode .....	14
Power Off .....	14
Calibration and AGR .....	14
1-Point Calibration .....	15
In-Ground Calibration .....	16
View Calibration .....	17
Above Ground Range (AGR) .....	17
15 m Calibration (Optional) .....	18
Height-Above-Ground (HAG) .....	18
Turn HAG On .....	19
Settings .....	20
Depth Units Menu .....	20

Pitch Units Menu .....	20
Set Time and Calendar Menu .....	21
Telemetry Channel Menu .....	21
Roll Offset Menu .....	22
Pressure Units Menu .....	23
Temperature Units Menu .....	23
Language Selection Menu .....	23
<b>Frequency Optimization and Transmitter Selection .....</b>	<b>24</b>
Frequency Optimization .....	24
So I Just Paired, Now What? .....	27
Transmitter Selection .....	27
View Frequency Optimization .....	28
Transmitter Information .....	28
<b>DataLog .....</b>	<b>29</b>
Left/Right Offset .....	30
Deviation .....	30
Flags and Pins .....	31
<b>Diagnostics .....</b>	<b>31</b>
Perform Level Check .....	32
Perform System Self-Test .....	32
Perform Signal Self-Test .....	33
<b>System Info .....</b>	<b>34</b>
<b>Locating Basics .....</b>	<b>35</b>
<b>Locating Screens .....</b>	<b>36</b>
Locate Screen .....	36
Locate Screen Shortcuts .....	37
Depth Screen .....	37
Predicted Depth Screen .....	38
Depth Screen, Invalid Location .....	39
<b>Interference .....</b>	<b>39</b>
What is Interference? .....	40
Checking for Interference .....	40
Roll/Pitch Check .....	41
Suggestions for Dealing with Interference .....	42
<b>Locate Points (FLP &amp; RLP) and Locate Line (LL) .....</b>	<b>43</b>
Effects of Depth, Pitch, and Topography on Distance Between FLP and RLP .....	44
Marking Locate Points .....	45
<b>Locating the Transmitter .....</b>	<b>45</b>
Finding the Front Locate Point (FLP) .....	46
Finding the Locate Line (LL) .....	47
Finding the RLP to Confirm Transmitter Heading and Position .....	49
<b>Advanced Locating .....</b>	<b>51</b>
Tracking “On-the-Fly” .....	51
Off-Track Locating .....	52
Target Steering .....	54
Feasible Target Steering Area .....	55
Turning Target Steering On .....	55
Positioning the Receiver as the Target .....	56

Steering to the Target with the Remote Display .....	57
Target Steering in Interference Areas .....	57
Turn Target Steering Off .....	57
<b>Transmitter .....</b>	<b>58</b>
Batteries and Power On/Off .....	58
Installing Batteries / Power On .....	59
Transmitter Battery Strength .....	60
Sleep Mode .....	60
Transmitter Drill Head Requirements .....	61
Temperature Status and Overheat Indicator .....	61
Transmitter Temperature Warning Tones .....	62
Transmitter Overheat Indicator (Temp Dot) .....	62
Changing Frequency Bands .....	63
Above Ground (Pre-Bore) Tilt Method .....	63
Below Ground (Mid-Bore) Roll Methods .....	63
<b>Appendix A: System Specifications .....</b>	<b>65</b>
Power Requirements .....	65
Environmental Requirements .....	65
Storage and Shipping Requirements .....	65
Temperature .....	65
Packaging .....	65
Equipment and Battery Disposal .....	66
Transmitter Pitch Resolution .....	66
<b>Appendix B: Receiver Screen Symbols .....</b>	<b>67</b>
<b>Appendix C: Projected Depth Versus Actual Depth and the Fore/Aft Offset .....</b>	<b>69</b>
<b>Appendix D: Calculating Depth Based on Distance Between FLP and RLP .....</b>	<b>73</b>
<b>Appendix E: Reference Tables .....</b>	<b>74</b>
Depth Increase in cm per 3-m Rod .....	74
Depth Increase in cm per 4.6-m Rod .....	75
<b>LIMITED WARRANTY</b>	





# Important Safety Instructions

## General

The following warnings relate generally to the operation of DigiTrak® guidance systems. This is not an exhaustive list. Always operate your DigiTrak guidance system in accordance with the manual and be aware of interference that may affect efforts to retrieve accurate data with this guidance system. Failure to do so can be hazardous. If you have any questions about the operation of the system, please contact DCI Customer Service for assistance.



To prevent potentially dangerous conditions, all operators must read and understand the following safety precautions, warnings, and instructions before using the DigiTrak Guidance System.



DigiTrak guidance systems cannot be used to locate utilities.

Failure to use the front and rear locate points technique described in this manual for locating the transmitter can lead to inaccurate locates.

Serious injury and death as well as substantial property damage can result if underground drilling equipment makes contact with an underground utility, including natural gas lines, high-voltage electrical cable, or other utilities.



DCI equipment is not explosion-proof and should never be used near flammable or explosive substances.

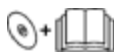

Work slowdowns and cost overruns can occur if drilling operators do not use the drilling or locating equipment correctly to obtain proper performance.

Directional drilling operators MUST at all times:

- Understand the safe and proper operation of drilling and locating equipment, including proper grounding procedures and techniques for identifying and mitigating interference.
- Ensure all underground utilities and all potential sources of interference have been located, exposed, and accurately marked prior to drilling.
- Wear protective safety clothing such as dielectric boots, gloves, hard hats, high-visibility vests, and safety glasses.
- Locate and track the transmitter in the drill head accurately and correctly during drilling.
- Maintain a minimum distance of 20 cm from the front of the receiver to the user's torso to ensure compliance with RF exposure requirements.
- Comply with federal, state, and local governmental regulations (such as OSHA).
- Follow all other safety procedures.

Remove the batteries from all system components during shipping and prolonged storage. Failure to do so may result in battery leakage, which may lead to risk of explosion, health risks, and/or damage.

Store and transport batteries using a suitable protective case that will keep batteries safely isolated from one another. Failure to do so may result in short circuits, which may lead to hazardous conditions including fire. See [Appendix A](#) for important restrictions on shipping lithium-ion batteries.

Use of this equipment is restricted to internal use at a construction site.

## Pre-Drilling Testing

Before each drilling run, test your DigiTrak guidance system with the transmitter inside the drill head to confirm it is operating properly and providing accurate drill head location and heading information.

During drilling, the depth will not be accurate unless:

- The receiver has been properly calibrated and the calibration has been checked for accuracy so the receiver shows the correct depth.
- The transmitter has been located correctly and accurately and the receiver is directly above the transmitter in the drill head underground or at the front locate point.
- The receiver is placed on the ground or held at the correct height-above-ground distance, which has been set correctly.

Always test calibration after you have stopped drilling for any length of time.

## Interference

The Falcon Frequency Optimizer selects frequencies based on measured active interference at a given point in time and space. Active interference levels can change with time and location, passive interference (which the system does not detect) may be present, and performance may vary as a result. Selections by the frequency optimizer are not a substitute for prudent operator judgment. If performance drops while drilling, consider switching to the other selected band or using Max mode.

### Potential Interference Received

Interference can cause inaccuracies in the measurement of depth and loss of the transmitter's pitch, roll, or heading. Always perform a background noise check using your receiver (locator), as well as a visual inspection for possible sources of interference, prior to drilling.

A background noise check will not identify all sources of interference, as it can only pick up sources that are active, not passive. Interference, as well as a partial list of sources of interference, are discussed in the section [Interference](#) on page 39.

Never rely on data that does not display quickly and/or remain stable.

If an **A** displays at the top right of the roll indicator or frequency optimizer at distances greater than 3.0 m from the transmitter, [attenuation](#) is in effect, indicating the presence of excessive noise that can lead to inaccurate depth readings.

### Potential Interference Generated

Because this equipment may generate, use, and radiate radio frequency energy, there is no guarantee that interference will not occur at a particular location. If this equipment does interfere with radio or television reception, which can be determined by powering the equipment off and on, try to correct the interference using one or more of the following measures:

- Reorient or relocate the receiving antenna.
- Increase the separation between the receiver and affected equipment.
- Consult the dealer, DCI, or an experienced radio/TV technician for help.
- Connect the equipment to an outlet on a different circuit.

## Battery Pack Storage

If you plan to store the battery packs for any period of time, please follow these guidelines:

- Do not store the battery pack at temperatures greater than 45° C.
- Do not store the battery pack in a fully discharged state.
- Do not store the battery pack in the battery charger.
- Do not store multiple batteries together where their terminals or other loose conductive materials may contact one another and cause a short circuit.

If a lithium-ion battery pack will be stored for an extended period of time, pre-charge the battery to a charge level of 30% to 50% (two or three LEDs illuminated on the meter). Do not store the battery pack for more than one year unless it is periodically recharged to the 30% to 50% level.

## Equipment Maintenance

Turn off all equipment when not in use.

Store the equipment in cases, away from extremes of heat, cold, and moisture. Test to confirm proper operation prior to use.

Clean the glass screens on the receiver and remote display only with a cleaner specifically formulated to not harm the protective coatings on the glass. If in doubt, use only warm water and a microfiber cloth. Do not use household or commercial window cleaning products that include chemicals such as ammonia, alcohol, or any acidic liquid; these cleaners can contain microscopic abrasive granules that will damage the anti-reflective coating and may cause the display to spot.

Clean equipment cases and housings using only a soft moist cloth and mild detergent.

Do not steam clean or pressure wash.

Inspect the equipment daily and contact DCI if you see any damage or problems. Do not disassemble or attempt to repair the equipment.

Do not store or ship this equipment with batteries inside. Always remove the batteries from the equipment before shipping or periods of non-use.

The battery charger provided with your DigiTrak guidance system is designed with adequate safeguards to protect you from shock and other hazards when used as specified within this document. If you use the battery charger in a manner not specified by this document, the protection provided may be impaired. Do not attempt to disassemble the battery charger, it contains no user-serviceable parts. The battery charger shall not be installed into caravans, recreational vehicles, or similar vehicles.

## General Transmitter Care Instructions

Periodically clean the spring and threads inside the battery compartment as well as the spring and threads of the battery end cap to ensure a proper power connection with the batteries. Use an emery cloth or wire brush to remove any oxidation that has built up. Be careful not to damage the battery cap O-ring; remove it while cleaning if necessary. After cleaning, use a conductive lubricant on the battery cap threads to keep it from binding in the battery compartment.



For better battery performance, all DCI battery-powered transmitters ship with both a special battery contact spring and a nickel-based anti-seize lubricant on the battery end cap to aid in electrical contact.



Before use, inspect the battery cap O-ring for damage that may allow water to enter the battery compartment. Replace the O-ring if the one installed becomes damaged.

Do not use chemicals to clean the transmitter.

Placing tape around the fiberglass tube of the transmitter, if space allows, will keep the fiberglass protected from most corrosive and abrasive environmental wear. Do not tape over the IR window as this will interfere with IR communication.

Falcon transmitters have a threaded hole (1/4"-20 thread) in the battery cap to allow the use of an insertion/extraction tool for installing and removing the transmitters in end-load housings. Ensure this hole remains clear of debris.

Send in the Product Registration Card or register online at [access.DigiTrak.com](https://access.DigiTrak.com) for the 90-day Limited Warranty.

# Getting Started

## Introduction



### DigiTrak Falcon F5 Guidance System with Aurora® Remote Display

Congratulations on your purchase of the DigiTrak Falcon F5® locating system. The Falcon wideband technology represents an important advancement in the detection of active interference at the jobsite. Falcon extends the performance range of the F5 receiver with a durable system that can be programmed to address the variability in jobsite interference.

Historically, walkover guidance systems have used a single frequency to transmit the underground signal to the receiver above ground. DCI pioneered this method with its earliest locating systems to deliver roll and pitch readings to the operator. As trenchless techniques have advanced, sources of active interference have increased at jobsites and interference has emerged as one of the primary obstacles to completing HDD installations on time.

One of the unique attributes of interference is that it varies from jobsite to jobsite. A single frequency that works well at one site may not be useable at another. Using a single frequency to carry the locating signal limits the operator's efficiency in areas with high interference and can delay the completion of the job.

The Falcon approach uses a simple procedure of walking the jobsite to measure noise and then optimizing the band of frequencies that will be most effective. The Falcon F5 wideband transmitter can be programmed with two optimized bands for maximum productivity around high interference. The optimizing process is easy and takes only minutes to perform at the beginning of each pilot bore. A Falcon system with a wideband transmitter substantially outperforms other locating systems in its class and enables more efficient installations.

The Falcon system comes standard with a receiver, remote display, batteries, and battery charger. The separate operator's manuals for these devices are located on the flash drive that accompanied your guidance system and also at [www.DigiTrak.com](http://www.DigiTrak.com).

## Using This Manual

This manual is an important tool for you as the operator of a Falcon guidance system. You can find it on the flash drive that accompanied your system or at [www.DigiTrak.com](http://www.DigiTrak.com). We encourage you to load it onto your mobile device and keep it handy so the information you need is always close at hand.



When something is worth a little extra attention, we'll mark it with this handy Notebook icon.



### What if I have a question about this topic?

As you read this manual, you may have questions. We've already answered some of them right at the source in boxes like this. If the topic isn't for you, skip it and read on.



### You might need this.

Sometimes it's handy to have some extra information at your fingertips. While it may be discussed in detail elsewhere in the manual, we've extracted and placed some important data right where you need it, with a page link if you want to read more.



### Go watch some TV.

Subjects with training videos available online will be marked with this icon.

To help find those distant details, the manual includes hyperlinks that will take you right there, like this example:

Prior to use, the receiver must be paired to and calibrated with the transmitter.

[Calibration and AGR](#)

*Page 14*

## Powering On





The regional designation number in the globes on the receiver startup screen and transmitter body must match. If they don't, contact your DigiTrak dealer.



### Toggle, trigger, go. *Page 10*

At the Locate screen, toggle down to open the Main menu. Toggle in any direction to reach the icon you want. Click the trigger to make a selection. In some cases, hold the trigger for additional information, such as a depth reading at the Locate screen.

## Receiver

1. Install a fully charged battery pack.
2. Power on the receiver by holding the trigger briefly.
3. Click to accept the “Read the manual before using” statement.
4. First time use: from the **Main > Settings** menu , set the depth units, pitch units, and telemetry channel.
5. On the Main menu, set the optional Height-Above-Ground .

[Settings](#)

Page 20

[Height-Above-Ground \(HAG\)](#)

Page 18

## Transmitter

Do not power on the transmitter until after running the frequency optimizer (see next section). After that, or after resuming work (such as after lunch) using the same frequency bands, simply install batteries with the positive end first and completely fasten the battery cap.





[Batteries and Power](#)

[On/Off](#)

Page 58

## Remote Display (Aurora)

The Aurora<sup>®</sup> remote display powers on automatically with the drill rig.

1. Connect the telemetry antenna and connect the Aurora to 10–28 VDC power on the drill rig. It displays the Home screen.
2. Tap **Main Menu** , then **Receiver**  to set your type of receiver, telemetry channel to match that of the receiver, and region.
3. Tap  to return to the Main Menu, then in the Settings tab, tap **Device**  to set the date, time, and depth and pitch units. Use the same settings as on the receiver. It is also good practice to use the same system of units (English or metric) on both devices.
4. Tap **Home**  to return to the Home screen. If the receiver is receiving data from a transmitter, that data will now display on the Aurora.

If you are using an existing DigiTrak remote display, select F5 to receive data from the locator, and refer to the separate operator's manual located on the flash drive that accompanied your guidance system and also at [www.DigiTrak.com](http://www.DigiTrak.com).

## Setup Summary

Getting started with a Falcon F5 receiver is easy: run the frequency optimizer, walk and scan the bore path, pair the receiver with the transmitter, calibrate, check Above Ground Range, and check for active interference. It's all summarized in the following several paragraphs, with links to the details later in this manual. If you're hungry for the details now, skip to [Receiver](#) on page 10.

## Run Frequency Optimizer

1. With the transmitter off (batteries not installed), take the receiver to the point along the intended bore that might create the biggest locating challenge, like the deepest point of the bore or where there is obvious active interference such as a railway crossing, transformer, traffic lights, or power lines.

2. Power on the receiver and from the Main menu select **Transmitter Selection**, then **Frequency Optimizer (FO)**.





[Frequency Optimizer](#)

Page 24

3. With the FO results active, walk the entire intended bore path with the receiver and note areas of high background noise (active interference). The higher a frequency band's bar is on the graph, the greater the interference. Note which band remains consistently low, since the band with the lowest level of interference will likely be the one you want to use.

## Assign Frequency Bands

1. On the receiver, click to move the selector on the bottom of the frequency optimizer graph to the band you want to use and hold briefly to select.
2. Assign as the Up or Down band.
3. Optional: select and assign a second frequency band.
4. Select **Pair** .
5. Insert batteries in the transmitter, positive end first, install the battery cap, and allow several seconds for the transmitter to fully power on and begin sending data to the receiver.
6. Align the receiver and transmitter IR windows within four cm of each other. Select  to open the pairing menu, then  again to pair.



### Are high frequency bands better than low frequency bands?

Interference varies with time and location, and no band works perfectly in all conditions. Different bands are better for different kinds of interference. Lower frequency bands like 7 and 11 are typically better around rebar, passive interference, and salt water. The middle frequency bands have slightly stronger signal strengths that can perform better in deeper bores, plus have longer Target Steering capability. The highest bands have slightly less signal strength but tend to perform better around active interference such as power lines.

## Interference Check

Now that your transmitter is paired with your receiver, walk the bore with both the receiver and transmitter powered on to check for active interference on both frequency bands.

[Interference](#)

Page 39

[Changing Frequency Bands](#)

Page 63

## Calibrate

Perform a separate 1-point (**1PT**) calibration for each newly optimized frequency band in a low-noise area with the transmitter in a housing. Always calibrate after assigning a new frequency band.

[Calibration](#)

Page 14

If you paired two bands and want to be able to switch between them later, calibrate both bands.



## Above Ground Range Check

Perform an **Above Ground Range** check on the new optimized frequency band (or bands) before drilling. The AGR screen displays automatically after calibration.

[AGR](#)

Page 17

If the above-ground AGR distance at 15 m is not accurate, conduct a **15M** calibration (which also uses only one point) to improve the accuracy of the above-ground distance measurement. A 15 m calibration is *not* necessary for drilling.

[15M Calibration](#)

Page 18

## Drill

What are you waiting for? Start drilling. Or read on for more details and cool acronyms to know about the best locator on the planet.

# Receiver



**I know what a trigger switch is; can I skip this? [Page 13](#)**

This section is like shaking hands with your Falcon for the first time. If you and your receiver already have a solid relationship, you can probably jump ahead to [Receiver Menus](#).



**Falcon F5 Receiver – Side and Back Views**

## Overview

The DigiTrak Falcon F5 receiver (locator) is a handheld unit used for locating and tracking a Falcon transmitter. It converts signals from the transmitter to display depth, pitch, roll, temperature, and battery level, plus sends this information to the remote display on the drill rig.

The receiver and transmitter must meet specific operational requirements for different global regions. A regional designation number is located on the receiver's startup screen. This number must match the one stamped on the transmitter for proper communication.

[Startup Screen](#)

*Page 11*

Prior to use, the receiver must be paired to and calibrated with the transmitter.

[Calibration](#)

*Page 14*

## Toggle and Trigger Switches

The Falcon F5 receiver has two switches for operating the system: a toggle switch located on the top of the unit and a trigger located under the handle.

- Use the **Toggle Switch** to access and navigate menus.
- Use the **Trigger Switch** to turn on the receiver, select (click on) menu options, and change the screen view for depth readings. Pull and release (click) once, hold briefly and release, or use in combination with the toggle switch, depending on the desired action.

## Audible Tones

The Falcon F5 receiver beeps to signal power on/off, confirm menu changes, and acknowledge the pass/fail status of actions. The receiver also beeps with transmitter temperature increases.

[Transmitter Temperature Warning Tones](#)

Page 62

Two long beeps indicate a problem with the menu option selected and a failure screen will appear until you click the trigger or remove the battery (in the case of a critical failure). Verify your setup and try the operation again or contact DCI Customer Service for assistance.

## Startup Screen

Insert a charged battery pack. To power on the receiver, click the trigger. After you have read the warning screen, click again to acknowledge you have read and understand this manual. The receiver displays the startup screen:

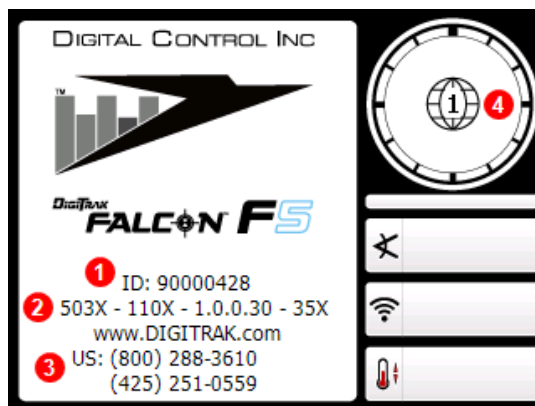

1. Receiver ID number
2. Software version
3. Customer service phone numbers
4. Regional designation number must match that of transmitter

**Receiver Startup Screen**

Click to exit the startup screen and open the Main menu.

[Receiver Menus](#)

Page 13



If an item of the self-test fails, a warning displays and a failure message appears in place of the system name. Please contact DCI Customer Service.



### Can I change the screen brightness?

No. The display is pre-tuned for optimal contrast and visibility in all conditions.

## Using the Keypad



Use the keypad for setting the height-above-ground (HAG) value, a target depth for Target Steering, date and time, and for programming rod lengths and survey points in the DataLog function.

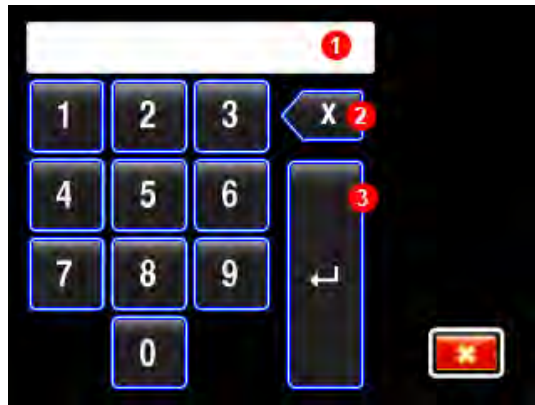

- 1. Display window
- 2. Backspace
- 3. Enter

**Standard Keypad**

To input a value, toggle to and select the desired digits from left to right. When a decimal value is required (such as for feet only or meters), then the last two digits entered will be to the right of the decimal point. To enter a whole value, enter two zeros at the end of the value. Use backspace to delete the last digit entered. Once the desired number is in the display window, select Enter to lock in the value and turn on the function.

## Your Remote Display

The Falcon F5 receiver is compatible with the following remote displays:

Remote Display	Minimum Software Version	Select on Remote Display
Falcon Compact Display - FCD	4.0	FalconF5
Multi-Function Display - MFD	3.0, F5 compatible	F5
F Series Display - FSD	all	F5
Aurora - AP8, AF8, AF10	all	Falcon F5 or F5

A remote display that accompanied your Falcon F5 receiver will already be set to communicate with your receiver.

If you purchased your Falcon receiver by itself, your existing remote display may not include the required option. If so, contact your regional DCI office or Customer Service for a software upgrade.

The operator's manuals for these remote displays are located on the flash drive that accompanied your Falcon system and also at [www.DigiTrak.com](http://www.DigiTrak.com). For an MFD, use the FSD manual.

## Receiver Menus



**I am already familiar with DigiTrak receiver menus; can I skip this? [Page 35](#)**

If you have used a DigiTrak F5 receiver, you are well on your way to mastering a Falcon. Read the section on the [Frequency Optimizer](#), then skip ahead to [Locating Basics](#). Come back and visit later as needed for reference. If this is your first DigiTrak, keep reading.

To access the Main menu from the Locate screen, toggle down. The Locate Mode icon is shown selected below; clicking the trigger would take you to the Locate screen.

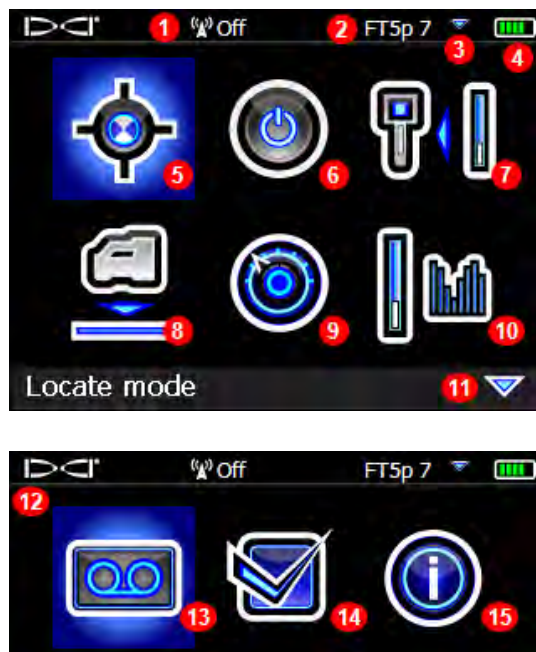

1. Telemetry channel
2. Transmitter type and frequency band
3. Band Up or Down
4. Receiver battery strength
5. [Locate Mode](#) (blue background = selected)
6. [Power Off](#)
7. [Calibration](#)
8. [HAG](#)
9. [Settings](#)
10. [Transmitter Selection](#)
11. Down arrow indicates second page below (toggle down to view)
12. Second page
13. [DataLog](#)
14. [Diagnostics](#)
15. [System Information](#)

### Receiver Main Menu

The top of the Main menu displays the telemetry channel, transmitter, transmitter frequency band, and receiver battery strength.

The following sections describe the Main menu items in order. Use the links above to jump straight to a section.



**Is there a faster way to get to the menu item I want?**

Yes, it's called screen wrapping. If you're at the top of a menu page, toggle up to jump to the bottom, or if you're at the left side, toggle left to jump to the right, and so on. To get from the top-left icon to the bottom right on the next page, you could toggle right-right-down-down, or just left-up. Yeah. Pretty cool.

## Locate Mode

When the receiver is detecting a signal from a transmitter, the Locate screen provides real-time data about the transmitter's location, temperature, pitch, roll, fluid pressure (when a fluid pressure transmitter is used), and signal strength.

[Locating Screens](#)

Page 36

## Power Off

Select **Power Off** from the Main menu to turn the receiver off. The receiver automatically shuts down after 15 minutes of inactivity, or after 30 minutes when in Target Steering mode.



**Is it okay to power off by pulling the battery out?**

Yes, your Falcon can handle it.

## Calibration and AGR

Use the **Calibration** menu to calibrate the receiver to a transmitter and to verify the Above Ground Range (AGR). Calibration is required prior to first-time use and before using a different transmitter, receiver, drill head, or transmitter band. Calibration is not necessary, however, when switching between bands on a transmitter that are already paired and calibrated.

Do not calibrate if:

- You are within 3 m of metal structures, such as steel pipe, chain-link fence, metal siding, construction equipment, automobiles, etc.
- The receiver is over rebar or underground utilities.
- An **A** is displayed at the top right of the roll indicator on the locating screen, as this indicates signal Attenuation is in effect, likely due to excessive interference. If possible, relocate to a quieter location before calibrating.
- The receiver is in the vicinity of extreme interference, as shown by high background noise readings on the frequency optimizer graph or an **A** at the bottom left of the graph, a flashing signal strength value on the locate screen, or a flashing A at the top right of the roll indicator (calibration is prohibited when these flashing indicators are present).
- The receiver is not displaying transmitter data.
- The signal strength from the transmitter is less than 300 points (too low) or greater than 950 points (too high). Outside this range, a calibration failure screen will indicate low or high signal strength.

[Attenuated Signal](#)

Page 67

[Frequency Optimizer](#)

Page 24

[Installing Batteries / Power On](#)

Page 59

**The transmitter must be installed in a drill head during calibration.**

During calibration, Height-Above-Ground (HAG) is automatically turned off. After calibration, HAG must be turned back on manually.

[Height-Above-Ground \(HAG\)](#)

Page 18

## 1-Point Calibration

This is the most common method of calibrating depth readings and is accomplished above ground, prior to drilling.

1. Place the receiver and the transmitter (in a drill head) parallel to each other on level ground, with both devices powered on.
2. With the receiver at the Locate screen, verify that roll and pitch values are being displayed and that a steady signal is being received from the transmitter. The transmitter's signal strength at calibration is available under **View calibration**. A change in signal strength at 3 m later can indicate you are currently in an interference environment or there is a problem with your equipment.
3. Move the locator within 0.5 m of the transmitter to enable signal [attenuation](#), indicated by an **A** at the top right of the roll indicator. Move the locator back to 3 m away and verify attenuation turns off. If it does not, excessive noise may be present. Due to its higher signal strength, a 19 in. transmitter must be moved more than 3 m away from the receiver before attenuation will turn off.
4. At the Main menu, select **Calibration**  and then **1 pt calibration**.



1. 1 pt calibration
2. In-Ground Calibration
3. View Calibration
4. Above Ground Range (AGR)

Calibration Menu

5. Use a tape measure to ensure the distance from the center of the transmitter to the inside edge of the receiver is 3 m as shown below, then click **Continue**  to begin the calibration.

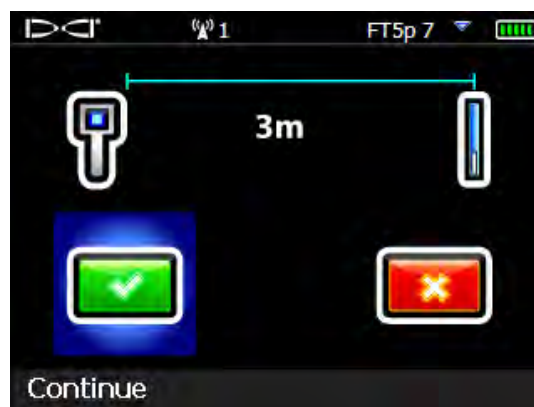

6. Do not move the receiver. A successful calibration yields a check mark  and four beeps.

Calibration can fail for one of three reasons:



**Transmitter signal is too low (below 300 points)**



**Transmitter signal is too high (above 950 points)**



**Extreme signal attenuation is in effect**

If calibration fails, review the items mentioned in the question titled "Why do I keep getting calibration errors?" below, read more about signal attenuation in [Appendix B](#) (if it applies), then click **Retry**  to try calibrating again.

After a successful calibration of one band, before proceeding to the AGR screen to verify above-ground distances for this calibration, the receiver briefly displays this icon:

[Above Ground Range \(AGR\)](#)  
Page 17



This simply means that one band has been calibrated, but one has not. After checking AGR for the current band, remember to calibrate and check the AGR of the other band.



### Why do I keep getting calibration errors?

Carefully review the items under "[Do not calibrate if](#)" at the beginning of this section. Try calibrating in a different location. Make sure the transmitter is on and paired (data showing on the Locate screen). If you're still having trouble, give us a call, we'll get you going.



If depth data does not display, hold the trigger while over the transmitter to display the locate line. For additional information on obtaining this reference lock ("R"), see step 4 in the discussion under [Finding the Front Locate Point \(FLP\)](#) beginning on page *Page 46*.

If you just completed AGR after calibration, don't forget to turn Height-Above-Ground (HAG) back on, if necessary.

[Height-Above-Ground \(HAG\)](#)  
Page 18

### In-Ground Calibration



This calibration procedure is rarely needed. If you find it necessary to calibrate with the transmitter in the ground, contact DCI customer service for information on this option, and perform this procedure with caution.



## View Calibration

Use this feature to check the most recent calibrations for your transmitter(s). The data will include the model of transmitter, type of calibration (1-point or in-ground/2Pt), signal strength, and a timestamp. Though this window lists all transmitters compatible with the Falcon F5 receiver, only transmitters calibrated to your receiver will display data in the Signal and Timestamp columns.

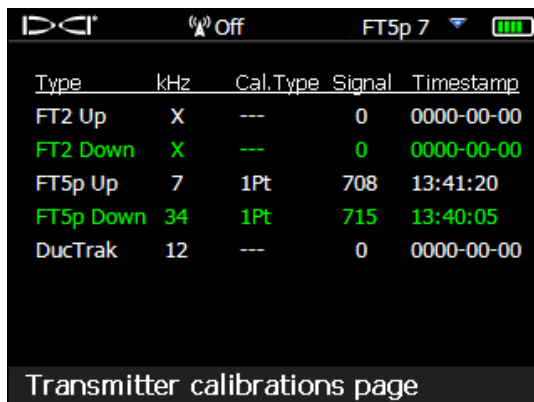

Type	kHz	Cal.Type	Signal	Timestamp
FT2 Up	X	---	0	0000-00-00
FT2 Down	X	---	0	0000-00-00
FT5p Up	7	1Pt	708	13:41:20
FT5p Down	34	1Pt	715	13:40:05
DucTrak	12	---	0	0000-00-00

Transmitter calibrations page

### View Calibration Window

After calibrating a fluid pressure transmitter, turning the fluid pressure feature on or off does not require a new calibration. However, a separate calibration is required for each frequency band if you want the option of switching between them mid-bore.

[Changing Frequency Bands](#)

Page 63

Click to return to the **Calibration** menu.

## Above Ground Range (AGR)

After successfully completing a 1-point calibration, the receiver displays the **Above Ground Range** screen, which is an active measurement between the transmitter and receiver. You can also access this tool directly from the **Main** menu > **Calibration** > **Above Ground Range (AGR)** . Use this screen along with a tape measure to verify calibration of the transmitter at different depths/distances. With the transmitter level, the depth readings should be within  $\pm 5\%$  of the measured distance.



### AGR: It's Just What You Do

Performing an AGR test on both frequency bands at every jobsite is just good practice.

Note that because AGR intentionally does not consider pitch when calculating range, it displays a symbol indicating "Warning, pitch is unknown, assume zero". It also ignores any HAG setting.

[Pitch Assumed Zero](#)

Page 37

Note that the **15 m calibration** button does not appear when the AGR screen appears immediately after calibration.

Use AGR at least daily, and ideally in both frequency bands, to verify proper depth/distance measurements.

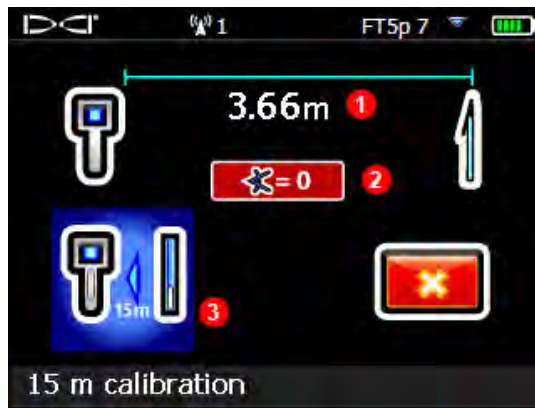

1. AGR
2. Pitch assumed zero
3. 15 m calibration

### Above Ground Range (AGR)

If you just completed AGR after calibration, don't forget to turn Height-Above-Ground (HAG) back on, if necessary.

[Height-Above-Ground \(HAG\)](#)

Page 18

### 15 m Calibration (Optional)

This feature is primarily used for demonstrations of the locating system above ground and is not necessary for drilling. Above ground range (AGR) measurements beyond 12.2 m often read shallower (shorter) than they actually are due to variations in ground conditions, and this feature calibrates these measurements to account for these variations. Using this feature is substantially similar to the procedure described for [1 pt calibration](#); if you require further information, please contact DCI customer service.

## Height-Above-Ground (HAG)

Use **Height-Above-Ground (HAG)** to set a height measurement on the receiver so you don't have to set it on the ground for a depth reading. Raising the receiver above the ground also provides separation from underground interference that might otherwise reduce the transmitter's range or cause variable readings.

To prevent incorrect readings, Falcon F5 always powers on with the HAG function off (disabled). HAG also automatically shuts off during calibration and is ignored during Target Steering and AGR tests. Until you enable HAG, the receiver must be placed on the ground for accurate depth readings.

[Calibration](#)  
Page 15

[Depth Units](#)  
Page 20

[AGR Test](#)  
Page 17

[Target Steering](#)  
Page 54



Prior to enabling HAG, verify accurate range/depth readings at a minimum of two points using AGR (see link above) or a regular depth reading (hold the trigger). If the transmitter is not properly calibrated, inaccurate depth readings will be made worse by an inaccurate HAG distance.

1. To determine your desired HAG distance, hold the receiver comfortably at your side, maintaining 20 cm of separation from the front of the receiver to your torso as specified in the Safety section on page 1. Measure the distance from the bottom of the receiver to the ground.
2. From the Main menu, select **HAG**. The HAG menu displays with **Enable HAG** highlighted and the current or 24 in. default HAG setting shown in the description line at the bottom of the screen. If the HAG had been enabled, **Disable HAG** would be highlighted.

## Turn HAG On



HAG Menu

3. If the HAG value shown at the bottom of the screen is acceptable, select **Enable HAG**. The receiver beeps four times as it enables HAG and returns to the Main menu. Skip the next step.
4. To change the HAG value shown at the bottom of the screen, select **Set HAG** and enter a new value. After you select **Enter** on that screen, the receiver beeps four times as it enables HAG and returns to the Main menu.

[Using the Keypad](#)

Page 12

Depth readings (holding the trigger) must now be taken with the receiver held at this height.

As noted above, to prevent incorrect readings, HAG must be manually turned on each time the Falcon F5 receiver is powered on.



**I use HAG all the time; can I set it to turn on automatically?**

No. In the name of safety, HAG must be turned on manually for each use. However, the feature does remember the last height value used.

## Settings

Use this menu to set the following options:

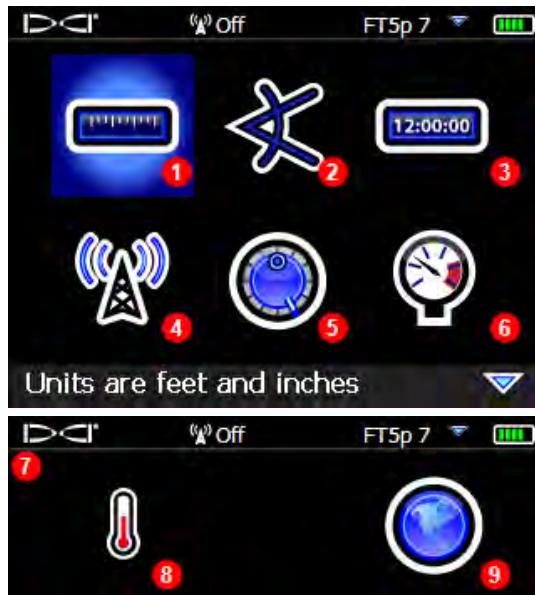

1. [Depth Units](#)
2. [Pitch Units](#)
3. [Date/Time](#)
4. [Telemetry Channel](#)
5. [Roll Offset](#)
6. [Pressure Units](#)
7. [Second page](#)
8. [Temperature Units](#)
9. [Language](#)

Settings Menu

DCI recommends that you program the receiver and the remote display Depth and Pitch settings to use the same units of measure.

### Depth Units Menu

Choose between **xx"** inches, **x'xx"** feet and inches, **x.xx'** decimal feet, and **x.xx m** metric units (meters and centimeters).

### Pitch Units Menu

Choose between **degrees (x°)** and **percent (x%)**. Typical HDD bores use percent pitch instead of degrees.

## Set Time and Calendar Menu

Set the time and date on your receiver. This is necessary when you are using the DataLog function.

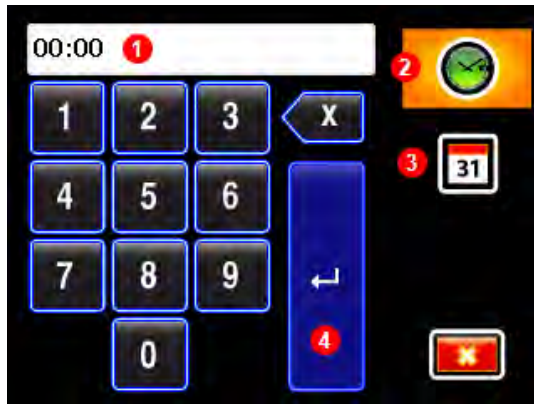

1. Time value (date displays here when calendar is the active function)
2. Time (shown active)
3. Calendar
4. Enter

**Time and Calendar Keypad**

### Setting the Time

The time function runs on a 24-hour clock. To set the time:

1. Select the time icon so it is the active function .
2. Enter the time one digit at a time from left to right. For example, to set the clock to 13:39 (1:39 pm), select "1", then 3, 3, and 9.
3. Select the blue Enter arrow.

### Setting the Calendar

The calendar function displays the date by month/day/year. To set the date:

1. Select the calendar icon so it is the active function . The display window on the keypad changes to show a date format.
2. Enter the date one digit at a time from left to right. The date format is MM/DD/YYYY. For example, to set the date to January 2, 2016 (01/02/2016), select "0", then 1, 0, 2, 2, 0, 1, and 6.
3. Select the blue Enter arrow.

## Telemetry Channel Menu

This menu has five telemetry channel settings (1, 2, 3, 4, and 0). For communication to occur between the receiver and remote display, both devices must be set to the same telemetry channel. The current telemetry setting is highlighted when this menu opens.

Select the desired telemetry channel on the receiver. To turn telemetry off and conserve receiver battery life, select "0". Channel 0 is also used when there are more than four receivers operating in the same area; using more than one receiver per channel within telemetry range of each other will cause conflicting signals to be sent to the remote display on the drill rig.

## Roll Offset Menu

### Enable Roll Offset

1. Select **Set and enable the roll offset**.



1. **Set and enable the roll offset**
2. **Disable roll offset**

### Roll Offset Menu

2. Ensure the drill head is at its 12:00 position and that the transmitter is on.

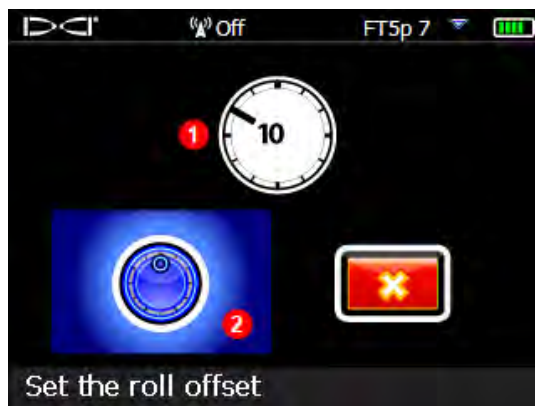

1. **Transmitter's true roll position with housing at 12:00**
2. **Set the roll offset**

### Set Roll Offset Menu

3. Select **Set the roll offset**.

If you need to know the original roll value later (perhaps to [change a transmitter frequency](#) in-bore as discussed on page 63), simply toggle to the Roll Offset option in the Settings menu, and if Roll Offset is enabled, the original roll value displays at the bottom of the screen after "Roll offset enabled".

When the roll offset function is enabled, the roll indicator will change to a circle and "RO" appears at the bottom left of the roll indicator.



### Roll Offset Activated

### ***Disable Roll Offset***

Select **Disable the roll offset** from the **Roll Offset** menu. The receiver beeps four times as the screen returns to the **Settings** menu. The value that displays for roll on the Locate screen will now be that of the transmitter, not necessarily the drill head.

### **Pressure Units Menu**



Choose between pounds per square inch (psi) and kilopascals (kPa).

### **Temperature Units Menu**



Choose between Fahrenheit (F) and Celsius (C).

### **Language Selection Menu**



This menu has multiple language options. Selecting a new language will cause the receiver to restart.

## Frequency Optimization and Transmitter Selection

This section addresses Falcon technology's ground-breaking frequency optimizer (FO) feature, which finds the lowest-noise (optimal) group of frequencies available in each of nine bands. When the results display in graph form showing the levels of active interference in each band, choose the one or two bands you want to use, pair, and you're ready to calibrate and start drilling.

You can switch the transmitter between the two optimized bands at any time, either pre-bore or mid-bore. Start in the optimized band that works best for the normal-interference portion of the bore and switch to the other band that works better for the portion that has higher interference. Or use one optimized band for the whole bore, or start drilling in one optimized band and switch only if you need to. The choice is yours.



### Do I have to optimize every time I power the receiver on? *Page 59*



No, the receiver remembers both optimized bands until you pair it to a new band. Power the transmitter on horizontally to use the last active band. But don't forget to optimize at your next bore.

### If my optimized band worked great at my last jobsite, can I keep using it at my next one?

Because sources of interference differ at every jobsite, DCI recommends optimizing at every jobsite to obtain the best selection of frequencies for the current conditions.

## Frequency Optimization

To optimize and select a frequency band:

1. Ensure all transmitters are powered off or are more than 30 m away from the receiver.
2. Take your receiver to the point along the proposed bore that you expect to have the greatest amount of noise (active interference).
3. With the receiver parallel to the bore path, open the Main menu, select **Transmitter Selection** , then **Frequency Optimization (FO)** .

When frequency optimization is complete, the receiver shows active noise readings in each of the nine frequency bands using an optimized selection of the lowest-noise frequencies within each band. The shorter the bar on the graph, the less interference present in that band.

-90 to -72 dB Low interference levels

-72 to -54 dB Moderate interference

-54 to -18 dB Interference will become an issue as depth increases



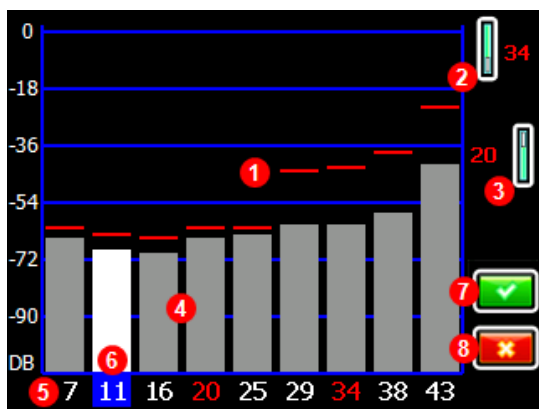

- 1. Maximum noise reading
- 2. Current Up band
- 3. Current Down band
- 4. Current optimized noise readings
- 5. Median kHz of each band
- 6. Band selector
- 7. Pair
- 8. Exit

**Frequency Optimizer Results**

4. To measure noise readings from the entire intended bore, simply walk the bore with the frequency optimizer results displayed, keeping the receiver parallel to the bore path. As the receiver continues sampling background noise, it marks the maximum noise reading of each band at the top of each bar.



**Optimize as often as you want. You can't wear it out.**

If noise levels rise substantially at any point along the bore, consider selecting and pairing one band (see next step) that performed well up to this point. Then select **Exit** and restart FO at this point to perform a new scan and select and pair a second band for use in this higher-interference area. Optimize as often as you want and wherever you want before assigning a band.

5. Toggle to the band you want to use and click to select. Typically this will be a band with a low interference level that did not experience high maximum noise readings along the bore path.

Band Number	7	11	16	20	25	29	34	38	43
Range in kHz	4.5 – 9.0	9.0 – 13.5	13.5 – 18	18 – 22.5	22.5 – 27	27 – 31.5	31.5 – 36	36 – 40.5	40.5 – 45

6. Select whether to assign this as the Up or Down band (the band the Tx powers on with when facing Up or Down).

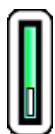

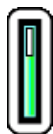

Up



Down



If the band number you want to use is already displayed at the right edge of the screen and marked in red on the bottom of the graph, select it anyway. The band you select now will be optimized with different frequencies than the last time that band was used.

7. Optional: click to select a second band, then assign as the opposite (Up or Down) band; changing both bands is not required.
8. Select **Pair** , then **Transmitter Pairing Request** . If you assigned two new bands, both will pair at the same time.
9. The receiver displays the transmitter pairing screen. Insert batteries in the transmitter, install the battery cap, and wait 15 seconds for the transmitter to fully power on.
10. Hold the infrared (IR) port of the transmitter within 5 cm of and facing the IR window on the front of the receiver.

[Transmitter](#)  
Page 58



1. Transmitter IR port

11. Select  again (we really like this icon) to pair the transmitter frequency band(s) to the receiver. Hold the transmitter in place for up to ten seconds for pairing. A blue circling icon indicates the receiver and transmitter are not yet connected; check alignment and proximity of the IR ports. Moving the transmitter during pairing may cause an error code to display on the screen; if this happens, simply restart the pairing process.





**Can I exit the pairing screen and go back to the optimizer results without running it again?**

Yes. Toggle left and select **Return to frequency graph** . Maximum readings will be reset and you can continue observing the noise readings of the last optimized frequency bands. Exiting from the frequency graph will erase optimization results.



When the pairing is successful, the receiver/transmitter icon briefly shows a happy green check mark and the receiver beeps. Both the receiver and transmitter are now using the new optimized band(s) you selected. If you assigned two new bands, the system defaults to using the Down band first.



- If the pairing is unsuccessful, the receiver/transmitter icon shows an unhappy red . Select **Repeat**  and try pairing a second time. If still unsuccessful, ensure you have the [correct transmitter](#) selected (page 27), remove and reinstall the transmitter batteries (positive end first) and battery cap, realign the two IR windows, and try again. If still unsuccessful, give us a call and we'll get you going.
- If the pairing doesn't complete, no new optimized frequency is stored in the receiver. Upon exiting the **Frequency Optimizer** screen, the receiver remains paired to the transmitter at the last optimized bands used. The last frequency optimization is saved and viewable under **View Frequency Optimization** .
- As mentioned at the end of step 4, the second band can be paired to a completely different optimization. If you just paired one band but want to re-optimize at a different location for the other band, simply run the frequency optimizer at the new location (step 1), select a band, and assign as the opposite (Up or Down) band.

## So I Just Paired, Now What?

After pairing, the receiver proceeds to the calibration screen as a reminder that with the selection of a new frequency band, the transmitter and receiver need to be calibrated. Install the transmitter in the drill head and calibrate.

[Calibration](#)

Page 14

Prior to calibration, "Calibration required" is indicated on the Locate screen by an error symbol in the roll indicator in place of the roll value. To change between bands mid-bore, both bands must be separately selected and calibrated prior to drilling.



Before or during drilling, switch between bands any time if interference is compromising the current band.

[Changing Frequency Bands](#)

Page 63

After pairing optimized frequency bands, for typical operations your next steps before drilling would be:

[Above Ground Range](#)

Page 17

- calibrate
- check Above Ground Range (AGR)
- check for background interference

[Interference](#)

Page 39

Complete each of these checks on both optimized frequency bands.

## Transmitter Selection



Use this option to select between a Falcon F5, Falcon F2, or DucTrak transmitter, as well as select the other band on your current transmitter.



**Transmitter Selection Menu**

After you select a different transmitter than is currently in use, the display returns to the previous screen.

If you select the same transmitter that is currently in use, the display continues to the Band Selection menu, where you can switch between the Up and Down bands, as well as enable or disable fluid pressure monitoring on an FT5p transmitter.



1. Up band
2. Fluid pressure
3. Down band

**Band Selection Menu**

To reach this menu directly from the Locate screen, hold the toggle right briefly. Select  to return to the Locate screen.

### View Frequency Optimization

Want to see what the active interference is right now on your optimized band? Sure you do.

Select either the Up or Down band icon. Falcon displays the current interference levels for the current optimized frequencies in that band. You may optionally select and pair a different optimized band from this screen. If so, remember to calibrate again prior to drilling.

### Transmitter Information

Use this option to read the details of your transmitter. It's also a handy way to double-check that the receiver is able to communicate (pair) with the transmitter.

Hold the infrared (IR) port of the transmitter within 2 in. of and facing the IR window on the front of the receiver, then select **Transmitter information request** . Upon a successful communication, the receiver provides the following information about the transmitter:

- Serial number
- Up band
- Down band
- Current (Amps)
- Voltage (V)
- Temperature
- Maximum temperature attained (lifetime)
- Software version
- Region (1 – 6)
- Model number

Click to return to the Main menu.

## DataLog

Use this menu to record pilot hole drill data, set up new drill jobs, view and delete drill jobs from the receiver, and upload drill jobs via Bluetooth to a computer for analysis with DCI's Log-While-Drilling (LWD) 3.0 software.

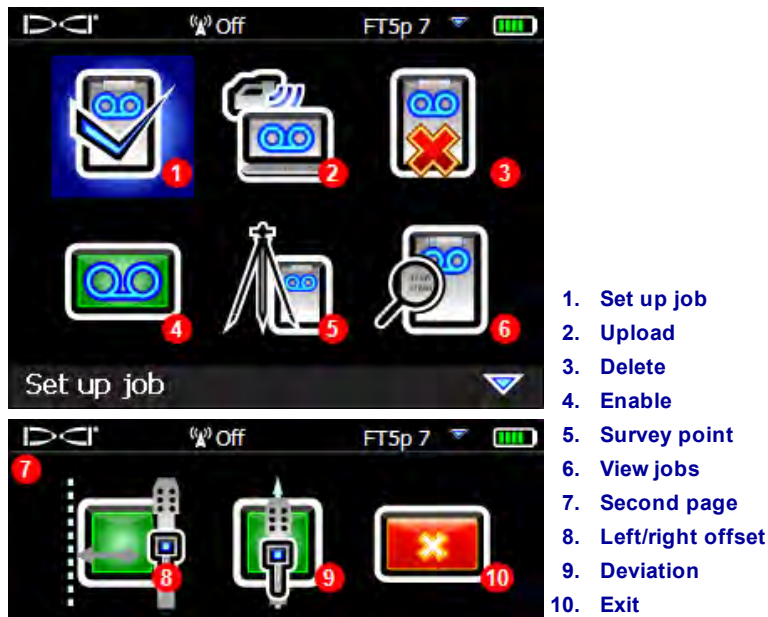

### Drill DataLog Menus

The LWD software has a variety of options for analyzing, editing, and displaying DataLog drill data. Complete instructions for using the advanced DataLog feature and the supporting LWD software are provided in the separate operator's manual and quick start guides available for DataLog/LWD at [www.DigiTrak.com](http://www.DigiTrak.com).

If you are already familiar with the DataLog feature, Falcon F5 includes four new functions requested by users like you: Left/Right Offset, Deviation, Flags, and Pins.

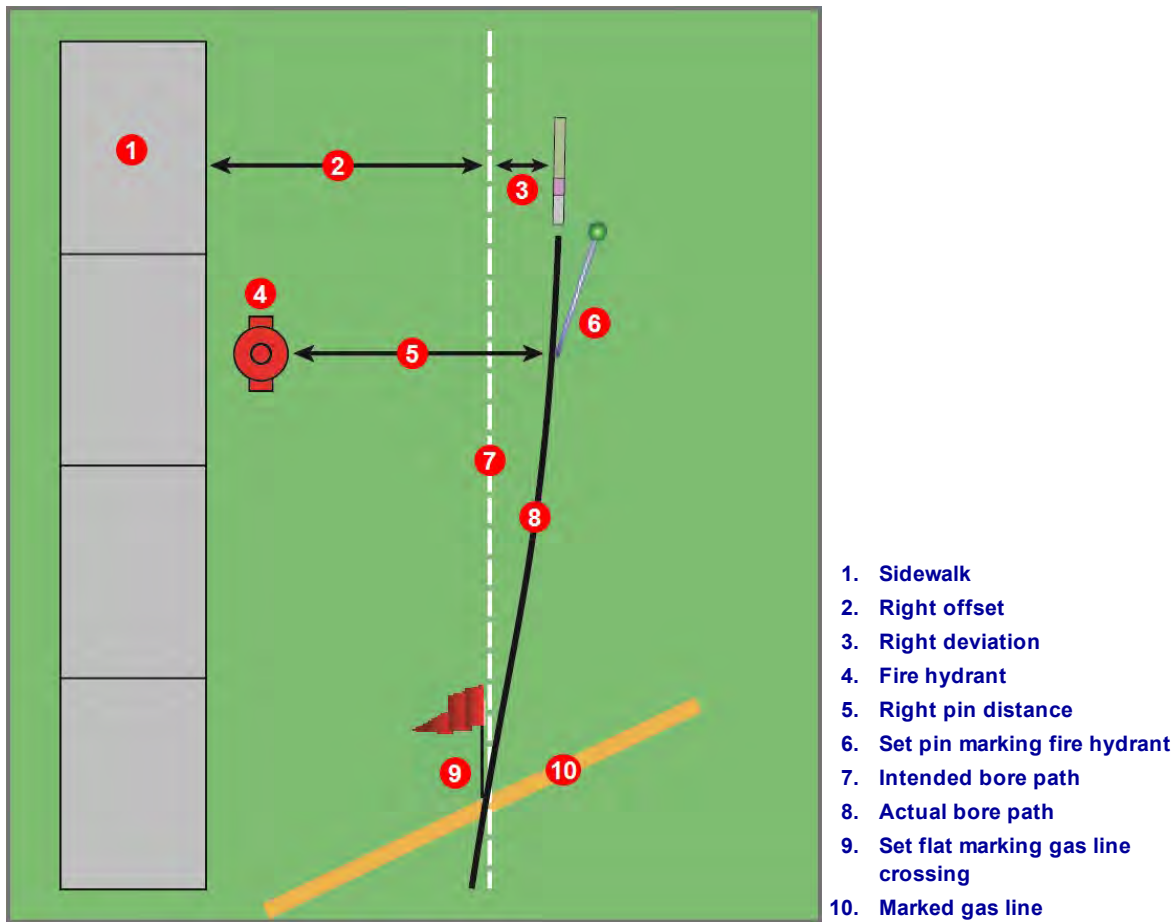

Left/Right Offset, Deviation, Flags, and Pins

### Left/Right Offset

On the **DataLog** menu, **L/R Offset** lets you specify a given horizontal distance you intend to maintain from a feature beside the bore path, such as curb, guardrail, or surveyed path. Think of this as a "running waypoint" that is recorded as long as the offset is in effect.

In the image above, the offset is a "right" offset, meaning the intended bore path is to the right of the sidewalk feature.

### Deviation

Also on the **DataLog** menu, **Deviation** lets you mark how far the drill head is deviating from the intended bore path. If an offset is in effect, it is how far the drill head is deviating from the offset.

Each time you log a rod at the Locate screen (hold trigger, toggle right), this feature lets you also record your current deviation from the bore path. For example, if you know you are supposed to be a certain distance from a guardrail but locate the drill head at a slightly farther distance, or are following a surveyed path and locate the drill head slightly to one side of the path, enter the difference as a left or right deviation.

## Flags and Pins

While recording a DataLog, at the Locate screen, toggle right to set a Flag or Pin. Match flags and pins later with entries in your drilling log book to add important detail to your Log-While-Drilling report.

### Flags

Select a **Flag** when crossing any item of interest along the bore path, like a sidewalk, marked utility line, or river bank. The receiver internally assigns a sequential flag number starting at 1. Enter the approximate distance along the current rod; the receiver will calculate the total horizontal distance of the flag based on the total number of rods already logged.

### Pins

Select a **Pin** to mark the location of a nearby land feature point (station mark, survey flag, fire hydrant, light post) that can help locate the bore path later. Setting a pin requires three pieces of data:

1. An identifying number. Use any number, like a survey station mark.
2. The approximate distance along the current rod (if halfway along a 10 ft. rod, enter 5 ft.).
3. The distance of the drill head to the right or left of the feature (perpendicular). In the preceding image, because the drill head is to the right of the fire hydrant "feature", the pin is recorded as to the right.

## Diagnostics

This menu lets you check the performance of your Falcon F5 receiver.

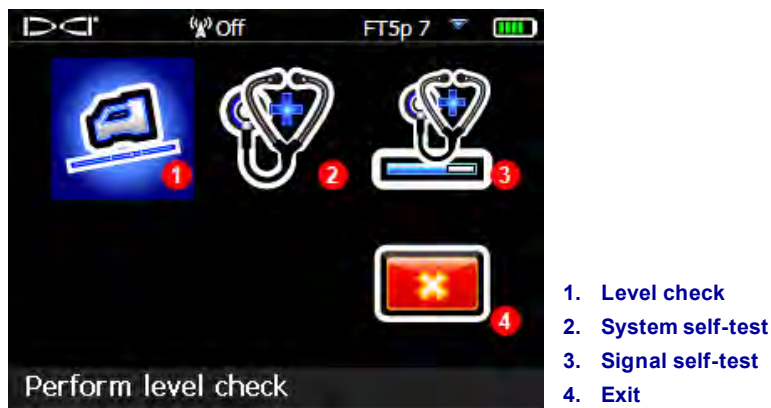

**Diagnostics Menu**

## Perform Level Check

This check confirms that the internal sensors that measure the inclination of the receiver are working correctly. An inaccurate sensor would cause erroneous depth and location readings.

Place the receiver on generally level ground and click **Continue** . The ground does not have to be perfectly level.

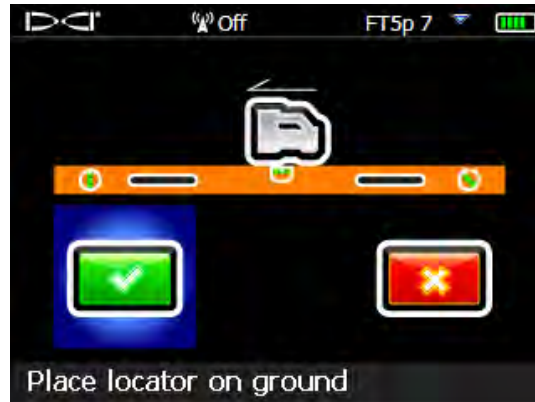

Level Test Screen 1

Rotate the receiver 180 degrees so it faces the opposite direction, as illustrated by the icon on the screen, and click **Continue**  again.

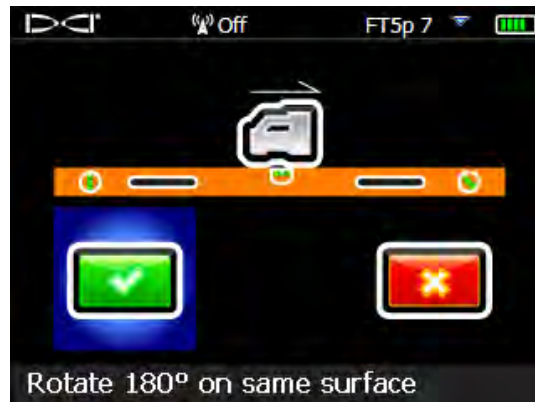

Level Test Screen 2

The receiver beeps four times, flashes a confirmation message, and returns to the Main menu.

If the level check fails, the receiver beeps twice and displays an error screen. Click **Retry**  and repeat the test as described above. If the check fails again, contact DCI Customer Service.

## Perform System Self-Test

This self-test performs a system check on internal components. Ensure no transmitters are powered on during this test. The receiver beeps four times after a successful test and displays the receiver [Startup Screen](#) (shown on page 11). Click to return to the **Diagnostics** menu.

If the receiver returns any other results, contact DCI Customer Service.



## Perform Signal Self-Test



This self-test tests antenna gain calibration for all transmitter frequencies. Ensure no transmitters are powered on during this test. Perform this test only in a low-noise environment with minimal interference. The transmitter signal strength as displayed on the [Locate Screen](#) (see page 36) must be less than 55 counts.

The receiver beeps four times after a successful test and displays the receiver [Startup Screen](#) (see page 11). Click to return to the **Diagnostics** menu.

If the receiver returns any other results, contact DCI Customer Service.

### **Potential test failures**

#### *Background noise*

If the test begins in an area with too much background noise, the test stops and the receiver displays a warning similar to **Background signal is too high**. Find a lower-noise area and try the test again.

#### *Test Loop*

If there is a problem with the depth antenna in the receiver, the receiver displays the error message **Fault: Depth Antenna Failure** on the Locate screen and locks the receiver. Contact DCI Customer Service.

#### *DSP channel failure*

In the event of a Digital Signal Processor (DSP) channel failure, the receiver displays the error message **Critical: DSP channels** on the Locate screen and locks the receiver. Contact DCI Customer Service.

## System Info

This menu displays technical system information such as ID, region, and numerous firmware versions. The numbers for BT (Bluetooth®) and ID (serial number) are necessary to move DataLog files to a PC. Click to return to the Main menu.



- 1. Serial number
- 2. Region
- 3. Primary software
- 4. Bluetooth
- 5. Second page

**System Info Screens**

# Locating Basics



**Are you ready? Page 39**

If you're new to locating and first want to know everything about the locating screens, you've come to the right place. If you already know locators and want to jump right in and start locating with your Falcon F5 system, skip to **Interference**.



## Locating in a High-Interference Area

This section covers locating basics:

- [Locating screens](#)
- [Checking for interference](#) and suggestions for dealing with it
- [Performing a roll/pitch check](#)
- Finding and marking [front and rear locate points](#) (FLP and RLP) and the locate line (LL) to pinpoint the transmitter
- The [geometry](#) of the FLP, RLP, and LL with respect to the transmitter
- Methods to [verify depth readings](#)



Refer to the DigiTrak YouTube site at [www.youtube.com/dcikent](http://www.youtube.com/dcikent) for helpful videos on these and many other locating topics.

## Locating Screens

The Locate, Depth, and Predicted Depth screens are the primary screens you will use for locating. The type of depth screen that displays depends on the position of the receiver relative to the transmitter at the time of the depth reading.



### Do I have to know all this? *Page 45*

Get this down first, then you'll be ready to locate like a professional. If you skip to [Locating the Transmitter](#) and feel like you're missing a little background information, come back here for a refresher.

For a description of the icons on the Locate screens, see [Appendix B](#) on page 67.

### Locate Screen

When the receiver is detecting a signal from a transmitter, the Locate screen provides real-time data about the transmitter's location, temperature, pitch, roll, and signal strength.

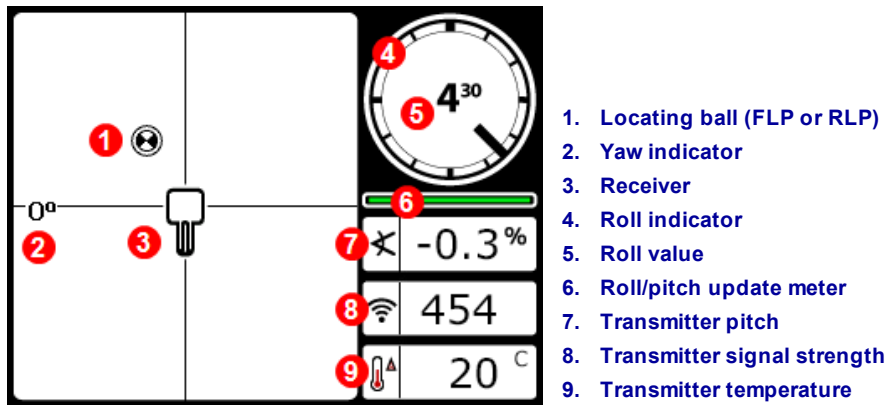

Locate Screen with Transmitter in Range

If the transmitter is on and there is no roll or pitch data, hold the trigger for 10 seconds to engage Max mode and the data should appear. If it doesn't:

1. The transmitter and receiver may not be on the same frequency band. Hold toggle right at the locate screen to select the other frequency band.
2. You may have the wrong transmitter model selected, such as FT2 instead of FT5p. From the Main menu, select **Transmitter selection** to choose a different transmitter.



### How do I check which frequency bands are assigned?

The current band in use is listed at the top of the Main menu (page 13). Hold toggle right at the Locate screen to see and switch between bands.

The roll/pitch update meter displays the quality of roll/pitch data being received from the transmitter. When the meter is empty, no roll/pitch data is being received, and none will appear on either the receiver or the remote display. Depth and predicted depth readings may still be taken, but the receiver will assume the transmitter has a pitch of zero, as indicated by the image to the right appearing on the Depth or Predicted Depth screen.



**Pitch Assumed Zero**

## Locate Screen Shortcuts

The following shortcuts are available from the Locate screen.

Task	Operation	Page
<a href="#">DataLog</a> (if enabled)	Hold trigger, toggle right	29
<a href="#">Depth Screen</a>	Hold trigger at locate line (LL)	37
<a href="#">Flag or Pin during DataLog</a>	Toggle right	31
<a href="#">Max Mode</a>	Hold trigger at least five seconds	37
<a href="#">Main Menu</a>	Toggle down	13
<a href="#">Predicted Depth Screen</a>	Hold trigger at front locate point (FLP)	38
<a href="#">Target Steering</a>	Toggle up	54
<a href="#">Band Selection Menu</a>	Hold toggle right	28

## Depth Screen

Hold the trigger with the receiver at the locate line (LL) to display the Depth screen.

[Locate Points \(FLP & RLP\) and Locate Line \(LL\)](#)

*Page 43*

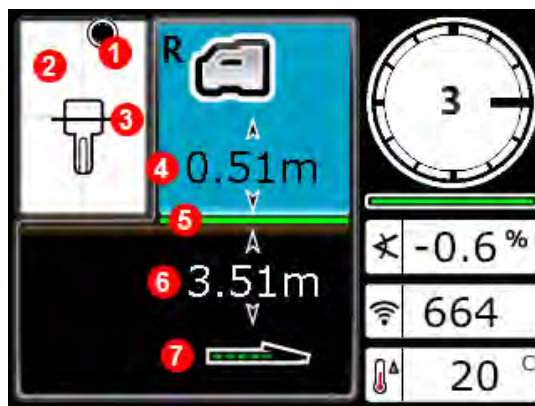

1. Locate point (front or rear)
2. Bird's-eye view
3. Locate line (LL)
4. Height-Above-Ground (HAG) setting on
5. Ground level
6. Transmitter depth
7. Tx battery strength

**Depth Screen at LL with HAG On**

When the HAG setting is disabled, the receiver will be shown on the ground and must be placed on the ground during depth readings.

[Height-Above-Ground \(HAG\)](#)

*Page 18*

### Max Mode Noise Filtering

The purpose of Max mode noise filtering is to stabilize erratic roll/pitch data, depths, and locates when drilling at the very limit of the ability of the transmitter due to extreme depth or interference, which will vary by jobsite.

When the roll/pitch update meter shows low signal level or data is erratic, hold the trigger for longer than five seconds to enter Max mode, indicated by a magnifying glass around the pitch icon.

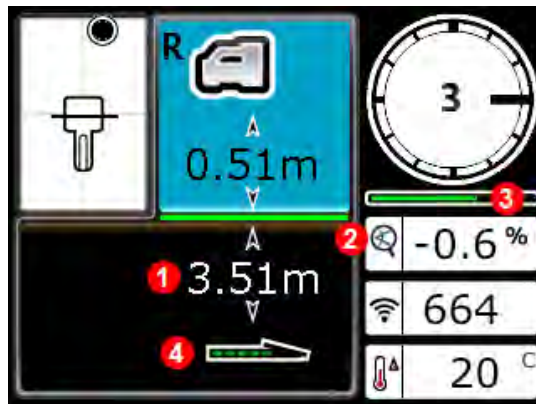

1. Depth
2. Max mode icon
3. Max mode timer
4. Tx battery strength

### Depth Screen in Max Mode

Max mode replaces the roll/pitch update meter with the Max mode timer. As you hold the trigger and Max mode gathers data readings, the timer slowly fills up. Greater interference or deeper bores will require a higher number of readings before roll/pitch data displays, or may prevent data from displaying altogether. If the timer is full and data is not yet stable, release the trigger, move to a different location near the drill head, and hold to restart. The timer bar will turn green as data is confirmed.

Always take **three** Max readings; all three readings must be identical and stabilize before the Max mode timer is full.



The drill head must be stationary when taking readings using Max mode. **If the drill head is moving, data readings will not be accurate.**

Due to the nature of the extreme depth and/or high-interference environment where use of Max mode will typically occur, the risk of obtaining unreliable data is higher. Never rely on data that does not display quickly and remain stable. Max mode is never a substitute for prudent operator judgment.

### Predicted Depth Screen



Because both [front and rear locate points](#) (see page 43) appear identical to the receiver, an invalid depth prediction can be generated when the receiver is over the rear locate point (RLP). Only a depth reading over the *front* locate point (FLP) produces a valid predicted depth.

Hold the trigger at the front locate point (FLP) to display the Predicted Depth screen. The predicted depth is the depth the transmitter is calculated to be at when it reaches the front locate point if it continues on its current path.

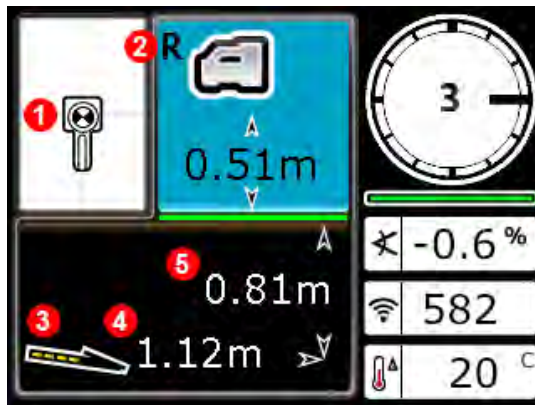

1. *Ball-in-the-Box™* at FLP
2. Reference Lock indicator
3. Tx battery strength
4. Horizontal distance between transmitter and FLP
5. Predicted depth of transmitter

**Predicted Depth Screen at FLP with HAG On**

Hold the trigger for longer than five seconds to enter Max mode, as described in the previous section (use of Max mode has special requirements and restrictions). In this example, if the drill head travels an additional 1.82 m at -0.2% pitch, it will be directly below the locator at 2.62 m.

### Depth Screen, Invalid Location

Hold the trigger at any time during locating to display the Depth screen. No depth or predicted depth will appear if the receiver is not positioned at the locate line or front or rear locate point. However, holding the trigger more than five seconds to enter Max mode may obtain more stable roll/pitch data (use of Max mode has special requirements and restrictions).

[Max Mode](#)  
Page 37

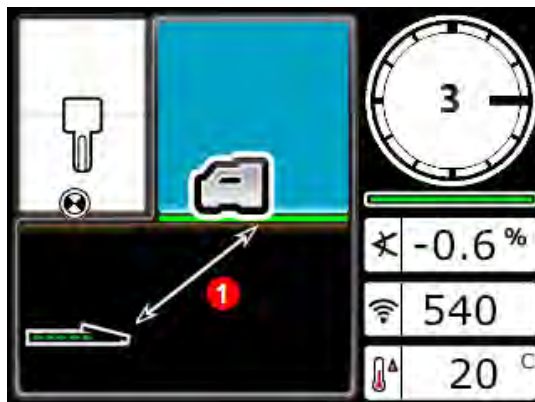

1. Slanted line indicates receiver is not at FLP, RLP, or LL

**Receiver Depth Screen with HAG Disabled (not at FLP, RLP, or LL)**

## Interference

Interference can compromise a transmitter's signal even when drilling with an optimized frequency band. It is important to the success of your bore that, after pairing your transmitter at a newly optimized frequency, you check how the transmitter's signal will perform along the intended bore path.



To best overcome interference, find and deal with it above ground, before you start drilling.

## What is Interference?

Interference can reduce the transmitter's range or cause variable readings and possibly result in job slowdowns. Interference is classified as either *active* or *passive*.

**Active interference**, also known as electrical interference or background noise, can have varying effects on locating equipment. Most electrical devices emit signals that can inhibit the ability to locate the transmitter accurately or get good roll/pitch readings. Example sources of active interference include traffic signal loops, buried dog fences, cathodic protection, radio communications, microwave towers, cable TV, fiber-trace lines, utility data transmissions, security systems, power lines, and phone lines. Interference at the remote display may also occur from other sources operating nearby on the same frequency. The following section describes how to use the receiver to test for the presence of active interference.

**Passive interference** can reduce or increase the amount of signal received from the transmitter, which results in incorrect depth readings, a completely blocked signal, or locates in the wrong position. Example sources of passive interference include metal objects such as pipes, rebar, trench plate, chain-link fence, vehicles, saltwater/salt domes, and conductive earth such as iron ore. The receiver cannot test for the presence of passive interference. Conducting a thorough site investigation prior to drilling is the best method of identifying passive interference sources.

To familiarize yourself with the interference potential along your intended bore path, check for background noise as discussed in the following section.



A receiver cannot detect sources of passive interference; this can only be accomplished with a visual inspection of the jobsite. A background noise check can only find *active* interference.



### I thought the Frequency Optimizer did all this for me?

The Frequency Optimizer finds the lowest-noise frequencies to use in each band. You choose which bands to use and pair the transmitter. As best practice, now test those bands above ground to ensure the receiver can receive data for the entire length of the bore. A good background noise check is vital to a job free of interference surprises.

## Checking for Interference

Ensure the receiver is on, optimized, and paired. Remove the batteries from the transmitter to turn it off and wait 10 seconds for it to fully power off. Now walk the intended bore path while viewing the current frequency optimization in the frequency band you intend to drill with. Take note of the bar graph height in the selected band. With no transmitter on, this "signal strength" is in fact background noise (active interference). Extreme background noise (interference) may cause signal [attenuation](#).



In the following figure, the red flag area denotes an increase in noise detected on the optimized band while walking the intended bore path.

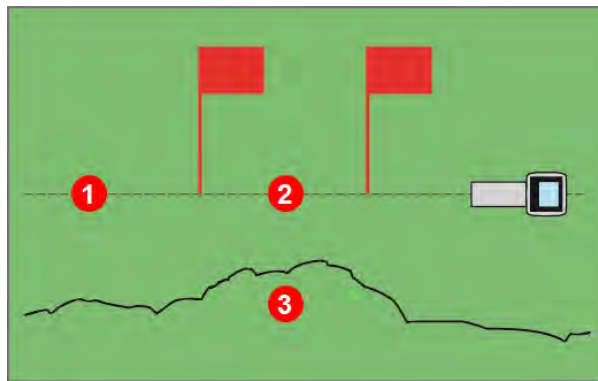

1. Intended bore path
2. Red flag area
3. Background noise signal

### One-Person Background Signal Strength Check (Transmitter Off)

Return to the area of highest interference (between the red flags above) and from the Locate screen, take a depth reading (hold the trigger) and note the signal strength. Power on the transmitter and place it the same distance to the side of the receiver as the intended bore depth. Verify that the roll/pitch data is consistent and correct in the flagged area. The transmitter's signal strength should generally be a minimum of 150 points greater than the background noise reading. For example, if this area of greatest interference produced a reading of 175, the reading with the transmitter on at this location, and at a distance from the receiver equal to the maximum intended bore depth, should be a minimum of 325 ( $175 + 150$ ).

Areas where the background noise level is too high may make it difficult to obtain roll and pitch data and accurate locates and depth readings. If the signal strength readings with the transmitter on were not at least 150 points greater than the background noise level, conduct a roll/pitch check as described in the following section.

Note that the transmitter's signal strength will be slightly higher in this test than while drilling because it is currently not encased in the drill head below ground, which will diminish the signal strength slightly.



An **A** displayed at the top right of the roll indicator at distances greater than 2.5 m from the transmitter means signal [attenuation](#) is in effect, indicating the presence of excessive interference that can lead to inaccurate depth readings.

### Roll/Pitch Check

At the exit of the bore, turn the receiver to face the entry and install batteries in the paired transmitter to turn it on. Have a coworker hold the transmitter and stand beside you. Walk together in parallel back toward the entry, keeping the receiver over the bore path and the transmitter at a distance of 1 to 1.5 times the current intended bore depth; where the bore is deeper, your coworker will be farther away. Periodically stop and change the transmitter's roll and pitch orientation so you can verify the speed and accuracy of these readings on the receiver. It is good practice to also have a coworker monitor the readings at the remote display at the same time. Note any locations where the receiver or remote display information becomes erratic or disappears. If roll/pitch data or signal strength become unstable, hold the trigger to see if Max mode can stabilize the data.

[Max Mode](#)

Page 37

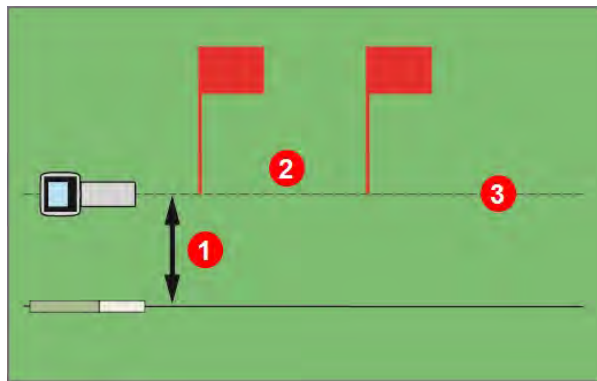

1. Intended depth
2. Red flag area
3. Intended bore path

### Two-Person Roll/Pitch Test with Transmitter

If the desired depth/data range in a red flag area is not sufficient, you may be able to increase the range by performing another frequency optimization here and pairing to a new band specifically for use in this high-interference location. If you do this, check for interference in this area again using the newly-optimized band. Use the other optimized band (Up or Down) for the non-flagged portion of the bore.

### Suggestions for Dealing with Interference

If roll/pitch information becomes erratic or is lost while drilling or during a roll/pitch check (see previous section), try one or more of the following:

- Try Max mode.
- Move the receiver away from the interference source while staying within range of the transmitter.
- Physically separate the receiver from both passive and active interference to reduce or eliminate interference-related problems.
- Switch to the transmitter's other frequency band.
- To overcome interference at the remote display, ensure the telemetry antenna is vertical and that the front of the receiver is facing the remote display. Set the receiver and remote display to use a different telemetry channel. An optional extended-range telemetry antenna may help overcome some forms of interference.

[Max Mode](#)

Page 37

[Off-Track Locating](#)

Page 51

[Height-Above-Ground](#)

(HAG)

Page 18

[Changing Frequency Bands](#)

Page 63

Never rely on the receiver as the sole means of communication between the receiver operator and drill operator. In cases where data is not available on the remote display, both operators must be able to communicate with each other.



In environments with extreme interference, the signal strength on the receiver may begin to flash red along with a flashing red **A** (Attenuation) at the top right of the roll indicator. This will also occur when the locator is too close to the transmitter (less than 1.5 m).

## Locate Points (FLP & RLP) and Locate Line (LL)

The Falcon receiver locates the transmitter by detecting three specific places in the transmitter's magnetic field: the front locate point (FLP) ahead of the transmitter, the rear locate point (RLP) behind the transmitter, and the locate line above the transmitter itself. The two locate points are indistinguishable from one another by the receiver as they represent similar points in the transmitter's field in front of and behind the transmitter (see [Appendix C: Projected Depth Versus Actual Depth and the Fore/Aft Offset](#) on page 69 for more information about the transmitter's magnetic field).

The locate line (LL) extends 90° to the left and right of the transmitter (perpendicular) when the transmitter is at 0% pitch. It represents the location of the transmitter between the FLP and RLP. If you think of the transmitter being the body of an airplane, its wings are the locate line.



### Locate line does not equal the location of the transmitter.

Being over the locate line does not mean you are over the transmitter, which may be to the left or right anywhere along the locate line. You must find the front and rear locate points to find the transmitter, as is detailed on the next couple pages.

The most accurate tracking requires the use of all three locations to determine the position, heading, and depth of the transmitter. A line passing through the FLP and RLP reveals the heading and left/right position of the transmitter. The LL determines the position of the transmitter when the receiver is properly aligned between the FLP and RLP (on the line).

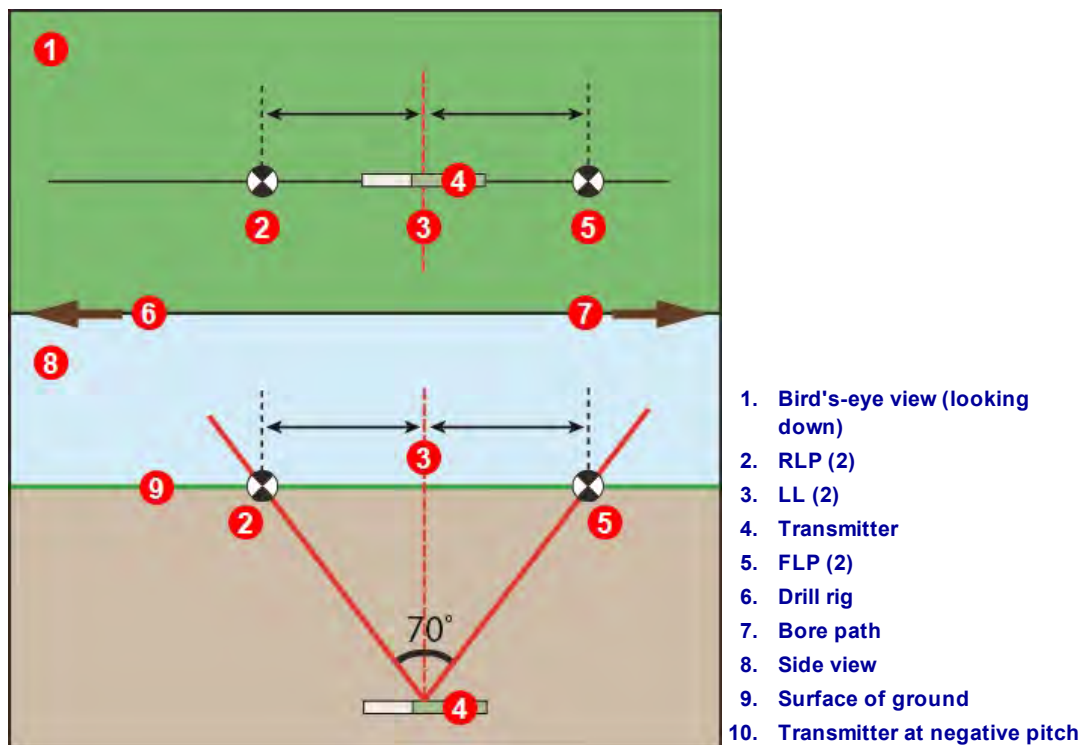

Geometry of FLP, RLP, and LL from Top (Bird's-Eye) and Side Views

Note how the RLP and FLP are equal distances from the LL when the transmitter is level.

The line marked LL in the bird's-eye view image suggests the receiver will display a locate line any time it is positioned on this plane. To prevent inaccurate locates and potentially dangerous conditions, it is imperative to first find the front and rear locate points. Do not rely on the peak signal along the locate line.



Whenever the transmitter is pitched, the position of the locate line will be somewhat slightly ahead of or behind the transmitter's actual position. This slight fore/aft offset will increase with depth (see [Appendix C: Projected Depth Versus Actual Depth and the Fore/Aft Offset](#)). In these cases, the depth displayed on the receiver is referred to as the projected depth.

### Effects of Depth, Pitch, and Topography on Distance Between FLP and RLP

The deeper the transmitter is, the farther apart the FLP and RLP will be. The distance between the FLP and RLP with respect to the location of the LL is also affected by transmitter pitch and the topography.

When the transmitter pitch is negative, the FLP will be farther from the LL than the RLP. When the pitch is positive, the RLP will be further from the LL than the FLP. If the ground surface or topography slopes significantly, the locations of the FLP and RLP will also be affected with respect to the LL even if the transmitter itself is level.

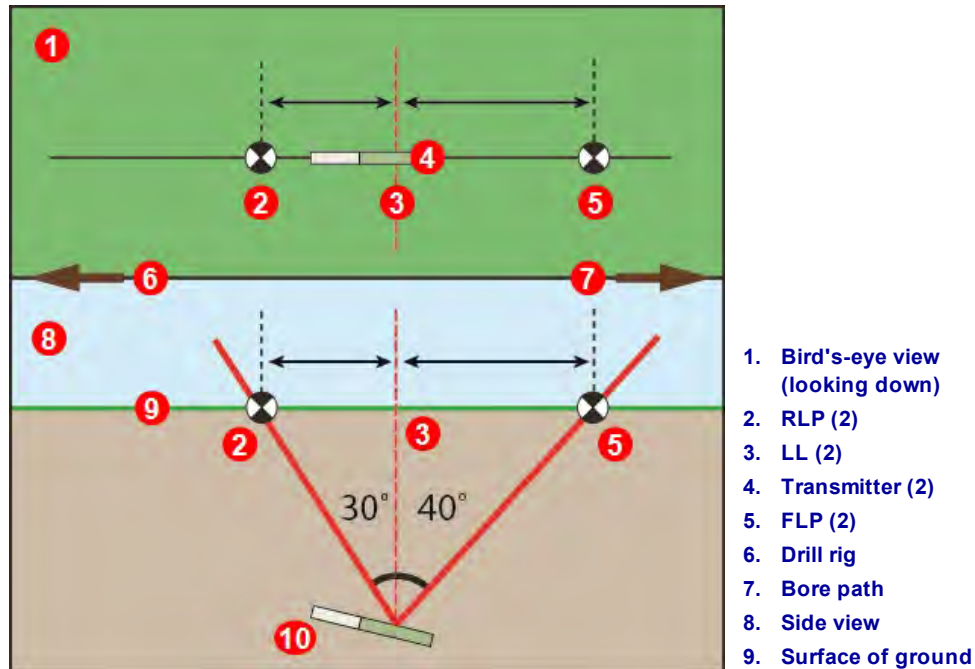

**Effect of Pitch on Distance Between FLP, RLP, and LL**

For a detailed explanation of how to track the transmitter when it is steep and deep, see [Appendix C](#) on page 69.

To calculate depth (for comparison to the receiver's depth reading) using the distance between the locate points and the pitch of the transmitter, see [Appendix D: Calculating Depth Based on Distance Between FLP and RLP](#) on page 73.

## Marking Locate Points

The locate points (FLP and RLP) and the locate line (LL) must be found and accurately marked during the locating procedure. To mark a locate point, stand with the receiver level at the locate point. Look down the vertical axis that runs through the center of the display to project a plumb line to the ground. Mark where this plumb line hits the ground.



1. Plumb line or vertical axis
2. Center of display
3. Front of receiver
4. Place marker straight down on ground

**Plumb Line for Marking Locate Points**

## Locating the Transmitter

Falcon can locate the transmitter *and* its heading while it moves, whether in front of the transmitter, behind it, or beside it. It can locate the transmitter while facing toward or away from the drill rig.

The standard method described in this section guides the receiver to the transmitter while standing in front of it, facing the drill rig. This is the recommended method for locating. As you continue to drill or as the bore path curves, you may be facing the last marked locate point rather than the drill rig.

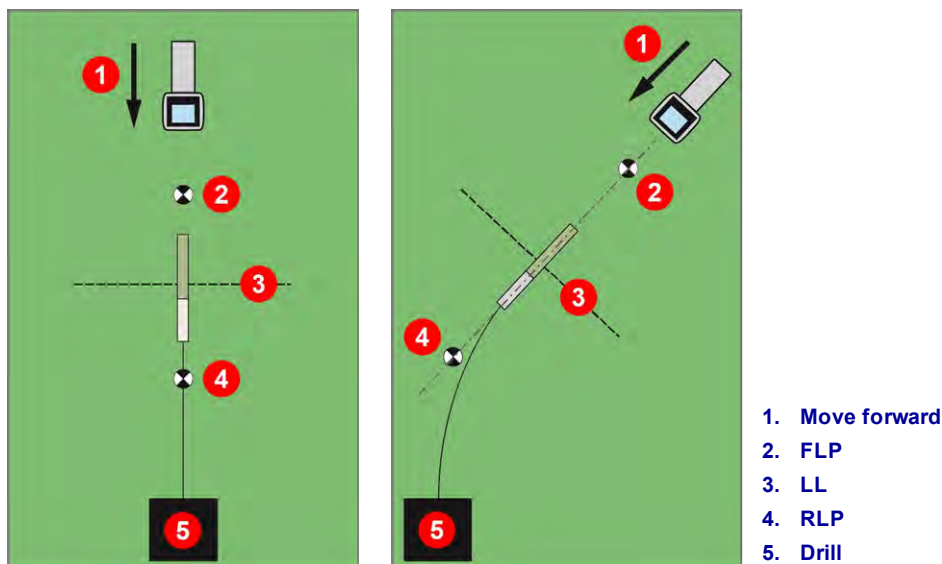

1. Move forward
2. FLP
3. LL
4. RLP
5. Drill

**Standard and Curved Path Locating**



**Go watch some TV**

You can find a training video on **Basic Locating** at [www.youtube.com/dcikent](http://www.youtube.com/dcikent).

## Finding the Front Locate Point (FLP)

The locating procedure described here assumes that (a) you are facing the drill, (b) the transmitter is below ground and between you and the drill, and (c) the FLP is in front of you.

1. With the receiver on and in Locate mode, stand in front of the drill head at a distance of approximately the depth of the drill head.
2. Observe the position of the locating ball  relative to the receiver box on the display. The figures below show the FLP ahead of and to the left of the receiver; as the drill head gets deeper, the FLP will be found farther in front of the transmitter.

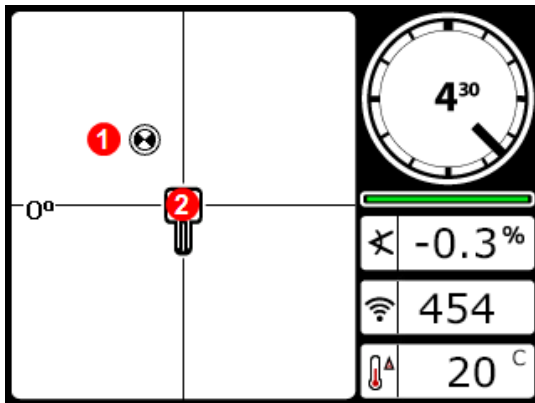

Receiver Locate Screen

Drill rig  
 ↑↓  
 Bore path

1. Locating "target" ball
2. "Box"

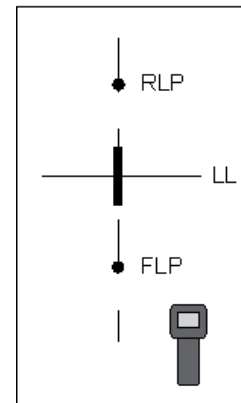

Actual Position of Receiver and Transmitter

3. Move the receiver to guide the ball into the box.
4. When the ball is centered in the box (*Ball-in-the-Box™*), hold the trigger for at least one second so the receiver can lock onto the reference signal. The **R** icon will appear at the top of the Depth screen. The locate line (LL) will not display later without this reference.

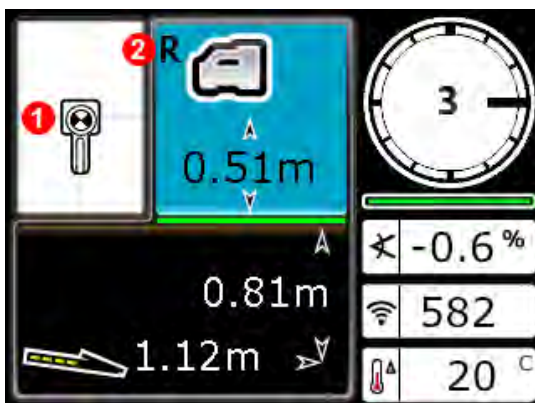

Receiver Predicted Depth Screen at FLP with HAG On

Drill rig  
 ↑↓  
 Bore path

1. Target *Ball-in-the-Box™*
2. Reference lock indicator

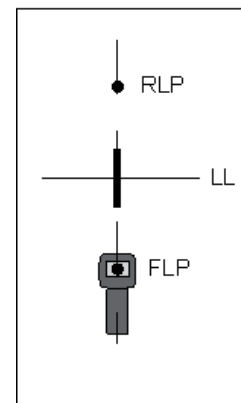

Actual Position of Receiver and Transmitter



When setting a reference signal, do not hold the trigger unless you are *Ball-in-the-Box*™ at the FLP. If you are ahead of the FLP, you could set an incorrect reference that causes a ghost locate line. This typically happens when the head is shallower than 1 m. In this case, you must reference again at the FLP.

If you hold the trigger for longer than five seconds, the receiver will enter [Max mode](#), which performs differently than a normal depth reading.

The depth value given at the FLP is the predicted depth, which is the depth the transmitter is calculated to be at when it reaches the location beneath the receiver. If the pitch or heading of the transmitter changes before it reaches the location under the receiver, the predicted depth reading will no longer be accurate.



### Quick receiver self-check

To verify that the signal is balanced through the receiver's antenna, carefully rotate the receiver 360° about the center of the display while keeping the receiver level. The locating ball should stay centered in the box. If it does not, do not continue to use the receiver and contact DCI Customer Service.

- With the ball centered in the box, mark the ground directly below the receiver's display screen as the FLP.

### Finding the Locate Line (LL)

- Continue walking toward the drill rig or the last known transmitter location. Keep the locating ball on the vertical crosshair and observe that the signal strength is increasing as you get closer to the transmitter.

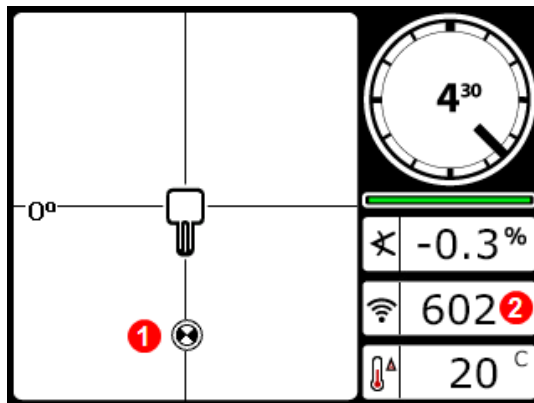

- Locating ball moving along vertical crosshair
- Signal strength higher than at FLP

Receiver Locate Screen, Moving Toward LL, FLP Behind

If the signal strength decreases, you may actually have just located the RLP. Position yourself farther away from the drill and start over at step 2.

- When the locating ball reaches the bottom of the screen, the locate line appears and the ball turns solid black to indicate your focus should now be on the LL.

If the locate line does not appear and the ball flips to the top of the screen, hold the trigger while moving the receiver in a forward/backward direction over where the ball flips. This action should re-reference the receiver to the transmitter's signal and bring up the locate line. If it does not, return to the FLP to re-reference (see step 1).

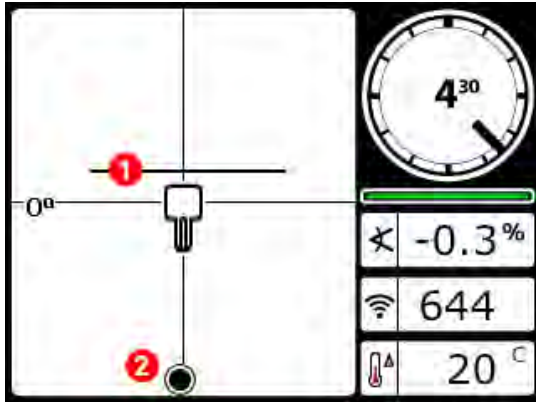

**Receiver Locate Screen, Approaching LL**

Drill rig  
 ↑↓  
 Bore path

- Locate line
- Locating ball

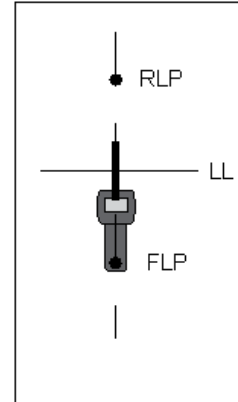

**Actual Position of Receiver and Transmitter**

Do not rely on the alignment of the ball with the vertical crosshair to identify the left/right position of the transmitter. Accurately locating the front and rear locate points is required to determine the transmitter's lateral position (heading) and take accurate depth readings.

- Position the receiver so the LL aligns with the horizontal crosshair.

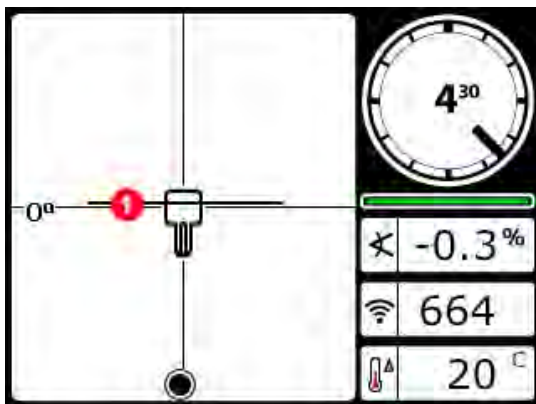

**Receiver Locate Screen at the LL**

Drill rig  
 ↑↓  
 Bore path

- Line-in-the-Box

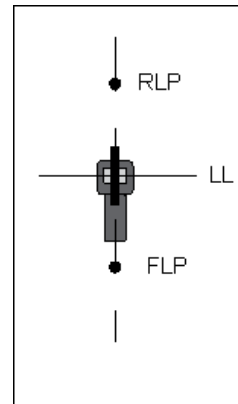

**Actual Position of Receiver and Transmitter**

- Take a depth reading and mark the LL directly below the receiver's display screen. If the FLP is to the left or right of the previous marks—indicating some steering action—locate the RLP as described in the next steps to verify proper positioning of the LL between the Locate Points.





**If the bore path is straight, do I have to keep finding the RLP for every rod? Page 46**

No. If a new FLP is directly in line with the previously marked FLPs (a straight bore line), it is unnecessary to find a new RLP since it will be directly in line with the previous marks. After the drill head moves forward another rod, find the new FLP and then the LL.

### Finding the RLP to Confirm Transmitter Heading and Position

Finding the RLP will allow you to confirm the transmitter's heading and position. Like the FLP, the RLP is represented as a ball  on the receiver display.

Continue locating:

- From the LL, facing toward the drill or last transmitter location, walk forward while keeping the ball aligned on the vertical crosshairs. Notice how the signal strength decreases as you move away from the transmitter.

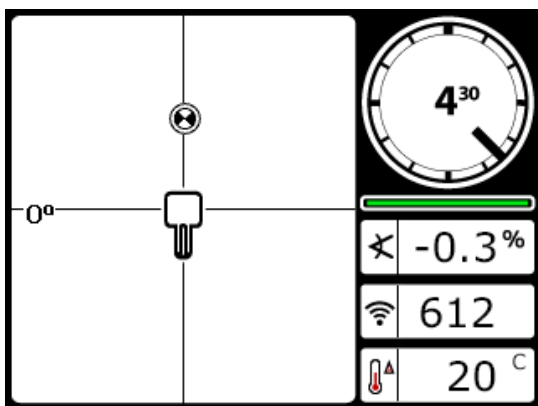

**Receiver Locate Screen, Approaching RLP from LL**

Drill rig  
↕  
Bore path

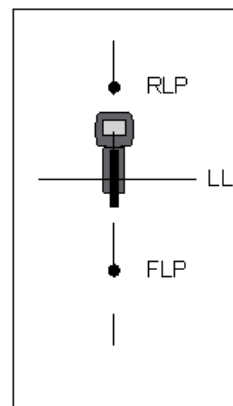

**Actual Position of Receiver and Transmitter**

- Position the receiver so the ball is centered in the box (*Ball-in-the-Box™*).

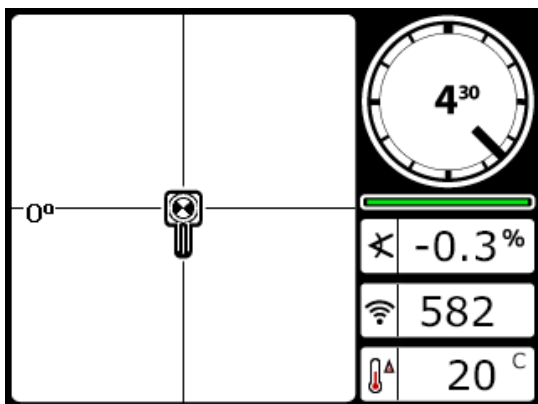

**Receiver Locate Screen at RLP**

Drill rig  
↕  
Bore path

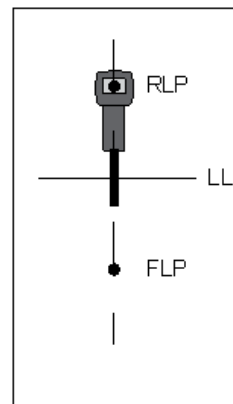

**Actual Position of Receiver and Transmitter**

12. Mark the ground directly below the receiver's display screen as the RLP. A line between the RLP and FLP represents the transmitter's heading.
13. Position the receiver at the intersection of this heading line with the LL passing through the center of the box on the display and hold the trigger to take a depth reading. This is the current location of the transmitter.

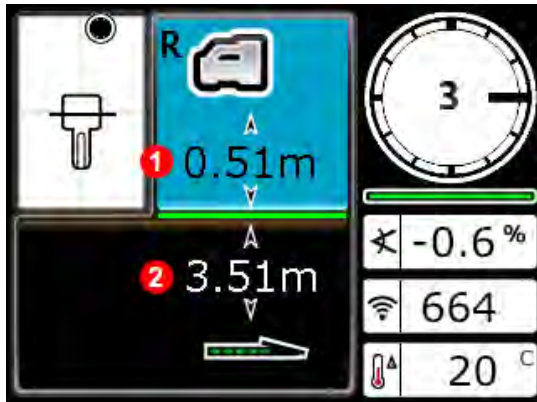

Receiver Depth Screen at LL

- Drill rig  
 ↑↓  
 Bore path
1. HAG on
  2. Corrected depth
  3. With LL aligned in box, receiver may face toward RLP or FLP during depth readings

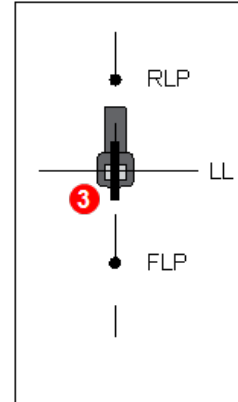

Actual Position of Receiver and Transmitter

### Three Methods to Verify Depth Reading

Disable HAG, set the receiver on the ground, and take another depth reading. This reading should be within 5% of the depth reading obtained with the HAG on and the receiver lifted. In the prior example, the reading should be 2.62 m.

or

With HAG on, set the receiver on the ground and add the HAG to the depth shown. It should also be 2.62 m.

or

If HAG is not being used, note the depth on the ground and then raise the receiver exactly 1 m. The depth reading should increase this same distance. In the example above, the depth would be 3.62 m.

See [Appendix C: Projected Depth Versus Actual Depth and the Fore/Aft Offset](#) on page 69 and [Appendix D: Calculating Depth Based on Distance Between FLP and RLP](#) on page 73 for more information on depth.

# Advanced Locating



## When you're ready to be the expert

Here are some techniques that will help you drill more productively and get past the bore that had everyone else scratching their heads and calling the home office.

## Tracking “On-the-Fly”



### Go watch some TV

You can find a training video on **Tracking On-the-Fly** at [www.youtube.com/dcikent](http://www.youtube.com/dcikent).

If you are running at 0% (0°) pitch under level ground, the predicted depth will be the actual depth. In this case, all locating can be done at the FLP while the drill head is moving.

Once the transmitter has been located and it is moving in the correct direction, place the receiver relatively level on the ground one rod length in front of the FLP, in line with the path created by the FLP and RLP. Turn HAG off.

[Height Above-Ground \(HAG\)](#)

Page 18

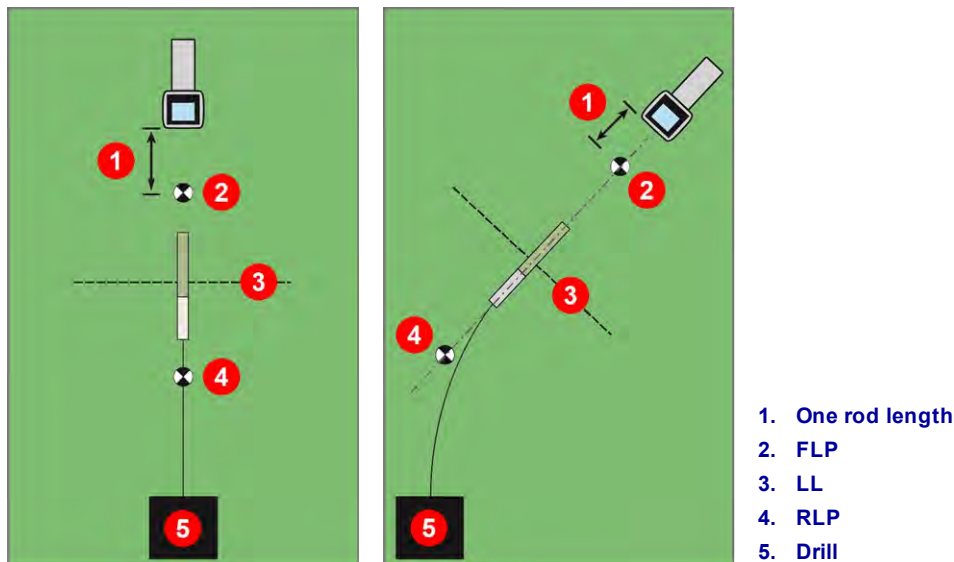

Tracking "On-the-Fly" with a Straight and Curved Path

As the drill head advances, the FLP should travel along the receiver's vertical crosshairs, indicating the drill head is still on line. Once the FLP is in the box, hold the trigger and confirm that the predicted depth reading is as expected.

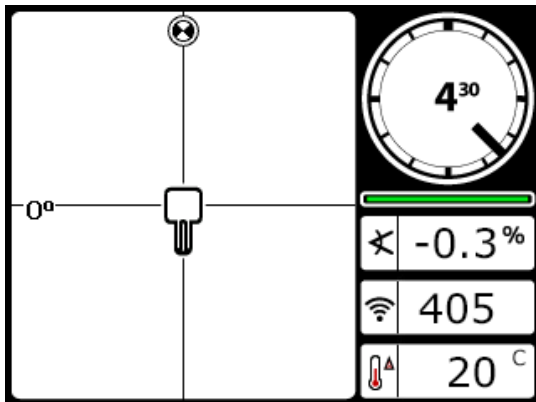

Receiver Screen Tracking "On-the-Fly"

Drill rig  
 ↑↓  
 Bore path

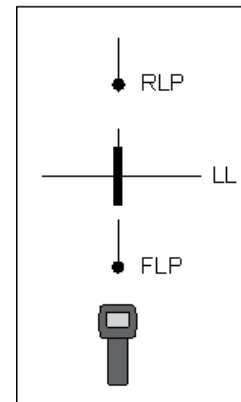

Actual Position of Receiver and Transmitter

Move ahead the length of another drill rod and wait for the FLP to continue advancing down the vertical crosshair.

## Off-Track Locating



### Go watch some TV

You can find a training video on **Off-Track Locating** at [www.youtube.com/dcikent](http://www.youtube.com/dcikent).

Use off-track locating when it is not possible to walk above the transmitter due to a surface obstruction or interference. Using the locate line's perpendicular relationship to the transmitter, it is possible to track the transmitter's heading and also determine if it is maintaining its intended depth. The off-track locating method is only effective when the pitch of the transmitter is 0% (0°) and traveling under flat ground.

To explain how the off-track locating method works, consider the example of an obstruction that is on the intended bore path, as shown in the figure below. The transmitter is about to go under the obstruction.

1. Stop drilling and find the locate line (LL) of the transmitter by putting the line in the box.
2. While holding the receiver in the same orientation, step to the side until you reach a predetermined distance (P1). Move the receiver forward and backward until the ball jumps between the top and bottom of the screen, then mark this location and note the signal strength. While still holding the receiver in the same orientation, do this two more times for off-track points P2 and P3.

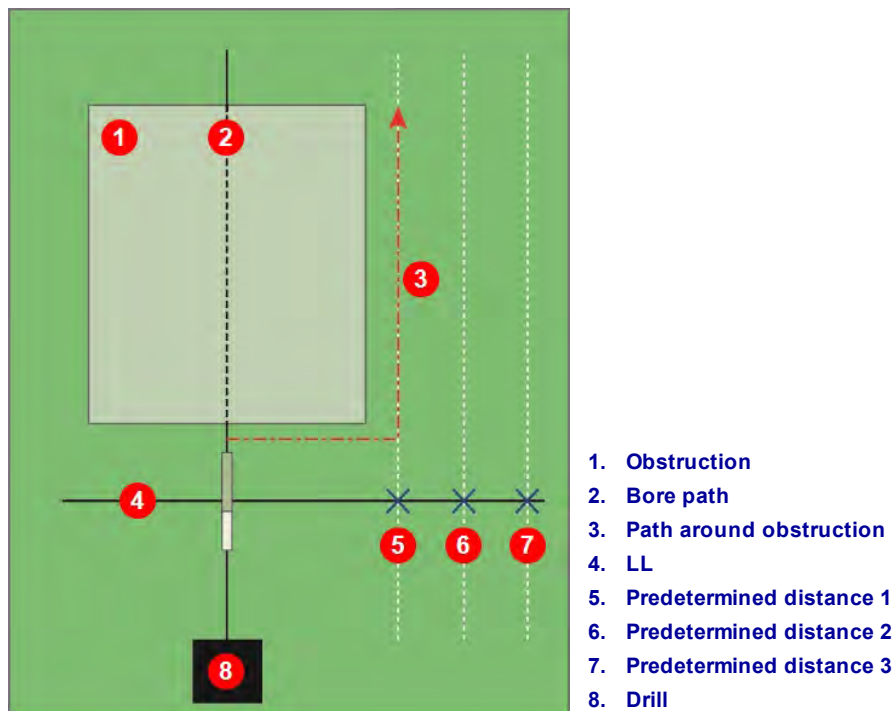

### Preparing for Off-Track Locating

3. Connect points P1, P2, and P3 with a line. This is the locate line. Because the LL runs perpendicular (at a 90° angle) to the transmitter when the transmitter is level, you can determine the heading of the drill head. By comparing the signal strength at the predetermined distances of P1, P2, and P3 as the drill head progresses, you can verify it is moving away from or maintaining the intended bore path. It is important to monitor the pitch of the transmitter to ensure the drill head is maintaining the desired depth.
4. As drilling continues, steer the drill head to maintain a constant signal strength at each of the points P1, P2, and P3. If the signal strength decreases, the drill head is moving away (to the left in the image below); if it increases, the drill head is moving closer to the side position (to the right).

Differences in pitch and topology elevations will also affect the signal strength and LL position as the drill head progresses. Using three (or more) off-track points gives you more information to help recognize the potential adverse effects of interference at any one point.

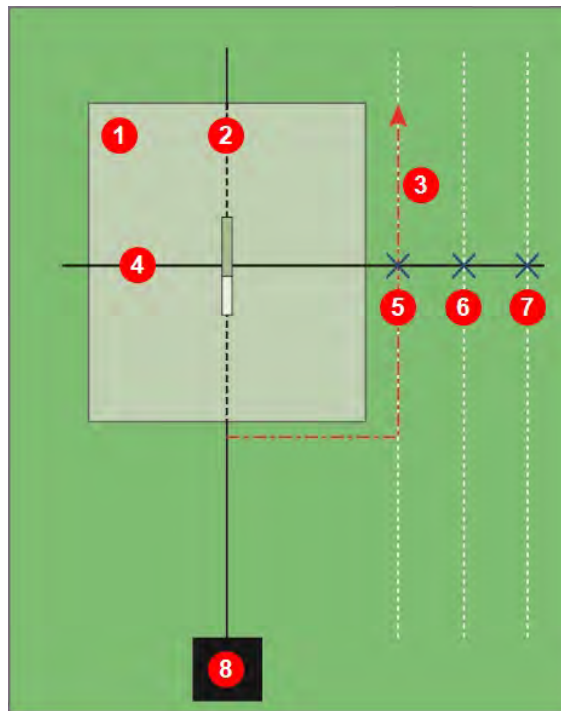

1. Obstruction
2. Bore path
3. Path around obstruction
4. LL
5. Predetermined distance 1
6. Predetermined distance 2
7. Predetermined distance 3
8. Drill

Off-Track Locating

## Target Steering

The Target Steering<sup>®</sup> locating method allows the Falcon receiver to be placed ahead of the drill head and used as a steering target.

In general, Target Steering should be used to *maintain* a bore path, not to correct a significantly off-course bore. If needed, use front and rear locate methods to get back on course.

[Locate Points \(FLP & RLP\) and](#)  
[Locate Line \(LL\)](#)

Page 43

In situations with significant pitch changes, such as during the entry/exit or areas with changing topography and elevations, the up/down steering information on the remote display may not be accurate. In these situations, only the left/right steering information should be considered accurate.



After learning the concepts of Target Steering, practice its use *before* using on a jobsite where time and money are at a premium. If you need further assistance, please contact DCI Customer Service.



### Go watch some TV

You can find a training animation on **Target Steering** at [www.youtube.com/dcikent](http://www.youtube.com/dcikent).

Using the receiver for Target Steering requires a stable signal from the transmitter.

Target Steering will not work properly with passive interference in the vicinity of the bore.

[Interference](#)

Page 39

## Feasible Target Steering Area

The maximum distance the receiver can be placed ahead of the drill head for Target Steering is 10.7 m. Beyond this distance, depth information becomes less accurate. Within this range, starting with the drill head approximately level, the following parameters apply to depth data:

- The maximum depth change is approximately 1.2 m.
- The maximum pitch change is approximately 14%.

For the most conservative Target Steering operation, assume the ideal drill path is a circular arc with a radius that accommodates the bend radius of most drill strings and products being installed. As shown in the diagram below, the feasible steering area is limited to the shaded region bounded by the two circular arcs.

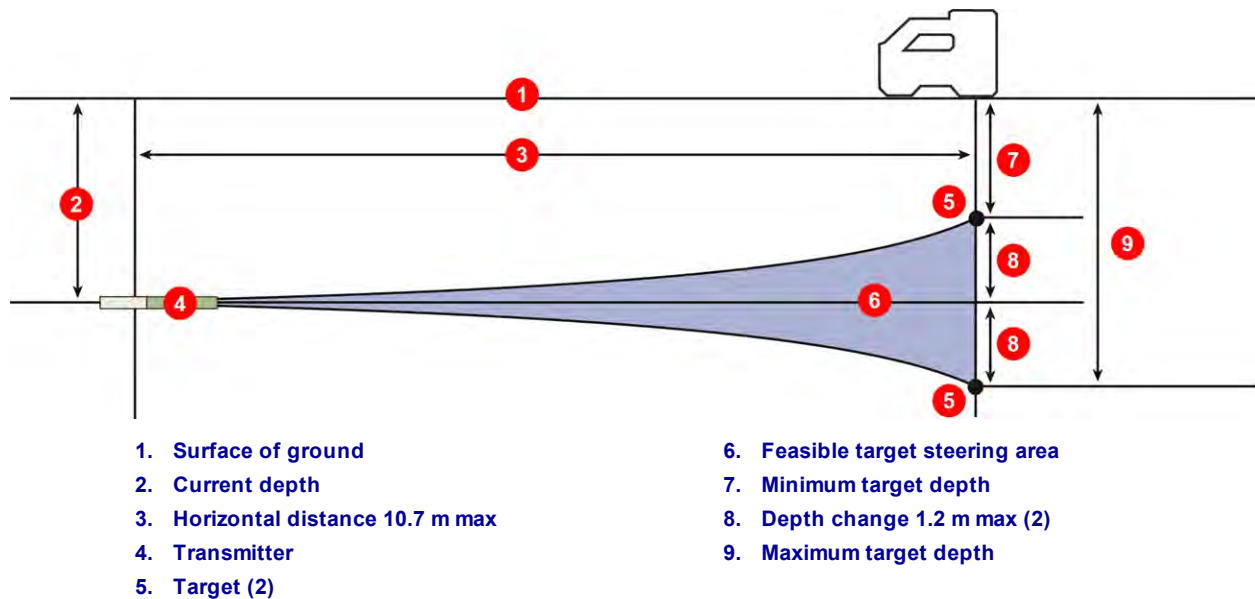

### Feasible Target Steering Area

The Target Steering procedure requires correct placement of the receiver at less than 10.7 m in front of the transmitter, on the bore path, with its back end (where the battery pack is inserted) facing the drill.

## Turning Target Steering On

The target depth is the depth at which you want the transmitter when it reaches the location under the receiver. To set the desired target depth on the receiver, toggle up at the Locate screen to open the Target Steering menu.

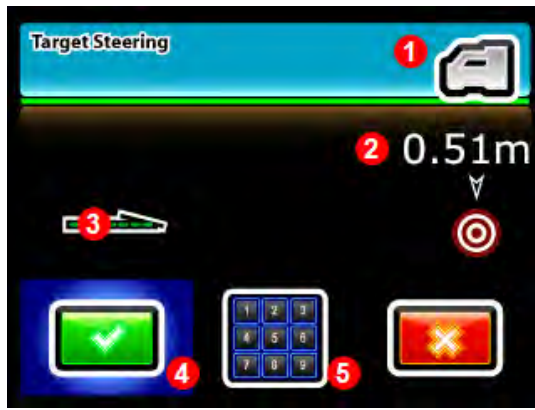

1. Receiver
2. Programmed target depth
3. Transmitter in ground pointing toward target below receiver
4. Turn on programmed target depth
5. Program new target depth

Target Steering Menu

The Target Steering menu displays either the last set target depth or the 1.5 ft. default value.

- To use the displayed value as the desired target depth, click the trigger.
- To enter a new target depth, select the keypad, enter the value in the appropriate units, and select **Enter** .

Any HAG setting in effect is ignored during Target Steering.

### Positioning the Receiver as the Target

Setting a target depth on the receiver activates target steering, and the Locate screen on the receiver now displays horizontal distance from transmitter to receiver. The remote display on the drill automatically changes to Target Steering mode.

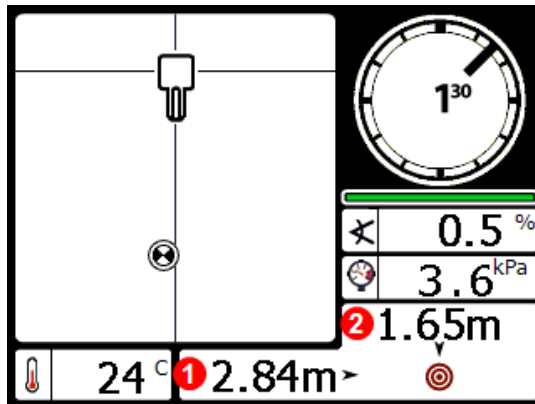

1. Horizontal distance from transmitter to receiver
2. Approximate transmitter depth

Target Steering Data on the Receiver (with pressure data)

Ensure that the location you would like to steer to beneath the receiver is feasible for the bend radius of the drill string and product being installed.

[Feasible Target Steering Area](#)

Page 55



Place the receiver on the intended drill path beyond the FLP but within 10.7 m of the transmitter with its back end (battery pack) facing the transmitter's current location. Position the receiver with the understanding that Target Steering is designed to ensure the transmitter is perpendicular to the rear of the receiver by the time the drill head reaches the target beneath the receiver.

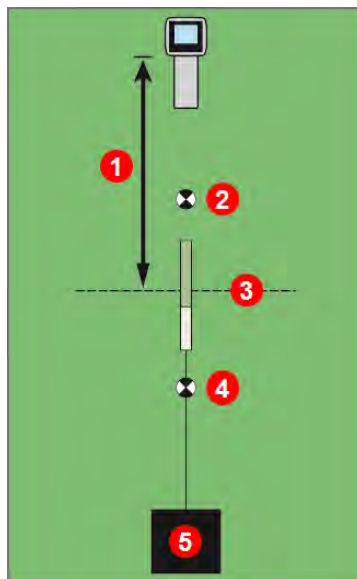

1. 10.7 m max
2. FLP
3. LL
4. RLP
5. Drill

### Positioning the Receiver for Target Steering



Depths are calculated based on the bottom of the receiver. The HAG value is still used in Target Steering mode when taking a depth at the Locate Line (LL) or Front Locate Point (FLP).

### Steering to the Target with the Remote Display

Refer to the operator's manual for your remote display for details on its Target Steering screen. Manuals are located on the flash drive that accompanied the equipment or online at [www.DigiTrak.com](http://www.DigiTrak.com).

### Target Steering in Interference Areas



Interference can cause inaccuracies in the measurement of depth and placement of the locating ball, and loss of the transmitter's pitch, roll, or heading.

In areas of passive and/or active interference, it may help to physically elevate the receiver above the ground. If raising the receiver above the ground, adjust the target depth to include the elevated height.

### Turn Target Steering Off

To turn off Target Steering on the receiver, toggle down from the Target Steering screen to return to the Locate screen. The receiver will now no longer act as a steering target. This also causes the remote display to exit Target Steering mode.

# Transmitter

A transmitter generates a magnetic field detected by the Falcon receiver. The transmitter and receiver must have matching regional designation numbers to communicate with each other and comply with local operating requirements. The transmitter's regional designation number is located inside the globe icon  near the serial number. The transmitter must be paired to the receiver prior to use.

The standard Falcon F5 wideband transmitter measures 38.1 cm long and 3.2 cm in diameter, provides pitch readings in as low as 0.1% or 0.1° increments at level, and displays roll in 24 clock positions (CP). The transmitter broadcasts in nine bands encompassing frequencies from 4.5 to 45.0 kHz.



1. Battery compartment
2. Front end cap with temp dot, index slot, and fluid ports

## Falcon F5 Wideband Transmitter with Fluid Pressure

Calibration is required prior to first-time use and before using a different transmitter, receiver, drill head, or transmitter band. Calibration is not necessary, however, when switching between bands on a transmitter that are already paired and calibrated.

[Calibration and AGR](#)

Page 14

A detailed pitch resolution table is located in [Appendix A: System Specifications](#).



### Can I use other DigiTrak transmitters with my Falcon?

No. The technology behind Falcon's use of multiple optimized frequencies requires a DigiTrak Falcon F5 wideband, DigiTrak Falcon F2 wideband, or DucTrak transmitter.

### Can I use DigiTrak transmitters rebuilt by other companies?

DCI recommends avoiding the use of "repaired" or "rebuilt" transmitters for any reason. Untrained technicians, poor quality of workmanship, and the re-use of stressed electronic components introduces unnecessary risk to your project that far outweighs any perceived short-term cost savings. DigiTrak Falcon transmitters incorporate recent advances in architecture and durability that provide an even longer expected lifetime under typical conditions.

## Batteries and Power On/Off

DigiTrak Falcon F5 wideband transmitters require two C-cell alkaline batteries or one DCI SuperCell™ lithium battery providing a maximum of 3.6 VDC. Alkaline batteries will last up to 20 hours, whereas a SuperCell battery will last up to 70 hours. A 19 in. transmitter requires use of a SuperCell battery due to its greater power requirements.



Never use damaged or non-DCI lithium batteries. Never use two C-cell lithium batteries providing a combined voltage above 3.6 VDC.

DCI SuperCell lithium batteries are manufactured to military specifications. The use of damaged or lower-quality lithium batteries may damage the transmitter and/or housing and will void the DCI warranty.

## Installing Batteries / Power On

DCI transmitters power on as soon as the batteries and battery cap are properly installed. To install the batteries:

1. Remove the battery cap from the transmitter using a large slotted screwdriver or coin and rotating counterclockwise.
2. Insert the battery or batteries into the transmitter with the positive terminals first. When using two C-cell batteries, include the battery contact spring that came with the transmitter as shown below:

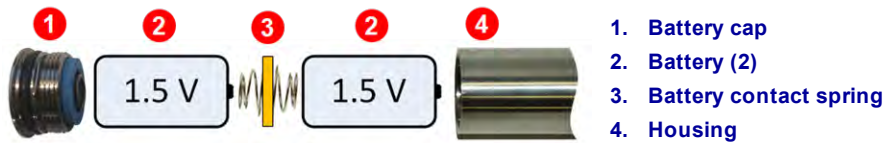

**C-Cell Batteries Installed with Battery Contact Spring**

Do NOT use the battery contact spring at either end of a single SuperCell™ battery.

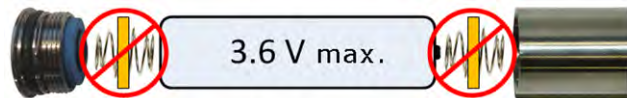

- Select the startup frequency of the transmitter by installing the batteries with the transmitter pointing either up or down:

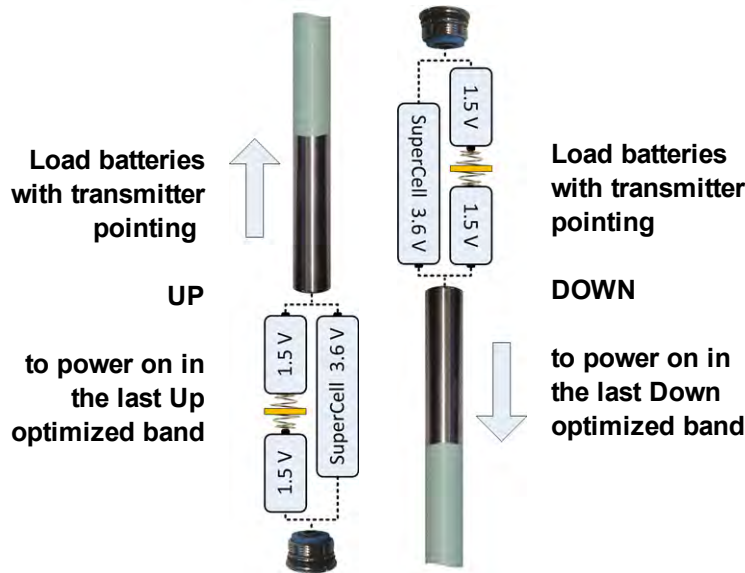

### Selecting the Startup Frequency of the Transmitter

To power on the transmitter in the last band used, install the batteries with the transmitter horizontal.

- Replace the battery cap and maintain orientation for at least 10 seconds.

 Starting the **Frequency Optimizer** will not change the transmitter's optimized frequency bands until the receiver and transmitter are paired. Once paired, the transmitter automatically begins using the new optimized frequency band. With two new bands, the system defaults to using the Down band first.

### Transmitter Battery Strength

The battery strength icon  at the bottom of the receiver's Depth screen indicates the battery life remaining for alkaline batteries.



Because the battery strength for a SuperCell battery will appear full until just before it is fully depleted, you must track its hours of use.

### Sleep Mode

All battery-powered DigiTrak transmitters go into sleep mode and stop transmitting to conserve battery power if they are stationary for longer than 15 minutes. To wake the transmitter, rotate the drill string a half turn; a transmitter will not awake if it lands on the same roll position at which it went to sleep.

A small amount of charge will continue to drain from the batteries while the transmitter is in sleep mode so it can monitor roll position. To conserve battery life, do not leave batteries in the transmitter when they can be easily removed. Always remove batteries when the transmitter is not being used to turn it off.



A transmitter will continue sending data for up to 10 seconds after the batteries are removed. If you have removed the batteries and intend to restart the transmitter in another frequency, wait until data has stopped displaying on the receiver before reinstalling the batteries.

## Transmitter Drill Head Requirements

For maximum transmitter range and battery life, the slots in the drill head must meet minimum length and width requirements and be correctly positioned. DCI's transmitters require three slots equally spaced around the circumference of the drill head for optimal signal emission and maximum battery life. Measure slot lengths on the *inside* of the drill head; slots must be at least 1.6 mm (1/16 in.) wide. DCI transmitters fit standard housings but may require a battery cap adapter in some cases.

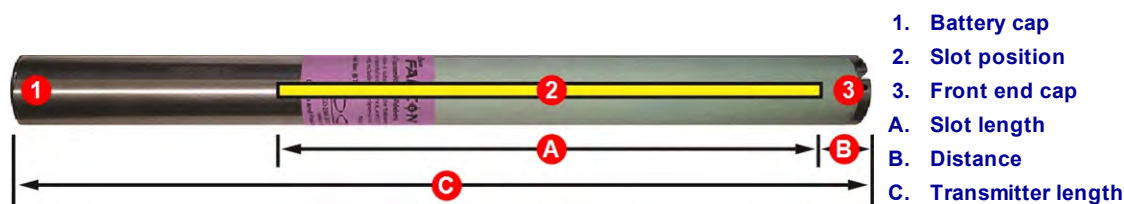

	A Minimum	B Maximum*	C
Falcon F5 Wideband	22.9 cm*	2.5 cm	38.1 cm
Falcon F5 19 in. Wideband	33.0 cm*	2.5 cm	48.3 cm

\* Ideal measurement. The DCI standard slot length of 21.6 cm (A) and distance of 5.1 cm (B) remain acceptable.

A transmitter must fit snugly in its drill head. It may be necessary to wrap the transmitter with tape or O-rings and/or use a drill head adapter for larger drill heads. Contact DCI Customer Service for more information.

The index slot in the front end cap of the transmitter should fit onto the anti-roll pin (key) in the drill head for proper alignment. Use roll offset if the transmitter's 12:00 position does not match that of the drill head.



[Roll Offset Menu](#)

Page 22

Use only the battery cap that accompanied the Falcon transmitter; other battery caps may look similar but crush the batteries or make the transmitter too long to fit in a standard housing.

## Temperature Status and Overheat Indicator

All DigiTrak transmitters are equipped with an internal digital thermometer. The temperature displays on the bottom right of the receiver and remote display screens next to the transmitter temperature symbol . Normal drilling temperatures range from 16 to 40° C. Suspend drilling when temperatures exceed 36° C to permit cooling.

A small triangle beside the temperature icon indicates whether the temperature is trending up  or down  since the last reading.



Because the digital thermometer is inside the transmitter, temperature increases due to external drilling conditions will take time to transfer to the transmitter. Resolve increases in temperature quickly to avoid irreversible damage.

If the temperature reaches 48° C, the thermometer icon will change to show that the transmitter is becoming dangerously hot . The transmitter must be allowed to cool immediately or it will be damaged.

To cool the transmitter, stop drilling and retract the drill one meter and/or add more drilling fluid.

## Transmitter Temperature Warning Tones

The Falcon receiver and remote display emit the following audible tones to indicate increases in the transmitter temperature:

Icon	Temperature	Warning Tones
	Below 16° C	None
	16–36° C	Double-beep sequence (beep-beep) for every 4° C increase in temperature.
	40–44° C	Two double-beep sequences (beep-beep, beep-beep) for every 4° C increase in temperature. Action is required to cool the transmitter.
	48–56° C	Three double-beep sequences (beep-beep, beep-beep, beep-beep) for every 4° C increase in temperature. Cooling is critical to avoid irreversible damage.
	Above 60° C	Three double-beep sequences every 5 seconds on the remote display, and every 20 seconds on the receiver. This warning signifies dangerous drilling conditions; irreversible damage may have already been done to the transmitter.
	104° C	None: transmitter overheat indicator (temp dot) turns black.

## Transmitter Overheat Indicator (Temp Dot)

Each transmitter has a temperature overheat indicator (temp dot) on the front end cap. The temp dot has an outer yellow ring with a 3 mm (1/8 in.) white dot in the center.

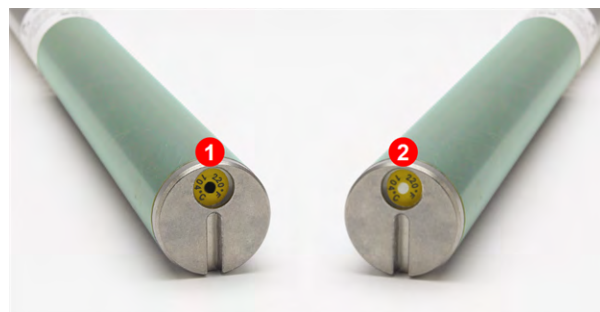

1. Black temp dot voids warranty
2. Normal temp dot

### Transmitter Temp Dot

If the temp dot changes to silver or gray, the transmitter has been exposed to heat but not in excess of specifications. If the temp dot is black, the transmitter has been exposed to excessive temperatures and can no longer be used. The DCI warranty does not cover any transmitter that has been overheated (black dot) or had its temp dot removed.

Avoid transmitter overheating by practicing proper drilling techniques. Abrasive soils, clogged jets, inadequate mud flow, and improperly mixed mud all contribute significantly to the overheating of a transmitter.

The Falcon transmitter stores the maximum temperature, which you can view using the Transmitter Info function. Note that the external temp dot can reach 104° C and turn black before the *internal* temperature reaches 104° C.

[Transmitter Information](#)

Page 28

## Changing Frequency Bands

With the receiver at the Locate screen, hold toggle right to open the Band Selection menu, where you can switch between the Up and Down frequency bands and enable or disable fluid pressure monitoring.

[Band Selection](#)  
Page 28

Use these procedures to switch between the two optimized frequency bands, such as when performing an [interference check](#) (page 40), or an [AGR test](#) (page 17) in both bands with the transmitter in the drill head prior to drilling.

[Installing Batteries /  
Power On](#)  
Page 59

### Above Ground (Pre-Bore) Tilt Method

Do not roll the transmitter more than two clock positions (CP) during this procedure.

1. Place the transmitter on an approximately level surface ( $0\pm 10^\circ$ ) for at least five seconds with the receiver at the Locate screen and transmitter data being displayed.
2. Tilt the transmitter up at approximately  $65^\circ$  (over 100%, or nearly vertical).
3. Hold the transmitter steady for 10–18 seconds.
4. Return the transmitter to level within 10 seconds.
5. After 10–18 seconds, all transmitter data disappears from the receiver's screen, indicating the transmitter frequency has changed.
6. Select the new frequency band in the receiver's Band Selection menu. The new band displays at the top of the Main menu. It may take up to 30 seconds for the transmitter to begin sending data on the new frequency; return to the Locate screen and verify that transmitter data appears on the display.



[Band Selection  
Menu](#)  
Page 28

### Below Ground (Mid-Bore) Roll Methods

Switching between bands on the Falcon F5 transmitter may provide better data results while drilling in a section of the bore with a high level of interference. Use these methods to switch between transmitter frequency bands mid-bore. Practice these roll methods *before* sending the drill head below ground.

#### Frequency Change, 10-2-7

1. Ensure roll offset is disabled and transmitter roll data is displayed on the receiver.
2. Position the transmitter at 10:00 ( $\pm 1$  clock position, or CP) for 10–18 seconds.
3. Roll the transmitter clockwise to its 2:00 position ( $\pm 1$  CP) within 10 seconds and remain there for 10–18 seconds.
4. Roll the transmitter clockwise to its 7:00 position ( $\pm 1$  CP) within 10 seconds.
5. When transmitter data disappears from the receiver, the transmitter frequency has changed. This will take approximately 10–18 seconds.
6. Select the new frequency band in the receiver's Band Selection menu. The new band displays at the top of the Main menu. It may take up to 30 seconds for the transmitter to begin sending data on the new frequency; return to the Locate screen and verify that transmitter data appears on the display.
7. Re-enable roll offset, if applicable.

[Roll Offset Menu](#)  
Page 22

[Band Selection  
Menu](#)  
Page 28

**Frequency Change, Repeating Roll Sequence (RRS3)**

1. Remain at any clock position (CP) for at least 40 seconds to clear all timers.
2. Make a reference mark on the drill string.
3. Complete one full clockwise rotation ( $\pm 2$  CP) of the reference mark within 0.5–30 sec., then wait 10–20 seconds.
4. Repeat step 3 two more times, for a total of three rotations (RRS3).
5. After the third rotation, leave the drill string at rest for a total of 60 seconds, after which the transmitter changes frequency.
6. Select the new frequency band in the receiver's Band Selection menu. The new band displays at the top of the Main menu. It may take up to 30 seconds for the transmitter to begin sending data on the new frequency; return to the Locate screen and verify that transmitter data appears on the display.

[Band Selection](#)[Menu](#)

Page 28

If any rotation is not completed within the prescribed time, or if any rotation continues for more than one full revolution, the transmitter frequency change is canceled.









A warning symbol  in the roll indicator after changing bands on the receiver means the transmitter has not yet been [calibrated](#) in this band. While locate positions and roll/pitch data will be correct, depth readings will be incorrect.



# Appendix A: System Specifications

## Power Requirements

Device (Model Number)	Operational Voltage	Operational Current
DigiTrak Falcon F5 Receiver (FAR5)	14.4 V 	390 mA max
DigiTrak F Series Battery Charger (FBC)	Input 10–28 V  Output 19.2 V 	5.0 A max 1.8 A max
DigiTrak F Series Lithium-Ion Battery Pack (FBP)	14.4 V  (nominal)	4.5 Ah 65 Wh max
DigiTrak Transmitter (BTW, BTP, BTPL)	1.2–4.2 V 	1.75 A max
DigiTrak Transmitter (FT2S)	1.2–4.2 V 	0.4 A max

## Environmental Requirements

Device	Relative Humidity	Operating Temperature
DigiTrak Falcon F5 Receiver (FAR5) with Lithium-Ion Battery Pack	<90%	-20 to 60° C
DigiTrak Aurora Remote Display (AF8/AF10)	<90%	-20 to 60° C
DigiTrak Transmitter (BTW, BTP, BTPL)	<100%	-20 to 104° C
DigiTrak Transmitter (FT2S)	<100%	-20 to 82° C
DigiTrak F Series Battery Charger (FBC)	<99% for 0–10° C <95% for 10–35° C	0 to 35° C
DigiTrak F Series Lithium-Ion Battery Pack (FBP)	<99% for <10° C <95% for 10–35° C <75% for 35–60° C	-20 to 60° C

System working altitude: up to 2000 m.

## Storage and Shipping Requirements

### Temperature

Storage and transportation temperature must remain within -40 to 65° C.

### Packaging

Ship in original carrying case or packaging of sufficient durability to prevent mechanical shock to equipment during transportation.

Approved for transportation by vehicle, boat, and aircraft.

SuperCell batteries are regulated UN3090 lithium metal batteries and F Series FBP batteries are regulated UN3480 and UN3481 lithium-ion batteries. Lithium batteries are considered Class 9 Miscellaneous Dangerous Goods under International Air Transportation Association (IATA) regulations; IATA regulation and Ground Transportation regulations 49 CFR 172 and 174 apply. These batteries must be packaged and shipped by trained and certified personnel only. Never ship damaged batteries.

## Equipment and Battery Disposal



This symbol on equipment indicates that the equipment must not be disposed of with your other household waste. Instead, it is your responsibility to dispose of such equipment at a designated collection point for the recycling of batteries or electrical and electronic equipment. If the equipment contains a banned substance, the label will show the pollutant (Cd = Cadmium; Hg = Mercury; Pb = Lead) near this symbol. Before recycling, ensure batteries are discharged or the terminals are covered with adhesive tape to prevent shorting. The separate collection and recycling of your waste equipment at the time of disposal will help conserve natural resources and ensure it is recycled in a manner that protects human health and the environment. For more information about where you can drop off your waste equipment for recycling, please contact your local city office, your household waste disposal service, or the shop where you purchased the equipment.









## Transmitter Pitch Resolution

Transmitter pitch resolution decreases with increased grade.

±% Grade	± Degrees Grade	% Resolution
0 – 3%	0 – 1.7°	0.1%
3 – 9%	1.7 – 5.1°	0.2%
9 – 30%	5.1 – 16.7°	0.5%
30 – 50%	16.7 – 26.6°	2.0%
50 – 90%	26.6 – 42.0°	5.0%

## Appendix B: Receiver Screen Symbols

Symbol	Description
	<b>Attenuated Signal</b> – Indicates signal attenuation is in effect due to the presence of excessive interference, or when locating within 1 m of the transmitter. The receiver automatically attenuates the transmitter signal when locating at shallow depths to reduce excessive signal strength. The <b>A</b> displays at the bottom left of the <a href="#">frequency optimizer results</a> (page 25) , or at the top right of the <a href="#">roll indicator</a> (page 36) on the locate screen, or beneath the Calibration Failure icon. Attenuation while locating in close proximity to the transmitter is normal; attenuation during calibration or frequency optimization is a warning to relocate to a location with less interference. The receiver will not calibrate when the A icon and signal strength are flashing red, indicating the presence of extreme interference. <i>Page 14</i>
	<b>Band Up or Down</b> – Indicates whether the receiver is currently using the Up or Down optimized band. Located in the title bar of the Locate screen. <i>Page 13</i>
	<b>Calibration Signal High</b> – Displays after a failed calibration, often because the transmitter is too close to the receiver. <i>Page 16</i>
	<b>Calibration Signal Low</b> – Displays after a failed calibration, often because the transmitter is not powered on or is on a different (Up or Down) frequency band than the receiver. <i>Page 16</i>
	<b>Calibration Attenuation Error</b> – Displays after a failed calibration. If attenuation is in effect due to only moderate interference, the system will still calibrate; however, it is best practice to relocate to a quieter location where attenuation is not required. If the signal strength and <b>A</b> attenuation icon on the locate screen are flashing red, this indicates extreme interference, and a calibration will fail. <i>Page 15</i>
	<b>Globe Icon</b> – Shown on the receiver startup screen, the number inside (shown blank here) identifies the regional designation, which must match that on the transmitter battery compartment. <i>Page 6</i>
	<b>Ground Level</b> – Represents the ground for the HAG function, depth readings, and the in-ground calibration procedure. <i>Page 37</i>
	<b>Locate Line</b> – The locate line (LL) always displays perpendicular to the transmitter. The locate line (LL) is found between the front and rear locate points only after a reference lock (see below) has been obtained. May also include the transmitter yaw angle in degrees. <i>Page 37</i>
	<b>Locating Ball/Target</b> – Represents the front and rear locate points (FLP and RLP). When the locate line appears, the locating ball will become a solid circle (ball) representing the approximate locate point. <i>Page 36</i>
	<b>Locating Icon</b> (the receiver) – Represents a bird's-eye view of the receiver. The square at the top of this icon is referred to as the “box” in the terms <i>Ball-in-the-Box™</i> and <i>Line-in-the-Box</i> locating. <i>Page 36</i>
	<b>Max mode</b> – Max mode begins when the trigger is held longer that five seconds during a depth reading. <i>Page 37</i>
	<b>Max Mode Timer</b> – Provides a visual indication that Max mode is active (trigger held). Replaces the roll/pitch update meter. It will remain red if no stable signal can be found. <i>Page 37</i>
	<b>Pitch Assumed Zero</b> – Indicates that since no pitch data is currently available, the pitch is assumed to be zero for depth, predicted depth, and AGR calculations. <i>Page 37</i>
	<b>Pressure</b> – When using a fluid pressure transmitter, the number next to this icon on the Locate screen indicates the pressure reading. If the pressure reaches an over-limit condition (from 689–1724 kPa), the value will appear red. When the pressure reaches the overload condition (over 1724 kPa), the value will display as “+OL”. <i>Page 23</i>
	<b>Receiver Battery Strength</b> – Shows the remaining battery life of the receiver. Appears above the main menu. When battery life is low, the icon will flash on the Locate screen. <i>Page 13</i>

Symbol	Description
	<b>Receiver Icon</b> – Indicates the position of the receiver relative to the ground for the HAG function, depth readings, in-ground calibration, and the Target Steering function. <i>Page 37</i>
R	<b>Reference Lock</b> – Indicates a reference signal has been obtained for displaying the locate line. Displays at the top of the Locate screen. <i>Page 46</i>
RO	<b>Roll Offset</b> – Indicates roll offset is enabled. Displays at the bottom left of the roll indicator. <i>Page 22</i>
	<b>Roll/Pitch Update Meter</b> – Shows the quality of data reception from the transmitter (specifically, data rate). A full bar is the best signal. A shorter bar indicates the receiver is in an area of interference or you are reaching the range limit of the transmitter, relative to interference. <i>Page 36</i>
	<b>Telemetry Channel</b> – The channel used to communicate with the remote display on the drill rig. Select whichever channel offers the best performance. Select channel 0 to turn telemetry off. <i>Page 21</i>
	<b>Transmitter Battery Strength/Drill Head</b> – Depicts the remaining battery life of the transmitter when alkaline batteries are used. Also represents the position of the drill head relative to the receiver in the Depth screen. <i>Page 37</i>
	<b>Transmitter Pitch</b> – The number next to this icon on the Locate screen is the transmitter pitch angle. It is also the Settings menu icon for changing the pitch angle units between percent and degrees. <i>Page 36</i>
	<b>Transmitter Roll Indicator</b> – Shows the transmitter’s roll position. The roll value appears in the center of the clock. When roll offset is enabled, the letters “RO” appear at the bottom left and the indicator becomes a circle. <i>Page 36</i>
	<b>Transmitter Signal Strength</b> – The number next to this icon on the Locate screen is the transmitter signal strength. Maximum signal strength is about 1200. <i>Page 36</i>
	<b>Transmitter Temperature</b> – The number next to this icon shows the transmitter temperature. An up or down arrow indicates the trend from the last reading. The icon will display steam and flash when the transmitter becomes dangerously hot, indicating the transmitter must be cooled immediately or it will be damaged. <i>Page 61</i>
	<b>Warning</b> – This error symbol indicates a failure in a self-test or a need to calibrate the receiver to one or both transmitter bands. <i>Page 36</i>

## Appendix C: Projected Depth Versus Actual Depth and the Fore/Aft Offset

### What Happens When the Transmitter Is Steep and Deep

The signal field emitted by the transmitter consists of a set of elliptical signals, or “flux lines”. The flux lines indicate the position of the transmitter. When the transmitter is level with respect to the ground, the locate line (LL) is directly over the transmitter, the depth displayed on the receiver is the actual depth, and the locate points (FLP and RLP) are at equal distances from the transmitter. The location of the LL is found at the intersection of the ground and the horizontal component of the flux field; the FLP and RLP are found where the vertical components of the flux field intersect with the ground. Some of the horizontal and vertical components are identified below by short yellow lines.

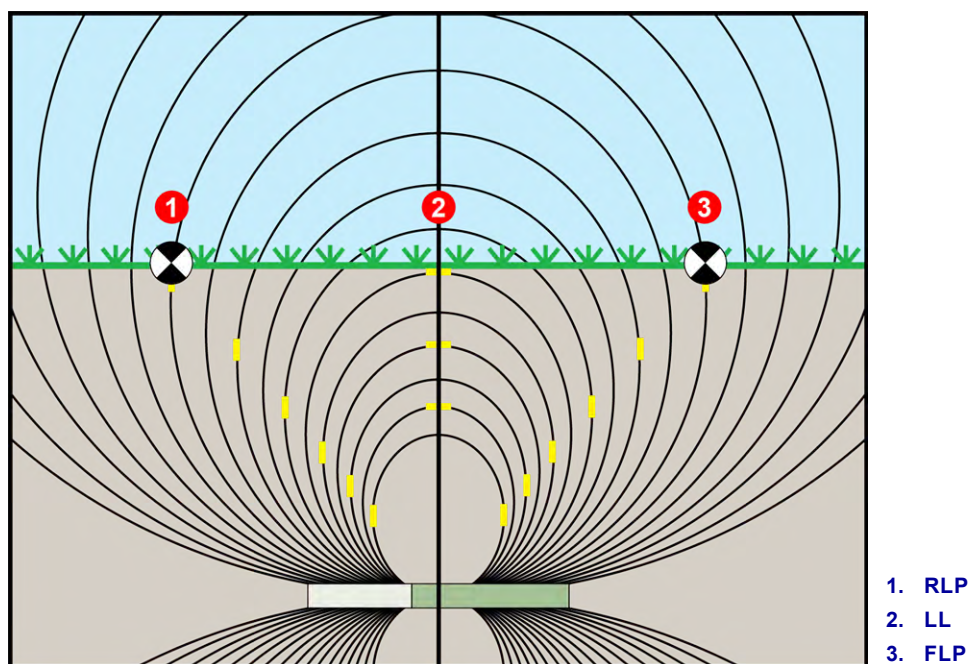

**Side View of Flux Field and Geometry of FLP, RLP, and LL**

Due to the shape of the transmitter’s signal field, when it is at a pitch greater than  $\pm 10\%$  ( $\pm 5.7^\circ$ ) and/or a depth of 4.6 m or more, the position of the locate line will be some distance ahead of or behind the transmitter’s actual position. In this case, the depth displayed on the receiver becomes what is called the projected depth. The transmitter’s distance ahead of or behind the locate line is called the fore/aft offset.

The projected depth and fore/aft offset must be accounted for when the transmitter is steep and/or deep. See [Table C1: Determining Actual Depth from Displayed \(Projected\) Depth and Pitch](#) and [Table C2: Determining Fore/Aft Offset from Displayed \(Projected\) Depth and Pitch](#) to determine the actual depth and fore/aft offset when you know the displayed (projected) depth and pitch of the transmitter.

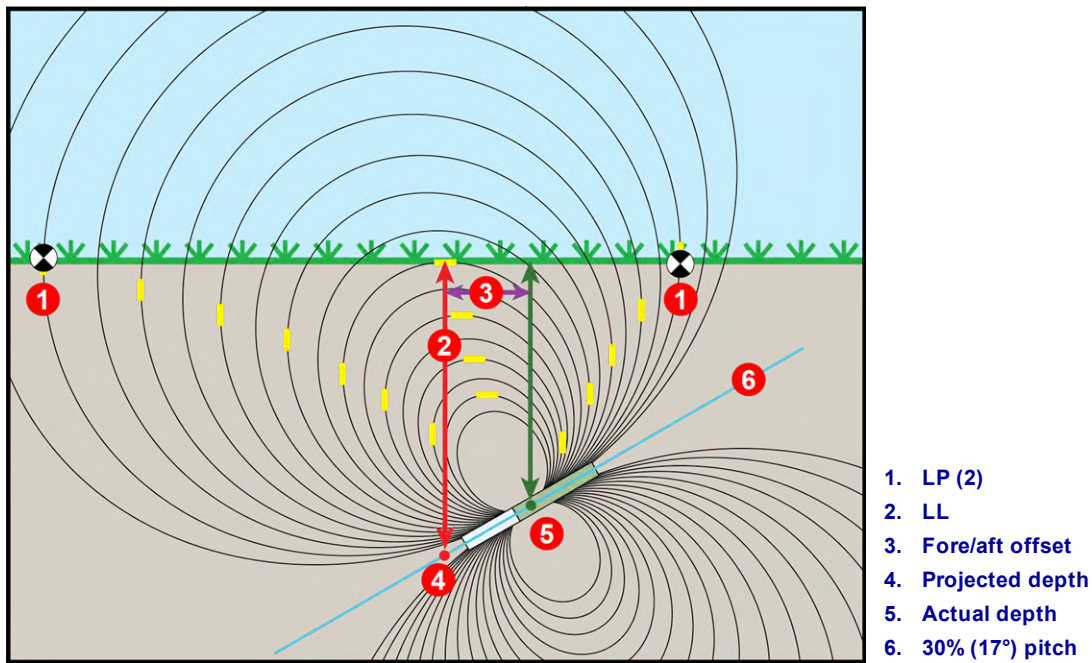

**Side View of Actual Depth due to Fore/Aft Offset When Steep and Deep**

The above figure shows a transmitter positioned in a drill string that is drilling at either a positive or a negative pitch—the pitch is positive if you are drilling left to right, negative if you are drilling right to left. The transmitter's signal field is also pitched at the same angle as the transmitter. The locate line (LL), which is where the depth measurement is taken, is the horizontal component of the transmitter's signal field flux lines. That is, the LL is found where the flux lines are horizontal, illustrated by short horizontal yellow lines above.

The locate points (FLP and RLP) are also shown above. These points are located at the vertical components of the signal field illustrated by short vertical yellow lines above. Note how the locate points are not the same distance from the LL when the transmitter is pitched. Again, this situation requires compensation for the projected depth and the fore/aft offset.

Using the following tables to find:

- **actual depth** based on the receiver's depth reading (projected depth) and the transmitter pitch – [Table C1](#)
- **fore/aft offset** based on the receiver's depth reading (projected depth) and the transmitter pitch – [Table C2](#)
- **projected depth** that you will see on the receiver during drilling if you know the required depth (actual depth) of your installation – [Table C3](#)
- **conversion factors** for determining the projected depth from the actual depth, or the actual depth from the projected depth at various transmitter pitches – [Table C4](#)

These "steep and deep" calculations for projected depth are important when using a bore plan that has specified target depths on steeper and deeper bores.

Pitch → Displayed Depth ↓	±10% (5.7°)	±20% (11°)	±30% (17°)	±40% (22°)	±50% (27°)	±60% (31°)	±75% (37°)	±90% (42°)	±100% (45°)
1.52 m	1.52 m	1.50 m	1.45 m	1.37 m	1.32 m	1.27 m	1.17 m	1.07 m	0.76 m
3.05 m	3.02 m	2.97 m	2.87 m	2.77 m	2.64 m	2.51 m	2.31 m	2.13 m	1.52 m
4.57 m	4.55 m	4.47 m	4.32 m	4.14 m	3.96 m	3.78 m	3.48 m	3.20 m	2.29 m
6.10 m	6.07 m	5.94 m	5.74 m	5.51 m	5.28 m	5.03 m	4.65 m	4.27 m	3.05 m
7.62 m	7.59 m	7.44 m	7.19 m	6.91 m	6.60 m	6.30 m	5.79 m	5.33 m	3.81 m
9.14 m	9.09 m	8.92 m	8.61 m	8.28 m	7.92 m	7.54 m	6.96 m	6.40 m	4.57 m
10.67 m	10.62 m	10.41 m	10.08 m	9.65 m	9.25 m	8.81 m	8.13 m	7.47 m	5.33 m
12.19 m	12.14 m	11.89 m	11.51 m	11.02 m	10.57 m	10.06 m	9.27 m	8.53 m	6.10 m
13.72 m	13.64 m	13.39 m	12.93 m	12.42 m	11.89 m	11.33 m	10.44 m	9.63 m	6.86 m
15.24 m	15.16 m	14.86 m	14.38 m	13.79 m	13.21 m	12.57 m	11.61 m	10.69 m	7.62 m

**Table C1: Determining Actual Depth from Displayed (Projected) Depth and Pitch**

Use the projected/displayed depth values in the first column and transmitter pitches in the first row to find actual depth.

Pitch → Displayed Depth ↓	±10% (5.7°)	±20% (11°)	±30% (17°)	±40% (22°)	±50% (27°)	±60% (31°)	±75% (37°)	±90% (42°)	±100% (45°)
1.52 m	0.10 m	0.20 m	0.28 m	0.38 m	0.48 m	0.53 m	0.64 m	0.74 m	0.76 m
3.05 m	0.20 m	0.41 m	0.58 m	0.76 m	0.94 m	1.07 m	1.27 m	1.45 m	1.52 m
4.57 m	0.30 m	0.61 m	0.89 m	1.14 m	1.40 m	1.63 m	1.91 m	2.16 m	2.29 m
6.10 m	0.41 m	0.79 m	1.17 m	1.52 m	1.85 m	2.16 m	2.54 m	2.90 m	3.05 m
7.62 m	0.51 m	0.99 m	1.47 m	1.91 m	2.31 m	2.69 m	3.18 m	3.61 m	3.81 m
9.14 m	0.61 m	1.19 m	1.78 m	2.29 m	2.79 m	3.23 m	3.81 m	4.32 m	4.57 m
10.67 m	0.71 m	1.40 m	2.06 m	2.67 m	3.25 m	3.78 m	4.47 m	5.05 m	5.33 m
12.19 m	0.81 m	0.69 m	2.36 m	3.05 m	3.71 m	4.32 m	5.11 m	5.77 m	6.10 m
13.72 m	0.91 m	1.80 m	2.64 m	3.45 m	4.17 m	4.85 m	5.74 m	6.48 m	6.86 m
15.24 m	1.02 m	2.01 m	2.84 m	3.84 m	4.65 m	5.38 m	6.38 m	7.21 m	7.62 m

**Table C2: Determining Fore/Aft Offset from Displayed (Projected) Depth and Pitch**

Use the projected/displayed depth values in the first column and transmitter pitches in the first row to find fore/aft Max mode timer offset values.

Pitch → Displayed Depth ↓	±10% (5.7°)	±20% (11°)	±30% (17°)	±40% (22°)	±50% (27°)	±60% (31°)	±75% (37°)	±90% (42°)	±100% (45°)
1.52 m	1.52 m	1.57 m	1.60 m	1.68 m	1.73 m	1.80 m	1.91 m	1.98 m	2.29 m
3.05 m	3.07 m	3.12 m	3.23 m	3.33 m	3.45 m	3.58 m	3.78 m	3.96 m	4.57 m
4.57 m	4.60 m	4.70 m	4.83 m	5.00 m	5.18 m	5.38 m	5.66 m	5.94 m	6.86 m
6.10 m	6.12 m	6.25 m	6.45 m	6.68 m	6.91 m	7.16 m	7.54 m	7.92 m	9.14 m
7.62 m	7.67 m	7.82 m	8.05 m	8.36 m	8.64 m	8.97 m	9.45 m	9.91 m	11.43 m
9.14 m	9.19 m	9.37 m	9.68 m	10.01 m	10.36 m	10.74 m	11.33 m	11.89 m	13.72 m
10.67 m	10.72 m	10.95 m	11.28 m	11.68 m	11.18 m	12.55 m	13.21 m	13.87 m	16.00 m
12.19 m	12.24 m	12.50 m	12.88 m	13.36 m	13.82 m	14.33 m	15.11 m	15.85 m	18.29 m
13.72 m	13.79 m	14.07 m	14.50 m	15.01 m	15.54 m	15.90 m	16.99 m	17.83 m	11.43 m
15.24 m	15.32 m	15.62 m	16.10 m	16.69 m	17.27 m	17.91 m	18.87 m	19.79 m	22.86 m

**Table C3: Determining Projected Depth from Actual Depth and Pitch**

Use the actual depth values in the first column and transmitter pitches in the first row to find projected depth values.

Pitch →	±10% (5.7°)	±20% (11°)	±30% (17°)	±40% (22°)	±50% (27°)	±60% (31°)	±75% (37°)	±90% (42°)
From Actual to Projected Depth	1.005	1.025	1.06	1.105	1.155	1.212	1.314	1.426
From Projected to Actual Depth	0.995	0.975	0.943	0.905	0.866	0.825	0.761	0.701

**Table C4: Conversion Factors for Calculating Exact Projected Depth or Actual Depth**

Table C4 helps calculate the exact projected depth reading as well as the actual depth using a multiplier (conversion factor) at different transmitter pitches.

For example, if you have a required (actual) depth of 7.32 m and want the receiver's projected depth reading at a 30% (17°) pitch, use the first row of conversion factors to select the corresponding value for a pitch of 30%, which is 1.06. Multiply this value by the required depth of 24. The result, 7.75 m, is what the receiver's projected depth reading should be at the locate line.

Using the projected depth displayed on the receiver, you can calculate the actual depth of the transmitter using the second row of conversion factors. For example, if your pitch is 30% and your projected depth reading is 7.32 m, multiply depth 24 by conversion factor 0.943. The result, 6.90 m, is the actual depth of the transmitter.



## Appendix D: Calculating Depth Based on Distance Between FLP and RLP

If you know the transmitter pitch, the positions of the front locate point (FLP) and the rear locate point (RLP), and if the ground surface is level, you can still estimate the transmitter depth even if the depth information displayed on the receiver becomes unreliable.

To estimate the transmitter depth, first measure the distance between the FLP and the RLP. The pitch of the transmitter must also be reliably known. Using the Depth Estimation Table below, find the divider that most closely corresponds to the transmitter pitch. Then use the following formula to estimate the depth:

$$\text{Depth} = \text{Distance between FLP and RLP} / \text{Divider}$$

For example, if the transmitter pitch is 34% (or 18.8°) then the corresponding divider value (from the table) is 1.50. In this example, the distance between the FLP and the RLP is 3.5 m. The depth would be:

$$\text{Depth} = 3.5 \text{ m} / 1.50 = 2.34 \text{ m}$$

Pitch ( % / ° )	Divider	Pitch ( % / ° )	Divider	Pitch ( % / ° )	Divider
0 / 0.0	1.41	34 / 18.8	1.50	68 / 34.2	1.74
2 / 1.1	1.41	36 / 19.8	1.51	70 / 35.0	1.76
4 / 2.3	1.42	38 / 20.8	1.52	72 / 35.8	1.78
6 / 3.4	1.42	40 / 21.8	1.54	74 / 36.5	1.80
8 / 4.6	1.42	42 / 22.8	1.55	76 / 37.2	1.82
10 / 5.7	1.42	44 / 23.7	1.56	78 / 38.0	1.84
12 / 6.8	1.43	46 / 24.7	1.57	80 / 38.7	1.85
14 / 8.0	1.43	48 / 25.6	1.59	82 / 39.4	1.87
16 / 9.1	1.43	50 / 26.6	1.60	84 / 40.0	1.89
18 / 10.2	1.44	52 / 27.5	1.62	86 / 40.7	1.91
20 / 11.3	1.45	54 / 28.4	1.63	88 / 41.3	1.93
22 / 11.9	1.45	56 / 29.2	1.64	90 / 42.0	1.96
24 / 13.5	1.46	58 / 30.1	1.66	92 / 42.6	1.98
26 / 14.6	1.47	60 / 31.0	1.68	94 / 43.2	2.00
28 / 15.6	1.48	62 / 31.8	1.69	96 / 43.8	2.02
30 / 16.7	1.48	64 / 32.6	1.71	98 / 44.4	2.04
32 / 17.7	1.49	66 / 33.4	1.73	100 / 45.0	2.06

**Depth Estimation Table**

## Appendix E: Reference Tables

---

### Depth Increase in cm per 3-m Rod

Percent	Depth Increase	Percent	Depth Increase
1	2 cm	28	81 cm
2	5 cm	29	84 cm
3	10 cm	30	86 cm
4	13 cm	31	91 cm
5	15 cm	32	94 cm
6	18 cm	33	97 cm
7	20 cm	34	99 cm
8	25 cm	35	102 cm
9	28 cm	36	104 cm
10	30 cm	37	107 cm
11	33 cm	38	109 cm
12	36 cm	39	112 cm
13	38 cm	40	114 cm
14	43 cm	41	117 cm
15	46 cm	42	117 cm
16	48 cm	43	119 cm
17	51 cm	44	122 cm
18	53 cm	45	124 cm
19	56 cm	46	127 cm
20	61 cm	47	130 cm
21	64 cm	50	137 cm
22	66 cm	55	147 cm
23	69 cm	60	157 cm
24	71 cm	70	175 cm
25	74 cm	80	191 cm
26	76 cm	90	203 cm
27	79 cm	100	216 cm

## Depth Increase in cm per 4.6-m Rod

Percent	Depth Increase	Percent	Depth Increase
1	5 cm	28	124 cm
2	10 cm	29	127 cm
3	13 cm	30	132 cm
4	18 cm	31	135 cm
5	23 cm	32	140 cm
6	28 cm	33	142 cm
7	33 cm	34	147 cm
8	36 cm	35	150 cm
9	41 cm	36	155 cm
10	46 cm	37	157 cm
11	51 cm	38	163 cm
12	53 cm	39	165 cm
13	58 cm	40	170 cm
14	64 cm	41	173 cm
15	69 cm	42	178 cm
16	71 cm	43	180 cm
17	76 cm	44	183 cm
18	81 cm	45	188 cm
19	86 cm	46	191 cm
20	89 cm	47	196 cm
21	94 cm	50	203 cm
22	99 cm	55	221 cm
23	102 cm	60	236 cm
24	107 cm	70	262 cm
25	112 cm	80	284 cm
26	114 cm	90	305 cm
27	119 cm	100	323 cm

# Limited Warranty

Digital Control Incorporated ("DCI") warrants that, when shipped from DCI, each DCI product (other than software products) will conform to DCI's current published specifications in existence at the time of shipment and will be free, for the warranty period ("Warranty Period") specified below, from material defects in materials and workmanship. In addition, DCI warrants that each DCI software product will perform in substantial accordance with the specifications set forth in the documentation for such software for the Warranty Period specified below. The following limited warranty ("Limited Warranty") is made solely to and for the benefit of the first end-user ("User") purchasing the DCI product from either DCI or a dealer expressly authorized by DCI to sell DCI products ("Authorized DCI Dealer") and is not assignable or transferable.

The foregoing Limited Warranty is subject to the following terms, conditions and limitations:

1. A Warranty Period of twelve (12) months shall apply to the following new DCI products: receivers/locators, remote displays, battery chargers and rechargeable batteries, and software programs and applications. A Warranty Period of ninety (90) days shall apply to all other new DCI products, including transmitters and accessories. A Warranty Period of ninety (90) days shall also apply to services provided by DCI, including testing, servicing, and repairing an out-of-warranty DCI product. The Warranty Period shall begin from the later of: (i) the date of shipment of the DCI product from DCI, or (ii) the date of shipment (or other delivery) of the DCI product from an Authorized DCI Dealer to User.
2. If a DCI product (excluding software products) does not perform as warranted during the Warranty Period, DCI will inspect the product and if DCI determines such product to be defective, DCI will, at its sole option and discretion, either repair or replace the product. If a software product does not perform as warranted during the Warranty Period, DCI will, at its sole option and discretion, either bring the defective software into material compliance with the specifications for such software or refund the purchase price paid for the defective software. THE FOREGOING ARE USER'S SOLE AND EXCLUSIVE REMEDIES FOR BREACH OF THIS LIMITED WARRANTY. All warranty inspections, repairs and adjustments must be performed either by DCI or by a warranty claim service authorized in writing by DCI. All warranty claims must include proof of purchase, including proof of purchase date, identifying the DCI product by serial number, and be submitted before the end of the Warranty Period.
3. The Limited Warranty shall only be effective if: (i) within fourteen (14) days of receipt of the DCI product, User registers the DCI product with DCI through its product registration website at [access.DigiTrak.com](https://access.DigiTrak.com); (ii) User makes a reasonable inspection upon first receipt of the DCI product and immediately notifies DCI of any apparent defect; and (iii) User complies with all of the Warranty Claim Procedures described below.
4. The service period for this equipment is five years from the date of manufacture. During this period, DCI will support the repair or replacement of the products featured in this manual. A fee for repairs and replacements may be charged if the product is outside the warranty period.

## What is not covered

This Limited Warranty excludes all damage, including damage to any DCI product, due to: failure to follow DCI's operator's manual and other DCI instructions; use of a DCI product outside the specifications for which the DCI product is designed (including, without limitation, temperature); abuse; misuse; neglect; accident; fire; flood; Acts of God; improper applications; connection to incorrect line voltages and improper power sources; use of incorrect fuses; overheating; contact with high voltages or injurious substances; use of batteries or other products or components not manufactured or supplied by DCI; or other events beyond the control of DCI. This Limited Warranty does not apply to any equipment not manufactured or supplied by DCI nor, if applicable, to any damage or loss resulting from use of any DCI product outside the designated country of use. User agrees to carefully evaluate the suitability of the DCI product for User's intended use and to thoroughly read and strictly follow all instructions supplied by DCI (including any updated DCI product information which may be obtained from the DCI website). In no event shall this Limited Warranty cover any damage arising during shipment of the DCI product to or from DCI.

User agrees that the following will render the above Limited Warranty void: (i) alteration, removal or tampering with any serial number, identification, instructional, or sealing labels on the DCI product, or (ii) any unauthorized disassembly, repair or modification of the DCI product. In no event shall DCI be responsible for the cost of or any damage resulting from any changes, modifications, or repairs to the DCI product not expressly authorized in writing by DCI, and DCI shall not be responsible for the loss of or damage to the DCI product or any other equipment while in the possession of any service agency not authorized by DCI.

DCI does not warrant or guarantee the accuracy or completeness of data generated by HDD locating systems. The accuracy or completeness of such data may be impacted by a variety of factors, including (without limitation) active or passive interference (including from salt water) and other environmental conditions, failure to calibrate or use the device properly and other factors. DCI also does not warrant or guarantee, and disclaims liability for, the accuracy and completeness of any data generated by any external source or derived from data generated by any external source that may be displayed on a DCI device, including (without limitation) data received from any HDD drill rig.

DCI reserves the right to make changes in design and improvements upon DCI product from time to time, and User understands that DCI shall have no obligation to upgrade any previously manufactured DCI product to include any such changes.

**THE FOREGOING LIMITED WARRANTY IS DCI'S SOLE WARRANTY AND IS MADE IN PLACE OF ALL OTHER WARRANTIES, EXPRESS OR IMPLIED, INCLUDING BUT NOT LIMITED TO THE IMPLIED WARRANTIES OF MERCHANTABILITY AND FITNESS FOR A PARTICULAR PURPOSE, IMPLIED WARRANTY OF NON-INFRINGEMENT, AND ANY IMPLIED WARRANTY ARISING FROM COURSE OF PERFORMANCE, COURSE OF DEALING, OR USAGE OF TRADE, ALL OF WHICH ARE HEREBY DISCLAIMED AND EXCLUDED.** If DCI has substantially complied with the warranty claim procedures described below, such procedures shall constitute User's sole and exclusive remedy for breach of the Limited Warranty.

## Limitation of remedies and liability

**In no event shall DCI or anyone else involved in the creation, production, or delivery of the DCI product be liable for any damages arising out of the use or inability to use the DCI product, including but not limited to indirect, special, incidental, or consequential damages, or for any cover, loss of information, profit, revenue or use, based upon any claim by User for breach of warranty, breach of**

**contract, negligence, strict liability, or any other legal theory, even if DCI has been advised of the possibility of such damages. In no event shall DCI's liability exceed the amount User has paid for the DCI product. To the extent that any applicable law does not allow the exclusion or limitation of incidental, consequential or similar damages, the foregoing limitations regarding such damages shall not apply.**

This Limited Warranty gives you specific legal rights, and you may also have other rights which vary from state to state. This Limited Warranty shall be governed by the laws of the State of Washington.

## Warranty claim procedures

1. If you are having problems with your DCI product, you must first contact the Authorized DCI Dealer where it was purchased. If you are unable to resolve the problem through your Authorized DCI Dealer, contact DCI's Customer Service Department in Kent, Washington, USA at 1.800.288.3610 (or, for international markets, the corresponding telephone number for that market) between 6:00 AM and 6:00 PM Pacific Time and ask to speak with a customer service representative. Prior to returning any DCI product to DCI for service, you must obtain a Return Merchandise Authorization (RMA) number. Failure to obtain an RMA may result in delays or return to you of the DCI product without repair.
2. After contacting a DCI customer service representative by telephone, the representative will attempt to assist you in troubleshooting while you are using the DCI product during actual field operations. Please have all related equipment available together with a list of all DCI product serial numbers. It is important that field troubleshooting be conducted because many problems do not result from a defective DCI product, but instead are due to either operational errors or adverse conditions occurring in User's drilling environment.
3. If a DCI product problem is confirmed as a result of field troubleshooting discussions with a DCI customer service representative, the representative will issue an RMA number authorizing the return of the DCI product and will provide shipping directions. You will be responsible for all shipping costs, including any insurance. If, after receiving the DCI product and performing diagnostic testing, DCI determines the problem is covered by the Limited Warranty, required repairs and/or adjustments will be made, and a properly functioning DCI product will be promptly shipped to you. If the problem is not covered by the Limited Warranty, you will be informed of the reason and be provided an estimate of repair costs. If you authorize DCI to service or repair the DCI product, the work will be promptly performed and the DCI product will be shipped to you. You will be billed for any costs for testing, repairs and adjustments not covered by the Limited Warranty and for shipping costs. In most cases, repairs are accomplished within 1 to 2 weeks.
4. DCI has a limited supply of loaner equipment available. If loaner equipment is required by you and is available, DCI will attempt to ship loaner equipment to you by overnight delivery for your use while your equipment is being serviced by DCI. DCI will make reasonable efforts to minimize your downtime on warranty claims, limited by circumstances not within DCI's control. If DCI provides you loaner equipment, your equipment must be received by DCI no later than the second business day after your receipt of loaner equipment. You must return the loaner equipment by overnight delivery for receipt by DCI no later than the second business day after your receipt of the repaired DCI product. Any failure to meet these deadlines will result in a rental charge for use of the loaner equipment for each extra day the return of the loaner equipment to DCI is delayed.

## Product demonstrations

DCI personnel may be present at a jobsite to demonstrate basic usage, features, and benefits of DCI products. User acknowledges that DCI personnel are present only to demonstrate a DCI product. DCI does NOT provide locating services or other consulting or contracting services. DCI does not assume any duty to train User or any other person, and does not assume responsibility or liability for the locating or other work performed at a jobsite at which DCI personnel or equipment are or have been present.