

*User's Manual*

# PLASMA DISPLAY Monitor

MODEL : DPD - 4200AK

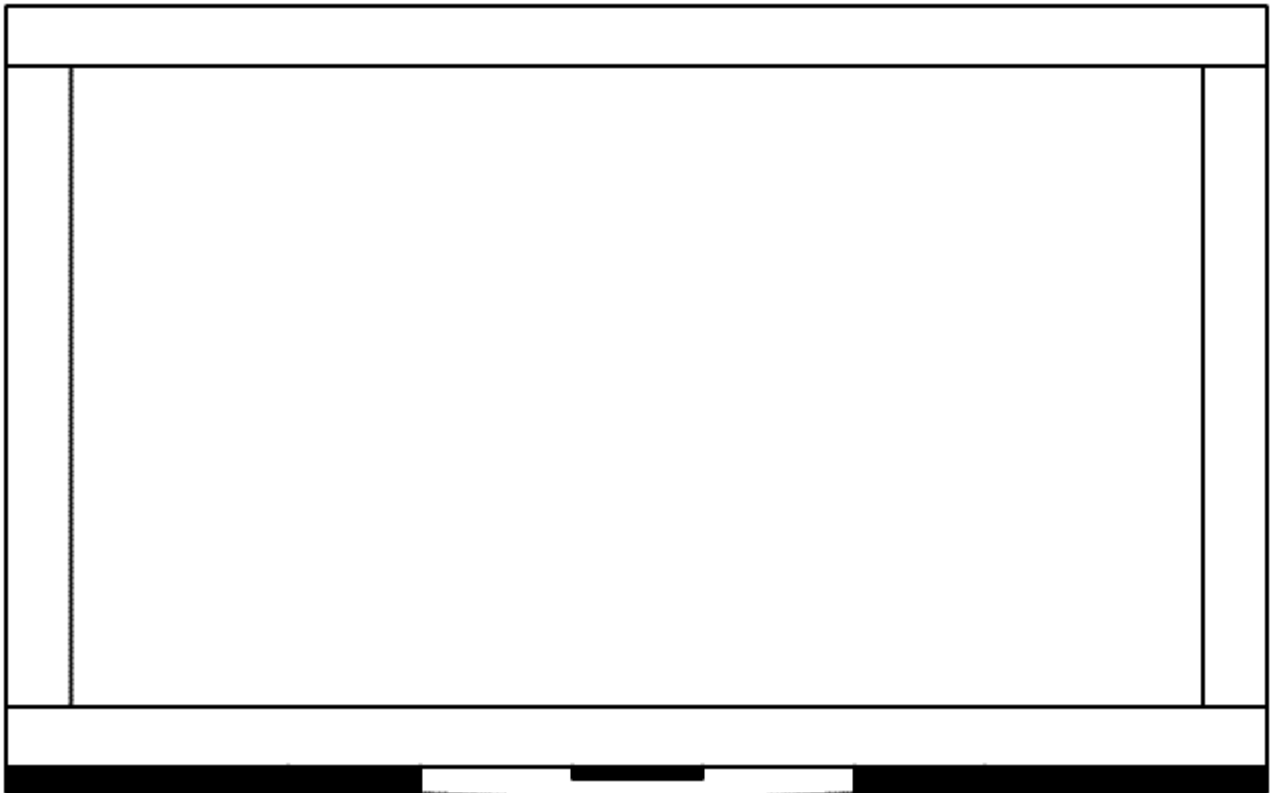

**It's the creative world of plasma display**



## WARNING

RISK OF ELECTRICAL SHOCK, DO NOT OPEN



**CAUTION : TO REDUCE THE RISK OF ELECTRICAL SHOCK, DO NOT REMOVE COVER(OR BACK). NO USER SERVICEABLE PARTS INSIDE. REFER SERVICING TO QUALIFIED SERVICE PERSONNEL.**



The lightning flash with the arrowhead symbol, within an equilateral triangle, is intended to alert the user to the presence of uninsulated "dangerous voltage" within the product's enclosure that may be of sufficient magnitude to constitute an electric shock to persons.



The exclamation point within an equilateral triangle is intended to alert the user to the presence of important operating and maintenance (servicing) instructions in the literature accompanying the appliance.

# Manual Contents

---

## Manual Contents

Manual Contents		3
Features and Package Contents	- Features	4
	- Packages Contents	4
I/O Definitions		5
Front and Rear Controls	- Front	6
	- Rear Controls	6
Remote Control	- Remote Control Basic	7
	- Remote Control Details	8
Basic Operation	- AV Input/Output Terminal	10
	- TV	10
	- Video	10
	- S-VHS	11
	- SCART	11
	- Monitor Out Connection	12
	- Component Video	12
	- PC	13
	- External Speaker & Headphone Connection	13
TV Channel Memory	- Auto Channel Memory	14
	- Manual Channel Memory	15
Picture	- Picture Adjustment	16
	- Picture Size Adjustment	17
	- Picture Adjustment in PC Mode	18
	- Picture Size Adjustment in PC Mode	19
Audio	- Audio Mode Setting	20
	- Audio Adjustment	21
Picture in Picture	- Picture in Picture Mode Setting	22
	- Watching Picture in Picture	23
Video Signal Format	- Video Signal Format Setting	24
Color Temperature	- Color Temperature Setting	25
Specifications		26
Troubleshooting		27

# Features and Package

---

## Features

- 42" Diagonal Viewing Area
- Menu driven On Screen Display (OSD) for Brightness and Contrast, Sharpness, Hue and Saturation , NTSC/PAL, Channel, PIP(Picture in Picture), Aspect Ratio, Input Source, Audio, Audio Adjust, Language, Color Temperature
- Cable TV ready
- IR Remote control for all functions
- Built-in Television Tuner
- Zoom Feature (up to 500%)
- Freeze Picture Feature
- Rotate Picture Feature
- Headphone output (only sub sound)
- Speaker output : Left, Right, Center, Surround-L, Surround-R, Sub-Woofer
- Selectable Aspect Ratio (16:9, 4:3, User Adjusting Mode)
- PIP (Picture in Picture) Function
- Multiple Mounting Options : Wall mount or Stand
- Monitor Composite Video Output
- Large Viewing Angle (160 °)
- Seven (7) Possible Video Sources :
  - 1 PC
  - 2 External RCA A/V Inputs
  - 1 S-VHS Input
  - 1 SCART Input
  - 1 Component Video Input
  - 1 TV

## Package Contents

- 42" Plasma TV
- User's Manual
- Full function Remote Control
- A set of three AAA Batteries for Remote Control
- AV Cord
- AC Power Cord

# I/O Definitions

---

## Front Panel Controls

- Main Power ON/OFF
- Power ON/OFF
- Channel UP
- Channel DOWN
- Volume UP
- Volume DOWN
- AV

## Rear Unit I/O's

- AC Power Input
- F-Type (NTSC) or Din-Type (PAL) Connector for Antenna Input
- Monitor Composite Video Output
- Monitor Line Level Audio Output
- S-VHS Input
- Composite Video Input (2)
- Line Level Audio Input (2)
- SCART Input/Output
- DVD Component Video Input
- DVD Line Level Audio Input
- PC D-sub Connector Input
- PC Headphone Audio Input
- Headphone Audio Output
- Speaker Output : Left, Right, Center, Surround-L, Surround-R, Sub-woofer

# Front and Rear Controls

## Front

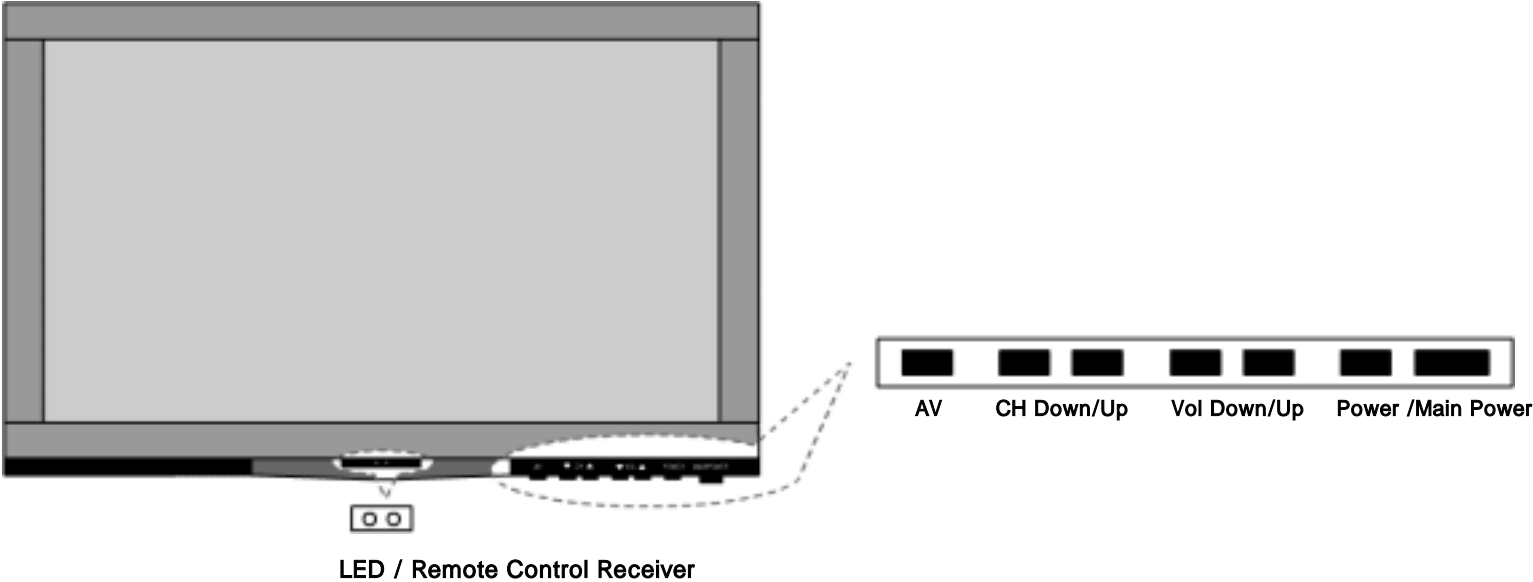

## Rear Controls

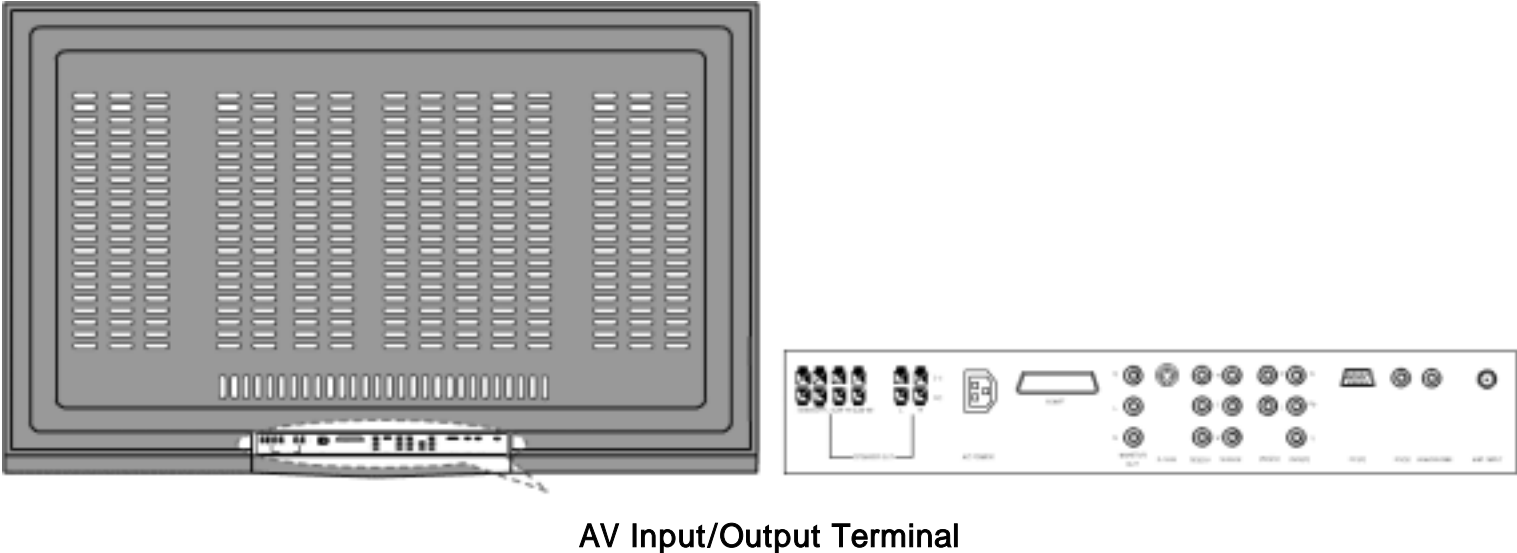

The recessed AV input/output terminals allow the user to have the option of using the mounting stand or wall mounting the 42" Plasma Television. The television itself is only 95mm wide.

# Remote Control

## Remote Control Basic

### AV Buttons

( PC / VIDEO1 / VIDEO2 / VIDEO3 / TV )

Use this button for signal selection.

### CH/VOL BUTTONS

These buttons are used to adjust the channel selected and the volume level.

### Menu Button

The center button is used to pull up the menu screen. The surrounding buttons are used to make adjustments to the menu item selected. (ex. Picture, Sound and PIP adjustments)

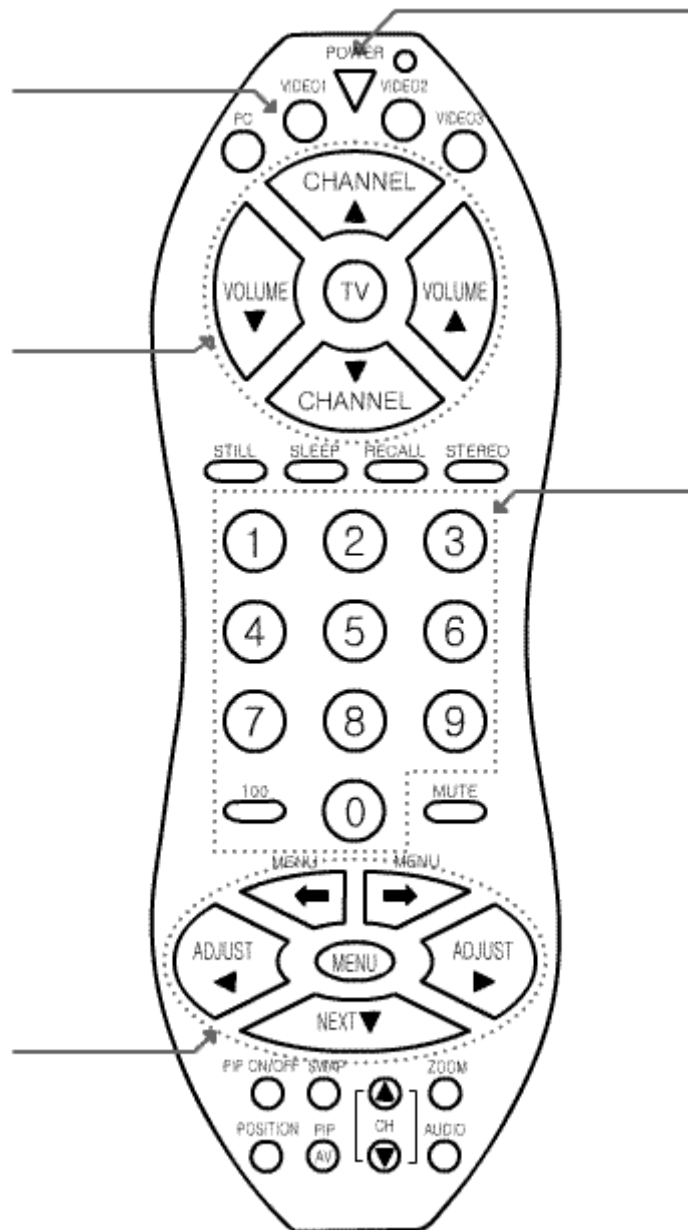

### POWER

Pressing this button turns the television ON and OFF.

### Number Buttons

Used to enter channels selected.

# Remote Control

## Remote Control Details

### STILL

Pressing this button will stop/freeze the picture.

### SLEEP

This button allows the user to set the sleep timer.

### RECALL

This button will allow the user to view the setting status.

### STEREO

Allows MONO, STEREO or SAP mode selection.

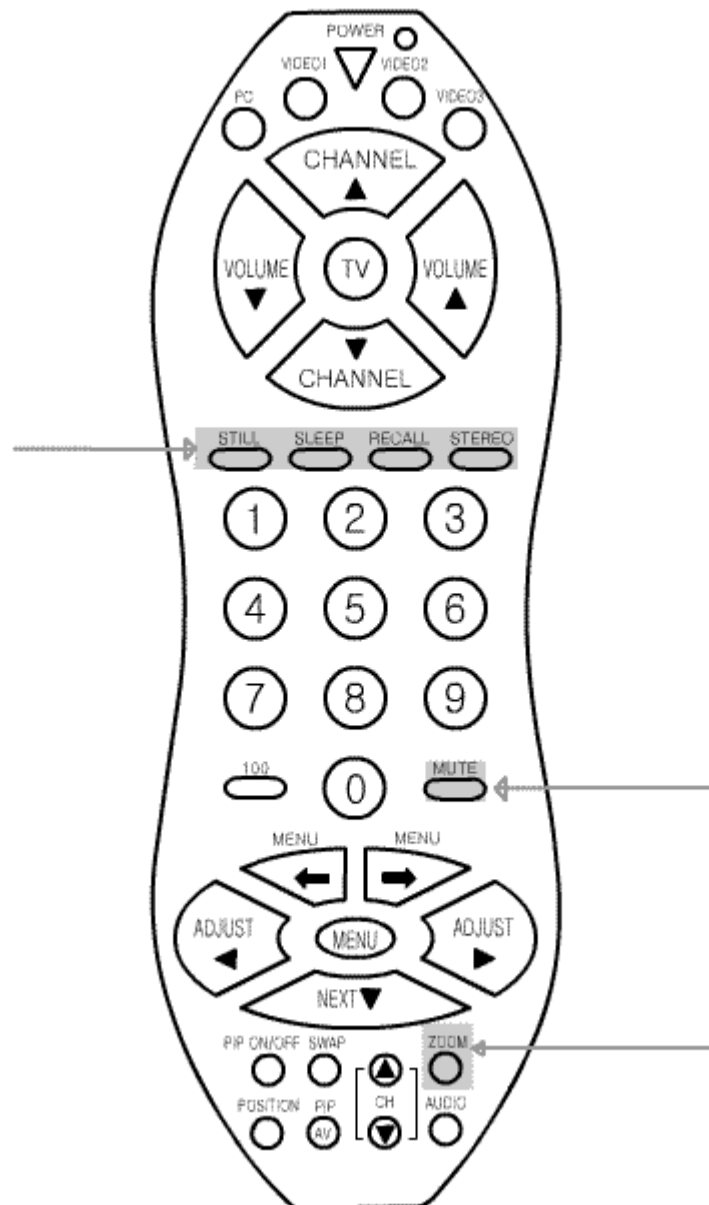

### MUTE

This button mutes the televisions

### ZOOM

Pressing the up and down buttons allows the user to zoom in or out the picture.



# Remote Control

---

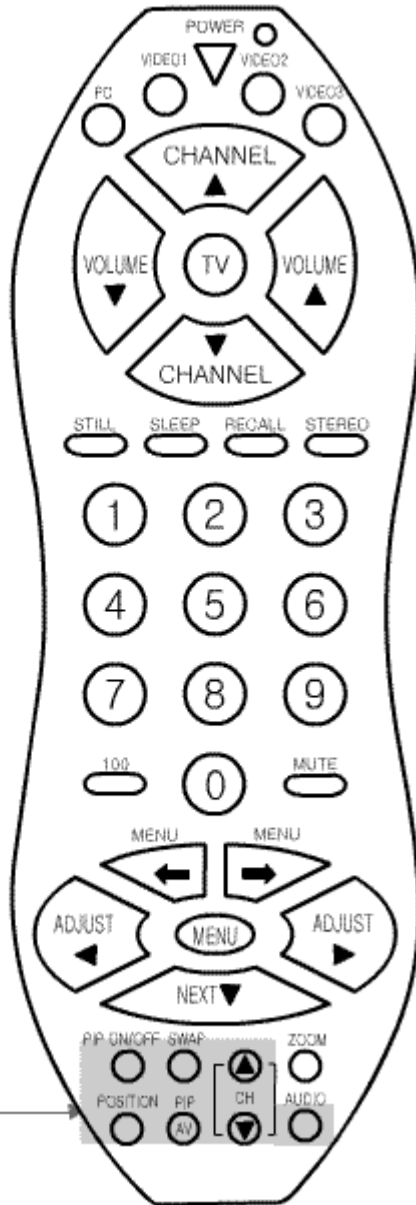

## PIP ON/OFF

Pressing this button toggles picture in picture on and off.

## SWAP

This button allows the user to swap the picture in picture for picture on the main screen.

## POS

This button switches the screen location of the picture in picture viewing screen. There are four possible screen locations for the picture in picture.

## CH /

Pressing this button up or down allows channel selection of the picture in picture.

## PIP AV

This button switches the mode selection of the picture in picture viewing screen.

## AUDIO

This button switches the Speaker Out of picture in picture Mode.

# Basic Operation

## 1. AV Input/Output Terminal

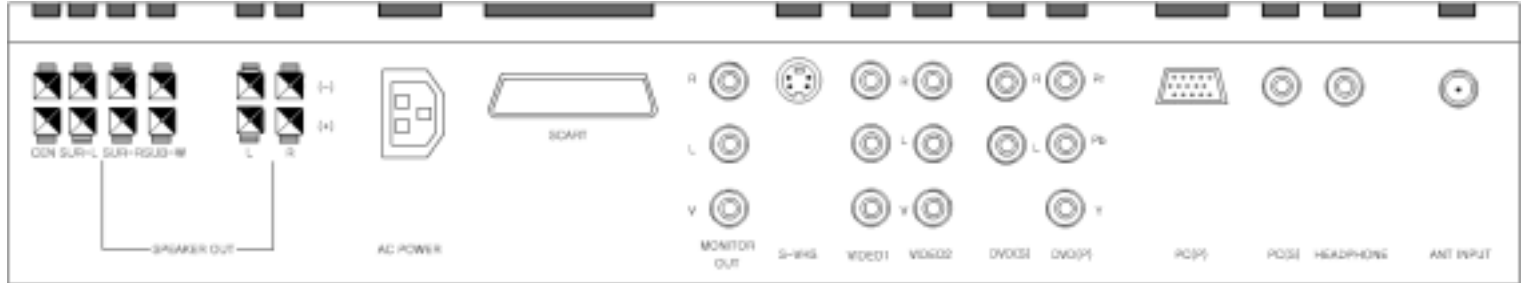

## 2. TV

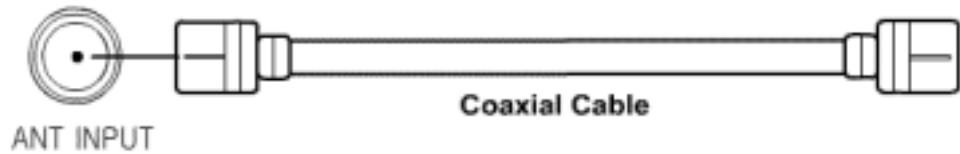
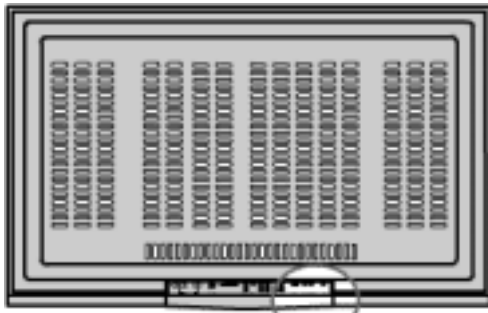

1. Connect as the shown drawing.
2. Power on.
3. Press the [TV] button.

## 3. VIDEO

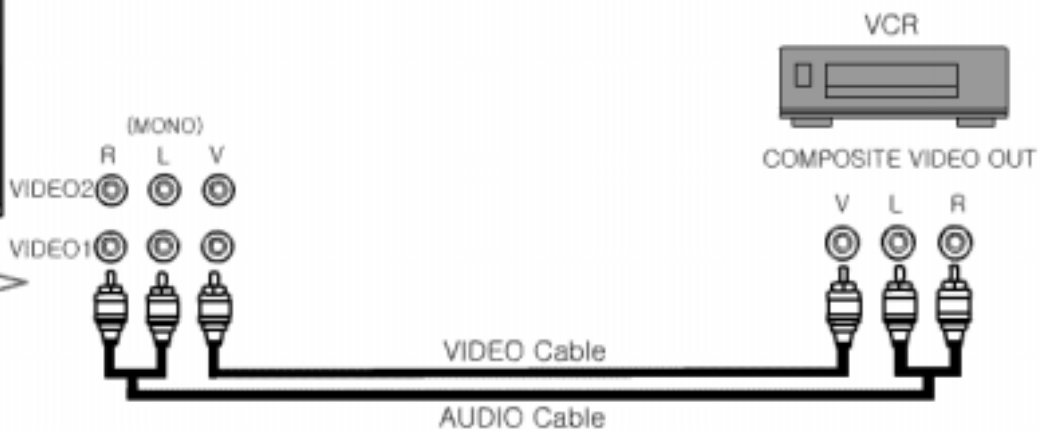
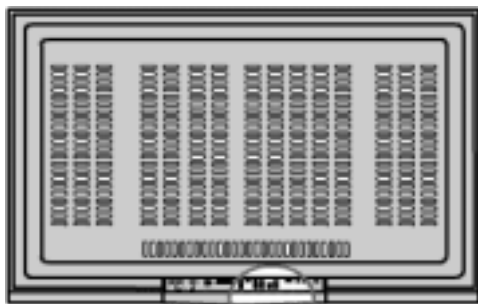

1. Connect as the shown drawing.
2. Power on.
3. Press the [VIDEO1] or [VIDEO2] button.

# Basic Operation

## 4. S-VHS

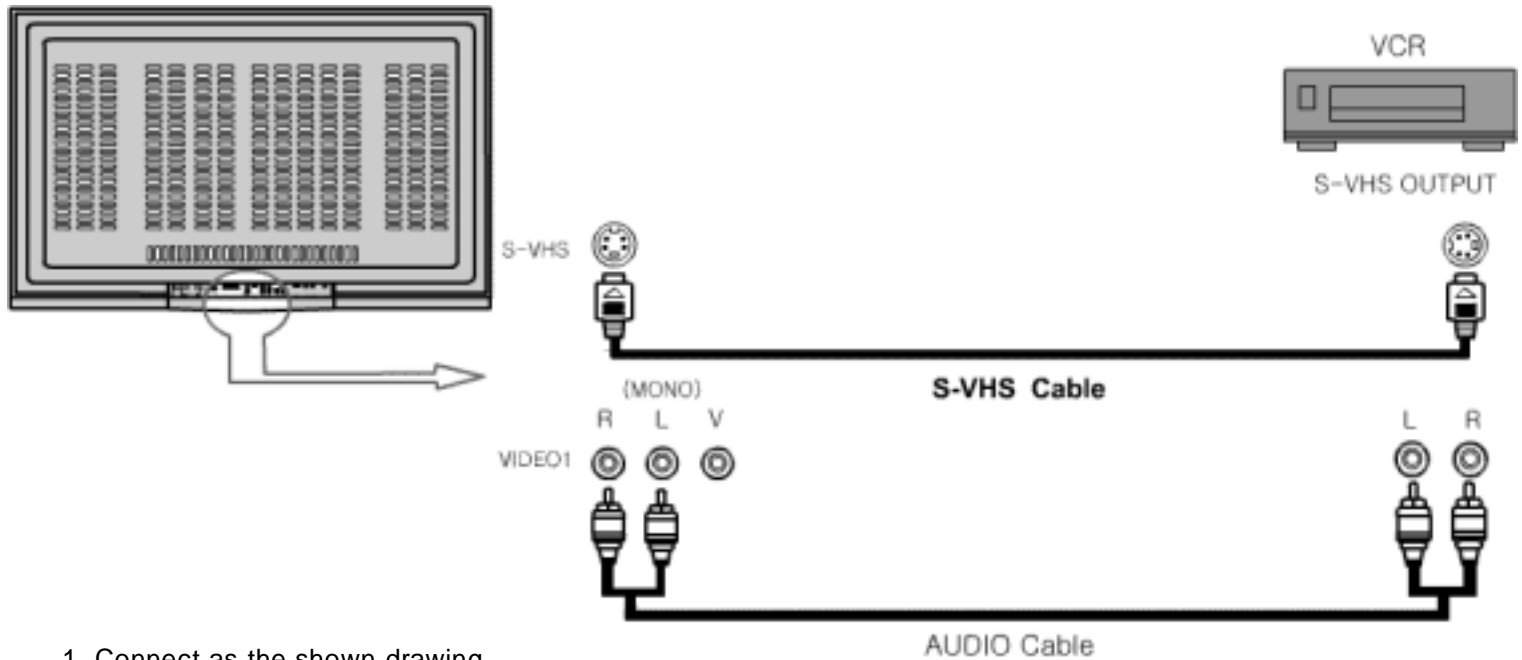

1. Connect as the shown drawing.
2. Power on.
3. Press the [VIDEO1] button.

**<Caution>** Audio input must be connected with [Video1].

In the case when all input sources of S-VHS and Video1 Port are occupied, S-VHS input Sources display preceding to Video1 Port.

## 5. SCART Connection

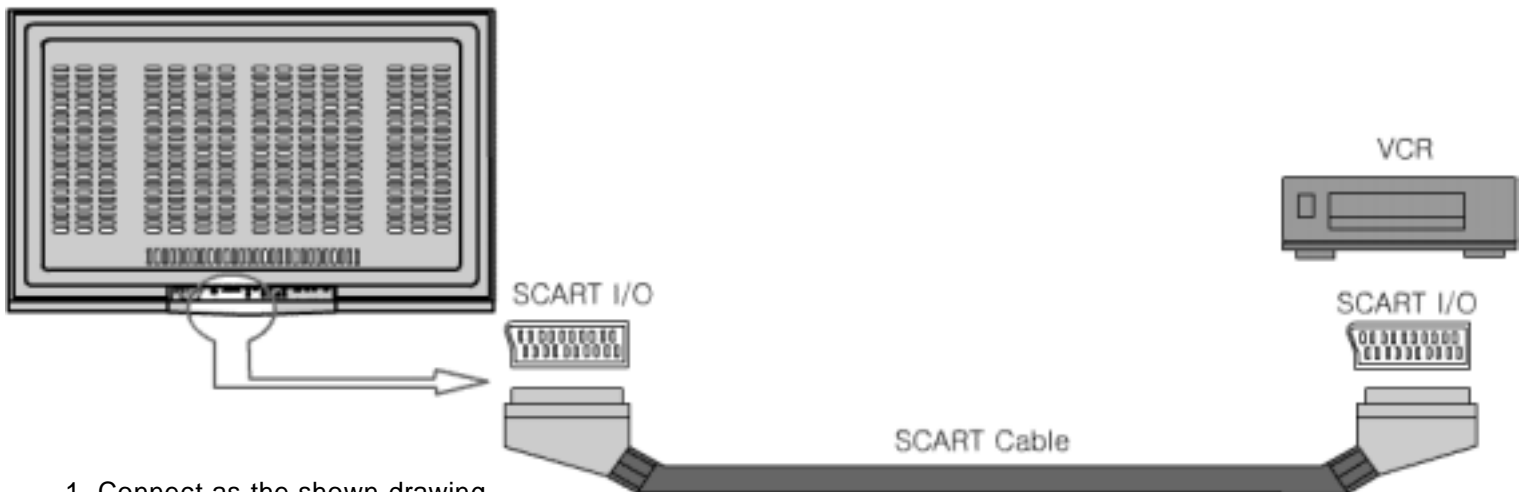

1. Connect as the shown drawing.
2. Power on.
3. Press the [VIDEO2] button.

**<Caution>** In the case when all input sources of SCART and Video2 Port are occupied, SCART input Sources display preceding to Video2 Port.

# Basic Operation

## 6. MONITOR OUT Connection

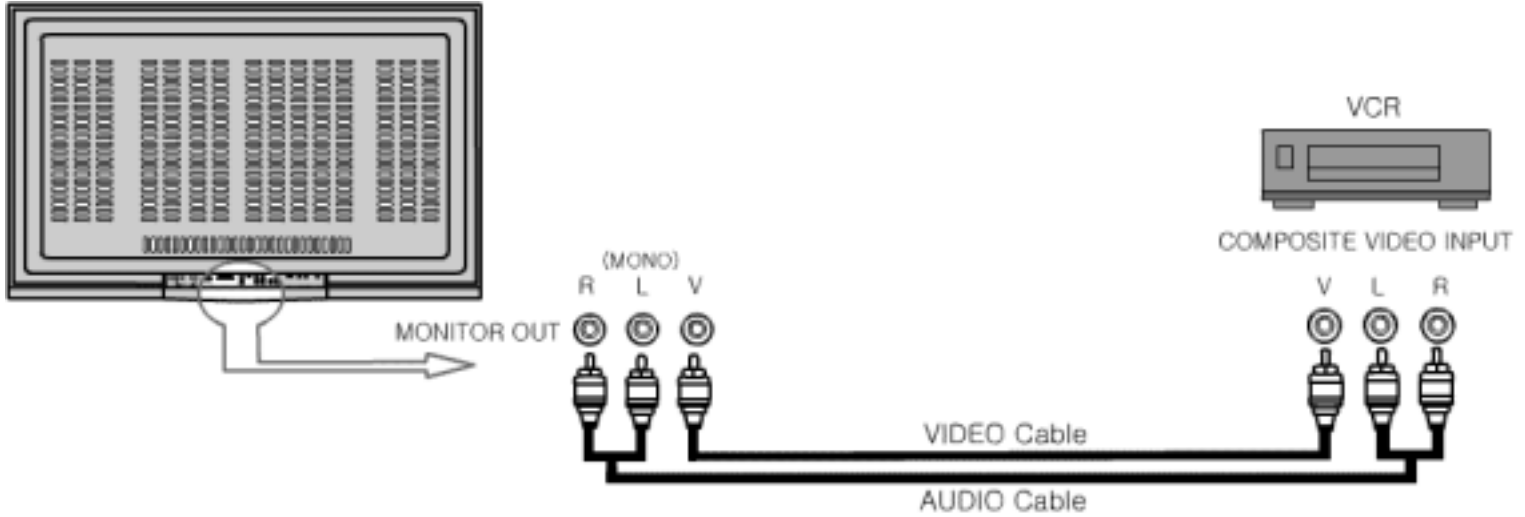

<Caution> Monitor out is only applied to [TV], [VIDEO1], [VIDEO2].

## 7. COMPONENT Video (ex. DVD, DTV Set-top Box)

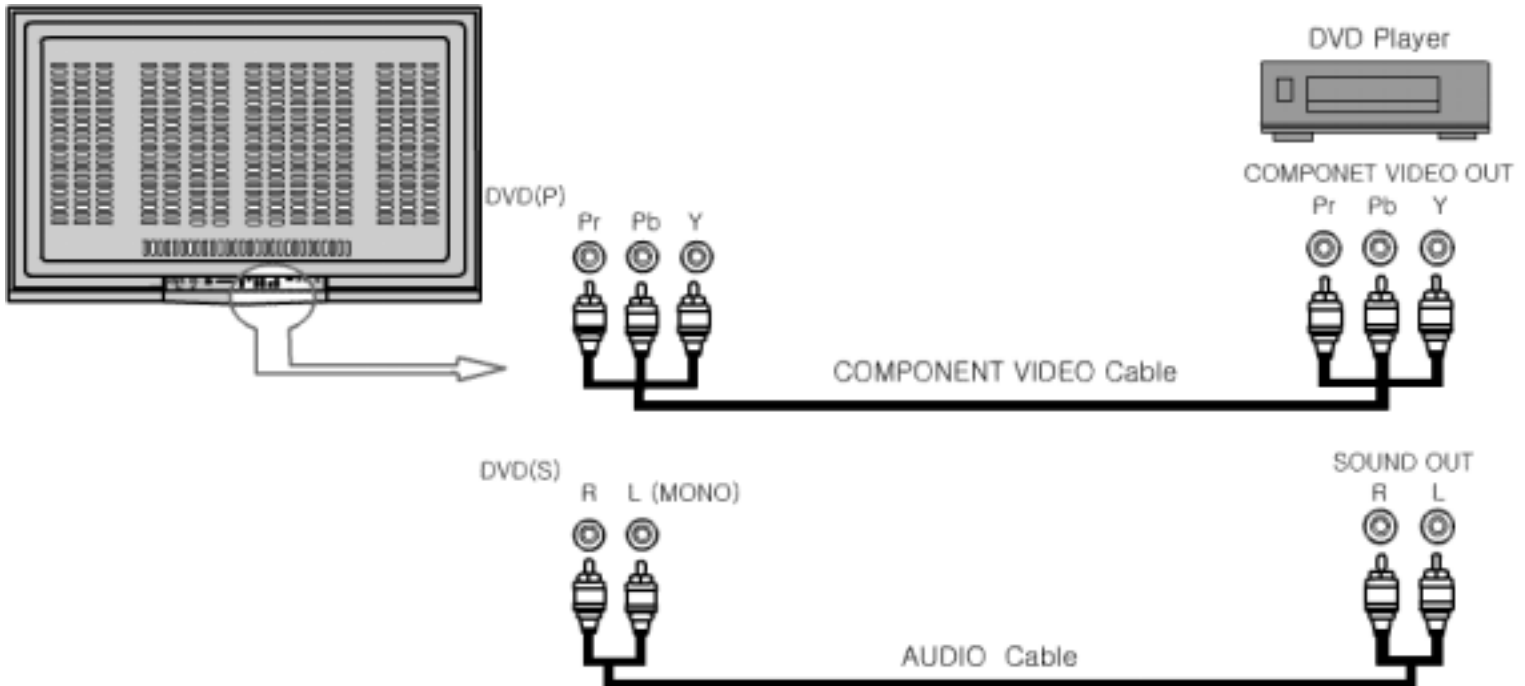

1. Connect as the shown drawing.
2. Power on.
3. Press the [VIDEO3] button.

# Basic Operation

## 8. PC

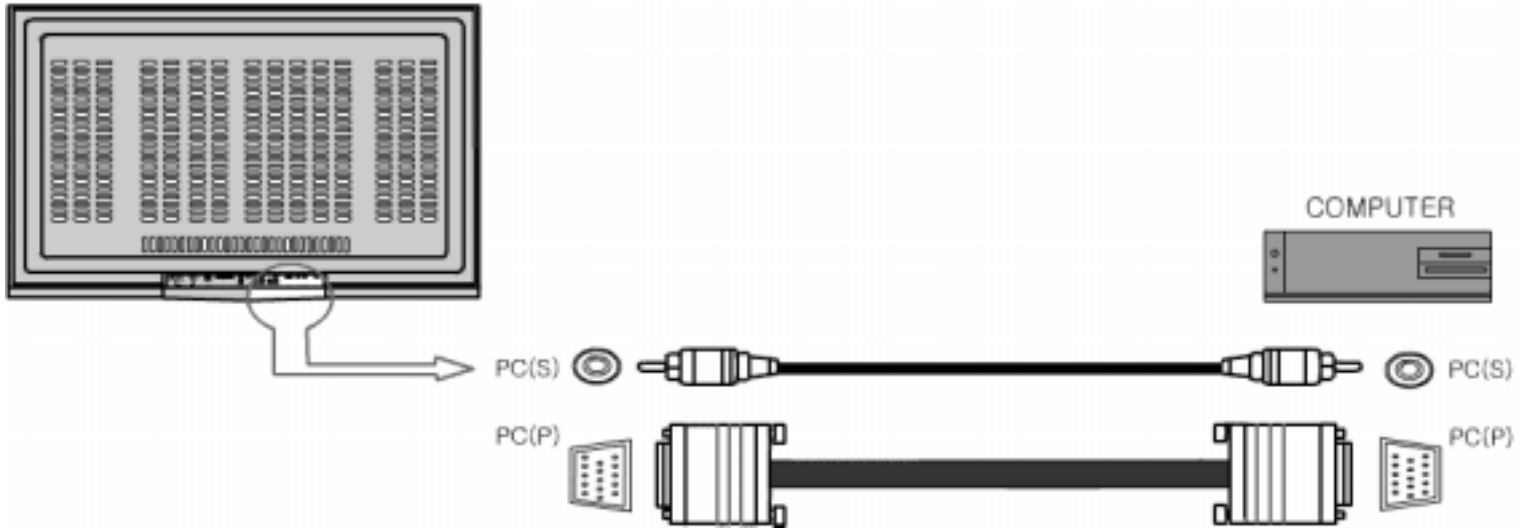

1. Connect as the shown drawing.
2. Power on.
3. Press the [PC] button.

## 9. External Speaker & Headphone Connection

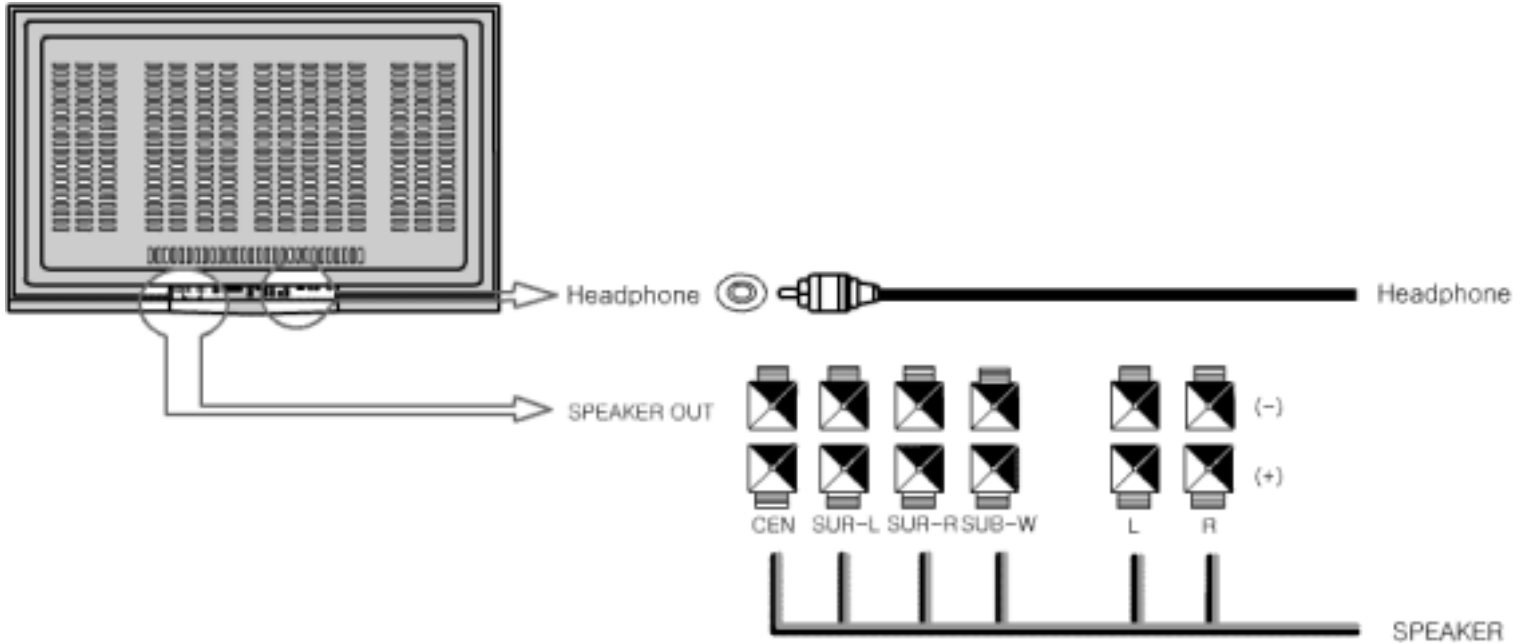

1. Power Off.
  2. Connect as the shown drawing.
  3. Power on.
  4. Adjusting Audio setting.
- <Caution> Headphone outputs Sub-Signal Sounds.

# TV Channel Memory

## Auto Channel Memory

Follow these steps for setting the Channel Memory automatically:

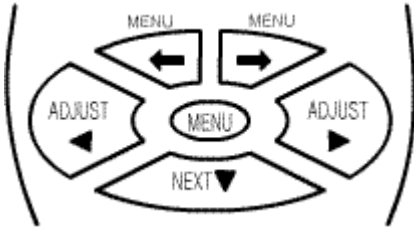

- ① Press the [MENU] button.
- ② Select [Channel] by the [←]/[→] buttons.
- ③ Select [Status] by pressing the [NEXT] button.
- ④ Select TV signal input mode by pressing the [ADJUST] button.
- ⑤ Select [Auto Channel] by pressing the [NEXT] button.
- ⑥ Select [ON] by pressing the [ADJUST] buttons.
- ⑦ Press the [MENU] button to stop the auto channel memory.

Highlighted choice will be in green.

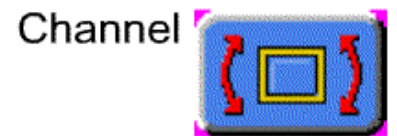
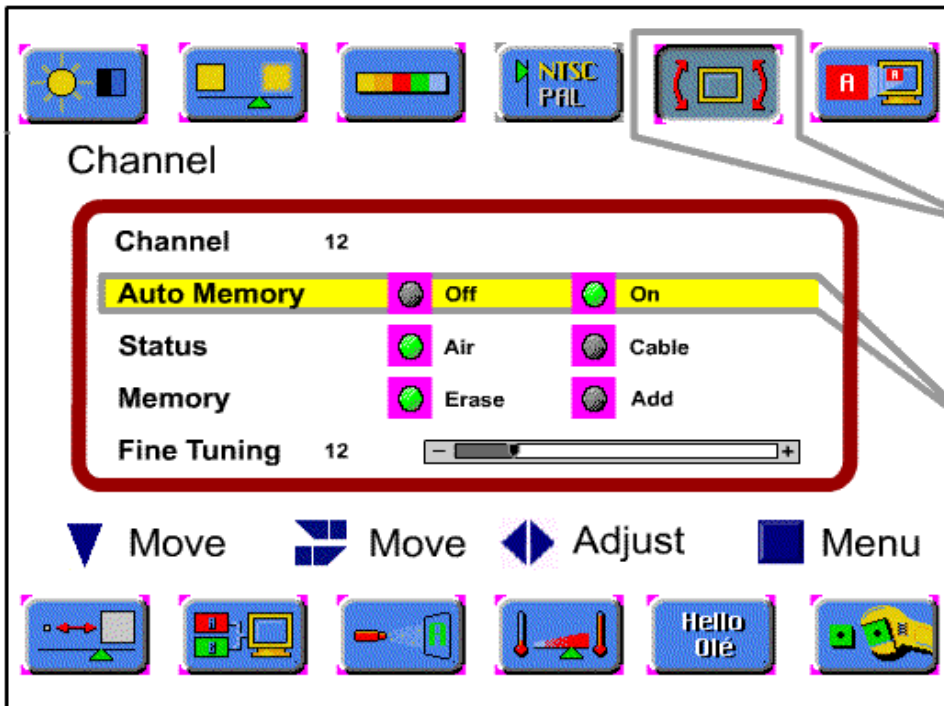

### Auto Memory

When Auto memory is on, it will scan CH 2 - 69 on the Air setting and CH 1 - 125 on the Cable setting.

# TV Channel Memory

## Manual Channel Memory

Follow these steps to manually set the Channel Memory :

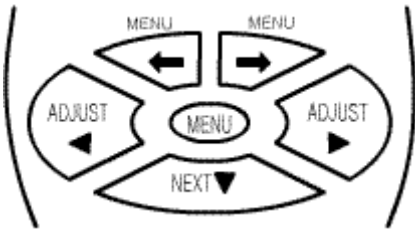

- ① Select the channel by pressing the number button(s).
- ② Press the [MENU] button.
- ③ Select [Channel] by the [←]/[→] buttons.
- ④ Select [Fine Tuning] mode by using the [NEXT] button.
- ⑤ Press the [ADJUST] button for the tuning adjustment.
- ⑥ Select [Memory] by using the [NEXT] button.
- ⑦ Select [Erase] or [Add] by pressing the [ADJUST] buttons.
- ⑧ Press the [MENU] button to exit the Channel Memory setting.

Highlighted choice will be in green.

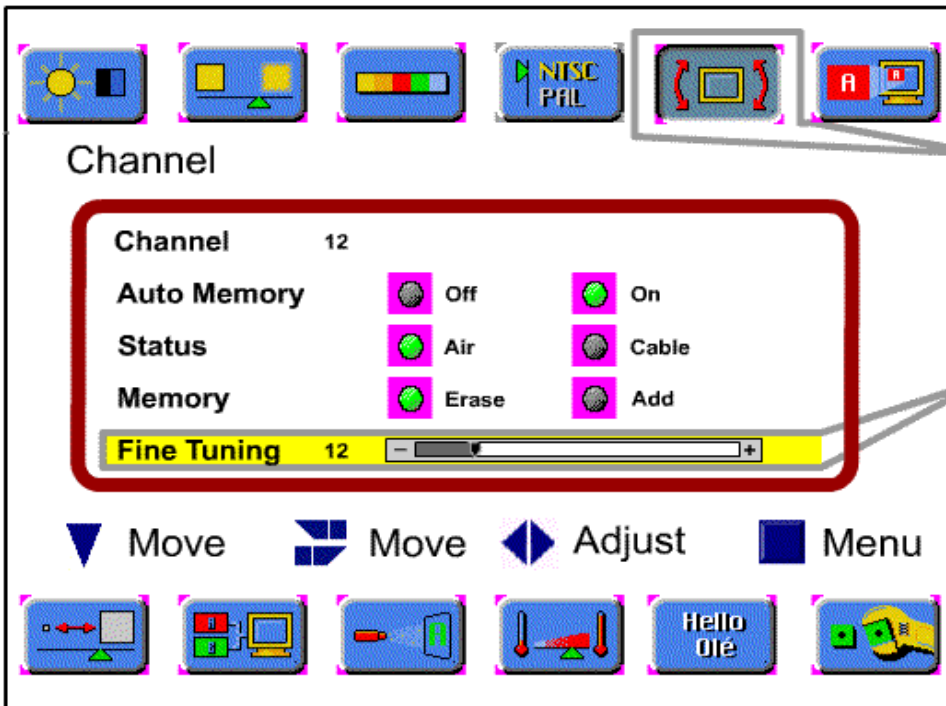

### Fine Tuning

The [ADJUST] button on the remote control will move the slide adjustment of the fine tuning bar positively or negatively.

# Picture

## Picture Adjustment

Follow these steps to adjust the picture :

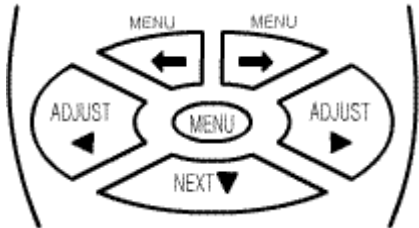

- ① Press the [MENU] button.
- ② Select the desired Mode by using the [←]/[→] buttons.
- ③ Move to the desired Mode by pressing the [NEXT] button.
- ④ Press the [ADJUST] button for adjusting the picture
- ⑤ Press the [MENU] button to exit the adjustment menu.

Brightness and Contrast

Sharpness

Hue and Saturation

Highlighted choice will be in green.

Brightness 123

Contrast 123

Picture Mode  Soft  Dark  Bright  User

▼ Move    ◻ Move    ◄ Adjust    ■ Menu



# Picture

## Picture Size Adjustment

Follow these steps to adjust the picture size :

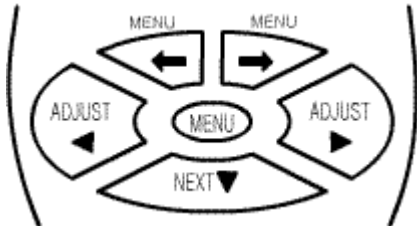

- ① Press the [MENU] button.
- ② Select the Aspect Ratio by using the [←]/[→] buttons.
- ③ Move to the desired Mode by pressing the [NEXT] button.
- ④ Press the [ADJUST] button to adjust the picture size ratio.
- ⑤ Press the [MENU] button to exit Picture Size Adjustment.

Highlighted choice will be in green.

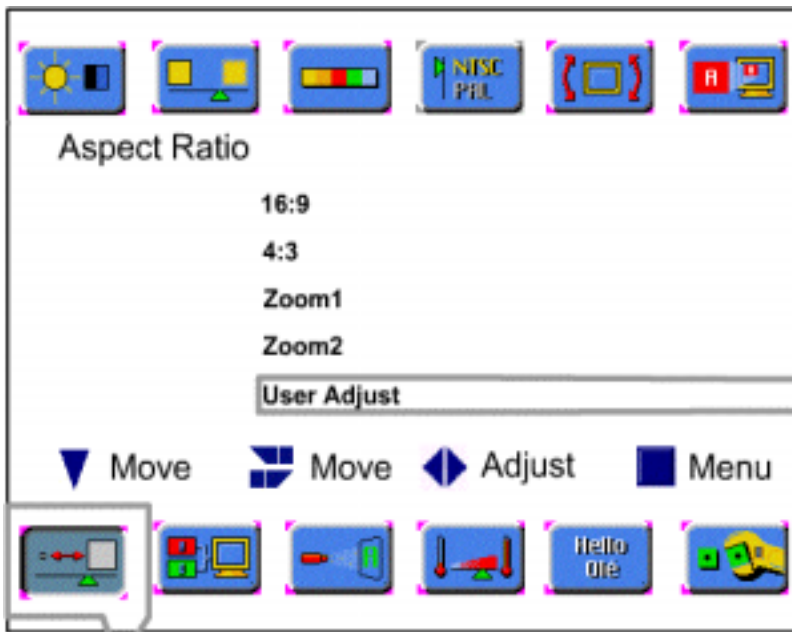

At User Adjusting Setting



Aspectio Ratio

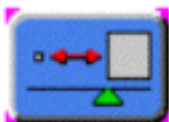

### [ZOOM + ] / [ZOOM - ] Button

: Using the [ZOOM] button on the remote controller, you can expand the picture size 0 up to 500%.

# Picture

## Picture Adjustment in PC Mode

Follow these steps to adjust the picture in PC Mode :

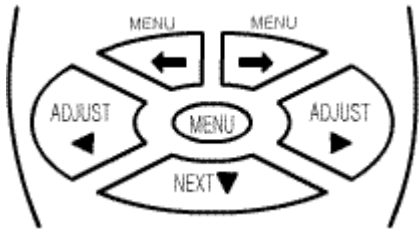

- ① Press the [MENU] button.
- ② Select the desired Mode by using the [←]/[→] buttons.
- ③ Move to the desired Mode by pressing the [NEXT] button.
- ④ Press the [ADJUST] button for adjusting the picture in PC Mode
- ⑤ Press the [MENU] button to exit the adjustment menu.

Brightness and Contrast



Sharpness



Frequency and Phase



Status



Position

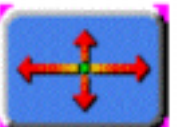

Highlighted choice will be in green.

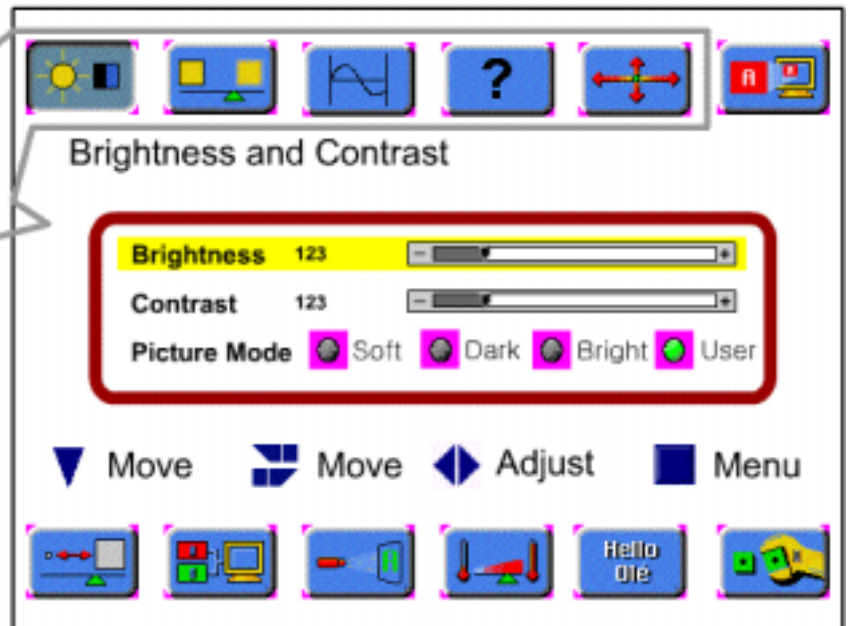

# Picture

## Picture Size Adjustment in PC Mode

Follow these steps for setting the Picture Size Adjustment of PC Mode.

① Press the [MENU] button.

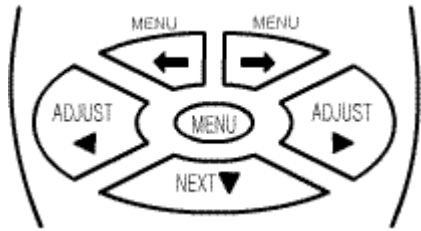

② Select the Normal Scaling Modes by using the [←]/[→] uttons.

③ Move to the desired mode by pressing the [NEXT] button.

④ Press the [ADJUST] button to select the proper mode.

⑤ Press the [MENU] button to exit the adjustment menu.

Highlighted choice will be in green.

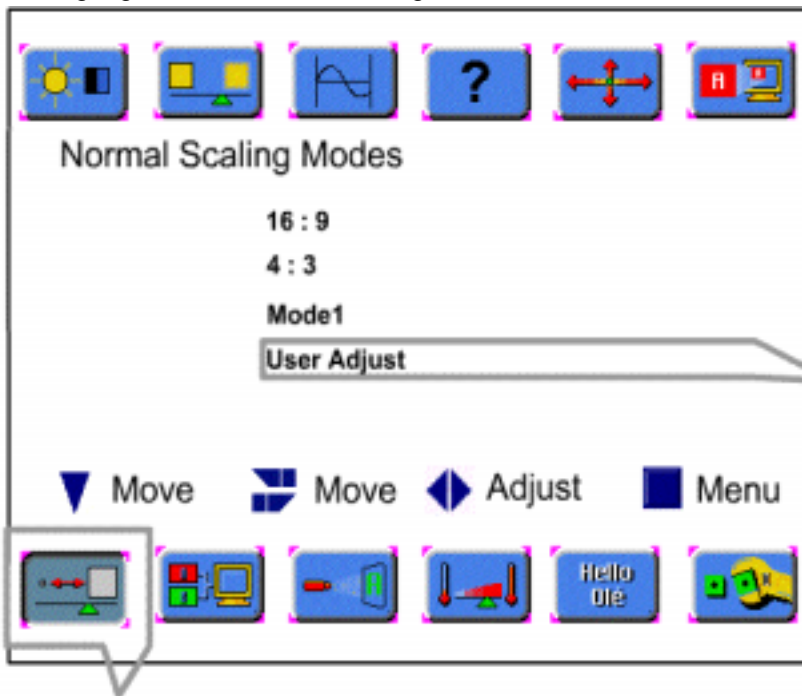

At User Adjusting Setting



Normal Scaling Modes

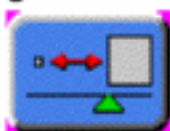

### [ZOOM + ] / [ZOOM - ] Button

: Using the [ZOOM] button on the remote controller, you can expand the picture size 0 up to 500%.

# Audio

## Audio Mode Setting

Follow these steps for setting Sound Mode :

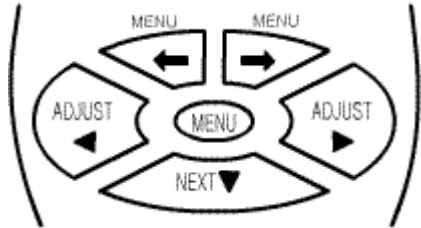

- ① Press the [MENU] button.
- ② Select the Audio by using the [←]/[→] buttons.
- ③ Move to the desired Mode by pressing the [NEXT] button.
- ④ Press the [ADJUST] button to make the adjustment for Sound
- ⑤ Press the [MENU] button to exit the adjustment menu.

Highlighted choice will be in green.

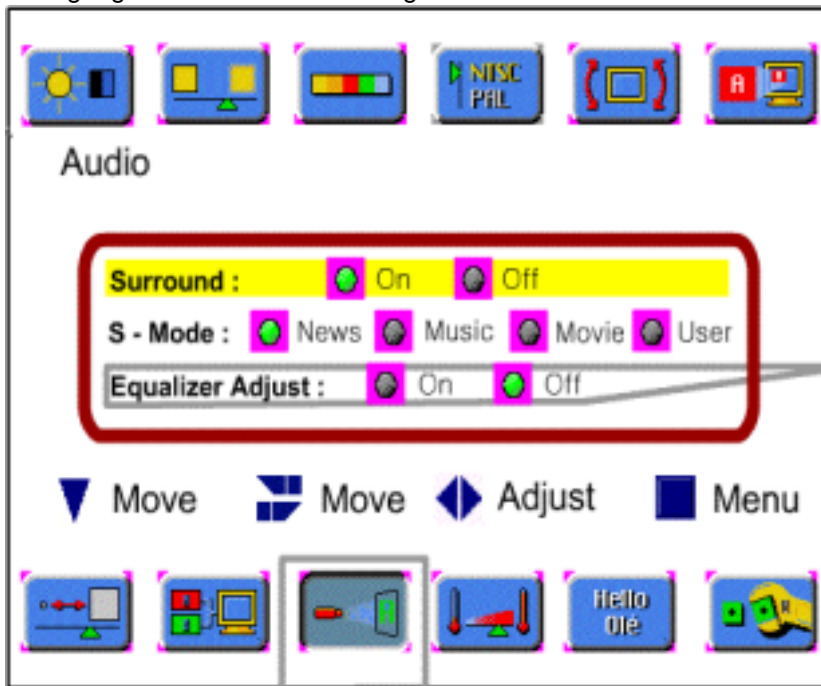

At Equalizer Adjust On  
Equalizer

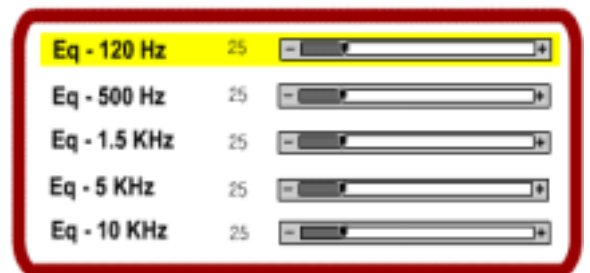

Audio



# Audio

## Audio Adjustment

Follow these steps to adjust the Sound :

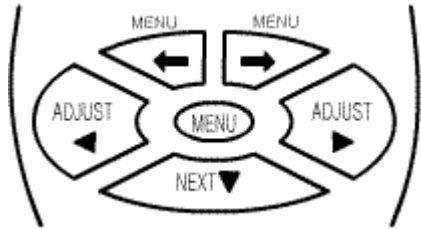

- ① Press the MENU button.
- ② Select the Audio Adjust by using the [←]/[→] buttons.
- ③ Move to the desired Mode by pressing the [NEXT] button.
- ④ Press the [ADJUST] button to make the adjustment for Sound
- ⑤ Press the [MENU] button to exit the adjustment menu.

Highlighted choice will be in green.

Audio Adjust

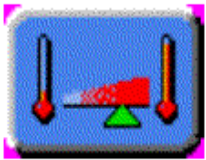

A screenshot of a television's audio adjustment menu. The menu is titled 'Audio Adjust' and contains four options: Bass, Treble, Balance, and Cen/Sur Balance. Each option has a numerical value (all are 25) and a horizontal slider. The 'Bass' option is highlighted in green. Below the menu are four navigation buttons: a downward arrow labeled 'Move', a square with four arrows labeled 'Move', a leftward arrow labeled 'Adjust', and a blue square labeled 'Menu'. At the bottom of the screen, there are several other menu options, including 'Hello Olé' and a yellow icon.

**BASS** : Changes the level of low frequency sound.

**TREBLE** : Changes the level of high frequency sound

**BALANCE** : Changes the balance of the left and right channels.

**Cen/Sur BALANCE** : Changes the balance of the center and surround channels.

# Picture in Picture

## Picture in Picture Mode Setting

Follow these steps below to set Picture in Picture mode :

- ① Press the [MENU] button.
- ② Select Picture in Picture by using the [←]/[→] button.
- ③ Select PIP size mode by pressing the [NEXT] button.
- ④ Move to desired mode by pressing the [ADJUST] button.
- ⑤ Select PIP Source Mode by pressing the [NEXT] button.
- ⑥ Select PIP Source by pressing the ADJUST button.
- ⑦ Press the [MENU] button to exit the adjustment menu.

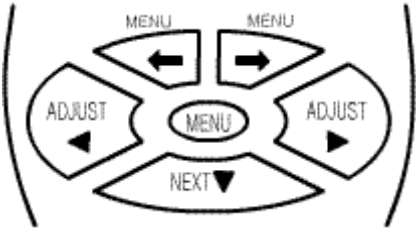

## Picture in Picture

Highlighted choice will be in green.

Picture in Picture

PIP Size  Off  1  2  3

PIP Source  V1  V2  V3  Tv

Rotate :  On  Off

▼ Move    ◀ Move    ▶ Adjust    ■ Menu

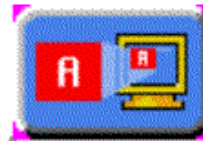

PiP Size

Mode1

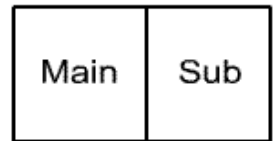

Mode2

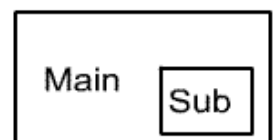

Mode3

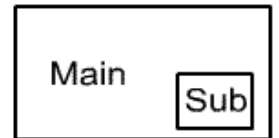

PiP Size at PC Mode

Mode1

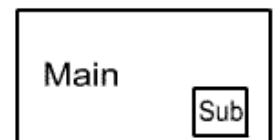

Mode2

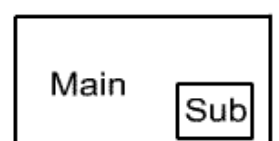

# Picture in Picture

## Watching Picture in Picture

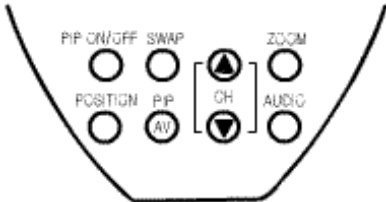

<b>Watching PIP</b>	Press the [PIP ON/OFF] button.
<b>Changing the Sub Picture to AV</b>	Press the [PIP AV] button.
<b>Changing the Sub Picture Channel</b>	Press the [ CH ] button.
<b>Changing the Sub Picture Position</b>	Press the [POS] button.
<b>Swapping Main for Sub picture</b>	Press the [SWAP] button.

### PIP at PC Mode

PC signal can be seen on the main picture but not on the sub picture. AT 800×600 mode, you can optimize PIP.

# Video Signal Format

## Video Signal Format Setting

Follow these steps for setting the Video Signal Format.

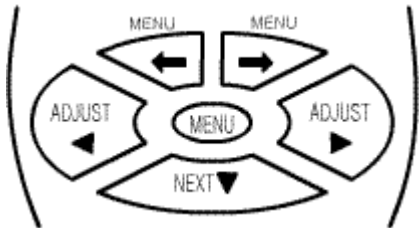

- ① Press the [MENU] button.
- ② Select the Video Mode by using the [←]/[→] buttons.
- ③ Move to the desired system by pressing the [NEXT] button.
- ④ Press the [ADJUST] button to select the desired system.
- ⑤ Press the [MENU] button to exit the adjustment menu.

Highlighted choice will be in green.

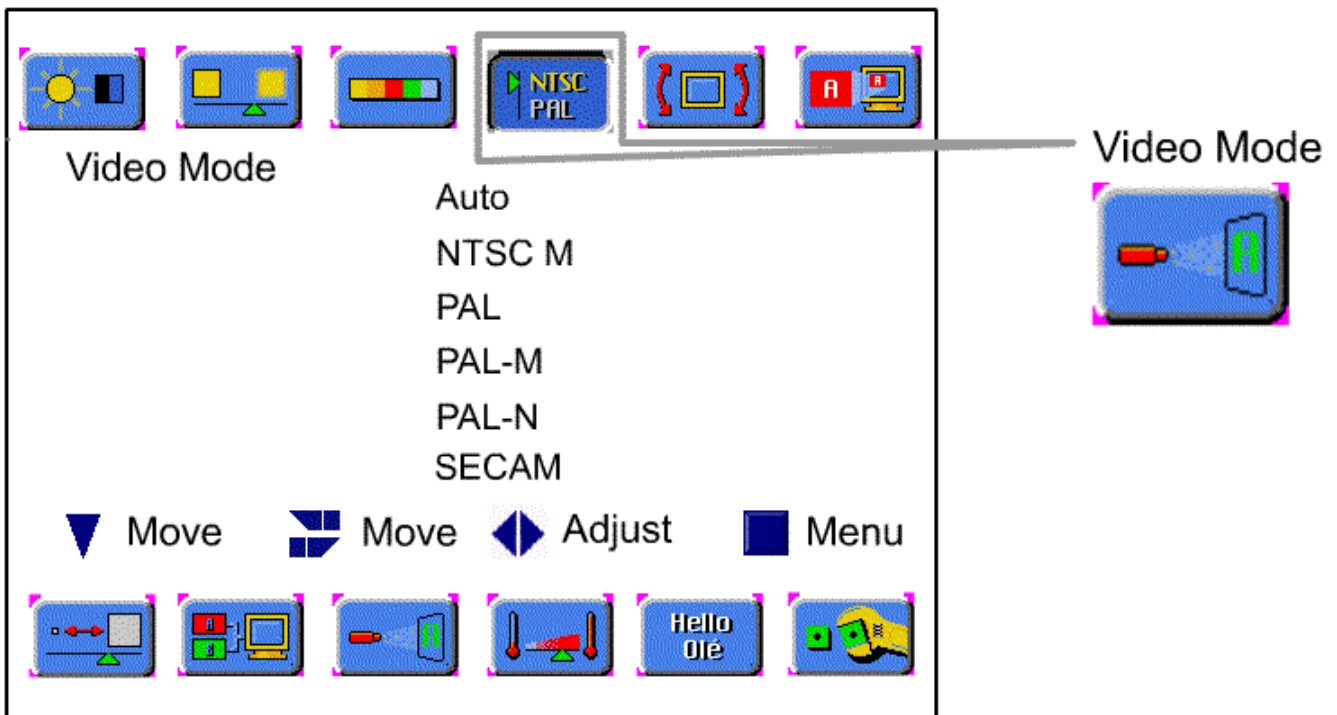

**Auto** : The video signals are automatically detected and the format is set accordingly.

**NTSC M** : This is the standard format used mainly in the United States and Korea.

**PAL** : This is the standard format used mainly in the United Kingdom and Germany.

**PAL-M** : This is the standard format used mainly in Brazil.

**PAL-N** : This is the standard format used mainly in Argentina.

**SECAM** : This is the standard format used mainly in France and Russia.



# Color Temperature

## Color Temperature Setting

Follow these steps for setting the Color Temperature.

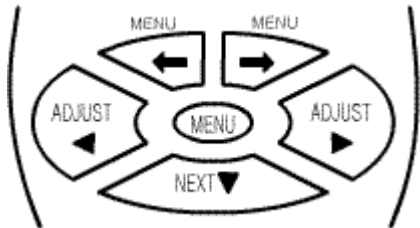

- ① Press the [MENU] button.
- ② Select the Color Temperature by using the [←]/[→] buttons.
- ③ Move to the desired mode by pressing the [NEXT] button.
- ④ Press the [ADJUST] button to select the desired mode.
- ⑤ Press the [MENU] button to exit the adjustment menu.

Highlighted choice will be in green.

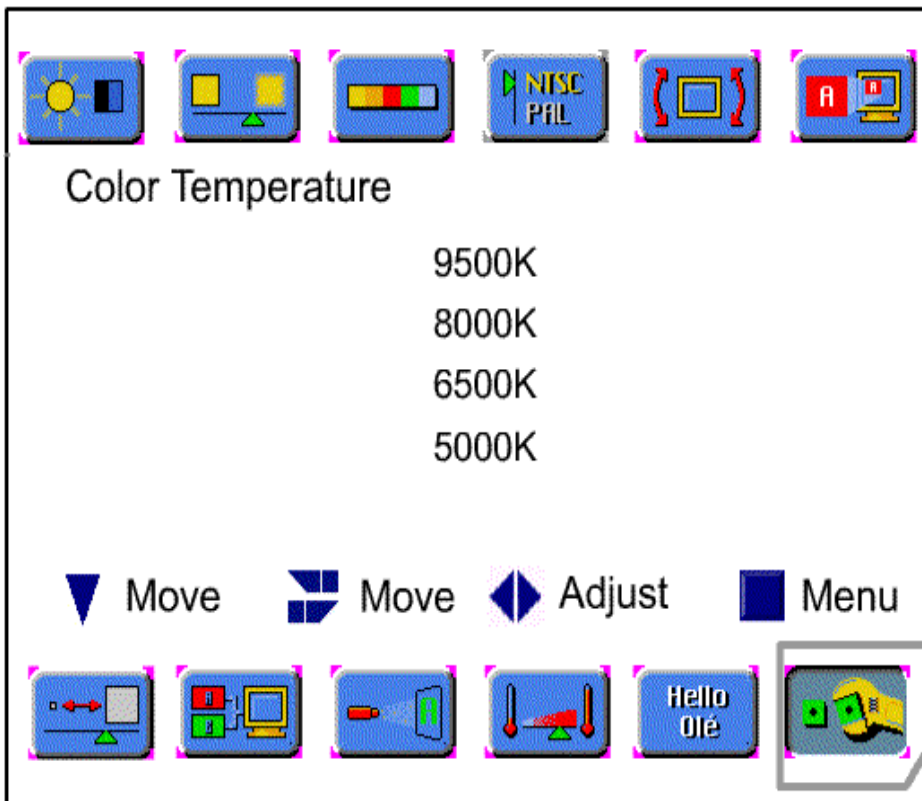

**Color Temperature** : The higher temperature the coolest image looks like.  
The lower temperature the warmest image looks like.

# Specifications

---

Power Source	AC100V~240V, 50/60Hz	
Power Consumption	< 350W (Typical)	
Display Panel	Screen Size	921 mm (H) × 518 mm (V) <42" diagonal>
	Number of Pixels	853(Horizontal) × 480 (Vertical)
	Brightness	550 cd/m <sup>2</sup>
	Contrast Ratio	700:1
	Displayable Colors	16,770,000 Colors
	Viewing Angle	Over 160 degrees
Display Mode	Input Signal	TV, Video, S-VHS, Component, PC
	RF Input System	NTSC(F-Type) or PAL(DIN-Type)
	Video Input System	NTSC, PAL, SECAM
Input/Output	Input	PC (P), PC(S) Video1(V, L, R)/S-VHS Video2 (V, L, R)/SCART Video3 [Component (Y, Pb, Pr), Sound (L, R)] RF IN (NTSC F-TYPE, PAL DIN-TYPE)
	Output	Monitor Out (V, L, R)/ SCART Speaker Out (L,R,Center,Surround L/R,Sub-W), Headphone
Weight	Without Stand	33 Kg
Dimensions	Without Stand	1080 mm (W) × 670mm (H) × 99.5 mm (D)
Operation Condition	Temperature	0° C    40° C
	Humidity	20%    80%
Storage Temperature	-25° C    60° C	

# Troubleshooting

---

Symptom	Cause	Possible Solution
No Power	Power to the TV is not plugged in.	Check source of power to the TV.
Unit will not respond to remote control	Sensor is blocked. Batteries in remote control are weak.	Clear path for sensors. Clean sensor lens. Replace batteries.
No signal is displayed	Video source incorrect.	Check video source connection. Make sure TV is set to correct video source.
Picture scrolls or is fuzzy	Antenna type or location	Change antenna. Try antenna in different location.

# FCC Compliance Statements

---

NOTE : This equipment has been tested and found to comply with the limits for a Class B digital device, pursuant to part 15 of the FCC Rules. These limits are designed to provide reasonable protection against harmful interference in a residential installation.

This equipment generates ,uses and can radiate radio frequency energy and ,if not installed and used in accordance with the instruction , may cause harmful interference to radio communication. However , there is no guarantee that interference will not occur in a particular installation.

If this equipment dose harmful interference to radio or television reception, which can be determined by turning the equipment off and on. The user is encouraged to try to correct the interference by one or more of the following measures :

- - Reorient or relocate the receiving antenna
- - Increase the separation between the equipment and receiver.
- - Connect the equipment into an outlet on a circuit different from that to which the receiver is connected.
- - Consult the dealer or an experienced radio / TV technician for help.

Warning :

Your are cautioned that any change or modifications to the equipment not expressly approved by the party responsible for compliance could void your authority to operate such equipment.

NOTE : This unit was tested with shielded cables on the peripheral device . Shield cables must be used with the unit to insure compliance.