

## 1184 Wireless Carbon Monoxide Detector

### Description

The 1184 is a 3V battery powered wireless carbon monoxide (CO) detector that provides early warning when its electrochemical sensing technology measures carbon monoxide levels in the air.

The detector consists of an electrochemical carbon monoxide sensor assembly coupled with an 1100 Series wireless transmitter. The transmitter can send alarm, trouble, tamper and low battery condition messages to the alarm panel.

The 1184 is an ideal carbon monoxide detector for difficult to wire locations, applications where room aesthetics are critical or where hazardous materials exist.

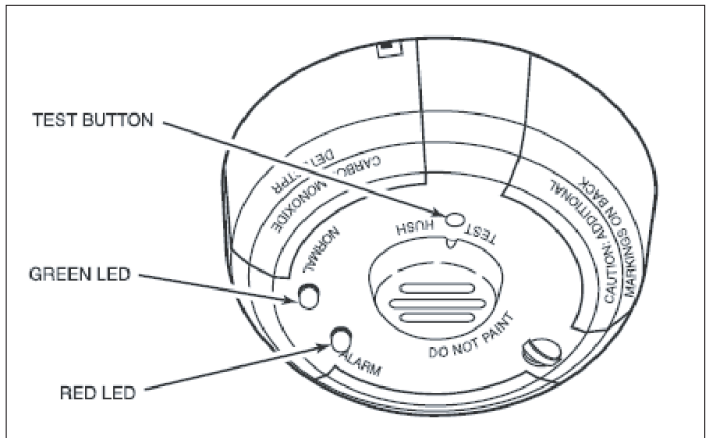

Figure 1: Carbon Monoxide Detector

### Compatibility

All DMP 1100 Series Wireless Receivers and Panels

### What is Included

The 1184 Wireless Carbon Monoxide Detector package includes the following items:

- One 1184 Carbon Monoxide Detector with DMP wireless transmitter installed
- One 3V lithium CR123-Fire battery
- Hardware pack
- Zone name and number label
- Serial number labels

### Transmitter Serial Number

For your convenience, an additional pre-printed serial number label is included. Prior to installing the device, record the serial number or place the pre-printed serial number label on the panel programming sheet. This number is required during programming. As needed, use the zone name and number label to identify a specific transmitter.

### Programming the Transmitter in the Panel

Locate and record the detector serial number. This number is required during programming. Program the device as an Emergency (EM) type zone in **Zone Information** during panel programming. At the Serial Number: prompt, enter the eight-digit serial number. Continue to program the zone as directed in the panel programming guide.

**Note:** When a receiver is installed, powered up, or the panel is reset, the supervision time for transmitters is reset. If the receiver has been powered down for more than one hour, wireless transmitters may take up to an additional hour to send a supervision message unless tripped, tampered, or powered up. This operation extends battery life for transmitters. A missing message may display on the keypad until the transmitter sends a supervision message.

### Transmitted Signal Outputs

The CO detector provides the signals listed in the table:

Signal	Keypad Display
Alarm	ALARM
Low battery	LO BAT
Detector head removed	TROUBLE

## Selecting the Proper Location (LED Survey Operation)

For optimum wireless performance, install the transmitter away from large metal objects. Mounting the transmitter on or near metal surfaces impairs performance. The 1183 Series transmitters provide a survey capability to allow one person to confirm transmitter communication with the receiver. The 1183 transmitter PCB Red Survey LED turns on whenever data is sent to the receiver then immediately turns off when the receiver acknowledgement is received. The survey button is located within the battery compartment and the transmitter survey LED can be seen near the survey button location. When the transmitter does not receive an acknowledgement from the receiver the LED remains on for about 8 seconds to let you know communication is not established. Communication is also faulty when the LED blinks multiple times in quick succession. Relocate the transmitter or receiver until the LED immediately turns off indicating the transmitter and receiver are communicating properly.

Test the communication between the control panel and the detector before permanently mounting the detector as follows:

1. Program the transmitter into the panel. See *Programming Transmitter in the Panel*. Install the battery.  
**Note:** Survey operation requires that the detector have the mounting base installed to engage the tamper switch.
2. Hold the detector up in the location where you plan to install it.
3. Press the survey button (See Figure 2) to send data to the receiver to confirm operation.

## General Location Guidelines

In addition to NFPA 720, use the following location guidelines to optimize performance from the detector:

- Locate ceiling-mounted detectors at least 12 inches from any wall
- Locate wall-mounted detectors at least as high as the light switch and at least 6 inches from the ceiling.
- Mount the detector on a firm permanent surface
- Locate the detector in environmentally controlled areas where the temperature does not exceed 104° F (40° C) or drop below 32° F (0° C).
- When mounting to suspended ceiling tile, the tile must be secured with the appropriate fastener to prevent tile removal
- Locate in the vicinity of flame-fueled appliances, but no closer than 10 feet.
- Keep detectors away from vents and the reach of children and pets.
- Mount the detector on a firm permanent surface

## Installing the Detector

**Note:** When setting up a wireless system, it is recommended to program zones and connect the wireless receiver before installing batteries in the transmitters.

### Install the Mounting Base

1. Using the two screws provided, mount the base in the location previously surveyed for proper communication.

### Attaching and Removing the Detector

1. Using the alignment notch on the lip of the mounting base as a guide, align the detector with the alignment tabs.
2. Insert the detector into the mounting base and turn clockwise approximately 15 degrees. It should snap firmly into place.

To remove the detector from the mounting base, grasp the detector and turn it counterclockwise approximately 15 degrees. The detector should snap off of the mounting base. See Figure 3.

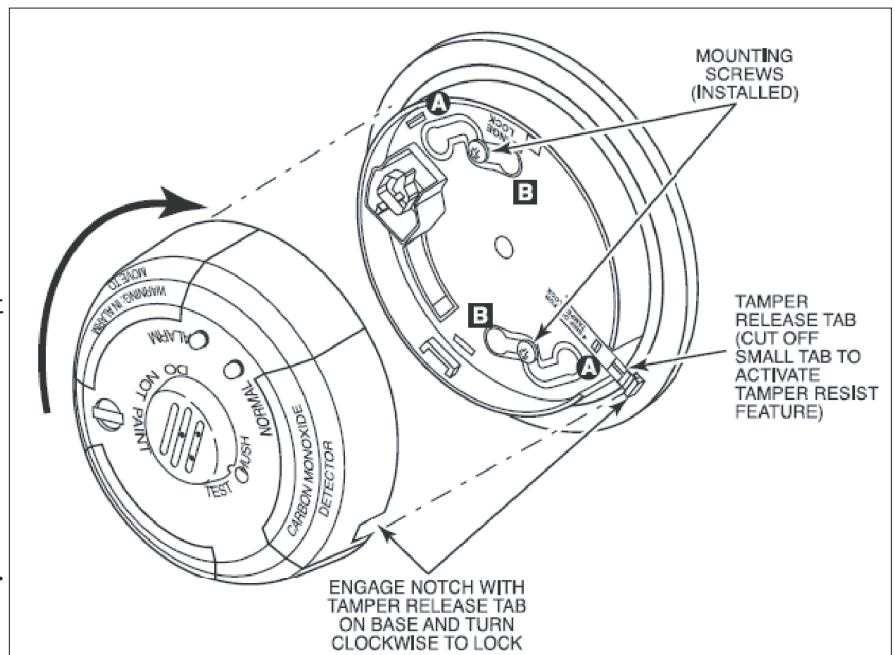

Figure 3: Exploded View of CO Detector

## Installing or Replacing the Batteries

Observe polarity when installing the battery. Use only 3.0V lithium batteries, DMP Model CR123-FIRE or Panasonic Model CR123A-Fire.

**Note:** When setting up a wireless system, it is recommended to program zones and connect the receiver before installing batteries in the transmitters.

1. Remove the detector from the mounting base by grasping the detector and turning it counterclockwise approximately 15 degrees. The detector should snap off of the mounting base.
2. The battery is located on the inside of the cover
2. If replacing the battery, remove the old battery and dispose of them properly.
3. Observing correct polarity, insert the new 3V lithium battery into the battery compartment and replace the cover. Use only new batteries when replacing old ones.
4. Reattach the detector to the mounting base. See *Attaching and Removing the Detector*.
5. Test the detector. See *Testing the Detector*.



**Caution:** Properly dispose of used batteries. Do not recharge, disassemble, heat above 212°F (100°C), or incinerate. Risk of fire, explosion, and burns.

## Testing the Detector Alarm

1. To test the detector alarm, enable Walk Test operation on the control panel. If the system is monitored, the system sends a System Test Begin report (System message S66) to the central station.  
To conduct the Walk Test, reset the control panel by momentarily placing a jumper on J16. From the keypad, enter the code 8144. The keypad displays WALK TEST. Refer to the panel programming guide for complete information on Walk Test operation.
2. For the XTL or XT30/XT50 Series panels, select STD (Standard Walk Test). For the XR100/XR500 Series panels, select FI (Fire zones). A sensor reset occurs after each detector tested.
3. Remove the detector from the mounting base. See *Attaching and Removing the Detector*. Carefully short the two terminals (screw heads) momentarily to send an alarm signal to the control panel. Verify that the walk test trip counter increments to indicate a successful test. Once testing is completed, install the detector back onto the mounting base. Shorting the terminals does not affect the standard operation of the detector.
4. Select END to stop the Walk Test. When the Walk Test ends or a 20-minute time-out expires, a final Sensor Reset occurs. The System Test End message (System message S67) is sent to the central station along with verify and fail messages for each zone under test. Faulted zones then display on the keypad.

**Important:** The control panel alarm and all auxiliary functions should be verified for a complete test of the system. See the panel programming guide for additional information.

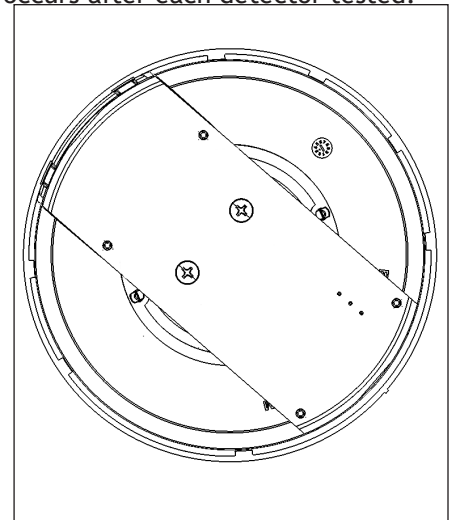

Figure 5: Testing the Detector

## Battery Life Expectancy

Typical battery life expectancy for DMP wireless heat detectors is at least 2 years. DMP wireless equipment uses two-way communication to extend battery life.

The following situations can reduce battery life expectancy:

- If a receiver is unplugged or not installed.
- Frequent transmissions, such as how often the detector is tested.
- When installed in extreme hot or cold environments.

## FCC Information

This device complies with Part 15 of the FCC Rules. Operation is subject to the following two conditions:

- (1) This device may not cause harmful interference, and
- (2) this device must accept any interference received, including interference that may cause undesired operation.

Changes or modifications made by the user and not expressly approved by the party responsible for compliance could void the user's authority to operate the equipment.

**NOTE:** This equipment has been tested and found to comply with the limits for a Class B digital device, pursuant to part 15 of the FCC Rules. These limits are designed to provide reasonable protection against harmful interference in a residential installation. This equipment generates, uses and can radiate radio frequency energy and, if not installed and used in accordance with the instructions, may cause harmful interference to radio communications. However, there is no guarantee that interference will not occur in a particular installation. If this equipment does cause harmful interference to radio or television reception, which can be determined by turning the equipment off and on, the user is encouraged to try to correct the interference by one or more of the following measures:

- Reorient or relocate the receiving antenna.
- Increase the separation between the equipment and receiver.
- Connect the equipment into an outlet on a circuit different from that to which the receiver is connected.
- Consult the dealer or an experienced radio/TV technician for help.

## Industry Canada Information

This device complies with Industry Canada Licence-exempt RSS standard(s). Operation is subject to the following two conditions: (1) this device may not cause interference, and (2) this device must accept any interference, including interference that may cause undesired operation of the device.

Le présent appareil est conforme aux CNR d'Industrie Canada applicables aux appareils radio exempts de licence. L'exploitation est autorisée aux deux conditions suivantes : (1) l'appareil ne doit pas produire de brouillage, et (2) l'utilisateur de l'appareil doit accepter tout brouillage radioélectrique subi, même si le brouillage est susceptible d'en compromettre le fonctionnement.

### Specifications

#### Battery

Life Expectancy 2 years  
(normal operation)  
3.0V Lithium CR123A  
See Battery Life Expectancy for full details.

#### Low battery

Threshold signal 2.40V

Frequency Range 903 - 927 MHz

#### Dimensions

Detector 5.8" x 2.2"  
(14.3cm x 6.1cm)

CO detector specifications:

Color White

### Compatibility

1100D Wireless Receiver  
1100DH Wireless High Power Receiver  
1100DI Wireless In-line Receiver  
1100X Wireless Receiver  
1100XH Wireless High Power Receiver  
XTL Panel with integrated wireless receiver  
XT50 Series panel with integrated wireless receiver

### Patents

U. S. Patent No. 7,239,236

### Listings and Approvals

FCC Part 15 Registration ID: CCKPC0134  
IC Registration ID: 5251A-PC0134  
Underwriters Laboratories (UL) Listed  
ANSI/UL 2034 Single and Multiple Station Carbon  
Monoxide Detectors



800-641-4282

[www.dmp.com](http://www.dmp.com)

Made in the USA

INTRUSION • FIRE • ACCESS • NETWORKS

2500 North Partnership Boulevard

Springfield, Missouri 65803-8877

LT-1196 1.01 © 2011 Digital Monitoring Products, Inc. 11405  
MADE IN U.S.A.