

ATTENTION SYMBOLS, WARNING SYMBOLS, AND GRAY BOXES

You *must* be aware of safety when you install and use this system. This *User Guide* provides various procedures. If you do some of these procedures carelessly, you could *injure* or *kill* yourself or damage equipment or property. Some other procedures require special attention.



The **WARNING!** symbol means that if you are not careful,

You could *injure* or *kill* yourself, or
You could damage equipment or property.



The **ATTENTION!** symbol means you should pay special attention to:

Important instructions for using the system, or
Important instructions for maintaining the system.



The Class II Symbol alerts qualified service personnel to use only identical replacement parts in this apparatus.

FOR YOUR SAFETY



Do *not* try to open the case of the receiver. There is risk of electrical shock, which may cause damage to the receiver and/or personal injury or death to you. There are *no* user-serviceable parts inside the receiver. Opening the receiver case or making unauthorized changes will void the warranty.

To reduce the risk of fire or electric shock, do *not* expose this appliance to rain or moisture.



IMPORTANT SOFTWARE NOTICE!

As with all software controlled products, unexpected behavior could arise if the user tries to perform operations in a non-routine manner. This product, like almost any other high tech product, is subject to bugs and hence EchoStar CANNOT AND DOES NOT GUARANTEE OR WARRANT THAT ALL FEATURES, SUCH AS PARENTAL CONTROL, WILL WORK AS INTENDED UNDER ALL CIRCUMSTANCES. EchoStar endeavors to improve such conditions and will periodically download improvements.

EQUIPMENT AND SOFTWARE COVERED BY THIS USER'S GUIDE

Note: This *User Guide* covers the DISH 111 receiver and software model DP111. This *Guide* may cover other devices, not listed here.

COPYRIGHT NOTICE

Copyright © 2003 EchoStar Technologies Corporation, Englewood, Colorado 80112. All rights reserved.

The information in this *User Guide* may change without notice. We may issue revisions to tell you about such changes.

Please send comments or questions about this *User Guide* to: *Technical Publications, EchoStar Technologies Corporation, 94 Inverness Terrace East, Englewood, Colorado 80112.*

Part Number: 126564

Printed in the United States of America.

DISH Network is a registered trademark of EchoStar Satellite Corporation. For information about DISH Network, please visit our website at www.dishnetwork.com.

We acknowledge all product names, trade names, or corporate names we mention in this *User Guide* to be the proprietary property of the registered owners.

Contents

Safety	v
Introduction	1
Welcome to DISH Network	1
Overview	1
If You Need More Assistance	2
Quick Start Guide	2
About Satellite Television	3
Satellite Signal Quality	3
Parts of the System	5
The Receiver Front Panel	5
The Receiver Back Panel	6
The Remote Control	7
The Menu	11
The Browse Banner	15
Using the System	17
Changing Channels	17
Using the Menu	17
Using the Program Guide	20
Using the Program Banner	22
Using the Browse Banner	22
Ordering Pay Per View Programs	24
Using Themes	25
Using Search	25
Using Favorites Lists	27
Using Timers	29
Using Locks	36
Using Caller ID	44
Restarting the Receiver	46
Resetting the Receiver to Factory Settings	46
Changing Program Languages	46
Testing the Phone Connection	47
Setting Up the Receiver for Channel 3 or 4	48
Installation Instructions	49
How to Use these Instructions	49
Connecting Your TV and VCR	49
Installing a DISH 500 Antenna	50
DishPro Wiring Diagrams	60
Running Coaxial Cable	67
Connecting the Receiver to a Phone Line	68

Reference..... 71
 Troubleshooting Tables 71
 Device Codes 81

Appendix A 83

Appendix B 85
 Limited Warranty 85
 Residential Customer Agreement 87
 Staying Legal 93
 FCC Compliance 93

Index..... 95

Important Safety Instructions

1. Read these instructions.
2. Keep these instructions.
3. Heed all warnings.
4. Follow all instructions.
5. Do not use this apparatus near water.
6. Clean only with a dry cloth.
7. Do not block any ventilation openings. Install in accordance with the manufacturer's instructions.
8. Do not install near any heat sources such as radiators, heat registers, stoves, or other apparatus (including amplifiers) that produce heat.
9. Do not defeat the safety purpose of the polarized or grounding-type plug. A polarized plug has two blades with one wider than the other. A grounding-type plug has two blades and a third grounding prong. The wide blade or the third prong are provided for your safety. If the provided plug does not fit into your outlet, consult an electrician for replacement of the obsolete outlet.
10. Protect the power cord from being walked on or pinched, particularly at plugs, convenience receptacles, and the point where they exit from the apparatus.
11. Use only attachments/accessories specified by the manufacturer.
12. Unplug this apparatus during lightning storms or when unused for long periods of time.
13. Refer all servicing to qualified service personnel. Servicing is required when the apparatus has been damaged in any way, such as the power supply cord or plug is damaged, liquid has been spilled or objects have fallen into the apparatus, the apparatus has been exposed to rain or moisture, does not operate normally, or has been dropped.



Apparatus shall not be exposed to dripping or splashing and no objects filled with liquids, such as vases, shall be placed on the apparatus.

Note to Satellite TV System Installer: This reminder is provided to call the satellite TV system installer's attention to Article 820-40 of the *National Electrical Code* (NEC) that provides guidelines for proper grounding and, in particular, specifies that the cable ground shall be connected to the grounding system of the building as close to the point of cable entry as practical.

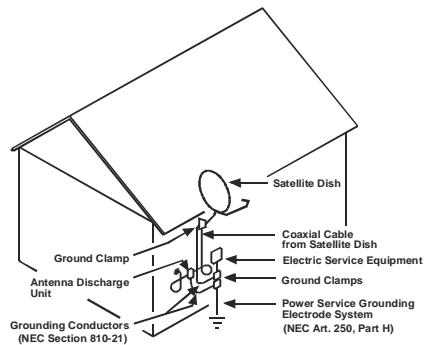

Safety Tips

- Unplug the receiver from the AC power outlet *before* cleaning.
- The use of accessories or attachments not recommended by the receiver manufacturer will void the *Limited Warranty*.
- Do *not* place the receiver in an enclosure such as a cabinet without proper ventilation.
- Do not install the receiver in any area where the temperature can be less than 40°F or more than 113°F.
- Do *not* stack the receiver on top of or below other electronic devices.
- Do *not* place candles or other meltable objects on top of the receiver.
- Operate the receiver using *only* the type of power source indicated on the marking label. Unplug the receiver power cord by gripping the power plug, *not* the cord.
- Do *not* overload wall outlets or extension cords, as this can result in a risk of fire or electrical shock.
- *Never* insert objects of any kind into the receiver through openings, as the objects may touch dangerous voltage points or short out parts. This could cause fire or electrical shock.
- *Make sure* that the outdoor parts of the antenna system are grounded in accordance with local, state, federal, and *National Electrical Code* (NEC) requirements.
- Do *not* locate the antenna near overhead light or power circuits, or where it can fall into such power lines or circuits. When installing the antenna, take *extreme* care to avoid touching such power lines or circuits, as contact with them can be *fatal*.
- Do *not* attempt to service the receiver yourself, as opening or removing covers may expose you to dangerous voltage, and will void the *Limited Warranty*. Refer all servicing to authorized service personnel.
- Use an outlet that contains surge suppression or ground fault protection. For added protection during a lightning storm, or when the receiver is left unattended and unused for long periods of time, unplug the power cord from the wall outlet, disconnect the lines between the receiver and the antenna, and disconnect the telephone line. This will provide some protection against damage caused by lightning or power line surges.

Chapter 1

Introduction

WELCOME TO DISH NETWORK™

Thank you for choosing DISH Network. You are about to experience the excitement and convenience of Digital Broadcast Satellite (DBS) service, which delivers the very best in picture and sound quality. DISH Network consistently provides state-of-the-art, products and satellite-delivered services — with high performance, ease of operation, and a wide variety of entertainment options.

OVERVIEW

Before you use your satellite receiver, you need to install the system or have it installed by a professional technician. For a professional installation, please call the Customer Service Center at 1-800-333-DISH (3474). If you install the system yourself, use the instructions in *Chapter 4*.



A vital part of the installation is to set up the receiver to get the latest software from the satellite signal. If you are installing a new system and follow the instructions in *Chapter 4*, your receiver will automatically get this software.

For information on the system, read *Chapter 2, Parts of the System* beginning on page 5.

For information on any specific feature or function, read *Chapter 3, Using The System* beginning on page 17.

For information on assembling and installing a satellite system, read *Chapter 4, Installation Instructions* beginning on page 49.

If you have a problem operating the system or receive an error message, use the *Troubleshooting Tables* beginning on page 71.

CONVENTIONS USED IN THIS GUIDE

To make it easy for you to use this guide, we use the following conventions:

- The names of remote control buttons and modes are all uppercase. Example: Press the **POWER** button.
- Menus and options that appear on the TV screen are in bold type. Example: Open the **Program Guide**.
- Connections on the back of the receiver are in small capital letters. Example: **SAT IN**
- *Select* means to move the highlight to an onscreen option or choice in a list and press the **SELECT** button on the remote control. Example: Select the **Locks** option.

Tip: Channels that appear in red cannot be viewed because they are not part of your subscription. You can add channels to your subscription simply by calling DISH Network at 1-800-333-DISH.

IF YOU NEED MORE ASSISTANCE

If you need help after you read this guide, call Customer Service at 1-800-333-DISH (3474). You can also call the Customer Service number for information on professional installation.

QUICK START GUIDE

After your system has been installed, order and watch your programming using the following steps:

STEP 1: ORDERING YOUR PROGRAMMING

1. If the receiver is off, press the blank **POWER** button on the remote or press the **POWER** button on the receiver.



2. Press **GUIDE** on the remote control.



You will see that some channels appear in white. These channels can be viewed immediately. However, many channels will be in red. You cannot view these channels until you order programming.

TO ORDER PROGRAMMING

1. Display the **Important System Information** screen on your TV by pressing **SYS INFO** on the remote.



Note: You can also display the **Important System Information** screen by turning off the receiver and pressing either the **UP** or **DOWN ARROW** button on the receiver front panel.



2. Call the Customer Service Center at 1-800-333-DISH (3474). A customer service representative will help you with your system and will discuss the various programming packages available.
3. Choose a package and the representative will authorize your programming.
4. Wait a few minutes and the channels you purchased will turn from red to white, and can now be viewed.

STEP 2: FINDING PROGRAMS TO WATCH

First, make sure the receiver is turned on. Press the **POWER** button on the remote or press the **POWER** button on the receiver. There are two ways to find information on programs.

- Press the **GUIDE** button. When the **Program Guide** opens, use the **UP** or **DOWN ARROW** to view information on other channels. After you have highlighted a program in the **Program Guide**, press **SELECT** to watch it.



Note: The **Program Guide** provides a complete listing of all programs available on all channels, including those that are not in your subscription (these channels have red backgrounds).

- While viewing a program, press the **BROWSE** (**RIGHT ARROW**) button. Then press either the **UP** or **DOWN ARROW**. The information on other channels will appear in the **Browse Banner** at the bottom of the screen. Press **SELECT** to watch the program.



Tip: The system automatically displays programs based on the current day and time. You can advance the Guide to view information on future programs, but not programs that have already ended.

ABOUT SATELLITE TELEVISION

Satellite television uses a satellite in a stationary orbit over the Earth to deliver television and audio programming. This type of orbit enables the satellite to stay aligned over one place on the surface of the Earth.

Once the satellite dish is aimed at the satellite, the dish does not have to move to follow it.

SATELLITE SIGNAL QUALITY

RAIN AND SNOW FADE

Heavy rain, snow, or cloud cover can block the satellite signal, which can interrupt your programming service. By aiming the satellite dish to get the strongest signal during installation, you can help prevent rain and snow from interrupting the signal. Your service will return after the weather condition has passed.

Tip: If you lose your picture, it's most likely due to heavy rain, snow or snow build-up on your dish.

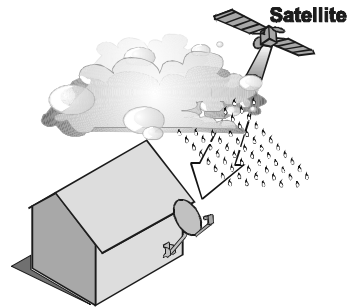

SOLAR INTERFERENCE

Twice a year, the sun moves to a position behind the DISH Network satellite as it orbits the Earth. The exact time of the year that this occurs varies, depending on the location, but it is near the beginning of spring and again near the beginning of autumn. The period of solar interference lasts for a few minutes at about the same time everyday for a few days during the spring and autumn, so do not be alarmed when it happens.

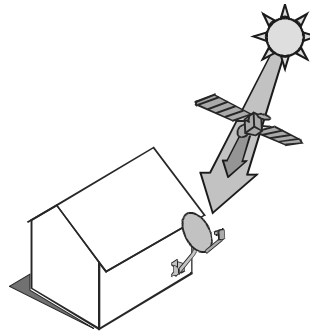

This is an unavoidable natural event for all television involving the use of satellites and has an adverse effect on many program providers. During this period, you will not be able to see programs on DISH Network. Once the sun has moved from behind the satellite, the programs will reappear.

Chapter 2

Parts of the System

THE RECEIVER FRONT PANEL

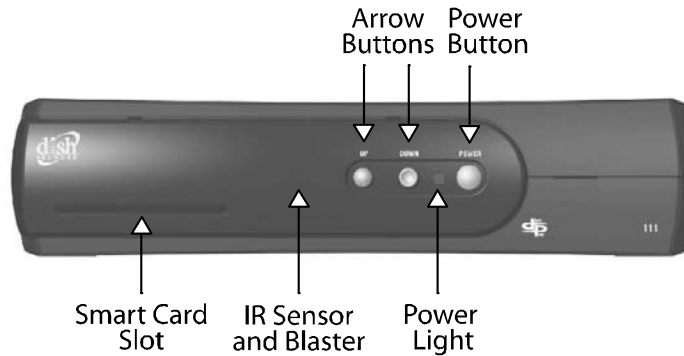

SMART CARD SLOT

This slot is for a future Smart Card. No Smart Card is included with this receiver.

UP AND DOWN ARROW BUTTONS

The UP and DOWN buttons change the channel on the receiver.

Note: You can display the **Important System Information** screen by turning off the receiver and pressing either the UP or DOWN ARROW button on the receiver front panel.

IR SENSOR AND IR BLASTER

The IR Sensor receives IR signals from the remote control. For information on the IR Blaster, see page 35, *Setting Up the Receiver to Control the VCR*.

POWER BUTTON AND LIGHT

The POWER button turns the receiver on and off. The light indicates that the receiver is on.

Note: If your receiver stops responding to the remote control and front panel commands, press and hold the front panel POWER button for about 4 seconds. When you release the button, the receiver will reset.

THE RECEIVER BACK PANEL



The back panel of the receiver provides the connections that you use to connect the receiver to other electronic devices. It also provides the receiver power cord and telephone jack. Depending on the setup that you use, you may only use some of these connections. For information on wiring and wiring diagrams, see the installation instructions in *Chapter 4*.

COAXIAL CONNECTIONS

The three coaxial connections on the back of your receiver are color coded. When you install your receiver or if you ever have to move it, the color coding will make it easier for you to connect the cables to the back of your receiver. Inside the front cover of this guide are stickers that are color coded the same way as the coaxial connections. See *Chapter 4* for instructions on connecting your receiver to other electronic devices using coaxial cables.

Tighten the coaxial cable connections only by hand.

Tip: Using cable labels makes it easy to tell which cables connect to the right receiver ports.

Tip: If you have the receiver connected to a DSL (Digital Subscriber Line) phone line and it cannot dial out, you may have to install a DSL filter between the receiver and the telephone jack on the wall.

SATELLITE IN

Connect the coaxial cable between the satellite dish and the receiver using this input. The **SATELLITE IN** connection is color coded blue.



TV SET OUT

Connect the coaxial cable between the receiver and TV using this input. The **TV SET OUT** connection is color coded white.



TV ANTENNA/CABLE IN

If you connect a cable TV box or a broadcast TV antenna to the receiver, use the back panel **TV ANTENNA/CABLE IN** connection for the local signal. The **TV ANTENNA/CABLE IN** connection is color coded black. See *TV/Video Button* on page 8 for information on how to use this input.

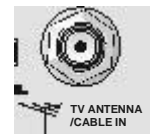

TELEPHONE JACK

Connect a telephone cable with a standard RJ-11 telephone connector to the receiver here, and then connect the cable to an active telephone line.



Note: The receiver *must* be connected at all times to an active telephone line. If you install two or more receivers, each receiver *must* be connected at all times to an active telephone line.

THE REMOTE CONTROL

This section describes the remote control and how to use the buttons to operate the satellite receiver.

If you lose or damage the remote control, you will not be fully able to control the receiver. If this happens, call the Customer Service Center at 1-800-333-DISH (3474) to order a replacement.

Note: This remote control shown here is for example only. The remote that came with the receiver may look slightly different.

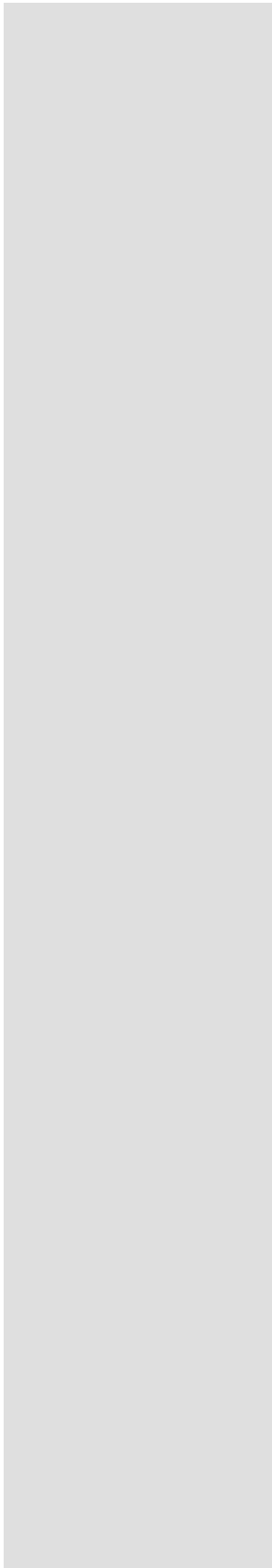

REMOTE CONTROL BATTERIES

The remote control comes with AAA batteries. When you replace old batteries, you should replace *all* of the batteries. Use batteries of the same kind, *for example* alkaline or carbon zinc, and *don't* mix batteries of different kinds. Alkaline batteries last longer.

1. Press down on the top of the battery cover and slide the cover off.
2. Take out all of the old batteries.
3. Put the new batteries in. Make sure you match the plus (“+”) ends with the plus markings inside the battery case.
4. Fit the battery cover’s bottom tab back into the slot at the bottom of the battery case, and slide the cover back into place.

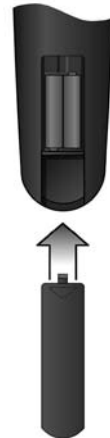

USING THE REMOTE CONTROL

The following section describes how to use the remote control with your satellite receiver.

POWER BUTTONS

Press the POWER button to turn the receiver ON or OFF.



TV/VIDEO BUTTON

Use this button to switch the receiver between the satellite programming and another video signal connected into the receiver’s **TV ANTENNA/CABLE IN** input, such as cable or broadcast TV antenna input.



MENU BUTTON

Press this button to open the **Main Menu**.



PAGE UP AND PAGE DOWN (ARROW) BUTTONS

Press the PAGE UP button or the PAGE DOWN button to scan, page by page, through the **Program Guide**, a **Theme Categories** list, a **Favorite List**, an **Event Timers** list, or a list of channels.



VOLUME BUTTON

Press the minus (-) side of this button to lower the receiver sound. Press the plus (+) side of this button to raise the receiver sound. When you press the VOLUME button, a bar displays on the TV to show you the receiver volume.



MUTE BUTTON

Press this button to turn off the receiver sound. Press it again to restore the receiver sound.

MUTE



To use the VOLUME and MUTE buttons with the receiver:

1. Press MENU.
2. Select **System Setup**.
3. Select **Volume Control**.

MENU



6

7



4. Select **DISH remote volume control**.
5. Select **Save**.

GUIDE BUTTON

Press the GUIDE button to open the **Program Guide**. When the **Program Guide** is open, press this button to switch among **Favorite Lists**.

GUIDE



Tip: The arrow buttons can be used to quickly navigate through menus and the program guide. When you find a program or menu option you would like to access, just press **SELECT**.

Tip: To open some of the menus, use the matching buttons on the remote control. For example, press the **LEFT ARROW** button to quickly open the **Themes Menu**.

Tip: You can quickly change channels by using the **NUMBER** buttons on the remote. Just enter the numbers for the channel you would like to view next.

UP/DOWN/LEFT/RIGHT (ARROW) BUTTONS

- When using a menu, press these buttons to move the highlight to an option.
- When watching a program, press the **RIGHT ARROW** button to open the **Browse Banner** or the **UP** or **DOWN ARROW** button to change channels.
- When the **Browse Banner** is open, press the **UP** or **DOWN ARROW** button to see the **Browse Banner** for the next channels.

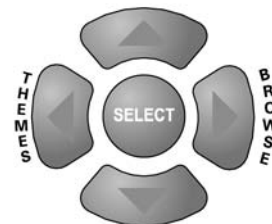

Note: The **Browse Banner**, like the **Program Guide**, shows information on current and future programs. It cannot show information on programs that have ended.

- When a menu offers a list of choices, press the **UP** or **DOWN ARROW** button to see more choices.
- When the **Program Guide** is open, press these buttons to move the highlight among the programs.
- When the **Browse Banner** is open, press the **RIGHT** or **LEFT ARROW** button to obtain information on the next program that will be on that channel.
- When watching a program, press the **LEFT ARROW** button to open the **Theme Categories** menu.

SELECT BUTTON

Press the **SELECT** button to select a highlighted option or program in a menu.



NUMBER BUTTONS

When watching a program or with the **Program Guide** open, use these buttons to enter a channel number to change to that channel.

- When the **Program Guide** is open, you can skip ahead and then back a number of hours. Just enter the number you want to skip ahead (or back), and then press the **RIGHT** (or **LEFT**) **ARROW** button.
- Use these buttons to enter menu option numbers instead of highlighting the option and then pressing the **SELECT** button.
- Use these buttons to enter numbers in a menu:
 - Highlight the place where you want to enter the first number, and press the appropriate number buttons on the remote.

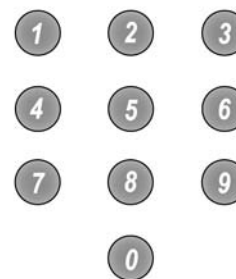

- Use the LEFT or RIGHT ARROW button to move the highlight to the next place where you want to enter a number. When you are done entering numbers, press SELECT.

RECALL BUTTON

Press the RECALL button to return to the last channel you were watching. Press it again to switch between the last two channels that you watched.



INFO BUTTON

Press this button for more information when the **Program Guide** or the **Browse Banner** is open, or when watching a program.



- When a menu is open that includes a **Help** option, press this button to see help information for that menu.
- Highlight a program in a **Theme Categories** list and then press this button for more information on that program.

VIEW TV BUTTON

Press this button to return to watching a program.



- If you are watching a program, press this button to briefly display the **Program Banner**.
- While using any menu, press this button to cancel a procedure and return to watching a program.

CANCEL BUTTON

Press this button to cancel a procedure and to return to the previous menu or to watching a program.



SYS INFO BUTTON

Press this button to open the **Important System Information** screen.



THE MENUS

The next few pages describe the menus that the receiver displays on the television screen. See the chapter titled *Using the System* for more details on using the menus to operate the system.

Tip: When you're in the Program Guide, a Theme Category or a Favorites List use the Information button to get a description of the program, the names of the actors, and other important details.

MAIN MENU

The **Main Menu** is the key to the menus. Each option on this menu displays another menu.



PROGRAM GUIDE

The **Program Guide** lists the available channels and programs. It also has a one-quarter screen video window option that shows the last program you were viewing.

GUIDE



Tip: Love sports or movies? Choose one of these themes and the system immediately displays a list of all programs on at the current time that fit the selected category. See page 25 for details.

THEME CATEGORIES MENU

The **Theme Categories** menu allows you to choose programs based on their contents. This menu also includes a search feature.



FAVORITES LISTS MENU

The **Favorites Lists** menu allows you to create, change, and activate lists of favorite channels.



Tip: This menu is where you set up lists of your favorite channels. For details on setting up these lists, see page 27.

PARENTAL AND SYSTEM LOCKS MENU

The **Parental and System Locks** menu allows you to set and use locks.

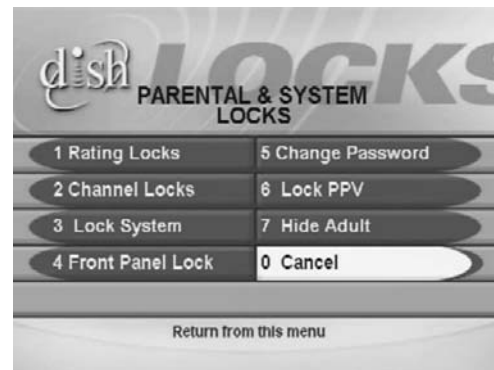

Tip: Want to keep your kids from watching certain channels or programs? Here's where you can set locks to keep them out. For complete details, see page 36.

SYSTEM SETUP MENU

The **System Setup** menu provides several features that help you set up and maintain the system.



Tip: This menu lets you set timers to remind you when that important program is on. You can also set timers to videotape events. See page 29 for complete details.

TIMERS MENU

The **Timers Menu** allows you to set up the receiver to tune in a future “event,” that is, a program. If you have a VCR connected to the receiver, you can set up a timer to start recording a program on the VCR.

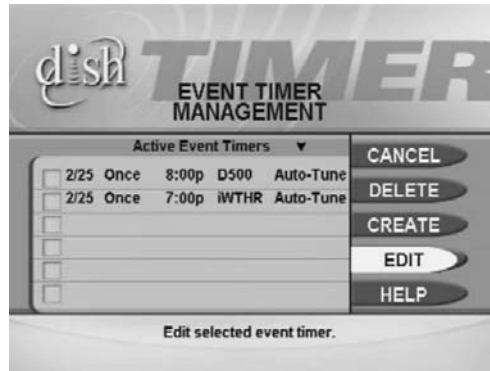

DISH HOME

With **Dish Home**, you can order channels, check the news and weather, and even play games.



CUSTOMER SUPPORT

The **Customer Support** menu provides convenient access to your DISH Network account to review your statement, pay your bill, upgrade programming, and more.



THE BROWSE BANNER

You can use the **Browse Banner** (press the RIGHT ARROW on the remote control) to change channels, or to see what other programs are available without changing the program that you are watching. The receiver displays information on the program you are watching at the top of the screen and **Browse Banner** information at the bottom of the screen.



Note: Your **Browse Banner** may look a bit different than the one shown here.



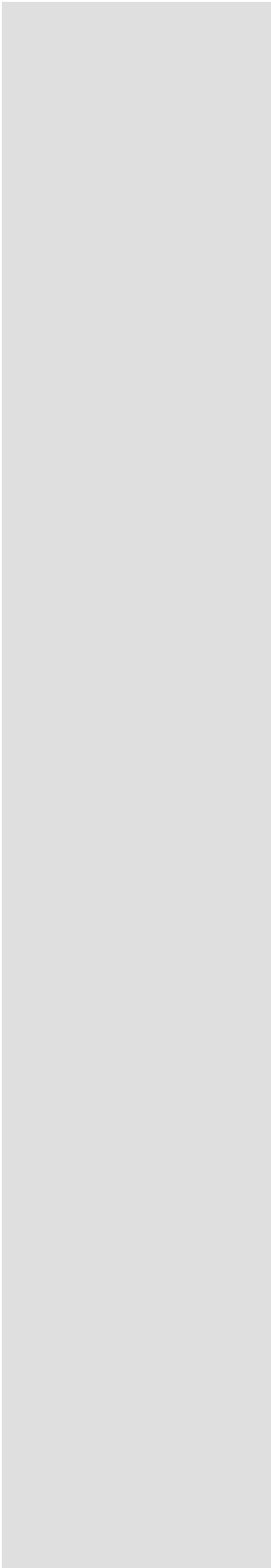

Notes

Chapter 3

Using the System

CHANGING CHANNELS

There are three basic ways to change channels while watching a program:

- Press the remote control **UP** or **DOWN ARROW** button to get to the desired channel.
- Use the remote control number pad buttons to enter the desired channel number.
- Press the **GUIDE** button and select a program from the **Program Guide**. See page 20 for more information.



USING THE MENUS

Menus displayed on the TV screen make using the receiver and selecting programs quick and easy. Use the menus to control the receiver and to use its features, such as setting locks, choosing a program, or creating a **Favorites List**.

OPENING THE MENUS

You can open the menus in either of two ways:

- Press **MENU** to open the **Main Menu**, then select any of the other menus from the **Main Menu**.
- Use the matching button on the remote control. For example, to open the **Program Guide**, press **GUIDE**.

CLOSING THE MENUS

To close a menu and return to watching a program, press the remote control **VIEW TV** button, or the remote control **CANCEL** button.

Note: The menu closes if you do not do anything in a menu for several minutes. Any unsaved changes you made will be lost.

MENU OPTIONS

A menu option looks like this.



Tip: To quickly go to any menu option with a number next to it, just press the numbers on the remote that match that number.

HIGHLIGHTING A MENU OPTION

To highlight a menu option, use the remote control **ARROW** buttons to move the on-screen highlight to the menu option. When you do this, the option appears lighter than the other options. The highlight is like the one that you may have seen on a computer screen.

Compare the highlighted menu option with the non-highlighted menu option in the previous example.



1 PROGRAM GUIDE

SELECTING A MENU OPTION

When you select a menu option, that option takes effect right away. You can select a menu option in either of two ways:

- If the option has a number next to it, press the number on the remote control number pad that matches this number. If you do this, you do not need to highlight the option first.
- Move the highlight to the menu option using the remote control **Arrow** buttons. Then press the remote control **Select** button.

LISTS OF CHOICES IN THE MENUS

*When you make a choice in a list, the receiver does not apply the change until you select the **Save** or **OK** option. If you do not want to save any changes, select the **Cancel** option to discard all the changes made in the menu.*

There are two types of lists:

- A **single choice** list allows you to select *only* one choice at a time. If you select another choice, your previous choice is deselected.
- A **multiple choice** list allows you to select more than one choice at one time. If you select another choice, your previous choice(s) stays selected.

HIGHLIGHTING A CHOICE IN A MENU LIST

Use the remote control **ARROW** buttons to move the highlight to the desired item in the list. The black arrows on the list show where you can move the highlight.

SELECTING A CHOICE IN A MENU LIST

To select a choice in a list, highlight the choice and then press the remote control **SELECT** button. Make sure you select the **Save** or **OK** option to save your choice. Select the **Cancel** option to discard your choice.

When you highlight a choice in a single choice list, it looks like this. In this *example*, the **Spanish** option is highlighted.



When you highlight a choice in a multiple choice list, it looks like this. In this *example*, the **LIFE - 108** option is highlighted.

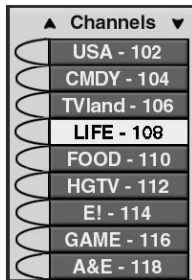

When you select a choice in a list, it looks like this:

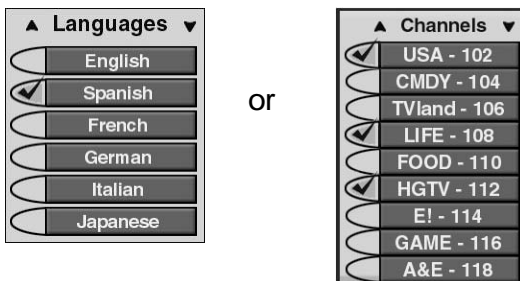

CANCELING A PROCEDURE

To cancel a procedure, you *must* press the remote control CANCEL or VIEW TV button *before* you do the last step of the procedure. If this does not work, you *must* finish the procedure.

Tip: You can cancel out of any menu option or the program guide at any time, and *immediately return to viewing a program* by pressing the VIEW TV button.

Tip: The channel you select may display one of several program information symbols. If the program is on a channel that is not part of your subscription, the channel will be in red.

USING THE PROGRAM GUIDE

The on-screen **Program Guide** provides a complete listing of the available channels and programs. You can use the **Program Guide** to change channels, to see what programs are scheduled, and to buy pay per view programs. The **Program Guide** shows which **Favorites List** is active.



- The **Program Guide** displays only the channels in the active **Favorites List** (see page 27).
 - **All Chan** - Displays all of the channels in the **Program Guide**.
 - **All Sub** - Displays the channels in your subscription.
 - **Favorites Lists** - You can add four **Favorites Lists** that show only the channels you want to see. For more information on creating Favorites Lists, see page 27.
- This receiver allows you to see the program you are watching in a corner of the **Program Guide**. To do this, open the **Main Menu**. Then, select the **System Setup** option. Finally, select the **Guide Displays** option, select the **Partial Guide With Video** option. If you prefer a bigger guide (with no video displayed), select the **Full Guide Without Video** option, and select the **Save** option. When you first display the inset, there may be a brief delay before a picture appears.
- A *red* background behind a channel shows that you have not subscribed to that channel. You *cannot* tune in to this channel.
- The **Program Guide** shows programs that are on now and that are scheduled up to two days in advance. The guide does *not* show programs that have ended. You can set up the **Program Guide** to list channels in *ascending* order, with the highest channel number at the top, or in *descending* order, with the highest channel number at the bottom. To do this, open the **Main Menu**. Then, select the **System Setup** option. Finally, select the **Channel Order** option, select the **Ascending** or **Descending** option, and select the **Save** option.
- You can set up the **Program Guide** to hide adult channels. See *Hiding Adult Channels* on page 42.

OPENING THE PROGRAM GUIDE

There are two ways to open the **Program Guide**:

- Press the **GUIDE** button.
- Press the **MENU** button and then select the **Program Guide** option.



SELECTING A PROGRAM IN THE PROGRAM GUIDE

1. Use the **NUMBER PAD** buttons to enter the desired channel number. The **Program Guide** displays a block of channels including the one that you just entered.
2. Use the **ARROW** buttons to move the highlight to the desired program.

Note: You may press the **PAGE UP** or **PAGE DOWN ARROW** button to scan, page by page, through the listing of channels.

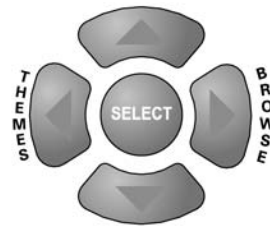

3. You may press the **INFO** button for more information about the highlighted program. Press the **CANCEL** button to return to the **Program Guide**.
4. Press the **SELECT** button to change to the new channel.



You may skip the **Program Guide** forward or backward many hours at one time. To do this, enter the number of hours that you want to skip using the **NUMBER PAD** buttons. Then press the **LEFT** or **RIGHT ARROW** button to move back or forward, respectively.

CLOSING THE PROGRAM GUIDE

To close the **Program Guide** and not change the channel, press the remote control **CANCEL** or **VIEW TV** button. The receiver displays the program you were watching before you opened the **Program Guide**.

Tip: The **Program Guide** can display programs scheduled for some time beyond the present, but cannot display programs that have ended.

USING THE PROGRAM BANNER

The **Program Banner** provides information about the program you are watching. The receiver displays the **Program Banner** for a few seconds at the top of the TV screen every time you change the channel or press the remote control **VIEW** button.



USING THE BROWSE BANNER

Tip: You can use the **Browse Banner** to see what other programs are available without leaving the program you are watching.

You can use the **Browse Banner** to change channels, or to see what other programs are available without changing the program that you are watching. The receiver displays information on the program you are watching at the top and **Browse Banner** information at the bottom of the TV screen. Press the **UP** or **DOWN ARROW** to see what programs are playing on the channels above or below the one you are viewing. Information on these programs appears at the bottom of the TV screen.

Note: The **Browse Banner** only displays the channels in the active **Favorites List** that is indicated in the **Browse Banner**. For example, if the **All Chan Favorites List** is active, the **Browse Banner** displays all the channels. If the **All Sub** list is active, the **Browse Banner** displays only the channels in your subscription.

If you have set up the **Program Guide** to hide adult channels and the receiver is locked, the **Browse Banner** does *not* display such channels.

To use the **Browse Banner**:

1. Press the remote control **RIGHT ARROW** button to open the **Browse Banner** for the program that you are watching.





2. Change the channel:

- Enter the channel number for the program that you want, using the NUMBER PAD buttons
- Press the UP or DOWN ARROW button to display the channel that you want.



3. Press the RIGHT ARROW button to display the next program. Press the LEFT ARROW button to return to the current program.



Note: The **Browse Banner** displays programs that are on now. If you press the RIGHT ARROW, it will display information on the program that is on next on the same channel. It does not display information for any other programs in the future and cannot display programs that have ended.

4. You may press the INFO button for more information about the program highlighted.



5. Press the SELECT button to change to the highlighted program.



6. To close the **Browse Banner**, press the remote control CANCEL button. The receiver stays tuned to the program you are watching.



Tip: If the program is on some time in the future, the receiver will open the Create An Event Timer menu.

Tip: If any lock is in effect that covers the pay per view program, you must enter the password using the **NUMBER PAD** buttons. As soon as you enter the fourth digit of the password, the receiver highlights the **OK**.

ORDERING PAY PER VIEW PROGRAMS

1. Highlight the desired pay per view program in the **Program Guide**. The pay per view programs are listed with the channel number as **PPV** in the **Program Guide**.

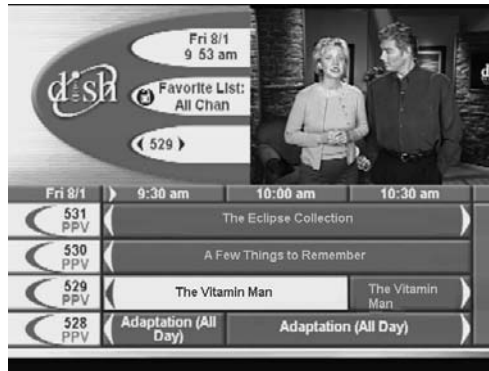

2. Press the **SELECT** button.
3. To buy the pay per view program, select the **Yes** option. The receiver displays a *confirmation* menu. Go on to step 4.

If you do not want to buy the pay per view program, press the **UP** or **DOWN ARROW** button or select the **No** or **Cancel** option.

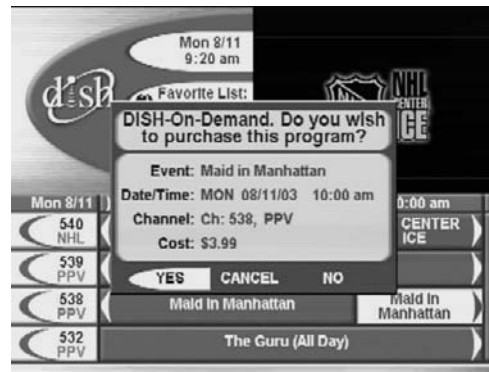

At the *confirmation* menu:

4. Select the **Yes** option to *confirm* the purchase. The pay per view fee will be added to your bill.
Select the **No** or **Cancel** option to *cancel* the purchase.

Note: Once you *confirm* an order for a pay per view program, you *cannot* cancel the order and you will be billed for it.

USING THEMES

THEMES

You can list and choose programs by the theme of their contents (for example, just movies or just sports). You can then quickly list programs based on that theme, and choose the program you want.

1. To open the **Themes** menu, press the **LEFT ARROW** button or press **MENU** and then select **Themes**.



2. Move through the Themes menu by using the **UP** or **DOWN ARROWS**. You can also move a page at a time using **PAGE UP** or **PAGE DOWN**.
3. Highlight the desired program in the program list.



4. Press the **SELECT** button to watch the program.

Note: If the program you highlighted is on some time in the future, the receiver will open the **Create An Event Timer** menu. See page 29 for information on using timers.



Tip: Want to see what movies or sports events are available for viewing? Just press the LEFT ARROW button (THEMES button) and use the up/down/left/right arrows to move to the theme that interests you. Press SELECT and you'll see what's playing.

USING SEARCH

The **Search** feature of your satellite receiver makes it easy for you to find the programs you want to watch.

1. Press **MENU-2-9** on the remote control.
2. The **Search** menu will open.



3. Move the highlight to the **Name** box.
4. There are two ways to enter the name of the program you want to find:
 - Use the **UP**, **DOWN**, **LEFT**, and **RIGHT ARROWS** to scroll around on the virtual keyboard and then select the letters you want.
 - Some remote controls have telephone-style letters above the buttons on the **NUMBER PAD**. Use the remote control **NUMBER PAD** buttons to enter the letters in the **Name** box. To enter an **H**, for example, press 4 twice because H is the second letter listed above the 4 on the **NUMBER PAD**. For example, if you are searching for *Rudy Fremmel Presents*, enter the first few letters in the title as follows:

Press  three times for an **R**.

Press  twice for a **U**.

Press  once for a **D**.

Press  three times for a **Y**.

Note: Enter up to 14 characters (letters and spaces) for your search.

5. When you have entered the name, scroll down to choose between two options:

Search Event Titles Only - Select this option when you are sure the word(s) you entered are part of the event title.

Search All Event Info - Select this option if you want to search event titles and information for the word(s) you entered.

6. Select the **Search** option. When the search completes, you will see a screen listing the name of the program(s) and the start and stop times.



7. Highlight the program you want to watch and press **SELECT**.
8. If the program occurs in the future, the **Create An Event Timer** menu opens. Select **Create** to record the program. See *Using Timers* on page 29 for more information.

USING FAVORITES LISTS

Favorites Lists allow you to display only your favorite channels in the **Program Guide**. You can create and change the lists yourself, adding and removing channels as you wish. You can have an unlimited number of favorite channels but they must be grouped into no more than four lists.

- When you make a **Favorites List** active, the **Program Guide** displays *only* the channels in that list. Also, the receiver skips channels that are not on the list when you use the remote control **UP** or **DOWN ARROW** button to change channels.
- The **All Chan Favorites List** contains all the channels. You *cannot* make any changes to the **All Chan** list.
- The **All Sub Favorites List** contains all the channels in your subscription. You *cannot* make any changes to the **All Sub** list, except by changing your subscription.
- Each **Favorites List** has a unique color in the **Program Guide**. You can give each list a name. When you first get the receiver, the four lists are named **List 1**, **List 2**, **List 3**, and **List 4**. The lists are empty until you add channels to them.

CREATING OR CHANGING A FAVORITES LIST

You can create, add channels to, and remove channels from, a **Favorites List**.

1. Press the **MENU** button.
2. Select the **Favorites** option.



Tip: Favorite lists let you create lists of your favorite channels. Press the **GUIDE** button until the name of your list appears. This way you can quickly see what programs are playing on just those channels and not every channel in your subscription.

Tip: You can activate a Favorites List only if you have added channels to the list. If you have not created any Favorites Lists, pressing the GUIDE button switches the receiver between the All Chan and All Sub.

3. Select the **Favorites** List that you want to create or change.
4. Select the **Modify List** option.

Note: At any time you can select the **Clear List** option to remove all channels from the current list. This does *not* apply to the **All Chan** and **All Sub**.

5. In the **Channels** list, highlight a channel you want to add to the **Favorites List**.

Note: You can use the number pad buttons to enter the channel number, or select the **PAGE UP** or **PAGE DOWN** option to move quickly through the list.



6. Press the **SELECT** button to add the highlighted channel to the **Favorites List**. A check mark appears next to the channel.



7. Repeat steps 5 and 6 until you have added all the channels that you want.
8. To delete a channel from the **Favorites Lists**, select the channel in the list. The check mark next to the channel disappears.
9. Select the **Save** option to save all changes to the **Favorites List**.

MAKING A FAVORITES LIST ACTIVE

If the **Program Guide** is open, press the **GUIDE** button to select the next **Favorites List**. Press the **GUIDE** button again to scan through all the available lists.

CHANGING THE NAME OF A FAVORITES LIST

1. Press the **MENU** button.
2. Select the **Favorites** option.
3. Select the **Favorites List** that you want to change.



- Select the **Edit List Name** option to open the virtual keyboard.



Note: You *cannot* change the name of the **All Chan** or **All Sub** list.

- Select a letter in the keypad area on the screen. Repeat to spell out the desired name. You can enter up to eight characters, including spaces. If needed, select the **space** option to insert a space in the name or the **<back** option to correct a letter.

Note: A list *must* have at least one character. Two lists *cannot* have the same name.

Note: At any time, you can select **Clear** to clear the name.

- Select **Save**.

USING TIMERS

Event timers allow you to set up the receiver to automatically change to a channel and send a signal to a VCR to record a future “event,” *that is*, a program. You can set an *automatic* event timer for a program listed with start and stop times in the **Program Guide**. A *manual* event timer allows you to set custom start and stop times for a timer.

EVENT TIMER TYPES

Reminder Reminds you that a program is about to start.

Auto-Tune Reminds you that a program is about to start; tunes the receiver to the program when it begins.

VCR Reminds you that a program is about to start; tunes the receiver to the program when it begins; starts a VCR to record the program. See *Setting Up the Receiver to Control the VCR* on page 35.

Note: Most TV programs and films are copyrighted. In some cases, copyright law may apply to private, in-home recording.

Tip: If you try to make an empty Favorites Lists active, the receiver displays an Error message. You must add at least one channel to this Favorites List before you can make it active.

Tip: You can use an Auto-Tune event timer to remind you that a program is about to start and then automatically tune the receiver to the right channel.

EVENT TIMER FREQUENCIES

Once Applies to a one-time program. If the program time changes, this timer operates at the *new* time. The receiver *deletes* this timer when the timer operates.

Mon.-Fri. - Applies to a program that is scheduled for Monday through Friday on the same channel at the same time each day.

Daily - Applies to a program that is scheduled for Monday through Sunday on the same channel at the same time each day.

Weekly - Applies to a program that is scheduled for once a week on the same channel at the same time on the same day.

Note: You can record only the program to which the receiver is tuned. If you open any menu (including the **Program Guide**) while recording a program on videotape, the menu also will be recorded. If a program time changes by more than 24 hours, the timer will not operate.

BEFORE AN EVENT TIMER OPERATES

Five minutes before an event timer operates, the receiver displays a small blinking “clock” symbol on the TV screen. This symbol disappears when the program begins. While the symbol is displayed, you may do either one of the following.

- Press the remote control **CANCEL** button to clear the symbol from the TV screen. This does *not* affect the timer; it *will* operate.
- Press the remote control **INFO** button to see more information on the event timer. If you do this, you will have the following choices:
 - Select the **OK** or **Cancel** option to continue with the event timer.

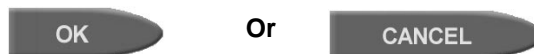

Select the **Stop Timer** or **No** option to stop the event timer.

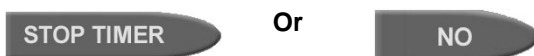

Note: This stops *only* this instance of a *Mon.-Fri.*, *Daily* or *Weekly* timer. The timer *will* operate the next time it is scheduled. To stop all operations of such a timer, you *must* delete the timer. For a *Reminder Event Timer*, instead of having the option to stop the timer, you have the option to tune to the program.

SETTING UP AN AUTOMATIC EVENT TIMER



1. Select a future program using the **Browse Banner, Themes and Search** or the **Program Guide**.
2. Select a **Timer Type** option.
3. Select a **Timer Frequency** option. Notice that a check mark displays in the box.
4. Select the **Create** option to save the event timer.



5. The receiver displays a timer symbol in the **Program Guide**, and also when you press the **INFO** button to get information about the program.

SETTING UP A MANUAL EVENT TIMER

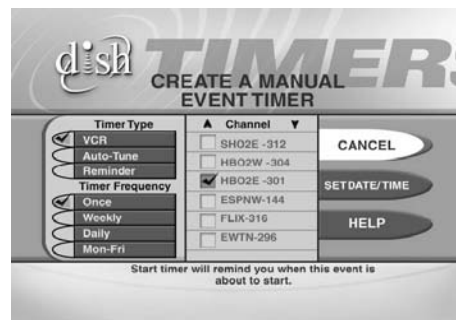

1. Press the **MENU** button.
2. Select the **Timers** option.
3. Select the **Create** option. The receiver displays the **Create a Manual Event Timer** menu.
4. Select a **Timer Type** option.
5. Select a **Timer Frequency** option.

MENU



7

Tip: You may start any timer one minute early. But if you set back-to-back event timers and the second one starts early, the first one will end early. An event timer cannot start early for a pay per view program. If you try to set a timer for overlapping events, you will get an error message.

Tip: Use the **Program Guide** or your printed television guide to see when the program(s) starts and stops — before you go to the **Set Date/Time for Manual Timer menu**.

6. Select a channel:

- Highlight a channel using the UP or DOWN ARROW button. Then, press the SELECT button.
- Enter a channel number using the number buttons.



7. Select the **Set Date/Time** option. The receiver displays the **Set Date/Time for Manual Timer** menu.



8. Use the NUMBER PAD buttons to enter the **Start Time** (this includes selecting **AM** or **PM**) and the **End Time** (this includes selecting **AM** or **PM**).



9. Use the NUMBER PAD buttons to enter the **Date**.

10. Select the **Create Timer** option.

11. To create another event timer select the **Create** option again.



Note: You cannot set a manual event timer for a pay per view event.

OVERLAPPING EVENT TIMERS

If you try to create event timers for overlapping programs, the receiver displays a menu with the dates and times of both programs. The receiver also displays this menu if a program time has changed, causing one timer to overlap another. You *must* delete *or* edit one of the timers.



Tip: The receiver deletes Once event timers when they operate. You must delete all other types of event timers yourself.

MAXIMUM NUMBER OF EVENT TIMERS

You can create a limited number of event timers. If you try to create more, the receiver displays a menu giving you the option to delete an existing timer. If you do not delete an existing timer, you will *not* be able to create any new ones.

EDITING AN EVENT TIMER

- You can edit almost any feature of an event timer.
- You can edit both *automatic* and *manual* event timers.
- Editing an *automatic* event timer *converts* the timer to a *manual* event timer that operates at the times you set, *not* the actual program times.

1. Press the **Menu** button.



2. Select the **Timers** option.



3. The receiver displays the **Event Timer Management** menu.

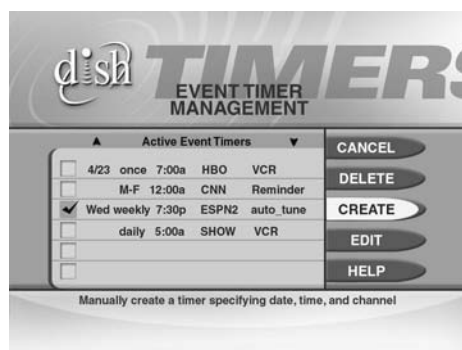

4. Select the event timer that you want to edit. A check mark appears in the box next to the event timer. Select the **Edit** option.



5. You may change the **Timer Type**, **Timer Frequency**, or **Channel**. To do this, select each option that you want.

6. If you want to change the **Start Time**, the **End Time**, or the **Date**, select the **Set Date/Time** option to display the **Set Date/Time for Manual Timer** menu. Otherwise, skip to step 9, below.



7. Use the **NUMBER PAD** buttons to enter the **Start Time** (this includes selecting **AM** or **PM**) and the **End Time** (this includes selecting **AM** or **PM**).

8. Use the **NUMBER PAD** buttons to enter the **Date**.

9. Select the **Create Timer** option.



10. To edit another event timer,

Either: Highlight that timer and select the **Edit** option again.

Or: If you do not want to edit another event timer, press the **CANCEL** button.

DELETING AN EVENT TIMER

1. Press the MENU button.

MENU



2. Select the **Timers** option.



3. The receiver displays the **Event Timer Management** menu.



4. Select an event timer that you want to delete. A check mark appears in the box next to the event timer.
5. Move to **Delete** and press SELECT on the remote.



Do this again for any other timer(s) that you want to delete.

REVIEWING EVENT TIMERS

You can review event timers by using the **Event Timer Management** menu.

1. Press the MENU button.

MENU



2. Select the **Timers** option.









3. The receiver displays the **Event Timer Management** menu.

Setting Up the Receiver to Control the VCR

To use *VCR Event Timers*, you *must* connect the receiver's back panel **CH 3-4** output to the tuner inputs on the VCR. To use *VCR Event Timers*, you *must* set up the receiver to control the VCR.

The receiver uses an IR signal to control the VCR. This signal is much stronger than the signal the remote uses, so it can bounce off walls or other objects on its way to the VCR. This works in most home setups. However, shelves or smoked glass doors between the receiver and the VCR may block the signal. Also, if the signal must cross a very large room, or bounce off curtains, it may not be strong enough to control the VCR. Make sure that nothing blocks the signal, and that the signal can bounce off relatively nearby, light-colored, smooth surfaces.

1. Press the **MENU** button. 
2. Select the **System Setup** option. 
3. Select the **Installation** option. 
4. Select the **VCR Setup** option. 
5. Find the brand name of the VCR in the table on page 81.
6. Set the code for the VCR using one of the following:
 - Enter the first 3-digit code number from the table using the **NUMBER PAD** buttons.
 - Highlight each digit of the first VCR code, and then press the **UP** or **DOWN ARROW** button until you reach the correct number and then press **SELECT**. 
7. Make sure the VCR is turned ON and the switch is set to 3 or 4 (whichever you use). Insert a rewind tape on which you want to record. The receiver starts the VCR recording, but does not turn ON the VCR, so you must do this yourself.
8. To test the new code, highlight the **Test** option. The receiver displays a message warning you to make sure the VCR is turned ON.
9. Press the **SELECT** button to start the test. Your VCR records for a few seconds, stops, and then rewinds. The receiver displays a message saying that your VCR test is complete. Follow the instructions on the message. 

10. If your VCR did not complete the test, enter another code from the table, and then repeat steps 5 through 8.
11. Once you have found the correct VCR code select the **Save** option to save the VCR code you entered and return to the **Installation and Setup** menu.

Note: If the receiver *can't* control the VCR, use an *Auto-Tune Event Timer* to tune the receiver to the channel you want to record. Use the timers built into the VCR to start and stop the VCR at the right times.

LOCKS, BLACKED-OUT PROGRAMS, AND EVENT TIMERS

You *must* enter the receiver password *before* you can create an automatic event timer for a locked program, and you must order a pay per view program *before* you can create a timer for it. You can create a manual event timer for a locked program *without* entering the password. However, if you do this, or if the program is blacked out in your area, when the event timer operates the receiver may display *only* an error or password entry menu. If you have set a *VCR Event Timer*, the VCR will record *only* that menu.

POWER OFF AND EVENT TIMERS

If the receiver is OFF at the time an *Auto-Tune* or *VCR Event Timer* is scheduled to operate, the receiver will turn ON. Once the event has ended, the receiver will turn OFF, unless you pressed any remote control or receiver front panel buttons during the time that the timer was active.

If the receiver is OFF at the time a *Reminder Event Timer* is scheduled to operate, the timer will turn the receiver ON and tune it to the channel you last watched. The receiver will then display the reminder menu. You will have a few seconds to respond. If you do not respond to the reminder menu, the receiver will turn OFF.

USING LOCKS



First you set the locks; then you lock the receiver. You must lock the receiver in order to put any locks into effect. If you unlock the receiver, leave the locks unchanged, and then lock the receiver again, the same locks will be in effect as before.

HOW TO SET LOCKS: A TWO STEP PROCESS

1. Create the locks that you want.
2. Lock the receiver.

Once the receiver is locked, anyone who wants to access locked items *must* enter the password.

WHEN YOU HAVE LOCKED THE RECEIVER

If you try to access a locked item or open the **Parental and System Locks** menu, the receiver displays a message prompting you to enter the password.

The receiver allows you three tries to enter the correct password. If you fail to enter the correct password, the receiver does not allow more tries for several minutes.

If you enter the correct password, you can access the locked item or open the **Parental and System Locks** menu.

If you exit a locked item or close the **Parental and System Locks** menu, you *must* enter the password again to access the item or open the menu again.





If you forget your password, you will need to speak with a Customer Service Representative and may need to provide some information related to your account including a Personal Identification Number (PIN), if used. See page 44 for information on PINs.

CREATING A PASSWORD

You must lock the receiver for any receiver **Parental Locks** you set to take effect. To lock the receiver, *you must first create a password*. If you forget your password, you will need to call the Customer Service Center at 1-800-333-DISH (3474).

To create a password:

1. Press the MENU button to display the **Main** menu. 
2. Select the **Locks** option to display the **Parental and System Locks** menu. 

Note: If the receiver displays a message prompting you to enter a password, the receiver has already been locked.
3. Select the **Lock System** option. The receiver displays a message prompting you to enter a password. 

Note: If this option appears as **Unlock System** instead, the receiver is already locked.
4. Enter and verify a password, using the number pad buttons. The receiver displays stars (*) as you enter the digits of the password.
5. **Memorize your password.** From now on, you must enter this password to lock or unlock the receiver.
6. Highlight and select the **OK** option. Re-enter the password. All the locks you have set are now in effect.

CREATING OR CHANGING RATING (CONTENT) CODE LOCKS



Please be aware of the following: The locks use the codes that the original program providers assigned to the programs. The actual content of the programs may differ from their assigned ratings. No rating system can guarantee that all objectionable material is screened out. Like all other locks, these locks are only in effect when the receiver is locked. You can lock any program, including pay per view programs. The locks built into some televisions do not apply to satellite programs. Television program ratings differ from movie ratings.

Do the following to set program locks based on rating codes. Then, when the receiver is locked, *only* someone who knows the password can watch these programs.

1. Press the MENU button.

MENU



2. Select the **Locks** option.

If the receiver is locked, enter the password using the number pad buttons. The receiver displays stars (*) as you enter the digits of the password. As soon as you enter the fourth digit of the password, the receiver highlights the **OK** option. Press the **SELECT** button.

5

3. Select the **Ratings Locks** option.

Highlight the rating that corresponds to the lowest acceptable audience age. Press the **SELECT** button to lock the highlighted rating.





1

Note: All ratings that are more restrictive than the selected rating are also selected. *For example*, if you lock PG-13 rated programs, then all programs with the R, NC-17, and NR/AO ratings are also locked.



4. Select the expanded rating code(s), if you want to also lock these ratings.
5. To unlock a rating code, highlight the code and press **SELECT**.
6. Select the **Save** option to save the changes.
7. If the receiver is not locked, you must lock it to put the locks you just created into effect.

CREATING OR CHANGING CHANNEL LOCKS

Note: You can lock *any* channel, including pay per view channels.

1. Press the **MENU** button. 
2. Select the **Locks** option. 
3. If the receiver is locked, enter the password using the number pad buttons. The receiver displays stars (*) as you enter the digits of the password. As soon as you enter the fourth digit of the password, the receiver highlights the **OK** option. Press the **SELECT** button. Select the **Channel Locks** option. 
4. Highlight the channel that you want to lock. If necessary, press the **UP** or **DOWN ARROW** button to see the desired channel. You can also enter each channel number using the number pad buttons. 
5. Press the **SELECT** button to lock or unlock the highlighted channel. If the checkbox next to the channel has a checkmark, the channel is locked.
6. Select the **Save** option to save the changes.
7. If the receiver is not already locked, you must lock it to put the locks you just created into effect.

LOCKING THE RECEIVER

1. Press the **MENU** button. 
 2. Select the **Locks** option. 
 3. Select the **Lock System** option. 
The receiver displays a message prompting you to enter a password.
- Note:** If this option appears as **Unlock System** instead, the receiver is already locked.
4. Enter and check a password, using the number pad buttons. The receiver displays stars (*) as you enter the digits of the password. *Memorize your password.* From now on, you *must* enter this password to lock or unlock the receiver.
 5. Select the **OK** option. Enter the password again.

UNLOCKING THE RECEIVER

If you unlock the receiver, leave the locks unchanged and then lock the receiver again, the same locks will be in effect as before.

1. Press the MENU button to display the **Main Menu**.



2. Select the **Locks** option.



3. With the receiver locked, you must enter the password using the NUMBER PAD buttons. The receiver displays stars (*) as you enter the digits of the password. As soon as you enter the fourth digit of the password, the receiver highlights the **OK** option.

4. Press the SELECT button.

5. Select the **Unlock System** option.

Note: If this option appears as **Lock System** instead, the receiver is already unlocked.



LOCKING THE RECEIVER FRONT PANEL CONTROL BUTTONS

This keeps anyone from changing the channel, but it does *not* lock the remote control buttons. Remember that you must lock the receiver for this lock to take effect.

To lock the receiver front panel buttons, do the following:

1. Press the MENU button.



2. Select the **Locks** option.



If the receiver is locked, enter the password using the number pad buttons. The receiver displays stars (*) as you enter the digits of the password. As soon as you enter the fourth digit of the password, the receiver highlights the **OK** option. Press the **SELECT** button.

3. Select the **Front Panel Lock** option.



4. Select the **Yes** option.

5. If the receiver is not locked, you *must* lock it to put the lock you just created into effect.

UNLOCKING THE RECEIVER FRONT PANEL CONTROL BUTTONS

To unlock the receiver front panel buttons, you must use the remote control.

1. Press the **MENU** button.



2. Select the **Locks** option.



If the receiver is locked, enter the password using the **NUMBER PAD** buttons. The receiver displays stars (*) as you enter the digits of the password. As soon as you enter the fourth digit of the password, the receiver highlights the **OK** option. Press the **SELECT** button.

3. Select the **Front Panel Lock** option.



4. Select the **Yes** option.

LOCKING PAY PER VIEW PROGRAMS

This locks all pay per view channels. Remember that you must lock the receiver for this lock to take effect.

You also can lock one or more pay per view channels by using channel locks or rating locks.

1. Press the **MENU** button.



2. Select the **Locks** option.



If the receiver is locked, enter the password using the number pad buttons. The receiver displays stars (*) as you enter the digits of the password. As soon as you enter the fourth digit of the password, the receiver highlights the **OK** option. Press the **SELECT** button.

3. Select the **Lock PPV** option.
4. If the receiver is not locked, you *must* lock it to put the lock you just created into effect.



To unlock pay per view programs:

5. Press the **MENU** button.



Tip: If this option appears as **Unlock PPV** instead, pay per view programs are already locked.

Tip: If the receiver displays a message prompting you to enter a password, it already has been locked.

Tip: If this option appears Unhide Adult instead, the adult channels are already hidden.

6. Select the **Locks** option.

If the receiver is locked, enter the password using the **NUMBER PAD** buttons. The receiver displays stars (*) as you enter the digits of the password. As soon as you enter the fourth digit of the password, the receiver highlights the **OK** option. Press the **SELECT** button.

5

7. Select the **Unlock PPV** option.

Note: When you select this option, you unlock all pay per view channels.

6

HIDING ADULT CHANNELS

This keeps the **Program Guide**, **Themes** lists, and the **Browse Banner** from displaying adult channels. It keeps anyone from choosing such channels by using the **UP** or **DOWN ARROW** buttons or the remote control **NUMBER PAD** buttons. Remember that you must lock the receiver for this lock to take effect.

To hide adult channels:

1. Press the **MENU** button.

MENU



2. Select the **Locks** option.

If the receiver is locked, enter the password using the number pad buttons. The receiver displays stars (*) as you enter the digits of the password. As soon as you enter the fourth digit of the password, the receiver highlights the **OK** option. Press the **SELECT** button.

5

3. Select the **Hide Adult** option.

7

4. If the receiver is not locked, you *must* lock it to put the lock you just created into effect.

To show adult channels:

1. Press the **MENU** button.

MENU



2. Select the **Locks** option.

If the receiver is locked, enter the password using the number pad buttons. The receiver displays stars (*) as you enter the digits of the password. As soon as you enter the fourth digit of the password, the receiver highlights the **OK** option. Press the **SELECT** button.

5



3. Select the **Show Adult** option.

7

OPENING A LOCKED ITEM, OR OPENING THE LOCKS MENU

1. Select an item that is locked.
2. The receiver displays an **Attention** message telling you that the item or menu is locked.
3. Enter the password using the number pad buttons. The receiver displays stars (*) as you enter the digits. As soon as you enter the fourth digit of the password, the receiver highlights the **OK** option.
4. Press the **SELECT** button.

CHANGING THE RECEIVER PASSWORD

1. Press the **MENU** button. 
 2. Select the **Locks** option.
If the receiver is locked, enter the password using the number pad buttons. The receiver displays stars (*) as you enter the digits of the password. As soon as you enter the fourth digit of the password, the receiver highlights the **OK** option. 
 3. Press the **SELECT** button.
 4. Select the **Change Password** option. 
 5. Enter the *current* password using the number pad buttons.
As soon as you enter the fourth digit of the password, the receiver highlights the **OK** option.
 6. Press the **SELECT** button.
 7. Enter the *new* password using the number pad buttons.
As soon as you enter the fourth digit of the password, the receiver highlights the **OK** option.
 8. Select the **OK** option to change the password.
 9. Enter the *new* password again, using the **NUMBER PAD** buttons. The receiver displays stars (*) as you enter the digits of the password. As soon as you enter the fourth digit of the password, the receiver highlights the **OK** option. Press the **SELECT** button.
- Memorize the new password.** From now on, you *must* enter this password to lock or unlock the receiver.

PERSONAL IDENTIFICATION NUMBER

You can set up a Personal Identification Number (PIN) for call-in requests *only*. Anyone calling the Customer Service Center *must* provide this PIN to make any changes to your account. You may call the Customer Service Center at any time to set up a PIN.

If you forget your PIN, you will need to call the Customer Service Center. The representative may ask for more information to make sure that you are authorized to make changes to your account.

USING CALLER ID

Caller ID displays on your TV the names of people as they call you *if you subscribe* to Caller ID from your local phone company. To use this feature, make sure you have a phone line connected to the receiver and that the **Caller ID** feature is enabled. After you turn on **Caller ID**, it stays on until you decide to turn it off.

Note: For best performance, make sure your system is properly grounded.

CALLER ID SCREENS

When you receive a call, you will see a **Caller ID** popup screen.



You can select **OK** to eliminate the message. If you do nothing, it will disappear after 20 seconds.

If you are in a menu when a call comes in, you will see a different **Caller ID** popup screen.

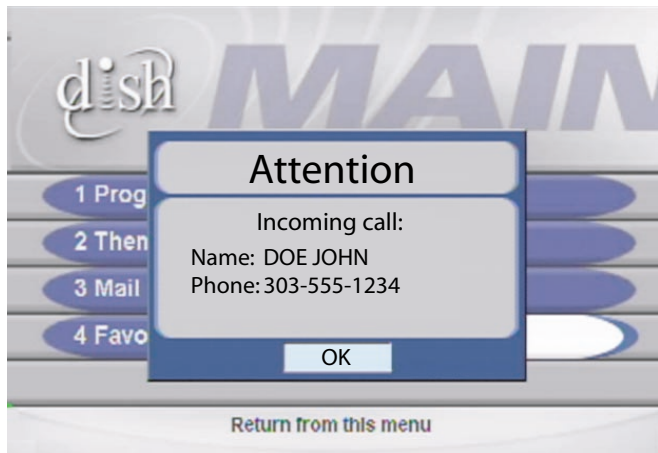

To TURN THE CALLER ID ON AND OFF

1. Press MENU.
2. Select the **System Setup** option.
3. Select the **Installation** option.
4. Select the **Caller ID** option. The following screen will display.



5. Highlight **Enable Caller ID** or **Disable Caller ID** and press SELECT.
6. Select **Save**.

RESTARTING THE RECEIVER



If your receiver stops responding to remote control or front panel commands, press and hold the front panel **POWER** button for 4 seconds. When you release the **POWER** button, the receiver will restart.

RESETTING THE RECEIVER TO FACTORY SETTINGS

Use these instructions if you want to reset the receiver to be the same as when it was shipped.

Note: Resetting the receiver discards all Favorite Lists *except* the **All Chan** and **All Sub** lists.

Note: If you have set *any* locks on the receiver, and the receiver is locked, these locks will be kept. If the receiver is unlocked, any such locks will be lost. You *cannot* reset the receiver to default settings to discard a password you have forgotten. Only the Customer Service Center can reset the receiver to bypass a receiver lock.

1. Press the **MENU** button. 
2. Select the **System Setup** option. 
3. Select the **Installation** option. 
4. Select the **Factory Defaults** option. The receiver displays a **Warning** message, prompting you to confirm that you want to reset the receiver.
5. Select the **Yes** option to confirm the reset. The receiver resets, and then displays the **Installation and Setup** menu.

CHANGING PROGRAM LANGUAGES

You may be able to change the language of some programs. An alternate language may not be available for all programs. Some programs, such as movies, show at the start whether an alternate language is available. An alternate language applies *only* to the audio part of a program and does *not* change the language used in the menus displayed by the receiver.

1. Press the **MENU** button. 

Tip: You can choose an alternate language (if available) but this applies only to the audio part of a program and does not change the language used in the menus displayed by the receiver.

2. Select the **System Setup** option.



3. Select the **Alternate Audio** option.



4. Select the language you want in the **Languages** list.

Note: **Alternate** provides visually-impaired customers with a visual description of the program.

5. Select **Save** to save your language choice. The receiver displays the **System Setup** menu.
6. Press **VIEW TV** to exit the **System Setup** menu.

TESTING THE PHONE CONNECTION

STARTING A TEST

1. Press the **MENU** button.



2. Select the **System Setup** option.



3. Select the **Diagnostics** option.



TELEPHONE CONNECTION TEST

This test checks that the receiver telephone connection is correct. Select the **Connection** option to begin the test. The receiver displays a message asking you to wait until the test is done.

- If the telephone connection is correct, the receiver displays a **Phone Connection OK** message.
- Select the **Dial Out** option so the receiver can make a toll-free call to the Customer Service Center. Press the **SELECT** button to start the call. When the call is done, select the **Cancel** option to exit the test menu.
- If the telephone line is not connected properly, the receiver displays a failure message. Check the telephone connection and then repeat the test.

Note: If you have the receiver connected to a DSL (Digital Subscriber Line) phone line, it may cause this test to fail. If so, you will need to install a DSL filter between the receiver and the phone jack on the wall.

Tip: Before you do the telephone test, make sure that an active telephone line is connected to the Telephone Jack on the receiver back panel.

Tip: You can get a DSL filter from your Internet Service Provider or a local electronics parts store.

SETTING UP THE RECEIVER FOR CHANNEL 3 OR 4

Your receiver comes preset to tune to channel 3 on the TV. If you need to change the channel your TV uses, do the following:

1. Press the **MENU** button.
2. Select **System Setup**.
3. Select **3/4 Modulator**. The **Select Output Channel** screen displays.

MENU



6

9



4. Select either **Channel 3** or **Channel 4**.
5. Select **Save**.
6. Tune your TV to the same channel (3 or 4) that you selected on the **Select Output Channel** screen.

Chapter 4

Installation Instructions

How to Use these Instructions

These instructions guide you through the installation of a satellite system which includes your DISH Pro receiver (included with this manual), and a DISH Pro antenna system that can be identified by the DISH Pro logo shown below.



Connecting Your TV and VCR

Use the following diagram and instructions to connect the satellite receiver to a dish antenna, TV, and VCR (optional).

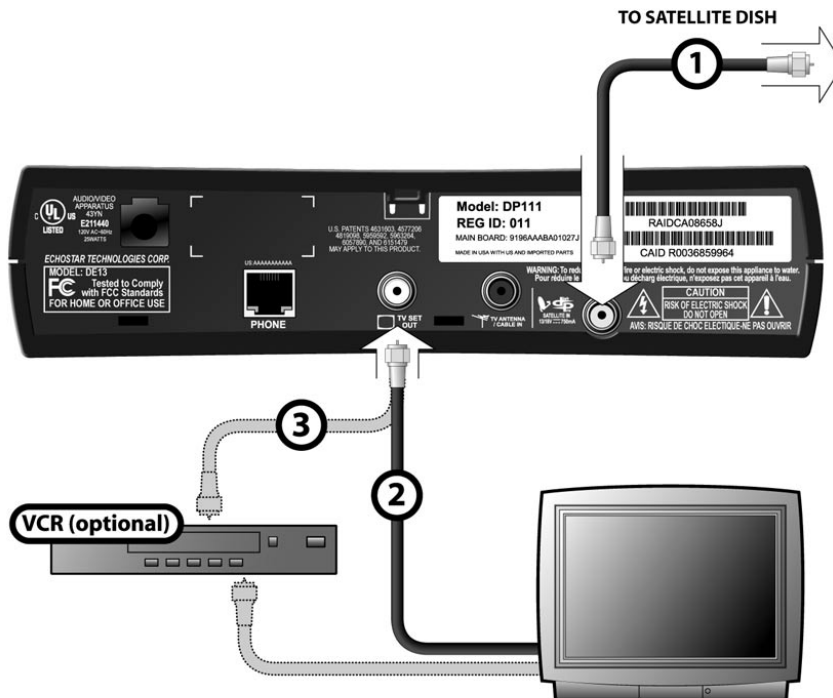

Tip: Using cable labels makes it easy to tell which cables connect to the receiver ports.

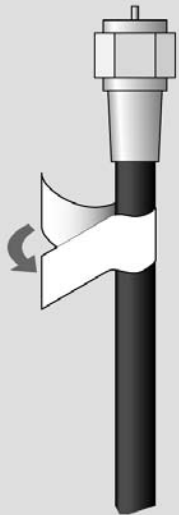

- 1 **Sat In** - Connect a coaxial cable between the DishPro LNBF and **SAT IN** on the back of the receiver. Peel off the blue sticker and affix it to the cable close to where it connects to the **SAT IN** connection on the back of the receiver.
- 2 **TV Set Out to a TV** - Connect a coaxial cable between the **TV SET OUT** on the receiver and the TV's input. Peel off the white sticker and affix it to the cable close to where it connects to the **TV SET OUT** connection on the back of the receiver.
- 3 **TV Set Out to a VCR** (Optional) - Connect a coaxial cable between the **TV SET OUT** on the receiver and the VCR's input. Connect another cable between the VCR's output and the TV's input.
- 4 **Set the receiver to tune to channel 3 or 4** - Make sure the TV and VCR (if installed) are on the channel you set in the 3/4 Modulator screen. The receiver comes preset to channel 3. See *Setting Up the Receiver For Channel 3 or 4* on page 48.

Installing a DISH 500 Antenna

Note: If you have a Dish antenna system already installed, and the dish has been pointed for the strongest possible signal strength, you can skip this chapter and go directly to *Appendix A* to install the satellite receiver in an existing system.

The first step in installing your dish antenna is to assemble the satellite dish, mount it, and point it in the general direction of a satellite. To do this, follow these instructions:

Finding the Satellites

You need to find the satellites in the sky. To do this, you need to know the azimuth angle (the south, southeast, or southwest direction to the satellites) and the elevation angle (the angle up to the satellites) from your location, and the skew angle.

1. Make sure that the remote control batteries are fresh, and are installed properly.
2. Turn ON the television and receiver.

3. Display the **Point Dish and Signal Strength** menu by pressing **MENU** and then **6-1-1** (unless the receiver already displays this menu).

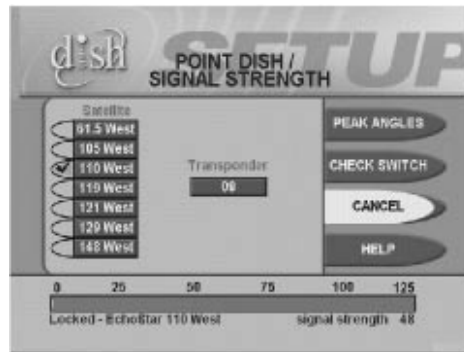

4. Select **Peak Angles**.
5. Enter your ZIP code in the **ZIP Code** field.
6. Select the **Dish 500** option.

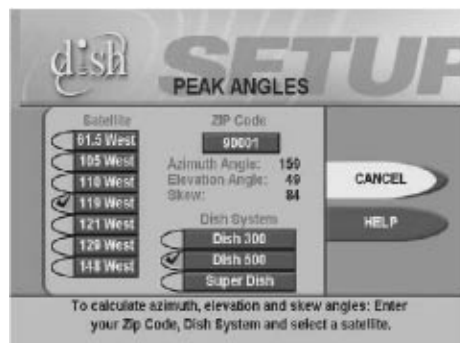

7. The menu displays the azimuth, elevation, and skew angles. Write down these numbers in the blanks provided in the margin.
8. Select **Cancel** to exit out of this menu and return to the **Point Dish/Signal** menu.
9. Go to *Mounting the Dish* on page 52.

Azimuth: _____

Elevation: _____

Skew: _____

Mounting the Dish

1. Using these azimuth and elevation angles, find a location for the satellite dish which can be pointed towards the satellites located at these angles. With a compass, find the required azimuth angle. Then, use the elevation angle to find out how high the satellites are in the sky from your location. Make sure nothing blocks the line of sight between the dish and the satellites.
2. Mount the mast to a solid surface so that the dish antenna cannot move or be bumped out of adjustment. Keep in mind that physical and environmental conditions can block your satellite dish's ability to receive a clear satellite signal. The conditions to be aware of are: Eaves and overhangs on your building or house, wind, plant growth, and deterioration of the mounting surface. Never mount to a tree.

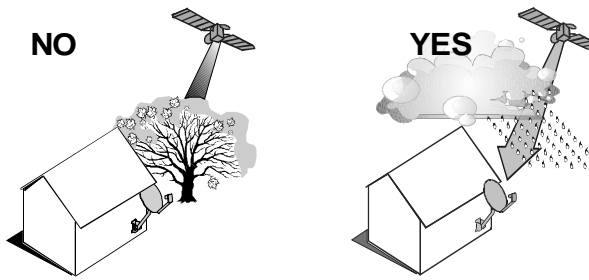

3. Align the top part of the mast so that it is absolutely vertical, as shown below. If the top part of the mast is off vertical by only a few degrees, it will be difficult or maybe even impossible for you to find the satellites. Take at least two readings with a bubble level, on the upper mast, that are 90 degrees apart from one another.

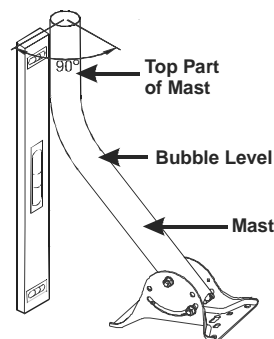

4. Assemble the satellite dish as shown below, except do not attach the Y-bracket or LNBF at this time.

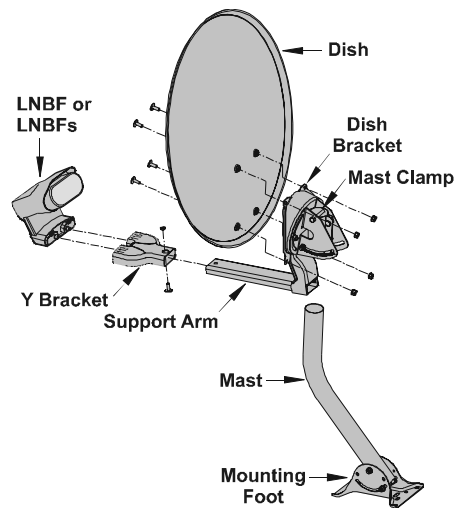

5. Loosen both skew bolts and set the skew by rotating the dish mounting bracket to align the red mark with the required angle on the skew scale which you wrote down on 51. Tighten the skew bolts securely to keep the dish from rotating. **Once the skew is set, do not try to fine-tune this angle when aiming the dish.**

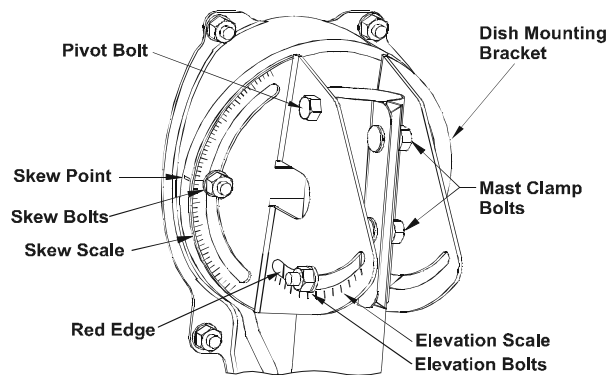

6. Set the elevation by tilting the dish mounting bracket to align the red edge with the required angle from page 51 on the elevation scale. Tighten the elevation bolts, but *do not* tighten the pivot bolt at this time.
7. Slide the dish assembly down onto the mast. Make sure the pivot bolt rests on the top of the mast. Turn the dish assembly so that it points in the general direction of the satellites, using the azimuth angle from 51.

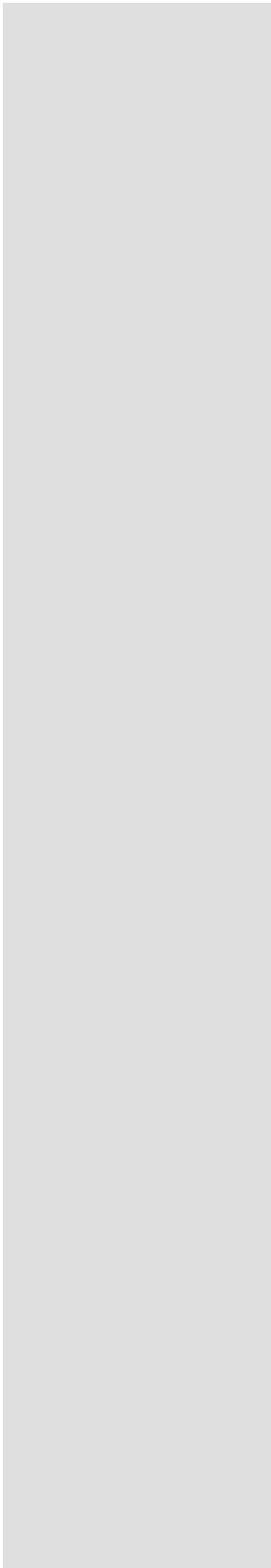

8. Thread the RG-6 coaxial cable through the mast support arm and the Y-bracket. This cable should be long enough to run from your receiver to your LNBF.

Note: See *Running Coaxial Cables* on page 67 for cable installation guidance.

Note: You can have as much as 200 feet of cable between the DishPro LNBF and the DishPro receiver. However, you must use only RG-6 coaxial cables rated for 950 to 2150 MHz. Some cables may say "Swept tested for 2150 MHz." If you have any doubt about this, ask your DISH retailer, or look on the container the cable came in. Do not use cable company TV cables or cables from other satellite TV systems not rated for 950-2150 MHz. These other cables may cause signal loss. Do not use existing cables such as RG-59. Also, be sure that any outdoor connections are made using waterproof F-connectors.

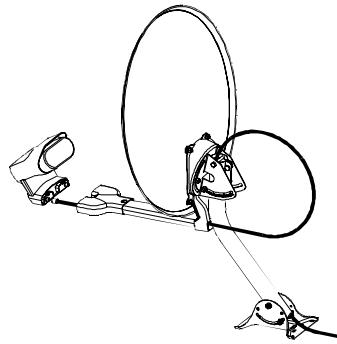

9. Attach the Y-bracket, using the Y-bracket screw.
10. Connect the RG-6 cable from the DISHPro **SAT IN** connection on the back of the receiver *directly to port 1* of the DISHPro Twin LNBF, as shown below. Be sure there are no multi-dish switches between the LNBF and the receiver.



Tighten all of the coaxial cable connection *only* by hand. If you use a wrench, you may over-tighten the connections and damage your equipment. Such damage is *not* covered by the Limited Warranty.

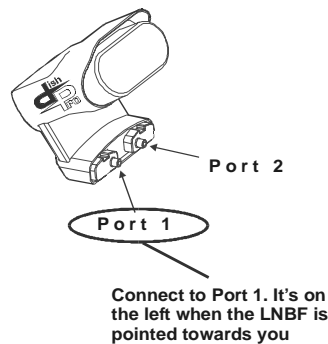

11. Attach the LNBF to the Y-bracket using the two LNBF screws.

12. You should see the **Point Dish/Signal** menu. If not, open the **Main Menu**, select **System Setup**, then **Installation**, then **Point Dish/Signal** (press MENU and then press 6-1-1 on the remote).

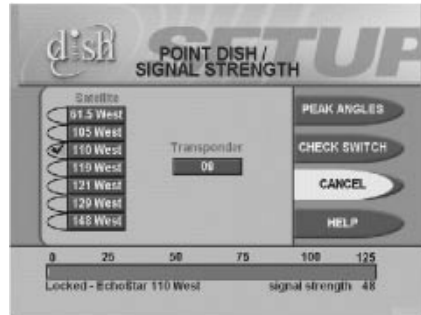

13. Select **Check Switch**. The **Check Switch** screen will open.
14. Select **Test**. The receiver shows you a message that it is checking the switches.
15. When the check switch procedure finishes, you will see an installation summary screen similar to the one below. In the **Satellite** line, you will see “Conn.” In the **Device** line, you will see “Twin” twice. This indicates that your receiver has confirmed the connection with your DishPro Twin LNB is working. The Transponder line may show two “Xs.” This is OK and does not indicate a problem with the receiver.



16. Select **Cancel** or **OK** to return to the **Point Dish/Signal** screen. Make sure the check mark is next to **119 West**. If not, move the highlight to **119 West** and press **SELECT**. Notice the signal strength bar. This is used to help you aim the dish by showing the strength of the signal you are receiving. Look at the signal strength bar while you aim the dish. Don't stand in front of the dish while you aim it, because your body will block the satellite signal. After you adjust the aim, let go of the dish so that you can get a good signal reading after the dish settles back in place by itself. **Do not change the skew setting.**

Tip: Have one person aim the dish while another watches the signal strength or listens to the signal tone.

17. Turn the dish back and forth *very slowly*, until the signal strength bar turns *green*. This shows you've found the signal.

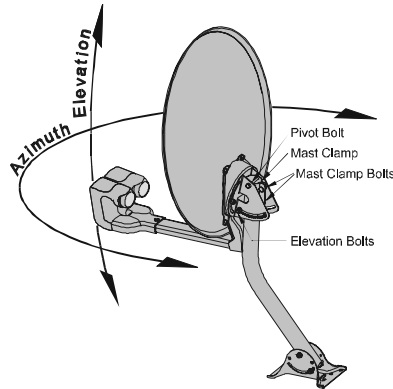

Note: If you cannot find the signal, turn the dish back to the first azimuth angle. Then, loosen both elevation bolts *just enough* so you can tilt the dish. Tilt the dish elevation up by two degrees, and then tighten both bolts. Now, turn the dish back and forth again. *If you still can't find the signal*, tilt the dish up again *very slightly* and turn the dish back and forth until you find the signal.

18. Once the signal strength bar is *green*, turn the dish back and forth *just a little*, to where the signal strength bar shows the strongest signal. When you find the strongest signal, tighten both mast clamp bolts. Then loosen both elevation bolts, *just enough* so you can tilt the dish. Tilt the dish up and down *just a little*, to where the signal strength bar shows the strongest signal. **Do not adjust the skew.** When you find the strongest signal, tighten all bolts in the dish assembly so the dish cannot be moved.
19. You are now ready to verify reception from both satellites. Select the **Check Switch** option. When the **Check Switch** menu opens, select **Check** or **Test**. The receiver shows you a message that it is checking the switches. When the procedure is finished, you will see an **Installation Summary** screen. This screen may look different than the one shown below. However, you *must* see that you have *signals from both* the **110 West** and **119 West** Satellites, you see "All" twice in the **Transponder** line, and the message "Satellite reception verified. Press CANCEL or OK to exit this menu."



20. If you do not see "110" under **Dish Input 2**:

- Make sure the skew angle you wrote down on page 51 is exactly the same as the skew angle you set in step 5 on page 53. If it is not, reset the skew angle as described on page 53. After you reset the skew angle, go back page 55 and start over from step 16.
 - If “119” is shown under **Dish Input 2**, move the dish approximately 9° to the east and restart the procedure at step 12.
21. Look at the **Point Dish/Signal** menu. If you have good signal strength with the check mark in **119 West**, move the check mark to **110 West**. If you have good signal strength on **110 West**, go to step 22.
- If you do not have good signal strength with the check mark in **110 West**, go back to Step 17, and fine-tune the dish but with the check mark in **110 West** instead of **119 West**. While the 110 West and 119 West signals will not be equal, you should be able to fine-tune the dish until you have the strongest possible signal from both satellites.
22. Select Cancel to exit the **Point Dish/Signal** menu. An Attention screen will open asking the mounting and positioning of your dish is complete with a “Locked” indication in the Point Dish/Signals screen. If the answer is yes, select **Yes**.
- If the answer is **No**, you will need to repoint your dish following the preceding steps until the mounting and positioning is complete and you do have the “Locked” indication.*
23. After you select **Yes**, the receiver will begin taking a software upgrade. You will see a **Warning** that “Vital program information will now be downloaded into your receiver.” You will also see a status bar showing the progress of this upgrade.
24. Once the software upgrade is complete, you will see a message that your receiver’s memory is being upgraded.
- Do not disturb the receiver while the receiver’s memory is being upgraded.
- Note:** If you are installing other DishPro receivers, be sure to run **Check Switch** on all of them, and allow them to take the necessary software upgrade.
25. When the memory has been upgraded, your installation is complete.

Installing a Multiple Dish DishPro System

Note: You cannot use DishPro LNBFs and switches (those marked with the DishPro logo) with Legacy (non-DishPro) switches and LNBFs (those without the DishPro logo). You must install your DISH antenna system with either all DishPro LNBFs and switches or all Legacy LNBFs and switches. If you mix the two, the system will not work.

Note: You can have as much as 200 feet of cable between the DishPro LNBF and the DishPro receiver. However, you must use only RG-6 coaxial cables rated for 950 to 2150 MHz. Some cables may say "Swept tested for 2150 MHz." If you have any doubt about this, ask your DISH retailer, or look on the container the cable came in. Do not use cable company TV cables or cables from other satellite TV systems not rated for 950-2150 MHz. These other cables may cause signal loss. Do not use existing cables such as RG-59. Also, be sure that any outdoor connections are made using waterproof F-connectors.

Once you have installed the DISH 500 with its DishPro Twin LNBF using the preceding instructions, you can install a DISH 300 with a DishPro LNBF as follows:

1. Turn on the television and the receiver if they are not already on. You should see the **Point Dish/Signal** screen. If not, open the **Main Menu** and press 6-1-1 on the remote.

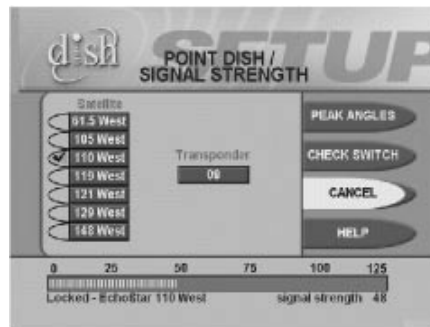

2. Make sure the check mark is next to the satellite your dish will be pointed toward.
3. Select **Peak Angles** and then select the **Dish 300** option.
4. Use the number buttons on the remote to enter your ZIP code to get the necessary azimuth and elevation. Write these numbers down in the spaces provided in the margin.
5. Mount the dish antenna following the mounting instructions that came with it.
6. Connect an RG-6 cable from the DishPro **SAT IN** connection on the receiver directly to the DishPro LNBF on the Dish 300. Make sure there are no multi-dish switches between the LNBF and the DishPro receiver.
7. Select **Cancel** to go back to the **Point Dish/Signal** screen.

Azimuth: _____

Elevation: _____

8. Select **Check Switch**. When the **Check Switch** screen opens, select **Test**.
9. When **Check Switch** is complete, you will see an **Installation Summary** screen similar to the one shown next. It will show a connection (“Conn” next to satellite) and **Single** device under **1** (Dish Input). It may also show an **X** on the Transponder line. This is OK and does not mean there is a problem with the system.

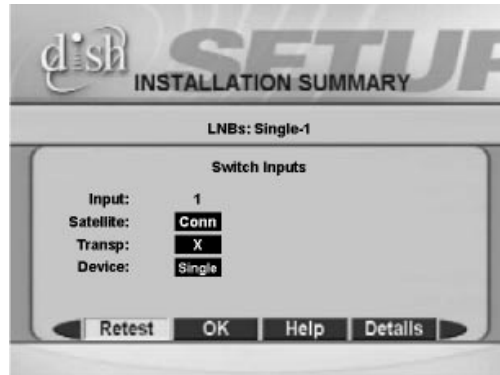

10. Press **CANCEL** to exit back to the **Point Dish/Signal** menu.
11. Point the dish for the strongest possible signal, following the instructions that came with it and the DishPro wiring diagrams that start on page 60.
12. Connect any switches in your system, using the instructions which came with the switch(es).
13. Select **Check Switch** from the **Point Dish/Signal** menu. When the **Check Switch** menu opens, **Test**. When the procedure completes, you will see the **Installation Summary** screen again. This time you should see confirmation for all satellites your dishes are pointed at, and “Satellite reception verified.” You should also see that the switch(es) in your system has been correctly identified.
Refer to the DishPro wiring diagrams for examples of installation summary screens.
14. Press **CANCEL** to exit this menu, and then **Cancel** to exit the **Point Dish/Signal** screen. If you have any other receivers in your system, make sure you run **Check Switch** on each of them, and allow each to take the software upgrade, as needed.

DishPro Wiring Diagrams

DISH 500, One DishPro Twin LNBF, Two DishPro Receivers



This diagram leaves out grounding to be clear. Make sure you ground the system per the *National Electrical Code* (NEC) and all local electrical codes.

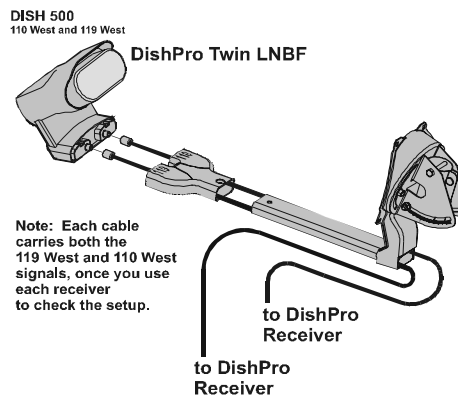

When you set up your system following this diagram and run **Check Switch** the **Installation Summary** screen should look similar to the one shown below.



DISH 500, One DishPro Quad LNBF, Four DishPro Receivers



This diagram leaves out grounding to be clear. Make sure you ground the system per the *National Electrical Code* (NEC) and all local electrical codes.

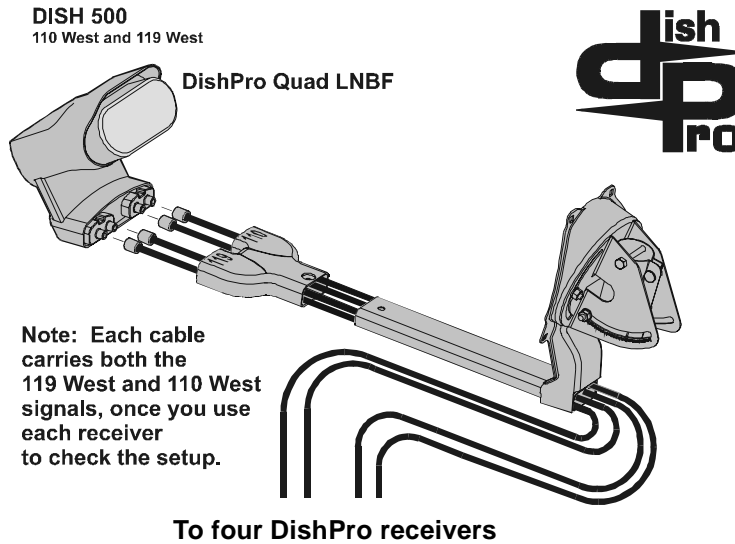

When you set up your system following this diagram and run **Check Switch** the **Installation Summary** screen should look similar to the one shown below.



DISH 500 with a DishPro Twin LNBF, One DISH 300 with a DishPro LNBF, DP34 Switch, Four DishPro Receivers



This diagram leaves out grounding to be clear. Make sure you ground the system per the *National Electrical Code* (NEC) and all local electrical codes.

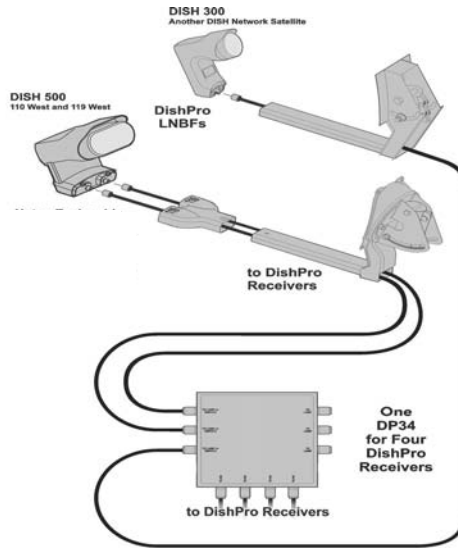

When you set up your system following this diagram and run **Check Switch** the **Installation Summary** screen should look similar to the one shown below.



Two Dishes, Three Single-Output DishPro LNBs, Three Cables, DP34 Switch, Four DishPro Receivers



This diagram leaves out grounding to be clear. Make sure you ground the system per the *National Electrical Code (NEC)* and all local electrical codes.

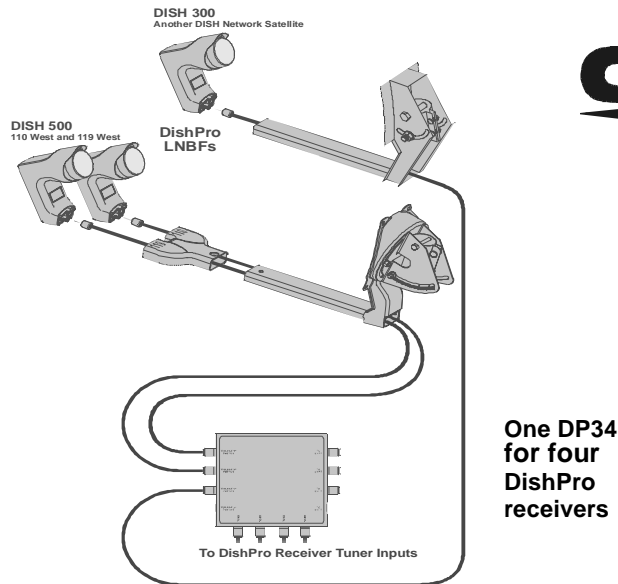

When you set up your system following this diagram and run **Check Switch** the **Installation Summary** screen should look similar to the one shown below.



Two Dishes, One DishPro Twin LNBF, One DishPro Single LNBF, One DishPro Compliant Splitter, Two DishPro 21 Switches, Two Receivers



This diagram leaves out grounding to be clear. Make sure you ground the system per the *National Electrical Code* (NEC) and all local electrical codes.

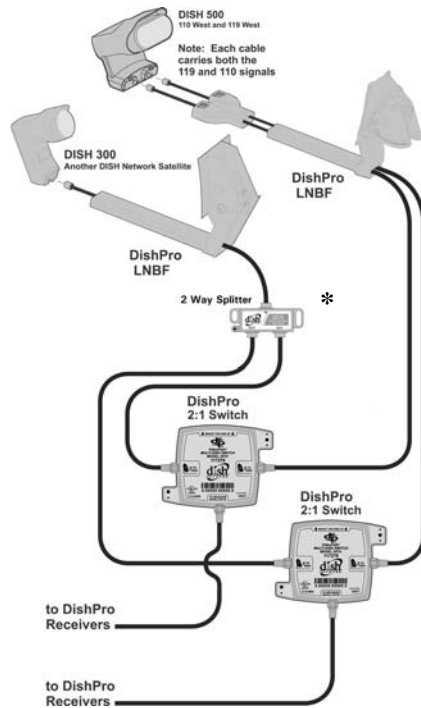

* When using a DishPro compliant splitter to split the signal from a DishPro single LNBF, the receiver whose DP21 switch is connected to the passing side of the splitter must be plugged into a live power outlet at all times. If not, the DishPro single LNBF will not have any power and will not be able to provide satellite signal to the other receiver.

When you set up your system following this diagram and run **Check Switch** the **Installation Summary** screen should look similar to the one shown below.



Two Dishes, Two DishPro Single LNBFs, Two DishPro Compliant Splitters, Two DishPro 21 Switches, Two Receivers



This diagram leaves out grounding to be clear. Make sure you ground the system per the *National Electrical Code (NEC)* and all local electrical codes.

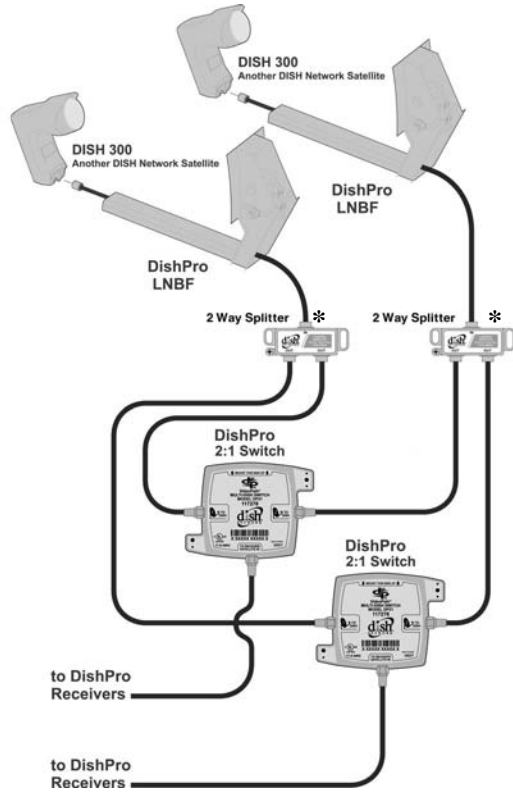

* When using a DishPro compliant splitter to split the signal from a DishPro single LNBF, the receiver whose DP21 switch is connected to the passing side of the splitter must be plugged into a live power outlet at all times. If not, the DishPro single LNBF will not have any power and will not be able to provide satellite signal to the other receiver.

When you set up your system following this diagram and run **Check Switch** the **Installation Summary** screen should look similar to the one shown below.



One DISH 500 with a DishPro Twin LNBF, One DISH 300 with a DishPro Single LNBF, and One DP21 Switch

This diagram leaves out grounding to be clear. Make sure you ground the system per the *National Electrical Code* (NEC) and all local electrical codes.

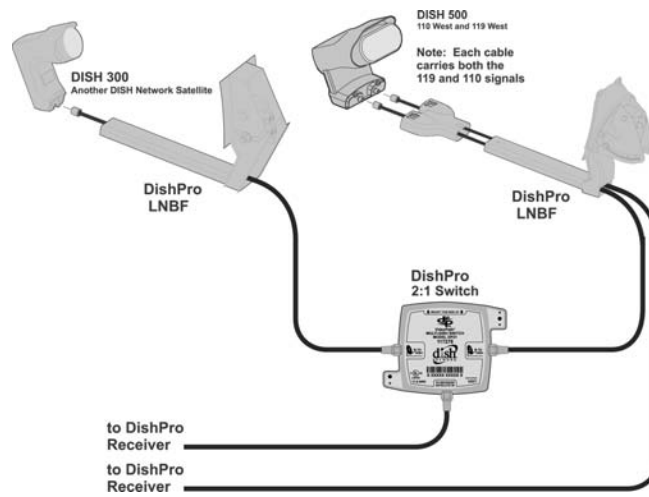

Note: This setup supports only one receiver from three satellite locations and the other receiver from only two satellite locations.

Running Coaxial Cable

- Using the shortest path possible, run the coaxial cable(s) from the ground block or switch to the satellite receiver(s). Do *not* kink or pinch any cable. Cables should be bent *only* in gentle curves.



Do *not* use a longer cable between the satellite dish and the receiver than is specified in the DishPro or Legacy system installation instructions. If your system requires more cable than the limit specified in these installation instructions, you should consider having the system professionally installed.

- Put a drip loop in each cable at a point before it enters the building. A drip loop allows moisture to drip from the cable before it runs into the building.

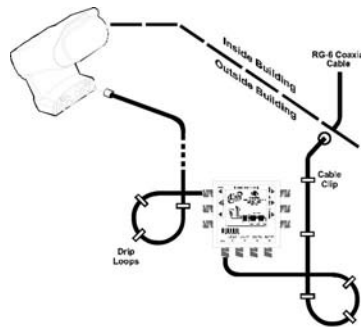

FOR EXAMPLE ONLY



Before drilling any holes in the wall or roof of your building, make sure that there are no wires or pipes in the area of the holes. If you are not comfortable doing this, contact a professional in your area. Make sure that you follow all safety instructions and building codes.

- Locate each receiver inside the building, against or near an outside wall. Then drill a hole through the outer wall to pass a cable inside the building. If a receiver is located in an interior room, run a cable through the outside wall, and into an attic, basement, or crawl space in order to reach the receiver.
- Seal all holes that you drill in the building with silicone or other weather-proof sealant after installation. Once each cable is inside the building, you may attach it to a wall receptacle or directly to a receiver.



Tighten the back panel coaxial cable connections *only* by hand. Using a wrench may over-tighten the connections, causing damage. Such damage is *not* covered by the Limited Warranty in the *User Guide* that came with the system.

Connecting the Receiver to a Phone Line

You *must* keep the receiver connected to an active telephone line. Otherwise, you may not be able to order pay per view programs or use all of the Dish Interactive features. Run a telephone cable with a standard RJ-11 connector from the receiver's back panel **PHONE JACK** to an active telephone connection.

Note: You *may* be able to use a wireless telephone extender. However, this may *not* support all the features of some receivers, such as Caller ID.

Note: If you have a Digital Subscriber Line (DSL), you may have to install a DSL filter between the receiver's back panel **PHONE JACK** and the telephone wall jack to successfully connect with the DISH Network. You can obtain a filter from your DSL provider.

You *must* also set up the receiver for your telephone system (touchtone or rotary/pulse), and set a telephone number prefix, if you need a prefix to make an outside call.

1. Display the **Installation and Setup** menu (press MENU then 6-1-4).
2. Select the **Telephone System** option to display the **Telephone System Setup** menu.



3. Select the **Touch Tone** or the **Rotary/Pulse** option in the **Phone Type** list.

Note: Usually, you need a telephone number prefix only for business installations. For most residential installations, all you need to do is set the telephone system type. The default setting of **No Prefix needed** will allow correct dialing. If this is the case, select the **Save** option to save the above setting, and stop here. If you do need to set a prefix, then instead of selecting the **Save** option, go on to step 4.

4. Move the highlight to the **Outside Line Prefix** list. Press the **SELECT** button to select the highlighted option.

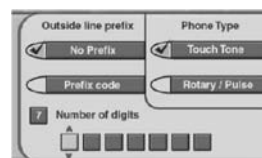

5. Select one of the following:
 - If you do not need to dial a prefix, select the **No Prefix** option.
 - If you need to dial a prefix (for example, dial 9 to get an outside line), select the **Prefix Code** option. The receiver displays the same number of boxes (highlighting the first box) where you must enter the digits. Use the Number Pad to enter the prefix code. As you enter each number, the highlight moves to the next box.
6. Move the highlight to the **Save** option. Press the **SELECT** button to save the settings.

Notes

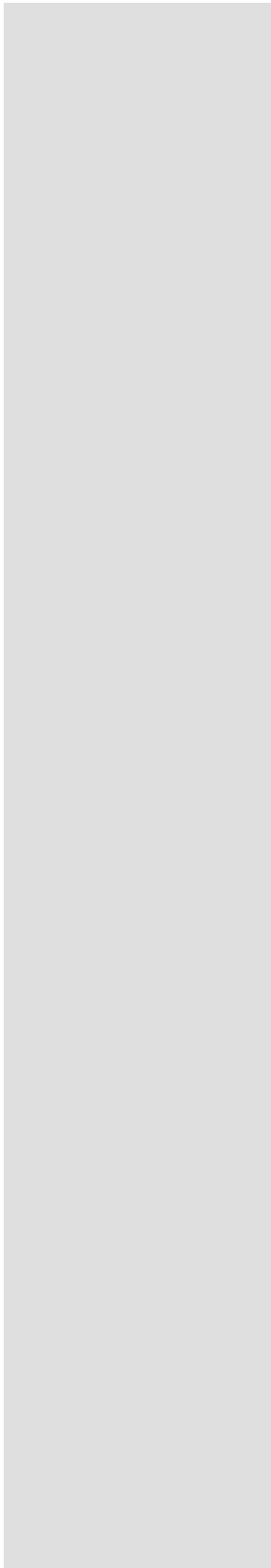

Chapter 5

Reference

TROUBLESHOOTING TABLES

Use these tables if you have problems using the system *before* calling the Customer Service Center. Many problems arise from misunderstandings of how the system works, especially when you are just becoming familiar with it. These tables cover many problems, usually with a simple solution for each one. To solve a particular problem, do the following:

1. Review the section in this *Guide* that relates to the problem.
2. If you cannot find a solution, then find the section in the following tables that relates to the problem.
 - Read the *What's Happening* column until you find the problem.
 - Read the information in the *Possible Reason* column.
 - Try each of the suggested solutions in the *What to Do* column.
3. For more information, call the Customer Service Center at 1-800-333-DISH (3474).

Note: Before calling the Service Center, have ready the date of purchase and either your customer account number, the receiver conditional access number, or the receiver model number. Display the *Important System Information* menu to find these numbers (See *Ordering your Programming* on page 2). Also, write down any error messages that the receiver displays on the television screen.

ON-SCREEN MESSAGES

This table describes some on-screen messages in the order of their *message numbers*. Find the message number in the upper right corner of the message displayed on your TV screen, and then find the matching number in this table.

Message Number	Possible Reason	What to Do
001	<ul style="list-style-type: none"> There may be a problem with the multi-dish switch. 	<ul style="list-style-type: none"> Check the coaxial cables and their connections to and from the multi-dish switch. Make sure that all required cables are in place, and check that all cable connections are tight and dry (for outdoor cables). If this does not work, call the Customer Service Center for help.
002	<ul style="list-style-type: none"> Heavy rain, snow, or cloud cover may be interfering with transmission of the satellite signal, or there may be other interference. 	<ul style="list-style-type: none"> Note the local weather conditions. Remove any snow or other debris which may have collected on the satellite dish. Make sure that the satellite dish has a clear line of sight to the satellite. Check whether branches or leaves have grown into the line of sight. Make sure that the satellite dish is aimed at the satellite. Check the strength of the signal using the Point Dish/Signal menu. Consult your installer to re-aim the dish, if necessary, to obtain the strongest possible signal.
003, 004	<ul style="list-style-type: none"> The wrong type of coaxial cable may be used in the system, or the cable run length may be too long. Or, there may be a problem with the multi-dish switch. 	<ul style="list-style-type: none"> Make sure the system uses RG6 coaxial cable; if not, call your dealer or installer. Check the dish-to-receiver cable run length; if it is over 100 feet, call your dealer or installer. Check the coaxial cables and their connections to and from the multi-dish switch. Make sure that all required cables are in place, and check that all cable connections are tight and dry (for outdoor cables). If this does not work, do the Check Switch test.
005	<ul style="list-style-type: none"> The receiver may not yet have been authorized. The satellite dish may have moved so that it is no longer picking up the satellite signal. The cable connections may have loosened or have moisture inside. There may be an interruption of the satellite signal. 	<ul style="list-style-type: none"> If you have authorized the receiver, wait a few minutes to see if the message is removed. Make sure that all required cables are in place, and check that all cable connections are tight and dry (for outdoor cables). Make sure that the satellite dish has a clear line of sight to the satellite. Check whether branches or leaves have grown into the line of sight. Check that the Signal Strength bar in the Point Dish/Signal menu is green and displays the word Locked. If not, contact your installer to re-aim the satellite dish. If you have not authorized the receiver, call the Customer Service Center for help.
006	<ul style="list-style-type: none"> The receiver may not be connected to an active telephone line. The credit limit may have been suspended. 	<ul style="list-style-type: none"> You <i>must</i> connect the receiver to an active telephone connection at all times. If you install two or more receivers, you <i>must</i> connect <i>each</i> receiver to an active telephone connection at <i>all</i> times. Review your pay per view purchases to check the credit limit.
008	<ul style="list-style-type: none"> Maybe the receiver is connected to a DSL (Digital Subscriber Line) phone line. 	<ul style="list-style-type: none"> Install a DSL filter between the receiver and the telephone wall jack. You can obtain the filter from your DSL provider.
011, 012	<ul style="list-style-type: none"> Viewers in specific areas are prohibited from watching certain programs. <i>For example</i>, viewers who live close to a particular football stadium may be prohibited from watching football games that are played in that stadium. 	<ul style="list-style-type: none"> Remember that the program providers specify which programs are “blacked out” for which viewers, <i>not</i> DISH Network™.

Message Number	Possible Reason	What to Do
013, 014	<ul style="list-style-type: none"> You may have tried to tune to a program on a channel which you have not bought. 	<ul style="list-style-type: none"> You <i>must</i> buy a channel <i>before</i> you can tune to a program on that channel. Call the Customer Service Center to buy the channel, or if you believe this message was displayed by mistake.
015	<ul style="list-style-type: none"> You may have just plugged in the receiver, and it is acquiring the satellite signal. Or, the receiver may have temporarily lost the signal. 	<ul style="list-style-type: none"> Wait a few minutes to see if the message is removed. Make sure that all required cables are in place, and check that all cable connections are tight and dry (for outdoor cables). Make sure that the satellite dish has a clear line of sight to the satellite. Check whether branches or leaves have grown into the line of sight. Check that the Signal Strength bar in the Point Dish/Signal menu is green and displays the word Locked. If not, contact your installer to re-aim the satellite dish.
018	<ul style="list-style-type: none"> The receiver may not be connected to an active telephone line. The credit limit may have been exceeded. 	<ul style="list-style-type: none"> You <i>must</i> connect the receiver to an active telephone connection at all times. If you install two or more receivers, you <i>must</i> connect <i>each</i> receiver to an active telephone connection at <i>all</i> times. Review your pay per view purchases to check the credit limit. Call the Customer Service Center for help checking the credit limit, and/or to get authorization to make a purchase.
022	<ul style="list-style-type: none"> The receiver may not yet have been authorized. The satellite dish may have moved so that it is no longer picking up the satellite signal. The cable connections may have loosened or have moisture inside. There may be an interruption of the satellite signal. 	<ul style="list-style-type: none"> If you have authorized the receiver, wait a few minutes to see if the message is removed. Make sure that all required cables are in place, and check that all cable connections are tight and dry (for outdoor cables). Make sure that the satellite dish has a clear line of sight to the satellite. Check whether branches or leaves have grown into the line of sight. Check that the Signal Strength bar in the Point Dish/Signal menu is green and displays the word Locked. If not, contact your installer to re-aim the satellite dish. If you have not authorized the receiver, call the Customer Service Center for help.
026	<ul style="list-style-type: none"> The receiver may have temporarily lost the satellite signal. 	<ul style="list-style-type: none"> Wait a few minutes to see if the message is removed. Make sure that all required cables are in place, and check that all cable connections are tight and dry (for outdoor cables). Make sure that the satellite dish has a clear line of sight to the satellite. Check whether branches or leaves have grown into the line of sight. Check that the Signal Strength bar in the Point Dish/Signal menu is green and displays the word Locked. If not, contact your installer to re-aim the satellite dish.
028	<ul style="list-style-type: none"> The receiver may need to get new software before you can use it to order pay per view programs. 	<ul style="list-style-type: none"> Turn the receiver off. Doing this allows the receiver to "download" new software via the satellite signal. The download may take several minutes; do <i>not</i> disturb or unplug the receiver during this time. When the download is done, you will be able to use it to order pay per view programs.
032	<ul style="list-style-type: none"> You may have tried to set a <i>VCR Event Timer</i> without having set up the receiver to control the VCR. 	<ul style="list-style-type: none"> You <i>must</i> set up the receiver to control the VCR <i>before</i> you can set a <i>VCR Event Timer</i>. See the <i>Using the System</i> for instructions.
059	<ul style="list-style-type: none"> You may have tried to close an installation menu without having done the Check Switch test. 	<ul style="list-style-type: none"> If your setup includes a multi-dish switch, you <i>must</i> do the Check Switch test.
060	<ul style="list-style-type: none"> You may have aimed the satellite dish at one satellite, but selected the option for another satellite on the Point Dish/Signal menu. 	<ul style="list-style-type: none"> Make sure that you have selected the option for the right satellite on the Point Dish/Signal menu. Make sure that the cable(s) for the satellite you have selected are connected to the LNBF that receives signals from that satellite. Re-aim the satellite dish at the right satellite.

Chapter 5

Reference

Message Number	Possible Reason	What to Do
061	<ul style="list-style-type: none"> You may have set up the receiver to accept a transmission (a "download") of the latest operating software via the satellite signal. 	<ul style="list-style-type: none"> It is <i>very</i> important for the receiver to get the latest operating software, so let the receiver do so. The "download" may take several minutes. <i>Do not</i> disturb or unplug the receiver during this time.
074	<ul style="list-style-type: none"> The receiver gives you three chances to enter the correct password. If you fail to do so, the receiver "times out" and will not allow you to try again for several minutes. 	<ul style="list-style-type: none"> Wait a few minutes and then try again to enter the password. Note: The "time out" feature is designed to prevent someone from trying password after password until he or she happens to guess the right one and so gains unauthorized access to the receiver.
078, 079, 080	<ul style="list-style-type: none"> You may not have connected the receiver to an active telephone line. Or, the telephone line may be defective. Maybe the receiver is connected to a DSL (Digital Subscriber Line) phone line. 	<ul style="list-style-type: none"> Connect the receiver to an active telephone line. Make sure that the telephone line to which you connect the receiver is working properly. Note: To be able to order pay per view programs, you <i>must</i> keep the receiver connected to an active telephone line at all times. If your setup includes more than one receiver, this applies to <i>each</i> receiver. The receiver uses the telephone line to make toll-free calls, usually in the middle of the night, to send information to the Customer Service Center. Install a DSL filter between the receiver and the telephone wall jack.
093	<ul style="list-style-type: none"> You may have set up the receiver to reset itself back to the "factory defaults," <i>that is</i>, the settings it had when it was shipped from the factory. 	<ul style="list-style-type: none"> If you want to reset the receiver to its factory default settings, select the Yes option. If not, select the No option.

DISHPRO TWIN LNBF

What's Happening	What's Wrong	What You Can Do
When you run Check Switch, you do not see "Twin" identified as a Device or LNB. All entries show "X"s.	<ul style="list-style-type: none"> The DishPro Twin LNBF may not be properly connected. Cables may be too long, over 200 feet. Cables may not be rated for 2150 MHz. You may have DishPro Adapter installed on a DishPro receiver. May have a non-DishPro switch or LNB or incompatible accessory device* in the system. 	<ul style="list-style-type: none"> Check all cable connections in your system and run Check Switch again. Make sure cable length between receiver and DishPro Twin does not exceed 200 feet. Rerun check switch. Make sure cable is rated for 2150 MHz. Rerun check switch. Remove the DishPro Adapter; this device is only for non-DishPro receivers. Rerun check switch. Remove any non-DishPro switches/LNBs or incompatible accessory devices* from the system. All LNBs and switches must be DishPro. Rerun check switch.
When you run Check Switch, you see "Twin" identified as the Device/LNB and Satellite shows "Conn" but you do not see "Satellite Reception Verified".	<ul style="list-style-type: none"> The DishPro Twin LNBF is connected but no satellite signal is present. 	<ul style="list-style-type: none"> Check the point dish/signal screen to confirm you have satellite signal. If not, check your dish antenna to ensure the DishPro Twin is installed properly, the dish is pointed/peaked on the satellite signal and there is nothing blocking the signal path to the dish. Rerun check switch.
When you run Check Switch, you see "Satellite Reception Verified" but you see "Feed" instead of "Twin" identified as the Device/LNB.	<ul style="list-style-type: none"> The DishPro Twin is connected but something in the system may be blocking the switch commands. 	<ul style="list-style-type: none"> Check the cable path between the DishPro Twin and the receiver and remove any incompatible accessory devices*. Rerun check switch.

What's Happening	What's Wrong	What You Can Do
When you run Check Switch, you do not see "Twin" identified as a Device or LNB, but odd transponders are detected only on one satellite.	<ul style="list-style-type: none"> You may have DishPro Adapter installed on a DishPro receiver. May have a non-DishPro switch or LNB in the system 	<ul style="list-style-type: none"> Remove the DishPro Adapter; this device is only for non-DishPro receivers. Rerun check switch. Remove any non-DishPro switches/LNBs from the system. All LNBs and switches must be DishPro. Rerun check switch.
When you run Check Switch, you see "Twin" identified as the Device/LNB but you only have signal confirmed from one satellite.	<ul style="list-style-type: none"> The DishPro Twin LNBF is connected but the dish may not be pointed to receive signal from both 110 and 119 satellites. 	<ul style="list-style-type: none"> If the check switch summary screen shows "119 W" on Dish Input 2, you need to point you dish 9 degrees to the east and reapeak your dish. Rerun check switch. If the check switch summary screen shows "110 W" on Dish Input 1, you need to point you dish 9 degrees to the west and reapeak your dish. Rerun check switch. Make sure the skew setting is correct for a Dish 500 installation at your zip code. Rerun check switch.
When you run Check Switch, you see "Twin" identified as a Device or LNB, but only odd transponders are detected.	<ul style="list-style-type: none"> Cables may not be rated for 2150 MHz. 	<ul style="list-style-type: none"> Make sure cable is rated for 2150 MHz and all accessory devices are compatible. Rerun check switch.
Getting receiver messages that signal is lost or being acquired	<ul style="list-style-type: none"> Check the weather conditions to see if heavy rain or snow could be temporarily block the signal. Check for any obstructions in way of the dish like new growth on trees 	<ul style="list-style-type: none"> Wait for weather to clear up and restore signal. Clear obstructions from the signal path.

* Compatible accessory devices must pass 2150 MHz signals, 22 KHz signals both directions (per DiSEqC 2.0 specifications), and pass DC power.

USING THE REMOTE CONTROL

What Is Happening	Possible Reason	What to Do
You cannot find the remote control.	<ul style="list-style-type: none"> N/A 	<ul style="list-style-type: none"> Use the receiver front panel Control Buttons to control the receiver until you find the remote. If the remote control is permanently lost or too damaged to use, call the Service Center to order a replacement.
When you press a button on the remote control, the receiver does not do what you expect.	<ul style="list-style-type: none"> The remote control may be missing batteries, the batteries may be incorrectly placed in the remote, or the batteries may be weak or dead. The remote control address may be incorrect. 	<ul style="list-style-type: none"> If the batteries are missing or dead, insert fresh AAA-size batteries. If the remote has fresh batteries, check whether they are placed according to the label diagram. If not, remove them and place correctly. If you are using a DISH Netwrok 4-service database remote control unlike the remote control which came with your receiver, open the Important System Information screen and press the RECORD button on your remote control.
When you press the remote control Power button to turn the receiver ON, the receiver front panel Power light does not light up.	<ul style="list-style-type: none"> Other lights are too bright. Remote control not operating properly or the batteries are weak or dead. The receiver power cord not plugged into a power outlet, or there may be a problem with the power. 	<ul style="list-style-type: none"> Try other remote control buttons to see if the receiver is responding. Replace the remote batteries with fresh ones. Check that the receiver power cord is not damaged, and that the plug is inserted correctly into the outlet.

HEARING A PROGRAM

What Is Happening	Possible Reason	What to Do
The receiver front panel Power light is on and there is a good picture on the TV set, but you do not hear any sound.	<ul style="list-style-type: none"> You may have muted the sound, or set the volume so low that you cannot hear it. 	<ul style="list-style-type: none"> Check the volume level on the TV or audio device. Turn off the mute or turn up the volume, as required.
You hear a foreign language with a program.	<ul style="list-style-type: none"> You may have set the receiver to an alternate audio language. 	<ul style="list-style-type: none"> Use the Alternate Audio Language menu to select the language that you prefer.

WATCHING A PROGRAM

What Is Happening	Possible Reason	What to Do
The receiver front panel Power light is on, but the TV image: is black (no picture), is frozen, has breakups, has "snow," or shows small squares of various colors.	<ul style="list-style-type: none"> The TV set may not be working properly. If the TV and the receiver are working properly, there may be interference with the satellite signal. The TV may be wired to the wrong input. 	<ul style="list-style-type: none"> Make sure that the TV set is plugged into an electrical outlet. Make sure the outlet has electrical power. Make sure that the TV is turned on. Make sure that the TV is tuned to channel 3 or 4 (whichever works best in your area) and that the receiver modulator setting is set to the same channel as the TV. Make sure that the TV brightness and contrast are adjusted correctly. Make sure that the TV is connected properly to the receiver. Make sure that the TV's text mode and closed captioned features are turned off. Check that the system has been installed correctly. Make sure that all required coaxial cables are in place, and check that all cable connectors are tight and dry (for outdoor cables). Make sure that the satellite dish has a clear line of sight to the satellite. Check whether branches or leaves have grown into the line of sight. Make sure that the satellite dish is aimed at the satellite. Check the strength of the signal using the Point Dish and Signal Strength menu. Consult your installer to re-aim the dish, if necessary, to obtain the maximum possible signal strength. Note the local weather conditions. Heavy rain, snow, or cloud cover may be interfering with transmission of the satellite signal. Remove any snow or other debris which may have collected on the satellite dish.
The receiver front panel Power light is on, and there is a picture on the TV screen, but the picture: has sparkles or is grainy, has a herringbone pattern, lacks color or vertical hold, or wobbles, or looks "washed out" or fuzzy.	<ul style="list-style-type: none"> The TV set may not be working properly. There may be a strong local broadcast on the same channel, or a channel adjacent to the one to which the TV is tuned. There may be interference from other nearby electrical devices (such as cellular telephones, computers, microwave ovens, radios, stereos, or TVs). 	<ul style="list-style-type: none"> Make sure that the TV brightness and contrast are adjusted correctly, and that the TV is working properly. Make sure that the TV is connected properly to the receiver. Check other nearby electrical devices as possible sources of interference. Check that all required coaxial cables are in place. Check for moisture or water leaking into all connections. Dry them out if needed, then seal them with coaxial cable sealant. Check the dish-to-receiver cable run length; if it is over 200 feet, call your dealer or installer.
A "black box" fills almost all of the TV screen.	<ul style="list-style-type: none"> You may have turned on the Closed Captioned feature on the TV, and put that feature into Text mode. 	<ul style="list-style-type: none"> Using the TV remote control and/or menus displayed by the TV (<i>not</i> the receiver remote control or the menus displayed by the receiver), turn off the closed captioned feature.

USING THE MENUS

What Is Happening	Possible Reason	What to Do
You were using a menu, and it suddenly closed.	<ul style="list-style-type: none"> The receiver has a time-out feature that closes any menu after several minutes of no activity. This will discard any changes you have made, but otherwise does no harm to the receiver. 	<ul style="list-style-type: none"> Start over again.

USING THE PROGRAM GUIDE OR THE BROWSE BANNER

What Is Happening	Possible Reason	What to Do
In the Program Guide , some channels have a red background.	<ul style="list-style-type: none"> Red means that you have not bought the program. You <i>must</i> buy a channel before you can tune the receiver to it. 	<ul style="list-style-type: none"> If you want to buy a channel, call the Customer Service Center at 1-800-333-DISH (3474).
You try to display future programs in the Program Guide or Browse Banner , but find you cannot.	<ul style="list-style-type: none"> The Program Guide and Browse Banner can display programs scheduled for an extended, but not unlimited time beyond the present. 	<ul style="list-style-type: none"> Try displaying the Program Guide again later. By that time, it may show programs for the time and date you want. Turn the receiver off for about ten minutes.
You try to display programs that have ended in the Program Guide or Browse Banner , but find you cannot.	<ul style="list-style-type: none"> The Program Guide and Browse Banner can display <i>only</i> programs that have not yet ended. These features <i>cannot</i> display a time earlier than the present. 	<ul style="list-style-type: none"> Contact the program providers for details on past programs.
When you are using the Program Guide or Browse Banner , some channels are missing.	<ul style="list-style-type: none"> You may have applied a Favorite List other than the list named All Chan. You may have set up the Program Guide so that when the receiver is locked, the Guide hides adult channels. If your setup includes a multi-dish switch, you may need to do the Check Switch procedure. 	<ul style="list-style-type: none"> You can change the applied Favorite List while using the Program Guide, by pressing the remote control Guide button. You can choose another custom Favorite List, the All Chan list, which includes all of the channels, or the All Sub list, which includes all subscribed channels. Unlock the receiver for the Program Guide to display adult channels. Do the Check Switch procedure (see the installation instructions for details).

USING LOCKS

What Is Happening	Possible Reason	What to Do
You set a lock (<i>for example</i> , a lock on programs by ratings), but the lock does not take effect.	<ul style="list-style-type: none"> You may not have locked the receiver. 	<ul style="list-style-type: none"> You <i>must</i> lock the receiver to apply any lock that you have set.
You forgot the password, so that you are unable to unlock the receiver.	<ul style="list-style-type: none"> NA 	<ul style="list-style-type: none"> If you forget your password, you will need to speak with a Customer Service Representative. If you have a Personal Identification Number (PIN), you will need to give it to the Customer Service Representative. See page 44 for information on PINs.

CHANGING CHANNELS

What Is Happening	Possible Reason	What to Do
<p>You enter a desired channel number. The channel changes, but the new channel is not exactly the channel you entered. You are scanning up or down through the channels, and the receiver is skipping channels that you know you have bought.</p>	<p>You may have made a mistake entering the channel number, or the channel number you entered may be invalid.</p> <p>If so, the channel displayed is the closest possible to the channel you entered.</p> <p>If you entered the number for a channel that you have not bought, the receiver will change to the channel and allow you to buy the channel or display a message.</p> <p>If a Favorite List other than All Chan is applied, the receiver will skip channels that are not on the applied list.</p> <p>If you have set up the Program Guide to hide adult channels and the receiver is locked, the receiver will skip such channels.</p>	<p>Carefully retry entering the channel number you want.</p> <p>Press the remote control Recall button to return to the previous channel number. Select All Chan as the active Favorite List.</p> <p>Unlock the receiver so that it does not skip adult channels.</p> <p>If you want to buy a channel, call the Customer Service Center.</p>

USING FAVORITE LISTS

What Is Happening	Possible Reason	What to Do
<p>You press the remote Guide button while the Program Guide is displayed. You find that you can apply <i>only</i> the All Chan list or the All Sub list.</p>	<p>If you have not added channels to any custom Favorite List, you will be able to apply <i>only</i> the All Chan list or the All Sub list.</p>	<p>You <i>must</i> add channels to a custom Favorite List <i>before</i> you can apply it.</p>
<p>You try to change the All Chan list or the All Sub list. The receiver displays an ERROR message.</p>	<p>The receiver will <i>not</i> allow you to change the All Chan list or the All Sub list.</p>	<p>Choose another list to change.</p> <p>Note: You <i>can</i> change the All Sub list by changing what channels you buy.</p>
<p>You try to apply an empty Favorite List. The receiver displays an ERROR message.</p>	<p>The receiver will not allow you to apply an empty list.</p>	<p>Choose another list to apply, or add at least one channel to the empty list.</p>
<p>A Favorite List does not show channels that you know you have added to it.</p>	<p>If you have set up the Program Guide to hide adult channels and the receiver is locked, the Favorite List will not show such channels.</p>	<p>Unlock the receiver for the list to show adult channels.</p>

BUYING A PAY PER VIEW PROGRAM

What Is Happening	Possible Reason	What to Do
Someone orders a pay per view program without your permission.	You may have been away from the receiver, and someone else used it.	Lock the purchase of pay per view programs. <i>Remember that you are responsible for all pay per view purchases, whether or not you authorize such purchases.</i> If you lock pay per view purchases, then anyone who wants to order a pay per view program <i>must</i> enter the password.
You find that you are not able to order a pay per view program.	The receiver may not be connected to an active telephone line. The credit limit may have been exceeded.	You <i>must</i> connect the receiver to an active telephone connection at all times. If you install two or more receivers, you <i>must</i> connect <i>each</i> receiver to an active telephone connection at <i>all</i> times. Review your pay per view purchases to check the credit limit.
You find that you are not able to cancel a pay per view program.	You ordered a pay per view program, and then decided not to watch it.	You <i>cannot</i> cancel an order for a pay per view program, whether it was just ordered or ordered earlier.
Your setup includes more than one receiver. You order a pay per view program, but it does not appear via all of the receivers.	You ordered a pay per view program, and want it to be available via all the receivers in your setup.	If you want to watch a pay per view program on TVs connected to up to six receivers, you must <i>order</i> the program for <i>each</i> receiver but you only <i>pay</i> for the program <i>once</i> .

USING THE TELEPHONE FOR VOICE/DATA/FAX

What Is Happening	Possible Reason	What to Do
While you are making a telephone call, you hear "clicks."	The receiver may have tried to call the Customer Service Center to send pay per view purchase information. When the receiver found that the telephone was busy, it automatically disconnected.	You do not have to do anything. You can always use your telephone line, because the receiver automatically hangs up if it finds the line is busy.
The receiver cannot connect to DISH Network.	Maybe the receiver is connected to a DSL (Digital Subscriber Line) phone line.	Install a DSL filter between the receiver and the telephone wall jack.
You pick up the telephone to make a call, but you do not hear a dial tone.	The receiver was calling the Customer Service Center to send pay per view information. When the receiver found that the telephone was busy, it automatically disconnected.	Hang up, and then pick up the telephone again to get a dial tone.
Your computer or facsimile (FAX) machine tries to send a FAX or modem transmission, but fails.	The receiver was calling the Customer Service Center to send pay per view information. When the receiver found that the telephone was busy, it automatically disconnected. The FAX or modem found that there was no dial tone, and cancelled the transmission.	Resend the FAX or modem transmission.
Your computer or FAX machine was receiving a FAX or modem transmission, but an error occurred.	The receiver may have tried to call the Customer Service Center to send pay per view purchase information during the FAX or mode call. When the receiver found that the telephone was busy, it automatically disconnected. This generated "clicks" that caused an error in the FAX or modem transmission.	Have the sender resend the FAX or modem transmission.

USING EVENT TIMERS

What Is Happening	Possible Reason	What to Do
You try to set up an event timer and the receiver displays a message noting that the program is locked.	You <i>must</i> enter the password <i>before</i> you can create an event timer for a locked program.	To be able to set up an event timer for the program, first enter the password.
You try to set up an event timer and the receiver displays a message noting that the program is a pay per view event.	You <i>must</i> order a pay per view event <i>before</i> you can create an event timer for it.	To be able to set up an event timer for the event, first order it.
You try to set up an event timer, but the receiver displays an Error message giving you the option to delete an event timer that was set up earlier.	You already have set up the maximum number of event timers.	To be able to set up a new event timer, delete one of the event timers you set up earlier.
You set up an event timer, but the receiver does not tune to the channel of the program, or does not record the program.	You may have set up a <i>Reminder Event Timer</i> but what you should have set up is an <i>Auto-Tune Event Timer</i> , or a <i>VCR Event Timer</i> .	Remember that a <i>Reminder Event Timer</i> just reminds you that the program is about to start. An <i>Auto-Tune Event Timer</i> reminds you and tunes the receiver to the channel of the program. A <i>VCR Event Timer</i> reminds you, tunes the receiver, and starts the VCR.
You set up an event timer for a program that is repeated (such as a regularly scheduled program), but the timer does not operate for a showing of the program.	You may have set up a timer with an incorrect frequency.	Remember that a <i>Once</i> event timer operates just one time. A <i>Mon.-Fri.</i> event timer operates Monday through Friday on the same channel at the same time. A <i>Daily</i> event timer does the same, Monday through Sunday. A <i>Weekly</i> event timer operates once a week on the same channel at the same time.
You set up an event timer, but the timer does not operate at all.	The program time may have changed so that the event timer overlapped another event timer. The program time may have changed by more than twenty-four hours.	If the receiver is ON and finds an event timer overlap, it will display the Event Timer Scheduling Conflict menu. You <i>must</i> edit or delete one of the overlapping event timers. No event timer will operate if the program time changes by more than twenty-four hours.
You set up a <i>Once</i> event timer, but the timer operates at a time different from what you expect.	The program time changed.	A <i>Once</i> event timer always operates at the actual time of the program.
You stop the operation of an event timer for one showing of a program that is repeated (such as a regularly scheduled program), but the timer operates for the next showing.	Stopping the event timer applies <i>only</i> to the current showing of the program.	To stop all operations of a repeated event timer, you <i>must</i> delete the event timer. Note: The receiver deletes a <i>Once</i> event timer when it operates.
You are testing a VCR code to see if the receiver controls a VCR. The VCR does not do the test.	The VCR may not be turned ON, there may not be a tape inserted, the tape may not be rewound, or the write-protect tab on the tape may have been removed. The code you are testing may not be valid for the VCR.	Make sure the VCR is turned ON, with a blank tape inserted on which you want to record, that the tape is rewound, and that the write-protect tab on the tape is intact. Try another VCR code from the VCR Codes table. The remote control user guide provides this table.

DEVICE CODES

These tables contain the manufacturer codes for programming the remote to control your VCR when you use timers on your receiver. Every attempt has been made to include all codes. If your VCR brand is not listed or if the codes do not work, the receiver may not be able to use VCR timers.

VCR CODES

Brand	Code
Aiwa	588, 622, 623, 624
Akai	513, 514, 515, 516, 517, 518, 519, 520, 568,
Alba	546
Amstrad	588
ASA	565
Audio Dynamics	594, 600
Broksonic	559
Bush	589
Candle	580, 592, 593
Canon	542, 553, 554
Capehart	543, 546
Citizen	591, 592, 593
Craig	591, 608
Croslex	553
Curtis Mathes	554, 592, 605
Daewoo	534, 545, 546, 547, 593
Daytron	546
DBX	594, 600
Dumont	549
Dynatech	588
Electrohome	609

Brand	Code
Emerson	505, 506, 507, 508, 509, 510, 511, 512, 559, 568, 588, 590, 609, 618
Finlandia	549
Finlux	549, 565, 588
Fisher	548, 549, 584, 588, 608, 610
General Electric (GE)	550, 551, 552, 554, 572, 591, 605
Goldstar	530, 555, 592, 612, 613
Goodmans	585, 589
Go Video	557 558, 620
Granada	549, 581
Grundig	565
Harmon Kardon	530, 569
Hinari	589
Hitachi	536, 537, 538, 539, 540, 541, 553, 588, 595, 596, 597
Instant Replay	553
ITT	518
JC Penney	530, 554, 580, 591, 594, 600, 601
Jenson	560
JVC	561, 562, 563, 564, 592, 594, 600, 601

Brand	Code
Kenwood	562, 581, 592, 594, 600, 601
Lloyd	588
Logik	589
Luxor	518
Magnavox	527, 553, 554, 556, 565, 611
Marantz	530, 554, 565, 585, 592, 594, 600, 601, 603
MEI	554
Memorex	533, 549, 554, 566, 581, 585, 588, 608
MGA	567, 568, 609
Mitsubishi	562, 567, 568, 569, 570, 571, 609
MTC	544, 580, 588
Multitech	588, 589, 591
NAD	573
NEC	530, 531, 532, 562, 592, 594, 599, 600, 601, 602, 603, 604
Olympic	553
Optonica	585
Orion	506, 507
Panasonic	521, 522, 523, 524, 526, 553, 633 554, 598, 614, 628
Pentax	537, 592

Chapter 5

Reference

Brand	Code
Perdio	588
Philco	553, 554, 611
Philips	553, 554, 565, 585
Pioneer	553, 562, 573, 574, 575, 576, 600
Portland	546, 593
Proscan	553, 605
Pulsar	533
Quartz	581
Quasar	553, 554, 577, 578
Radio Shack	607, 608, 609, 610
RCA	525, 526, 527, 528, 529, 537, 553, 591, 605, 606, 615, 630, 631
Realistic	549, 554, 580, 581, 584, 585, 588
Ricoh	502
Saisho	506, 507
Salora	567, 581
Samsung	517, 534, 579, 580, 591
Sansui	532, 544, 562, 600, 621
Sanyo	549, 581, 582, 583, 608
SBR	565
Schneider	589
Scott	508, 559, 590
Sears	548, 549, 581, 584, 608, 610,
Sentra	546

Brand	Code
Sharp	585, 607, 609, 625
Shintom	589
Sony	500, 501, 502, 503, 504
Sylvania	553, 554, 556, 567, 588, 611
Symphonic	588, 594
Tashiko	588
Tatung	586, 594, 601
Teac	588, 594, 601
Technics	553, 554
Teknika	554, 587, 588
TMK	506
Toshiba	534, 535, 567, 590
Totevision	580, 591
Unitech	580
Vector Reaserch	530, 600
Victor	561, 562, 600
Video Concepts	568, 600
Videosonic	591
Wards	527, 554, 580, 585, 588, 589, 590, 591, 607, 608, 609
Yamaha	530, 592, 594, 600, 601
Zenith	500, 501, 533

Appendix A

Installing a DISH Pro Receiver in an Existing System

These instructions guide you through the installation of your new DISH Pro satellite receiver in an existing system where your satellite dish(es) has already been installed and pointed for the strongest possible signal. If your DISH Pro dish antenna(s) is not already installed, you will need to follow the *Installation Instructions* found in *Chapter 4*.

There are two dish antenna systems that are covered by these installation instructions.

- DISH Pro antenna systems which have the DISH Pro logo shown below.



- Legacy antenna systems which *do not* have the DISH Pro logo.

Installation Instructions

1. Connect an RG-6 coaxial cable (see notes below) from the **SAT IN** port on the receiver's back panel to an available port on your switch or LNBF in your existing system. See *Chapter 4* wiring diagrams for appropriate receiver connections in your system. See *Running Coaxial Cabling*. Peel off the blue sticker and affix it to the cable close to where it connect to the **SAT IN** connection on the back of the receiver.

Note: If you are installing a DISH Pro receiver into a system with DISH Pro LNBFs (and/or switches), you can have as much as 200 feet of cable between the LNBF and the receiver. However, you must use only RG-6 coaxial cables rated for 950 to 2150 MHz. Some cables may say "Swept tested for 2150 MHz." If you have any doubt about this, ask your Dish retailer, or look on the container the cable came in. Do not use cable company TV cables or cables from other satellite TV systems not rated for 950-2150 MHz. These other cables may cause signal loss. Do not use existing cables such as RG-59. Also, be sure that any outdoor connections are made using waterproof F-connectors.

Note: If you are installing the DISH Pro receiver into a system with Legacy LNBFs and/or switches (that do not have a DISH Pro logo), you can have as much as 100 feet of cable between the LNBF and the receiver. However, you must use only RG-6 cable - do not use existing cables such as RG-59. Also, be sure that any outdoor connections are made using waterproof F-connectors.

Tip: Using cable labels makes it easy to tell which cables connect to the receiver ports.

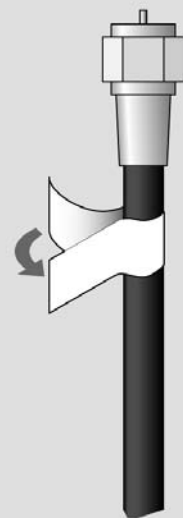

Warning: Tighten all the coaxial cable connections only by hand. Using a wrench may over-tighten the connections, causing damage. Such damage is not covered by the Limited Warranty.

2. Connect a coaxial cable from the **TV SET OUT** connection on your receiver to your television's RF tuner input. Peel off the white sticker and affix it to the cable close to where it connect to the **TV SET OUT** connection on the back of the receiver.
3. Plug in the receiver's power cord. Make sure both the receiver and TV are turned on.
4. You should see the **Point Dish/Signal Strength** menu in the new receiver. If you do not, open the **Main Menu**, by pressing MENU followed by 6-1-1 on the remote.
5. Select **Check Switch**. Select **Test** to run **Check Switch**.
6. When **Check Switch** is complete, you will see an **Installation Summary** screen. If the screen shows the correct switch and the message "Satellite reception verified" for all satellites in your system, go to step 7. If the **Installation Summary** screen does not detect all of the satellites your system should be receiving, check and retighten (by hand) the cable connections between your receiver, LNBFs and switches in your system. Then press **Test** to rerun **Check Switch** again.
7. Select **OK** to return to the **Point Dish/Signal Strength** screen. Then select **Cancel** to exit the **Point Dish/Signal Strength** screen.
8. An **Attention** screen will open asking if the mounting and positioning of your dish is complete with a "Locked" indication in the **Point Dish/Signal Strength** screen. Since your system is already installed and your dish is pointed for the strongest possible signal strength, you can select **Yes**.
9. The receiver will begin taking a software upgrade. You will see the message shown below.

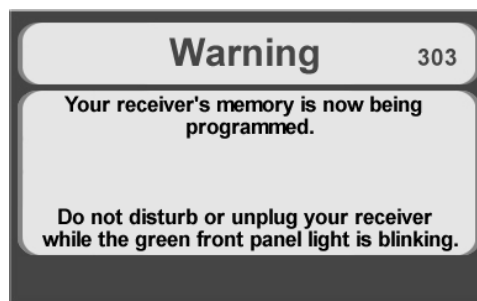

A progress bar at the bottom of the screen will show how the software upgrade is progressing. Once the software upgrade is complete, you will see a second message that the receiver's memory is now being programmed.

This message may disappear, your screen may go blank for a few minutes, and the green light may continue to blink. This is normal and does not indicate a problem with the receiver.

10. When the software upgrade is complete, press VIEW TV and you should now be able to watch TV programming. To activate your programming on this newly installed receiver, call 1-800-333-DISH (3474). See *Chapter 1, Introduction*.

Appendix B

Limited Warranty

JVC COMPANY OF AMERICA warrants this product and all parts thereof, except as set forth below ONLY TO THE ORIGINAL PURCHASER AT RETAIL to be FREE FROM DEFECTIVE MATERIALS AND WORKMANSHIP from the date of original retail purchase for the period as shown below ("the Warranty Period").

PARTS	1 YR	LABOR	1 YR
-------	------	-------	------

THIS LIMITED WARRANTY IS VALID ONLY IN THE FIFTY (50) UNITED STATES OF AMERICA, THE DISTRICT OF COLUMBIA, AND IN THE COMMONWEALTH OF PUERTO RICO.

WHAT WE WILL DO

If this product is found to be defective, JVC will repair or replace defective parts at no charge to the original owner. Such repair and replacement services shall be rendered by JVC during normal business hours at JVC factory service centers. Parts used for replacement are warranted only for the remainder of the Warranty Period. All products and parts thereof may be brought to a JVC factory service center on a carry-in basis except for Television sets having a screen size 25 inches and above which are covered on an in-home basis.

WHAT YOU MUST DO FOR WARRANTY SERVICE

Return your product to a JVC factory service center with a copy of your bill of sale. For your nearest JVC factory service center, please call toll-free: 1-800-252-5722.

If service is not available locally, box the product carefully, preferably in the original carton, and ship, insured, with a copy of your bill of sale plus a letter of explanation of the problem to the nearest JVC Factory Service Center, the name and location of which you can obtain by calling the above toll-free number.

If you have any questions concerning your JVC Product, please contact our Customer Relations Department.

WHAT IS NOT COVERED

This limited warranty provided by JVC does not cover:

1. Products which have been subject to abuse, accident, alteration, modification, tampering, negligence, misuse, faulty installation, lack of reasonable care, or if repaired or serviced by anyone other than a service facility authorized by JVC to render such service, or if affixed to any attachment not provided with the products, or if the model or serial number has been altered, tampered with, defaced, or removed;
2. Initial installation and installation and removal for repair;
3. Operational adjustments covered in the *User Guide*, normal maintenance, video and audio head cleaning;
4. Damage that occurs in shipment, due to act of God, and cosmetic damage;
5. Signal reception problems and failures due to line power surge;

- 6. Video Pick-up Tubes/CCD Image Sensor, Cartridge, Stylus (Needle) are covered for 90 days from the date of purchase;
- 7. Programming fees payable to your service provider if the product is removed for repair or replacement;
- 8. Accessories;
- 9. Batteries (except that Rechargeable Batteries are covered for 90 days from the date of purchase).

There are no other express warranties except as listed above.

THE DURATION OF ANY IMPLIED WARRANTIES, INCLUDING THE IMPLIED WARRANTY OF MERCHANTABILITY, IS LIMITED TO THE DURATION OF THE EXPRESS WARRANTY HEREIN.

JVC SHALL NOT BE LIABLE FOR THE LOSS OF USE OF THE PRODUCT, INCONVENIENCE, LOSS OR ANY OTHER DAMAGES, WHETHER DIRECT, INCIDENTAL OR CONSEQUENTIAL (INCLUDING, WITHOUT LIMITATION, DAMAGE TO TAPES, RECORDS OR DISCS) RESULTING FROM THE USE OF THIS PRODUCT, OR ARISING OUT OF ANY BREACH OF THIS WARRANTY. ALL EXPRESS AND IMPLIED WARRANTIES, INCLUDING THE WARRANTIES OF MERCHANTABILITY AND FITNESS FOR PARTICULAR PURPOSE, ARE LIMITED TO THE WARRANTY PERIOD SET FORTH ABOVE.

Some states do not allow the exclusion of incidental or consequential damages or limitations on how long an implied warranty lasts, so these limitations or exclusions may not apply to you. This warranty gives you specific legal rights and you may also have other rights which vary from state to state.

JVC COMPANY OF AMERICA
DIVISION OF US JVC CORPORATION
41 Slater Drive
Elmwood Park, NJ 07407

REFURBISHED PRODUCTS CARRY A SEPARATE WARRANTY; THIS WARRANTY DOES NOT APPLY. FOR DETAILS OF REFURBISHED PRODUCT WARRANTY, PLEASE REFER TO THE REFURBISHED PRODUCT WARRANTY INFORMATION PACKAGED WITH EACH REFURBISHED PRODUCT.

FOR CUSTOMER USE:

Enter below the Model No. and Serial No. which are located either on the rear, bottom, or side of the cabinet. Retain this information for future reference.

MODEL # _____

SERIAL # _____

PURCHASE DATE: _____

DEALER NAME: _____

Residential Customer Agreement

Effective as of September 1, 2001 until replaced.

THIS DOCUMENT DESCRIBES THE TERMS AND CONDITIONS UNDER WHICH DISH NETWORK WILL PROVIDE ITS SERVICE TO YOU. IF YOU DO NOT ACCEPT THESE TERMS AND CONDITIONS, PLEASE NOTIFY US IMMEDIATELY AND WE WILL CANCEL YOUR SERVICE. IF YOU ARE A NEW DISH NETWORK CUSTOMER, YOUR ACTIVATION OF A DISH NETWORK ACCOUNT AND RECEIPT OF DISH NETWORK SERVICES SHALL CONSTITUTE YOUR ACCEPTANCE OF THIS AGREEMENT AND ITS TERMS AND CONDITIONS WILL BE LEGALLY BINDING UPON YOU.

IF YOU ARE AN EXISTING DISH NETWORK CUSTOMER, YOUR CONTINUED RECEIPT OF DISH NETWORK SERVICES FOLLOWING RECEIPT OR PUBLICATION BY DISH NETWORK ON ITS WEB SITE OF THIS AGREEMENT SHALL CONSTITUTE YOUR ACCEPTANCE OF ITS TERMS AND CONDITIONS, AND, ACCORDINGLY, THEY WILL BE LEGALLY BINDING ON YOU.

Thank you for choosing DISH Network for your television service provider.

DISH Network is happy to answer any questions you may have and to provide you with technical and other customer support through the following toll-free number and email address:

1-800-333-DISH
feedback@echostar.com

or you may write to:

DISH Network
Customer Service Center
P.O. Box 33577
Northglenn, CO 80233

and, for general knowledge, try our website at **www.dishnetwork.com**.

"DISH Network" is a trademark of EchoStar Satellite Corporation.

1. THE DISH NETWORK SERVICE

A. Services Defined. DISH Network offers a wide variety of video and audio programming and other services and we are constantly striving to add new services to our lineup. For purposes of this Agreement the term "Services" shall mean the programming available on DISH Network (whether subscription based or pay per view based) and any other services that we may provide to consumers either now or in the future. For purposes of this Agreement the terms "You" or "Your" refer to you, the DISH Network subscriber.

B. Programming Changes. Except as otherwise set forth in this Agreement, you may change your programming selection at any time by notifying us. A fee may apply to such changes (Change of Service Fee). In addition, you may be charged a fee (Service Access Fee) if you fail to subscribe to one of DISH Network's basic programming packages which include America's Top 50, America's Top 100/CD, America's Top 150, DISH Latino or DISH Latino Dos.

C. Programming Availability. Certain Services transmitted by us, including but not limited to some subscription Services, sporting events and broadcast network Services, may be blacked out in your area of reception. If you circumvent or attempt to circumvent any of these blackouts, you may be subject to legal action. You must be at least 18 years of age, or the applicable age of majority where you reside, in order to receive adult-oriented programming services.

D. Ordering Pay Per View. You may order DISH Network pay-per-view Services by using your on-screen Program Guide and remote control unit to select the movies and other events we offer. To order DISH Network pay-per-view Services, your DISH Network DBS digital receiver must be connected to a telephone outlet. You may also order DISH Network special events and pay-per-view Services over the telephone by calling the Customer Service Center or by using our automated system through the following toll-free number:

1-877-DISH-PPV (347-4778) for ordering movies

A small fee will apply for use of the automated system (Pay-Per-View Automated Fee) or the Customer Service Center (Pay-Per-View Fee).

E. Private Viewing. DISH Network provides Services to you for your private home viewing, use and enjoyment. You agree that the Services provided will not be viewed outside of your private residence. You are permitted to exhibit the Services solely in your private residence and not in any other areas. The Services may not be rebroadcast, transmitted, recorded or performed, nor may admission be charged for listening to or viewing any Services provided by us. If we later determine that you utilized your DISH Network Equipment (including any additional DISH Network receivers) or sold, leased or otherwise gave possession of the same to a third party who you knew or reasonably should have known intended to use it to permit the viewing of the Services in a commercial establishment or any other area open to the public, we may terminate the Services and in addition to all other applicable fees, you agree to pay us the difference between the price actually paid for the Services and the full commercial rate for such Services, regardless of whether we have or had the commercial rights to such Services. The payment of that amount and/or the termination of Services shall not prejudice our ability to exercise any other rights and remedies we may have under this Agreement, at law, in equity, or otherwise.

F. Additional Receivers. DISH Network will allow you to place up to five additional receivers on your account. Each additional receiver would be authorized to receive the same Services as your initial receiver. DISH Network will charge you a reduced monthly fee (Additional Receiver Authorization Fee) for each additional receiver added to your account. This option is only available if your initial DISH Network receiver and all additional receiver(s) are located at the same residence and are continuously connected to the same telephone line. If you desire to receive Services at two different locations, you must open a separate account for each location. You agree that you will not directly or indirectly use a single account for the purpose of authorizing Services for multiple DISH Network receivers that are not all located in the same residence and connected to the same phone line. If we later determine that you did, we may terminate your Services and, in addition to all other applicable fees, you agree to pay us the difference between the amounts actually received by us and the full retail price for the Services authorized for each DISH Network DBS receiver on the account, whether owned by you or not. The payment of that amount and/or the termination of Services shall not prejudice our ability to exercise any other rights and remedies we may have under this Agreement, at law, in equity, or otherwise.

G. Changes in Services offered. DISH Network reserves the right to change the Services that we offer, and our prices or fees related to such Services at any time. If the change affects you, we will provide you notice of the change and its effective date. The notice may be provided on your billing statement or by other communication permitted under Section 9B. In the event of a change in the contents of any programming, programming packages or other Services, you understand and agree that we have no obligation to replace or supplement the programming, programming packages or other Services previously offered that have been deleted, rearranged or otherwise changed. You further understand and agree you will not be entitled to any refund because of a change in the contents of any programming, programming packages, or other Services previously offered.

H. Multi-Month Subscriptions. For multi-month subscriptions, you may downgrade the Services only at the time of renewal. You may not downgrade the Services during the term of the multi-month subscription.

I. Fees for Receivers that Independently Support Multiple Televisions. Additional fees may apply for a receiver which supports independent viewing of programming on multiple televisions.

2. BILLING POLICIES AND PAYMENTS FOR SERVICES

A. You agree to pay all amounts billed for Services and to pay all taxes, fees and other charges, if any, which are now or may in the future be assessed on the Services you receive from us. Unless you prepay for a multi-month subscription to Services, we will bill you each month, in advance, for Services ordered by you or anyone who uses your DISH Network Equipment, whether with or without your permission, until you cancel the Services. The bills you receive will show the total amount due, the payment due date, payments, credits, purchases and other charges to your account.

B. You agree to pay us in full monthly by the payment due date for the Services and for any other charges due us, including any fees set forth in this Section 2. Payment of your bill after the due date will result in you paying us a Late Payment Fee. Other fees and charges may also be assessed. If partial payments are made, they will be applied first to the oldest outstanding bill. If you send checks or money orders marked "payment in full," we can accept them without losing any of our rights to collect any other amounts owed by you, notwithstanding your characterization of the payment. DISH Network does not extend credit to our customers, and the Late Payment Fee is not interest, a credit service charge or a finance charge. You understand and agree that in the case of late payment or nonpayment for any Services ordered by you or for any of the charges stated below, we may report such late payment or nonpayment to credit reporting agencies. If you do not pay your bill by the due date, we have the right to disconnect your Services at any time thereafter, in our sole discretion. DISH Network may require you to pay all past due charges, a Reconnect Fee, a deposit equal to a minimum of one month's advance charges and all outstanding balances accrued through the date of deactivation, before we reconnect your Services. Deposits will not be held segregated from other funds and shall not earn or accrue interest.

C. If you at any time fail, neglect, or refuse to make timely payments hereunder, or if a petition in bankruptcy shall be filed on your behalf or against you, or if you take advantage of any insolvency law or become insolvent or make an assignment for the benefit of creditors, or if a receiver, liquidator, or trustee is appointed for your property or affairs, we shall be wholly relieved from our obligations hereunder.

D. If you paid for an annual or other multi-month subscription to any Services and your account is past due for any amounts owed to us, at our option we may suspend any or all Service until payment is received, and/or convert your annual or other multi-month subscription to a monthly subscription. If we convert your multi-month subscription to a monthly subscription, we will first apply the amount you paid for your multi-month subscription to any past due amounts and then any remaining amounts to future obligations. If we elect to offset the amount paid for the remaining portion of a multi-month subscription against amounts past due, you agree to pay, in addition to all other applicable fees, the Offset Fee set forth below for each month and partial month that the multi-month subscription was previously received.

E. If we use a collection agency or attorney to collect money you owe us or to assert any other right which we may have against you, you agree to pay the reasonable costs of collection or other action. These costs might include, but are not limited to, the costs of a collection agency, reasonable attorney's fees and court costs. If there are billing errors or other requests for credit, you can contact our Customer Service Center by telephone or in writing. You must contact us within sixty (60) days of the time you receive the billing statement for which you are seeking corrections. Failure to timely notify us of a dispute shall constitute acceptance of the bill. Undisputed portions of the billing statement must be paid before the next billing statement is issued to avoid an administrative fee for late payment. All payments for Services must be made directly by you to us. DISH Network shall have no obligation to provide Services for which payment is made by you to a third party.

F. In addition to the amounts due for Services, you agree to pay the fees referenced below ("Fees") when applicable. DISH Network reserves the right to increase these Fees or add additional Fees in the future, in our sole discretion

Smart Card Replacement Fee	\$50.00
Additional Receiver Authorization Fee (monthly, per receiver)	\$4.99
Late Payment Fee	\$5.00
Change of Service Fee	\$5.00
Duplicate Billing Statement Fee	\$2.00
Overnight Delivery Fee	\$18.00
Restart Fee	\$25.00
Returned Payment Fee	\$25.00
Service Access Fee (monthly)	\$5.00
Offset Fee	\$2.00
Ledger Request Fee	\$5.00
Pay-Per-View Automated Fee	\$1.00
Pay-Per-View Fee	\$5.00

3. CANCELLATION OF SERVICE

A. Your Service will continue until cancelled as provided for herein. Your subscription will be automatically renewed unless you contact us to cancel as provided for in the next paragraph.

B. You have the right to cancel your Service for any reason at any time by notifying us via telephone or in writing at the phone number or address set forth on page 1, above. Please be aware that certain promotional offers have a minimum subscription commitment (usually 12 months) and if you cancel your service prior to the expiration of that commitment, certain early termination fees may apply.

C. DISH Network has the right to terminate your Services at any time without providing notice to you if: (i) you fail to pay your bill when it is due; (ii) we receive confirmation that you have received the Services, or any part of the Services without paying for them; or (iii) you otherwise violate the terms of this Agreement.

D. If your Service is cancelled for any reason, you are still responsible for payment of all outstanding balances accrued, including any applicable Fees.

E. You understand that charges for Services, once charged to your account, are nonrefundable. For monthly subscriptions, the cancellation will be effective at the end of the period covered by the last monthly bill. No refunds or credits will be provided in connection with the cancellation of monthly subscriptions. For annual or other multi-month subscriptions, the cancellation will be effective as of the date the multi-month subscription expires. Because you are receiving a discounted price in exchange for your agreement to pay for your services on an annual or other multi-month basis, in the event you cancel the Services prior to expiration of your multi-month subscription, you understand and agree that you are not entitled to any refund or credit for the unused portions of the multi-month subscription and that we have the right to retain any prepaid monies as liquidated damages.

4. EQUIPMENT

A. In order to receive the Services it will be necessary for you to purchase or lease certain reception equipment consisting primarily of a DISH Network compatible satellite receiver, a satellite antenna, LNBF unit and remote control ("Equipment"). You may also be provided with a conditional access card ("Smart Card") that is inserted into your satellite receiver. The Smart Card remains the property of EchoStar Communications Corporation, the corporate parent of DISH Network and any tampering or other unauthorized modification to the Smart Card is strictly prohibited and may result in, and subject you to, legal action. You agree to return the Smart Card to us upon request.

B. Smart Cards are nontransferable. Your Smart Card will only work in the DISH Network receiver to which it was assigned by DISH Network. If you report to the Customer Service Center that your Smart Card was lost, damaged, defective or stolen we will replace it, as long as there is no evidence of unauthorized tampering or modification. A replacement fee will apply. In addition, in order to minimize downtime for your Equipment, DISH Network will, upon your request, deliver a replacement Smart Card to you via overnight delivery. Our Overnight Delivery Fee will apply.

C. DISH Network reserves the right to alter software in your DISH Network receiver, and provide content to PVR products, through periodic downloads. DISH Network will use commercially reasonable efforts to schedule these downloads in a manner that result in the least amount of interference with or interruption to your Service.

D. Your DISH Network receiver contains certain components and software which are proprietary to DISH Network. You agree that you will not try to reverse-engineer, decompile or disassemble any software or hardware contained within your receiver or our Smart Card. Such actions are strictly prohibited and may result in the termination of your Services and/or legal action.

E. For proper operation of your Equipment, DISH Network requires that you connect each DISH Network receiver on your account to a telephone line. For accounts containing multiple receivers, each receiver must be connected to the same telephone line.

F. If your DISH Network Equipment is stolen or otherwise removed from your premises without your authorization, you must notify our Customer Service Center immediately, but in any event not more than three (3) business days after such removal to avoid liability for payment for unauthorized use of the DISH Network Equipment. You will not be liable for unauthorized use after we have received your timely notification.

5. LEASED EQUIPMENT

A. If you decide to lease your Equipment from DISH Network, such Equipment shall at all times remain the sole and exclusive property of DISH Network and we will have the right, at our discretion, to replace it with new or reconditioned equipment and to remove the equipment upon termination of Services. None of the equipment shall be deemed fixtures or part of your realty. Our ownership of the equipment may be displayed by notice contained on the equipment. You shall have no right to pledge, sell, mortgage, give away or remove, relocate, alter or tamper with the equipment (or any notice of our ownership thereon) at any time. Any reinstallation, return of or change in location of the equipment shall be performed by us at the service rates in effect at the time of service. You shall not attach any electrical or other devices to or otherwise alter the equipment without our prior written consent. DISH Network shall have the right to make such filings as are necessary to evidence our ownership rights in the equipment, and you agree to execute any and all documents as are necessary for us to make such filings. Upon termination of Services, you must notify our Customer Service Center to schedule the return the Equipment.

B. You shall notify us promptly of any defect in, damage to, or accident involving the equipment. All maintenance and repair of the equipment shall be performed by us or our designees. DISH Network may charge you for any repairs that are necessitated by any damage to, or misuse of, the Equipment.

6. TRANSFER OF ACCOUNT, SERVICES OR EQUIPMENT

DISH Network may sell, assign or transfer your account to a third party without notice to you. You may not assign or transfer your Services without our written consent which will not be unreasonably withheld. We may, however, refuse to allow you to assign or transfer your Services if you lease your Equipment or if your account has an outstanding balance.

7. LIMITATION OF OUR LIABILITY

A. WE WILL NOT BE LIABLE FOR ANY INTERRUPTIONS IN SERVICE OR LIABLE FOR ANY DELAY OR FAILURE TO PERFORM, IF SUCH DELAY OR NONPERFORMANCE ARISES IN CONNECTION WITH THE TERMINATION OF ALL OR A PORTION OF THE SERVICES, THE RELOCATION OF ALL OR A PORTION OF THE SERVICES TO DIFFERENT SATELLITE(S), A CHANGE IN THE FEATURES AVAILABLE WITH YOUR DISH NETWORK DBS EQUIPMENT OR ANY ACTS OF GOD, FIRES, EARTHQUAKES, FLOODS, POWER OR TECHNICAL FAILURE, ACTS OF ANY GOVERNMENTAL BODY OR ANY OTHER CAUSE BEYOND OUR CONTROL. WE WILL NOT BE LIABLE FOR ANY DAMAGE RESULTING FROM LOSS OF RECORDED MATERIAL OR THE PREVENTION OF RECORDING DUE TO ANY FAULT, FAILURE, DEFICIENCY OR DEFECT IN SERVICES OR EQUIPMENT. WE MAKE NO WARRANTY, EITHER EXPRESSED OR IMPLIED, REGARDING THE DISH NETWORK DBS EQUIPMENT OR ANY SERVICES FURNISHED TO YOU. ALL SUCH WARRANTIES ARE EXPRESSLY EXCLUDED. IN NO EVENT SHALL WE HAVE ANY LIABILITY FOR SPECIAL, INDIRECT, INCIDENTAL OR CONSEQUENTIAL DAMAGES RELATING TO THE DBS EQUIPMENT OR RESULTING FROM OUR FURNISHING OR FAILURE TO FURNISH ANY SERVICES OR EQUIPMENT TO YOU, OR FROM ANY FAULT, FAILURE, DEFICIENCY OR DEFECT IN SERVICES OR EQUIPMENT FURNISHED TO YOU.

B. It is your responsibility to impose any restrictions on viewing by you, other members of your household, or guests, and we shall have no liability to anyone due to or based on the content of any of the Services furnished to you.

8. WARNING AGAINST PIRACY

It is a violation of several U.S. federal and state laws to receive any Services, or any portion of such Services, without paying for them. The penalties for violating such laws can range from imprisonment to civil damage awards of up to \$110,000 per violation.

9. MISCELLANEOUS

A. Physical Address/Change of Address. When setting up your DISH Network account, you agree to provide us with the physical street address where the Equipment will be located. A post office box does not constitute a physical address and is not sufficient to meet this requirement. You agree to give us prompt notice of your change of name, mailing address, physical address where the Equipment is located or telephone number. You may do this by notifying our Customer Service Center by telephone or in writing.

B. Notice. If we send you notice, it will be considered given when deposited in the U.S. Mail, addressed to you at your billing address or hand-delivered to you. Our notice to you will also be effective if provided on your billing statement or by telephone. If you give notice to us, it will be deemed given when received by us at the address listed on the first page of this Agreement.

C. Applicable Law. This Agreement, including all matters relating to its validity, construction, performance and enforcement, shall be governed by applicable federal law, the rules and regulations of the Federal Communications Commission, and the laws and regulations of the state and local area where Service is provided. These terms and conditions are subject to amendment, modification or termination if required by such regulations or laws. If any provision in this Agreement is declared to be illegal or in

conflict with any law or regulation, that provision may be deleted or modified, without affecting the validity of the other provisions.

D. Other. This document contains the entire agreement between DISH Network and you, the customer, and no salesperson, installer, customer service representative, authorized retailer, or other similarly situated individual is authorized to change the terms set forth herein. DISH Network may, however, change the terms and conditions of this Agreement in the future and will notify you if that occurs. The terms of this Agreement, which either are expressly stated to survive or by their nature would logically be expected to survive termination, shall continue thereafter until fully performed.

Staying Legal

Title 47, Section 605(e)4, United States Code (U.S.C.) makes it a federal crime to modify this receiver to enable it to receive encrypted (scrambled) television programming without payment of required subscriptions. Conviction can result in a fine of up to \$500,000 and imprisonment for five years, or both. Any owner of this receiver who procures or willfully causes its modification is an accessory to that offense and may be punishable in the same manner. Investigative authority for violations lies with the Federal Bureau of Investigation (FBI).

This product may incorporate copyright protection technology that is protected by U.S. patents and other intellectual property rights. Use of such copyright protection technology must be authorized by Macrovision, and is intended for home and other limited pay-per-view uses only unless otherwise authorized by Macrovision. Reverse engineering or disassembly is prohibited.

U.S. Patent No's 4631603, 4577216, 4819098 are licensed for limited pay per view only.

FCC Compliance



The following text is extracted from Federal Communications Commission (FCC) regulations, as of the publication date of this *Guide*. Contact the FCC (see following) or your library for the complete text of the regulations.

Telephone Communication

This equipment complies with Part 68 of the FCC rules and the requirements adopted by the ACTA. On the back panel of this equipment is a label that contains, among other information, a product identifier in the format US:AAAEQ##TXXXX. If requested, this number must be provided to the telephone company.

The REN is used to determine the number of devices that may be connected to a telephone line. Excessive RENs on a telephone line may result in the devices not ringing in response to an incoming call. In most but not all areas, the sum of RENs should not exceed five (5.0). To be certain of the number of devices that may be connected to a line, as determined by the total RENs, contact the local telephone company. For products approved after July 23, 2001, the REN for this product is part of the product identifier that has the format US:AAAEQ##TXXXX. The digits represented by ## are the REN without a decimal point (e.g., 03 is a REN of 0.3). For earlier products, the REN is separately shown on the label.

This equipment uses the following Universal Service Order Code (USOC) jacks: RJ-11C.

A plug and jack used to connect this equipment to the premises wiring and telephone network must comply with the applicable FCC Part 68 rules and requirements adopted by the ACTA. A compliant telephone cord and

modular plug is provided with this product. It is designed to be connected to a compatible modular jack that is also compliant. See installation instructions for details.

Connection to party line service is subject to state tariffs. Contact the state public utility commission, public service commission or corporation commission for information.

If your home has specially wired alarm equipment connected to the telephone line, ensure the installation of this equipment does not disable your alarm equipment. If you have questions about what will disable alarm equipment, consult your telephone company or a qualified installer.

If this equipment causes harm to the telephone network, the telephone company will notify you in advance that temporary discontinuance of service may be required. If advance notice is not practical, the telephone company will notify the customer as soon as possible. Also, you will be advised of your right to file a complaint with the FCC if you believe it is necessary.

The telephone company may make changes in its facilities, equipment, operations, or procedures that could affect the operation of the equipment. If this happens, the telephone company will provide advance notice in order for you to make the necessary modifications in order to maintain uninterrupted service.

If you experience trouble with this equipment, please contact Customer Service at 1-800-333-3474 for repair and warranty information. If the trouble is causing harm to the telephone network, the telephone company may request you remove the equipment from the network until the problem is resolved.



There are no customer repairable parts inside. Any attempts to repair the receiver will void your authorization to use it.

Radio Interference

This device complies with Part 15 of the FCC Rules. Operation is subject to the following two conditions:

1. this device may not cause harmful interference, and
2. this device must accept any interference received, including interference that may cause undesired operation.

Modifying this receiver may void your authority to use the equipment. This equipment has been tested and found to comply with the limits for a Class B digital device, pursuant to Part 15 of the FCC Rules. These limits are designed to provide reasonable protection against harmful interference in a residential installation. This equipment generates, uses and can radiate radio frequency energy and, if not installed and used in accordance with the instructions, may cause harmful interference to radio communications. However, there is no guarantee that interference will not occur in a particular installation. If this equipment does cause harmful interference to radio or television reception, which can be determined by turning the equipment off and on, the user is encouraged to try to correct the interference by one or more of the following measures:

- Reorient or relocate the receiving antenna.
- Increase the separation between the equipment and receiver.
- Connect the equipment into an outlet on a circuit different from that to which the receiver is connected.
- Consult the dealer or an experienced radio/TV technician for help.

Refer to *Troubleshooting* in *Chapter 5* for a detailed description of recommended customer actions. If none of the remedies on the previous page stops the radio interference, you should contact a licensed radio/television technician, your satellite dealer, or call the Customer Service Center at 1-800-333-3474, for assistance.

Index

A

- Audio
 - Changing Program Languages 46
- Automatic Event Timer 29

B

- Back Panel, Receiver 6
- Banner, Browse 22
- Banner, Program 22
- Blacked-Out Program 36
- Browse Banner 15
 - Changing Channels Using the Browse Banner 40
 - Displaying Information on Other Programs 22
 - Using the Browse Banner 22
- Buttons
 - Locking the Receiver Front Panel Control Buttons 40
 - Receiver Front Panel Control Buttons 5

C

- Caller ID 44
- Changing Channels 17
 - Changing Channels Using the Browse Banner 40
- Changing Program Languages 46
- Channel Locks 39
- Channels, Changing 17
- Closing the Menus 17
- Closing the Program Guide 21
- Coaxial Cable Connections 6
- Control Buttons, Receiver Front Panel 5
- Control, Remote 7
- Creating a VCR Event Timer 36
- Customer Service 71

D

- Displaying Program Information 22
 - Using the Browse Banner 22
 - Using the Program Banner 22

E

- Event Timers
 - Automatic Event Timer 29
 - Before an Event Timer Operates 30
 - Editing an Event Timer 33
 - Event Timer Frequencies 30
 - Event Timer Types 29
 - Locks, Blacked-Out Programs, and Event Timers 36
 - Manual Event Timer 29
 - Maximum Number of Event Timers 32
 - Power Off and Event Timers 36
 - Reviewing Event Timers 34
- Events (Programs) 29

F

- Favorite Lists
 - Changing the Name of a Favorite List 28
 - Creating or Modifying a Favorite List 27
 - Making a Favorite List Active 28
 - Using Favorite Lists 27
- Favorites Lists
 - How Resetting the Receiver Affects Favorites Lists 46
- FCC 93
- Federal Communications Commission (FCC) Compliance
 - Radio Interference 94
 - Telephone Communication 93
- Front Panel, Receiver 5

G

- Guide, Program 12, 20

H

- Highlighting a Choice in a Menu List 18
- Highlighting a Menu Option 18

I

- Information
 - Problems and Solutions Tables 71

L

- Legal Notices 93
- Lists of Choices in the Menus
 - Multiple Choice Lists 18
 - Single Choice Lists 18
- Locks
 - Accessing a Locked Item or Opening the Locks Menu 37, 43
 - Changing the Receiver Password 40, 43
 - Creating or Changing Channel Locks 39
 - Creating or Changing Rating (Content) Code Locks 38
 - Entering the Password 37
 - Hiding Adult Channels 42
 - How Resetting the Receiver Affects Locks 46
 - How to Set Locks - A Two Step Process 36
 - Locking Pay Per View Programs 41
 - Locking the Receiver 39
 - Locking the Receiver Front Panel Control Buttons 40
 - Opening the Locks Menu 37, 43
 - Personal Identification Number (PIN) 44
- Locks Menu (Parental and System Locks Menu) 13

M

- Main Menu 12
- Manual Event Timer 29
- Menu Options 17
 - Highlighting a Menu Option 18
 - Selecting a Menu Option 18
- Menus 11
 - Browse Banner 15, 22
 - Closing the Menus 17
 - Displaying Program Information 22
 - Highlighting a Choice in a Menu List 18
 - Lists of Choices in the Menus 18
 - Locks Menu (Parental and System Locks Menu) 13
 - Main Menu 12

- Menu Options 17
- Opening the Menus 17
- Parental and System Locks Menu (Locks Menu) 13
- Program Guide 12, 20
- Selecting a Choice in a Menu List 18
- Selecting a Menu Option 18
- System Setup Menu 13
- Theme Categories (Themes) Menu 12
- Time-Out Feature 17
- Using the Menus 17

O

- On-Screen Messages 72
- Opening the Menus 17
- Opening the Program Guide 21
- Options, Menu 17

P

- Parental and System Locks Menu (Locks Menu) 13
 - Opening the Menu When You Have Locked the Receiver 37
- Pay Per View
 - Stay Legal 93
- Pay Per View Programs
 - Locking Pay Per View Programs 41
- Personal Identification Number (PIN) 44
- PIN (Personal Identification Number) 44
- Power Light 5
- Problems and Solutions Tables 71
 - Using the Remote Control 75
- Program Banner
 - Using the Program Banner 22
- Program Guide 12
 - Closing the Program Guide 21
 - Opening the Program Guide 21
 - Selecting a Program in the Program Guide 21
 - Using the Program Guide 20
- Programs
 - Events 29

R

- Radio Interference 94
- Rain and Snow Fade 3
- Rating (Content) Code Locks 38
- Receiver
 - Back Panel 6
 - Changing the Password 43
 - Front Panel 5
 - Locking the Receiver 39
 - Menus 11
 - Radio Interference 94
 - Resetting the Receiver 46
 - Telephone Communication 93
- Receiver Back Panel 6
- Receiver Front Panel 5
 - Control Buttons 5
 - Locking the Front Panel Control Buttons 40
 - Power Light 5
- Remote Control 7
 - Using the Remote Control 75
- REN 93
- Resetting the Receiver 46
- Ringer Equivalence Number (REN) 93

S

- Satellite Signal Quality 3
 - Rain and Snow Fade 3
 - Solar Interference 4
- Selecting a Choice in a Menu List 18
- Selecting a Menu Option 18
- Selecting a Program in the Program Guide 21
- Service, Customer 71
- Setting and Using Security Locks
 - Locks, Blacked-Out Programs, and Event Timers 36
- Setting Up the Receiver and VCR to Use a VCR Event Time 36
- Signal Quality, Satellite 3
- Solar Interference 4
- Staying Legal 93
- System Setup Menu 13

T

- Telephone Connection
 - Testing the Telephone Connection 47
- Testing the System
 - Starting a Test 47
 - Telephone Connection 47
- Theme Categories (Themes)
 - Using Themes 25
- Theme Categories (Themes) Menu 12
- Themes (Theme Categories)
 - Using Themes 25
- Timers, Event
 - Locks, Blacked-Out Programs, and Event Timers 36
 - Power Off and Event Timers 36
- Troubleshooting
 - Problems and Solutions Tables 71
- Troubleshooting Tables
 - Buying a Pay Per View Program 79
 - Changing Channels 78
 - On-Screen Messages 72
 - Using Event Timers 80
 - Using Favorite Lists 78
 - Using Locks 77
 - Using the Menus 77
 - Using the Program Guide or the Browse Banner 77
 - Using the Telephone for Voice/Data/FAX 79

U

- Using Caller ID 44
- Using Favorite Lists 27
- Using the Menus 17
 - Closing the Menus 17
 - Displaying Program Information 22
 - Highlighting a Choice in a Menu List 18
 - Highlighting a Menu Option 18
 - Lists of Choices in the Menus 18
 - Menu Options 17
 - Opening the Menus 17
 - Selecting a Choice in a Menu List 18
 - Selecting a Menu Option 18
- Using the Program Guide 20
- Using the Remote Control 75

Notes

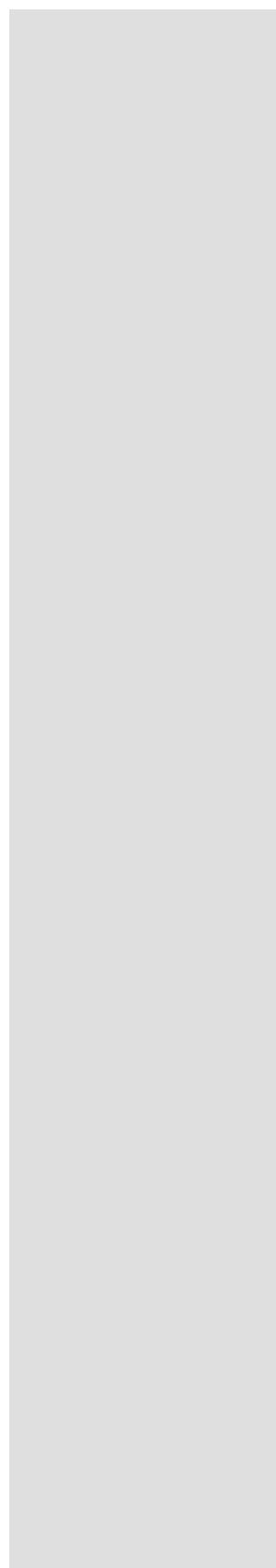

Notes

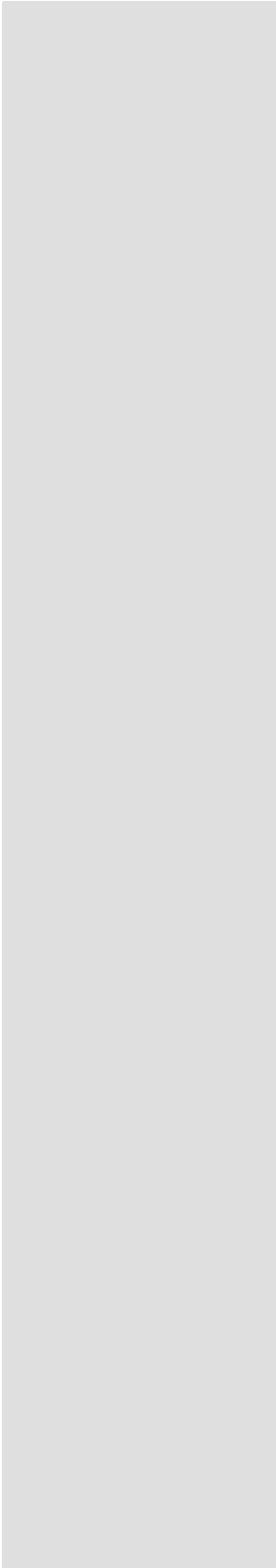

Write the following information in the spaces provided below. You may need to provide this information if you call the Service Center. To get the Conditional Access Numbers, display the **Important System Information** menu (see *Ordering Your Program Packages* on page 2).

Purchase Location Name:	
Purchase Location Telephone Number:	
Receiver Serial Number:	
Receiver Conditional Access Number	
Smart Card Conditional Access Number:	