



SGI® Modular InfiniteStorage™ (MIS) Platform User Guide

007-5818-003

COPYRIGHT

© 2012 Silicon Graphics International Corp. All rights reserved; provided portions may be copyright in third parties, as indicated elsewhere herein. No permission is granted to copy, distribute, or create derivative works from the contents of this electronic documentation in any manner, in whole or in part, without the prior written permission of SGI.

LIMITED RIGHTS LEGEND

The software described in this document is “commercial computer software” provided with restricted rights (except as to included open/free source) as specified in the FAR 52.227-19 and/or the DFAR 227.7202, or successive sections. Use beyond license provisions is a violation of worldwide intellectual property laws, treaties and conventions. This document is provided with limited rights as defined in 52.227-14.

The electronic (software) version of this document was developed at private expense; if acquired under an agreement with the USA government or any contractor thereto, it is acquired as “commercial computer software” subject to the provisions of its applicable license agreement, as specified in (a) 48 CFR 12.212 of the FAR; or, if acquired for Department of Defense units, (b) 48 CFR 227-7202 of the DoD FAR Supplement; or sections succeeding thereto. Contractor/manufacturer is SGI, 46600 Landing Parkway, Fremont, CA 94538.

TRADEMARKS AND ATTRIBUTIONS

Silicon Graphics, SGI, the SGI logo, InfiniteStorage, and Supportfolio are trademarks or registered trademarks of Silicon Graphics International Corp. or its subsidiaries in the United States and/or other countries worldwide.

Fusion-MPT, Integrated RAID, MegaRAID, and LSI Logic are trademarks or registered trademarks of LSI Logic Corporation. InfiniBand is a registered trademark of the InfiniBand Trade Association. Intel and Xeon are trademarks or registered trademarks of Intel Corporation or its subsidiaries in the United States and other countries. Internet Explorer and Windows are registered trademarks of Microsoft Corporation. Java and Java Virtual Machine are trademarks or registered trademarks of Sun Microsystems, Inc. Linux is a registered trademark of Linus Torvalds, used with permission by SGI. Novell and Novell Netware are registered trademarks of Novell Inc. PCIe and PCI-X are registered trademarks of PCI SIG. Red Hat and all Red Hat-based trademarks are trademarks or registered trademarks of Red Hat, Inc. in the United States and other countries. Sharp is a registered trademark of Sharp corporation. SUSE LINUX and the SUSE logo are registered trademarks of Novell, Inc. VMware is a registered trademark or trademark of VMware, Inc. in the United States and/or other jurisdictions.

All other trademarks mentioned herein are the property of their respective owners.

Record of Revision

Version	Description
001	June 2012 Original printing.
002	August 2012 Edited and updated for technical and editorial changes. Images updated to reflect changes, added Zones and CLI Zoning Tool software information, available RAID configurations updated.
003	October 2012 Electromagnetic Compatibility (EMC) compliance and safety information included. Section on CPU/Riser/HBA configuration restrictions and options added. Weight safety maximums included. Additional information on RAID options and conditions provided. Includes updates from the stand-alone version of Chapter 3 issued in September 2012. Information on grouping control added per customer feedback (Appendix C).

:

Contents

Introduction	. xix
Audience	. xix
Important Information	. xix
Safety Precautions	. xix
ESD Precautions	. xxi
Safety & Emissions	. xxi
Electromagnetic Compatibility	. xxii
Safety Certification	. xxii
Chapter Descriptions	. xxiii
Related Publications	. xxiv
Conventions	. xxv
Product Support	. xxv
CRU/FRU	. xxv
Purchasable Support & Maintenance Programs	. xxvi
Reader Comments	. xxvi
1 System Overview	1
MIS Enclosure	5
Front Grille and Control Panels	6
Rear Panel Components	7
MIS Common Modules	10
Power Supply Module	10
Fan Assembly Module	11
StorBrick Module	12
MIS Server Platform or JBOD Unit	14
Server Module	14
Layout of Server CPUs, and PCIe Risers HBAs	20
Boot Drives Module	21

	MIS JBOD I/O Module 22
	System Block Diagram 23
2	System Interfaces 25
	Control Panel 25
	MIS Server Control Panel 25
	MIS JBOD Control Panel 27
	Disk Drive LEDs 28
	Power Supply LEDs 28
	BMC Integrated Web Console 29
	System Information 30
	FRU Information 31
	System Debug Log 32
	CPU Information 34
	DIMM Information 34
	Server Health 35
	Sensor Readings 35
	Event Log 36
	Power Statistics 37
	Configuration Tab 38
	IPv4 Network 39
	IPv6 Network 40
	Users 42
	Login 43
	LDAP 45
	VLAN 46
	SSL 48
	Remote Session 48
	Mouse Mode 50
	Keyboard Macros 52
	Alerts 54
	Alert Email 55
	Node Manager 56
	Remote Control Tab 59

	Console Redirection	59
	Server Power Control	61
3	System Software	65
	Overview	65
	Section Guide	66
	Linux Zoning Tools	68
	Installing Linux Software	68
	MegaRAID Storage Manager for Linux	68
	MegaCli64 for Linux	69
	Zones for Linux	69
	CLI Zoning Tool for Linux	70
	Verify Drives Seen.	71
	Linux Zones Tool	71
	Installing a Drive through Zones for Linux	74
	Creating the Drive Groups in MegaRAID for Linux	77
	Formatting the Drives using YaST2 in Linux	79
	Removing a Drive in Zones for Linux.	83
	Additional Features in Zones for Linux	85
	Loading .csv Configuration Files in Linux	86
	Save a Configuration to .csv file in Linux	86
	Windows Zoning Tools	88
	Installing Windows Software	88
	MegaRAID Storage Manager for Windows	88
	MegaCli64 for Windows	89
	Zones for Windows	89
	Python for Windows	91
	CLI Zoning Tool for Windows	91
	Verify Drives Seen in Windows	92
	Zones for Windows.	92
	Installing a Drive in Zones for Windows	95
	Creating the Drive Groups in MegaRAID for Windows	98
	Formatting the Drives in Windows Server Manager	100
	Removing a Drive in Zones for Windows.	106

Additional Features in Zones for Windows	107
Loading .csv Configuration Files in Zones for Windows	107
Adapter Assignment Synchronization in Zones for Windows	108
Save a Configuration to .csv file in Zones for Windows	109
CLI Zoning Tool	109
Preparing to Zone using the CLI Zoning Tool	110
Editing the ShackCLI.ini file for Linux	111
Editing the ShackCLI.ini file for Windows	112
CLI Zoning Tool Main Menu	113
Zoning Using CLI Zoning Tool	117
Editing the .csv File for the CLI Zoning Tool	119
Disk RAID Support	122
RAID 0	123
RAID 1	124
RAID 5	125
RAID 6	125
RAID 00	126
RAID 10	127
RAID 50	128
RAID 60	128
RAID Configuration Notes	129
4 System Maintenance	133
Detecting Component Failures	134
Sliding the Chassis Forward/Backwards	134
Removing the Front or Rear Chassis Cover	134
Replacing a Power Supply	135
Replacing a Fan Module	136
Replacing a Disk Drive	137
Removing the Drive	138
Re-installing the Drive	139
Checking the System Air Flow	140

5	Troubleshooting	.141
	No Video	.141
	Losing the System's Setup Configuration	.141
	I/O Time-outs and MegaRAID Drivers	.142
	Safe Power-Off	.142
A	Technical Specifications	.143
B	BIOS Error Codes	.147
C	Zone Permission Groups Rules	.149

Figures

Figure 1-1	SGI Destination Rack (D-Rack)	4
Figure 1-2	MIS Chassis and Case	5
Figure 1-3	Bi-directional rail mount	6
Figure 1-4	Single Control Panel	7
Figure 1-5	Dual Control Panel	7
Figure 1-6	Rear View – MIS Server Platform (single server)	8
Figure 1-7	Rear View – MIS Server Platform (single server, four power supplies).	8
Figure 1-8	Rear View – MIS Server Platform (dual server).	8
Figure 1-9	Rear View – MIS Server Platform (single dual-server module).	9
Figure 1-10	Rear View – MIS JBOD Unit (single I/O module)	9
Figure 1-11	Rear View – MIS JBOD unit (dual I/O modules)	9
Figure 1-12	Power Supply Module (rated at 1100 Watts)	11
Figure 1-13	Power Supply Numbering	11
Figure 1-14	Fan Assembly Module (each contains two impellers)	11
Figure 1-15	StorBrick Modules for 3.5" or 2.5" 15mm Drives (left) and 2.5" 9.5 mm Drives (right)	12
Figure 1-16	3.5" 15mm Drive and Carrier	13
Figure 1-17	3.5" 15mm Drive Carrier (top view, with thumb latch)	13
Figure 1-18	Two 2.5" 9.5mm Drives and Carrier	13
Figure 1-19	2.5" 9.5mm Drive Carrier (isometric view with dual thumb latches)	14
Figure 1-20	MIS Server Platform (single server)	15
Figure 1-21	MIS Server Platform (dual server)	16
Figure 1-22	MIS JBOD Unit	17
Figure 1-23	MIS Server Module – single server	18
Figure 1-24	Server Module (single server) – component view	18
Figure 1-25	MIS Server Module – dual server (half height)	19
Figure 1-26	Dual Server Module – component view	19
Figure 1-27	CPU and PCIe Riser layout	20

Figure 1-28	HBA population layout 21
Figure 1-29	Boot Drive Module 22
Figure 1-30	I/O Module for MIS JBOD Unit 22
Figure 1-31	MIS JBOD Midplane I/O Connector (right & left views) 23
Figure 1-32	System-Level Block Diagram. 24
Figure 2-1	MIS Control Panel 26
Figure 2-2	Disk Drive LEDs 28
Figure 2-3	Power Supply LEDs 28
Figure 2-4	BMC Web Console – System Information Page 31
Figure 2-5	BMC Web Console – FRU Information 32
Figure 2-6	BMC Web Console – System Debug Log 33
Figure 2-7	BMC Web Console – CPU Information 34
Figure 2-8	BMC Web Console – DIMM Information 35
Figure 2-9	BMC Web Console – Server Health 36
Figure 2-10	BMC Web Console – Event Log 37
Figure 2-11	BMC Web Console – Power Statistics 38
Figure 2-12	BMC Web Console – IPv4 Network Settings 40
Figure 2-13	BMC Web Console – IPv6 Network Settings 42
Figure 2-14	BMC Web Console – Login Security Settings 44
Figure 2-15	BMC Web Console – LDAP Settings. 46
Figure 2-16	BMC Web Console – VLAN Settings 47
Figure 2-17	BMC Web Console – SSL Upload 48
Figure 2-18	BMC Web Console – Remote Session 50
Figure 2-19	BMC Web Console – Mouse Mode Setting 51
Figure 2-20	BMC Web Console – Logout, Refresh, and Help buttons 52
Figure 2-21	BMC Web Console – Keyboard Macros 52
Figure 2-22	BMC Web Console – Alerts 55
Figure 2-23	BMC Web Console – Alert Email Settings 56
Figure 2-24	BMC Web Console – Node Manager Power Policies 57
Figure 2-25	BMC Web Console – Console Redirection (greyed-out). 60
Figure 2-26	BMC Web Console – Launch Console button (available) 60
Figure 2-27	Remote Console – Java redirection window 61

Figure 2-28	BMC Web Console – Power Control and Status.	62
Figure 3-1	Zones – First-use path configuration.	70
Figure 3-2	Zones – Error message: Improper path	70
Figure 3-3	Linux Zones Welcome	71
Figure 3-4	Zones User Interface	72
Figure 3-5	Zones – Show All, Open Session, Save Session, Download Session, and Exit buttons	72
Figure 3-6	Zones – Opening a Session	73
Figure 3-7	Zones – Enter Session Alias	73
Figure 3-8	Zones – Alias Help Warning Message	74
Figure 3-9	Zones – Adapter tabs	74
Figure 3-10	Zones – Show All	75
Figure 3-11	Zones – Adapter Assignment Warning Message	75
Figure 3-12	Zones – Select StorBricks for download.	76
Figure 3-13	MegaRAID – Create a Virtual Drive.	77
Figure 3-14	MegaRAID – Create Virtual Drive mode	77
Figure 3-15	Create Virtual Drive – Drive Group Settings	78
Figure 3-16	Create Virtual Drive – Summary.	78
Figure 3-17	Yast2 Server Manager GUI	79
Figure 3-18	YaST2 – Warning Message	80
Figure 3-19	YaST2 – Drives have appeared	80
Figure 3-20	YaST2 – Add button	81
Figure 3-21	YaST2 – Select Partition Size	81
Figure 3-22	YaST2 – Format & Mount the Drive.	81
Figure 3-23	YaST2 – Check for Partition	82
Figure 3-24	YaST – Click Finish	82
Figure 3-25	YaST2 – Disk Mounting (in process)	83
Figure 3-26	Zones – Downloading setting to StorBrick(s)	84
Figure 3-27	Zones – Are you sure to download files to expander?	85
Figure 3-28	Zones – Select CSV File (Linux)	86
Figure 3-29	Zones – Save Configuration to .csv	86
Figure 3-30	Zones – Save CSV pop-up	87
Figure 3-31	Zones – Select Directory navigation pane	87

Figure 3-32	Zones – Error: Improper Directory Selection 88
Figure 3-33	Zones – First-use path configuration (Windows) 90
Figure 3-34	Zones – Error messages from improper path configuration 91
Figure 3-35	Windows Server Manager – Disk Management 92
Figure 3-36	Zones for Windows Welcome 93
Figure 3-37	Zones Windows User Interface 93
Figure 3-38	Zones – Open Session, Save Session, Download Session, and Exit buttons .	93
Figure 3-39	Zones – Open Session. 94
Figure 3-40	Zones – Enter Session Alias 94
Figure 3-41	Zones – Alias Help Warning Message 95
Figure 3-42	Zones – Adapter tabs (Windows) 95
Figure 3-43	Zones – Show All 96
Figure 3-44	Zones – Adapter Assignment Warning Message 96
Figure 3-45	Zones – Select StorBricks for download 97
Figure 3-46	Zones tool – Verify download 98
Figure 3-47	MegaRAID – Create a Virtual Drive 98
Figure 3-48	MegaRAID – Create Virtual Drive mode. 99
Figure 3-49	Create Virtual Drive – Simple Settings 99
Figure 3-50	Create Virtual Drive – Summary	100
Figure 3-51	Server Manager – Disk Management	101
Figure 3-52	Server Manager – Initialize Disks	101
Figure 3-53	Server Manager – Select GPT (GUID Partition Table)	102
Figure 3-54	Server Manager – Disks Initialized and Online	102
Figure 3-55	Server Manager – New Simple Volume	103
Figure 3-56	Server Manager – New Simple Volume Wizard	103
Figure 3-57	New Simple Volume Wizard – Volume Size.	104
Figure 3-58	New Simple Volume Wizard – Assign Drive Letter or Path	104
Figure 3-59	New Simple Volume Wizard – Format Partition	105
Figure 3-60	New Simple Volume Wizard – Settings Confirmation	105
Figure 3-61	New Simple Volume in Server Manager	106
Figure 3-62	Zones – Verify Download.	106
Figure 3-63	Zones – Select CSV File	107
Figure 3-64	Zones – Error message: Canceling csv file selection (Windows) . . .	108

Figure 3-65	Zones – Select All, Unselect All buttons.108
Figure 3-66	MIS-S9D proprietary network interface111
Figure 3-67	Block diagram of MIS-Server StorBrick SB0121
Figure 3-68	RAID 0123
Figure 3-69	RAID 1124
Figure 3-70	RAID 5125
Figure 3-71	RAID 6125
Figure 3-72	RAID 00126
Figure 3-73	RAID 10127
Figure 3-74	RAID 50128
Figure 3-75	RAID 60128
Figure 3-76	RAID 1 with one drive per StorBrick129
Figure 3-77	RAID 1 with two drives spanning a StorBrick130
Figure 3-78	RAID 5 or 6 with one drive per StorBrick131
Figure 3-79	Loss of a drive with multiple drives on a StorBrick does not affect RAID 6, but will impact RAID 5131
Figure 3-80	Three drive loss in RAID 6 require StorBrick replacement131
Figure 4-1	Front & Rear Chassis Covers135
Figure 4-2	Replacing a Power Supply136
Figure 4-3	Replacing a Fan Module137
Figure 4-4	Hard Drive Carrier139
Figure 4-5	MIS Chassis Midspan Support Brace140
Figure C-1	Zone Permission Groups – Example 1150
Figure C-2	Zone Permission Groups – Example 2151

Tables

Table -1	MIS Server Platform Region and EMC Compliance Referencesxxii
Table -2	MIS Server Platform Region and EMC Compliance References . . .	xxiii
Table 2-1	MIS Server Platform Control Panel Buttons and LEDs	26
Table 2-2	Disk Drive LEDs	28
Table 2-3	Power Supply LEDs	29
Table 2-4	System Information Details	30
Table 2-5	Supported Key Names	53
Table 2-6	Server Power Control Actions	61
Table 2-7	System Information Details	63
Table 3-1	Zone Group Implementation110
Table 3-2	CLI Zoning Tool Menu Options and Descriptions114
Table 3-3	Zone Group Implementation120
Table A-1	Technical Specifications143
Table B-1	BMC Beep Codes147

Introduction

This guide describes the features and components of the SGI® Modular InfiniteStorage™ (MIS) platform. With two main configurations possible for the enclosure (server and storage, or JBOD—Just Bunch Of Disks) this guide covers the different configurations, their respective components, interface panels, indicator lights and meanings, software, maintenance, and troubleshooting.

Audience

This guide is written for owners/users of the MIS platform. It is written with the assumption that the reader has a good working knowledge of computers, servers, networking, hardware, software and RAID arrays.

Important Information

The following section details several safety precautions that should be observed at all times. First, a fully loaded MIS Platform can weigh up to 220lbs. Second, electricity is a major concern, especially Electrostatic Discharge (ESD), detailed later in this section. Please read these sections carefully prior to using the MIS Platform.

Safety Precautions

Do NOT wear loose clothing, such as neckties or unbuttoned shirt sleeves, while working on the unit which can be pulled into a cooling fan or tangled in cabling.

Remove any jewelry any metal objects from your body, which are excellent electrical conductors, and can harm you and/or cause short circuits if they come into contact with printed circuit boards or powered areas.

Be aware of the locations of the power on/off switch on the chassis as well as the room's emergency power-off switch, disconnection switch or electrical outlet. If an electrical accident occurs, you can then quickly remove power from the system.

Do NOT work alone when working with high voltage components.

When working around exposed electrical circuits, another person should be nearby, who is familiar with the power-off controls, to switch off the power if necessary.

Use only one hand when working with powered-on electrical equipment. This is to avoid making a complete circuit, which will cause electrical shock. Use extreme caution when using metal tools, which can easily damage any electrical components or circuit boards with which they come into contact.

Do NOT use mats designed to decrease static electrical discharge as protection from electrical shock. Instead, use rubber mats that have been specifically designed as **electrical insulators**.

The power supply power cords must include a grounding plug and must be plugged into grounded electrical outlets.

Do NOT attempt to transport/move a fully loaded MIS system. An MIS system can weigh up to 220lbs. when fully loaded. If the system must be moved, first remove the drives from the chassis. When lifting the system, two people (one at each end) should lift slowly with feet spread apart to distribute the weight. Always follow safe lifting practices when moving heavy objects. More information on moving large objects, requiring a two-person team, is available in the Centers for Disease Control's, "Ergonomic Guidelines for Manual Material Handling" (<http://www.cdc.gov/niosh/docs/2007-131/pdfs/2007-131.pdf>)

Power should always be disconnected from the system when removing or installing system components that are not hot-swappable, such as server boards and memory modules. When disconnecting power, you should first do a clean shut down of the operating system, then power down the system, and then unplug all power cords (the unit has more than one power supply cord). More information on powering off the MIS Platform is available in Chapter 4, "System Maintenance."

ESD Precautions



Caution: Electrostatic Discharge (ESD) is generated by two objects with different electrical charges coming into contact with each other. An electrical discharge is created to neutralize this difference, which can damage electronic components and printed circuit boards.

The following measures are generally sufficient to neutralize this difference before contact is made to protect your equipment from ESD:

- Use a grounded wrist strap designed to prevent static discharge.
- Keep all components and printed circuit boards (PCBs) in their antistatic bags until ready for use.
- Touch a grounded metal object before removing the board from the antistatic bag.
- Do not let components or PCBs come into contact with your clothing, which may retain a charge even if you are wearing a wrist strap.
- Handle a board by its edges only; do not touch its components, peripheral chips, memory modules or contacts.
- When handling chips or modules, avoid touching their pins.
- Put the server board and peripherals back into their antistatic bags when not in use.
- For grounding purposes, make sure your computer chassis provides excellent conductivity between the power supply, the case, the mounting fasteners and the server board.

Safety & Emissions

The following is a list of agency approvals for MIS on safety and emissions.

Electromagnetic Compatibility

Table -1 lists the region and compliance reference for EMC (Electromagnetic Compatibility) compliance.

Table -1 MIS Server Platform Region and EMC Compliance References

Region	Compliance Reference
Australia/ New Zealand	AS/NZS 3548 (Emissions)
Canada/USA	CSA 60950 / UL60950/ 60950-1 cert to CAN/CSA STD C22.2 No. 60950-1 Industry Canada ICES-003 FCC CFR47, Part 15
CENELEC Europe	EN55022 Emissions EN55024 Immunity
International	CISPR 22/ CISPR 24
Japan	VCCI Certification
Korea	KCC Certification
Taiwan	BSMI CNS 13438
China	CCC
Russia	GOST

Safety Certification

Underwriters Laboratories (UL) provides safety certification for electronic devices. UL offers a Functional Safety Listing Mark that can be added for those qualifying companies in the process of getting a traditional Listing from UL. In essence, the Functional Safety Listing Mark replaces the traditional UL listing mark on products certified for functional safety. Functional safety examines the efficacy of the safety-related system by considering the input variables to a device and confirming that the activating quantities of the output are within its designed parameters/ratings. So it goes beyond the traditional fire and electric shock safety associated with

the traditional UL Listing Mark. Table -2 lists the region and compliance reference for EMC (Electromagnetic Compatibility) compliance.

Table -2 MIS Server Platform Region and EMC Compliance References

Region	Compliance Reference
Canada/USA	CSA 60950 / UL60950/ Compliance Document UL report 60950-1 cert to CAN/CSA STD C22.2 No. 60950-1
IEC (Europe)	IEC60950-1 – CB Certification, CE Mark Compliance Document UL report
Russia	GOST

Chapter Descriptions

Chapter 1, “System Overview,” describes the hardware components of the MIS enclosures, the common modules in unit, and the major differences between the MIS Server Platform and MIS JBOD Unit. Additional information includes the operating systems supported, and RAID configurations possible with the MIS enclosures.

Chapter 2, “System Interfaces,” describes the hardware and software interfaces used to operate the MIS Server and MIS JBOD. This includes the front control panel, disk drive LEDs, power supply LEDs, and the BMC Web Console.

Chapter 3, “System Software,” covers the software used on the MIS Platforms, including installation information for the tools, using the MegaRAID tool, and the available zoning software (Zones and CLI Zoning Tool). Depending on the operating system, there are certain prerequisite programs and this chapter gives instructions for download and installation of these programs. In this chapter are step-by-step instructions for Zones tool, its features and their function, plus warnings and error codes. Screen shots are given for a walk-through of the tool. Detailed in this chapter next are step-by-step instructions for zoning using the CLI Zoning tool (the only tool that can zone JBODs at this time).

Chapter 4, “System Maintenance,” describes how to use Sensor Data Records for detecting component failures, and service instructions for modules that are customer replaceable units (CRUs). The service instructions include how to move the chassis forward or backwards in the rack, how to remove the case front and read covers, how to remove the midspan support bar for ease of access to cabling, how to replace a power supply, how to replace a storage drive in a

StorBrick, how to replace a boot drive, how to replace a fan module, and additional air-flow precautions.

Chapter 5, “Troubleshooting,” describes some problem-solving techniques, plus when and how to contact customer support.

Appendix A, “Technical Specifications,” gives the technical specifications for the MIS enclosures.

Appendix B, “BIOS Error Codes,” details the beep codes used when a problem is detected by the BMC environmental controls.

Related Publications

The following documents are relevant to the MIS Platform:

- *MegaRAID SAS Software User Guide*, publication number 51530-00, Rev E.
- *MegaRAID 6Gb/s SAS RAID Controllers User Guide*, publication number 41450-02, Rev E.
- *Intel Server Boards and Server Platforms Server Management Guide*, publication number 37830-002
- *SGI Foundation Software*, publication number 007-5641-00x
- *SGI Performance Suite*, publication number 007-5680-00x
- SGI InfiniteStorage series documentation (<http://techpubs.sgi.com>)
- Man pages (<http://www.linuxmanpages.com/>)

Various formats of SGI documentation, release notes, and man pages are available. The SGI Technical Publications Library (<http://docs.sgi.com/>) contains the most recent and most comprehensive set of online books, release notes, man pages, and other information. Refer to the SGI Supportfolio™ web page for documents which access requires a support contract (as do the MegaRAID books cited above). See “Product Support” on page xxv. You can also view man pages by typing `man <title>` on a command line in Linux.

Conventions

The following conventions are used throughout this document:

Convention	Meaning
Command	This fixed-space font denotes literal items such as commands, files, routines, path names, signals, messages, and programming language structures.
<i>variable</i>	The italic typeface denotes variable entries and words or concepts being defined. Italic typeface is also used for book titles.
[]	Brackets enclose optional portions of a command or directive line.
GUI element	This font denotes the names of graphical user interface (GUI) elements such as windows, screens, dialog boxes, menus, toolbars, icons, buttons, boxes, fields, and lists.

Product Support

SGI provides a comprehensive product support and maintenance program for its products, as follows:

- If you are in North America, contact the Technical Assistance Center at +1 800 800 4SGI (4744) or contact your authorized service provider.
- If you are outside North America, contact the SGI subsidiary or authorized distributor in your country. International customers can visit <http://www.sgi.com/support/> Click on the “Support Centers” link under the “Online Support” heading for information on how to contact your nearest SGI customer support center.

CRU/FRU

Some of the components on the MIS Platform are customer-replaceable units (CRUs), meaning that these modules were designed to be repaired/replaced by you, the customer. These include fan assemblies, power supplies, storage drives, and boot drives, all of which are hot-swappable. However, many of the other components on the MIS Platform should be serviced by SGI field technicians **ONLY**, so as not to violate the warranty agreement. The components are field-technician replaceable units, or FRUs. It is important to note that our CRUs can be easily installed and replaced by customers, which enables a speedy recovery of proper system operation.

For additional information about CRUs, please see:

- [Customer Replaceable Units \(CRUs\) Installation Policy](#)
- [Customer Replaceable Units \(CRU\) and Customer Obligations](#)

Purchasable Support & Maintenance Programs

SGI provides several comprehensive product support and maintenance programs for its products. SGI also offers services to implement and integrate Linux applications in your environment.

- Refer to <http://www.sgi.com/services/>
- If you are in North America, contact the Technical Assistance Center at +1-800-800-4SGI (4744), or contact your authorized service provider.
- If you are outside North America, contact the SGI subsidiary or authorized distributor in your country. See <http://www.sgi.com/global/index.html> for more information.

Reader Comments

If you have comments about the technical accuracy, content, or organization of this document, please contact SGI. Be sure to include the title and document number of the manual with your comments. (Online, the document number is located in the front matter of the manual. In printed manuals, the document number is located at the bottom of each page.)

You can contact SGI in any of the following ways:

- Send e-mail to the following address: techpubs@sgi.com
- Contact your customer service representative, and ask that an incident be filed in the SGI incident tracking system.
- Send mail to the following address:

SGI
Technical Publications
46600 Landing Parkway
Fremont, CA 94538

SGI values your comments, and will respond to them promptly.

System Overview

The SGI Modular InfiniteStorage Platform is a high-density, integrated storage server platform. The MIS Platform uses a 4U rackmount system, and can be either a compute and storage server, or a “Just Bunch Of Disks” expansion storage unit (MIS JBOD unit). The MIS Server Platform can be single or dual server. Up to 5 MIS enclosures (server & JBODs) or 6 JBODs can be mounted into a SGI Destination rack (D-Rack), as shown in Figure 1-1. (Other 3rd-party 19" racks are also supported.) A D-Rack has space for up to 10 enclosures, however, due to floor weight regulations, only 5-6 units may be installed in a single D-Rack. See

Features of the modular design of the MIS Platform include:

- Up to 72 (3.5" or 2.5" 15mm) and a maximum of 144 (2.5" 9.5mm) storage drives in the Server Platform
- Up to 81 (3.5" or 2.5" 15mm) and a maximum of 162 (2.5" 9.5mm) storage drives in the JBOD unit
- All fit in a standard size 4U chassis: height 6.94" (176mm), width 16.9" (429.2mm), depth 36" (914.4mm).

Storage drives can be 3.5" or 2.5" (15mm or 9.5mm), SAS or SATA, rotational or SSD drives. Up to four JBOD units can be attached to one MIS Dual Server Platform.



Warning: Rotational SAS drives and rotational SATA drives cannot be included in the same enclosure due to vibration conflicts.

The MIS Server Platform features:

- Up to 2 server modules per platform.
 - One or two Intel® Xeon® E5-2600 series processors per server motherboard.

- Intel Turbo Boost Technology 2.0 that automatically allows processor cores to run faster than the base operating frequency, if the cores are operating below power, current, and temperature specification limits (< 35°C ambient).
- Up to 8 DDR3 DIMMs (4 GB, 8 GB, or 16 GB) for a single-server motherboard configuration, and up to 16 DIMMs for a dual-server motherboard configuration.
- Up to 4 HBAs for a single server, full-height (4.25") and half-depth (3.375"), externally or internally facing. Up to 4 HBAs (half-height, half-depth; 2 per server module) for a dual server. There are an additional two internally facing, half-height and half-depth HBAs per server module, used by the system. The MIS Single Server Platform can have a total of six HBAs, where a Dual Server Platform can have a maximum of eight (including those used by the system).
- Up to 3 PCIe riser cards for single server systems (dual-servers have a mandatory 3 PCIe risers, regardless of card count).
- Up to four battery back up units for a single server module. Up to three battery back up units per server module for a dual server platform, for a total maximum of six. (Unique BBU PCIe technology allows the inclusion of BBUs without the consumption of any of the available PCIe slots.)
- Two boot drives per server: SAS or SATA, rotational or SSD, up to 300GB, mirrored using RAID 1.
- Dual GbE networking onboard, with an optional 2 port 10GbE, 2 port GbE, or 4 port 8Gb FC PCIe cards (4 optional networking PCIe cards maximum, external facing only; risers 1 and 2).



Warning: Floor loading has a maximum weight allowance of 250lbs per square foot, not including the service area. Floor loading must be less than 250lbs per square foot, including the service area. There can be a total of 6 JBODs or 6 MIS Servers per D-Rack, or a combined total of 5. For maximum efficiency and performance, it is suggested that the maximum number of enclosures in a single D-Rack is 1 MIS Dual Server enclosure with 4 JBODs (two JBODs per server module). A 5th JBOD can be tolerated weight-wise, but 4 is the suggested performance maximum.

The System Overview will first explore the “MIS Enclosure,” including “Front Grille and Control Panels” on page 6, “Rear Panel Components” on page 7. Next, the “MIS Common Modules” on page 10 is covered, including the power supply modules, fan modules, and StorBrick modules. “MIS Server Platform or JBOD Unit” on page 14, discusses the presence of the “Server Module” on page 14, its available features and associated “Boot Drives Module” on page 22, or the

presence of a ninth StorBrick and “MIS JBOD I/O Module” on page 22. Finally, a “System Block Diagram” on page 23 is given, showing a diagram of the enclosure with a dual-server configuration (optional JBOD components show in grey), signals and power connections.



Figure 1-1 SGI Destination Rack (D-Rack)

MIS Enclosure

The MIS enclosure, whether it is a server or JBOD, consists of a chassis, case (with front bezel grille, control panel and rear ports).



Figure 1-2 MIS Chassis and Case

The SGI MIS chassis features a front bezel display with an internal EMI grille (Figure 1-2). The unique bi-directional sliding rail mounts (Figure 1-3) allow the unit to be slid forwards 20" or backwards 18" to access disk drives and other serviceable components. This also makes for an overall safer rack design, as chassis do not need to be extended their full length to be serviced.



Figure 1-3 Bi-directional rail mount

Front Grille and Control Panels

Next to the bezel grille, up to two control panels can be present on the MIS Platform, one for each server in the MIS Server Platform, or one for each I/O unit on the MIS JBOD. Figure 1-4 shows a single control panel and Figure 1-5 shows two control panels.

Each control panel has a Power LED, Power button, Status LED, Reset Button, Locator LED, Locator button, Network Activity LED, Boot Drive Activity LED, and NMI Reset button (to be used by SGI field operatives only). Indicator light meanings and button functions are explained in, “Control Panel” in Chapter 2.

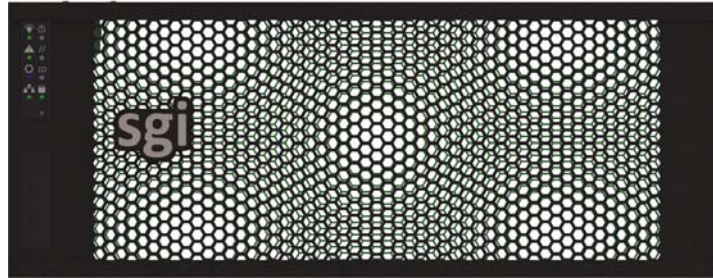

Figure 1-4 Single Control Panel

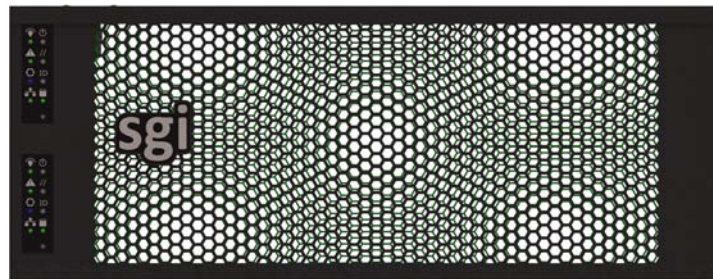

Figure 1-5 Dual Control Panel

Rear Panel Components

The appearance of the rear panel on the MIS chassis will depend on what modules are installed. An MIS Platform can have up to four power supplies, each with their own AC power inputs (only two are pictured in any of the figures here). They are high-efficiency, hot-swappable power supplies rated at 1100 Watts.

All rear panels feature clearly silk-screened labels next to the port in question. The MIS Server Platform (single server) in Figure 1-6, features a single server module with two USB ports, a video port, and two NIC ports. Figure 1-7 show a MIS Server Platform with the optional four power supplies. The MIS Server Platform (dual server) rear panel as shown in Figure 1-8 has a second server module with its own set of USB ports, video port, and NIC ports. Figure 1-9 shows an MIS Server Platform (single dual-server module) which features dual server construction with a single server installed, and the option of upgrade to include a second server later. Figure 1-11 shows the rear panel of the MIS JBOD with two I/O modules.

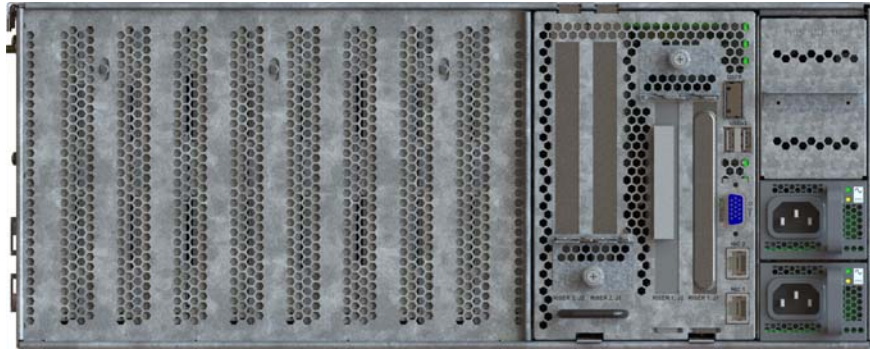

Figure 1-6 Rear View – MIS Server Platform (single server)

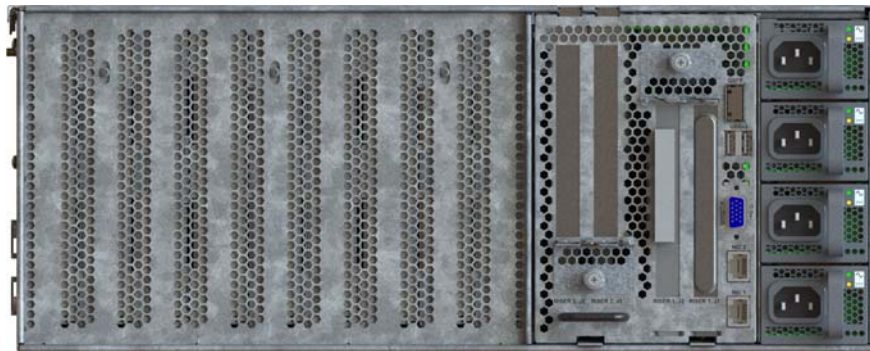

Figure 1-7 Rear View – MIS Server Platform (single server, four power supplies)

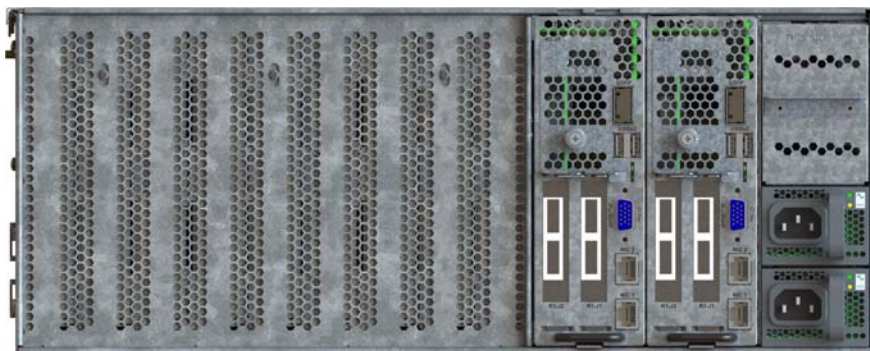

Figure 1-8 Rear View – MIS Server Platform (dual server)

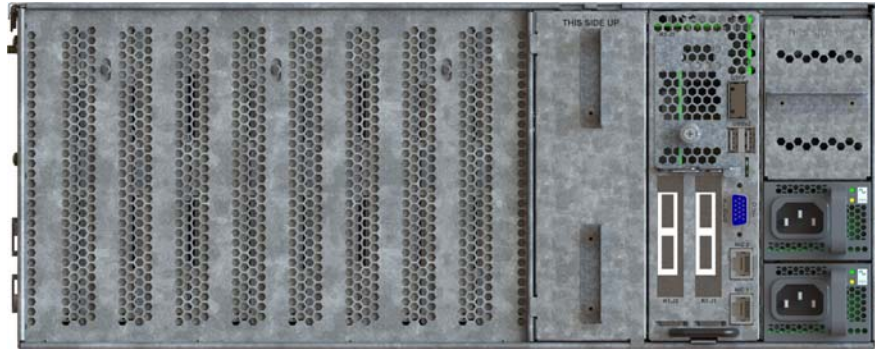

Figure 1-9 Rear View – MIS Server Platform (single dual-server module)

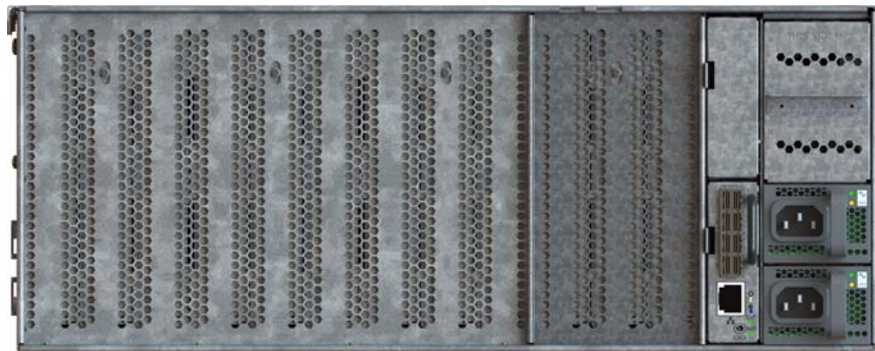

Figure 1-10 Rear View – MIS JBOD Unit (single I/O module)

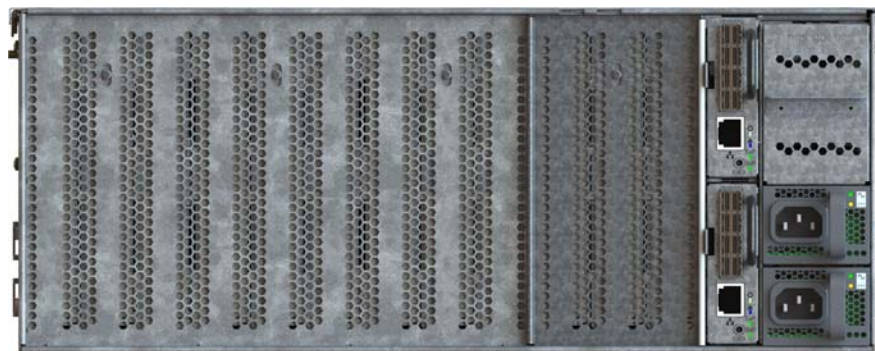

Figure 1-11 Rear View – MIS JBOD unit (dual I/O modules)

MIS Common Modules

This section describes the common internal modules of the MIS enclosure. Designed to deliver a high level of reliability, scalability and manageability, the MIS platform makes use of modules to contain key components. Whether the unit is an MIS Server or a JBOD, both chassis contain the following hot-swappable modules:

- Up to four power supplies (two redundant) (Figure 1-12);
- Six fan assemblies (Figure 1-14);
- Capacity drives installed in StorBricks (Figure 1-15).

The power supply modules are high-efficiency, hot-swappable power supplies rated at 1100 Watts, AC Input: 100–240 VAC (50-60Hz), single or three phase. There are six hot-swappable fan modules housing one fan with two counter-rotating impellers. And instead of the conventional disk architecture, the unique StorBrick modules—innovative, highly-dense drive modules used to house drive bays—allows the platform to maximize storage density.

Each MIS Server has eight StorBricks modules, and each MIS JBOD has nine, with the ninth module taking the place of the compute server module. Each StorBrick module holds up to nine 3.5" or 2.5" (15mm), SAS or SATA, rotational or SSD drives, or, using the dual-slot drive option, eighteen 2.5" (9.5mm), SAS or SATA, rotational or SSD drives.



Warning: Rotational SAS drives and rotational SATA drives cannot be included in the same inclosure due to vibration conflicts.

Power Supply Module

One to four power supplies provide power for the SGI MIS server. Power supplies are configured for N+N support. The power supplies provide 12VDC main power and 5VDC standby power. The power supplies are hot-swappable and can be replaced under full load. Power supplies are numbered 0-3 from the bottom up, on the rear panel of the enclosure (Figure 1-13).

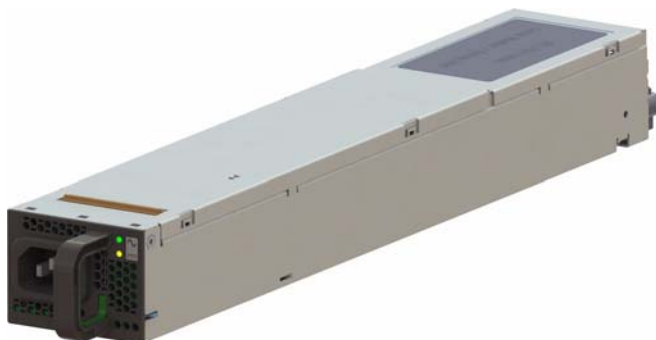

Figure 1-12 Power Supply Module (rated at 1100 Watts)

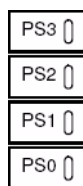

Figure 1-13 Power Supply Numbering

Fan Assembly Module



Figure 1-14 Fan Assembly Module (each contains two impellers)

Six fan assemblies mounted in the middle of the chassis cool the system. Each hot-swappable fan assembly contains two impellers. Air flows from the front to the back of the enclosure. The fan baseboard distributes power and control signals to the fan assemblies. Firmware on the fan baseboard monitors the fan speeds and temperatures within the enclosure. The SMS adjusts the individual fan speeds as needed to continuously provide optimal cooling for the enclosure.

StorBrick Module

Each StorBrick Module contains up to nine 3.5" or 2.5" 15mm drives (Figure 1-15), or eighteen 2.5" 9mm drives (), mounted in the StorBrick using proprietary drive carriers (Figure 1-16). A sliding thumb latch securely fastens the drive carriers in place (Figure 1-17, thumb latch is pictured in blue, but is grey on the actual product). StorBricks use SAS-2 protocol, which enables the system to use SAS and/or SATA drives (rotational disks or SSDs).

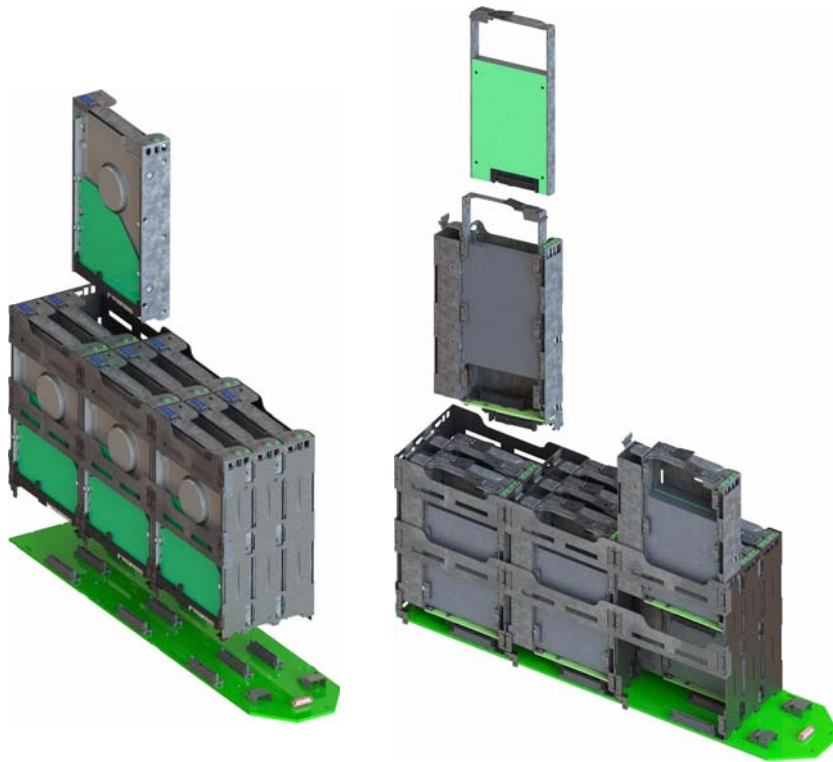

Figure 1-15 StorBrick Modules for 3.5" or 2.5" 15mm Drives (left) and 2.5" 9.5 mm Drives (right)



Warning: Rotational SAS drives and rotational SATA drives cannot be included in the same inclosure due to vibration conflicts.



Figure 1-16 3.5" 15mm Drive and Carrier



Figure 1-17 3.5" 15mm Drive Carrier (top view, with thumb latch)

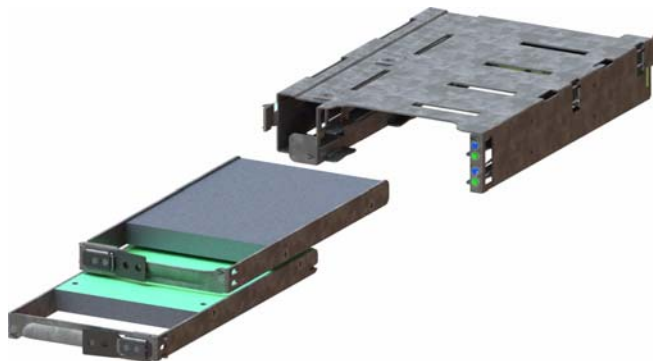

Figure 1-18 Two 2.5" 9.5mm Drives and Carrier



Figure 1-19 2.5" 9.5mm Drive Carrier (isometric view with dual thumb latches)

MIS Server Platform or JBOD Unit

The key difference between the MIS Server Platform (Figure 1-20 or Figure 1-21) and the MIS JBOD Unit (Figure 1-22) is the presence of the compute server module (Figure 1-23 or Figure 1-25) and boot drives (Figure 1-29) in the Server Platform, or a ninth StorBrick (Figure 1-15) and I/O modules (Figure 1-30) and associated midplane (Figure 1-31) in the JBOD.

Server Module

The MIS Server Platform can be single- or dual-server (Figure 1-23 or Figure 1-25) depending on whether it has one or two compute server modules. Each compute server module can have:

- Up to two Intel® Xeon® E5-2600 series processors per motherboard, with Intel Turbo Boost Technology 2.0: if the cores are operating below power, current, and temperature specs (< 35°C ambient) limits, they automatically run faster than base operating speed.
- 8 DDR3 DIMMs (4 GB, 8 GB, or 16 GB) for a single-server board configuration. Up to 16 DIMMs for a dual-server board configuration,
- Up to 4 HBAs for a single server, full-height (4.25") and half-depth (3.375"), externally or internally facing. Up to 4 HBAs (half-height, half-depth; 2 per server module) for a dual server. (See Figure 1-27 on page 20)
- Up to three PCIe riser cards for a single server (dual servers have a mandatory 3 PCIe risers).
- Up to four battery back up units for a single server module. Up to three battery back up units per server module for a dual server platform, for a total maximum of six. (Unique BBU PCIe technology allows the inclusion of BBUs without the consumption of any of the available PCIe slots.)

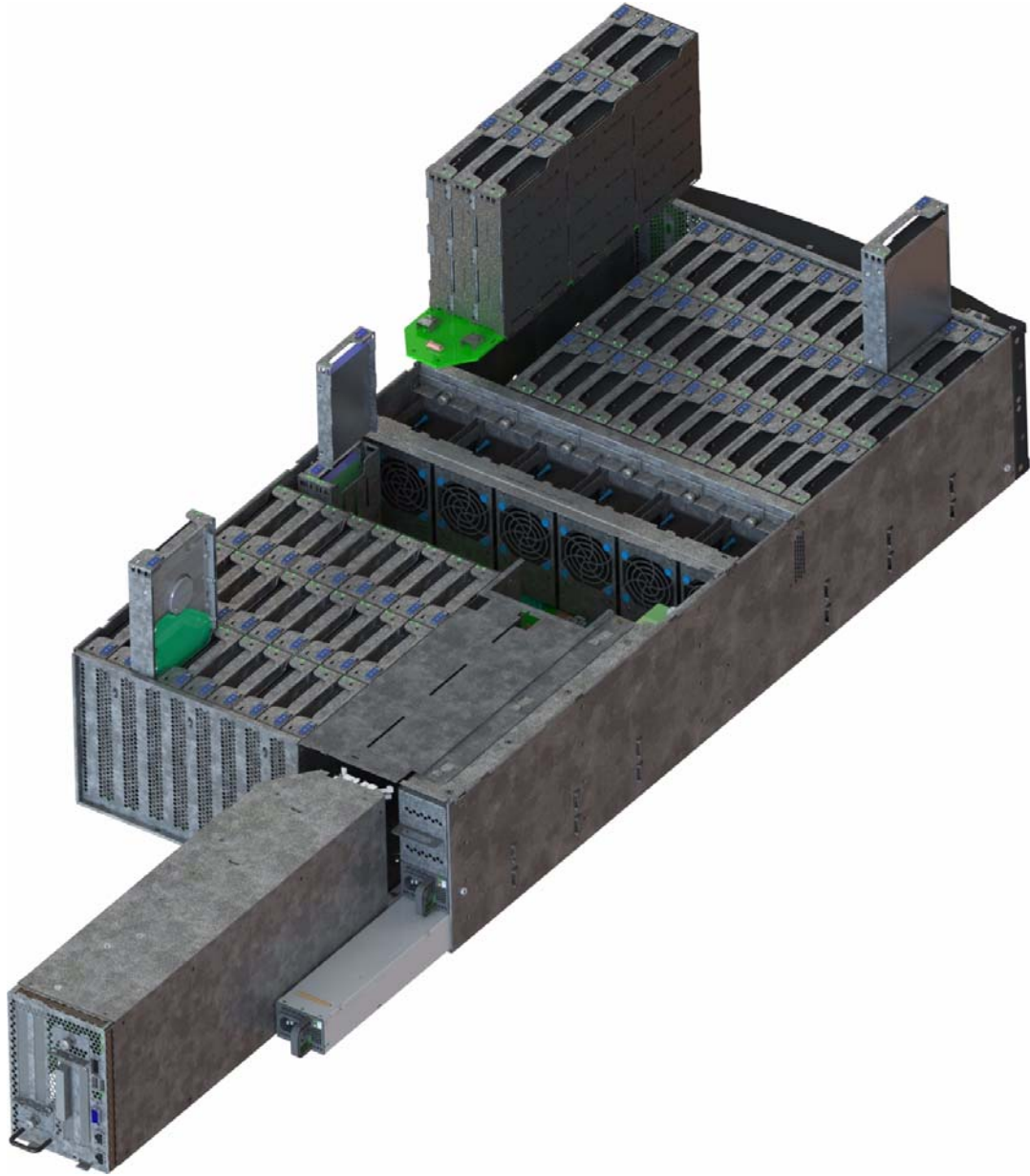

Figure 1-20 MIS Server Platform (single server)

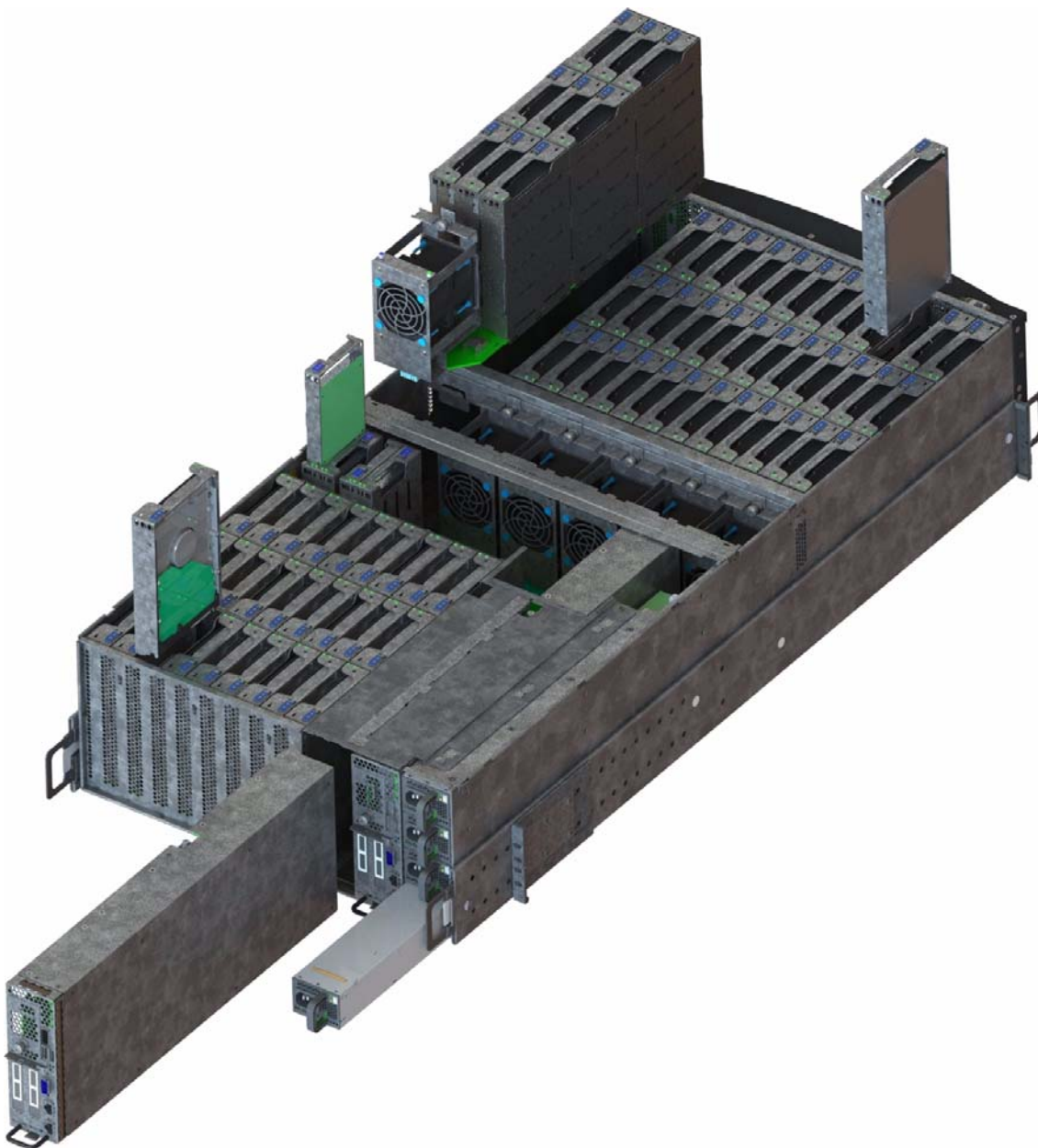

Figure 1-21 MIS Server Platform (dual server)

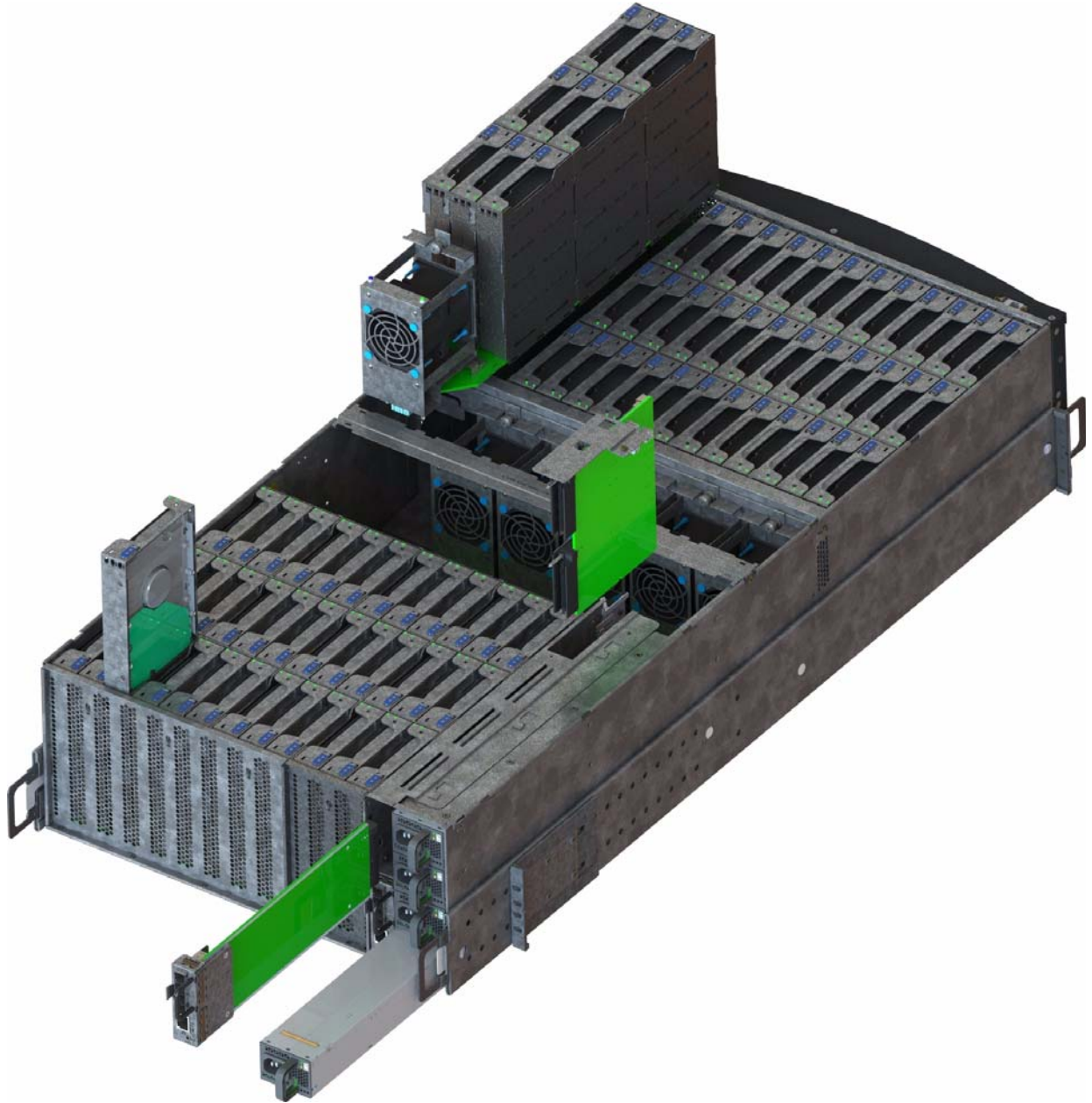

Figure 1-22 MIS JBOD Unit

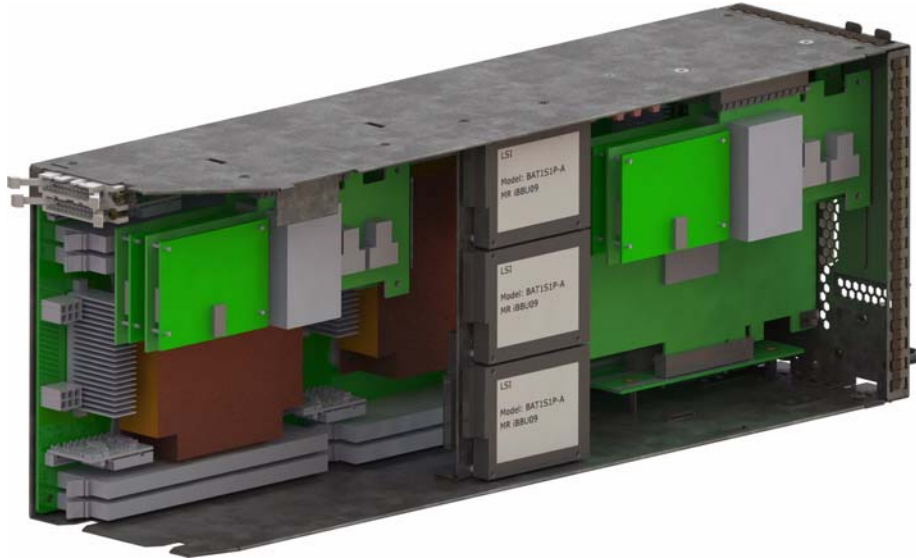

Figure 1-23 MIS Server Module – single server

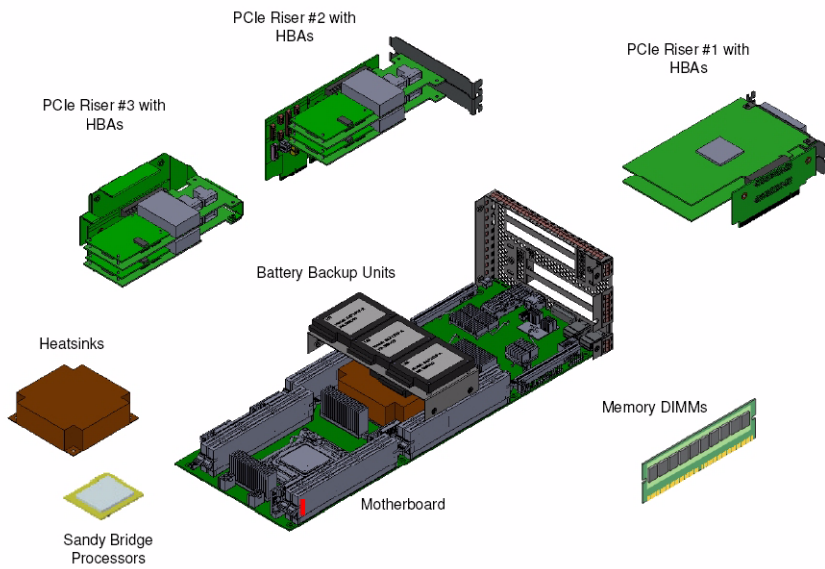

Figure 1-24 Server Module (single server) – component view

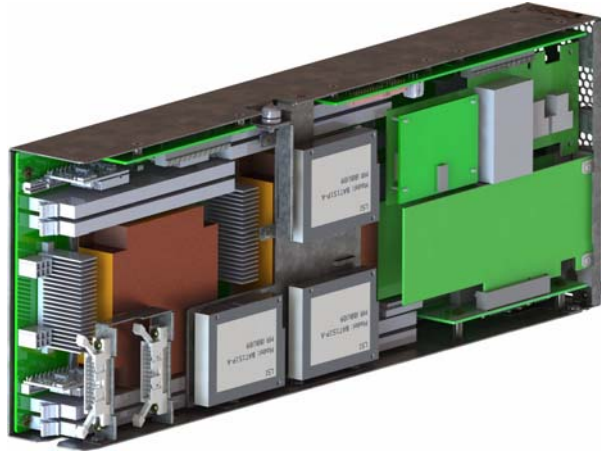

Figure 1-25 MIS Server Module – dual server (half height)

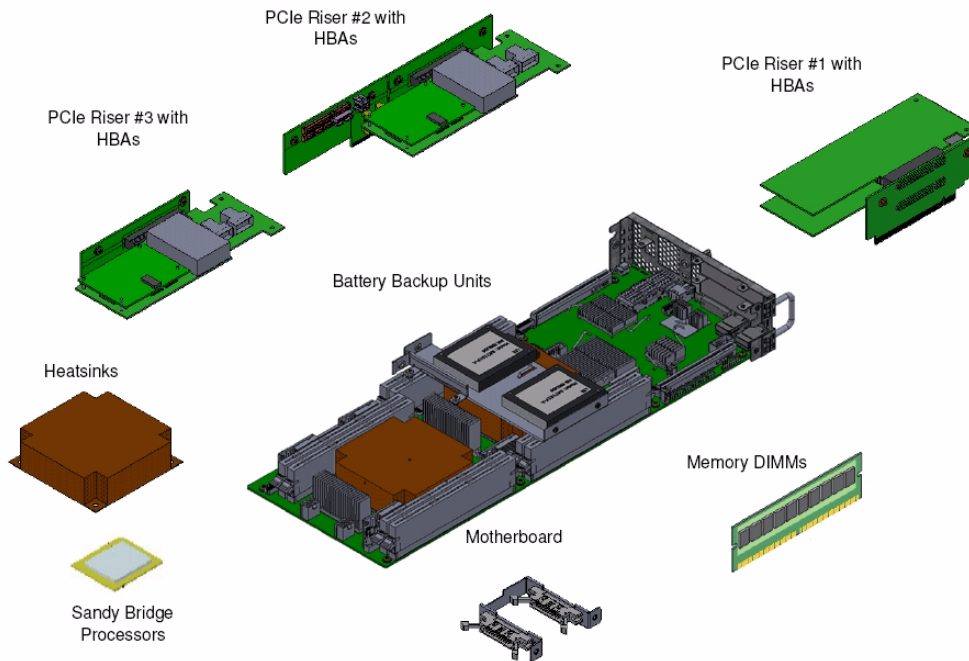

Figure 1-26 Dual Server Module – component view

Layout of Server CPUs, and PCIe Risers HBAs

Figure 1-27 shows the CPU and riser layout. Because of cabling restrictions in a single server, single CPU systems, only two internal SAS HBAs are allowed. The first CPU handles Riser 1 and 2. The optional second CPU would manage Riser 3. If the second CPU is not installed, Riser 3 is non-operational. When a second CPU is installed, HBAs populated on Riser 3 are internal facing SAS HBAs only, which connect to the StorBricks (Figure 1-28).

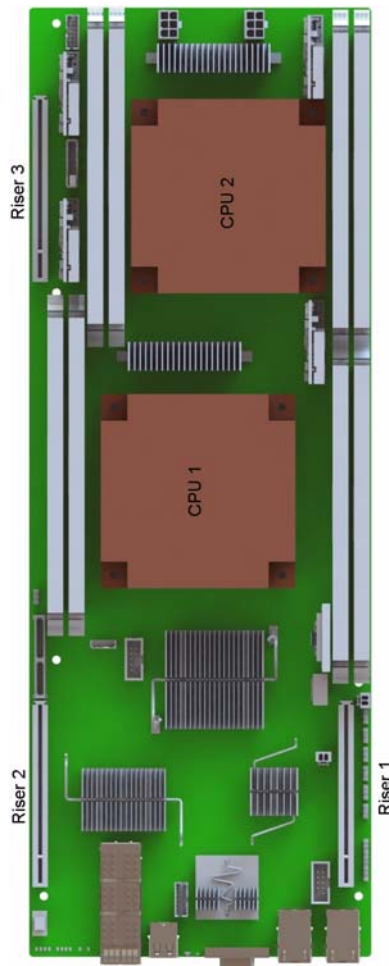
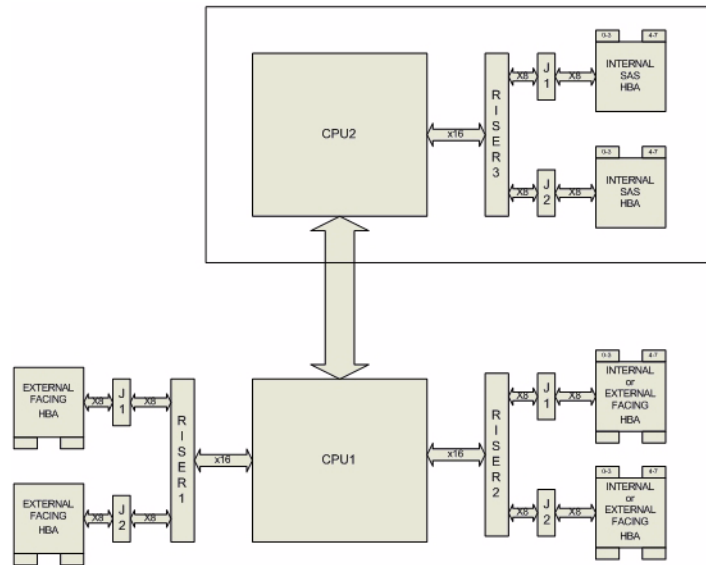

Figure 1-27 CPU and PCIe Riser layout



Dual CPUs:
 RISER2-J1 is reserved for a internal SAS HBA and when populated connects to the StorBricks
 RISER2-J2 is reserved for a internal SAS HBA and when populated connects to the StorBricks
 RISER1-J1 can be populated with external facing HBAs
 RISER1-J2 can be populated with external facing HBAs
 If a internal SAS HBA is not populated in RISER2-J2, an external HBA can be populated
 If a internal SAS HBA is not populated in RISER2-J1, an external HBA can be populated

Single CPU:
 RISER2-J1 is reserved for a internal SAS HBA and when populated connects to the StorBricks
 RISER2-J2 is reserved for a internal SAS HBA and when populated connects to the StorBricks
 RISER1-J1 can be populated with external facing HBAs
 RISER1-J2 can be populated with external facing HBAs
 If a internal SAS HBA is not populated in RISER2-J2, an external HBA can be populated

Figure 1-28 HBA population layout

Boot Drives Module

Each MIS Server Platform features two boot drives per server module (up to four total – mirrored using LSI software RAID 1). These drives are SAS or SATA, rotational or SSD, up to 300GB, used to store server data and the server operating system. Supported operating systems include:

- Microsoft® Windows® 2008 R2 SP1 (not shipped with product),
- Red Hat® Enterprise Linux (RHEL) 6.2,
- SUSE LINUX® Enterprise Server 11 SP1, or
- VMware® ESX 5.0

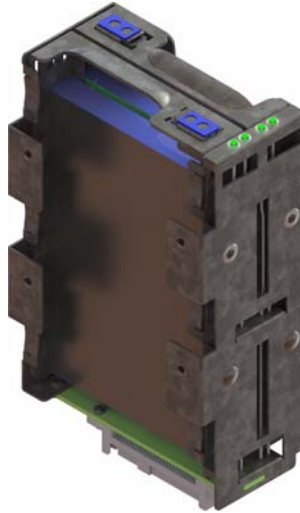

Figure 1-29 Boot Drive Module

MIS JBOD I/O Module

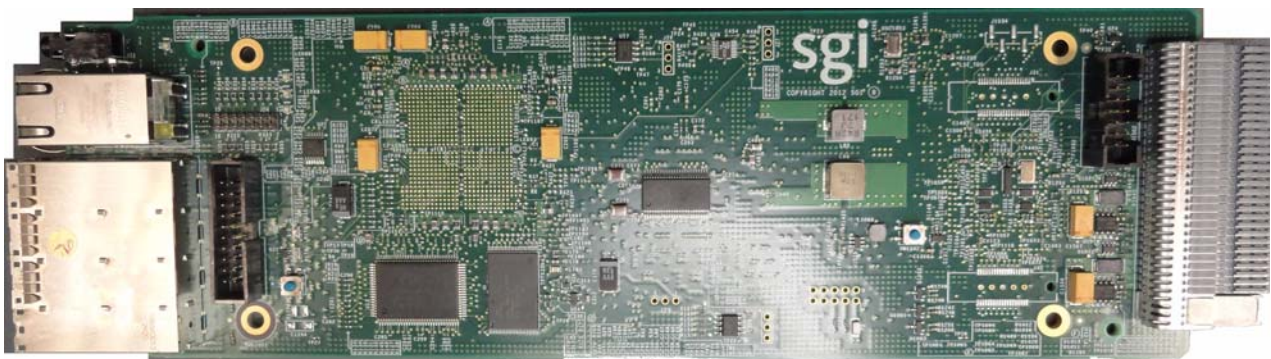

Figure 1-30 I/O Module for MIS JBOD Unit

JBOD I/O modules slide into a midplane (Figure 1-31), which connect to the SAS controllers.



Figure 1-31 MIS JBOD Midplane I/O Connector (right & left views)

System Block Diagram

Figure 1-32 shows the system-level block diagram for a fully populated dual-server (the optional JBOD components are shown in grey: “STORBRICK 8” and “JBOD only”).

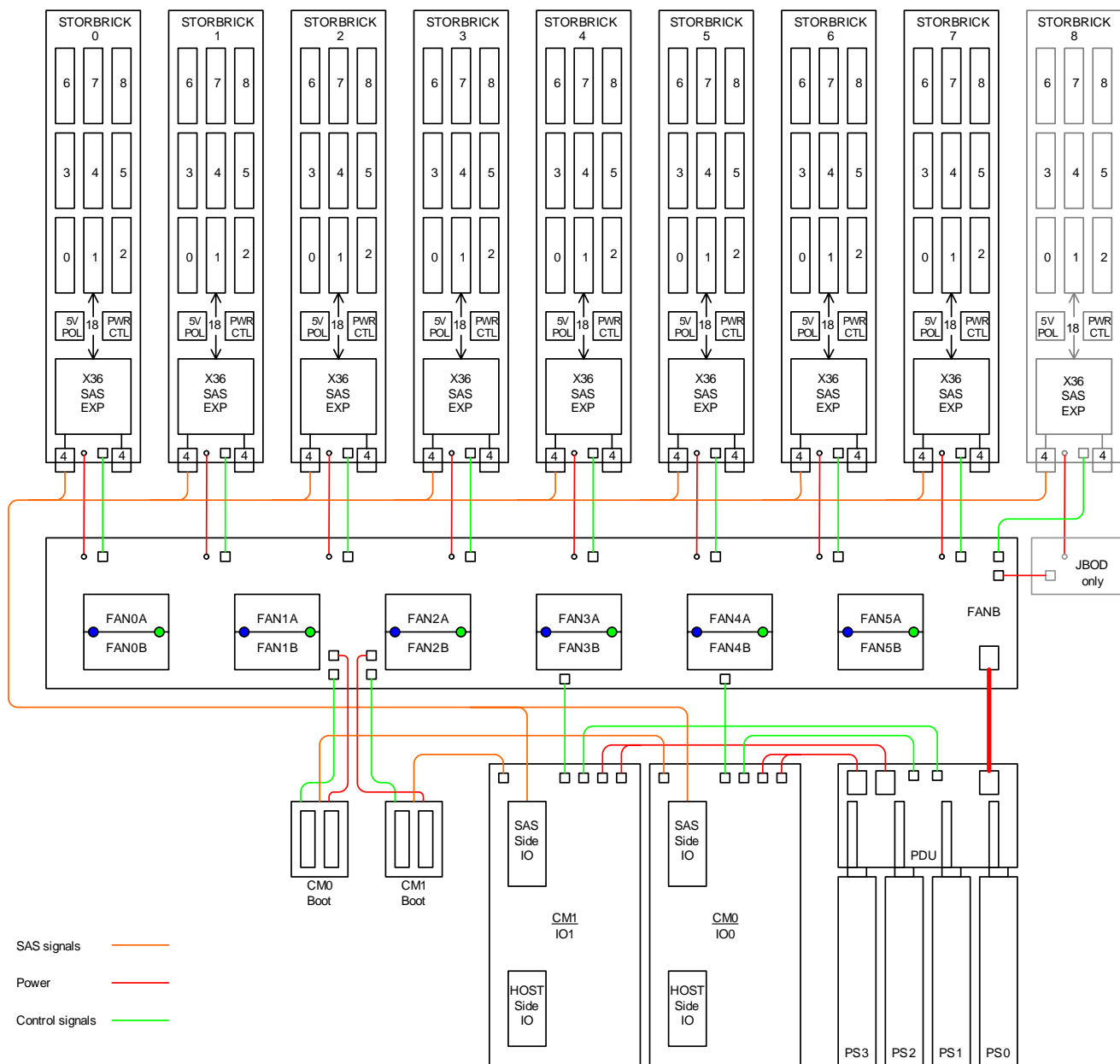

Figure 1-32 System-Level Block Diagram

Chapter 2

System Interfaces

This chapter describes the hardware and software interfaces of the MIS platforms. Both the MIS server platform and MIS JBOD storage unit have a front control panel, disk drive LED codes, and power supply LED codes. The control panel lights and buttons have different meanings and functions, depending on whether the machine is the MIS Server Platform or MIS JBOD unit. The disk drive LED codes and power supply LED codes remain the same whether the system is a server platform or JBOD unit. Additionally, there are four programs used to initialize and monitor the MIS machines. This chapter details the hardware interfaces, their functions and indications, as well as the Baseboard Management Controllers (BMC) Web Console. These programs provide power management features, environmental monitoring, etc.

Note: SGI provides features beyond those of IMPI 2.0, for instance, chassis intrusion detection, which will gracefully power down the system if the case cover is left off for more than 15 minutes.

Control Panel

MIS Server Control Panel

The control panel (Figure 2-1) interface consists of five indicator lights and four buttons. More information on remote functionality and the Web Console and Terminal Tool is presented at the end of this chapter.

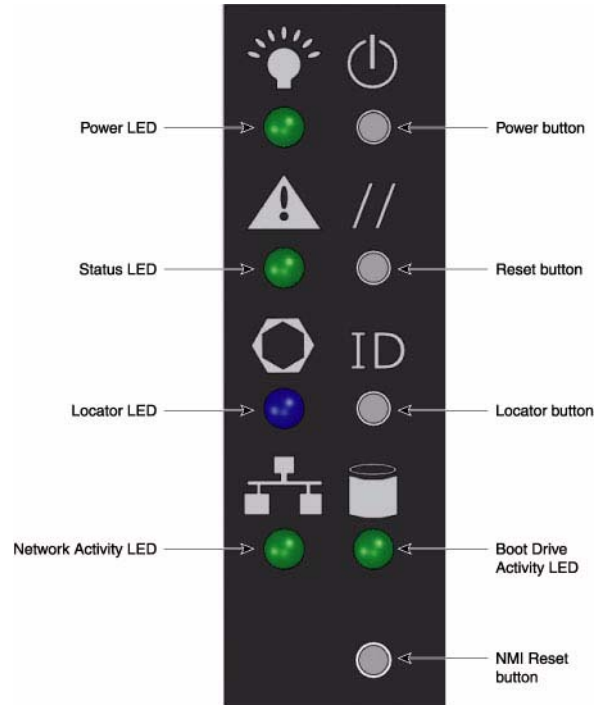

Figure 2-1 MIS Control Panel

The NMI Reset button (Non-Maskable Interrupt) should not be used, except under the direct supervision from technical support.

Table 2-1 MIS Server Platform Control Panel Buttons and LEDs

LED/Button	Description
Power LED	Green LED lit means power is on.
Power button	If the system is off, pushing this button powers on the system. If the operating system is running, pushing this button shuts down the operating system and powers off the system gracefully. If the operating system is hung, holding the button down for 10 seconds or more will power off the system for a hard reset.

Table 2-1 MIS Server Platform Control Panel Buttons and LEDs (continued)

LED/Button	Description
Status LED	This indicator will be lit whenever there is AC power available to the power supplies, whether the unit is on or off. Green means the system is in good working order. Yellow indicates a problem with the system, and service is required.
Reset button	The service reset button. When pushed, this button causes the server to reboot and, if the problem is cleared by the reset, returns the Status LED to green.
Locator LED	Blue LED is lit on the front and the back to help locate the unit in a rack or bay.
Locator button	The Locator LED will be lit blue when the Locator button is pushed. There is a corresponding LED on the back of the server that will be blue. When the Locator button is pushed again, the LED will go off. This function may also be activated remotely using the Intel BMC Web Console and pressing the virtual button, or using the Linux IPMI Terminal Tool: -H <ip address> -P <password> -U <user> chassis identification
NIC Activity LED	The green LED will be active whenever there is any network traffic occurring on the base board NIC ports.
Boot Drive Activity LED	The LED is lit whenever the boot drives are being accessed.
NMI Reset button	Used only under the direction of technical support personnel.

MIS JBOD Control Panel

The control panel (Figure 2-1) for the MIS JBOD is exactly the same as the MIS Server Platform. However, some of the buttons do not have the same function as they do on the MIS Server. Since there is no boot drive module in a JBOD, the Boot Drive Activity LED, located next to the Network Activity LED, is present, but inactive.

Important: When there are two I/O modules on a JBOD, the top control panel connects to the bottom I/O module on the back of the unit, and vice versa, the bottom control panel accesses the top I/O module.

Disk Drive LEDs

Figure 2-2 shows the green/yellow and blue disk drive LEDs.



Figure 2-2 Disk Drive LEDs

Table 2-2 describes the meaning of disk drive LEDs.

Table 2-2 Disk Drive LEDs

Bi-color LED	Blue LED	Drive Status
Off	Off	Drive is off and can be removed.
Green	Off	Drive is on.
Yellow	Off	Service required.
Off/Green/Yellow	On	Indicates drive location.

Power Supply LEDs

There are two LEDs located on the face plate of the power supply, one green on top, and one bi-color yellow/green below (Figure 2-3). Table 2-3 describes the function of the power supply LEDs

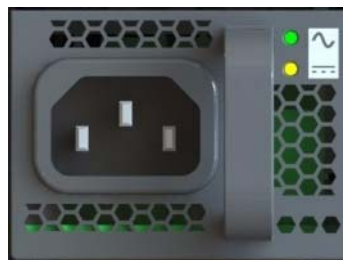

Figure 2-3 Power Supply LEDs

Table 2-3 Power Supply LEDs

Green LED	Bi-color LED	Power Supply Status
Off	Off	No AC power to the supply, power is off on the front of the machine.
Off	Yellow	Problem indicated (voltage, fan failure, AC failure, etc.)
On	Blinking Yellow	AC available, power supply in standby mode (powered off on the front)
On	Green	AC available to the power supply, power supply is on and functioning normally.

BMC Integrated Web Console

The control panel and various other LEDs are used to monitor the overall status of the system and its components. Underlying the light-guided diagnostics provided through the various LEDs on the control panel, power supplies, motherboard, etc. are the BMC/IPMI interfaces. The MIS server supports the platform management features (environmental monitoring, power management, etc.) provided by the Intel BMCs and IPMI 2.0. Moreover, the BMCs have features beyond those of IPMI 2.0 (for instance, detection of chassis intrusion).

The BMC Integrated Web Console is a web-based program provided by Intel, and is used to give general system information such as system diagnostics, server health, environmental reporting, and event logs. Additionally, the BMC-IWC provides a remote virtual control panel for the MIS Server, allowing for remote locating and reboot.

For more information, see the platform management documentation for the Intel S2600JF motherboard in *Intel Server Boards and Server Platforms Server Management Guide* (publication number 37830-002)

This section gives you a high-level description of each Integrated BMC Web Console page. It is organized in sections corresponding to the four tabs in the horizontal menu. Within each section, each menu on the left-hand side is illustrated and described in detail.

System Information

After login, by default, the BMC Web Console opens on the System Information page. The System information page displays a summary of the general system information. This includes the power status and the version of firmware, and has the following information about the server.

Table 2-4 System Information Details

Information	Details
Host Power Status	Shows the power status of the host (on/off).
RMM Status	Indicates if the Intel RMM4 card is present.
Device (BMC) Available	Indicates if the BMC is available for normal management tasks.
BMC FW Build Time	The date and time of the installed BMC firmware.
BMC FW Rev	Major and minor revision of the BMC firmware.
Boot FW Rev	Major and minor revision of the BOOT firmware.
SDR Package Version	Version of the Sensor Data Record.
Mgmt Engine (ME) FW Rev	Major and minor revision of the Management Engine firmware.
Overall System Health	Green/Yellow and Blue

In the left navigation pane, There are five menu options. After System Information comes FRU Information, System Debug Log, CPU Information, and DIMM information.

System Information
This section contains general information about the system.

Summary

System Information

- FRU Information
- System Debug Log
- CPU Information
- DIMM Information

System Information

Host Power Status : **Host is currently ON**

RMM Status : Intel(R) RMM installed

Device (BMC) Available : Yes

BMC FW Build Time : Feb 22 2012 12:41:12

BIOS ID : SE5C600.86B.01.02.1003.041820121454

BMC FW Rev : 01.04.2896

Boot FW Rev : 01.07

SDR Package Version : Shackleford 1.05.02

Mgmt Engine (ME) FW Rev : 02.01.05.069

Overall System Health : ● ● ●

Figure 2-4 BMC Web Console – System Information Page

FRU Information

The Field Replaceable Unit (FRU) Information page displays information from the FRU repository of the host system.

FRU Chassis Information includes: Type, Part/Model Number, and Serial Number. **FRU Board Information** includes: Manufacturing Date, Manufacturer, Product Name, Serial Number, Part/Model Number, and FRU File ID. **FRU Product Information** includes: Manufacturer, Name, Part/Model Number, Version, Serial Number, Asset Tag, and FRU File ID.

System Information
This section contains general information about the system.

FRU Information

System Information
FRU Information
 System Debug Log
 CPU Information
 DIMM Information

Chassis Information
 Type: Main Server Chassis
 Part/Model Number: loose_some
 Serial Number: win_some

Board Information
 Manufacturing Date : 2012-03-26 15:06
 Manufacturer : Intel Corporation
 Product Name : S2600JF
 Serial Number: Q5JP14101366
 Part/Model Number : G28033-502
 FRU File ID : FRU Ver 0.01

Product Information
 Manufacturer : Intel Corporation
 Name : S2600JF
 Part/Model Number :

Figure 2-5 BMC Web Console – FRU Information

System Debug Log

The System Debug Log page allows administrators to collect system debug information. This feature allows a user to export data into a file that is retrievable for the purpose of sending to an Intel engineer or Intel partners for enhanced debugging capability. Select either the “System Debug Log” or the “System & BMC Debug Log” and press the **Run** button. It may take some time for the debug information to be collected.

The files are compressed, encrypted, and password protected. The file is not meant to be viewable by the end user but rather to provide additional debugging capability to your system manufacturer or an Intel support engineer. Once the debug log dump is finished you can click the debug log filename to save the results as a .zip file on your client system. The file can then be sent to your system manufacturer or an Intel support engineer for analysis.

System Debug Log Type

The System Debug Log data is mainly used by the system manufacturer for analysis. Baseboard Management Controller (BMC) status, BMC configuration settings, BMC Sensor readings, Power supply data, System Event Log, sensor readings, SMBIOS tables, CPU machine check registers

and PCI configuration space information. The System & BMC Debug Log contains regular System Debug Log plus the BMC debug log.

Last Log

Shows the time of the last data collection. Collection times older than three minutes will be marked as an “Old” debug log.

Encryption

The resulting zip file will be encrypted for privacy, and may only be extracted for analysis by an authorized representative of the system manufacturer.

Generate Log

Click the Generate Log button to collect recent Debug Log data. The resulting compressed archive will be downloaded to your system by clicking on the debug log link. You may also choose to download the data at a later time using the debug log link. Note that it is recommended that fresh data always be downloaded for analysis.

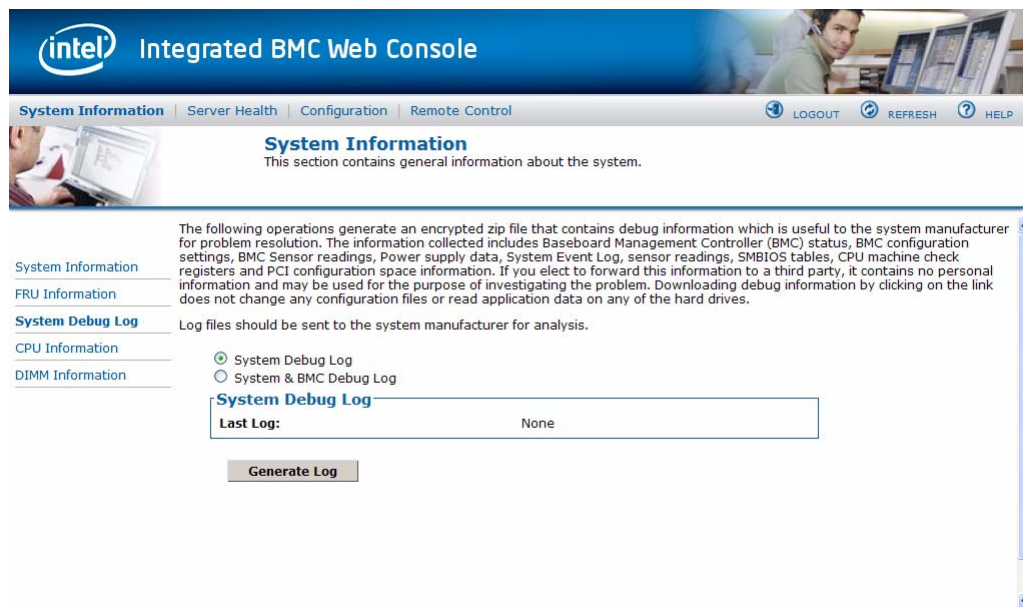

Figure 2-6 BMC Web Console – System Debug Log

CPU Information

The CPU Information page displays information on the processor(s) installed in the server.

The data in the CPU Asset Information page is collected from SMBIOS entries sent from the BIOS to the Baseboard Management Controller at the end of POST. If there is no data available, or the data is stale, please reset the system, allow it to complete POST, and refresh the page using the refresh button above.

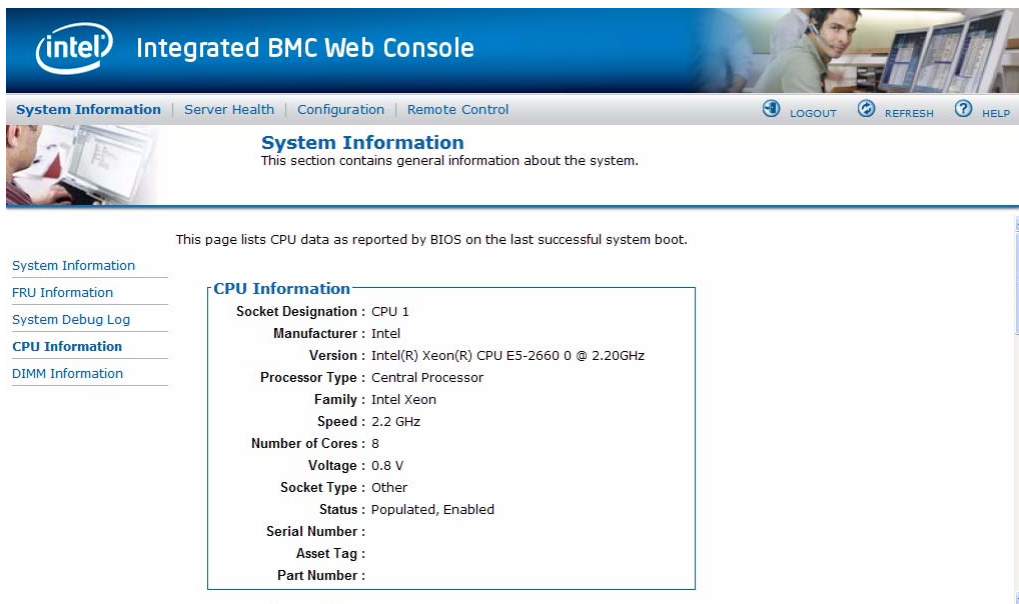
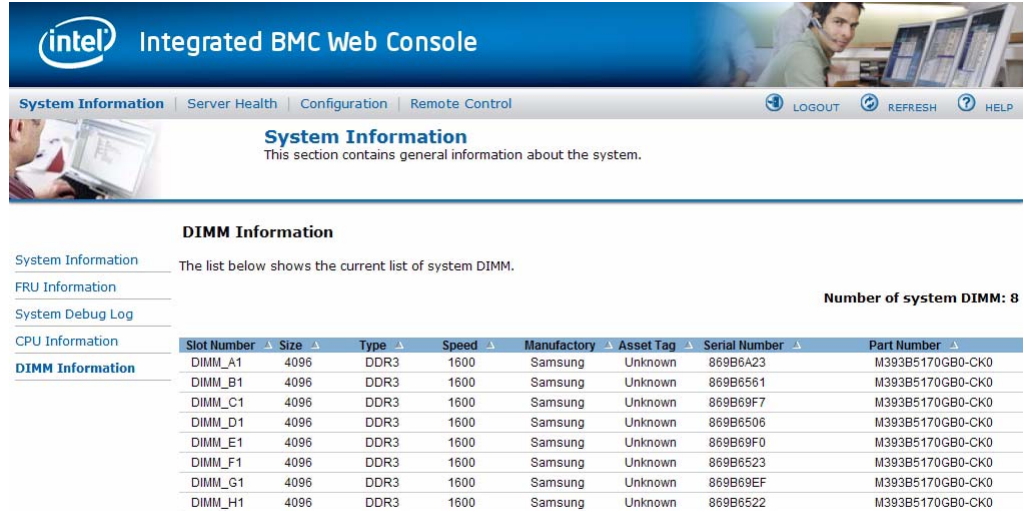

Figure 2-7 BMC Web Console – CPU Information

DIMM Information

The DIMM Information page displays information on DIMM modules installed on the host system.

Slot Number is DIMM location on the motherboard. The location is marked as A0, B1 and so on.



System Information
This section contains general information about the system.

DIMM Information

The list below shows the current list of system DIMM.

Number of system DIMM: 8

Slot Number	Size	Type	Speed	Manufacture	Asset Tag	Serial Number	Part Number
DIMM_A1	4096	DDR3	1600	Samsung	Unknown	869B6A23	M393B5170GB0-CK0
DIMM_B1	4096	DDR3	1600	Samsung	Unknown	869B6561	M393B5170GB0-CK0
DIMM_C1	4096	DDR3	1600	Samsung	Unknown	869B69F7	M393B5170GB0-CK0
DIMM_D1	4096	DDR3	1600	Samsung	Unknown	869B6506	M393B5170GB0-CK0
DIMM_E1	4096	DDR3	1600	Samsung	Unknown	869B69F0	M393B5170GB0-CK0
DIMM_F1	4096	DDR3	1600	Samsung	Unknown	869B6523	M393B5170GB0-CK0
DIMM_G1	4096	DDR3	1600	Samsung	Unknown	869B69EF	M393B5170GB0-CK0
DIMM_H1	4096	DDR3	1600	Samsung	Unknown	869B6522	M393B5170GB0-CK0

Figure 2-8 BMC Web Console – DIMM Information

Server Health

The Server Health tab shows you data related to the server's health, such as sensor readings, the event log, and power statistics as explained in the following sub sections. Click on the Server Health tab to select the various pages. By default, this tab opens the Sensor Readings page.

Sensor Readings

The Sensor Readings page displays system sensor information including status, health, and reading. By default the sensor readings are updated every 60 seconds but this can be changed by entering a value in the Set auto-refresh in seconds selection box and then pressing the **Set** button.

Sensor Selection drop-down box allows you to select the type of sensor readings to display in the list. The default is set to All Sensors, with other options: Temperature Sensors, Voltage Sensors, Fan Sensors, Physical Security, Processor, Power Unit, Memory, Event Logging Disable, System Event, Button/Switch, Module/Board, Watchdog Sensor, Management Subsystem Health, Node Manager, and SMI.

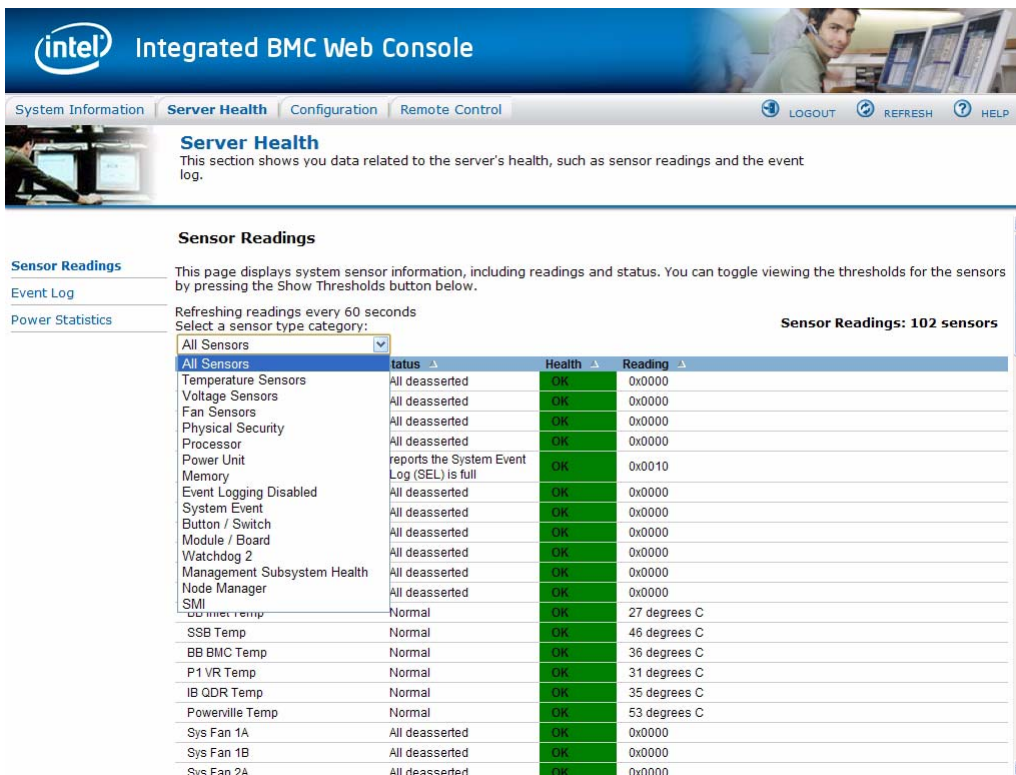

Figure 2-9 BMC Web Console – Server Health

Click **Show Thresholds** to expand the list, showing low and high threshold assignments. Use scroll bar at bottom to move display left and right.

- CT: Critical threshold
- NC: Non-critical threshold

Click **Hide Thresholds** to return to original display, hiding the threshold values, showing only the name, status and reading for selected sensors. Click **Refresh** to refresh the selected sensor readings.

Event Log

The Event Log is a table of the events from the system's event log. You can choose a category from the pull-down box to filter the events, and also sort them by clicking on a column header.

The filters available are All Events, Sensor-Specific Event, BIOS Generated events, and System Management Software Events. Use this page to view and save the Event log. **Event Log Category** selects the type of events to display in the list. **Event Log List** is a list of the events with their ID, time stamp, sensor name, sensor type, and description. Click **Clear Event Log** to clear the event logs. Click on **Save Event Log** to download the event logs to local system.

Event Log

Below is a table of the events from the system's event log. You can choose a category from the pull-down box to filter the events, and also sort them by clicking on a column header.

Select an event log category:

Event Log: 3639 event entries

	Sensor Name	Sensor Type	Description	
	B Temp	Temperature	reports the sensor is in a low, critical, and going lower state - Deasserted	
	SSB Temp	Temperature	reports the sensor is in a low, critical, and going lower state - Asserted	
3637	05/11/2012 20:39:07	SSB Temp	Temperature	reports the sensor is in a low, but non-critical, and going lower state - Asserted
3636	05/11/2012 20:39:01	SSB Temp	Temperature	reports the sensor is in a high, but non-critical, and going higher state - Deasserted
3635	05/11/2012 20:39:00	SSB Temp	Temperature	reports the sensor is in a high, but non-critical, and going higher state - Asserted
3634	05/11/2012 20:38:41	SSB Temp	Temperature	reports the sensor is in a low, but non-critical, and going lower state - Deasserted
3633	05/11/2012 20:38:41	SSB Temp	Temperature	reports the sensor is in a low, critical, and going lower state - Deasserted
3632	05/11/2012 20:38:40	SSB Temp	Temperature	reports the sensor is in a low, critical, and going lower state - Asserted
3631	05/11/2012 20:38:40	SSB Temp	Temperature	reports the sensor is in a low, but non-critical, and going lower state - Asserted
3630	05/11/2012 20:38:32	SSB Temp	Temperature	reports the sensor is in a low, but non-critical, and going lower state - Deasserted
3629	05/11/2012 20:38:32	SSB Temp	Temperature	reports the sensor is in a low, critical, and going lower state - Deasserted
3628	05/11/2012 20:38:31	SSB Temp	Temperature	reports the sensor is in a low, critical, and going lower state - Asserted
3627	05/11/2012 20:38:31	SSB Temp	Temperature	reports the sensor is in a low, but non-critical, and going lower state - Asserted

Figure 2-10 BMC Web Console – Event Log

Power Statistics

This section shows you data related to the server's health, such as sensor readings and the event log. Use this page to determine server power usage. In order to collect readings for this page, a PMBus enabled power supply must be attached to the server, and the server must be in a ACPI S0 (DC power on) state to report statistics data. System Power Statistics include:

- **Minimum:** Calculated as a minimum value of all power readings since last statistics reset.

- Current: Present power reading.
- Maximum: Calculated as a maximum value of all power readings since last statistics reset.
- Average: Calculated as the arithmetic average of all power readings since last statistics reset.

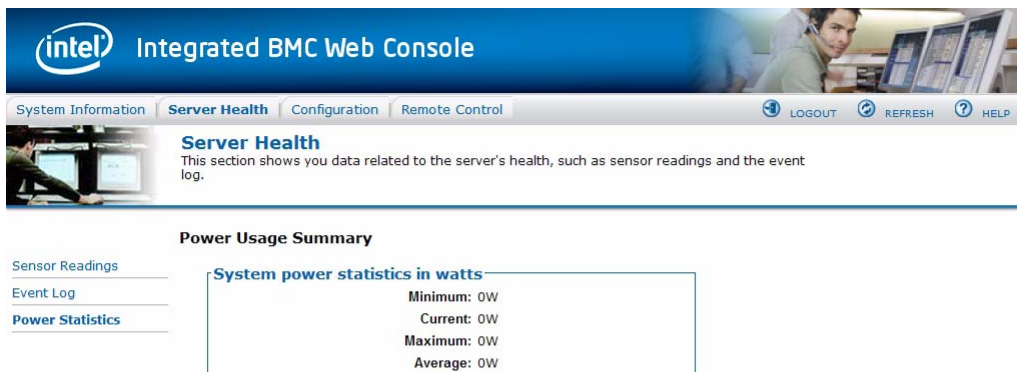

Figure 2-11 BMC Web Console – Power Statistics

Configuration Tab

The Configuration tab of the BMC Web Console is used to configure various settings, such as alerts, users, or network. It contains the following menu options in the left navigation pane: IPv4 Network, IPv6 Network, Users, Login, LDAP, VLAN, SSL, Remote Session, Mouse Mode, Keyboard Macros, Alerts, Alert Email, Node Manager.

IPv4 Network

Use this page to configure the network settings for server management.

Enable LAN Failover

Enabling failover bonds all available ethernet interfaces into the first LAN Channel. When the primary interfaces lease is lost one of the secondary interfaces is activated automatically with the same IP address.

LAN Channel Number

It lists the LAN Channel(s) available for server management. The LAN channels describe the physical NIC connection on the server. Intel® RMM channel is the add-in RMM NIC. The Baseboard Management channel is the onboard, shared NIC configured for management and shared with the operating system.

MAC Address

The MAC address of the device (read only).

IP Address

Select the type of IP assignment with the radio buttons. If configuring a static IP, enter the requested IP Address, Subnet Mask, Gateway, Primary DNS and Secondary DNS Server in the given fields.

- IP Address made of 4 numbers separated by dots as in xxx . xxx . xxx . xxx.
- 'xxx' ranges from 0 to 255.
- First 'xxx' must not be 0.

Caution: The RMM IP address must be on a different subnet than the baseboard IP address used for management traffic.

Configuration
Use these pages to configure various settings, such as alerts, users, or network.

IPv4 Network Settings

You can view and modify the IPv4 network settings on this page. Select whether to obtain an IP address automatically or manually configure one.

Enable LAN Failover

LAN Channel

MAC Address

Obtain an IP address automatically (use DHCP)
 Use the following IP address
 Disable LAN Channel

IP Address

Subnet Mask

Default Gateway

Primary DNS Server

Secondary DNS Server

Figure 2-12 BMC Web Console – IPv4 Network Settings

IPv6 Network

Use this page to configure the IPv6 network settings for server management.

Enable LAN Failover

Enabling failover bonds all available ethernet interfaces into the first LAN Channel. When the primary interfaces lease is lost one of the secondary interfaces is activated automatically with the same IP address.

LAN Channel Number

It lists the LAN Channel(s) available for server management. The LAN channels describe the physical NIC connection on the server. Intel® RMM channel is the add-in RMM NIC. The Baseboard Management channel is the onboard, shared NIC configured for management and shared with the operating system.

MAC Address

The MAC address of the device (read only).

Enable IPv6 on this Channel

This check box must be selected to enable any IPv6 network traffic on this channel.

IP Address configuration

IPv6 auto-configuration enables Stateless configuration using ICMPv6 router/neighbor discovery.

Obtain an IP address automatically enables DHCPv6.

Use the following IP address enables static IP assignment.

IP Address

Select the type of IP assignment with the radio buttons. If configuring a static IP, enter the requested IP Address, IPv6 prefix length, and optionally the Gateway in the given fields.

- IPv6 addresses consist of 8 4 digit hexadecimal numbers separated by colons.
- A :: can be used for a single sequence of two or more zero fields.

Caution: The RMM IP address must be on a different subnet than the baseboard IP address used for management traffic.

Configuration

Use these pages to configure various settings, such as alerts, users, or network.

IPv6 Network Settings

You can view and modify the IPv6 network settings on this page. Select whether to obtain an IP address automatically or manually configure one. IPv6 support must be enabled prior to it's configuration.

IPv6 Network

Enable LAN Failover

LAN Channel

MAC Address

Enable IPv6 on this Channel

- Use IPv6 auto-configuration (stateless ICMPv6 discovery)
- Obtain an IP address automatically (use DHCPv6)
- Use the following IP address

IP Address

IPv6 prefix length (0 to 128)

Gateway

Figure 2-13 BMC Web Console – IPv6 Network Settings

Users

The list of configured users, along with their status and network privilege is displayed. Use this page to configure the IPMI users and privileges for this server.

- **Add User** – Select an empty slot in the list and click to add a new user.
- **Modify User** – Select a user in the list and click to modify their settings.
- **Delete User** – Select a user in the list and click to delete.

Note: UserID 1 (anonymous) may not be renamed or deleted. UserID 2 (root) may not be renamed or deleted; nor can the network privileges of UserID 2 be changed.

Caution: User Names cannot be changed. To rename a User you must first delete the existing User, then add the User with the new name.

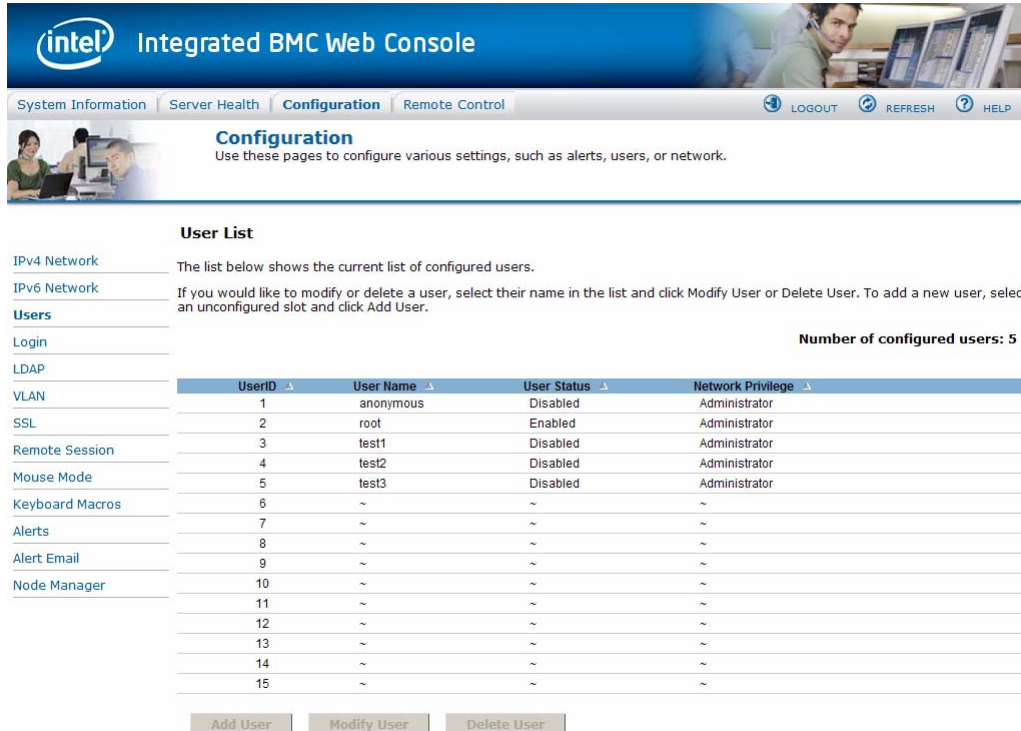

The screenshot shows the BMC Integrated Web Console interface. The top navigation bar includes 'System Information', 'Server Health', 'Configuration' (selected), and 'Remote Control'. Below the navigation bar, the 'Configuration' section is active, displaying a 'User List' table. The table lists 15 users with columns for UserID, User Name, User Status, and Network Privilege. The first five users are configured, while the remaining ten are marked with '~'. Below the table are buttons for 'Add User', 'Modify User', and 'Delete User'.

User List

The list below shows the current list of configured users.

If you would like to modify or delete a user, select their name in the list and click Modify User or Delete User. To add a new user, select an unconfigured slot and click Add User.

Number of configured users: 5

UserID	User Name	User Status	Network Privilege
1	anonymous	Disabled	Administrator
2	root	Enabled	Administrator
3	test1	Disabled	Administrator
4	test2	Disabled	Administrator
5	test3	Disabled	Administrator
6	~	~	~
7	~	~	~
8	~	~	~
9	~	~	~
10	~	~	~
11	~	~	~
12	~	~	~
13	~	~	~
14	~	~	~
15	~	~	~

Buttons: Add User, Modify User, Delete User

Login

Use this page to configure login security settings for server management.

Failed Login Attempts

Set the number of failed login attempts a user is allowed before being locked out. Zero means no lockout. Default is 3 attempts.

User Lockout Time (min)

Set the time in minutes that the user is locked out before being allowed to login again. Zero means no lockout and unlocks all currently locked out users. Default is 1 min.

Force HTTPS

Enable this option to force the User to user Secure Login for Web using HTTPS protocol. It will use the certificate uploaded under 'Configuration->SSL'.

Web Session Timeout

Set the maximum web service timeout in seconds. Timeout should be between 60 and 10800 seconds. Default timeout is 1800 seconds.

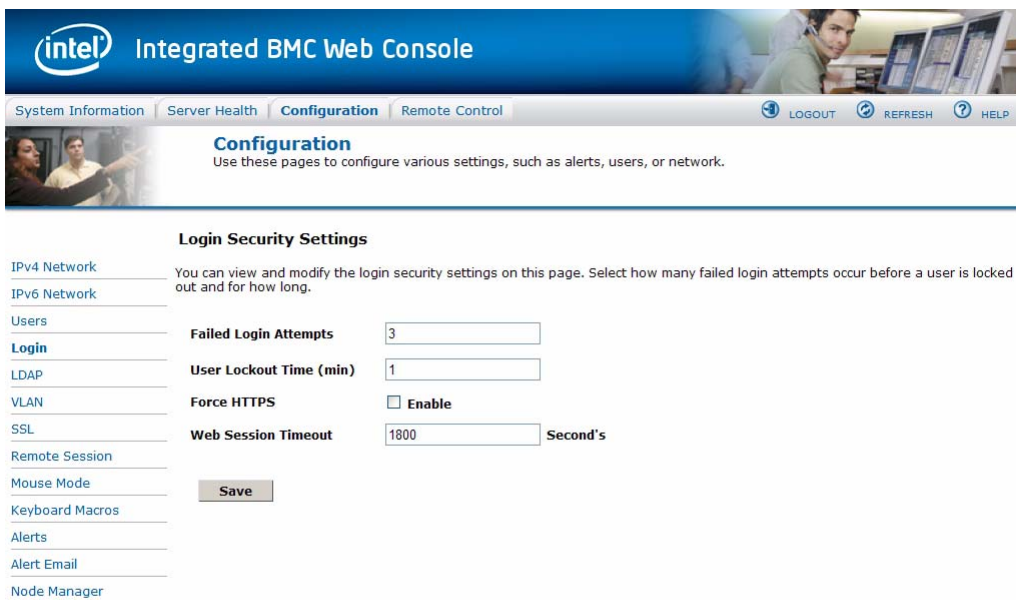

Figure 2-14 BMC Web Console – Login Security Settings

LDAP

To enable/disable LDAP, check or uncheck the **Enable LDAP Authentication** checkbox respectively.

LDAP Authentication

Check this box to enable LDAP authentication, then enter the required information to access the LDAP server.

Port

Specify the LDAP Port.

IP Address

The IP address of LDAP server

- IP Address made of 4 numbers separated by dots as in xxx . xxx . xxx . xxx.
- 'xxx' ranges from 0 to 255.
- First 'xxx' must not be 0.

Bind Password

Authentication password for LDAP server; the password must be at least 4 characters long.

Bind DN

The Distinguished Name of the LDAP server, e.g. cn=Manager , dc=my-domain , dc=com.

Searchbase

The searchbase of the LDAP server, e.g. dc=my-domain , dc=com.

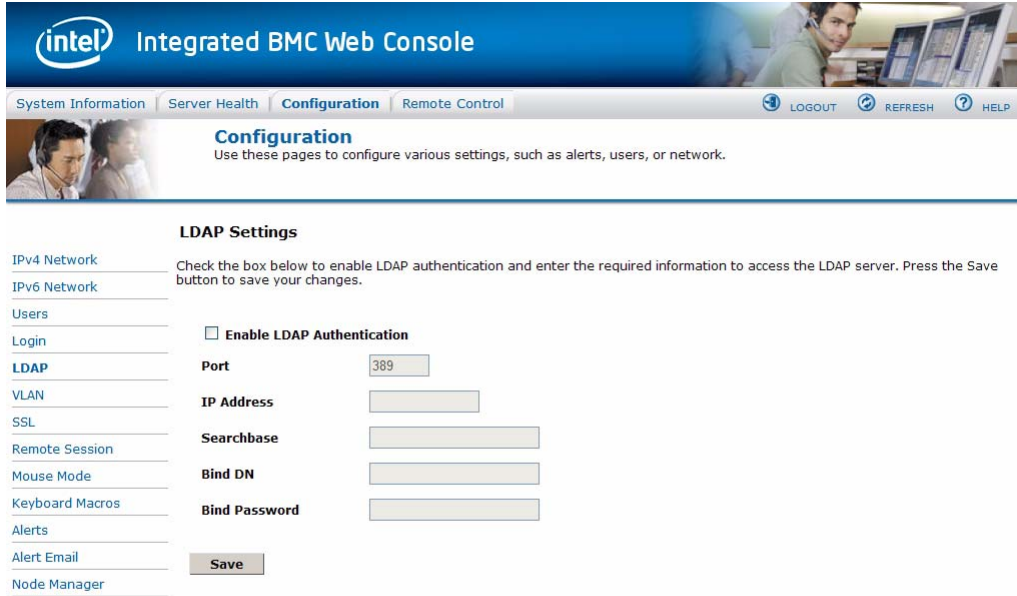

Figure 2-15 BMC Web Console – LDAP Settings

VLAN

Use this page to configure an 802.1Q VLAN private network on the specified LAN channel.

LAN Channel

It lists the LAN Channel(s) available for server management. The LAN channels describe the physical NIC connection on the server. Intel® RMM channel is the add-in RMM NIC. The Baseboard Mgmt channel is the onboard, shared NIC configured for management and shared with the operating system.

Enable VLAN

Check to enable VLAN on this channel. When enabled, the BMC only accepts packets with the correct VLAN Identifier field. All outgoing packets are marked with that VLAN ID.

VLAN ID

Specify the VLAN ID to use. Values are from 1 to 4094. Only one ID can be used at a time, and VLAN must first be disabled before a new ID can be configured on a given LAN channel.

VLAN Priority

Specify the VLAN Priority field to place in outgoing packets. Values are from 0 (best effort) to 7 (highest); 1 represents the lowest priority. 0 is the default.

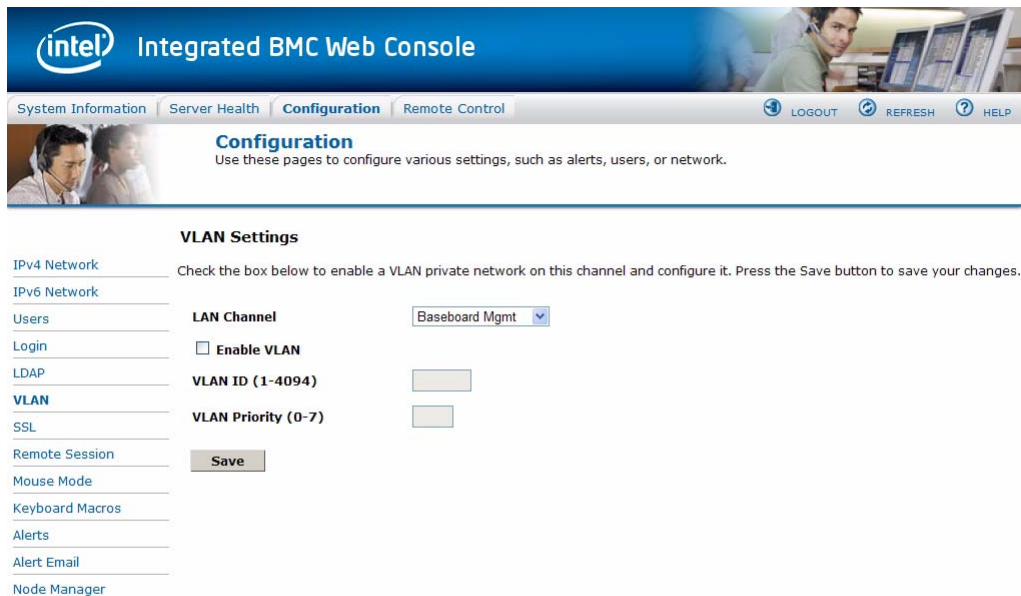

The screenshot displays the BMC Integrated Web Console interface. At the top, there is a navigation bar with the Intel logo and the text "Integrated BMC Web Console". Below this, a secondary navigation bar contains links for "System Information", "Server Health", "Configuration" (which is highlighted), and "Remote Control". On the right side of this bar are buttons for "LOGOUT", "REFRESH", and "HELP".

Below the navigation bar is a "Configuration" section with the heading "Configuration" and the subtext "Use these pages to configure various settings, such as alerts, users, or network." A list of configuration options is shown on the left side, including "IPv4 Network", "IPv6 Network", "Users", "Login", "LDAP", "VLAN" (which is selected and highlighted in blue), "SSL", "Remote Session", "Mouse Mode", "Keyboard Macros", "Alerts", "Alert Email", and "Node Manager".

The main content area is titled "VLAN Settings" and contains the following information:

- A checkbox labeled "Enable VLAN" is currently unchecked.
- A dropdown menu for "LAN Channel" is set to "Baseboard Mgmt".
- A text input field for "VLAN ID (1-4094)" is empty.
- A text input field for "VLAN Priority (0-7)" is empty.
- A "Save" button is located at the bottom of the configuration area.

Below the configuration area, a note states: "Check the box below to enable a VLAN private network on this channel and configure it. Press the Save button to save your changes."

Figure 2-16 BMC Web Console – VLAN Settings

SSL

The SSL Upload page shows dates for the default certificate and privacy key. Use this page to upload an SSL certificate and privacy key, which allows the device to be accessed in secured mode.

First upload the SSL certificate, and then device will prompt to upload privacy key. If either of the files are invalid the device will send a notification. The device will give notification on Successful upload. On successful upload device will prompt to reboot the device. If you want to reboot click **Ok** or click **Cancel** to cancel the reboot operation.

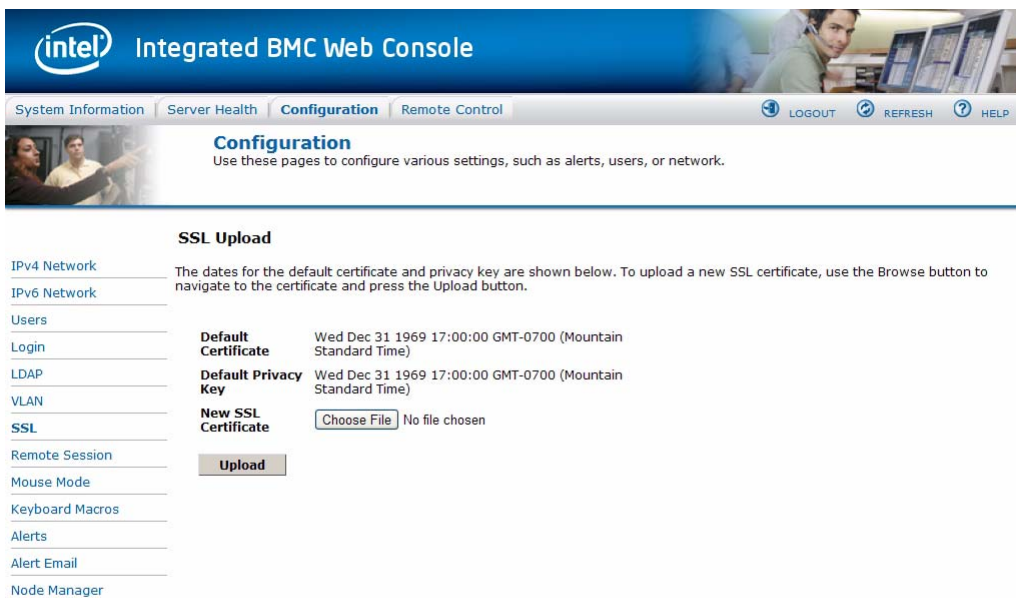

Figure 2-17 BMC Web Console – SSL Upload

Remote Session

Use this page to enable/disable encryption on KVM or Media during a redirection session.

KVM Encryption

Enable/Disable encryption on KVM data during a redirection session. Choose any one from the supported encryption techniques.

Keyboard/Mouse Only

If KVM Encryption is set to None, the Keyboard & Mouse data can still be encrypted using Blowfish encryption. This option has the least performance impact while still encrypting the most important data.

Media Encryption

Enable/Disable encryption of Media data during a redirection session. Disabling encryption can improve performance of KVM or Media redirection.

USB Key Emulation Mode

Two types of emulation are:

- Floppy - Emulated USB Key will be detected as Floppy drive in remote machine.
- Hard disk - Emulated USB Key will be detected as Hard disk (or) Removable drive in remote machine.

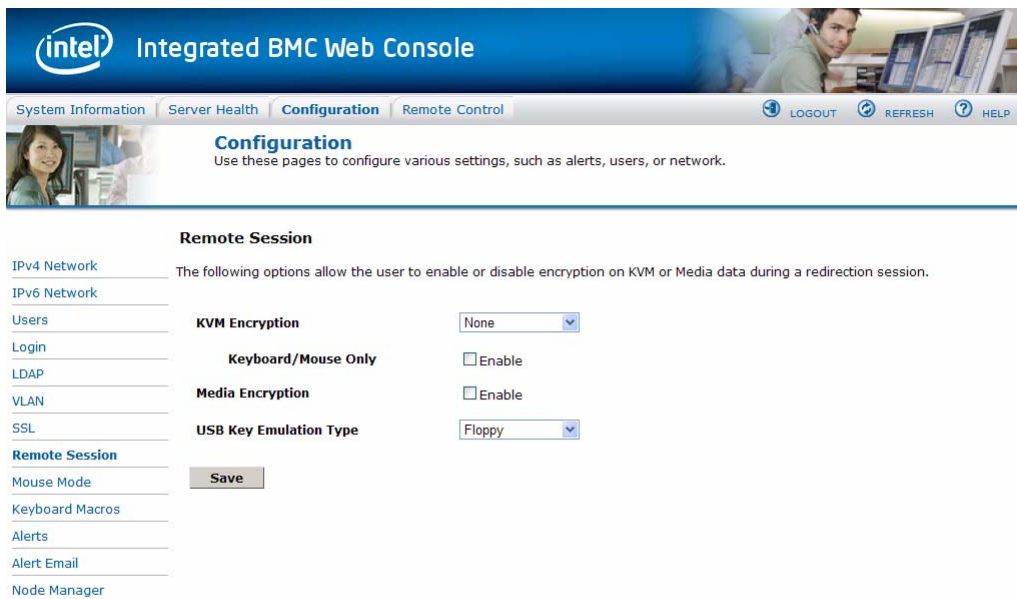

Figure 2-18 BMC Web Console – Remote Session

Mouse Mode

Mouse Mode shows you which mode the mouse is currently in, and allows you to change the mouse mode to the following options: Absolute Mode, Relative Mode, and Other Mode

Absolute Mode

Select to have the absolute position of the local mouse sent to the server. Use this mode for Windows OS and newer Red Hat linux versions (RHEL 6.x).

Relative Mode

Select Relative Mode to have the calculated relative mouse position displacement sent to the server. Use this mode for other Linux releases such as SUSE (SLES) and older versions of Red Hat (RHEL 5.x). For best results, server OS mouse acceleration/threshold settings can be reduced, or mouse calibration in JViewer performed.

Other Mode

Select Other Mode to have the calculated displacement from the local mouse in the center position, sent to the server. Under this mode ALT+C should be used to switch between Host and client mouse cursor. Use this mode for SLES 11 Linux OS installation.

The mouse mode is set by clicking the **Save** button.

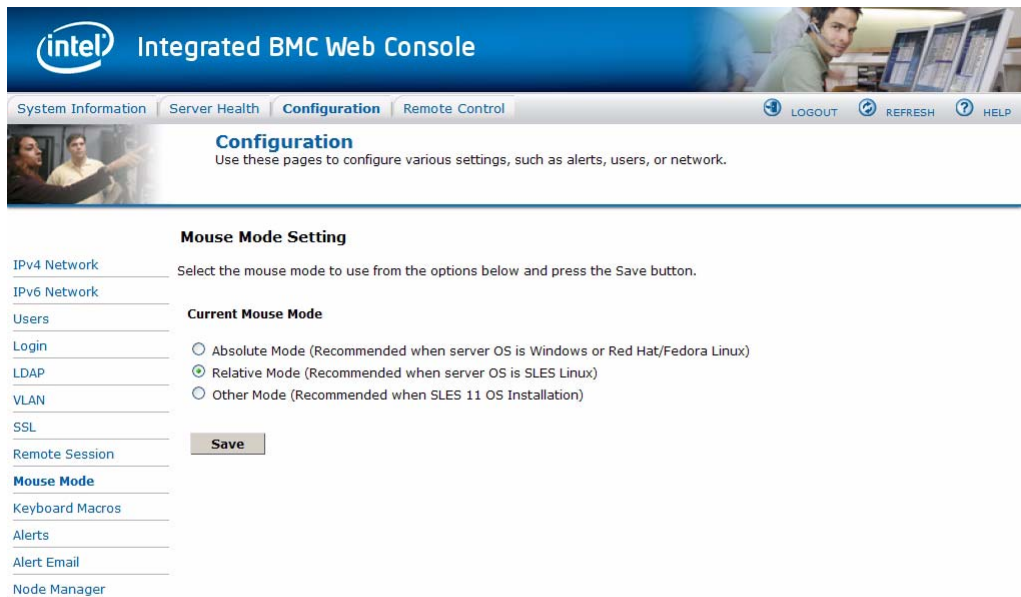

The screenshot shows the BMC Integrated Web Console interface. The top navigation bar includes 'System Information', 'Server Health', 'Configuration' (selected), and 'Remote Control'. Below the navigation bar, the 'Configuration' section is active, with a sub-header 'Configuration' and a description: 'Use these pages to configure various settings, such as alerts, users, or network.' The main content area is titled 'Mouse Mode Setting' and contains the following text: 'Select the mouse mode to use from the options below and press the Save button.' Underneath, there is a section for 'Current Mouse Mode' with three radio button options: 'Absolute Mode (Recommended when server OS is Windows or Red Hat/Fedora Linux)', 'Relative Mode (Recommended when server OS is SLES Linux)' (which is selected), and 'Other Mode (Recommended when SLES 11 OS Installation)'. A 'Save' button is located below the radio buttons. On the left side of the page, there is a vertical menu with links to various configuration sections: IPv4 Network, IPv6 Network, Users, Login, LDAP, VLAN, SSL, Remote Session, Mouse Mode (highlighted), Keyboard Macros, Alerts, Alert Email, and Node Manager.

Figure 2-19 BMC Web Console – Mouse Mode Setting

Keyboard Macros

The Keyboard Macros page is where you can view and modify keyboard macros. **Key Sequence** is the sequence of key events to playback when the macro button is pushed. **Button Name** is the optional short name to appear on the button of the Remote Console. If left blank, the key sequence string will be used as the button name. Click the **Help** button in the upper right corner (Figure 2-20), to see the supported key names (Table 2-5). In this example, two macros have been defined: Ctrl+Alt+Del and Alt+Tab (Figure 2-21).



Figure 2-20 BMC Web Console – Logout, Refresh, and Help buttons

 A screenshot of the BMC Web Console Configuration page. The top navigation bar includes 'System Information', 'Server Health', 'Configuration', and 'Remote Control'. The 'Configuration' section is active, showing a list of settings on the left: IPv4 Network, IPv6 Network, Users, Login, LDAP, VLAN, SSL, Remote Session, Mouse Mode, Keyboard Macros, Alerts, Alert Email, and Node Manager. The 'Keyboard Macros' section is expanded, displaying a table with 10 rows for defining macros. The first two rows are populated with 'Ctrl+Alt+Del' and 'Alt+Tab' respectively. A 'Save' button is located at the bottom of the table.

	Key Sequence	Button Name
#1	Ctrl+Alt+Del	Ctrl Alt Del
#2	Alt+Tab	Alt Tab
#3		
#4		
#5		
#6		
#7		
#8		
#9		
#10		

Save

Figure 2-21 BMC Web Console – Keyboard Macros

Key Sequence

When using a key sequence, keep the following definitions in mind:

- '+' between keys indicates the keys should be held down together
- '-' between keys indicates the previous keys should first be released before the new key is pressed
- '*' inserts a one second pause in the key sequence.

Caution: Video is not updated during macro execution.

Examples:

Ctrl+Alt+Del

Ctrl+B-Enter-**Enter

Ctrl+B-Enter-**-Enter

Keys

Key names are either a printable character such as “a”, “5”, “@”, etc. or else one of the non-printable keys in the table below. Names in parentheses are aliases for the same key. Numeric keypad keys are prefixed with “NP_”.

A plain '*' means a pause; use '*' for the actual '*' key. The '\' key must also be escaped as '\\'.

Table 2-5 Supported Key Names

Shift (LShift)	RShift	Ctrl (LCtrl)	RCtrl
Alt (LAlt)	RAlt (AltGr)	Win (LWin)	RWin
Enter	Esc	F1 - F12	
Bksp	Tab	CapsLk	Space
Ins	Del	Home	End
PgUp	PgDn	Context (Menu)	
Up	Left	Down	Right

Table 2-5 Supported Key Names

NumLk	NP_Div	NP_Mult	NP_Minus
NP_Plus	NP_0 - NP_9	NP_Dec	NP_Enter
PrtSc (SysRq)	ScrLk	Pause (Break)	

Note: Key sequences are sent to the target as scancodes that get interpreted by the target OS, so they will be affected by modifiers such as Numlock as well as the OS keyboard language setting.

Alerts

The Alerts page allows you to configure which system events generate Alerts and the external network destinations they should be sent to.

When one of the selected system events occurs, an alert is generated and sent to the configured destination(s). Each LAN channel can have up to two destinations.

Globally Enable Platform Event Filtering

Global control for enabling or disabling platform event filtering. When filtering is globally disabled through this setting, alerts will not be sent. This can be used to prevent sending alerts until you have fully specified your desired alerting policies.

Select Events

Select one or more system events that will trigger an Alert. Clearing all events disables Alerts. These events correspond to the IPMI preconfigured Platform Event Filters.

LAN Channel

Select which LAN Channel to configure destinations for. Each LAN Channel has its own set of up to two destinations. Alert destinations can be one of two types:

- SNMP Trap
- Email (requires Alert Email to be configured)

The **Check All** button selects all events to generate Alerts. The **Clear All** button unchecks all events so no Alerts will be generated. Click the **Save** button to save any changes made.

Send Test Alert

To test whether an alert will reach it's destination, set the LAN Channel field to the desired channel and configure at least one destination. Then click **Send Test Alerts** to send a simple test alert to the destination(s) for that Channel.

Alerts

Configure which system events generate Alerts and the external network destinations they should be sent to.

IPv4 Network

IPv6 Network

Users

Login

LDAP

VLAN

SSL

Remote Session

Mouse Mode

Keyboard Macros

Alerts

Alert Email

Node Manager

Globally Enable Platform Event Filtering: Enabled Disabled

Select the events that will trigger alerts:

- Temperature Sensor Out of Range
- System Restart
- Fan Failure
- Power Supply Failure
- BIOS: Post Error Code
- Node Manager Exception
- Watchdog Timer
- Voltage Sensor Out of Range
- Chassis Intrusion
- Memory Error
- FRB Failure
- Hard Drive Failure

Check All **Clear All**

LAN Channel to Configure: Baseboard Mgmt

Alert Destination #1:

SNMP Send SNMP Alerts to IP: 137.38.102.30

Email Send Email to: jbrewer@sgi.com

Alert Destination #2:

SNMP Send SNMP Alerts to IP: 0.0.0.0

Email Send Email to:

Save **Send Test Alerts**

Figure 2-22 BMC Web Console – Alerts

Alert Email

Alert Email Settings allows you to configure how Alerts are sent by email to an external SMTP Mailserver. Each LAN Channel has a separate configuration, selected through the drop-down

menu. The **SMTP Server IP** is the IP address of the remote SMTP Mailserver that Alert email should be sent to. The **IP Address** is made of 4 numbers separated by dots as in xxx . xxx . xxx . xxx where 'xxx' ranges from 0 to 255 and the first 'xxx' group must not be 0. The **Sender Address** is the string to be put in the FROM: field of outgoing Alert emails. **Local Hostname** is the hostname of the local machine that is generating the alert, included in the outgoing Alert email. The **Local Hostname** is a string of maximum 31 alpha-numeric characters. Spaces and special characters are not allowed.

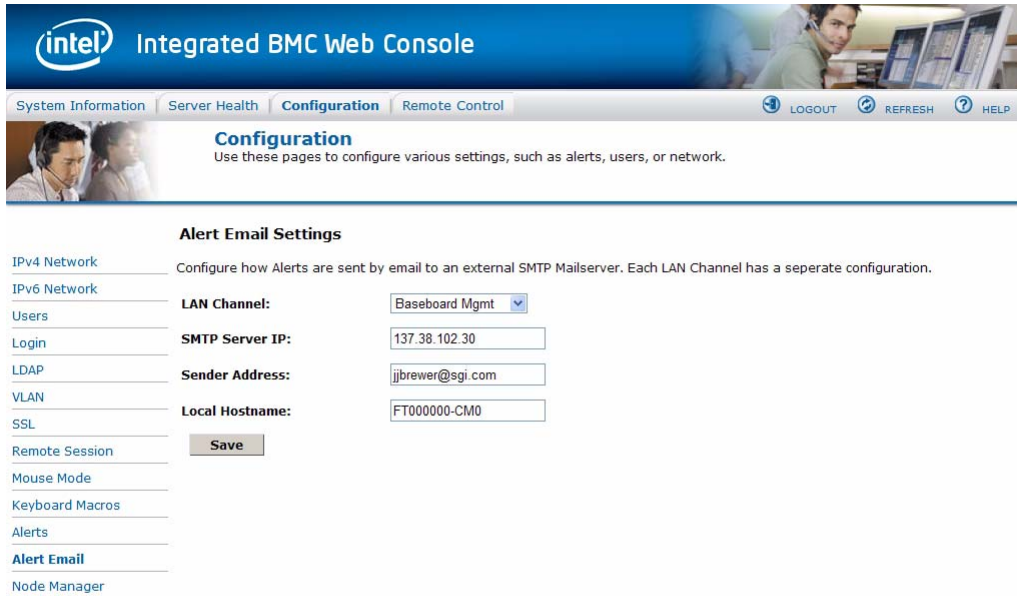

Figure 2-23 BMC Web Console – Alert Email Settings

Node Manager

Use this page to configure the system's Node Manager.

The screenshot shows the BMC Integrated Web Console interface. At the top, there is a navigation bar with the Intel logo and the text "Integrated BMC Web Console". Below this, there are tabs for "System Information", "Server Health", "Configuration", and "Remote Control". The "Configuration" tab is active. On the right side of the navigation bar, there are buttons for "LOGOUT", "REFRESH", and "HELP".

Below the navigation bar, there is a section titled "Configuration" with a subtitle: "Use these pages to configure various settings, such as alerts, users, or network." Below this, there is a sidebar with a list of configuration categories: IPv4 Network, IPv6 Network, Users, Login, LDAP, VLAN, SSL, Remote Session, Mouse Mode, Keyboard Macros, Alerts, Alert Email, and Node Manager. The "Node Manager" category is selected.

The main content area is titled "Node Manager Power Policies" and contains the text: "Use this page to set Node Manager Power Policies." Below this, there is a table with columns: Policy, Timers, Enabled, Shutdown, Alert, and Power Limit. The "Policy" column is highlighted.

Below the table, there is a section titled "Add/Edit Node Manager Policies." with the following fields and options:

- Policy Number:** A text input field.
- Enabled:** A checkbox.
- Hard Shutdown:** A checkbox.
- Log Event:** A checkbox.
- Power Limit:** A text input field followed by "(Watts)".
- Use Policy Suspend Periods:** Radio buttons for "Yes" and "No".

At the bottom of the form, there are three buttons: "Save", "Delete", and "Cancel".

Figure 2-24 BMC Web Console – Node Manager Power Policies

Node Manager Power Policies

This table lists the currently-configured policies. Selecting an item from the table will populate the editable fields in the settings section below.

Policy Number

The policy number to add/edit/delete. Valid range is 0-255.

In the policy table, policy numbers with an asterisk (*) are policies set externally using a non-platform domain. Changing parameters on these policies will not affect their triggers, trigger limits, reporting periods, correction timeouts, or aggressive CPU throttling settings.

Enabled

Check this box if the policy is to be enabled immediately.

Hard Shutdown

Check this box to enable a hard shutdown if the policy is exceeded and cannot be corrected within the correction timeout period.

Log Event

Check this box to enable the node manager to send a platform event message to the BMC when a policy is exceeded.

Power Limit

The desired platform power limit, in watts.

Use Policy Suspend Periods

If enabled, you may configure policy suspend periods. Each policy may have up to five suspend periods.

Suspend periods are repeatable by day-of-week. Start and stop times are designated in 24 hour format, in increments of 6 minutes. To specify a suspend period crossing midnight, two suspend periods must be used.

Policy Defaults

For all policies set through this web page, several default values will be applied:

- Domain: Platform - Power for the entire platform.
- Trigger: None - Always monitor after end of POST.
- Aggressive CPU Power Correction: AUTO - Use of T-states and memory throttling controlled by policy exception actions.
- Trigger Limit: None.
- Reporting Period: 10 seconds - This is a rolling average for reporting only. It will not affect the average power monitored by the node manager.

- Correction Timeout: 22.555 seconds - Maximum time for the NM to correct power before taking an exception action (i.e. shutdown or alert).

Remote Control Tab

This section of the BMC Web Console allows you to remotely monitor and control the server. Options available in the left navigation pane are **Console Redirection** for remote server management. **Server Power Control** shows the current power status, and allows power operations. Finally the **Virtual Front Panel** is a graphic display of the front panel allowing for remote front panel functionality.

Console Redirection

From the Console Redirection page, if available, you can launch the remote console KVM redirection window. The remote console requires an RMM (Remote Management Module) add-in card, otherwise the launch button is greyed-out (Figure 2-25).



Figure 2-25 BMC Web Console – Console Redirection (greyed-out)

Clicking on **Launch Console** (Figure 2-26) will prompt for download of JViewer.jnlp file. When the file is downloaded and launched, the Java redirection window will be displayed.

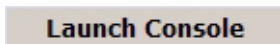

Figure 2-26 BMC Web Console – Launch Console button (available)

Note: Java Run-Time Environment (JRE, version 6 update 10 or later) must be installed on client prior to launch of JNLP file.

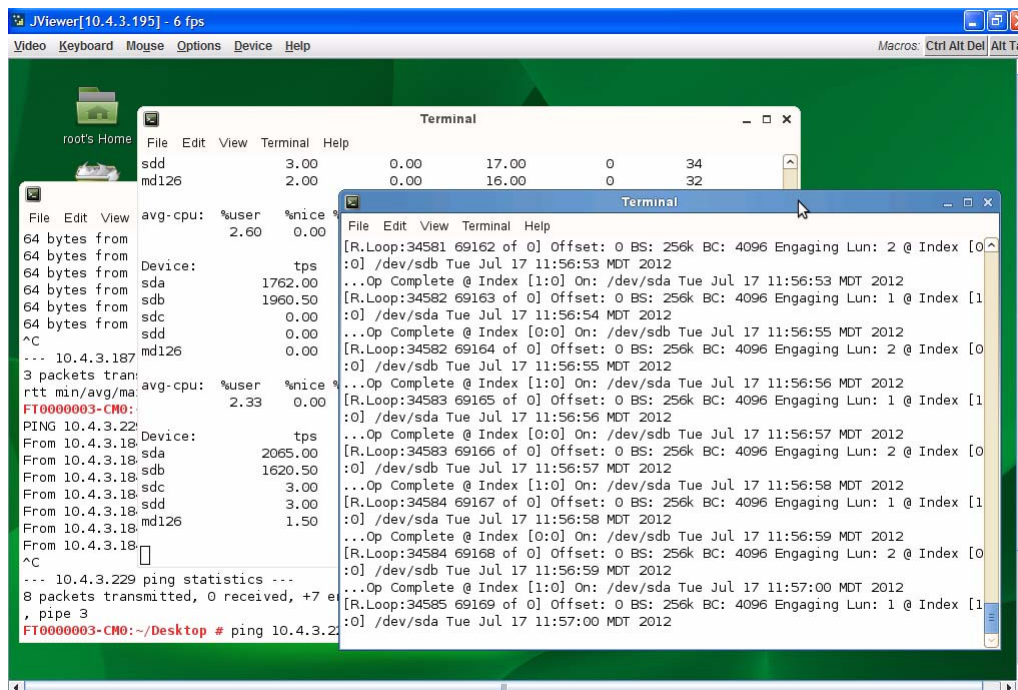

Figure 2-27 Remote Console – Java redirection window

Server Power Control

This page shows the power status of the server and the following power control operations can be performed:

Table 2-6 Server Power Control Actions

Option	Details
Reset Server	Selecting this option will hard reset the host without powering off.
Force-enter BIOS Setup	Check this option to enter into the BIOS setup after resetting the server.
Power Off Server	Selecting this option will immediately power off the host.

Table 2-6 Server Power Control Actions

Option	Details
Graceful Shutdown	Selecting this option will soft power off the host.
Power On Server	Selecting this option will power on the host.
Power Cycle Server	Selecting this option will immediately power off the host, then power it back on after one second.

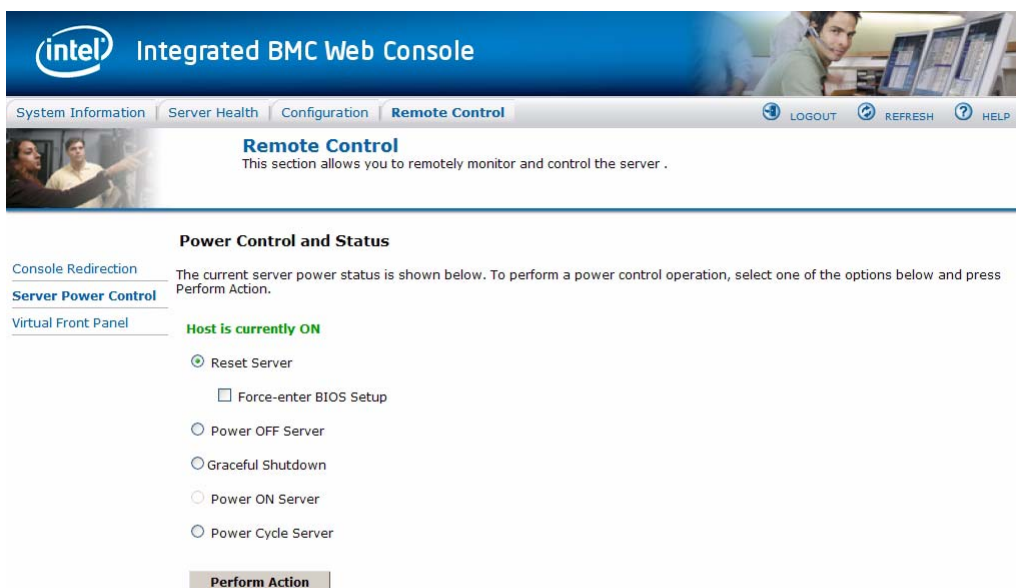
**Figure 2-28** BMC Web Console – Power Control and Status

All power control actions are done through the BMC and are immediate actions. It is suggested to gracefully shut down the operating system via the KVM interface or other interface before initiating power actions.

The Virtual Front Panel is a graphic representation of the front panel, providing remote functionality virtually.

Table 2-7 System Information Details

Button	Details
Power Button	Power button is used to Power ON or Power OFF
Reset Button	Reset Button is used to reset the server while system is ON
Chassis ID Button	When Chassis ID button is pressed then the chassis ID LED, on the front and rear of the unit are lit (solid blue). If the button is pressed again the chassis ID LED turns off.
NMI Button	At present, NMI button is disabled.
Status LED	Status LED will reflect the system status and will automatically sync with BMC every 60 seconds. If any abnormality occurs in system, then status LED will change accordingly. Thermal fault means <i>fault</i> occurred in one of Thermal sensors present in BMC. Fan fault means <i>fault</i> occurred in one of the system fans. System fault means a <i>fault</i> occurred because of system errors. Power fault means <i>fault</i> occurred in one of Power sensors Here, <i>fault</i> means a sensor value crossed upper-non-critical, or upper-critical value, or lower-non-critical value, or lower-critical value.

Table 2-7 System Information Details

Button	Details
Power LED	Power LED shows system power status. If LED is green then System is ON. If LED is grey then System is OFF.
Chassis ID LED	The Chassis ID LED will be lit blue when the Chassis ID LED button is pushed. This is the same as the Locator LED on the physical control panel (Table 2-1). When the Locator button is pushed again, the LED will be lit. There is a corresponding LED on the back of the server that will be lit blue as well. This function can be done physically through the Control Panel (Figure 2-1).

System Software

Overview

This chapter contains information on each of the software sets necessary for zoning MIS Servers and JBODs, organized in four sections: “Linux Zoning Tools” on page 68, “Windows Zoning Tools” on page 88, “CLI Zoning Tool” on page 109, and “Disk RAID Support” on page 122.

Zoning is required when multiple SAS connections are operational, in order to stop drives from being affected by other non-owner SAS controllers (HBAs). Zoning allows the various SAS connections to be accessible only to the drives that they own. Essentially, zoning allows an administrator to control who can see what. When no zoning is enabled, all the SAS connections can see all of the drives. For dual-ported SAS drives, **both** ports will be exposed, so the drives will show up **twice**. This situation will cause conflict between the HBAs.

Zoning can be either hard or soft. In hard zoning, each device is assigned to a particular zone, and this assignment does not change. In soft zoning, device assignments can be changed by the network administrator to accommodate variations in the demands on different servers in the network. T10 or PHY-based Zoning may be implemented on the MIS Server. For the MIS JBOD, only PHY-based Zoning is supported at this time.

Zones for Linux and Windows features a GUI for ease-of-use, but is limited to 72 drives, requires an LSI MegaRAID card, and cannot zone JBODs at this time (future releases will). The CLI Zoning Tool is command line only, but is able to zone any number of JBODs or MIS servers.

There are two main tools for zoning, the SGI Zones application and the SGI CLI Zoning Tool. Both zoning tools require the presence of other programs in order to operate. The Zones application offers a GUI interface, but is not able to zone JBODs at this time (future releases will support zoning JBODs). The CLI Zoning Tool can zone JBODs, but is a command-line only application.

Important: The Zones program is run on the server you wish to zone. JBODs are zoned through the hardware using the CLI Zoning tool installed on a server or laptop and using an Ethernet crossover cable to connect a server/laptop running either a Windows or a Linux operating system and the CLI Zoning application software.

Section Guide

This Guide is organized into four sections, “Linux Zoning Tools” on page 68, “Windows Zoning Tools” on page 88, “CLI Zoning Tool” on page 109, and “Disk RAID Support” on page 122. Inside the first three sections you will find instructions on downloading and installing the software needed, and the steps to prepare for, and zone MIS Platforms. The final section contains information on the different RAID configurations available, advantages and disadvantages of each configuration, as well as best practices.

Within the first section, “Linux Zoning Tools”, “Installing Linux Software” on page 68 gives instructions for downloading and installing the programs required to run the Linux-based zoning tools. The GUI software programs used are “MegaRAID Storage Manager for Linux”, “MegaCli64 for Linux”, and “Zones for Linux”. This section also includes information in downloading the command-line-only “CLI Zoning Tool for Linux”. Instructions for zoning using the Linux tools are given:

- “Verify Drives Seen” on page 71
- “Verify Drives Seen” on page 71
- “Installing a Drive through Zones for Linux” on page 74
- “Creating the Drive Groups in MegaRAID for Linux” on page 77
- “Formatting the Drives using YaST2 in Linux” on page 79
- “Removing a Drive in Zones for Linux” on page 83

“Additional Features in Zones for Linux” on page 85 details the extra features available in Zones for Linux including (from page 24):

- “Loading .csv Configuration Files in Linux”
- “Save a Configuration to .csv file in Linux”

Information on using the CLI Zoning Tool can be found in “CLI Zoning Tool” on page 109.

The second section, “Windows Zoning Tools”, contains “Installing Windows Software” on page 88. Here are instructions for downloading and installing the programs required to run the Windows-based zoning tools. The GUI software programs used are “MegaRAID Storage Manager for Windows”, “MegaCli64 for Windows”, “Zones for Windows”, “Python for Windows”. This section also contains information on downloading the “CLI Zoning Tool for Windows” on page 91. Instructions on using the Windows GUI are given:

- “Verify Drives Seen in Windows” on page 92
- “Verify Drives Seen in Windows” on page 92
- “Installing a Drive in Zones for Windows” on page 95
- “Creating the Drive Groups in MegaRAID for Windows” on page 98
- “Formatting the Drives in Windows Server Manager” on page 100
- “Removing a Drive in Zones for Windows” on page 106

“Additional Features in Zones for Windows” on page 107 details “Loading .csv Configuration Files in Zones for Windows” on page 107, “Adapter Assignment Synchronization in Zones for Windows” on page 108, and “Save a Configuration to .csv file in Zones for Windows” on page 109.

The third section details out the “CLI Zoning Tool,” the command-line-only tool that is currently the only tool that can zone JBODs, as well as MIS Servers. The CLI Zoning Tool requires the presence of Python 2.6 or 2.7 to be present in order to run. Python is standard on most Linux-based machines, and will need to be installed for Windows-based machines for the CLI Zoning tool to run. (See “Python for Windows,” on page 91). “Preparing to Zone using the CLI Zoning Tool,” on page 110 gives instruction on what is necessary before “Zoning Using CLI Zoning Tool,” on page 117 and “Editing the .csv File for the CLI Zoning Tool,” on page 119.

Finally, “Disk RAID Support” on page 122 explains the different RAID arrays available and the benefits and drawbacks of each. There are special considerations in creating RAID arrays for use on StorBricks, that is, there are RAID configurations, namely 6+2 and 7+2, that ensures there is no single point of failure on the StorBricks within the MIS system. “RAID Configuration Notes” on page 129 details how to manage those concerns.

Linux Zoning Tools

The following instructions are for Linux-based MIS Servers, and for Linux-based machines installing the CLI Zoning Tool. (Operation of the CLI Zoning Tool remains the same across platforms. See “CLI Zoning Tool” on page 109 for more information.)

Installing Linux Software

There are three programs necessary for SGI Zones for Linux management of MIS systems. These programs give operational control over the hardware and its performance, including zoning of the drives. They are MegaRAID Storage Manager, MegaCli64, and Zones for Linux. To run the CLI Zoning Tool on a Linux machine, only one program is necessary (the CLI Zoning Tool itself).

MegaRAID Storage Manager for Linux

Note: MegaRAID Storage Manager is not necessary for zoning using the CLI Zoning Tool.

The MegaRAID Storage Manager is used to prepare the drives for zoning using the Zones tool, and creating the drive groups after zoning using the Zones tool.

1. Go to <http://lsi.com> and search for MegaRAID Storage Manager.
2. Select and accept the latest Linux version for download and save the .tar file.
3. Change directory to where you have saved your .tar file (e.g., # `cd /usr`)
4. Unzip the .tar file, # `tar -xf <filename.tar>` (e.g.,
`tar -xf MSM_linux_x64_installer-12.01.03-00.tar`)
5. Once the folder has unzipped properly, a new folder will appear called `disk`.
6. Change your directory into the `disk` folder (i.e., # `cd /usr/disk`)
7. Install the Dependencies, (i.e., # `./install.csh`)
8. Install the MegaRAID Storage Manager rpm file, # `rpm -ivh`
`<MegaRAID_Storage_Manager_currentversion.rpm>` (e.g.,
`rpm -ivh MegaRAID_Storage_Manager-12.01.03-00.noarch.rpm`)
9. Change to `/usr/local` directory, where MegaRAID Storage Manager will appear (i.e., # `cd /usr/local/MegaRAID\ Storage\ Manager/`)

10. Issue `./startupui.sh` command to start MegaRAID Storage Manager GUI (i.e.,
`./startupui.sh`).

MegaRAID Storage Manager GUI for Linux will appear.

MegaCli64 for Linux

MegaCli64 is a program required for the Zones tool to match the StorBrick to the adapters. It runs in the background underneath Zones.

1. Go to <http://lsi.com> and search for **MegaCli64**.
2. Select and accept the latest Linux version for download.
3. Once downloaded, unzip the folder (e.g., `#tar -xf <tarfilename.tar>`)
4. Install MegaCli rpm file (e.g., `#rpm -ivh <rpmfilename.rpm>`)

Zones for Linux

Zones is proprietary SGI software, used to zone drives on the MIS Server Platform (and eventually MIS JBOD units as well). To install the software complete the following instructions.

1. Go to <http://support.sgi.com>
2. Download the latest Linux version of Zones.
3. Unzip `Zones.tar` (e.g., `# tar -xf Zones.tar`). A Zones folder will appear.
4. Copy the Zones folder into the `/opt` directory, thus creating the `/opt/Zones` directory

Warning: *Zones must be installed in the `/opt/Zones/` directory or it will not work.*

5. Change directory into the new Zones folder (e.g., `# cd /opt/Zones`)

Run the Zones program by typing `# python GUI.py`.

Note: On first use, the Zones program will ask you to enter the paths to MegaCli64 (Figure 3-1). The default path for MegaCli64 is `/opt/MegaRAID/MegaCli`. These paths can be changed at any time by going to menu option **Setup > Tools**.

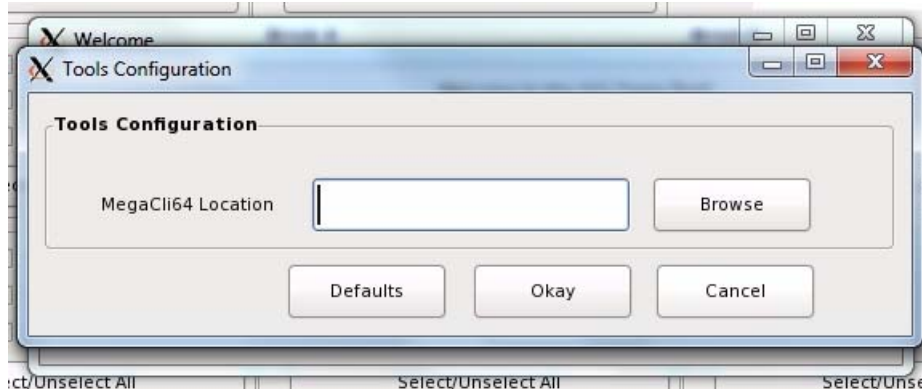

Figure 3-1 Zones – First-use path configuration

If the path is improperly set, an error message will appear. The following error message means that the path set is for a folder that does not contain MegaCLI64 (Figure 3-2).

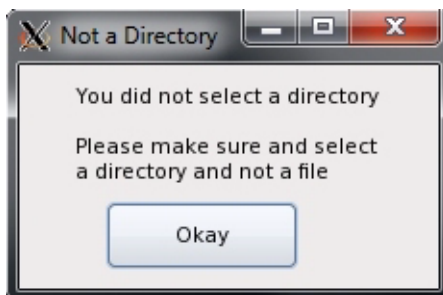

Figure 3-2 Zones – Error message: Improper path

CLI Zoning Tool for Linux

The CLI Zoning Tool is proprietary SGI software, used to zone drives on the MIS Server Platform and MIS JBOD units, and is the only tool that can zone JBODs at this time (future releases of Zones will support zoning JBODs). To install the software:

1. Create a directory for the application: `mkdir /opt/ShackCLI`
2. Go to <http://support.sgi.com>
3. Download the latest version of **ShackCLI_release_xxx.zip** into the above directory
4. Extract the files: `unzip ShackCLI_release_xxx.zip`

To run the CLI Zoning Tool, follow the instructions given in “CLI Zoning Tool” on page 109.

Verify Drives Seen

In Linux systems, open Partitioner and verify the only disks the system sees are system drives, labeled `/opt/` (Figure 3-23 on page 82).

Note: Unconfiguring drives removes them from the system.

Linux Zones Tool

The SGI Zones tool is a proprietary software program that uses a GUI interface to zone the drives in the MIS Server. Future releases will support zoning JBODs as well.

Open the Zones tool. In Linux, this is done by changing to the `/opt/Zones` folder and typing `# python GUI.py`.



Figure 3-3 Linux Zones Welcome

Note: When Zones for Linux opens, leave the terminal window, from which you launched Zones, open. This window must be left open or the program shuts down. It will be used later in downloading session information to the StorBricks.

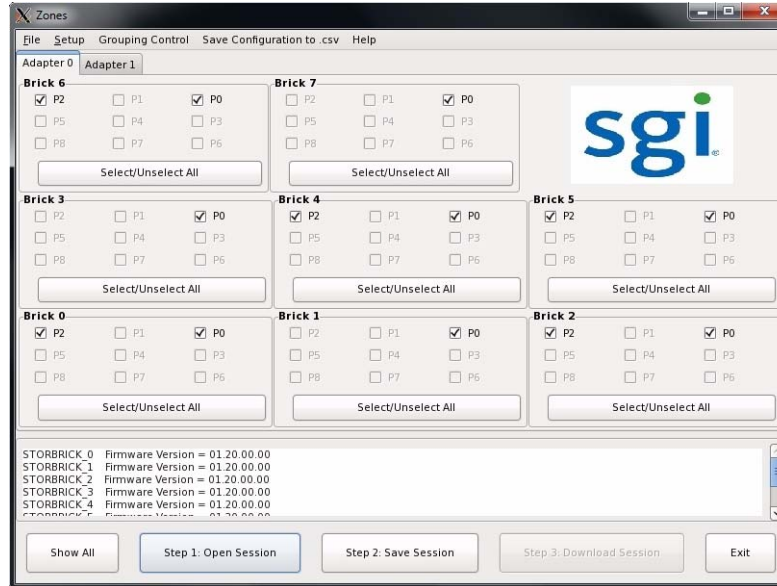

Figure 3-4 Zones User Interface

To begin zoning, click **Open Session** (Figure 3-5). This queries each expander for the information contained in the expander .bin file.

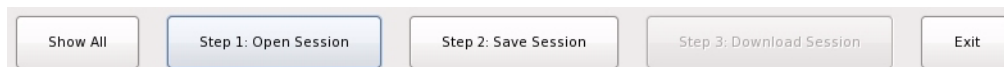

Figure 3-5 Zones – Show All, Open Session, Save Session, Download Session, and Exit buttons

Click **Create New Session** (Figure 3-6).



Figure 3-6 Zones – Opening a Session

The Zones program will ask you for a **Session Alias** (Figure 3-7). This alias will be added to a time stamp to create folder for that session’s files: `YYMMDD_HHMMSS_alias`.

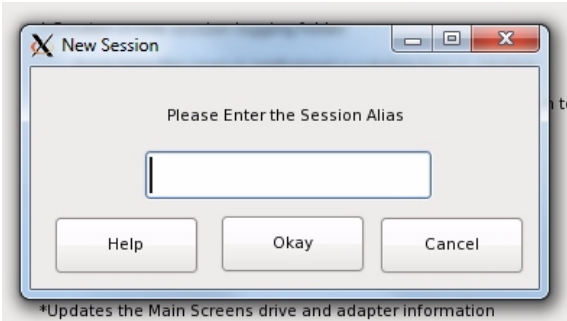

Figure 3-7 Zones – Enter Session Alias

Enter an alias and click **Okay**.

Note: Aliases have a 64 character limit, and may not contain spaces or non-alpha-numeric characters; these will be replaced with an underscore if used and a warning message will appear (Figure 3-8).

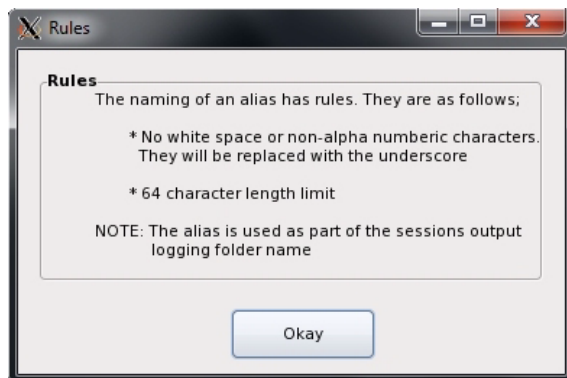

Figure 3-8 Zones – Alias Help Warning Message

In Zones for Linux, `.bin` files are automatically named `#.bin` where `#` is the number of the StorBrick in question. After the `.bin` file has been fetched, each file is converted into an XML file, named using the same convention, with the file extension `.xml` (e.g., `#.xml`).

Upon opening, Zones for Linux will show a blank template for zoning. It will not show any zoning that may be currently implemented. It does not show drives that are presently installed or zones that are currently active. Each adapter has its own tab above the StorBrick layouts (Figure 3-9). The number of Adapter tabs will directly correspond to the number of Adapters Zones sees in the system.

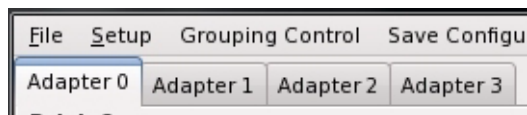

Figure 3-9 Zones – Adapter tabs

Installing a Drive through Zones for Linux

After creating a new session, click the **Show All** button. This enables all boxes on all adapters (Figure 3-10), even if there are no drives physically present. This is so a drive can be zoned to the system that isn't seen by the system yet.

Note: If a drive is zoned to more than one adapter, a warning message (Figure 3-11) will appear. In Windows, this warning tells which adapter that drive is already zoned to, and a message asking if you would like to continue. In Linux, there is just a warning message asking if you would like to continue. It is possible to zone one drive to two adapters. This is allowed, but not suggested, as it can cause data collisions.

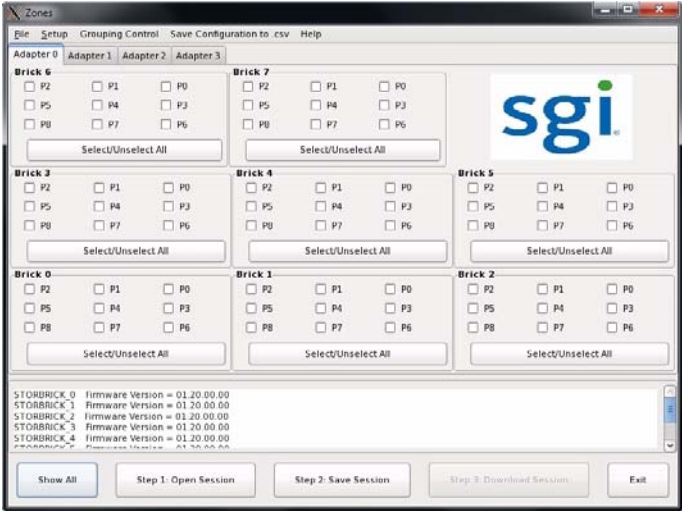

Figure 3-10 Zones – Show All

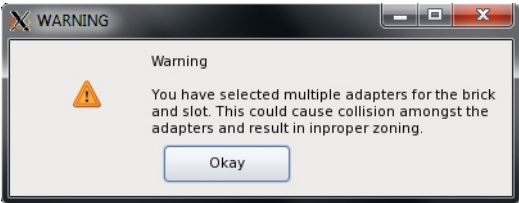

Figure 3-11 Zones – Adapter Assignment Warning Message

Check the boxes for the drives you want to zone (Figure 3-12) according to the configuration of your liking. Click **Save Session**. This takes the screen configuration and saves it to an .xml file that is then converted into a .bin file.

Note: The **Save Session** button will become enabled whenever a change has been made in the Zones configuration.

In Linux, the name of the new `.bin` file is `STORBRICK_#.bin` where the only new element to the file name is the `STORBRICK_`. In Windows, the name of the new `.bin` file is `sbm#_****.bin` where the only new element to the file name is the `n` after `sb`.

Important: Each time the **Save Session** button is pushed, these files are overwritten. There is no way to retrieve previously saved information.

Click the **Download** button. Once complete, this function pushes the files back into the expanders. Select which StorBricks to push the files to, and click **Okay** to push the files.

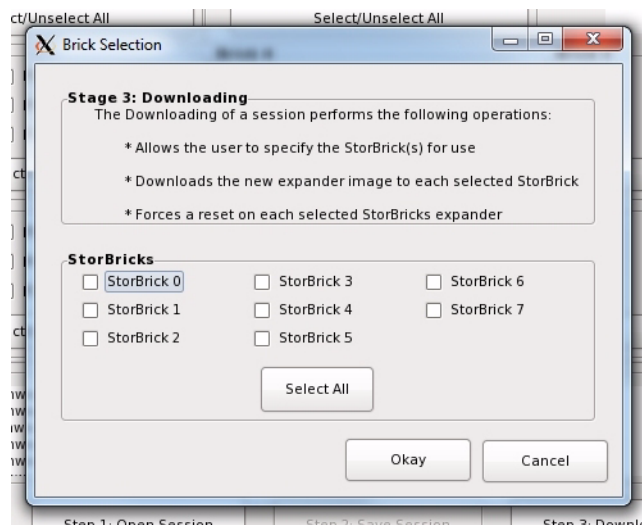

Figure 3-12 Zones – Select StorBricks for download

In Linux, downloads are confirmed through the terminal window, which show a pane where you can verify Image Validation and Checksum have passed, and then download files by entering `Y` (see Figure 3-27 on page 85).

Warning: If **Y** is chosen and the **Image Validation and Checksum** have not passed, unknown results will occur, including losing expander information, requiring a field technician to service the machine.

Power cycle the machine.

Creating the Drive Groups in MegaRAID for Linux

Right-click on the expander and select **Create a Virtual Drive** (Figure 3-13).

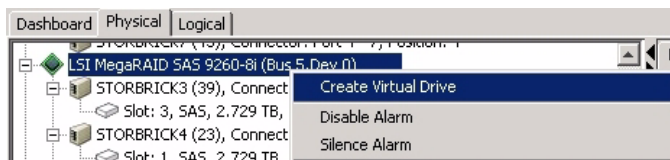

Figure 3-13 MegaRAID – Create a Virtual Drive

A screen will pop up asking you to choose **Simple** or **Advanced** (Figure 3-14). In Simple mode, the drives are chosen for you. In Advanced mode, you get to choose the drives, and are given additional selections in RAID levels, allowing for spanned (00, 10, 50, 60) drives.

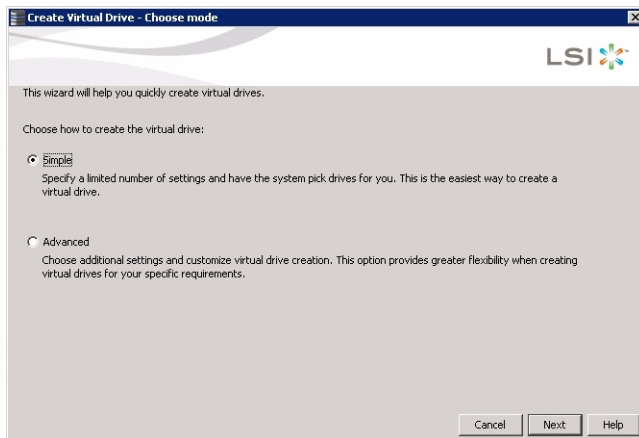

Figure 3-14 MegaRAID – Create Virtual Drive mode

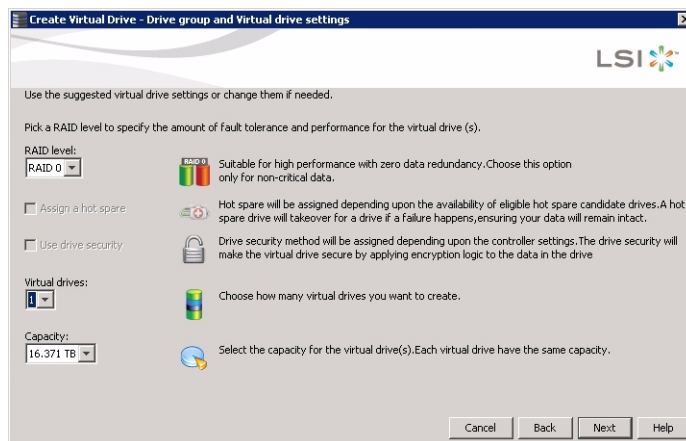

Figure 3-15 Create Virtual Drive – Drive Group Settings

Choose **Write Back BBU** (battery back-up unit). This mode is the safest and the fastest, and will automatically switch from caching mode to write-straight-to-disk whenever battery power has reached low. **Write Through** writes straight to disk. **Write Back** is a cached data flow.

Warning: If you select **Write Back** and power to the system is lost, data is lost.

Click **Next**, and a summary screen verifying settings will appear (Figure 3-16).

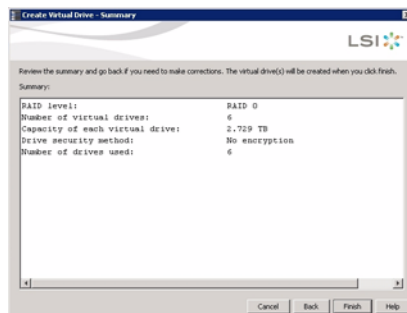

Figure 3-16 Create Virtual Drive – Summary

If the settings are correct, click **Finish**, and click **Ok**.

Formatting the Drives using YaST2 in Linux

Drives may be formatted using YaST2 Partitioner. In Linux, the folders that the drives will be mounted to need to be created first. Each mount will need a new folder. Some Linux customers will have the ability to issue the YaST2 command, bringing up a GUI to partition drives. Otherwise, drives are formatted and mounted using command line.

1. Issue YaST2 command (i.e., # `yast2`) to launch the YaST 2 Server Manager GUI (Figure 3-17).

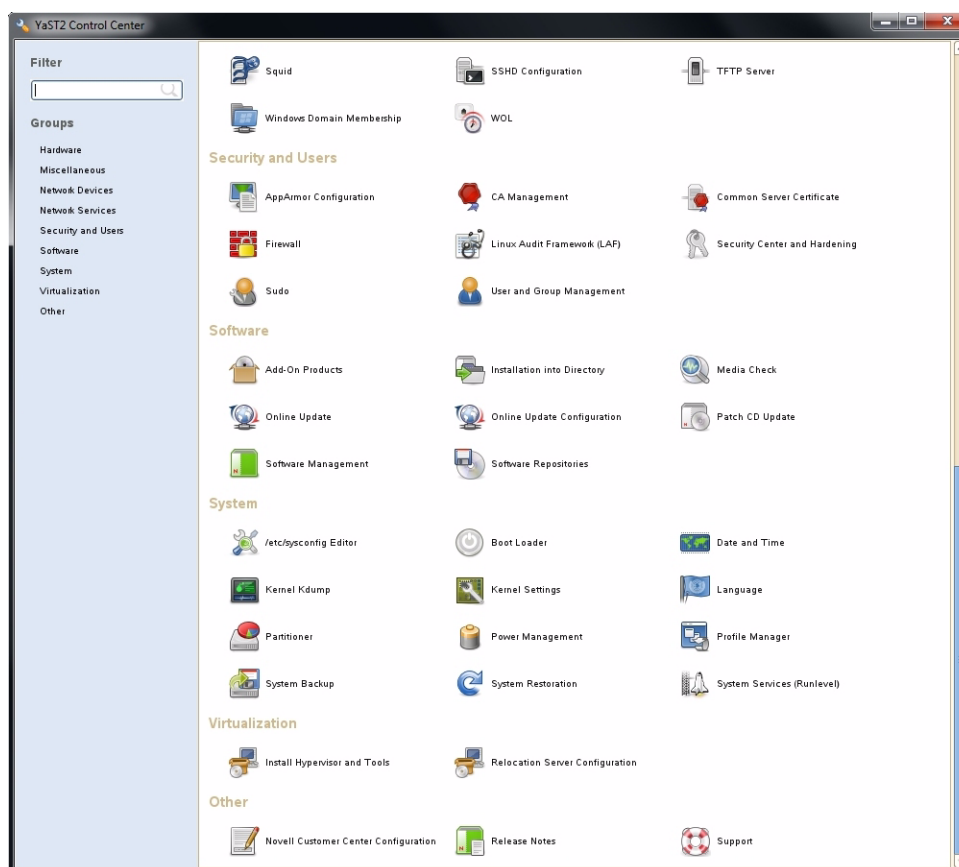

Figure 3-17 Yast2 Server Manager GUI

2. Double-click **Partitioner** to launch.

3. A warning message will appear (Figure 3-18). Click **Yes**.



Figure 3-18 YaST2 – Warning Message

4. Verify that all of your disks have appeared under **Hard Disks** (Figure 3-19).

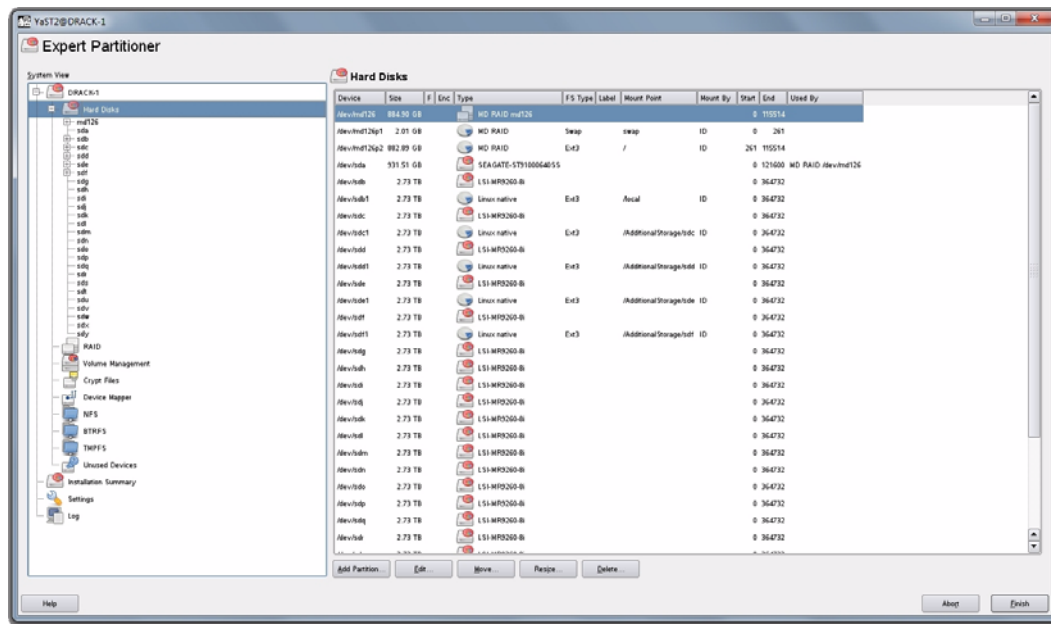

Figure 3-19 YaST2 – Drives have appeared

5. Under **Hard Disks**, select the disk you would like to partition and click **Add** at the bottom of the screen (Figure 3-20).



Figure 3-20 YaST2 – Add button

6. Select the partition size (Figure 3-21) and click **Next**.

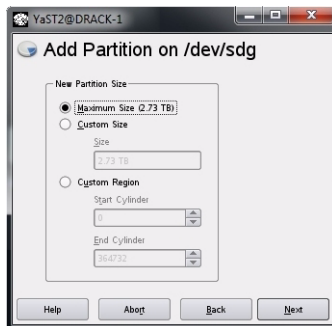

Figure 3-21 YaST2 – Select Partition Size

7. Format the partition using `ext3`, mount the disk to your desired folder, and click **Finish** (Figure 3-22).

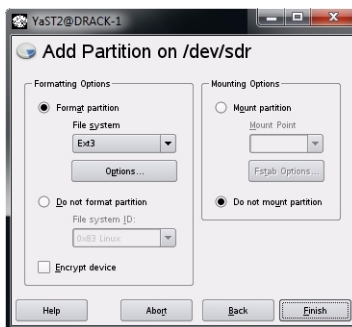

Figure 3-22 YaST2 – Format & Mount the Drive

8. Verify the partition shows up (Figure 3-23) and click **Next**.

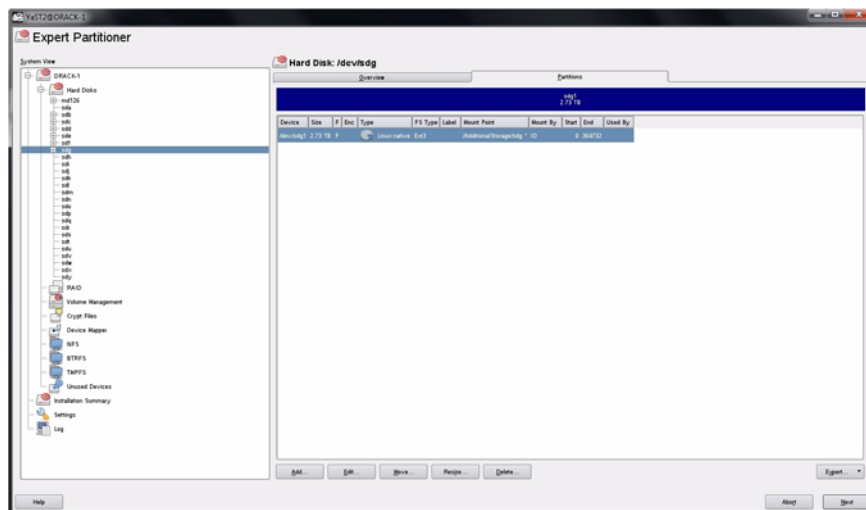

Figure 3-23 YaST2 – Check for Partition

9. Click **Finish** (Figure 3-24).

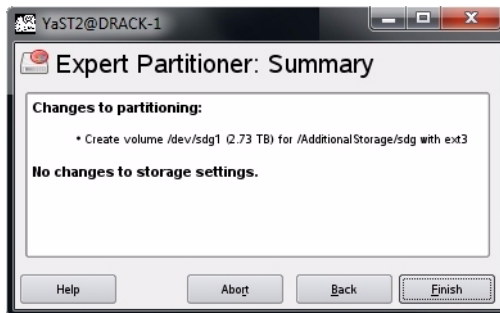

Figure 3-24 YaST – Click Finish

It may take several minutes for the system to mount the disk.

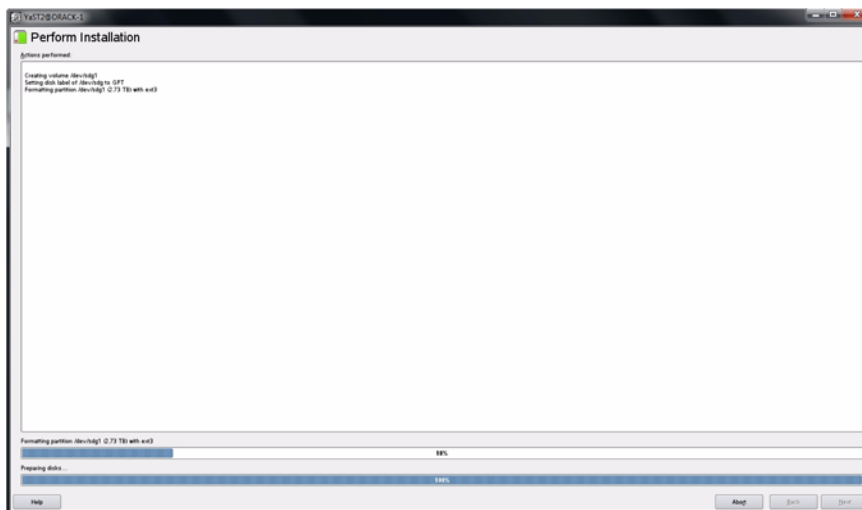

Figure 3-25 YaST2 – Disk Mounting (in process)

Once the disk is mounted (Figure 3-25), the system will return you to the beginning YaST2 GUI.

Removing a Drive in Zones for Linux

From the Zones user interface (Figure 3-4 on page 72), you can unzone a drive from an adapter by unchecking boxes. Once the drives are unzoned, click the **Save Session** button (Figure 3-5 on page 72). This action takes the configuration shown on the screen, saves it to an `.xml` file, that is then converted into a `.bin` file, and stores it on the expander card.

Note: The **Save Session** button will become enabled whenever a change has been made in the Zones user interface.

In Linux, the name of the new `.bin` file is `STORBRICK_#.bin` where the only new element to the file name is the `STORBRICK_`. In Windows, the name of the new `.bin` file is `sbn#_****.bin` where the only new element to the file name is the `n` after `sb`.

Important: Each time the **Save Session** button is pushed, these files are overwritten. There is no way to retrieve previously saved information.

Click the **Download Session** button. A window will appear asking you which StorBricks you would like to download to, by selecting checkboxes next to the corresponding StorBrick (Figure 3-26), or choosing **Select All**. Click **Okay** when satisfied.

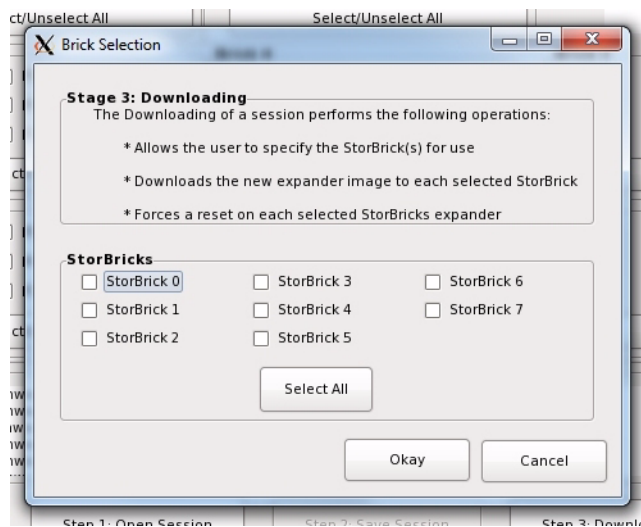

Figure 3-26 Zones – Downloading setting to StorBrick(s)

After clicking **Okay**, go to the terminal window that was started automatically upon launching the Zones for Linux tool (“Linux Zones Tool Note,” on page 71). In this window, check to see that the values for `Image Validation` and `Checksum` are both listed as `Passed`. If they are, a **Y** will be the default option in answer to the question: `Are you sure to download file to expander? [sic]`. You will have to answer **Y** for each StorBrick you wish to download files to (Figure 3-27).

If either `Image Validation` or `Checksum` have failed, the default answer will be **N**, which is what you should choose if they have failed. If **N** is chosen, the information is not sent to the StorBrick, and that StorBrick is skipped. (Reasons for `Image Validation` or `Checksum` not passing could be—for example—an invalid template file or conversion from `.xml` to `.bin` failed.)

Warning: If **Y** is chosen and the `Image Validation` and `Checksum` have not passed, unknown results will occur, including losing expander information, requiring a field technician to service the machine.

```

root@shacktest1:/opt/Zones
timestamp = 2012_09_05_03_18
*****
Xutil
LSI SAS Expander Utility
Version: 10.0.0.0
Copyright (c) 2011 LSI Corporation. All rights reserved.
*****
Initializing Interface.
Expander: STORBRICK (SAS2x36)

Image Validation: Passed
Checksum: Passed
Current Version: 02.0a
Replacement Version: 02.0a

Pre-Validation of image is successful.
Are you sure to download file to expander?(y/n):y

```

Figure 3-27 Zones – Are you sure to download files to expander?

If Image Validation or Checksum are showing as Failed, choose **N** to answer the question: Are you sure to download file to expander? [sic] Once all downloads have either been answered **Y** or **N**, if **any** of the downloads were answered **N**, you *must close and re-open* the Zones program.

Warning: If there are ANY failed downloads, **DO NOT REBOOT OR POWER CYCLE THE MACHINE** under ANY circumstance.

If the problem of failed Image Validation or Checksum continues, contact SGI Technical Support (“Product Support” on page xxv of the *MIS User Guide*). Otherwise, once all the downloads have passed and been answered **Y**, power-cycle the machine for these changes to take effect.

Additional Features in Zones for Linux

The Zones application also includes tools for “Loading .csv Configuration Files in Linux” and “Save a Configuration to .csv file in Linux”. Their instructions are provided here.

Loading .csv Configuration Files in Linux

One option for zoning is editing zoning values in a .csv file, created through spreadsheet programs that support .csv file extension (e.g., Microsoft Excel).

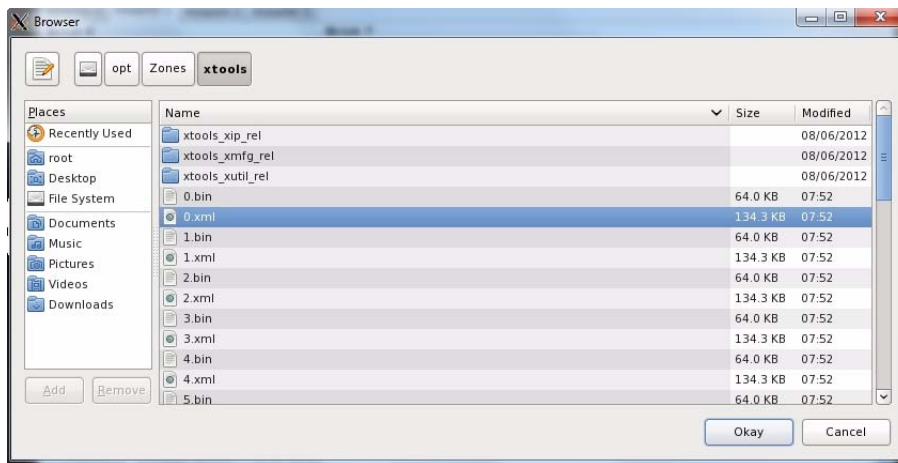

Figure 3-28 Zones – Select CSV File (Linux)

To begin in either version, select **Open Session** (Figure 3-6 on page 73). Select **Load CSV File**. Enter an alias for the session (Figure 3-7 on page 73) and click **Okay**. A **File Location** pane will open (Figure 3-28). Select the .csv file you wish to upload, and click **Okay**. The configuration entered in the .csv file will show in the Zones GUI (Figure 3-4), with the exception that the zoning may need to be synchronized with the hardware, explained below.

Save a Configuration to .csv file in Linux

The Zones tool also allows you to save configurations created in the GUI as a .csv file. In the top menu bar, there is the option to **Save Configuration to csv** (Figure 3-29).

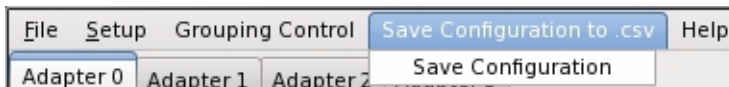

Figure 3-29 Zones – Save Configuration to .csv

Click that menu option, and in the drop-down menu that appears, click **Save Configuration** (Figure 3-29). A **Save CSV** pop-up window will appear (Figure 3-30), asking you to enter a **Directory** (file location) and **File Name** (name for the .csv file).

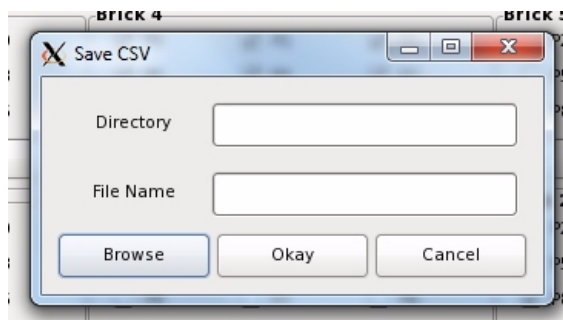

Figure 3-30 Zones – Save CSV pop-up

There is also the option to browse to a directory using the **Browse** button. This will open a navigation pane where you can select the directory (Figure 3-31).

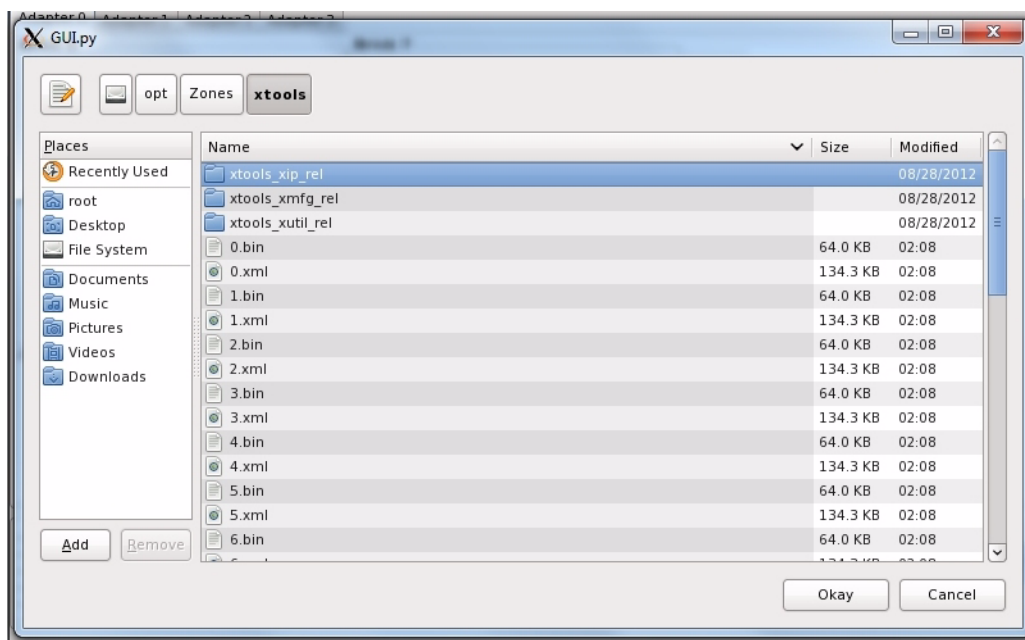

Figure 3-31 Zones – Select Directory navigation pane

If a directory is not chosen, or an improper directory choice is made (choosing a program instead of a file, etc.) an error message will appear (Figure 3-32).



Figure 3-32 Zones – Error: Improper Directory Selection

Once satisfied, click **Okay** (Figure 3-32). The values set in the GUI will be output as a `.csv` file in the directory selected earlier.

Windows Zoning Tools

The following instructions are for Windows-based MIS Servers, and for Windows-based machines installing the CLI Zoning Tool. (Operation of the CLI Zoning Tool remains the same across platforms. See “CLI Zoning Tool” on page 109 for more information.)

Installing Windows Software

There are four programs necessary for Windows management of MIS systems. These programs give operational control over the hardware and its performance, including zoning of the drives. They are MegaRAID Storage Manager, MegaCli64, Zones, and Python. To run the CLI Zoning Tool on a Windows machine, the machine must have Python installed as well as the CLI Zoning Tool itself.

MegaRAID Storage Manager for Windows

Note: MegaRAID Storage Manager is not necessary for zoning using the CLI Zoning Tool.

The MegaRAID Storage Manager is used to prepare the drives for zoning, and to create the drive groups after zoning.

1. Go to <http://lsi.com> and search for MegaRAID Storage Manager.
2. Select and accept the latest Windows version for download.

3. Download and install.

MegaRAID Storage Manager GUI for Windows will appear.

MegaCli64 for Windows

MegaCli64 is a program required for the Zones tool to match the StorBrick to the adapters. It runs in the background underneath Zones.

1. Go to <http://lsi.com> and search for **MegaCli64**.
2. Select and accept the latest Windows version for download.
3. Download and install.

Zones for Windows

Zones is proprietary SGI software, used to zone drives on the MIS Server Platform.

1. Go to <http://support.sgi.com>
2. Download the latest Windows version of Zones.
3. Unzip the `Zones.zip` file. Make sure that destination the files will be extracted to is `c:\`. A **Zones** folder will be created automatically, generating the directory `c:\Zones\`

To run Zones, go to **Start > Run**, and type in `c:\Zones\Zones.exe`, and click **Okay**.

Note: On first use, the Zones will ask you to enter the paths to MegaCli64 (Figure 3-33). The default path for MegaCli64 is `C:\Program Files (x86)\MegaRAID Storage Manager\MegaCLI\MegaCli64` and `C:\Zones\XTOOLS` is the default path for XTOOLS. These paths can be changed at any time by going to menu option **Setup > Tools**.

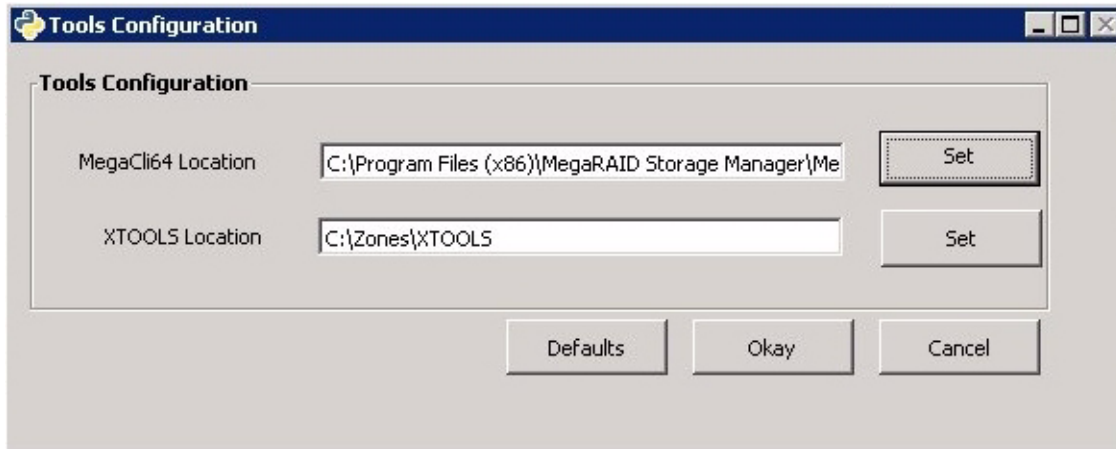

Figure 3-33 Zones – First-use path configuration (Windows)

If the path is improperly set, an error message will appear. The following error messages means that the path set is for a folder that does not contain MegaCLI64, and Zones will not run properly (or the system may crash).

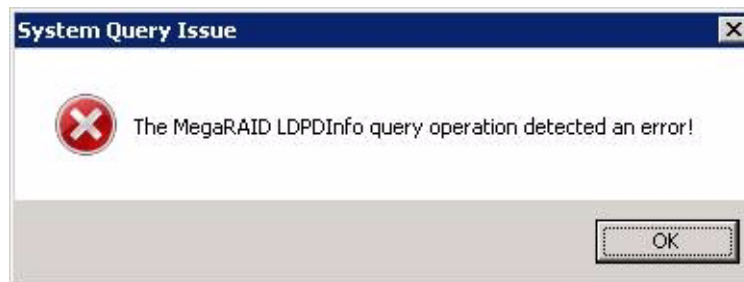



Figure 3-34 Zones – Error messages from improper path configuration

If the path for the tools are set incorrectly, they must be re-set and the Zones program closed and re-started for the correct paths to take effect.

Python for Windows

The CLI Zoning Tool requires Python, version 2.6 or 2.7, be installed on the machine that will perform the zoning.

1. Go to <http://www.python.org/download/releases/> and select the latest version of Python.
2. Download and start the installation.
3. The installation will ask which directory in which to install python (the default is `c:\Python##\` where ## is the version number).
4. On the **Customize Python** pane, click **Next**.
5. On the **Complete Python Installation** pane, click **Finish**.

CLI Zoning Tool for Windows

To install the CLI Zoning Tool software:

1. Go to <http://support.sgi.com>
2. Download the latest Windows version of the CLI Zoning Tool.
3. Unzip `ShackCLI_release_xxx`. The program will ask if you want to create a directory name for the `.zip` file, click **Yes**.

To run the CLI Zoning Tool, follow the instructions given in “CLI Zoning Tool” on page 109.

Verify Drives Seen in Windows

In Windows, open Server Manager (Figure 3-35). Verify that the only disks the system sees are system drives, and that they are labeled C : / .

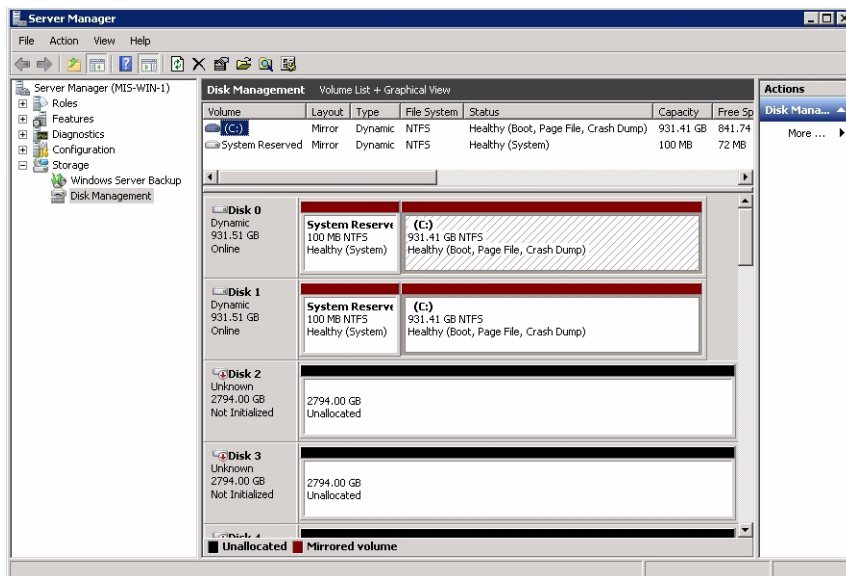

Figure 3-35 Windows Server Manager – Disk Management

Note: Unconfiguring drives removes them from the system.

Zones for Windows

The SGI Zones tool is a proprietary software program that uses a GUI interface to zone the drives in the MIS Server. Future releases will support zoning JBODs as well.

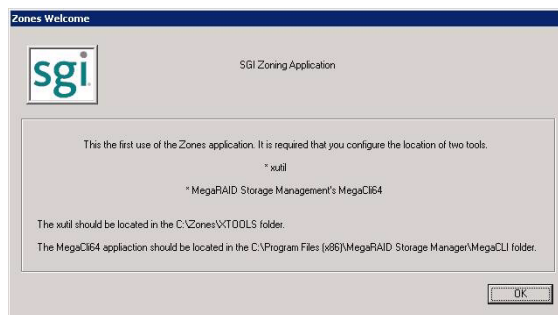

Figure 3-36 Zones for Windows Welcome

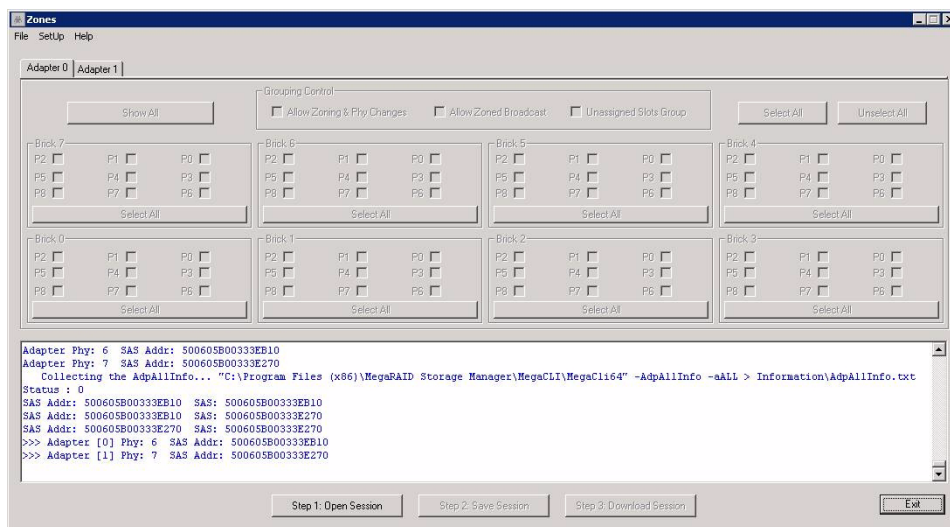

Figure 3-37 Zones Windows User Interface

To begin zoning, click the **Open Session** button (Figure 3-38). This queries each expander for the information contained in the expander .bin file.



Figure 3-38 Zones – Open Session, Save Session, Download Session, and Exit buttons

Click **Open New Session** (Figure 3-39).

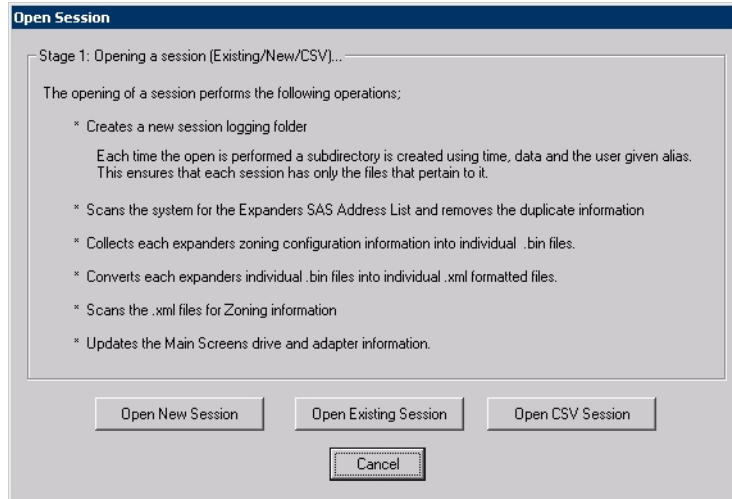

Figure 3-39 Zones – Open Session

The Zones program will ask you for a **Session Alias** (Figure 3-40). This alias will be added to a time stamp to create folder for that session's files: `YYMMDD_HHMMSS_alias`.

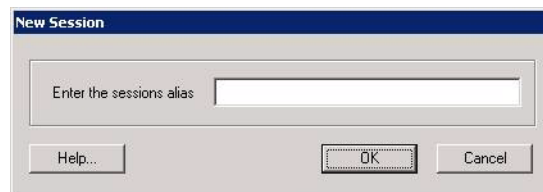

Figure 3-40 Zones – Enter Session Alias

Enter an alias and click **Okay**. Each expander card's information is fetched using `cmd.exe` and placed in the session folder as `.bin` files.

Note: Aliases have a 64 character limit, and may not contain spaces or non-alpha-numeric characters; these will be replaced with an underscore if used and a warning message will appear (Figure 3-41).

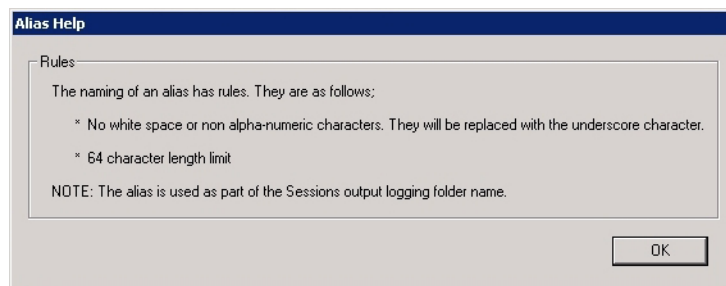

Figure 3-41 Zones – Alias Help Warning Message

In Zones for Windows, `.bin` files are automatically named `sb#_****.bin` where `sb` stands for StorBrick, `#` is the number of the StorBrick in question, and `****` are the last four digits of the expander card's SAS address. After the `.bin` file has been fetched, each file is converted into an XML file, named using the same convention, with the file extension `.xml` (e.g., `sb#_****.xml`).

Upon opening, Zones UI will show drives that are presently installed and zones that are currently active. A checkbox will be enabled to show that a drive is in a StorBrick. A check *mark* in a checkbox that is enabled shows that the drive is zoned for that adapter. Each adapter has its own tab above the StorBrick layouts (Figure 3-42). The number of **Adapter** tabs will directly correspond to the number of adapters Zones sees in the system.



Figure 3-42 Zones – Adapter tabs (Windows)

Installing a Drive in Zones for Windows

After creating a new session, click the **Show All** button. This enables all boxes on all adapters (Figure 3-43), even if there are no drives physically present. This is so a drive can be zoned to the system that isn't seen by the system yet.

Note: If a drive is zoned to more than one adapter, a warning message (Figure 3-44) will appear. In Windows, this warning tells which adapter that drive is already zoned to, and a message asking if you would like to continue. It is possible to zone one drive to two adapters. This is allowed, but not suggested, as it can cause data collisions.

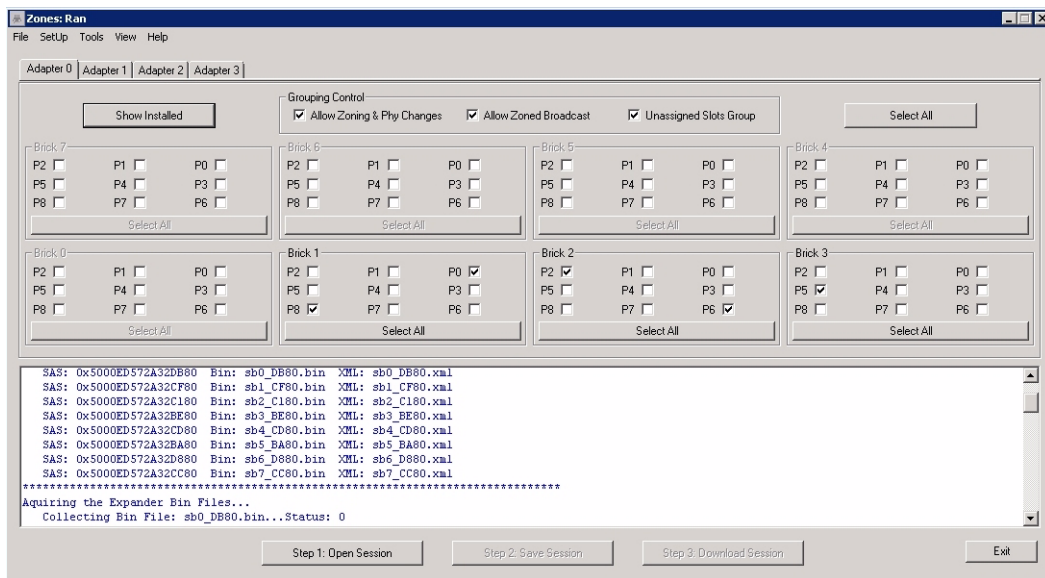

Figure 3-43 Zones – Show All

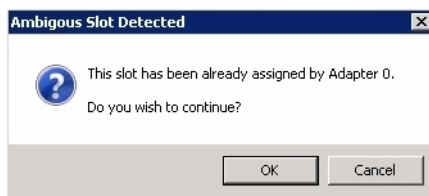

Figure 3-44 Zones – Adapter Assignment Warning Message

Check the boxes for the drives you want to zone, according to the configuration of your liking. Click **Save Session**. This takes the screen configuration and saves it to an .xml file that is then converted into a .bin file.

Note: The **Save Session** button will become enabled whenever a change has been made in the Zones configuration.

The name of the new .bin file is sbn#_****.bin where the only new element to the file name is the **n** after sb.

Important: Each time the **Save Session** button is pushed, these files are overwritten. There is no way to retrieve previously saved information.

Click the **Download** button. Once complete, this function pushes the .bin files back into the expanders. Select which StorBricks to push the files to, and click **Ok** to push the files.

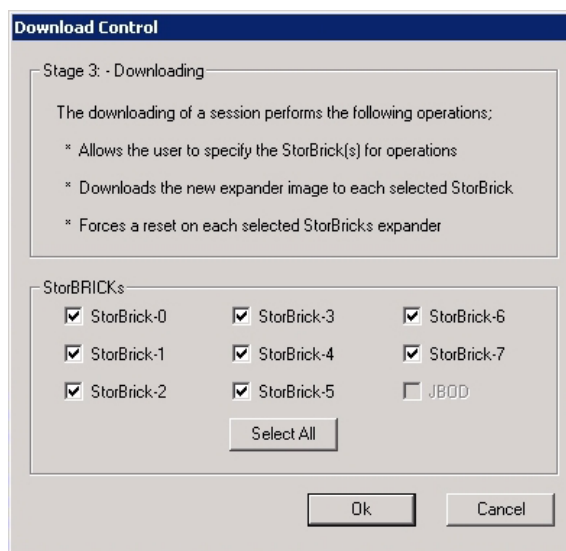

Figure 3-45 Zones – Select StorBricks for download

In Windows, a prompt will appear asking to confirm the download operation.

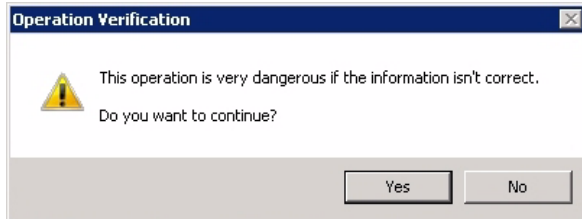

Figure 3-46 Zones tool – Verify download

Click **Yes** to verify and finish downloading. Power cycle the machine. Click **Ok** to power off the machine for power-cycling.

Creating the Drive Groups in MegaRAID for Windows

Power on the machine to complete power-cycle. Open MegaRAID. Right-click on the controller and select **Create a Virtual Drive** (Figure 3-47).

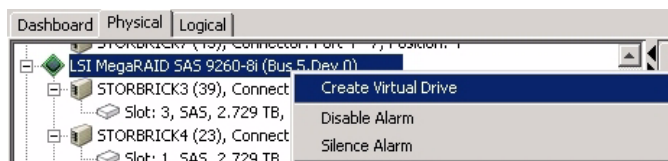

Figure 3-47 MegaRAID – Create a Virtual Drive

A screen will pop up asking you to choose **Simple** or **Advanced** (Figure 3-48). In Simple mode, the drives are chosen for you. In Advanced mode, you get to choose the drives, and are given additional selections in RAID levels, allowing for spanned (00, 10, 50, 60) drives.

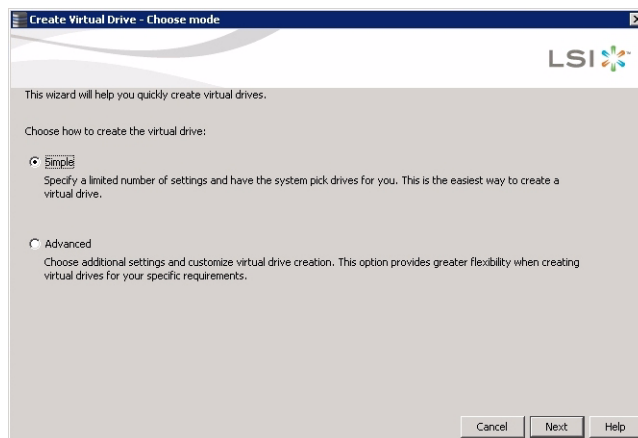

Figure 3-48 MegaRAID – Create Virtual Drive mode

Create the drive groups.

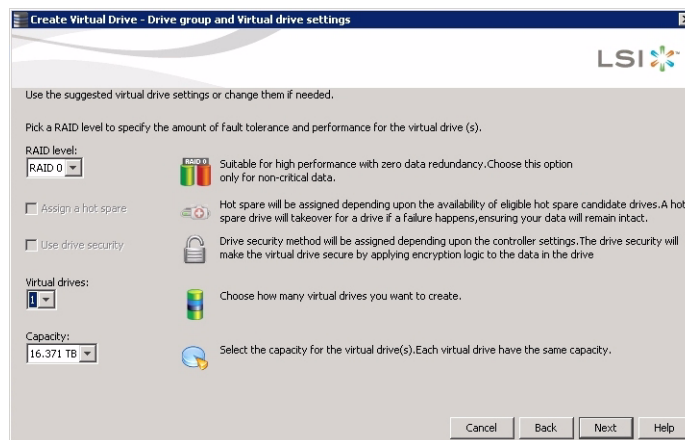

Figure 3-49 Create Virtual Drive – Simple Settings

Choose **Write Back BBU** (battery back-up unit). This mode is the safest and the fastest, and will automatically switch from caching mode to write-straight-to-disk whenever battery power has reached threshold. **Write Through** writes straight to disk. **Write Back** is a cached data flow.

Warning: If you select **Write Back** and power to the system is lost, data is lost.

Click **Next**, and a summary screen verifying settings will appear (Figure 3-50).

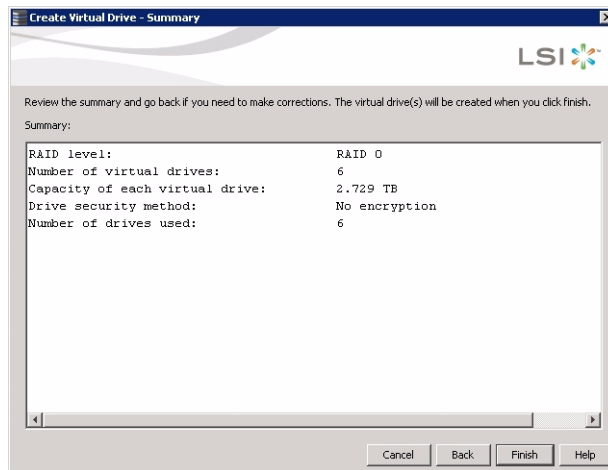

Figure 3-50 Create Virtual Drive – Summary

If the settings are correct, click **Finish**, and click **Ok**.

Formatting the Drives in Windows Server Manager

Drives are formatted using Windows Server Manager (Figure 3-51). Open **Server Manager**—the screen should start at **Disk Management** with the drives showing. If not, click **Storage** in the system tree, and click **Disk Management**. The collection of disks/raidsets will now show.

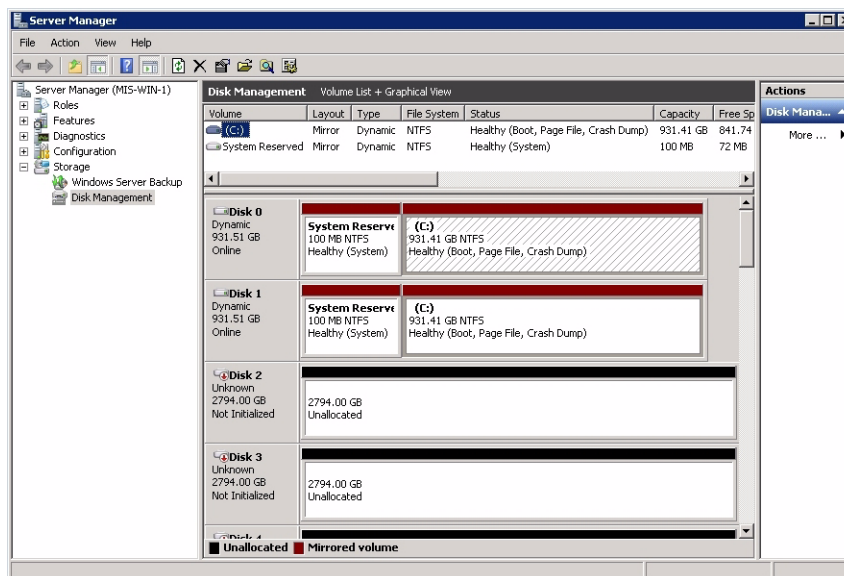

Figure 3-51 Server Manager – Disk Management

Right click in the grey area of the first non-system disk. In the menu that appears choose **Initialize Disk** (Figure 3-52).

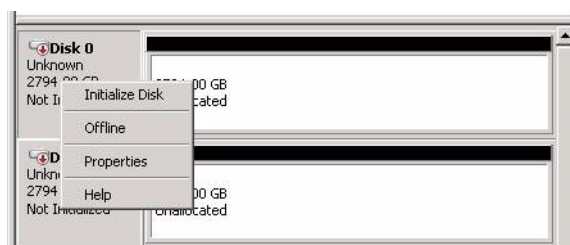

Figure 3-52 Server Manager – Initialize Disks

A pop-up window will appear, showing all the uninitialized disks (Figure 3-53).

Warning: Be sure to select **GPT** (GUID Partition Table).



Figure 3-53 Server Manager – Select GPT (GUID Partition Table)

Click **OK**. All the disks should now show as **Online** (Figure 3-54).

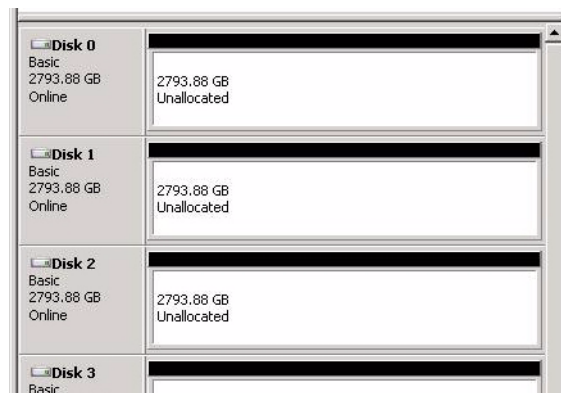

Figure 3-54 Server Manager – Disks Initialized and Online

Right click the first non-system disk. Select **New Simple Volume** (Figure 3-55).

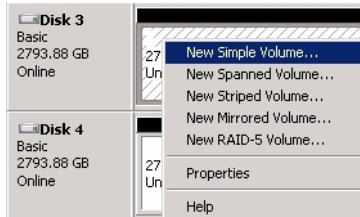

Figure 3-55 Server Manager – New Simple Volume

Click **Next** at the **New Simple Volume Wizard** welcome screen (Figure 3-56). Select the size of the volume in MB and click **Next** (Figure 3-57).



Figure 3-56 Server Manager – New Simple Volume Wizard

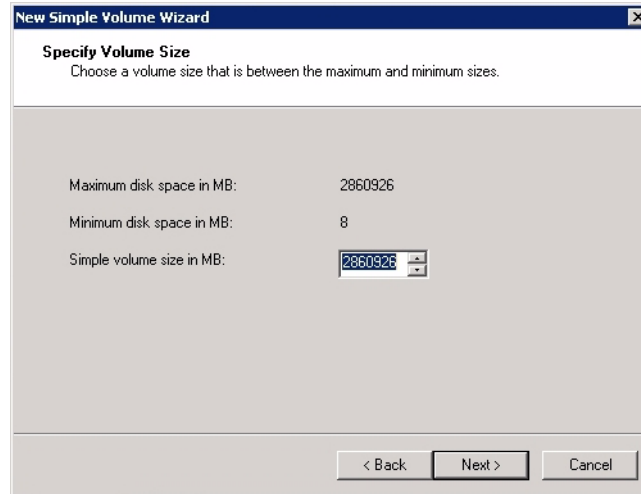

Figure 3-57 New Simple Volume Wizard – Volume Size

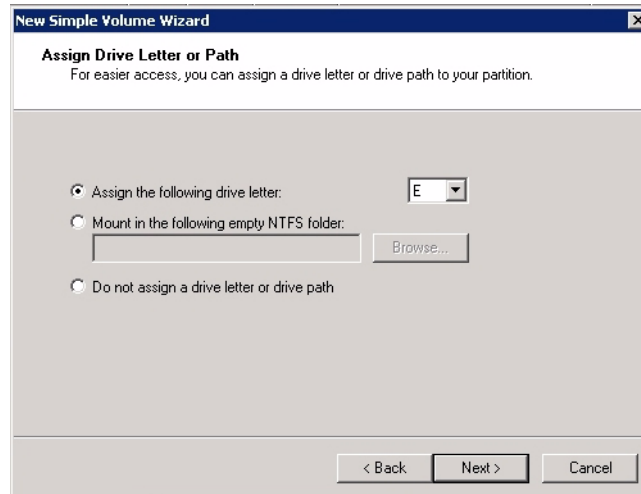

Figure 3-58 New Simple Volume Wizard – Assign Drive Letter or Path

Choose the drive letter to be assigned or click **Next** for the next drive letter available (Figure 3-58).

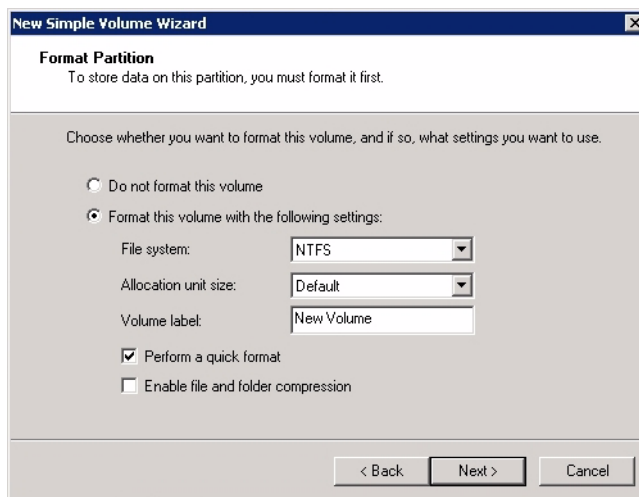

Figure 3-59 New Simple Volume Wizard – Format Partition

Select the format settings to be used, and click **Next** (Figure 3-59).

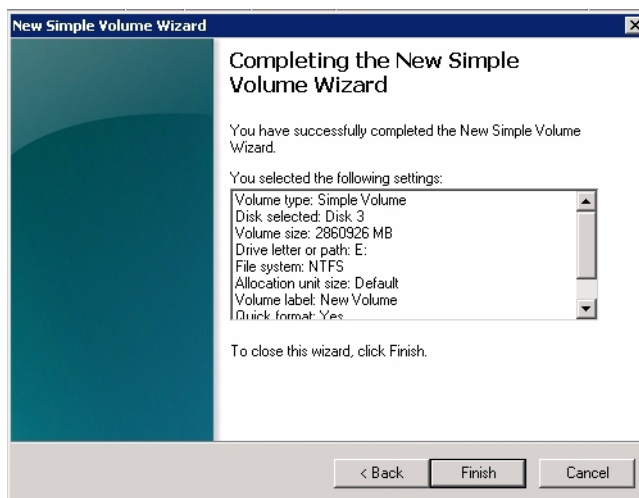

Figure 3-60 New Simple Volume Wizard – Settings Confirmation

Click **Finish** to format the disks (Figure 3-60). New volumes will show in the Disk Management window below the volumes (Figure 3-61).

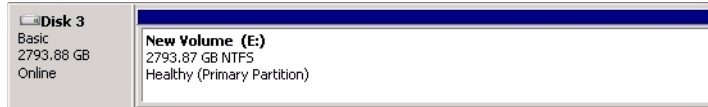

Figure 3-61 New Simple Volume in Server Manager

Removing a Drive in Zones for Windows

From the Zones user interface (Figure 3-37 on page 93), you can unzone a drive from an adapter by unchecking boxes. Once the drives are unzoned, click the **Save Session** button (Figure 3-38 on page 93). This action takes the configuration shown on the screen, saves it to an .xml file, that is then converted into a .bin file, and stores it on the expander card.

Note: The **Save Session** button will become enabled whenever a change has been made in the Zones user interface.

In Windows, the name of the new .bin file is sbn#_****.bin where the only new element to the file name is the **n** after sb.

Important: Each time the **Save Session** button is pushed, these files are overwritten. There is no way to retrieve previously saved information.

Click the **Download Session** button (Figure 3-38 on page 93). This function pushes the files back into the expanders. Select which StorBricks to push the files to, and click **Yes** (Figure 3-62) to push the files.

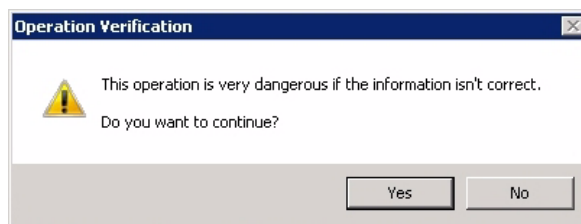

Figure 3-62 Zones – Verify Download

Power cycle the machine to have these changes take effect.

Additional Features in Zones for Windows

The Zones application also includes tools for loading a .csv file, adapter synchronization, and saving a .csv file.

Loading .csv Configuration Files in Zones for Windows

One option for zoning is editing zoning values in a .csv file, created through spreadsheet programs that support .csv file extension (e.g., Microsoft Excel). Zoning assignments done in this way will assign zoning at the hardware level, whereas zoning through the Zones GUI zones at the MegaRAID Storage Manager level, which may or may not correspond with the hardware. Synchronizing the two is handled at the hardware level and not through the Zones program (see “Adapter Assignment Synchronization in Zones for Windows” on page 108).

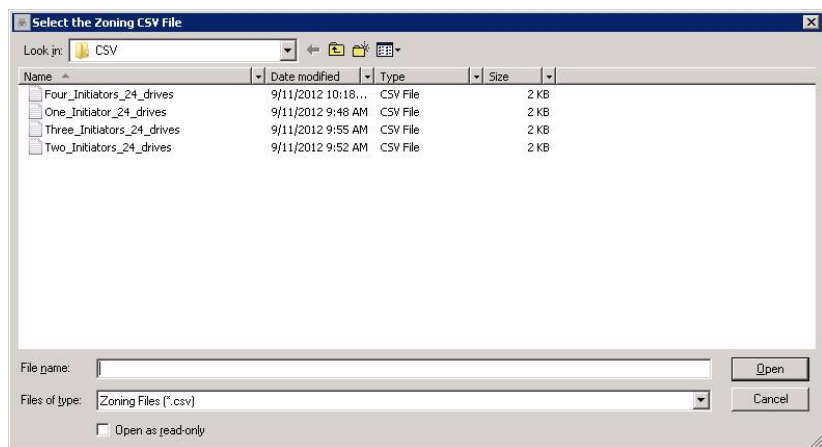

Figure 3-63 Zones – Select CSV File

To begin, select **Open Session** (Figure 3-38 on page 93). Select **Load CSV File**. The alias for the session is the .csv file name with the “.csv” removed. A **File Location** pane will open (Figure 3-63). Select the .csv file you wish to upload, and click **Okay**. The configuration entered in the .csv file will show in the Zones GUI (Figure 3-37 on page 93), with the exception that the zoning may need to be synchronized with the hardware, explained below.



Figure 3-64 Zones – Error message: Canceling csv file selection (Windows)

Note: If you wish to cancel selecting a .csv file, and click the **Cancel** button on the **Select the Zoning CSV File**, you will receive an error message (Figure 3-64). Click **Okay** to continue canceling the **Select .csv File** operation.

Adapter Assignment Synchronization in Zones for Windows

If the adapter assignment in the .csv file loaded (hardware-level assignment) does not correspond with how MegaRAID Storage Manager assigns the adapters (on a first-see/first-come software-level assignment), then Zones will show what drives are present on which adapters, but the zoning will not be there.

To fix this, select **Open Session** (Figure 3-39 on page 94). Select **Create New Session**, enter an alias for the session, and click **Ok**. Next, click the **Unselect All** button, located in the upper right corner of the Zones for Windows UI (Figure 3-65). Now you can assign the drives on the **Adapter** tabs, to configure the tool so that it is synchronized with the hardware. Click the **Step 2: Save Session** button, and then click the **Step 3: Download Session** button (Figure 3-38 on page 93). Select the StorBricks on which you wish to push the new configuration (usually all, in this instance – Figure 3-45 on page 97). Click **Ok**. Click **Yes** to power cycle the machine (i.e., let the MIS Platform shut down gracefully and then power it back on). This will change the MegaRAID assignment.



Figure 3-65 Zones – Select All, Unselect All buttons

Save a Configuration to .csv file in Zones for Windows

The Zones tool for Windows saves the configurations created in the GUI as a .csv file. This is done automatically when you save the session, and the .csv file is saved in the session folder.

CLI Zoning Tool

This initial release of the CLI Zoning tool introduces proprietary SGI software, used to zone drives on a MIS Server Platform and MIS JBOD units. The tool also supports diagnostic functions useful to Field Service.

In the T10 implementation, SAS zoning access control is implemented by linked switch and expander devices, with zoning enabled. These devices define a Zoned Portion of a Service Delivery System (ZPSDS). No host device intervention is required. Each zoning expander device within the MIS Enclosure maintains an identical zone permission table, so zone access control is maintained across the entire ZPSDS. The difference between the expanders lies in the definition of the PHY Zone groups that defines to which Zone Group (ZG) each of the 36 PHY's belongs. The Permission Table then maps the Initiator Zone Groups to the Target Zone groups.

The CLI Zoning Tool performs changes through the use of Comma Separated Values (CSV) files.

A Session is defined as the act of querying, editing, saving, and downloading the expander's binary zoning information.

Important: JBODs are zoned through the hardware using the CLI Zoning tool; only PHY-based Zoning is supported at this time.

The CLI Zoning Tool runs on any Windows/Linux host that has Python 2.6 or Python 2.7.1 installed. The target MIS JBOD/Server does not require an OS since the CLI Zoning Tool uses the FanBase Ethernet connection to access the StorBricks. The CLI Zoning Tool allows the zoning of drive groups larger than 72, hence, it is able to zone JBODs, and multiple JBODs, as single zones.

Table 3-1 is how the Zone Groups (ZG) are implemented in the MIS Enclosure. There are 256 possible ZG in the MIS Enclosure which allows for our maximum drive count of 162.

Table 3-1 Zone Group Implementation

Zone Group	Description
ZG0	The Dead Zone that only talks to ZG 127
ZG0 – ZG1	Always enabled
ZG2–3	Enabled for initiators
ZG2	For Initiators that have SMP Zoning Access
ZG3	Initiators that have access to Broadcast
ZG4–7	Reserved per SAS Specification
ZG8–15	The eight possible initiators
ZG16–96	For drives 0–80 for 81 possible drives
ZG97–127	Reserved in the MIS implementation

A configuration file is used by the CLI application to zone the StorBricks. **A set of standard configuration files are included with the CLI Zoning Tool software package.** A custom file can be created, using a spreadsheet application and then saving it as a .csv file (see “Editing the .csv File for the CLI Zoning Tool” on page 119).

Preparing to Zone using the CLI Zoning Tool

CLI Zoning uses the MIS-S9D proprietary network interface. This interface is to be used **ONLY** when zoning. It is located at the front of the chassis at the upper right corner (Figure 3-66). The chassis must be slid out forward at least one inch in order to connect a network crossover cable. (See “Sliding the Chassis Forward/Backwards,” on page 134.)



Figure 3-66 MIS-S9D proprietary network interface

Ensure the MIS system is powered on. Use an Ethernet crossover cable to connect a server/laptop running either a Windows or a Linux operating system and the CLI Zoning application software. The network port connected to the server/laptop must be set to 192.168.0.xxx (10 will do). The static IP address of the Fan Base is set to 192.168.0.3, verify connectivity to the Fan Base with a ping command to 192.168.0.3 from the server/laptop. Verify it responds. If not it will be necessary to power cycle the MIS server or JBOD.

Editing the ShackCLI.ini file for Linux

In the /opt/ShackCLI directory, open up the ShackCLI.ini file with an editor or vi.

The following is a sample file:

```
[main]
# Input filename. This must be either a pathname or a simple
# dash (-), which signifies we'll use standard in.
input_source = cli
target = 192.168.0.3
[maxsize]
# When we hit this threshold, we'll alert for maximum
# file size.
threshold = 100
[display]
show_footer = yes
# Fill up all SB information before going to Menu
auto_fill = no
[default]
#MIS_Variant = JBOD
```

```
MIS_Variant = SERVER
storbrick = 0 1 2 3 4 5 6 7
#storbrick = 0 1 2 3 4 5 6 7 8
cmd = menu
pcsv = /opt/ShackCLI/MIS-Server_2HBA_zoning_PCSV.csv
pbcsv = /opt/ShackCLI/MIS-JBOD_1-IOMOD_zoning_PBCSV.csv
zcsv = /opt/ShackCLI/Zone_Phys_Default.csv
max_zones = 255
max_phys = 36
response_delay_default = 20
```

First, verify that the target IP address is 192.168.0.3 and is not commented out (i.e., there is no # at the beginning of the line). Next, make the needed changes to the file, as follows.

1. Set the MIS Variant to the type of system to be zoned, JBOD or SERVER. (Be sure the other is commented out.)
2. Change the StorBrick count to be either 0–7 for a server, or 0–8 for a JBOD.
3. Select the type of zoning file to be used `pcsv`, `zcsv`, or `pbcsv`.
4. Add the path to where the configuration file is located.
5. Unless issues develop, leave the remaining selections at default.
6. Save the `ShackCLI.ini` file and close.
7. Execute the CLI command: `python ShackCLI.py --ini ShackCLI.ini --cmd menu`.

This will set the StorBricks to debug mode, and display a menu (“CLI Zoning Tool Main Menu” on page 113).

Editing the ShackCLI.ini file for Windows

In the `C:\python##\` directory, open up the `ShackCLI.ini` file with an editor or vi.

The following is a sample file:

```
[main]
# Input filename. This must be either a pathname or a simple
# dash (-), which signifies we'll use standard in.
input_source = cli
target = 192.168.0.3
[maxsize]
# When we hit this threshold, we'll alert for maximum
# file size.
threshold = 100
```

```

[display]
show_footer = yes
# Fill up all SB infomation before going to Menu
auto_fill = no
[default]
#MIS_Variant = JBOD
MIS_Variant = SERVER
storbrick = 0 1 2 3 4 5 6 7
#storbrick = 0 1 2 3 4 5 6 7 8
cmd = menu
pcsv = C:\python##\MIS-Server_2HBA_zoning__PCSV.csv
pbcsv = C:\python##\MIS-JBOD_1-IOMOD_zoning_PBCSV.csv
zcsv = C:\python##\Zone_Phy_Default.csv
max_zones = 255
max_phys = 36
response_delay_default = 20

```

First, verify that the target IP address is 192.168.0.3 and is not commented out (i.e., there is no # at the beginning of the line). Next, make the needed changes to the file, as follows.

1. Set the MIS Variant to the type of system to be zoned, JBOD or SERVER. (Be sure the other is commented out.)
2. Change the StorBrick count to be either 0–7 for a server, or 0–8 for a JBOD.
3. Select the type of zoning file to be used pcsv, zcsv, or pbcsv.
4. Add the path to where the configuration file is located.
5. Unless issues develop, leave the remaining selections at default.
6. Save the ShackCLI.ini file and close.
7. Execute the CLI command: `python ShackCLI.py --ini ShackCLI.ini --cmd menu`.

This will set the StorBricks to debug mode, and display a menu (“CLI Zoning Tool Main Menu”).

CLI Zoning Tool Main Menu

The main menu of the CLI Zoning Tool gives the following options, as listed below and described in Table 3-2.

- 1) Set Active Storbrick(s)
- 2) Display Current StorBrick(s) Zoning
- 3) Update StorBrick(s) Permissions Table From CSV
- 4) Update StorBrick(s) Phy Zones From CSV
- 5) Update StorBrick(s) Phy Based Zoning from CSV

- 6) Change Zoning type (Server <-> JBOD)
- 7) Save current StorBrick(s) Zoning to CSV
- 8) Display StorBrick(s) Settings
- 9) Display CLI Settings
- 10) Enter StorBrick CLI (Must select a single StorBrick)
- 11) Reboot FanBase - will not reset StorBricks
- 12) Reset FanBase - Danger. This will reset StorBricks
- 13) Force Storbrick(s) into Debug Mode
- 14) Exit Storbrick(s) Debug Mode
- 15) Display PHY Error Counters for selected StorBricks
- 16) Display PHY Information for selected StorBricks
- 17) Display StorBrick UUID for selected StorBricks
- 18) Display StorBrick Firmware Revision Levels for Selected StorBricks
- 0) Exit CLI - back to command prompt

Table 3-2 CLI Zoning Tool Menu Options and Descriptions

Menu Option	Description
1) Set Active Storbrick(s)	This menu option allows user to select the StorBrick(s) to act upon. The StorBricks may be entered in any order: 0 1 2 3 4 5 6 7 or 7 6 5 4 3 2 1 0, or in subsets: 0 or 0 1, etc. Storbrick numbers must be less than or equal 7 for MIS Server and less than or equal 8 for MIS JBOD.
2) Display Current StorBrick(s) Zoning	Displays the Zoning configuration that is currently stored in the StorBricks.
3) Update StorBrick(s) Permissions Table From CSV	This menu option uses the csv file described in the ini file under the heading 'pcsv' to modify the T10 Zoning Permission Tables for the selected StorBricks. If no csv file has been specified in the ini file the CLI Zoning Tool will prompt the user for the name of the csv file to use.
4) Update StorBrick(s) Phy Zones From CSV	This menu option uses the csv file described in the ini file under the heading 'zcsv' to modify the T10 PHY Zone Groups for the selected StorBricks. If no csv file has been specified in the ini file the CLI Zoning Tool will prompt the user for the name of the csv file to use.

Table 3-2 CLI Zoning Tool Menu Options and Descriptions **(continued)**

Menu Option	Description
5) Update StorBrick(s) Phy Based Zoning from CSV	This menu option uses the <code>csv</code> file described in the <code>ini</code> file under the heading 'pbcsv' to modify the PHY Based Zoning Tables for the selected StorBricks. This is the only supported Zoning configuration for MIS JBOD and is an optional configuration for MIS Server and MIS DC Server. Only one of PHY Based and T10 Zoning should be implemented within an MIS Server (although it is technically possible to mix the Zoning types) and only one of PHY Based Zoning may be supported in an MIS JBOD.
6) Change Zoning type (Server <-> JBOD)	This menu option allows the user to change the zoning type from SERVER/JBOD to JBOD/SERVER. This command will cause the Selected STORBRICKS T10 Supported flag to be set/unset depending what the current Zoning type is. For Example, if the current Zoning type is PHY Based and the user selects this option then the T10 Zoning Supported flag will be set enabling T10 Zoning to be implemented instead.
7) Save current StorBrick(s) Zoning to CSV	This menu option allows the user to save the current configuration of the Enclosures Zoning in a file. This file is compatible with the CLI commands that require a <code>csv</code> file to update Zoning. The <code>csv</code> file format for PHY Based and T10 Zoning are identical therefore one use of this command is to dump a MIS system's T10 Zoning configuration and then rewrite the same file as a PHY Based configuration.
8) Display StorBrick(s) Settings	This menu option simply displays information about the selected StorBricks such as their SAS Addresses.
9) Display CLI Settings	This menu option simply displays information about the CLI Zoning Tool that is generally contained in the <code>ini</code> file but may be changed in the course of operating the CLI Zoning Tool through CLI commands.
10) Enter StorBrick CLI (Must select a single StorBrick)	This menu option is for Diagnostics support only.
11) Reboot FanBase - will not reset StorBricks	This menu option will invoke a soft reboot of the FanBase and no StorBricks shall be reset.

Table 3-2 CLI Zoning Tool Menu Options and Descriptions **(continued)**

Menu Option	Description
12) Reset FanBase - Danger. This will reset StorBricks	This menu option will invoke a cold start of the FanBase and all StorBricks shall be reset.
13) Force Storbrick(s) into Debug Mode	This menu option places the selected StorBrick(s) into debug mode which allows most of the other menu options to work. At start of day all StorBrick(s) defined in the ini file will automatically be put in Debug Mode therefore it is not generally necessary to run this command.
14) Exit Storbrick(s) Debug Mode	Has no affect at this time and is reserved for future implementations.
15) Display PHY Error Counters for selected StorBricks	This menu option displays all the PHY Error Counters for the Selected StorBrick(s).
16) Display PHY Infomation for selected StorBricks	This menu option displays all the PHY information for the selected StorBrick(s). this information includes the PHY's connected link rate, Zone Group and SAS/SATA connection types.
17) Display StorBrick UUID for selected StorBricks	This menu option displays the UUID for the selected StorBrick(s). The UUID is displayed in human readable form.
18) Display StorBrick Firmware Revision Levels for Selected StorBricks	This menu option displays all the Firmware Revision Level information for the selected StorBrick(s).
0) Exit CLI - back to command prompt	This menu option will exit the CLI Zoning Tool.

Note: Options 10, 13 and 14 are to be used ONLY with the assistance of technical support.

Here are the valid Command Line commands:

```
usage: ShackCLI.py [-h] --cmd CMD [--sbcmd SBCMD] [--target TARGET]
                [--sb SB] [--ini INI] [--zcsv ZCSV] [--pcsv PCSV]
                [--zones ZONES] [--delay DELAY] [--pbcsv PBCSV]
                [--mistype MISTYPE] [--v, V]
```

MIS Command Line Interface optional arguments:

```

-h, --help          show this help message and exit
--cmd CMD           command to execute
--sbcmd SBCMD       Command to send to SB
--target TARGET     target ip address (if not 192.168.0.3)
--sb SB             Index(s) of StorBrick
--ini INI           Initialization file
--zcsv ZCSV         CSV file name for Zoning PHY Groups
--pcsv PCSV         CSV file name for Zoning Permission Tables
--zones ZONES       Maximum Permission Table Entries
--delay DELAY       FanBase delay before expect StorBrick result
--pbcsv PBCSV       CSV file name for Phy Based Zoning
--mistype MISTYPE   JBOD or SERVER
--v, V             Display the version of the Shack CLI

```

In the menu above, this executes option 2:

```
python ShackCLI.py -ini ShackCLI.ini -cmd dzone
```

This executes option 3:

```
python ShackCLI.py -ini ShackCLI.ini -cmd uperm
```

This executes option 4:

```
python ShackCLI.py -ini ShackCLI.ini -cmd uphyz
```

This executes option 5:

```
python ShackCLI.py -ini ShackCLI.ini -cmd uphyb
```

Zoning Using CLI Zoning Tool

First, select option 2 from the Main Menu to display the current zoning. When displayed, 0 indicates that the path to that drive is disabled. An x indicates that it is active to that SAS path. For the MIS-Server, Initiator0 = SAS lane 0 which is connected to HBA-A lane 0, initiator1 = SAS lane 1 which is connected to HBA-B lane 0, initiator2 = SAS lane 2 which is connected to HBA-C lane 0, initiator3 = SAS lane 3 which is connected to HBA-D lane 0. Initiator4-7 are not used at this time and will be set to 0. Since the .csv data is organized by drives, and the drives are numbered by StorBrick, we can start at SB[0:0]. The drive numbers in an MIS Enclosure are numbered from 0-143 for the MIS Server and 0-162 for the MIS JBOD.

Example (truncated, lines 021–190 & 195–250, for space):

```
StorBrick 0 Permission Table
```

18	095	Yes	No	No
19	023	Yes	No	No
20	024	Yes	No	No
21	096	Yes	No	No
22	021	Yes	No	No
23	093	Yes	No	No
24	090	Yes	No	No
25	018	Yes	No	No
26	220	Yes	No	No
27	220	Yes	No	No
28	220	Yes	No	No
29	220	Yes	No	No
30	220	Yes	No	No
31	220	Yes	No	No
32	220	Yes	No	No
33	220	Yes	No	No
34	220	Yes	No	No
35	220	Yes	No	No

When ready to zone, complete the following instructions.

1. Execute option 7 to make a copy of the current configuration (be sure to add `.csv` as the file extension). Example: `MIS-System1-zoning-092012-121103.csv`
2. Edit the `.csv` file to the desired zone configuration. Once satisfied, save the file with a different name so as not to over write the saved one.
3. Change the name in the `ShackCLI.ini` file to point it to the new file.
4. Select the update option that fits the configuration (option 3, 4, or 5).
5. Select option 12 to reset the StorBricks and invoke the zoning changes.
6. Verify that the zoning is correct by executing option 2 and reviewing the configuration file.
7. Power cycle the MIS server and reboot any head-of-string controller of a JBOD to refresh the information in the servers.

Once power-cycling is complete, verify the changes by executing the command:

```
python ShackCLI.py -ini ShackCLI.ini -cmd dzone.
```

If satisfied, disconnect from the MIS-S9D network interface, and slide the chassis back into the rack.

Editing the `.csv` File for the CLI Zoning Tool

A configuration file made of comma separated values (a “`csv`” file) is used by the CLI application to zone the StorBricks. A set of standard configuration files are included with the software

package. A custom file can be created, using a spreadsheet application and then saving it as a .csv file.

Figure 3-67 is a block diagram of MIS JBOD StorBrick SB0. The other 8 StorBrick for the MIS JBOD repeat this, but are offset to other lanes from the I/O modules.

Table 3-3 gives a portion of a csv file. A 1 in the spreadsheet indicates that the drive in question is accessible by the above HBA. The 0 indicates that the path is disabled.

Table 3-3 Zone Group Implementation

SB0 Drive	HBA-A Indicator 1	HBA-B Indicator 2	HBA-C Indicator 3	HBA-D Indicator 4	N/U Indicator 5	N/U Indicator 6	N/U Indicator 7	N/U Indicator 8
0	1	0	0	0	0	0	0	0
1	0	1	0	0	0	0	0	0
2	0	0	1	0	0	0	0	0
3	0	0	0	1	0	0	0	0
4	1	0	0	0	0	0	0	0
5	0	1	0	0	0	0	0	0
6	0	0	1	0	0	0	0	0
7	0	0	0	1	0	0	0	0
8	1	0	0	0	0	0	0	0

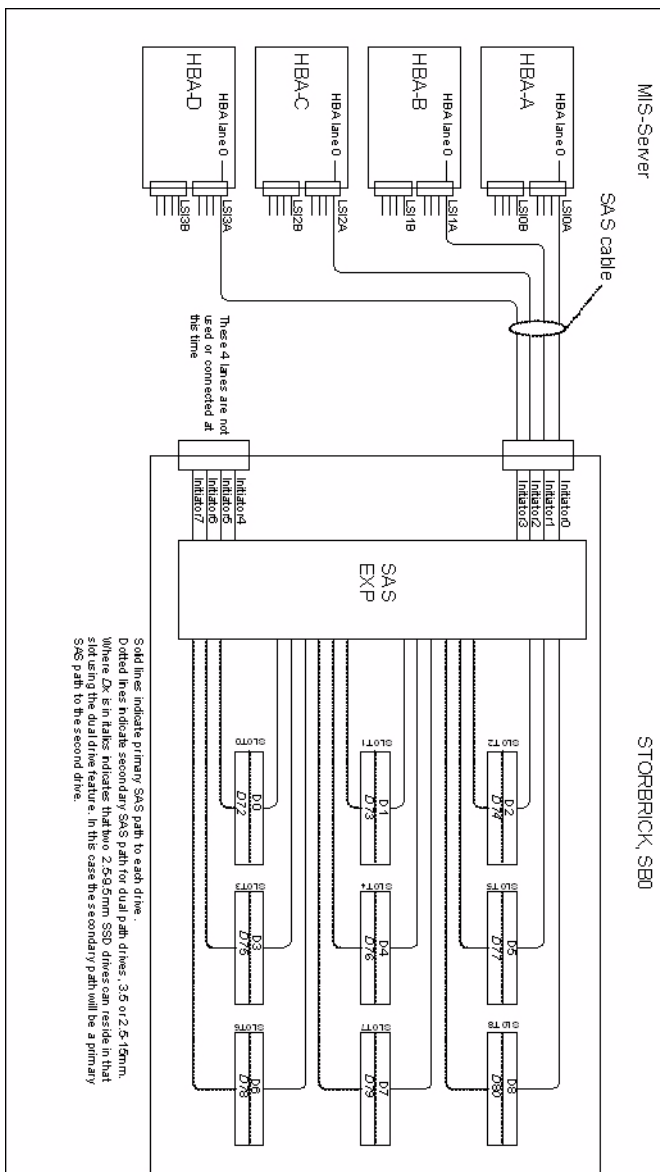

Figure 3-67 Block diagram of MIS-Server StorBrick SB0

Disk RAID Support

The MIS Platform supports both software and hardware RAID, standard and nested. Disk performance is improved because more than one disk can be accessed simultaneously. Fault tolerance is improved because data loss caused by a hard drive failure can be recovered by rebuilding missing data from the remaining data or parity drives.

The MIS Platform supports the following RAID levels:

- RAID 0 (striping without parity or mirroring, Figure 3-68)
- RAID 1 (mirrored without parity or striping, Figure 3-69)
- RAID 5 (striping with parity, Figure 3-70)
- RAID 6 (striping with dual parity, Figure 3-71)
- RAID 00 (spanned drive group striped set from a series of RAID 0 drive groups, Figure 3-72)
- RAID 10 (mirrored stripes across spanned drive groups, Figure 3-73)
- RAID 50 (distributed parity and striping across spanned drive groups, Figure 3-74)
- RAID 60 (distributed parity, with two independent parity blocks per stripe in each RAID set, and disk striping across spanned drive groups, Figure 3-75)

The onboard MIS server zoning application is supported in both Windows and Linux operating systems. There is also an external FanBase CLI, where a system running either Windows or Linux can be used to zone the JBOD in addition to MIS Servers. When LSI MegaRAID HBAs are used, they support RAID 0, RAID 1, RAID 5 and RAID 6, along with their variants. Where ever possible, the zoning and RAID selection for a MIS server should provide for the maximum amount of availability in the event of a StorBrick failure. The StorBrick has four SAS lanes into it from up to four SAS RAID HBAs. These SAS lanes are inputs to a SAS expander that connects to the drives installed in the StorBrick. Since there are eight StorBrick in the MIS-Server, each with nine drives, the highest availability for the data would be RAID groupings that span the StorBricks. More information and examples provided in “RAID Configuration Notes” on page 129.

Important: Unless specified, all systems ship as RAID 6.

RAID 0

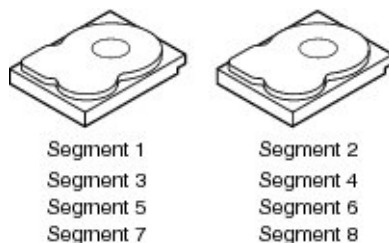

Figure 3-68 RAID 0

A RAID 0 splits data evenly across two or more disks (striped) without parity information for speed. RAID 0 provides no data redundancy. It provides improved performance and additional storage, but no fault tolerance. RAID 0 is normally used to increase performance, although it can also be used as a way to create a large logical disk out of a two or more physical ones. RAID 0 provides high data throughput, especially for large files in an environment that does not require fault tolerance.

RAID 0 is useful for setups such as large read-only NFS servers, where mounting many disks is time-consuming or impossible and redundancy is irrelevant. Any drive failure destroys the array, and the likelihood of failure increases with more drives in the array (at a minimum, catastrophic data loss is almost twice as likely compared to single drives without RAID). A single drive failure destroys the entire array because when data is written to a RAID 0 volume, the data is broken into fragments called blocks. The number of blocks is dictated by the stripe size, which is a configuration parameter of the array. The blocks are written to their respective drives simultaneously on the same sector. This allows smaller sections of the entire chunk of data to be read off each drive in parallel, increasing bandwidth. RAID 0 does not implement error checking, so any error is uncorrectable. More drives in the array means higher bandwidth, but greater risk of data loss.

RAID 1

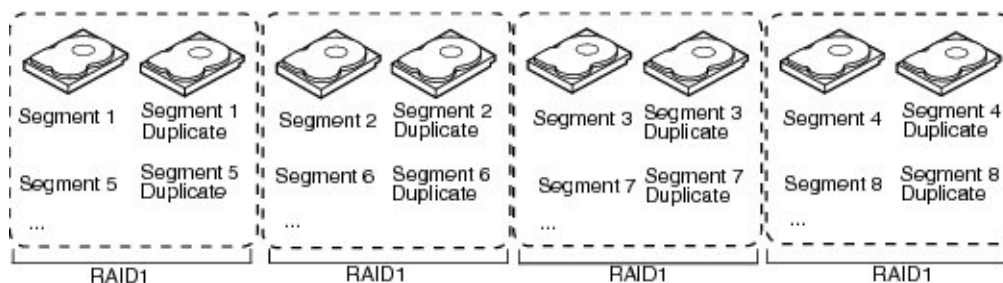

Figure 3-69 RAID 1

A RAID 1 writes identically to two drives, thereby producing a “mirrored set” (at least two drives are required to constitute such an array). This is useful when read performance or reliability is more important than data storage capacity. Such an array can only be as big as the smallest member disk. A classic RAID 1 mirrored pair contains two disks, which increases reliability geometrically over a single disk. Since each member contains a complete copy of the data, and can be addressed independently, ordinary wear-and-tear reliability is raised by the power of the number of self-contained copies.

The array continues to operate as long as at least one drive is functioning. With appropriate operating system support, there can be increased read performance, and only a minimal write performance reduction; implementing RAID 1 with a separate controller for each drive in order to perform simultaneous reads (and writes) is sometimes called multiplexing (or duplexing when there are only two drives). RAID 1 is good for applications that require small capacity, but complete data redundancy. (The server boot drive modules are configured for RAID 1.)

RAID 5

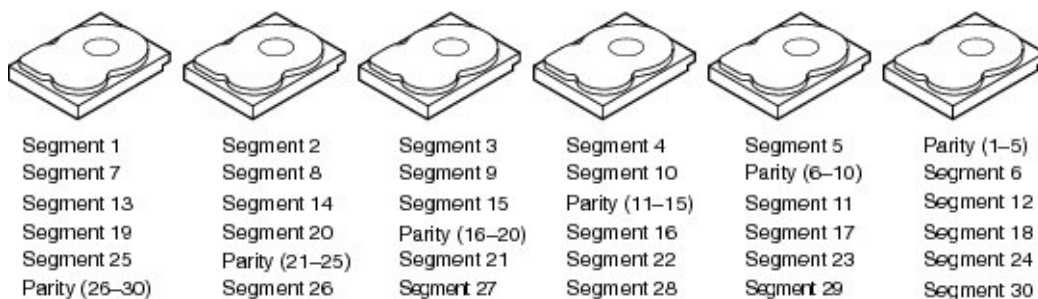

Figure 3-70 RAID 5

A RAID 5 uses block-level striping with parity data distributed across all member disks, creating low-cost redundancy. In most implementations, a minimum of three disks is required for a complete RAID 5 configuration. A concurrent series of blocks—one on each of the disks in an array—is collectively called a stripe. The disk used for the parity block is staggered from one stripe to the next, hence the term distributed parity blocks. RAID 5 writes are expensive in terms of disk operations and traffic between the disks and the controller. RAID 5 striping and distributed parity data across all drives provides high data throughput, especially for small, random access. Fault tolerance is maintained by ensuring that the parity information for any given block of data is placed on a drive separate from those used to store the data itself. The performance of a RAID 5 array can be “adjusted” by trying different stripe sizes until one is found that is well-matched to the application being used.

RAID 6

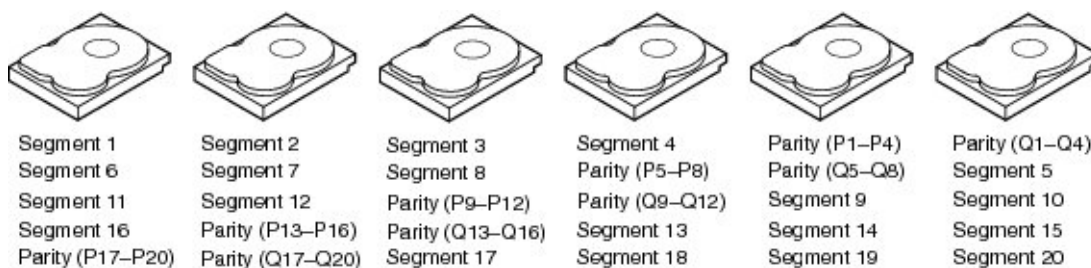

Figure 3-71 RAID 6

RAID 6 (block-level striping with double distributed parity) extends RAID 5 by adding an additional parity block. RAID 6 does not have a performance penalty for read operations, but it does have a performance penalty on write operations because of the overhead associated with parity calculations. Any form of RAID that can continue to execute read and write requests to all of a RAID array's virtual disks in the presence of any two concurrent disk failures. This makes larger RAID groups more practical, especially for high-availability systems. This becomes increasingly important as large-capacity drives lengthen the time needed to recover from the failure of a single drive. Single-parity RAID levels are as vulnerable to data loss as a RAID 0 array until the failed drive is replaced and its data rebuilt; the larger the drive, the longer the rebuild takes. Double parity gives additional time to rebuild the array without the data being at risk if a single additional drive fails before the rebuild is complete. Like RAID 5, a single drive failure results in reduced performance of the entire array until the failed drive has been replaced and the associated data rebuilt.

RAID 00

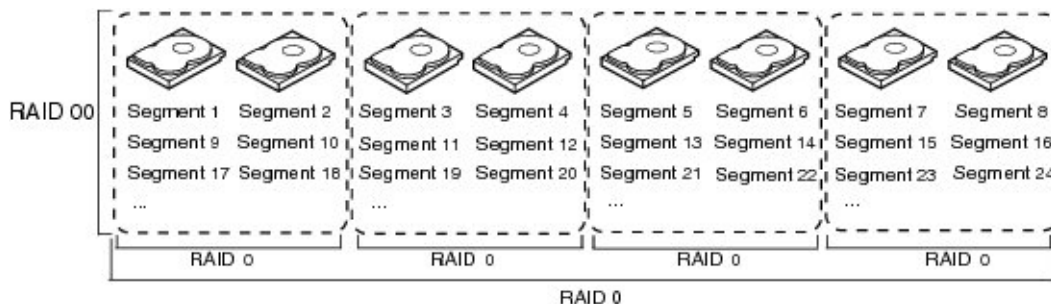

Figure 3-72 RAID 00

A RAID 00 drive group is a spanned drive group that creates a striped set from a series of RAID 0 drive groups. RAID 00 does not provide any data redundancy, but along with RAID 0, RAID 00 offers the best performance of any RAID level. RAID 00 breaks up data into smaller segments and stripes the data segments across each drive in the drive groups. The size of each data segment is determined by the stripe size. RAID 00 offers high bandwidth.

Note: RAID level 00 is not fault tolerant. If a drive in a RAID 0 drive group fails, the whole virtual drive (all drives associated with the virtual drive) fails.

By breaking up a large file into smaller segments, the RAID controller can use both SAS drives and SATA drives to read or write the file faster. RAID 00 involves no parity calculations to complicate the write operation, which makes RAID 00 ideal for applications that require high bandwidth but do not require fault tolerance. Figure 3-72 shows an example of a RAID 00 drive group.

RAID 10

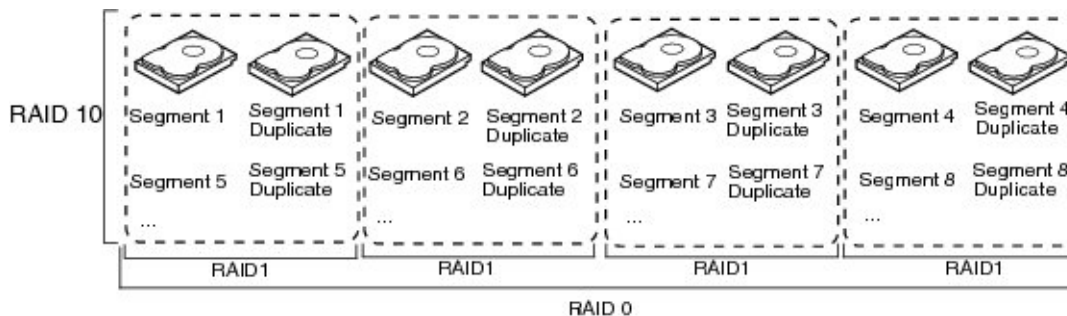

Figure 3-73 RAID 10

RAID 10 is a combination of RAID 0 and RAID 1 and consists of stripes across mirrored spans. RAID 10 breaks up data into smaller blocks and mirrors the blocks of data to each RAID 1 drive group. The first RAID 1 drive in each drive group then duplicates its data to the second drive. The size of each block is determined by the stripe size parameter, which is set during the creation of the RAID set. The RAID 1 virtual drives must have the same stripe size.

Spanning is used because one virtual drive is defined across more than one drive group. Virtual drives defined across multiple RAID 1 level drive groups are referred to as RAID level 10, (1+0). Data is striped across drive groups to increase performance by enabling access to multiple drive groups simultaneously.

Each spanned RAID 10 virtual drive can tolerate multiple drive failures, as long as each failure is in a separate drive group. If there are drive failures, less than the total drive capacity is available.

RAID 50

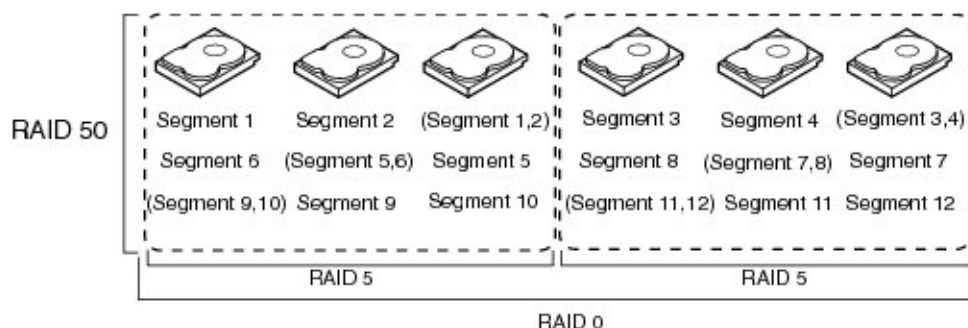

Figure 3-74 RAID 50

A RAID 50 combines the straight block-level striping of RAID 0 with the distributed parity of RAID 5. This is a RAID 0 array striped across RAID 5 elements. It requires at least 6 drives. RAID 50 improves upon the performance of RAID 5 particularly during writes, and provides better fault tolerance than a single RAID level does. This level is recommended for applications that require high fault tolerance, capacity and random positioning performance.

As the number of drives in a RAID set increases, and the capacity of the drives increase, this impacts the fault-recovery time correspondingly as the interval for rebuilding the RAID set increases. RAID 50 works best with data that requires high reliability, high request rates, high data transfers, and medium-to-large capacity.

RAID 60

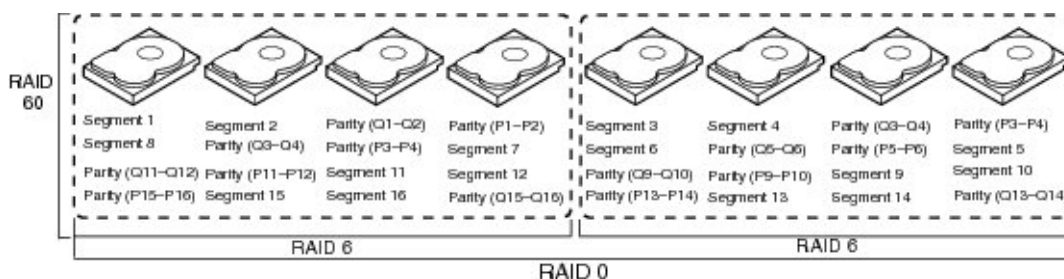

Figure 3-75 RAID 60

A RAID 60 combines the straight block-level striping of RAID 0 with the distributed double parity of RAID 6. That is, a RAID 0 array striped across RAID 6 elements. As it is based on RAID 6, two disks from each of the RAID 6 sets could fail without loss of data. Also failures while a single disk is rebuilding in one RAID 6 set will not lead to data loss. RAID 60 has improved fault tolerance, any two drives can fail without data loss and up to four total as long as it is only two from each RAID 6 sub-array.

Striping helps to increase capacity and performance without adding disks to each RAID 6 set (which would decrease data availability and could impact performance). RAID 60 improves upon the performance of RAID 6. Despite the fact that RAID 60 is slightly slower than RAID 50 in terms of writes due to the added overhead of more parity calculations, when data security is concerned this performance drop may be negligible.

RAID Configuration Notes

To get the best availability, treat each drive brick as an enclosure. For a RAID 1 with only one drive per StorBrick in the group, the loss of a StorBrick does not affect the availability of the data (Figure 3-76).

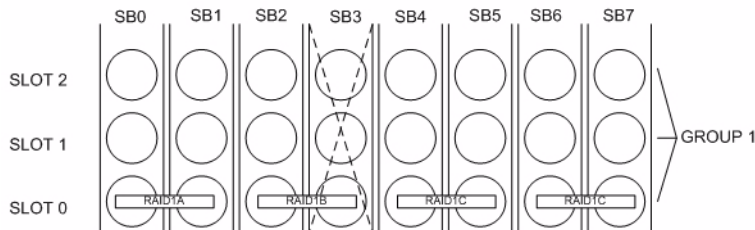

Figure 3-76 RAID 1 with one drive per StorBrick

However, with two drives spanning a StorBrick, the loss of a StorBrick will cause the data to be unavailable until the failed storbrick is replaced (Figure 3-77).

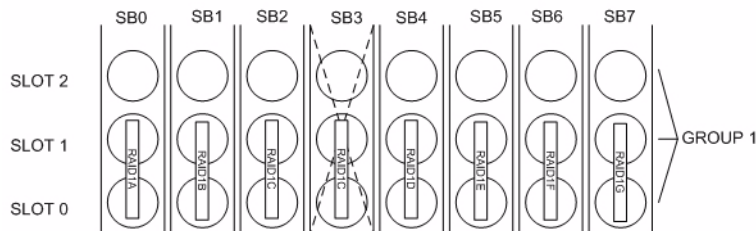

Figure 3-77 RAID 1 with two drives spanning a StorBrick

For redundancy, choose one drive from each drive brick as you build the LUNs. Configure the drives in a RAID group to span the StorBricks. For instance, configuring 8 drives from StorBrick 0 as a RAID5, 7+1 group will work. However, if that StorBrick (StorBrick 0) fails, all 8 drives will become inaccessible, making that RAID group's data unavailable until the StorBrick is replaced.

If, however, drive 0 from each StorBrick (SB0-0, SB1-0, SB2-0, SB3-0, SB4-0, SB5-0, SB6-0 and SB7-0) is used to make up the RAID 5, 7+1 group, and any StorBrick were to fail, only one drive of that group would be affected. The RAID 5 algorithm would be able to recover the data from the remaining drives and the RAID group would remain available. Configurations varies based on needs for capacity versus protection.

There is also the option to assign both a RAID group dedicated spare drive or a global spare drive. For example, a RAID 5 group could be a 6+1 with a dedicated spare drive. In a full up system you would have 9 sets of these RAID groups, all spread across the StorBricks. One method for greater capacity is available by configuring 8 groups of 7+1, one group of 6+1 and a global spare. In a RAID 6 6+2, a spare may not be desirable at all, as one is already part of the group automatically. For configurations that maximize storage, can allow unavailability of data for a time and/or predict a high-success rate for StorBricks, very large RAID groups may be desirable. For typical RAID usage, RAID 5 7+1 or RAID 6 6+2 are most likely.

Warning: Do not configure multiple drives in a RAID group to be on the same StorBrick.

Since there are eight StorBrick in the MIS-Server, each with nine drives, the highest availability for the data would be RAID groupings that span the StorBricks. For example, a RAID 6 configuration should have eight drives, one from each StorBrick. In this configuration, if a StorBrick failed, the data would still be available. For RAID 5 or RAID 6, with one drive per StorBrick in a group, the loss of a StorBrick (SB3) does not affect the availability of the data (Figure 3-78).

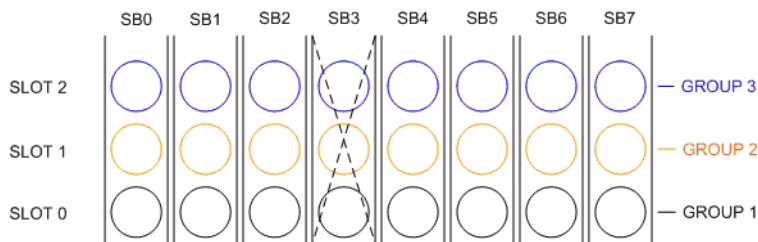

Figure 3-78 RAID 5 or 6 with one drive per StorBrick

If a larger RAID group is desired, it would have to have multiple drives on a StorBrick. Then if a StorBrick were to fail, two drives would be unavailable. If this were a RAID 6 implementation, the data would still be available, though another StorBrick failure or even a drive failure in that group would cause a loss of data availability. If this were a RAID 5 implementation, the data would become unavailable until the failed StorBrick is replaced (Figure 3-79).

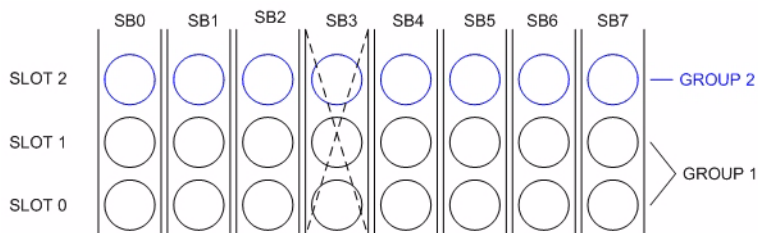

Figure 3-79 Loss of a drive with multiple drives on a StorBrick does not affect RAID 6, but will impact RAID 5

For RAID 6 with three drives of the group spanning a StorBrick, the data is unavailable until the failed StorBrick is replaced (Figure 3-80).

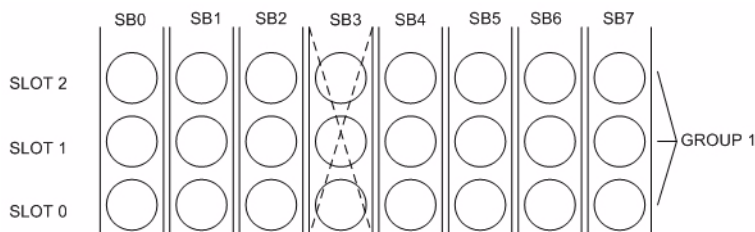

Figure 3-80 Three drive loss in RAID 6 require StorBrick replacement

For more on RAID configuration, see the MegaRAID guides on servinfo (<http://servinfo.com/>) or the Technical Publications Library (<http://docs.sgi.com>). Operating System software RAID support: Windows Dynamic Disks, Linux mdadm, or RAID-Z.

System Maintenance

For warranty and safety considerations, SGI designates the following chassis components as customer-replaceable units (CRUs):

- Power supplies
- Fans
- Disk drives

These components are all hot-swappable; that is, you can replace them without powering down the storage server. A trained service technician should install and replace all other components. This chapter describes how you replace the CRUs and check the system airflow:

- “Detecting Component Failures” on page 134
- “Sliding the Chassis Forward/Backwards” on page 134
- “Removing the Front or Rear Chassis Cover” on page 134
- “Replacing a Power Supply” on page 135
- “Replacing a Fan Module” on page 136
- “Replacing a Disk Drive” on page 137
- “Checking the System Air Flow” on page 140

Tools Required: The only tool you will need to perform maintenance is a #1 and #2 Phillips screwdriver.



Warning: Review the warnings and precautions listed in, “Important Information” on page xix, before setting up or servicing this chassis.

Detecting Component Failures

In general, when a system component fails, the operating system/storage management system (OS/SMS) receives an alert. The OS/SMS generates an alert to the monitoring application for your storage server. The alerts include the system serial number, the suspect component, and a summary of the fault. For most components, you should inform SGI service of the fault and forward the information from the alerts.

In addition to the alerts, the control panel on the chassis front panel can indicate component failures in the case of power supplies, fans, and drives. See Chapter 2, “System Interfaces”.

For more information about alert generation and management, see “Power Supply LEDs” on page 29.

Sliding the Chassis Forward/Backwards

The cable management system of the MIS chassis allows it to be slid forward (20") or backwards (18"). You will need to slide the chassis out to service some of its components. To slide the chassis out, follow these steps:

1. Push the two release latches in, at the front and rear, towards the center of the chassis.
2. Pull the chassis out using the handles. The chassis will latch at the 20- or 18-inch limit.
3. To slide the chassis back in, depress the two release latches near the rail and slide it back in.

Removing the Front or Rear Chassis Cover

Important: When a chassis cover is removed, an intrusion sensor monitored by the SMS will detect its removal. If the cover is off for more than 15 minutes or any system temperature sensor exceeds its threshold limit, the server will perform an orderly shutdown and power-off.

As shown in Figure 4-1, the top of the chassis is bifurcated; that is, there is a front and rear chassis cover. Except for power supply maintenance, all service actions require that you remove the front or rear chassis cover. This section describes the steps.

1. To remove a chassis cover, first follow the instructions in “Sliding the Chassis Forward/Backwards” on page 134.
2. Remove the single security screw from the cover.
3. Push the detent, and slide the cover out and up from the chassis.

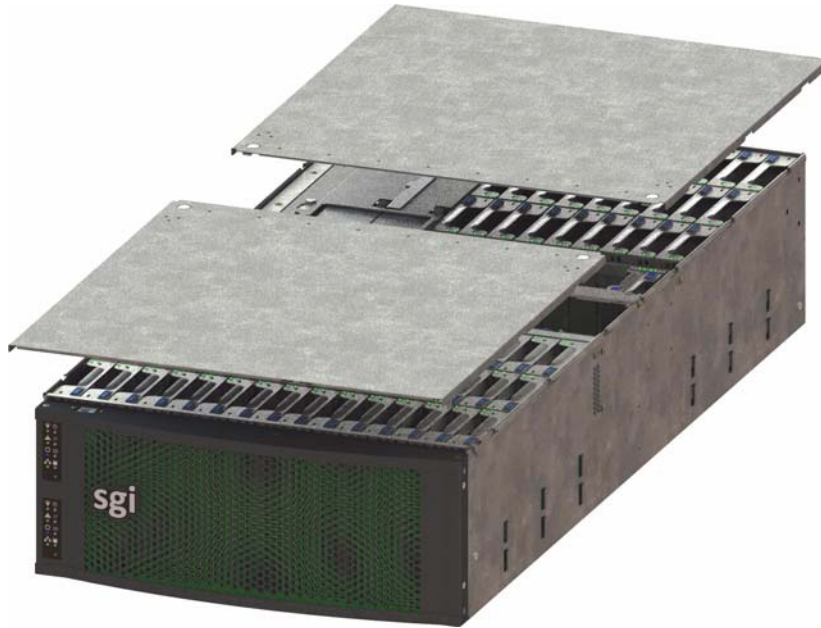

Figure 4-1 Front & Rear Chassis Covers

Replacing a Power Supply

To replace a failed power supply, do the following:

1. Using the OS/SMS interface for your system, verify the fault (failed unit) and its location.
2. Locate the failed unit: it should have a lighted yellow service LED. See Figure 4-2.
3. Unplug the power supply that will be replaced.
4. Push the release tab on the back of the power supply.
5. Pull the power supply out using the handle.

6. Replace the failed power module with another of the same model.
7. Push the new power supply module into the power bay until it clicks into the locked position.
8. Plug the AC power cord back into the module and power up the server.
9. Once power supply is verified good, clear the service required status via the OS/SMS interface.

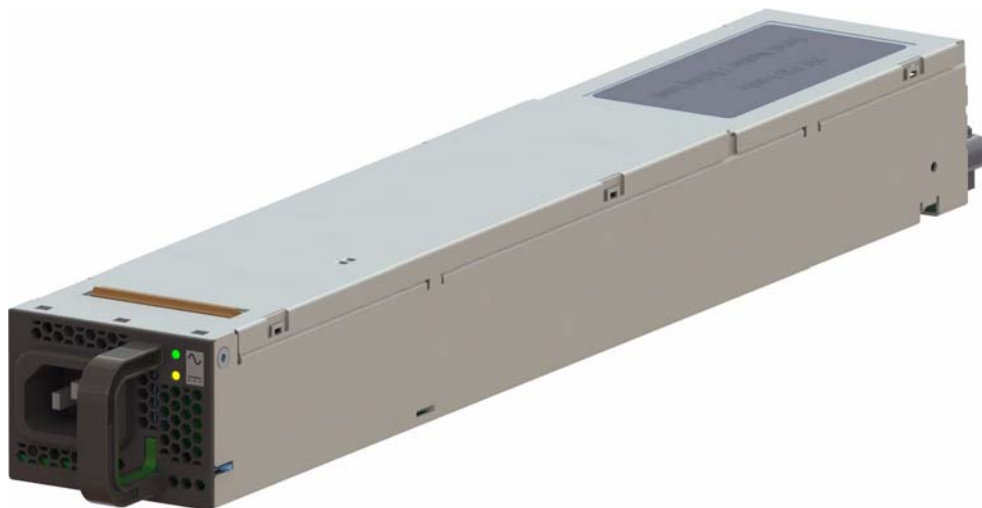

Figure 4-2 Replacing a Power Supply

Replacing a Fan Module

To replace a fan module, do the following:

1. Using the OS/SMS for your system, verify the fault (failed unit).
2. Using the OS/SMS, set the system to a service state for the removal of the faulted fan. The OS/SMS will turn off the fan module. It will then turn on the locator LED (blue) for that fan module.
3. Remove the front chassis cover. (See “Removing the Front or Rear Chassis Cover” on page 134.)
4. Locate the fan module with the illuminated blue LED (Figure 4-3).



Figure 4-3 Replacing a Fan Module

5. Loosen the thumbscrew, pull out the faulted fan by pulling upward on both the front and rear flanges, and replace it.
6. Once the fan module is replaced, seat the fan by pushing between the two leds until it seats.
7. Re-install the chassis cover and security screw.
8. Unlock the chassis from the extended position and push it back until it locks into the stowed position.
9. Using your OS/SMS, return the system to a normal state and the new fan module will be powered on.

Replacing a Disk Drive



Important: Empty drive carriers cannot be inserted into the storbricks, so slots without HDDs will not have carriers.

To replace a failed disk drive:

1. Using the OS/SMS for your system, verify the fault (failed unit).
2. Using the OS/SMS, set the system to a service state for the removal of the faulted drive. The OS/SMS will turn off the drive. It will then turn on the locator LED (blue) for that drive.
3. Remove the chassis cover. (See “Removing the Front or Rear Chassis Cover” on page 134.)
4. Locate the faulted drive with the illuminated blue LED and remove it from its StorBrick (or boot drive bay). (See “Removing the Drive” on page 138.)
5. Replace the faulted drive. (See “Re-installing the Drive” on page 139.)
6. Once the drive is replaced, re-install the chassis cover and security screw.
7. Unlock the chassis from the extended position and push it back until it locks into the stowed position.
8. Using the OS/SMS, return the system to a normal state. The new drive will be powered on.
9. Using the OS/SMS, clear the service required status. At this time the rebuild or mirroring of the data to the new drive will begin.

Removing the Drive

As shown in Figure 4-4, the drives are mounted in driver carriers to simplify their installation and removal from the drive bricks or boot drive bays in the chassis.

To remove the drive, perform the following steps:

1. Ensure that the drive LEDs are off (except the blue locator LED), indicating that the drive is not in use and can be removed.
2. Unlatch the drive carrier by sliding the grey latch toward the drive and pull the drive carrier out of the StorBrick or boot drive bay.
3. Remove the four screws that secure the drive to the drive carrier.
4. Remove the drive from the carrier.

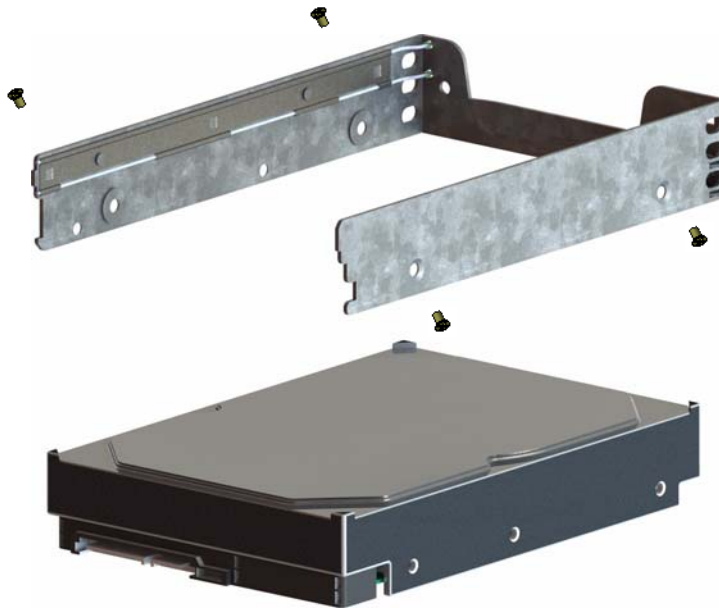

Figure 4-4 Hard Drive Carrier

Re-installing the Drive

To re-install a hard drive into the hard drive carrier, perform the following steps:

1. Place the hard drive carrier on a flat, stable surface such as a desk, table, or work bench.
2. Slide the hard drive into the carrier with the printed circuit board side facing down.
3. Carefully align the mounting holes in the hard drive and the carrier.
Make sure the bottom of the hard drive and bottom of the hard drive carrier are flush.
4. Secure the hard drive using the four screws (see Figure 4-4).
5. Replace the drive carrier into the chassis.
6. Push the drive carrier down to lock it place.

Checking the System Air Flow

To check the air flow for an MIS enclosure, perform the following steps:

1. Remove the chassis cover. (See “Removing the Front or Rear Chassis Cover” on page 134)
2. Remove the midspan: unscrew the Phillips screws from either end of the brace, and lift away the brace.
3. Make sure there are no objects wires or foreign objects obstruct air flow through the chassis. Pull all excess cabling out of the airflow path.

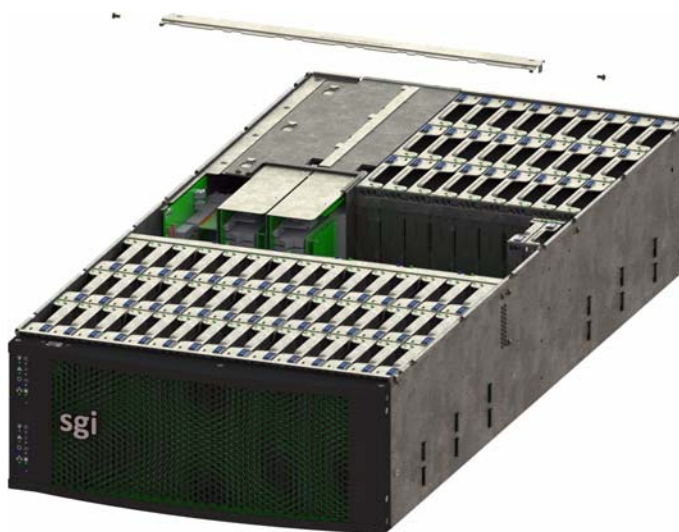

Figure 4-5 MIS Chassis Midspan Support Brace

Troubleshooting

This chapter describes troubleshooting for the problems listed below. Chapter 2, “System Interfaces,” describes use of the control panel to monitor the overall system status and the status of specific components. Chapter 4, “System Maintenance,” describes how to replace defective components.

- “No Video” on page 141
- “Losing the System’s Setup Configuration” on page 141
- “I/O Time-outs and MegaRAID Drivers” on page 142
- “Safe Power-Off” on page 142

For help beyond what is mentioned in this document, see “Product Support” on page xxv.

No Video

If the power is on but there is no video, remove all add-on cards and cables. Use the speaker to determine if any beep codes exist. Refer to Appendix B, “BIOS Error Codes” for details.

Losing the System’s Setup Configuration

Make sure that you are using a high quality power supply. A poor quality power supply may cause the system to lose the CMOS setup information. If this does not fix the Setup Configuration problem, contact your vendor for repairs.

I/O Time-outs and MegaRAID Drivers

To avoid I/O time-outs with certain workloads, the `megaraid_sas` driver needs to have the `poll_mode_io` variable set to 1. For Novell operating systems on SGI InfiniteStorage servers, the file `/etc/modprobe.conf.local` needs the following line added:

```
options megaraid_sas poll_mode_io=1
```

This modification will be made on systems shipped from the factory, but if a system is installed or upgraded in the field, this change will have to be made after installation/upgrade.

Safe Power-Off

There are several safe power-off methods for an MIS Server or JBOD. They include,

- Using the OS GUI power-off button at the console screen, if a keyboard/mouse/video monitor is connected.
- Pushing and holding the Power button on the front panel (see Figure 2-1 on page 26).
- When logged in via an ssh session and executing a “shutdown” or “poweroff” command.
- When logged in to the BMC and using the power control page to power off the sever.
- Using the remote console screen GUI power-off button, if a KVM RMM4Lite session is established through the BMC.

If the platform is an MIS dual-server and both servers are powered up, performing the above steps only powers off the server with which you are working. The fans, drives and second server will remain powered on until the second server is powered off, then all power (but standby) will be turned off.

For a JBOD Unit, the power button on the front panel will turn off the power to that I/O module. If a second module is installed and powered on, it, the fans and the drives will remain on until it, too, is powered off.

Technical Specifications

Table A-1 describes the technical specifications for the SGI MIS platform.

Table A-1 Technical Specifications

Attribute	Specification
Overview	
Profile	4U Standard-depth chassis
Product type	SGI MIS Server Platform (single or dual server), or SGI MIS JBOD Unit
Connectivity	Up to four SGI MIS JBOD units per SGI MIS Dual Server
Mount	<ul style="list-style-type: none"> –Standard 19-inch rack-compatible rail mount (weight-dependent) –SGI 19-inch Destination Rack (D-Rack), 42U –Up to 10 chassis per D-Rack
Chassis Dimensions	
Height	6.94" (176 mm)
Width	16.9" (429.2 mm)
Depth	36" (914.4 mm)
Max weight	220 lbs.
Power	
AC Input	100–240 VAC (50-60Hz), single or three phase
Safety	<ul style="list-style-type: none"> –UL/CSA certified to UL6050-1 –CE/CB certified to EN60950/IEC60950
EMC	<ul style="list-style-type: none"> –North America FCC Class A –Europe EN55022/EN55024
Operating Environment	

Table A-1 Technical Specifications (continued)

Attribute	Specification
Operating temperature range	–41° to 95° F (5° to 35° C) –processor cores automatically allowed to run faster than the base operating frequency, if the cores are operating below power, current, and temperature specification limits (< 35°C ambient)
Non-operating temperature range	–40° to 140° F (minus 40° to 60° C)
Operating humidity range	10% to 90% non-condensing
Non-operating Humidity	10% to 95% non-condensing
SGI MIS Server Specifications	
Servers/System	–One or two server modules per system –Single- or dual-socket processors per server
Processor support	–Supports Intel® Xeon® E5-2600 series processors –Supports Intel Turbo Boost Technology 2.0
Max cores	16 per server (32 per system)
Memory	–Up to 8 DDR3 DIMMs (4 GB, 8 GB, or 16 GB) for a single-server motherboard configuration –Up to 16 DIMMs for a dual-server motherboard configuration. –Max 128GB per server
Boot drives	–Two per server, mirrored using RAID 1 –3.5" or 2.5" (15mm or 9.5mm) –SAS or SATA –Rotational or SSD –Up to 300 GB
Supported operating systems	–RHEL 6.2 –SLES 11 SP1 –VMware ESX 5.0 –Windows 2008 R2 SP1
Networking	Up to four user-specified PCIe HBAs, full-height (4.25") and half-depth (3.375"), externally or internally facing

Table A-1 Technical Specifications (continued)

Attribute	Specification
Expansion slots	Single server: 6 x PCIe gen 2 Dual server: 4 x PCIe gen 2 per server (8 total)
RAID controllers	-8 to 32 SAS ports via 8-port PCIe cards -Support for RAID 0, 1, 5, 6, 00, 10, 50, and 60
External storage attachment	Up to 4 SGI MIS JBOD Units via PCIe cards
Internal storage	-Up to 81 SAS or SATA 15mm, 2.5" or 3.5" drives -Up to 162 SAS or SATA 9.5mm, 2.5" drives -Drive size and capacity can be mixed in groups of 8 -Supported internal drives: SAS or SATA, rotational or SSD
SGI MIS JBOD Specifications	
Internal Storage	-Up to 81 SAS or SATA 15mm, 2.5" or 3.5" drives -Up to 162 SAS or SATA 9.5mm, 2.5" drives -Drive type and size can be mixed in groups of 9 -Supported internal drives: SAS or SATA, rotational or SSD
Connectivity	8 or optional 16 SAS ports

BIOS Error Codes

The BMC may generate beep codes upon detection of failure conditions. Beep codes are sounded each time the problem is discovered (for example, on each power-up attempt) but are not sounded continuously. Common supported codes are listed in Table B-1.

In Table B-1, each digit in the code is represented by a sequence of beeps whose count is equal to the digit.

Table B-1 BMC Beep Codes

Beep Code	Reason for Beep	Associated Sensors	Supported
1-5-2-1	No CPUs installed or first CPU socket is empty.	CPU Missing sensor	Yes
1-5-2-4	MSID Mismatch.	MSID Mismatch sensor.	Yes
1-5-4-2	Power fault: DC power is unexpectedly lost (power good dropout).	Power unit—power unit failure offset.	Yes
1-5-4-4	Power control fault (power good assertion time-out).	Power unit—soft power control failure offset.	Yes
1-5-1-2	VR Watchdog Timer sensor assertion	VR Watchdog timer	
1-5-1-4	The system does not power on or unexpectedly powers off and a power supply unit (PSU) is present that is an incompatible model with one or more other PSUs in the system.	PSU status	

Zone Permission Groups Rules

There three group controls within the expanders that must be set. These are **Allow Broadcast**, **Allow Zoning and Phy (Physical) Changes**, and **Unassigned Slot Group**. The **Allow Broadcast** bit is set to that the sever can send and receive broadcasts. The **Allow Zoning and Phy Changes** bit is set so that hot-swapping drives is allowed. The **Unassigned Slot Group** bit is set so that drives that are yet to be zoned are still recognized by the system.

The first 8 bits are the Master Group. The first bit (0) has access to bit 1 and nothing else. This is why the Master Group 0 is always set to 0, to avoid an extra step. Master Group 1 is all FF—it “sees” everyone. Master Groups 2 & 3 talk to all the Initiators (bits 8-15), and currently, Master Groups 4-7 point up to Master Group 1 (this may change in the future).

The next 8 bits are the Initiator Groups. Bit 8 through 11 corresponds to Adapter 1, Paths 0 through 3 and bits 12-15 correspond to Adapter 2, Paths 4 through 7. The next 16 through 24 bits are the zone permission groups, with the 25th bit always set for the unassigned slot. The remaining bits are reserved for future use. See Figure C-1 and Figure C-2 for examples.

