

Abstract

This guide was written with the goal of describing the basic setup and troubleshooting steps required for integrating the MLX90393 Triaxis™ device in an application. A simple rotary sensing application is used as an example.



Applicable Applications

All rotary, linear, and joystick applications using the MLX90393.

Recommended Tools and Resources

[MLX90393 Datasheet](#)

Oscilloscope or I2C->PC adaptor with I2C decoding

MLX90393 EVB (evaluation board) and MBED LPC1768 board

Convention, Acronyms, and Abbreviations

Number Format and Text

Values in hexadecimal are shown with a preceding "0x". For example: 0x12 is decimal 18.

Binary values are shown with a preceding "0b". For example: 0b10010 is decimal 18.

Textual descriptions are shown in this format

Code examples are shown in this format

[Warnings and cautions are shown in this format](#)

Acronyms

SDA = Serial Data Line

SCK = Serial Clock Line

V_{DD} = Analog Supply

V_{DD_10} = Digital Supply

MSb = Most Significant Bit

LSb = Least Significant Bit

MSB = Most Significant Byte

LSB = Least Significant Byte

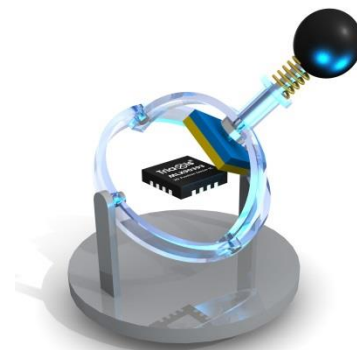
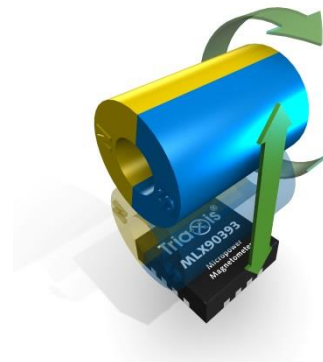
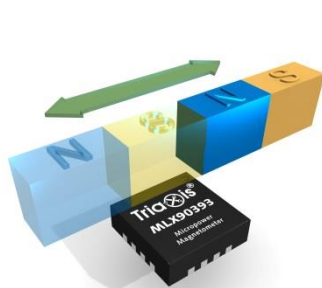

Table of Contents

Abstract.....	1
Applicable Applications.....	1
Recommended Tools and Resources	1
Convention, Acronyms, and Abbreviations	1
Number Format and Text	1
Acronyms.....	1
Table of Contents.....	2
Pinout.....	4
Axis Definition	5
Practical getting started.....	6
Practical getting started guide	7
MLX90393 interface library for mbed	7
CherryStone soft-and firmware releases & compatibility.....	8
Communication	9
I ² C Protocol.....	9
SPI Protocol	10
Memory Model	11
HALLCONF	11
GAIN_SEL	11
Z_SERIES	11
BURST_DATA_RATE	11
BURST_SEL.....	12
TCMP_EN.....	12
EXT_TRIG	12
WOC_DIFF	12
COMM_MODE.....	12
TRIG_INT_SEL	12
OSR	12
DIG_FILT	12
RES_XYZ.....	12
OSR2	13
SENS_TC_LT & SENS_TC_HT.....	13
OFFSET_X, OFFSET_Y & OFFSET_Z.....	13
WOXY_THRESHOLD, WOZ_THRESHOLD & WOT_THRESHOLD.....	13
Address 10-31.....	13
Key Commands	14

<i>CONTROL COMMANDS</i>	14
Exit (EX).....	14
Reset (RT)	15
<i>MEMORY COMMANDS</i>	15
Memory Store (HS).....	15
Memory Recall (HR).....	15
Read Register (RR).....	15
Write Register (WR).....	15
<i>MEASUREMENT COMMANDS</i>	15
Start Burst Mode (SB).....	15
Single Measurement (SM)	16
Read Measurement (RM)	16
Start Wake-up on Change (SWOC)	16
Application specific	17
Resolution.....	17
Calculation of conversion time.....	17
Sensitivity.....	18
Available hardware (EVB)	19
Example #1: Rotary Application.....	20
Magnetic Configuration.....	20
Suggested EEPROM Configuration	20
Rotary Code Example	21

Pinout

The pinout for the MLX90393 is below.

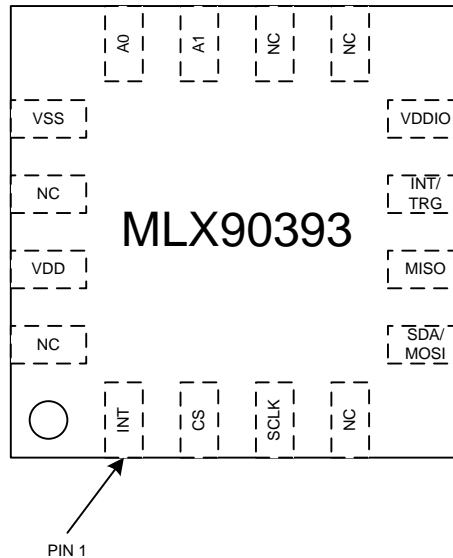

Figure 1: Pinout

Pin Number	Pin Name	Pin Function
1	INT	Data ready signal output pin, active high (DRDY flag)
2	CS	Chip select, used when communicating in SPI mode Pull high when in I2C mode
3	SCLK	Serial clock for both SPI and I2C mode
4, 9, 10, 14, 16	NC	-
5	SDA/MOSI	Data input pin in SPI mode, data input/output pin in I2C mode
6	MISO	Data output pin in SPI mode
7	INT/TRIG	Trigger pin, can be used to start measurement
8	VDDIO	Power supply for digital
11	A1	Bit 1 of the 7-bit I2C address (0 0 0 1 1 A1 A0)
12	A0	Bit 0 of the 7-bit I2C address (0 0 0 1 1 A1 A0)
13	VSS	Ground
15	Vdd	Power supply

Axis Definition

The axes of the MLX90393 are defined in the datasheet and are shown below.

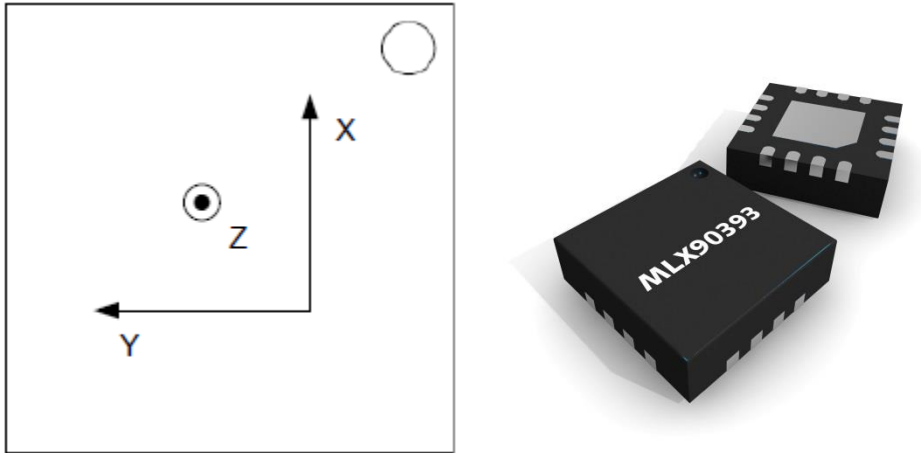

Figure 2: MLX90393 QFN Axis Definitions

Practical getting started

Legend:

- Software
- Firmware
- Communication

Getting Started in practice

Host PC/ Laptop

- Download LabVIEW Run-Time Engine (12.0) → install
- Download NI-VISA Driver (5.0.3) → install
- Download MBED USB-driver → install (connect mbed)

Mbed LPC1768

- Download MBED -Firmware → upload to mbed and reset

MLX90393

- Make physical connections between PC,MBED and MLX90393

Host PC/Laptop

- Download CherryStone.exe → install and run

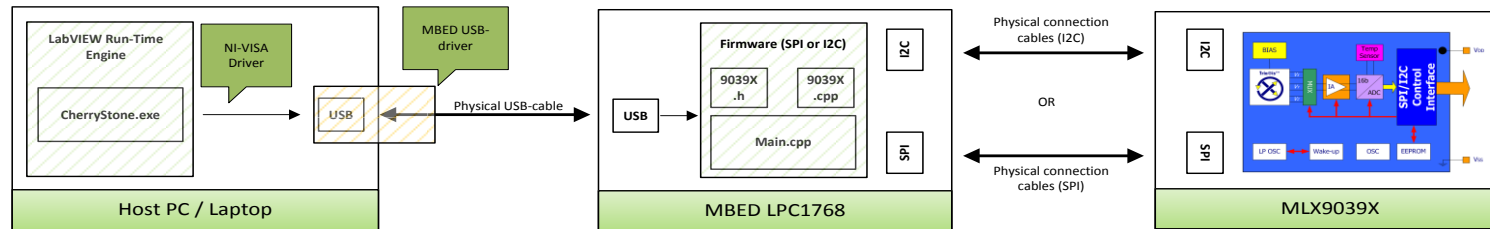
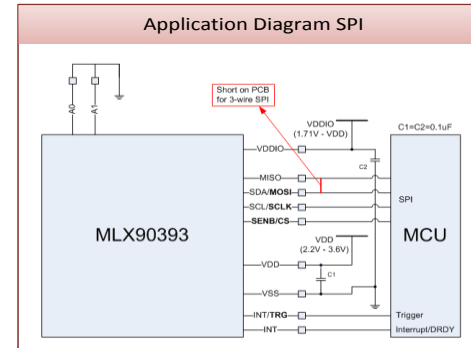
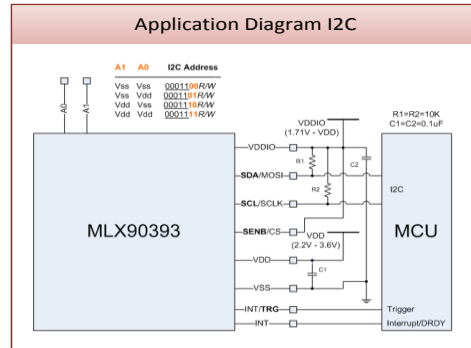

Implementation / Installation sequence

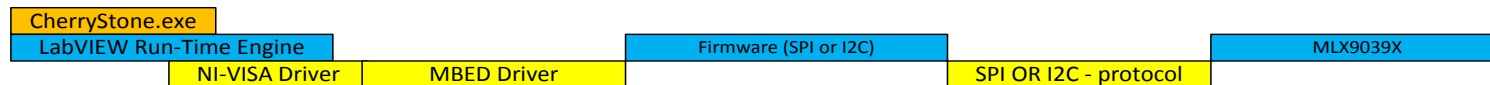

Practical getting started guide

1. NI LabView Runtime Engine

A first step before installing the CherryStone executable is installing LabVIEW Run-Time Engine 12.0. This software can be downloaded directly from National Instruments website.

32-bit version: Click [here](#)
<http://www.ni.com/download/labview-run-time-engine-2012/3433/en/>

2. NI VISA-driver

Visa Driver: Click [here](#)
<http://www.ni.com/download/ni-visa-run-time-engine-5.0.3/2257/en>

3. MBED driver

Make sure your mbed is connected while executing this step

Mbed Driver: Click [here](#)
http://developer.mbed.org/media/downloads/drivers/mbedWinSerial_16466.exe

4. CherryStone Software Executable

CherryStone (= the interface program, refer to diagram shown earlier in this document): Click [here](#)

5. MBED firmware

MBED SPI firmware: Click [here](#)
MBED I²C firmware: Click [here](#)

Upload the firmware to mbed:

- Connect your mbed to your PC/laptop - a new drive called "MBED" should appear.
- Download the firmware from the Melexis website (either SPI, or I2C) and drag and drop the file directly into the drive".
- Once the bin-file is uploaded, the mbed must be reset by pressing the push button at the center of the mbed.

MLX90393 interface library for mbed

Sample code and a complete library holding all MLX90393's functions are written for [mbed](#) and can be downloaded from www.mbed.org/teams/melexis or directly from our website

The MBED used at Melexis is the [LPC1768](#). Please note that the firmware BIN files made available have been compiled for this specific MBED hardware. When using other MBED devices, or other microcontrollers in general, the source code is recommended as a starting point for software development.

CherryStone soft-and firmware releases & compatibility

Date	CherryStone.exe	CherryStone.bin
January 2015	CherryStone 3	CherryStone3_I2C(SDA = p9, SCL = p10, A1=p21, A0=p22).bin CherryStone3_SPI(MOSI =p5, MISO = p6, CLK= p7, CS=p8).bin

Communication

The MLX90393 can be used with either an SPI or an I2C bus. The use of both protocols will be explained in the next sections. This user guide gives a brief introduction to our user interface tool for quick ‘plug and play’ solutions that enables you to communicate with the MLX90393 without having to make the effort of implementing the communication protocol yourself.

I²C Protocol

One initial hurdle with starting work with the MLX90393 is configuring the I²C bus correctly. The clock frequency can be set between 10kHz (low-speed mode), 100kHz(standard mode), 400kHz (Fast mode). Every I²C device on the bus must also be assigned an address. The two LSB’s of the MLX90393 I²C address can be selected via the A0 and A1 pins allowing for four different addresses. In this document it is assumed that the A0 and A1 pins are shorted to ground. This results in an I²C address of 0x19 (for MBED, in other environments this might be defined in another way).

The 7 bit I²C address in MBED is defined as follows as a byte:

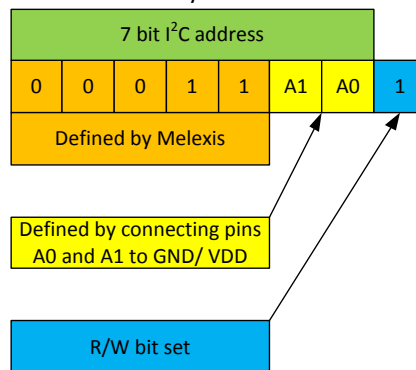

Figure 3: MBED I²C address definition

The orange section is set in the NVRAM of the IC, the yellow section depends on how pins A0 and A1 are connected. The last bit should be set for the MBED, no matter if one reads or write to the IC. The MBED will send on the bus the correct R/W bit automatically.

The MLX90393 operates on a command / response configuration and can be broken down into two sequences:

Command Write and **Response** Read.

Command Write:

To initiate a communication sequence the master addresses the slave with the write bit set. If the MLX90393 recognizes the address it responds with an ACK. The master then issues the command to the MLX90393. If accepted, the MLX90393 responds with another ACK.

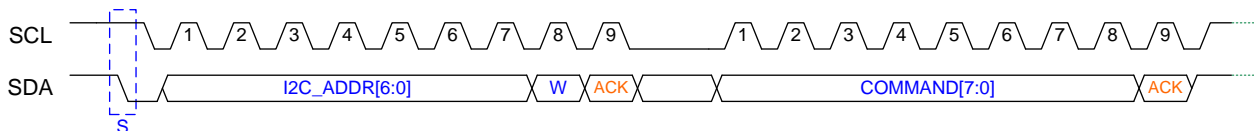

Figure 4: Sending an I²C command

Response Read:

To read back the response the master addresses the MLX90393 with the R bit set. The master then sends enough clock pulses to clock out all the required data bytes. The number of data bytes depends on the command transmitted

and can range from zero (eg: NOP message) to eight (eg: measurement with all axes, temp, and a status byte). The number of data bytes is indicated in the status byte which is always the first byte read out from the MLX90393.

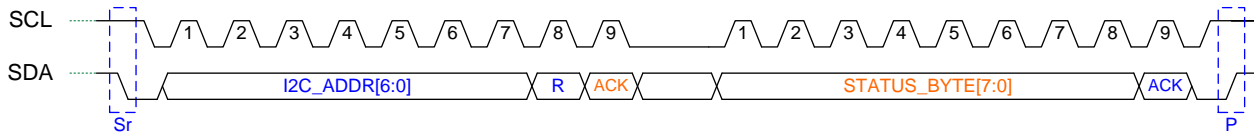

Figure 5: I²C readback of status byte

Note: Failure to readdress the slave after the Command Write will result in the transaction failing.

SPI Protocol

One initial hurdle with starting work with the MLX90393 is configuring the SPI bus correctly. The chip can handle clock frequencies up to 10MHz. The SPI communication is implemented in a half-duplex way, showing high similarities with the I²C communication. Addressing on the bus is done through the $\overline{\text{CS}}$ instead of physical addresses. Both three- and four-wire SPI is possible (three wire by shorting the MISO and MOSI). SPI mode 3 is implemented: CPHA=1 (data changed on leading edge and captured on trailing edge, and CPOL=1 (high level is inactive state). The Chip Select line is active-low.

The MLX90393 operates on a command / response configuration and both are sequentially done in one go in SPI.

The communication is also bundled in bytes, equally MSB first and MSByte first. A command can of course consist of more than 1 byte as can the response be from the MLX90393 in the form of multiple bytes after the status byte. Figure 6 shows an example of an SPI command being followed by the readback of the status byte.

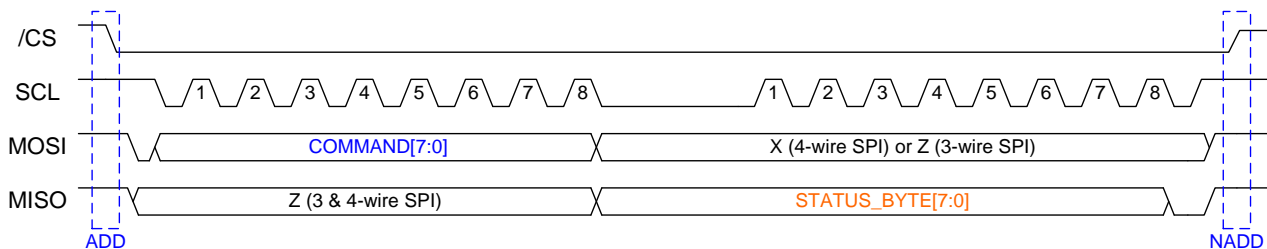

Figure 6: SPI example

Memory Model

As the code example will be modifying the register contents it is useful to review the memory model of the MLX90393. It operates with a dual memory model consisting of volatile and nonvolatile areas. During operating conditions the values in the volatile memory are used and are loaded from nonvolatile memory at power up or when a recall command is issued. It is necessary to know that if the write register command is issued this affects the volatile memory only. A store command is needed to permanently store the modifications. Refer to the datasheet for more details. The first 32 addresses are programmable by the user.

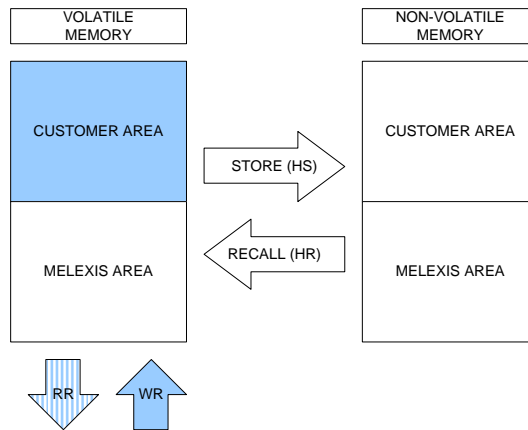

Figure 7: Memory model

	15	14	13	12	11	10	9	8	7	6	5	4	3	2	1	0
0	RESERVED_LOW								Z_SERIES	GAIN_SEL			HALLCONF			
1	TRIG_INT_SEL	COMM_MODE		WOC_DIFF	EXT_TRIG	TCMP_EN	BURST_SEL			BURST_DATA_RATE						
2	RESERVED			OSR2	RES_XYZ				DIG_FILTER		OSR					
3	SENS_TC_HT						SENS_TC_LT									
4	OFFSET_X						OFFSET_Y									
5	OFFSET_Z						WOXY_THRESHOLD									
6	WOZ_THRESHOLD						WOT_THRESHOLD									
7	WOT_THRESHOLD															
8																
9																

Figure 8: Memory map of customer area

HALLCONF

Spinning and chopping rate adjustment.

HALLCONF[3:2] defines the duration of one Hall plate spinning phase in clock cycles: $\#clocks/spinning_phase = 8 * 2^{HALLCONF[3:2]}$. Default this value is 3.

HALLCONF[1:0] defines the number of amplifier chopping periods inside one spinning phase: $\#chopping_periods/spinning_phase = 2^{HALLCONF[1:0]}$. Default this value is 0.

The default HALLCONF is 0xC.

GAIN_SEL

Selection of the gain, adjustable from 0 to 7. See sensitivity table for sensitivity of the IC in LSB/G for each setting of the gain and the resolution.

Z_SERIES

Connection of the Hall plates for Z-axis measurements. Recommended setting: 0x0.

BURST_DATA_RATE

This parameter controls the data rate in burst mode and in WOC mode. The rate is defined as the time between the end of one measurement and the start of a new measurement, regardless of the fact if the data is read out or not. A

value of 0x0 means a continuous burst mode, other value encode as follows: interval = 20ms * BURST_DATA_RATE. The max is 0x3F, corresponding to 1260ms. This interval can be observed by looking at the DRDY flag.

BURST_SEL

This parameter determines the measurements (X, Y, Z and Temp, or any combination of them) to be performed in the case that the SB or SWOC command did not specify the measurements. The bit order is (from MSB to LSB): ZYXT.

TCMP_EN

Enables the temperature compensation. Please refer to the application note on the temperature compensation for more info.

EXT_TRIG

When this bit is set, the external pin INT/TRIG can be used to start a measurement. This only works when TRIG_INT_SEL is not set (digital input). Otherwise, changes at this pin will be ignored. The axes to be measured are specified by BURST_SEL.

WOC_DIFF

Absolute or derivative WOC mode:

If 0, an absolute mode is used. Measurements are compared to the first measurements;

If 1, a relative mode is used. Measurements are compared to the previous ones.

COMM_MODE

Defines the communication mode. If it is 0x0 or 0x1, the IC can be used both by I2C and SPI. If 0x2, only SPI can be used and if 0x3 only I2C can be used.

TRIG_INT_SEL

Selects the function of the INT/TRIG pin. When set, the pin is used as digital output, otherwise it is an input.

OSR

Defines the oversampling rate of the ADC decimation filter for magnetic measurements. $OSR_ADC = 64 * 2^{OSR}$. This will directly impact the measurement time for magnetic measurements.

Note: The chip will not work properly with the following combinations: OSR=0 and DIG_FILT=0, OSR=0 and DIG_FILT=1 and OSR=1 and DIG_FILT=0

DIG_FILT

A control for the digital filter. An averaging over a certain amount (2^{DIG_FILT}) will be done. This will directly impact the measurement time for magnetic measurements.

Note: The chip will not work properly with the following combinations: OSR=0 and DIG_FILT=0, OSR=0 and DIG_FILT=1 and OSR=1 and DIG_FILT=0

RES_XYZ

This 6 bit parameter consists out of three parts, one for each axis. **The two MSBs act on the Z-axis, the 2 LSBs on the X-axis and the middle 2 bits on the Y-axis.** Internally each magnetic measurement is 19 bits long. On the output, only 16 bits can be read out. This parameter selects for each axis which 16 bits to read out. Please refer to section **Error! eference source not found.** for further detailed information.

OSR2

Defines the oversampling rate of **the ADC decimation filter for a temperature measurement**. $OSR_ADC = 64 * 2^{OSR}$. This will directly impact the measurement time for the temperature measurement.

SENS_TC_LT & SENS_TC_HT

These parameters are used for the **temperature compensation** for the sensitivity drift of the Hall elements. SENS_TC_HT is the parameter for temperatures **above 35 degC**, SENS_TC_LT is the parameter for temperatures **below 35 degC**. Please refer to the application note on the temperature compensation for more info. These values can be blindly programmed to the values given in this document (if not already programmed).

OFFSET_X, OFFSET_Y & OFFSET_Z

These parameters are used **to compensate the offset in case the temperature compensation is enabled**. They are **not used with TCMP disabled**. Please refer to the application note on the temperature compensation for more info. These values can be blindly programmed to the values given in this document (if not already programmed).

WOXY_THRESHOLD, WOZ_THRESHOLD & WOT_THRESHOLD

Defines the wake up thresholds on X, Y, Z axis or on temperature. The resolution of the temperature sensor is 45.2LSB/K.

Address 10-31

Address 10 to 31 are free to use by the customer. For example traceability information could be stored in here.

Key Commands

Table 1 shows an overview of all commands possible with the MLX90393. The amount of bytes to be sent and read back is different for each command. In case more bytes are needed, first byte #1 is sent, then byte #2 and so on.

Table 1: Commands overview

Command	Symbol	CMD byte #1	CMD byte #2	CMD byte #3	CMD byte #4	# bytes to read back
EXit	EX	1000 0000	-	-	-	1 (status)
Start Burst mode	SB	0001 zyxt	-	-	-	1 (status)
Start Wake-up On Change	SWOC	0010 zyxt	-	-	-	1 (status)
Start Measurement (polling mode)	SM	0011 zyxt	-	-	-	1 (status)
Read Measurement	RM	0100 zyxt	-	-	-	1 (status) + 2*[z+x+y+t] (data)
Read from a Register	RR	0101 0000	A[5:0] << 2	-	-	1 (status) + 2 (data)
Write from a Register	WR	0110 0000	D[15:8]	D[7:0]	A[5:0] << 2	1 (status)
Reset	RT	1111 0000	-	-	-	1 (status)
Memory Recall	HR	1101 0000	-	-	-	1 (status)
Memory Store	HS	1110 0000	-	-	-	1 (status)
No OPeration	NOP	0000 0000	-	-	-	1 (status)

All commands will return a status byte showing the current state the IC is in. The 8 bits out of which the status byte consists are explained below:

Bit 7	Bit 6	Bit 5	Bit 4	Bit 3	Bit 2	Bit 1	Bit 0
Burst_mode	WOC_mode	SM_mode	ERROR	SED	RS	D1	D0

Figure 9: Status byte

- Burst_mode: if set, the IC is working in burst mode.
- WOC_mode: if set, the IC is in wake-up-on-change mode
- SM_mode: if set, the IC is executing a measurement sequence in polling mode. It can be initiated by a SM command or a pulse on the TRIG input
- ERROR: indicates an error. Can be set when reading out a measurement while the measurement is not yet completed or when reading out the same measurement twice.
- SED: indicates that a single bit error has been corrected by the NVRAM
- RS: indicates that the device has been reset successfully by a reset command.
- D1-D0: indicates the number of bytes (2D[1:0]) to follow the status byte after a read measurement or a read register command has been sent.

CONTROL COMMANDS

Exit (EX)

The exit command is used to force the IC into idle mode. The command will be used to exit the burst mode and the wake-up-on-change mode. During a single measurement in polling mode, the command is rejected. The status byte will then show an error and indicate that the IC is in polling mode (SM_mode).

Reset (RT)

This command is used to reset the IC. On reset, the idle mode will be entered again. The status byte will reflect that the reset has been successful.

MEMORY COMMANDS

Memory Store (HS)

If the HS command is used, the content from the volatile RAM is overwritten in the non-volatile RAM. On the next reset, this content will be loaded into the volatile RAM.

Warning: To reliably store the register it is required to supply the IC with 3.3V (VDD)

Memory Recall (HR)

If the HR command is used, the content from the non-volatile RAM is overwritten in the volatile RAM. The same is automatically done at start-up.

Read Register (RR)

The RR command is used to read out the content of one specific address of the volatile RAM. The address ranges from 0 to 63. Remind that the last 32 addresses are MLX area which cannot be changed by the user. They are read-only. Note that in **the command, the address will be sent as if it is multiplied by 4** (shifted two bits).

Write Register (WR)

The WR command is used to write directly in the volatile RAM. The address ranges from 0 to 63. Remind that the last 32 addresses are MLX area which cannot be changed by the user. They are read-only. Note that in the command, the address will be sent as if it is multiplied by 4 (shifted two bits). Always full words will be written. Words 0x00 to 0x09 are used to store operating parameters. Words 0x0A to 0x1F are free and usable to store any other data.

Warning: The WR command modifies volatile memory and changes will be lost upon a power cycle. If the modified values are required to be permanent then a memory store (HS) command must be issued after modifying the desired registers.

MEASUREMENT COMMANDS

These commands are used for doing measurements or are related to measurement based behavior. In all these commands, the first byte consists out of 4 bits that determine the command and 4 bits (4 LSBs) stating the stuff to be measured. In Table 1, these 4 LSBs are called z, y, x and t. By setting the correct bits, one can choose what information needs to be measured or read back. z, y and x stand for the magnetic fields in 3D, t is temperature. Disabling certain measurements will end up in a shorted measuring time.

Start Burst Mode (SB)

To start the burst measuring mode, this command will be used. It consists of a single byte with four user-defined bits: z, y, x, and t. These four bits determine which axes will be converted whenever they are set to a 1. Setting an axis to 0 results in the MLX90393 not performing a conversion on that axis and therefore yields a faster conversion cycle and reduced current consumption. When zyxt = 0x0, the SB command will enable the measurements specified by the NVRAM parameter BURST_SEL. The command will only be accepted in case the IC is not operating in another mode (WOC or SM mode). If this is the case, **the error flag is raised in the status byte**. In case the command is received successfully, the Burst_mode flag of the status byte will be set. After the measurement is complete, the DRDY flag is set (INT pin high). On the start of a new measurement, the DRDY flag is set low again, even if the previous measurement has not been read out.

Single Measurement (SM)

The single measurement command is used to instruct the MLX90393 to perform an acquisition cycle. It consists of a single byte with four user-defined bits: z, y, x, and t. These four bits determine which axes will be converted whenever they are set to a 1. Setting an axis to 0 results in the MLX90393 not performing a conversion on that axis and therefore yields a faster conversion cycle and reduced current consumption. When $zyxt = 0x0$, the SM command will enable the measurements specified by the NVRAM parameter BURST_SEL (like with SB command). The command will only be accepted in case the IC is not operating in another mode (WOC or burst mode). If this is the case, the error flag is raised in the status byte. In case the command is received successfully, the SM_mode flag of the status byte will be set. The next command following this command usually is RM. After the measurement is complete, the DRDY flag is set (INT pin high).

Read Measurement (RM)

The Read Measurement command is used to retrieve the data previously acquired by the SM or SB command. Similar to these commands, the RM command can also select which data is transmitted. Typically the value for z, y, x, and t will be the same as the SM command preceding the RM command.

The status byte received from the MLX90393 will indicate the number of data bytes waiting to be read out. In the case where all axes and temp are converted the number of bytes will be 8. The data is output in the following order: T (MSB), T (LSB), X (MSB), X (LSB), Y (MSB), Y (LSB), Z (MSB), Z (LSB)

If an axis wasn't selected to be read or converted then that value will be skipped in the transmission.

Start Wake-up on Change (SWOC)

If this command is sent, the WOC mode is entered. The IC will raise the DRDY flag (INT pin) when the thresholds are crossed specified by WOXY_THRESHOLD, WOZ_THRESHOLD and WOT_THRESHOLD. Both a differential mode and absolute mode is available (WOC_DIFF). For the differential mode, each change equal to the threshold after a RM command will be flagged. The x, y, z and t in the command specify which measurements should be done. When $zyxt = 0x0$, the SWOC command will enable the measurements specified by the NVRAM parameter BURST_SEL.

The status byte will show the WOC mode has been entered.

Application specific

Resolution

The resolution of the sensor can be changed by parameter RES_XYZ. This 6 bit parameter consists out of three parts, one for each axis. The two MSBs act on the Z-axis, the 2 LSBs on the X-axis and the middle 2 bits on the Y-axis. Internally each magnetic measurement is 19 bits long. On the output, only 16 bits can be read out.

By setting the resolution, one can choose which 16 bits to read out as follows (for 0G):

	18	17	16	15	14	13	12	11	10	9	8	7	6	5	4	3	2	1	0
Res = 0x3	0	1	0	0	0	0	0	0	0	0	0	0	0	0	0	0	0	0	0
Res = 0x2	0	1	0	0	0	0	0	0	0	0	0	0	0	0	0	0	0	0	0
Res = 0x1	0	1	0	0	0	0	0	0	0	0	0	0	0	0	0	0	0	0	0
Res = 0x0	0	1	0	0	0	0	0	0	0	0	0	0	0	0	0	0	0	0	0

Note that at 0G, the 19 bit value equals 0x20000. This means for resolution 0 and 1, the 16 bit output is centered around 0 and in 2s complement format. For resolution 2, 0G equals 0x8000 and for resolution 3 0G equals 0x4000.

For 0G + 1LSB_{19bit} this becomes:

	18	17	16	15	14	13	12	11	10	9	8	7	6	5	4	3	2	1	0
Res = 0x3	0	1	0	0	0	0	0	0	0	0	0	0	0	0	0	0	0	0	1
Res = 0x2	0	1	0	0	0	0	0	0	0	0	0	0	0	0	0	0	0	0	1
Res = 0x1	0	1	0	0	0	0	0	0	0	0	0	0	0	0	0	0	0	0	1
Res = 0x0	0	1	0	0	0	0	0	0	0	0	0	0	0	0	0	0	0	0	1

For 0G - 1LSB_{19bit} this becomes:

	18	17	16	15	14	13	12	11	10	9	8	7	6	5	4	3	2	1	0
Res = 0x3	0	0	1	1	1	1	1	1	1	1	1	1	1	1	1	1	1	1	1
Res = 0x2	0	0	1	1	1	1	1	1	1	1	1	1	1	1	1	1	1	1	1
Res = 0x1	0	0	1	1	1	1	1	1	1	1	1	1	1	1	1	1	1	1	1
Res = 0x0	0	0	1	1	1	1	1	1	1	1	1	1	1	1	1	1	1	1	1

Calculation of conversion time

There are four parameters that determine the conversion time for a specific measurement: OSR, DIG_FILT, OSR2 and ZYXT. The typical conversion time can be calculated as follows:

$$T_{CONV} = T_{STANDBY} + T_{ACTIVE} + n \cdot T_{CONVXYZ} + m \cdot T_{CONVT}$$

Where $T_{CONVXYZ}$ is the conversion time for 1 magnetic measurement (1 axis), T_{CONVT} the conversion time for the temperature measurement. Based on ZYXT, the values of n and m can be filled in.

$$T_{STANDBY} + T_{ACTIVE} = 0.5ms$$

$$T_{CONVXYZ} = 0.063ms \cdot 2^{OSR} \cdot (2 + 2^{DIG_FILT})$$

$$T_{CONVT} = 0.18ms \cdot 2^{OSR2}$$

In the 'worst case', when all parameters are max and ZYXT equals 0b1111, the conversion time typically is 198.5ms. Over temperature, these values will deviate due to the clock which gets slower at rising temperature.

Sensitivity

The sensitivity is dependent on the selected gain (Gain_sel) and the chosen resolution (RES_X/Y/Z). The typical sensitivity in $\mu\text{T}/\text{LSb}$ for different combination is as followed:

GAIN_SEL	RES = 0		RES = 1		RES = 2		RES = 3	
	SENS _{XY}	SENS _Z	SENS _{XY}	SENS _Z	SENS _{XY}	SENS _Z	SENS _{XY}	SENS _Z
0	0.805	1.468	1.610	2.936	3.220	5.872	6.440	11.744
1	0.644	1.174	1.288	2.349	2.576	4.698	5.152	9.395
2	0.483	0.881	0.966	1.762	1.932	3.523	3.864	7.046
3	0.403	0.734	0.805	1.468	1.610	2.936	3.220	5.872
4	0.322	0.587	0.644	1.174	1.288	2.349	2.576	4.698
5	0.268	0.489	0.537	0.979	1.073	1.957	2.147	3.915
6	0.215	0.391	0.429	0.783	0.859	1.566	1.717	3.132
7	0.161	0.294	0.322	0.587	0.644	1.174	1.288	2.349

The output range depends on the resolution and the saturation level of the IMC. This is given below for both temperature compensation enabled and disabled. The difference between both is explained in the application note on temperature compensation.

ABA		TCMP_EN = 0x0		TCMP_EN = 0x1	
		RANGE	TYPE	RANGE	TYPE
RES _T	0	$\pm 2^{15}$	2's complement $0\mu\text{T} = 0\text{LSB}$	$\pm 2^{15}$	unsigned $0\mu\text{T} = 2^{15}\text{LSB}$
	1	$\pm 2^{15}$	2's complement $0\mu\text{T} = 0\text{LSB}$	$\pm 2^{15}$	unsigned $0\mu\text{T} = 2^{15}\text{LSB}$
	2	± 22000	unsigned $0\mu\text{T} = 2^{15}\text{LSB}$	N/A	
	3	± 11000	unsigned $0\mu\text{T} = 2^{15}\text{LSB}$		

Available hardware (EVB)

A EVB is available for easy access to the MLX90393. A MLX90393 is soldered to the PCB and extra samples are included in the box. Both SPI and I²C are supported.

Default the PCB is prepared to be used with SPI. Simply connect VDD, VSS, MISO, MOSI, CS and SCLK to the microcontroller to communicate with the MLX90393

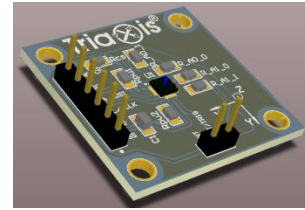

To use I²C, some soldering is needed depending on the address needed:

- Rcs should be shorted (or place 0 Ohm);
- The I2C address should be set to the desired value by shorting the correct R_Ax_x pads. Default 0 Ohm is placed on R_A0_0 and R_A1_0 which sets the I2C address to 0x19 (Both A0 and A1 are shorted to VSS). Moving the resistor to R_Ax_1 will connect the pin to the VDD.
- Optionally Rpu1 and Rpu2 are foreseen as a pull up for the SCL and SDA communication lines. Usually this pull up is on the microcontroller side.

Only 4 wires are needed from the EVB to the microcontroller to work with I²C: VDD, VSS, SDA and SCL.

Also on the PCB is a pad for an optional decoupling capacitor C1 (Between VDD and VSS).

Below the schematic of the EVB can be seen. The orange external components are placed by default.

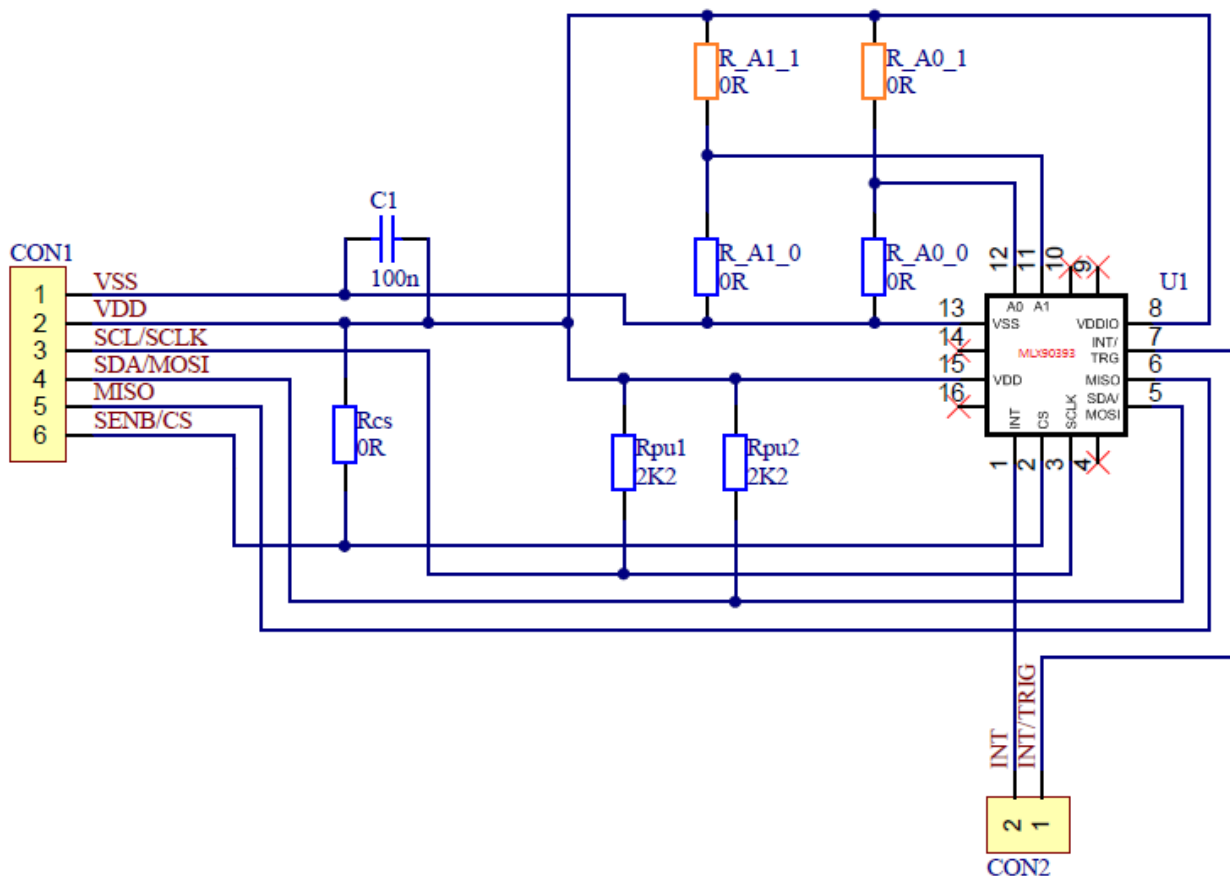

Example #1: Rotary Application

Rotary applications are among the most common and are also the easiest to implement as they require only two axes of data and a minimum amount of post processing of the data.

Magnetic Configuration

A diametrically magnetized magnet (similar to the one shown in the above image) is normally used and recommended. While there is no restriction on size beyond that needed to fulfill the magnetic field strength requirement (10-50mT) it is advised to not make the magnet too small in diameter as errors caused by off-axis assembly errors increase as the magnet diameter shrinks. A general rule of thumb is that the magnet diameter has to be ten times the maximum off-axis error to maintain a nonlinearity error of less than 1 degree. The following magnet configurations have been used with the sensor and yielded good results. Care should be taken to select a magnet that does not exceed the magnetic field limits over temperature, lifetime aging, and mechanical tolerances and wear.

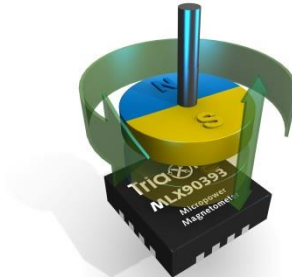

Magnet	Diameter (mm)	Height (mm)	Magnetization	Material	Air Gap (mm)		Available Part Number
					Min	Max	
1	10.52	2.72	Diametrical	SmCo	4.0	7.0	Dexter 6312007
2	6.50	2.69	Diametrical	SmCo	3.0	5.0	Dexter 6312002
	TBD	TBD	Diametrical	NdFeB	TBD	TBD	
	TBD	TBD	Diametrical	NdFeB	TBD	TBD	
	TBD	TBD	Diametrical	Ceramic	TBD	TBD	

Note: For applications with high performance requirements it is suggested that a magnet supplier be contacted to define the best magnet for the application.

Suggested EEPROM Configuration

For rotary applications three EEPROM addresses may need to be modified. They control the gain, filter, and communication mode among others. Suggested EEPROM values when using magnet 1 in the above table are given below. These settings allow a sampling rate of 100Hz with minimal noise and a nominal airgap of 6mm.

Parameter	Value
ANA_RESERVED_LOW	0x0
BIST	0x0
Z_SERIES	0x0
GAIN_SEL	0x5
HALL_CONF	0xC
TRIG_INT	0x0
COMM_MODE	0x0
WOC_DIFF	0x0

Parameter	Value
EXT_TRIG	0x0
TCMP_EN	0x0
BURST_SEL	0x0
BURST_DATA_RATE	0x0
OSR2	0x0
RES_XYZ	0x1
DIG_FILT	0x5
OSR	0x0

Modifications to the above table can be made based on the users performance objectives.

Rotary Code Example

The following flowchart is an example for the microcontroller to configure the MLX90393 via a series of register read/write operations, permanently store the modifications, and continuously read out the magnetic information. Processing of the data is performed to obtain a magnetic angle and compute whether the gain should be modified.

After processing, the data is collected, formatted, and can be sent to a PC via the virtual serial port.

A SM/RM cycle is performed approximately every 100ms which does not include the time required to transmit the various data over the serial port.

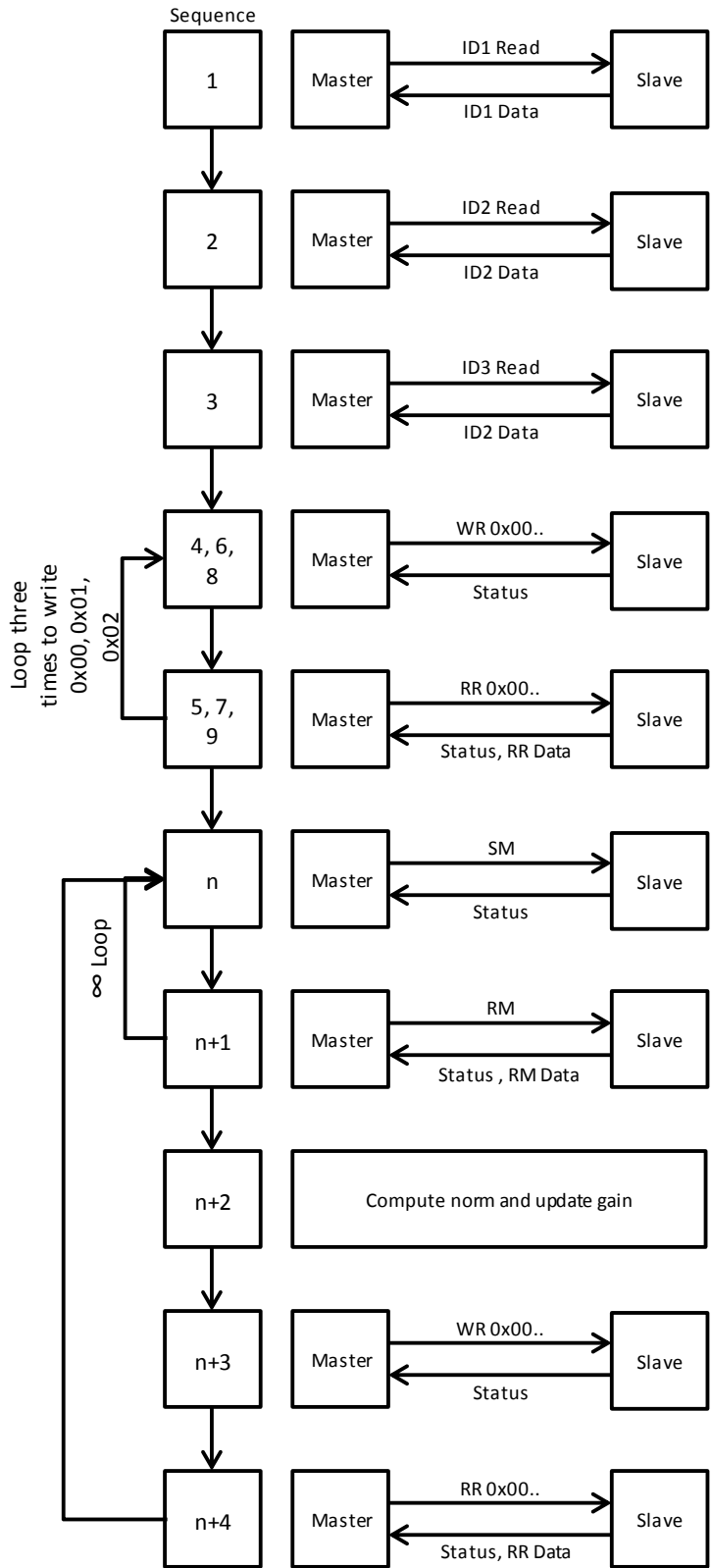

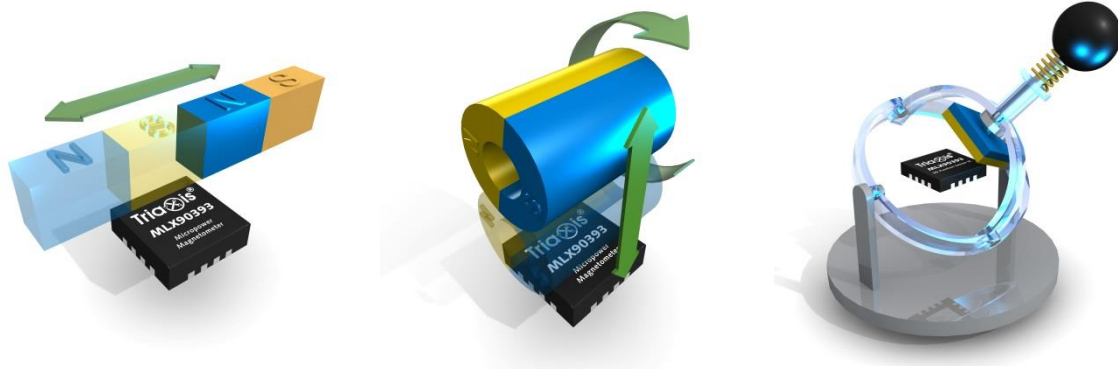

For the latest version of this document, go to our website at
www.melexis.com

Or for additional information contact your regional sales office

Europe, Africa, Asia:
Phone: +32 1367 0495
Email: sales_europe@melexis.com

America:
Phone: +1 248 306 5400
Email: sales_usa@melexis.com

ISO/TS 16949 and ISO 14001 Certified