

# CHAPTER 3 WIRING

## 3.1 Basic Wiring Diagram

Users must connect wiring according to the following circuit diagram shown below.

For VFDXXXSXXA/B/D

3

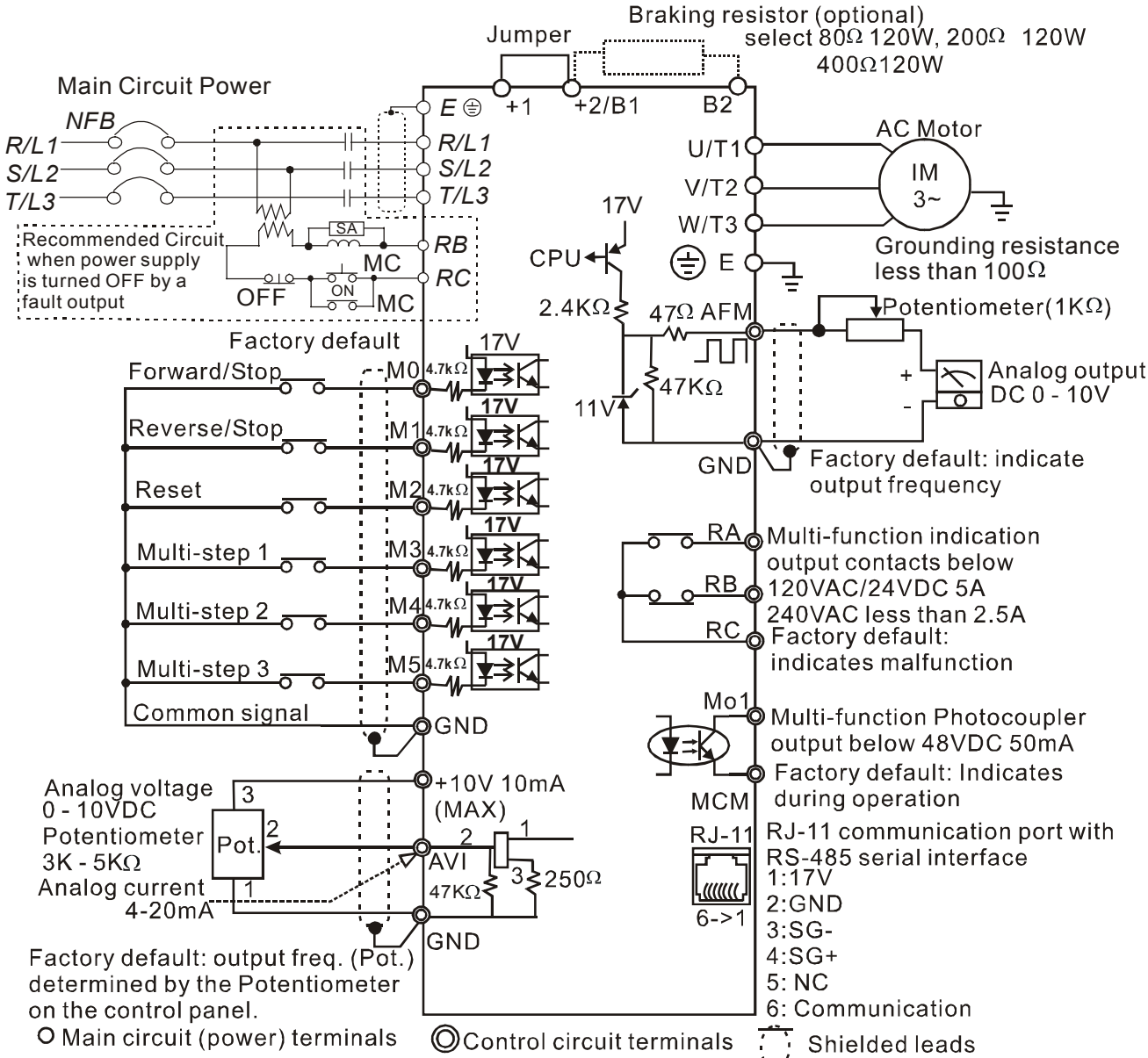

NOTE: Do not plug in a Modem or telephone line to the RS-485 communication port, permanent damage may result. Terminal 1 & 2 are the power sources for the optional copy keypad and should not be used while using RS-485 communication.

\* If it is single phase model, please select any of the two input power terminals in main circuit power.

## For VFDXXXSXXE

### NPN (sink mode)

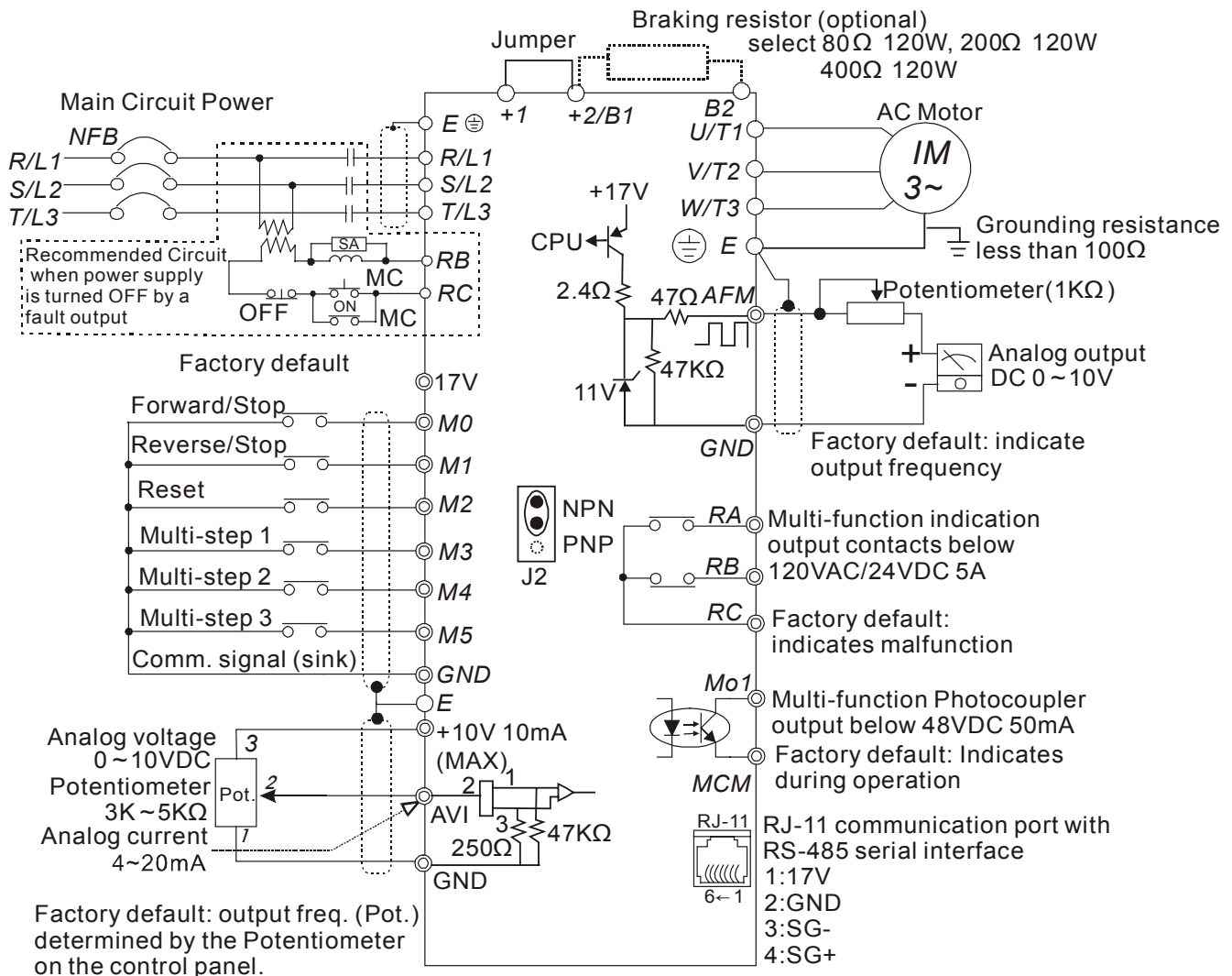

○ Main circuit (power) terminals    ◎ Control circuit terminals    ◌ Shielded leads

NOTE: Do not plug in a Modem or telephone line to the RS-485 communication port, permanent damage may result. Terminal 1 & 2 are the power sources for the optional copy keypad and should not be used while using RS-485 communication.

\* If it is single phase model, please select any of the two input power terminals in main circuit power.

**For VFDXXXSXXE**  
**PNP (source mode)**

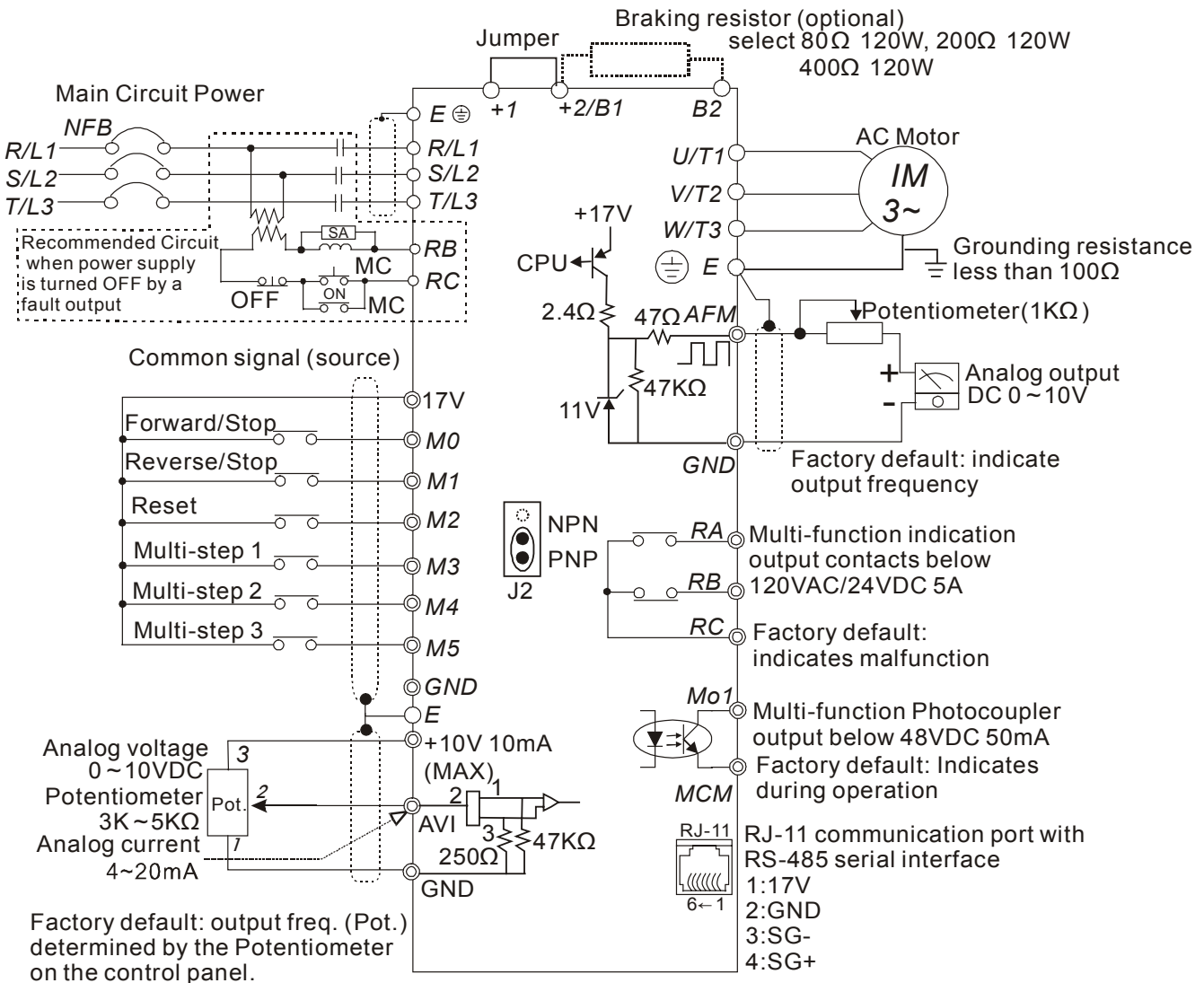

3

○ Main circuit (power) terminals    ⊙ Control circuit terminals    ⊞ Shielded leads

NOTE: Do not plug in a Modem or telephone line to the RS-485 communication port, permanent damage may result. Terminal 1 & 2 are the power sources for the optional copy keypad and should not be used while using RS-485 communication.

\* If it is single phase model, please select any of the two input power terminals in main circuit power.

### 3.2 External Wiring

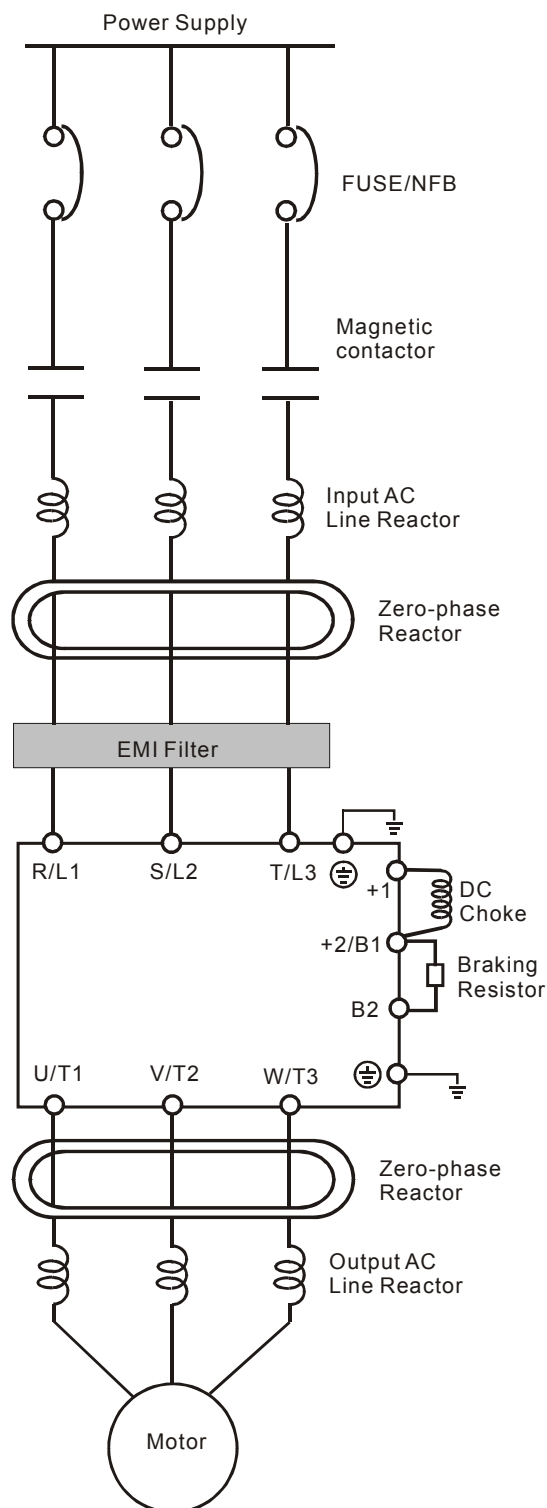

Items	Explanations
Power supply	Please follow the specific power supply requirement shown in APPENDIX-A.
Fuse/NFB (Optional)	There may be inrush current during power up. Please check the chart of APPENDIX B and select the correct fuse with rated current. NFB is optional.
Magnetic contactor (Optional)	Please do not use a Magnetic contactor as the I/O switch of the AC drive, this will reduce the operating life cycle of the AC drive.
Input AC Line Reactor (Optional)	In order to improve the input power factor, reduces harmonics and protection from AC line disturbances. (Surge, switching spike, power flick, etc.) AC line reactor should be installed when the power supply capacity is 500kVA or more and exceeds 6 times of the inverter capacity, or the wiring distance within 10m.
Zero-phase Reactor (Ferrite Core Common Choke) (Optional)	Zero phase reactors are used to reduce radio noise specify when the audio equipments installed near the inverter. Good effective for noise reduction on both the input and output sides. Attenuation quality is good in a wide range from AM band to 10Mhz. Appendix B for specifies zero phase reactors. (RF220X00A)
EMI filter (Optional)	To reduce the electromagnetic interference. Please refer to Appendix B for detail.
Braking Resistor (Optional)	Used to reduce stopping time of the motor. Please refer to the chart on Appendix B for specific Braking Resistors.
Output AC Line Reactor (Optional)	Motor surge voltage amplitudes depending on the motor cable length. For long motor cable application, it is necessary installed on the inverter output side.

### 3.3 Main Circuit Wiring

#### 1. Main Circuit Terminals

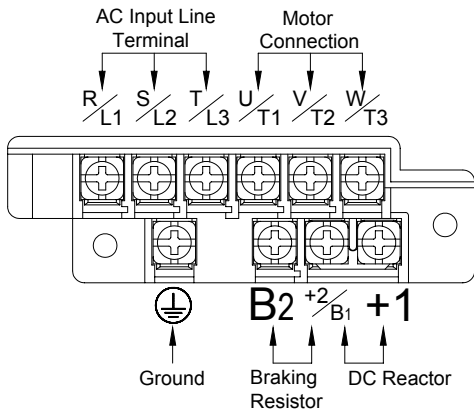

002S23B, 004S23B, 004S43B,  
007S23B, 007S43B, 015S21A/B,  
015S23A/B, 015S43B, 022S23A/B,  
022S43B

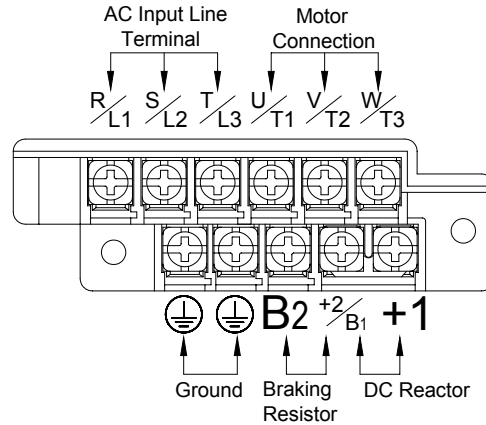

002S23A, 004S23A/E, 007S23A/E,  
015S23D, 015S43A/D/E, 022S23D,  
022S43A/D/E

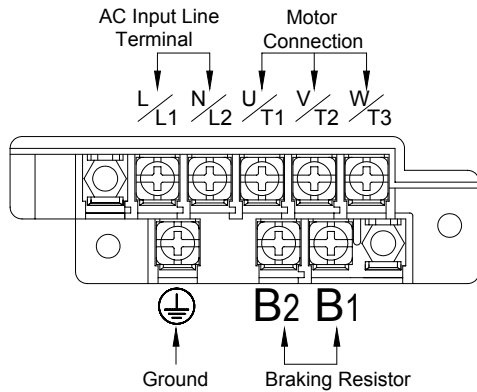

002S11A/B, 004S11A/B,  
007S11A/B

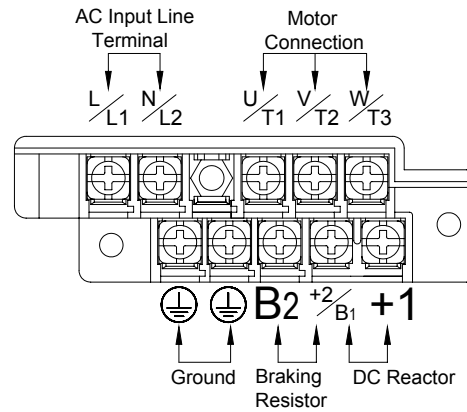

002S21A/E, 004S21A/E, 007S21A/E,  
015S21D/E, 022S21D/E

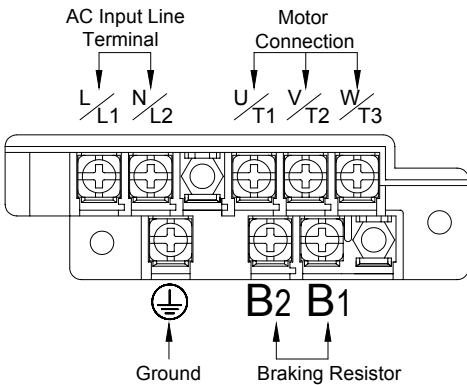

022S21A/B

**0.25-1 HP (1HP: 230V/460V) and VFD015S23D**  
Wire Gauge: 14-20 AWG  
Wire Type: copper wire only, 75°C  
Torque: 12 kgf-cm (10 in-lbf)

**1-3 HP (1HP: 115V)**  
Wire Gauge: 10-18 AWG  
Wire Type: stranded copper wire only, 75°C  
Torque: 20 kgf-cm (17.4 in-lbf)

3

## 2. Terminal Explanations

Terminal Symbol	Explanation of Terminal Function
R/L1, S/L2, T/L3	AC line input terminals (three phase)
L/L1, N/L2	AC line input terminals (single phase)
U/T1, V/T2, W/T3	Motor connections
+2/B2 – B1	Connections for Braking Resistor (optional)
+2/+1 – B1	Connections for DC Link Reactor (optional)
⊕	Earth Ground

## 3. Terminal Dimensions

Model VFD-	002S11A/B, 002S21A/B/E, 002S23A/B, 004S11A/B, 004S 21A/B/E, 004S23A/B, 004S43A/B/E, 007S21A/B/E, 007S23A/B, 007S43A/B/E, 015S23D	007S11A/B, 015S21A/B/D/E, 015S23A/B, 015S43A/B/D/E, 022S21A/B/D/E, 022S23A/B/D, 022S43A/B/D/E
Terminal Specification (Terminal $\phi$ )	M3.5	M4

## 3.4 Control Terminal Wiring (Factory Setting)

### A. XXXSXXA/B/D

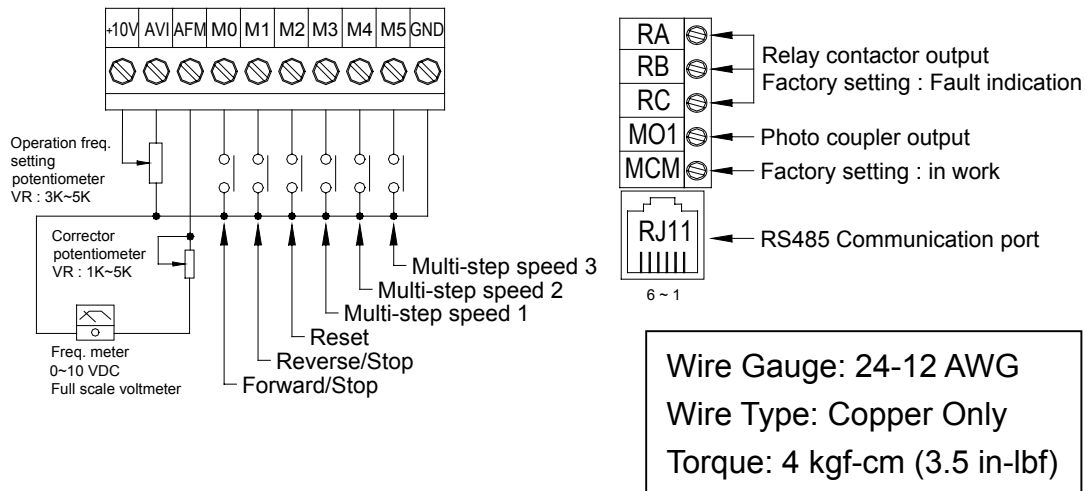

## B. XXXSXXE

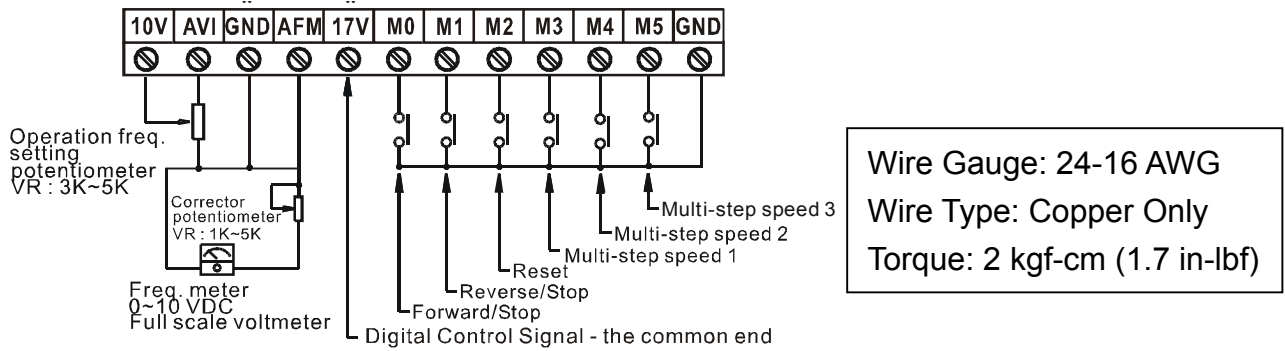

### 1. Terminal Explanations:

Terminal symbols	Terminal name	Remarks
RA-RC	Multi-Function Indication Output Contact	Refer to Pr.3-06 Relay output contact RA-RC (N.O. Contact) RB-RC (N.C. Contact)
RB-RC	Multi-Function Indication Output Contact	
MO1-MCM	Multi-function PHC output	Refer to Pr.3-05
RJ-11	Serial communication port	RS-485 serial communication interface
+10V-GND	Power for speed setting	Power Supply (+10V/10mA)
AVI-GND	Analog voltage/current freq. command	0 to +10 V (Max. Output Frequency) Input <b>or</b> 4 to 20mA (Max. Output Frequency) Input
AFM-GND	Analog frequency/current meter	0 to +10 V (Max. output Frequency) Output
17V	DC Voltage Source	(17V/20mA), used for source mode.
M0	Multi-function auxiliary input	Refer to Pr.4-04 to Pr.4-08
M1	Multi-function input 1	
M2	Multi-function input 2	
M3	Multi-function input 3	
M4	Multi-function input 4	
M5	Multi-function input 5	
GND	Digital Signal Common	

**Note:** Use twisted-shielded, twisted-pair or shielded-lead wires for the control signal wiring. It is recommended to run all signal wiring in a separate steel conduit. The shield wire should only be connected at the drive. Do not connect shield wire on both ends.

### 3.5 Wiring Notes

- CAUTION:** Do not connect the AC input to any of the U/T1, V/T2, W/T3 terminals, as it will damage the AC drive.
- WARNING:** Ensure all screws are tightened to the proper torque rating.

3. During installation, follow all local electrical, construction, and safety codes for the country the drive is to be installed in.
4. Ensure that the appropriate protective devices (circuit breaker or fuses) are connected between the power supply and AC drive.
5. Make sure that the leads are connected correctly and the AC drive is properly grounded. (Ground resistance should not exceed  $100\Omega$ . For 460V-class AC drive, the ground resistance should not exceed  $10\Omega$ .)
6. Use ground leads that comply with AWG/MCM standards and keep them as short as possible.
7. Multiple VFD-S units can be installed in one location. All the units should be grounded directly to a common ground terminal. The VFD-S ground terminals may also be connected in parallel, as shown in the figure below. **Ensure there are no ground loops.**

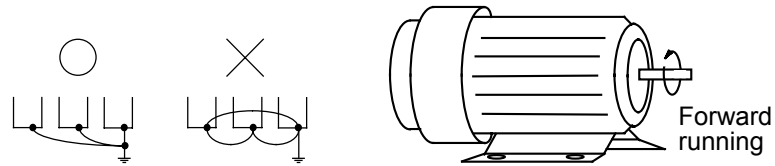

8. When the AC drive output terminals U/T1, V/T2, and W/T3 are connected to the motor terminals U/T1, V/T2, and W/T3, respectively, the motor will rotate counterclockwise (as viewed from the shaft ends of the motor) when a forward operation command is received. To reverse the direction of motor rotation, switch over any of the two motor leads.
  9. Make sure that the power source is capable of supplying the correct voltage and required current to the AC drive.
  10. Do not attach or remove wiring when power is applied to the AC drive.
  11. Do not monitor the signals on the circuit board while the AC drive is in operation.
  12. For the single-phase applications, the AC input line can be connected to any two of the three input terminals R/L1, S/L2, T/L3.
- Note: This drive is not intended for the use with single-phase motors.**
13. Route the power and control wires separately, or at  $90^\circ$  angle to each other.



14. If a filter is required for reducing EMI (Electro Magnetic Interference), install it as close as possible to AC drive. EMI can also be reduced by lowering the Carrier Frequency.
15. If the AC drive is installed in the place where a load reactor is needed, install the filter close to U/T1, V/T2, W/T3 side of AC drive. Do not use a Capacitor or L-C Filter (Inductance-Capacitance) or R-C Filter (Resistance-Capacitance).
16. When using a GFCI (Ground Fault Circuit Interrupt), select current sensor with not less than 200mA, and not less than 0.1-second detection to avoid nuisance tripping

### 3.6 Motor Operation Precautions

1. When using the AC drive to operate a standard 3-phase induction motor, notice that the energy loss is greater than an inverter duty motor.
2. While using the standard induction motor at low speed, the temperature of the motor may rise, so do not operate the motor at low speed for a long period of time.
3. When the standard motor operates at low speed, the motor output torque will decrease, please decrease the load during the operation.
4. If 100% output torque is desired at low speed operation, it may be necessary to use a special motor that can handle this load (inverter duty).