

CHAPTER 9

Vertical Antennas

THANKS DJ2YA

Uli Weiss, DJ2YA, is an all-around radio amateur. His more-than-casual interest and in-depth knowledge of antenna matters and his eminent knowledge of the English language (Uli teaches English at a German “Gymnasium”) has made him one of the few persons who could successfully translate the *Low Band*

DXing book into the German language without any assistance from the author. It also makes him a very successful antenna builder and contest operator. Uli was, with Walter Skudlarek, DJ6QT, cofounder of the world-renowned RRDXA Contest Club, which has lead the CQ-WW Club championships for many years.

Uli has been an editor, helping hand and supporter for this chapter on vertical antennas. Thank you for your help, Uli.



The effects of the earth itself and the artificial ground system (if used) on the radiation pattern and the efficiency of vertically polarized antennas is often not understood. They have until recently not been covered extensively in the amateur literature.

The effects of the ground and the ground system are twofold. Near the antenna (in the *near field*), you need a good ground system to collect the antenna return currents without losses. This will determine the *radiation efficiency* of the antenna.

At distances farther away (in the *far field*, also called the *Fresnel zone*), the wave is reflected from the earth and combines with the direct wave to generate the overall radiation pattern. The absorption of the reflected wave is a function of the ground quality and the incident angle. This mechanism determines the *reflection efficiency* of the antenna.

Vertical monopole antennas are often called *ground-*

mounted verticals, or simply verticals. They are, by definition, mounted perpendicular to the earth, and they produce a vertically polarized signal. Verticals are popular antennas for the low bands, since they can produce good low-angle radiation without the very high supports needed for horizontally polarized antennas to produce the same amount of radiation at low takeoff angles.

1. THE QUARTER-WAVE VERTICAL

1.1. Radiation Patterns

1.1.1. Vertical pattern of vertical monopoles over ideal ground

The radiation pattern produced by a ground-mounted quarter-wave vertical antenna is basically one-half that of a half-wave dipole antenna in free space. The dipole is twice the physical size of the vertical and has a symmetrical current distribution. A vertical antenna is frequently referred to as a “monopole” to distinguish it from a dipole. The radiation pattern of a quarter-wave vertical monopole over perfect ground is half of the figure-8 shown for the half-wave dipole in free space. See **Fig 9-1**.

The relative field strength of a vertical antenna with sinusoidal current distribution and a current node at the top is given by:

$$E_f = k \times I \left[\frac{\cos(L \sin \alpha) - \cos L}{\cos \alpha} \right] \quad (\text{Eq 9-1})$$

where

k = constant related to impedance

E_f = relative field strength

α = elevation angle above the horizon

L = electrical length (height) of the antenna

I = antenna current

This equation does not take imperfect ground conditions into account, and is valid for antenna heights between 0° and 180° (0 to $\lambda/2$). The “form factor” inside the square brackets containing the trigonometric functions is often published by itself for use in calculating the field strength of a vertical antenna. If used in this way, however, it appears that short verticals are vastly inferior to tall ones, since the antenna length appears only in the numerator of the fraction.

Replacing the current I in the equation with the term

$$\sqrt{\frac{P}{R_{\text{rad}} + R_{\text{loss}}}}$$

gives a better picture of the actual situation. For short verticals, the value of the radiation resistance is small, and this term largely compensates for the decrease in the form factor. This means that for a constant power input, the current into a small vertical will be greater than for a larger monopole.

The radiation resistance R_{rad} does not determine the current—the sum of the radiation resistance and the loss resistance(s) does. With a less-than-perfect ground system and short, less-than-perfect loading elements (lossy coils used with short verticals), the radiation can be significantly less than the case of a larger vertical (where R_{rad} is large in comparison to the ground loss and where there are no lossy loading devices).

Interestingly, short verticals are almost as efficient radiators as are longer verticals, provided the ground system is good and there are no lossy loading devices. When the losses of the ground system and the loading devices are brought into the picture, however, the sum $R_{\text{rad}} + R_{\text{loss}}$ will get larger, and as a result part of the supplied power will be lost in the form of heat in these elements. For instance, if $R_{\text{rad}} = R_{\text{loss}}$, half of the power will be lost. Note that with very short verticals, these losses can be much higher.

1.1.2. Vertical radiation pattern of a monopole over real ground

The three-dimensional radiation pattern from an antenna is made up of the combination of the direct wave and the wave resulting from reflection from the earth. The following explanation is valid only for reflection of vertically polarized waves. See Chapter 8 on dipole antennas for an explanation of the reflection mechanism for horizontally polarized waves.

For perfect earth there is no phase shift of the vertically polarized wave at the reflection point. The two waves add with a certain phase difference, due only to the different path lengths. This is the mechanism that creates the radiation pattern. Consider a distant point at a very low angle to the horizon. Since the path lengths are almost the same, reinforcement of the direct and reflected waves will be maximum. In case of a perfect ground, the radiation will be maximum just above a 0° elevation angle.

1.1.2.1. The reflection coefficient

Over real earth, reflection causes both amplitude and phase changes. The reflection coefficient describes how the incident (vertically polarized) wave is being reflected. The reflection coefficient of real earth is a complex number with magnitude and phase, and it varies with frequency. In the polar-coordinate system the reflection coefficient consists of:

- The magnitude of the reflection coefficient: It determines how much power is being reflected, and what percentage is being absorbed in the lossy ground. A figure of 0.6 means that 60% will be reflected and 40% absorbed.
- The phase angle: This is the phase shift that the reflected wave will undergo as compared to the incident wave.

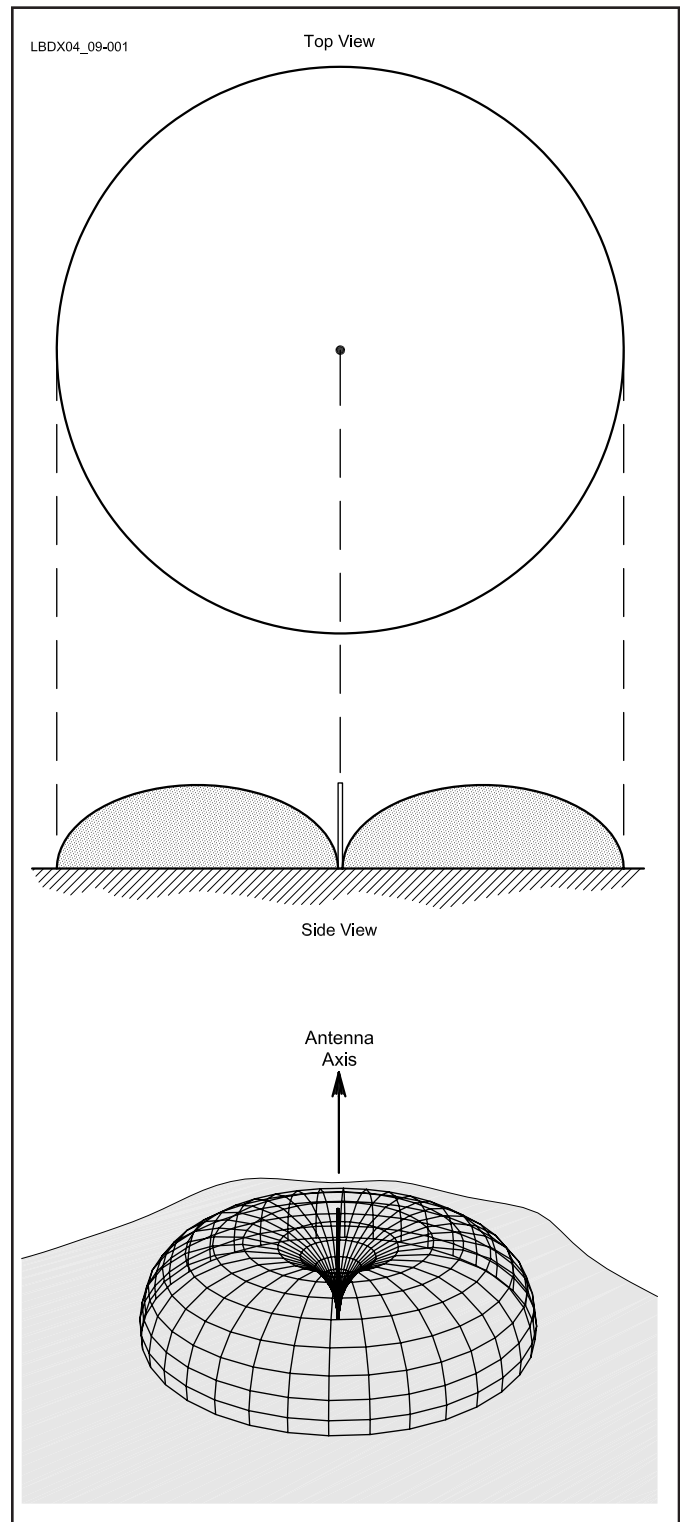

Fig 9-1—The radiation patterns produced by a vertical monopole over perfect ground. The top view is the horizontal pattern, and the side view is the vertical (elevation plane) pattern.

Over real earth the phase is always lagging (minus sign). At a 0° elevation angle, the phase is always -180° . This causes the total radiation to be zero (the incident and reflected waves, which are 180° out-of-phase and equal in magnitude, cancel each other). At higher elevation angles,

the reflection phase angle will be close to zero (typically -5° to -15° , depending on the ground quality).

1.1.2.2. The pseudo-Brewster angle

The magnitude of the vertical reflection coefficient is minimum at a 90° phase angle. This is the reflection-coefficient phase angle at which the so-called *pseudo-Brewster wave angle* occurs. It is called the pseudo-Brewster angle because the RF effect is similar to the optical effect from which the term gets its name. At the pseudo-Brewster angle the reflected wave changes sign. Below the pseudo-Brewster angle the reflected wave will subtract from the direct wave. Above the pseudo-Brewster angle it adds to the direct wave. At the pseudo-Brewster angle the radiation is 6 dB down from the perfect ground pattern (see Fig 9-2).

All this should make it clear that knowing the pseudo-

Brewster angle is important for each band at a given QTH. Most of us use a vertical to achieve good low-angle radiation.

Fig 9-3 shows the reflection coefficient (magnitude and phase) for 3.6 MHz and 1.8 MHz for three types of ground. Over seawater the reflection-coefficient phase angle changes from -180° at a 0° wave angle to -0.1° at less than 0.5° wave angle! The pseudo-Brewster angle is at approximately 0.2° over saltwater.

1.1.2.3. Ground-quality characterization

Ground quality is defined by two parameters: the dielectric constant and the conductivity, expressed in milliSiemens per meter (mS/m). Table 5-2 in Chapter 5 shows the characterization of various real-ground types. The table also shows five distinct types of ground, labeled as very good, average, poor, very poor and extremely poor. These come from Terman's classic *Radio Engineers' Handbook*, and are also used by Lewallen in his *ELNEC* and *EZNEC* modeling programs. The denominations and values listed in Table 5-2 are the standard ground types used throughout this book for modeling radiation patterns. In the real world, ground characteristics are never homogeneous, and extremely wide variations over short distances are common. Therefore any modeling results based on homogeneous ground characteristics will only be as accurate as the homogeneity of the ground itself.

1.1.2.4. Brewster angle equation

Terman (*Radio Engineers' Handbook*) publishes an equation that gives the pseudo-Brewster angle as a function of the ground permeability, the conductivity and the frequency. The chart in Fig 9-4 uses the Terman equation. Note especially how saltwater has a dramatic influence on the low-angle radiation performance of verticals. In contrast, a sandy, dry ground yields a pseudo-Brewster angle of 13° to 15° on the low bands, and a city (heavy industrial) ground yields a pseudo-Brewster angle of nearly 30° on all frequencies! This means that under such circumstances the radiation efficiency

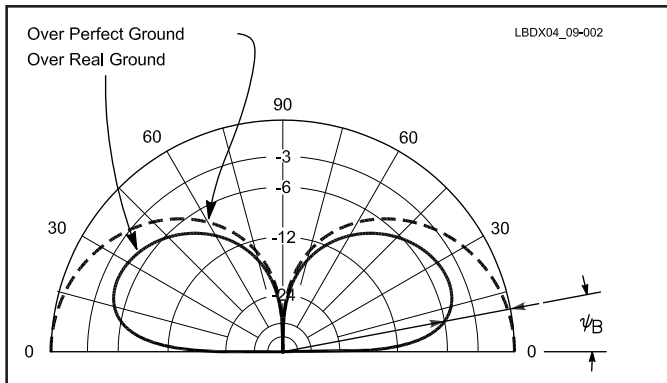

Fig 9-2—Vertical radiation patterns of a $\lambda/4$ monopole over perfect and imperfect earth. The pseudo-Brewster angle is the radiation angle at which the real-ground pattern is 6 dB down from the perfect-ground pattern.

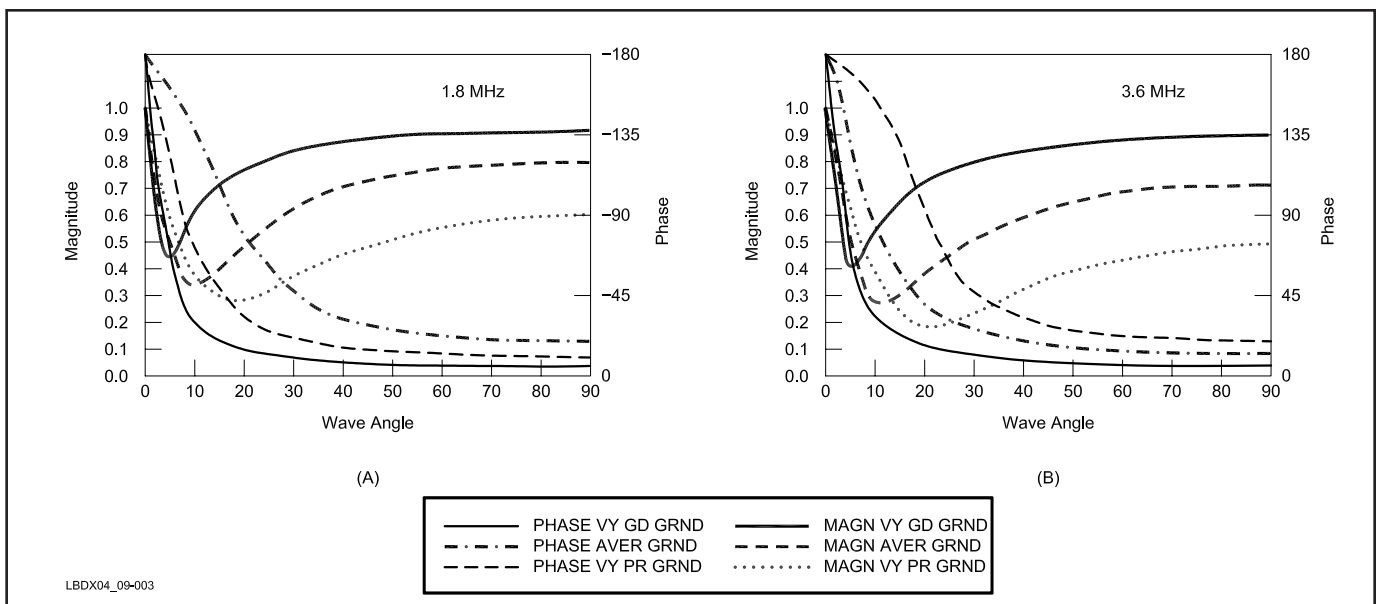

Fig 9-3—Reflection coefficient (magnitude and phase) for vertically polarized waves over three different types of ground (very good, average, and very poor).

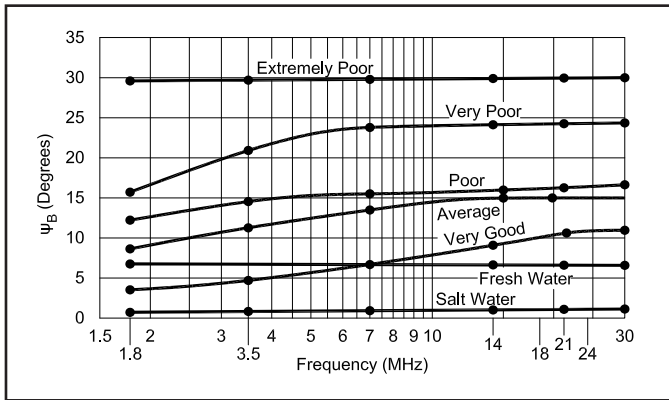

Fig 9-4—Pseudo-Brewster angle for different qualities of reflecting ground. Note that over salt water the pseudo-Brewster angle is constant for all frequencies, at less than 0.1°! That's why vertical antennas located right at the saltwater shore get out so well.

for angles under 30° will be severely degraded in a city environment.

1.1.2.5. Brewster angle and radials

Is there anything you can do about the pseudo-Brewster angle? Very little. Ground-radial systems are commonly used to reduce the losses in the near field of a vertical antenna. These ground-radial systems are usually 0.1 to 0.5 λ long, too short to improve the earth conditions in the area where reflection near the pseudo-Brewster angle takes place.

For quarter-wave verticals the Fresnel zone (the zone

where the reflection takes place) is 1 to 2 λ away from the antenna. For longer verticals (such as a half-wave vertical) the Fresnel zone extends up to 100 wavelengths away from the antenna (for an elevation angle of about 0.25°).

This means that a good radial system improves the efficiency of the vertical in collecting return currents and shielding from lossy ground, but will not influence the radiation by improving the reflection mechanism in the Fresnel zone. Of course you could add 5 λ long radials, and keep the far ends of these radials less than 0.05 λ apart by using enough radials. But that seems rather impractical for most of us! In most practical cases radiation at low takeoff angles will be determined only by the real ground around the vertical antenna.

Conclusion

This information should make it clear that a vertical may not be the best antenna if you are living in an area with very poor ground characteristics. This has been widely confirmed in real life—Many top-notch DXers living in the Sonoran desert or in mountainous rocky areas on the West Coast swear by horizontal antennas for the low bands, at least on 80 meters, while some of their colleagues living in flat areas with rich fertile soil, or even better, on such a ground near the sea coast, will be living advocates for vertical antennas and arrays made of vertical antennas.

On Topband another mechanism enters into the game—the effect of power coupling (see Chapter 1, Section 3.5), which makes a vertically polarized antenna the better antenna in most places away from the equator (eg, North America and Europe) due to the influence of the Earth's magnetic field. In addition,

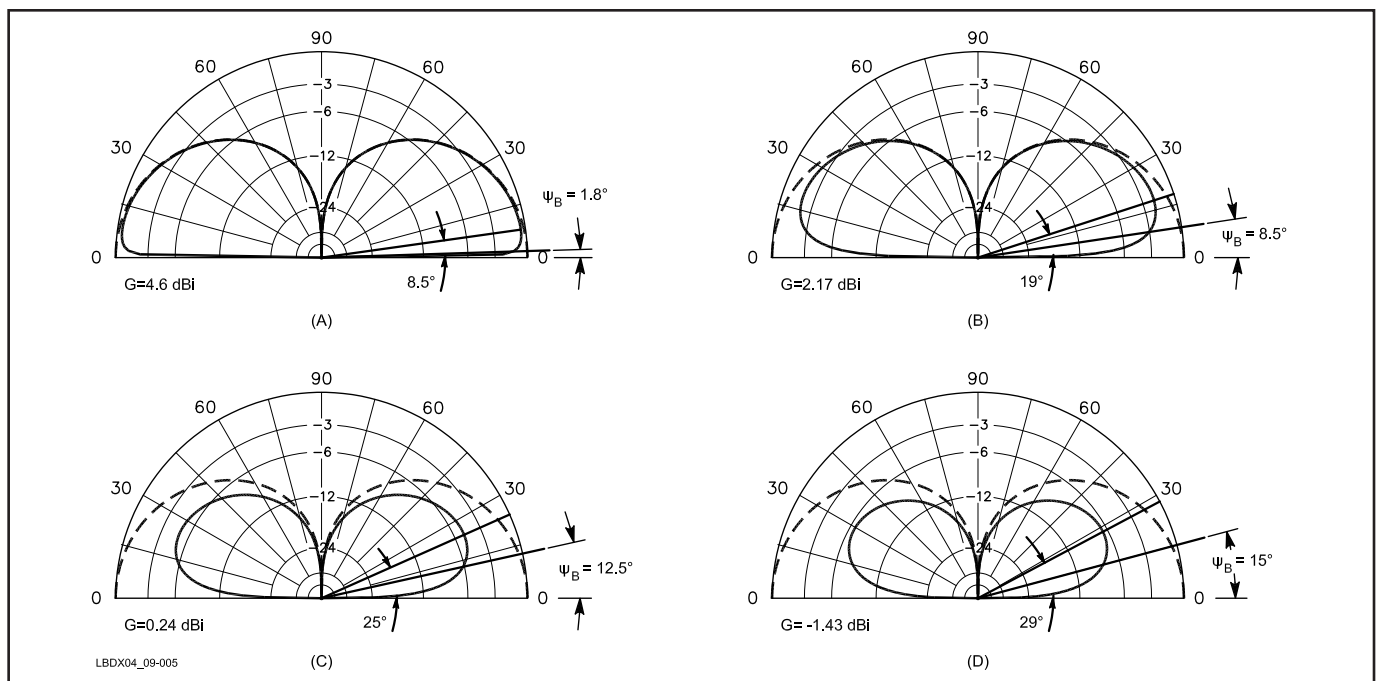

Fig 9-5—Vertical-plane radiation patterns of 80-meter $\lambda/4$ verticals over four standard types of ground. At A, over saltwater. At B, over very good ground. At C, over average ground. At D, over very poor ground. In each case using 64 radials, each 20 meters long. The perfect ground pattern is shown in each pattern as a reference (broken line, with a gain of 5.0 dBi). This reference pattern also allows us to calculate the pseudo-Brewster angle. The patterns and figures were obtained using the NEC-4 modeling program. (Modeling was done by R. Dean Straw, N6BV.)

horizontally polarized antennas producing a low radiation angle on 160 meters are out of reach for all but a few, who have antenna supports that are several hundred meters high!

1.1.2.6. Vertical radiation patterns

It is important to understand that gain and directivity are two different things. A vertical antenna over poor ground may show a good wave angle for DX, but its gain may be poor. The difference in gain at a 10° elevation angle for a quarter-wave vertical over very poor ground, as compared to the same vertical over sea-water, is an impressive 6 dB. **Fig 9-5** shows the vertical-plane radiation pattern of a quarter-wave vertical over four types of “real” ground:

- Seawater
- Excellent ground
- Average ground
- Extremely poor ground

The patterns in Fig 9-5 are all plotted on the same scale.

1.1.2.7. Vertical radiation patterns over sloping grounds

So far all our discussions about radiation patterns assumed we have perfectly homogeneous flat ground stretching for tens of wavelengths around the antenna. In Section 1.1.2 of Chapter 5, I discussed the influence of sloping terrain on vertical radiation patterns of antennas on the low bands. **Fig 9-6** shows that a terrain that slopes downhill in the direction of the target is as helpful for vertical antennas as it is for horizontally polarized antennas. On the other hand, an upwards-sloping terrain works the other way!

1.1.3. Horizontal pattern of a vertical monopole

The horizontal radiation pattern of both the ground-mounted monopole and the vertical dipole is a circle.

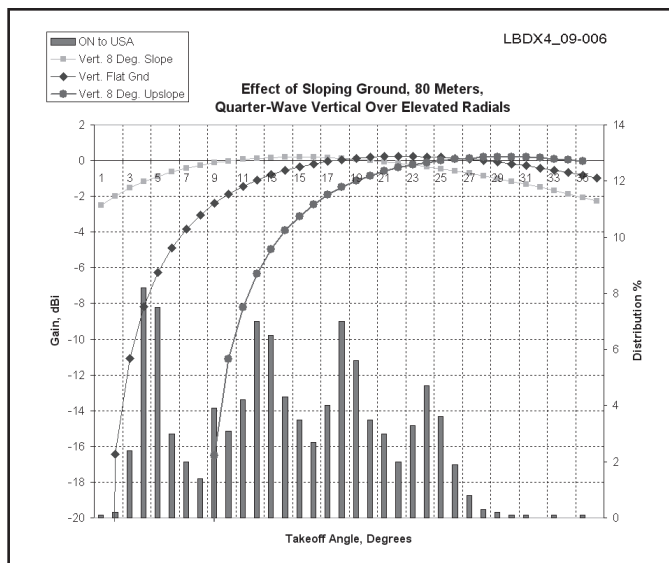

Fig 9-6—The bar graph represents the distribution of the wave angles encountered on 80 meters on a Europe to USA path. Modeling was done over good ground. The wave angles are shown for a $\lambda/4$ vertical over flat ground, over an uphill slope of 8° and over a downhill slope of 8°. The downhill slope is very helpful when it comes to very low angles.

1.2. Radiation Resistance of Monopoles

The IRE definition of radiation resistance says that radiation resistance is the total power radiated as electromagnetic radiation, divided by the *net* current causing that radiation.

The radiation resistance value of any antenna depends on where it is fed (see definition in Chapter 6, Section 3). I’ll call the radiation resistance of a vertical antenna at a point of current maximum as $R_{rad(I)}$ and the radiation resistance of a vertical antenna when fed at its base as $R_{rad(B)}$. For verticals greater than one quarter-wave in height, these two are not the same. Why is it important to know the radiation resistance of our vertical? The information is required to calculate the efficiency of the vertical:

$$Eff = \frac{R_{rad}}{R_{rad} + R_{loss}}$$

The radiation resistance of the antenna plus the loss resistance R_{loss} is the resistive part of the feed-point impedance of the vertical. The feed-point resistance (and reactance) is required to design an appropriate matching network between the antenna and the feed line.

Fig 9-7 shows $R_{rad(I)}$ of verticals ranging in electrical height from 20° to 540°. (This is the radiation resistance referred to the current maximum.) The radiation resistance of a vertical shorter than or equal to a quarter wavelength and fed at its base [thus $R_{rad(I)} = R_{rad(B)}$] can be calculated as follows:

$$R_{rad} = \frac{1450 h^2}{\lambda^2} \quad (Eq 9-2)$$

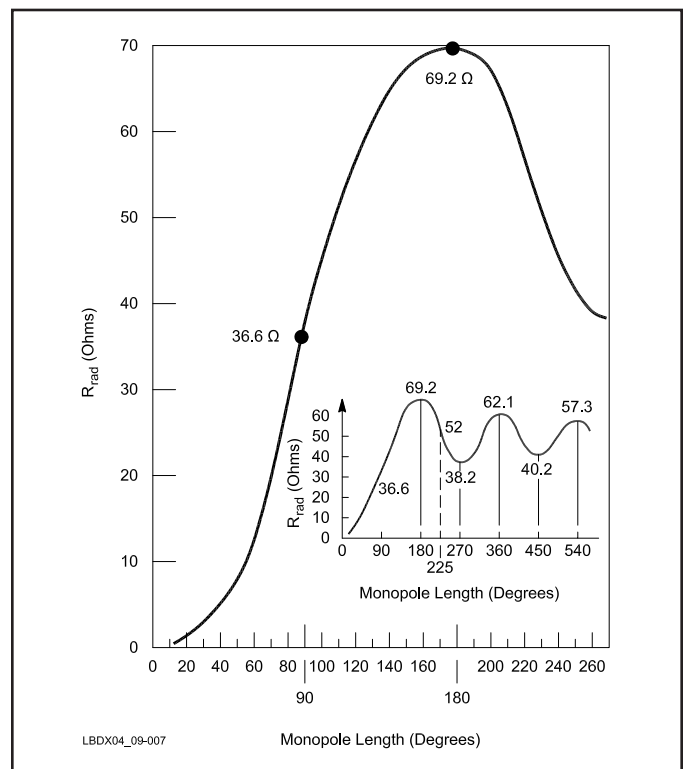
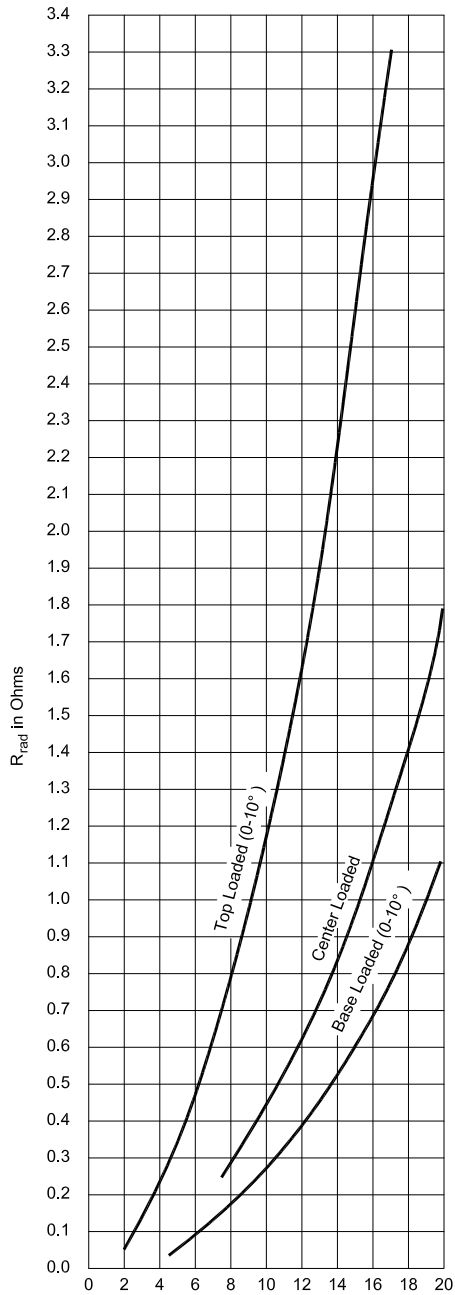
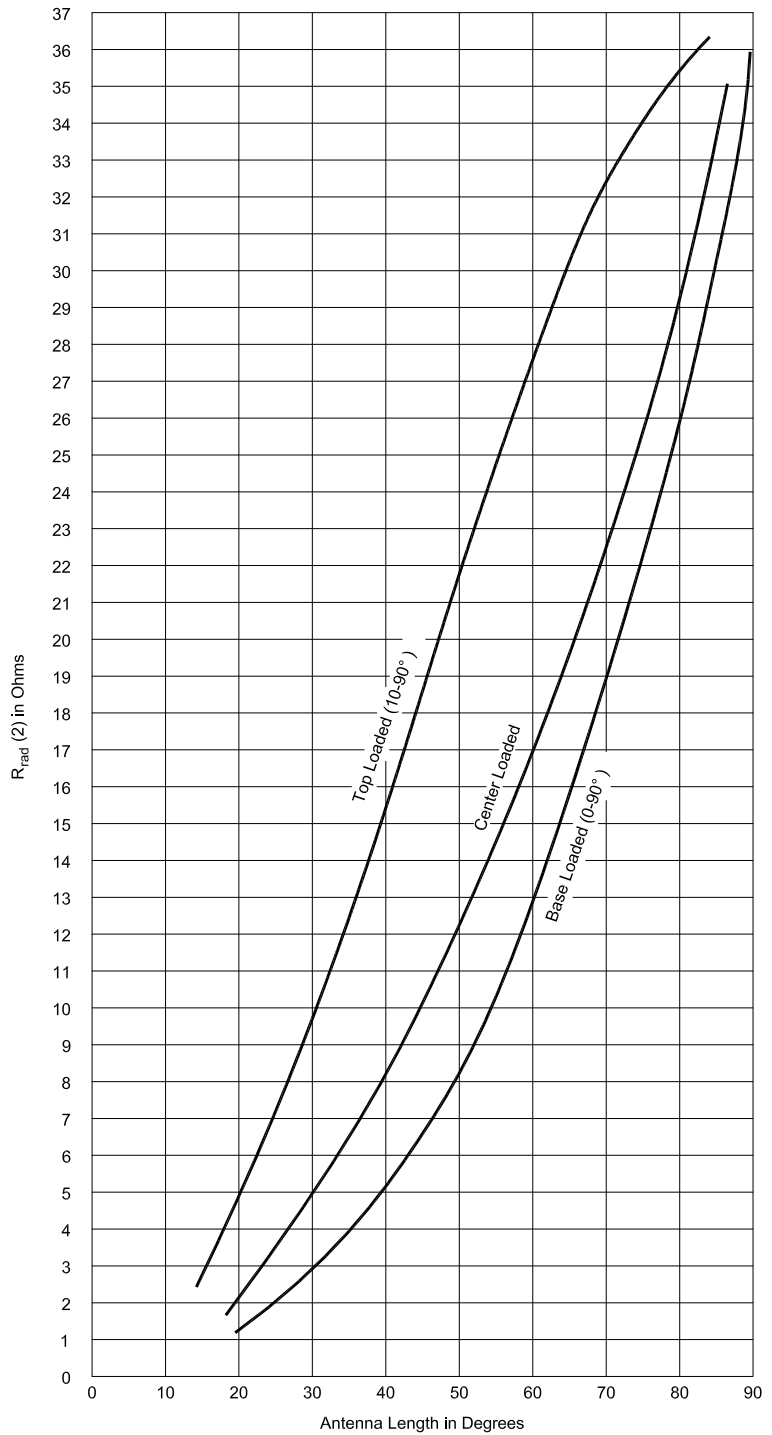

Fig 9-7—Radiation resistances ($R_{rad(I)}$, at the current maximum) of monopoles with sinusoidal current distribution. The chart can also be used for dipoles, but all values must be doubled.



(A)



(B)

Fig 9-8—Radiation resistance charts (R_{rad}) for verticals up to 90° or $\lambda/4$ long. At A, for lengths up to 20°, and at B, for greater lengths.

where

- h = effective antenna height, meters
- λ = wavelength of operation, meters ($= 300/f_{MHz}$)

The *effective height* of the antenna is the height of a theoretical antenna having a constant current distribution all along its length. The area under this current distribution line is equal to the area under the current distribution line of the

“real” antenna. Equation 2 is valid for antennas with a ratio of antenna length to conductor diameter of greater than 500:1 (typical for wire antennas).

For a full-size, quarter-wave antenna the radiation resistance is determined by:

- Current at the base of the antenna = 1 A (given)
- Area under sinusoidal current-distribution curve =

$1 \text{ A} \times 1 \text{ radian} = 1 \text{ A} \times 180/\pi = 57.3 \text{ A-degrees}$
 Equivalent length = 57.3° (1 radian)
 Full electrical wavelength = $300/3.8 = 78.95 \text{ meters}$
 Effective height = $(78.95 \times 57.3)/360 = 12.56^\circ$

$$R_{\text{rad}} = \frac{1450 \times 12.56^2}{78.95^2} = 36.6 \Omega$$

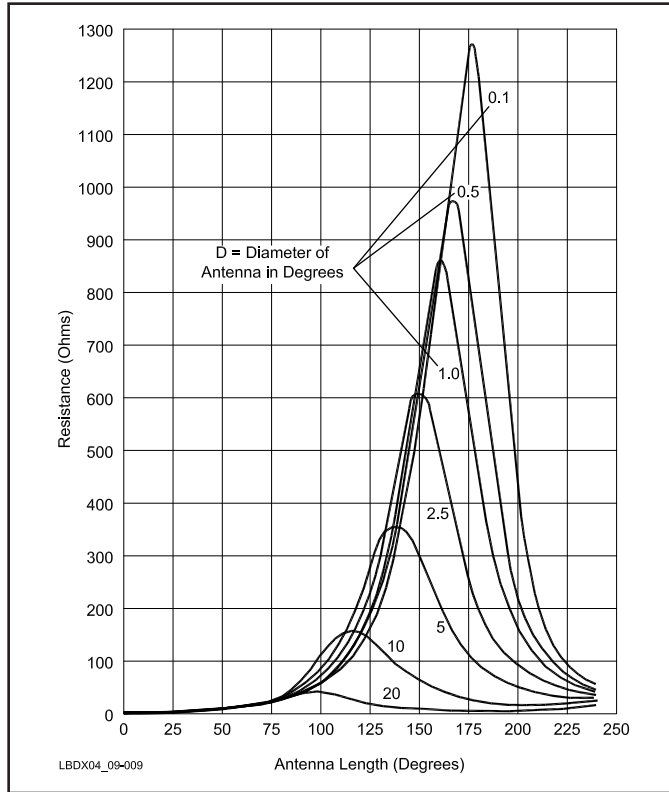

Fig 9-9—Radiation resistances for monopoles fed at the base. Curves are given for various conductor (tower) diameters. The values are valid for perfect ground only.

The same procedure can be used for calculating the radiation resistance of various types of short verticals.

Fig 9-8 shows the radiation resistance for a short vertical (valid for antennas with diameters ranging from 0.1° to 1°). For antennas made of thicker elements, **Fig 9-9** and **Fig 9-10** can be used. These charts are for antennas with a constant diameter.

For verticals with a tapering diameter, large deviations have been observed. W. J. Schultz describes a method for calculating the input impedance of a tapered vertical (Ref 795). It has also been reported that verticals with a large diameter

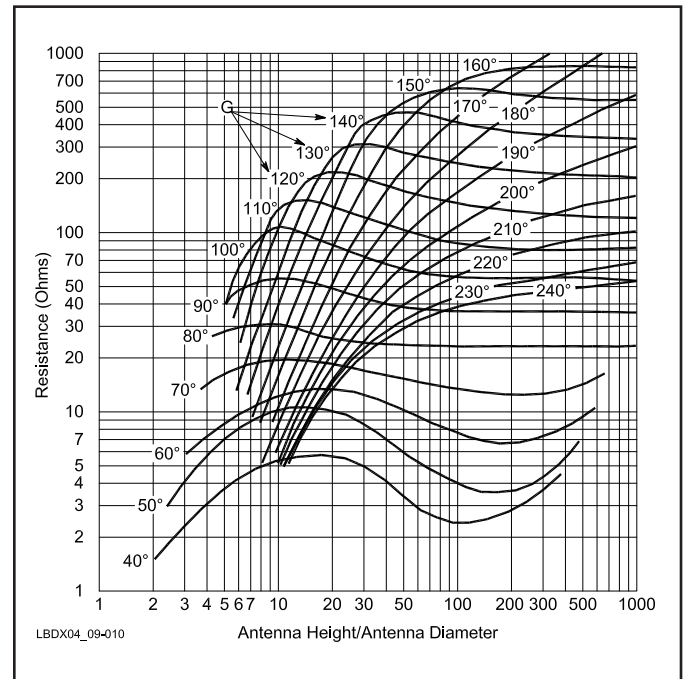

Fig 9-10—Radiation resistances for monopoles fed at the base. Curves are given for various height/diameter ratios over perfect ground.

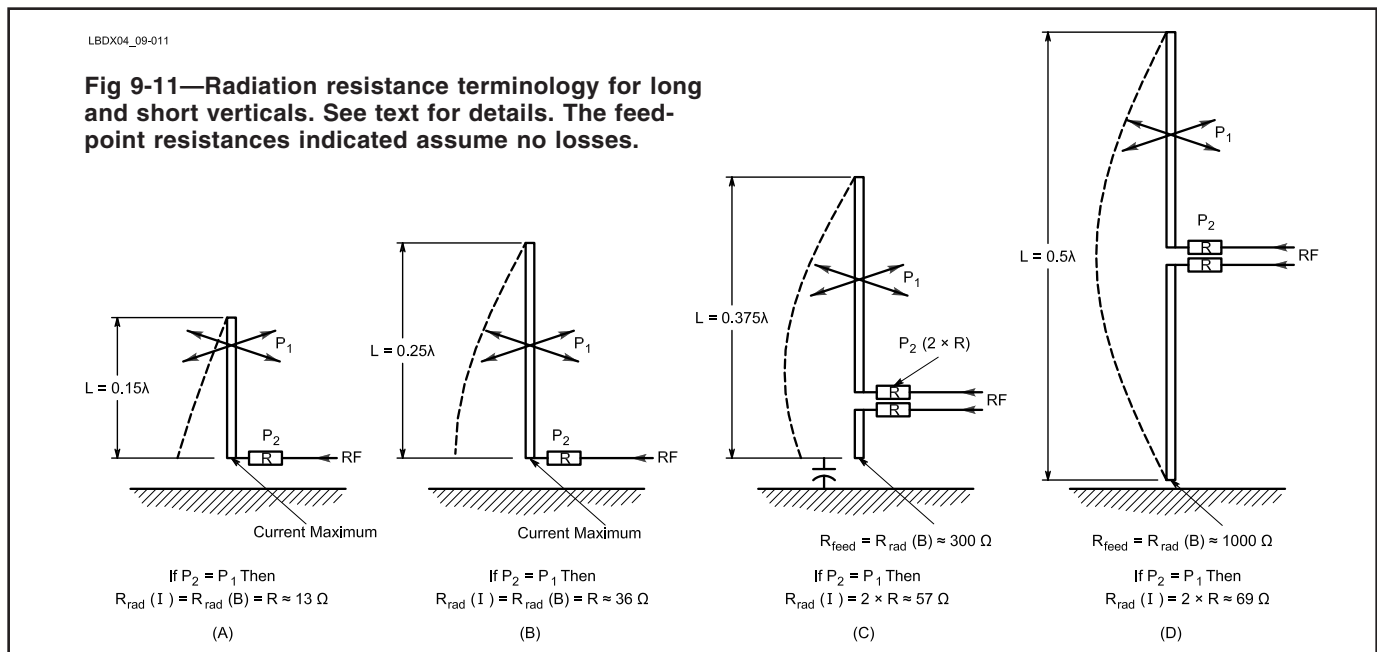

exhibit a much lower radiation resistance than the standard 36.6-Ω value. A. Doty, K8CFU, reports finding values as low as 21 Ω during his extensive experiments on elevated radial systems (Ref 793). I have measured a similar low value on my quarter-wave 160-meter vertical (see Section 6.5.) Section 1.2 shows how to calculate the radiation resistance of various types of short verticals.

Longer vertical monopoles are usually not fed at the current maximum, but rather at the antenna base, so that $R_{rad(I)}$ is no longer the same as $R_{rad(B)}$ for long verticals in Figs 9-9 and 9-10. (Source: Henney, *Radio Engineering Handbook*, McGraw-Hill, NY, 1959, used with permission.) $R_{rad(I)}$ is illustrated in Fig 9-11. The value can be calculated from the following formula (Ref 722):

$$R_{rad(I)} = \varepsilon - 0.7L + 0.1[20 \sin(12.56637L - 4.08407)] + 45 \quad (\text{Eq 9-3})$$

where

ε = the base for natural logarithms, 2.71828 .

L = antenna length in radians (radians = degrees $\times \pi/180^\circ$ = degrees divided by 57.296).

The length must be greater than $\pi/2$ radians (90°).

Fig 9-11C shows the case of a 135° ($3\lambda/4$) antenna. Disregarding losses, $R_{rad(B)} = R_{feed} \approx 300 \Omega$, but the value of $2R$, the theoretical resistance at the maximum current point,

will be lower (57Ω). If P_1 (radiated power) = P_2 (power dissipated in $2R$), then $R_{rad(I)} = 2R$.

These values of $R_{rad(I)}$ are given in Fig 9-6, while $R_{rad(B)}$ can be found in Figs 9-8 and 9-9. Fig 9-12 and Fig 9-13 show the reactance of monopoles (at the base feed point) for varying antenna lengths and antenna diameters (Source: E. A. Laport, *Radio Antenna Engineering*, McGraw-Hill, NY, 1952, used by permission.)

1.3. Radiation Efficiency of the Monopole Antenna

The radiation efficiency for short verticals has been defined as

$$\text{Eff} = \frac{R_{rad}}{R_{rad} + R_{loss}}$$

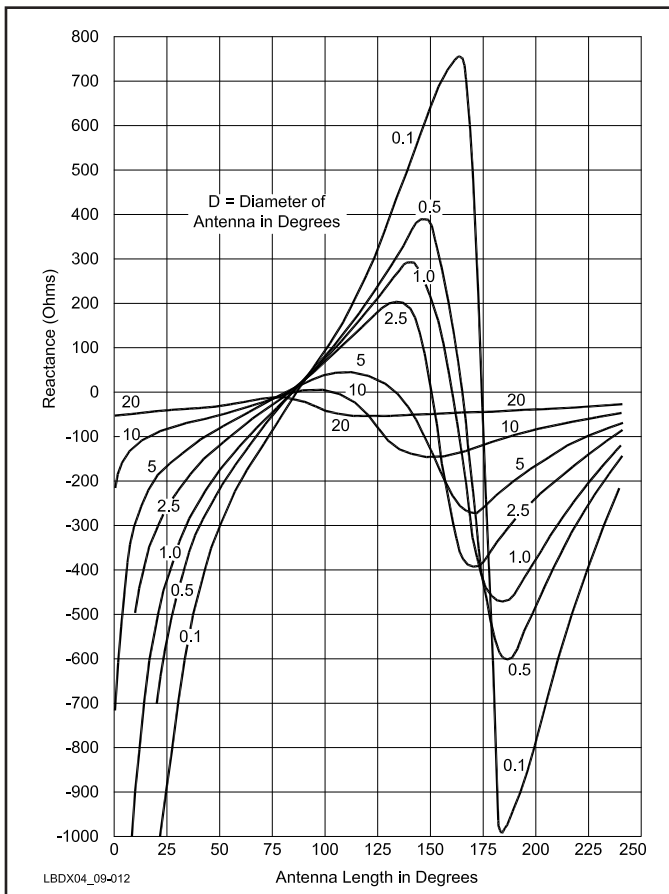

Fig 9-12—Feed-point reactances (over perfect ground) for monopoles with varying diameters.

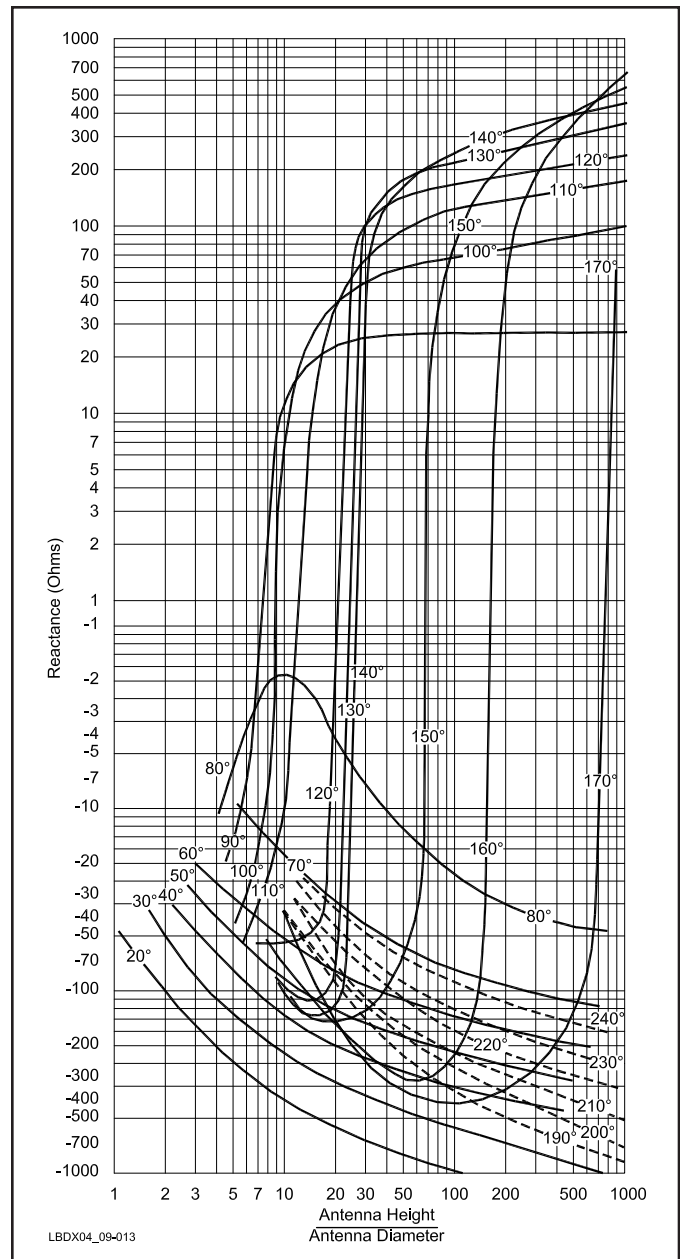

Fig 9-13—Feed-point reactances (over perfect ground) for monopoles with different height/diameter ratios.

For the case of any vertical, short or long, when fed at its base this equation becomes

$$\text{Eff} = \frac{R_{\text{rad}}}{R_{\text{rad(B)}} + R_{\text{loss}}} \quad (\text{Eq 9-4})$$

The loss resistance of a vertical is composed of:

- Conductor RF resistance
- Parallel losses from insulators
- Equivalent series losses of the loading element(s)
- Ground losses part of the antenna current return circuit
- Ground absorption in the near field

1.3.1. Conductor RF resistance

When multisection towers are used for a vertical antenna, care should be taken to ensure proper electrical contact between the sections. If necessary, a copper braid strap should interconnect the sections. Rohrbacher, DJ2NN, provided a formula to calculate the effective RF resistance of conductors of copper, aluminum and bronze:

$$R_{\text{loss}} = (1 + 0.1 L) \left(f^{0.125} \right) \left(0.5 \frac{1.5}{D} \right) \times M \quad (\text{Eq 9-5})$$

where

L = length of the vertical in meters

f = frequency of operation in MHz

D = conductor diameter in mm

M = material constant (M = 0.945 for copper, 1.0 for bronze, and 1.16 for aluminum)

1.3.2. Parallel losses in insulators

Base insulators often operate at low-impedance points. For monopoles near a half-wavelength long, however, care should be taken to use high-quality insulators, since very high voltages can be present. There are many military surplus insulators available for this purpose. For medium and low-impedance applications, insulators made of nylon stock (turned down to the appropriate diameter) are excellent, but a good old Coke bottle may do just as well!

1.3.3. Ground losses

Efficiency means: How many of the watts I deliver to the antenna are radiated as RF. Effectiveness means: Is the RF radiated where I want it? That is, at the right elevation angle and in the right direction. Your antenna can be very efficient but at the same time be very ineffective. Even the opposite is possible (killing a mouse with an A-bomb).

A large number of articles have been published in the literature concerning ground systems for verticals. The ground plays an important role in determining the efficiency as well as effectiveness of a vertical in two very distinct areas: the near field and the far field. Losses in the near field are losses causing the radiation efficiency to be less than 100%.

- **I²R losses:** Antenna return currents travel through the ground, and back to the feed point, right at the base of the antenna (see Fig 9-41). The resistivity of the ground will play an important role if these antenna RF return currents travel through the (lossy) ground. Unless the vertical antenna uses elevated radials, the antenna return current will flow through the ground. These currents will cause

I²R losses. Even for elevated radials, return currents can partially flow through the ground if a return path exists (can be by capacitive coupling if raised radials are close to ground). With a small elevated system, loss increases with any RF ground path at the antenna base, including the path back by the coax shield. This why the feed line should be decoupled for common modes at the antenna feed point with an elevated radial system.

- **Absorption losses:** The conductivity and the dielectric properties of the ground will play an important role in absorption losses, caused by an electromagnetic wave penetrating the ground. These losses are due to the interaction of the near-field energy-storage fields of the antenna (or radials) with nearby lossy media, such as ground. These types of losses are present whether elevated radials are used or not. The radials should shield the antenna from the lossy soil and distribute the field evenly around the antenna. Most often elevated radials don't help much here, since they normally aren't dense enough to make an effective screen. Four radials are far from a screen! The field is concentrated near the radials, and other areas are directly exposed to the antenna's induction fields.

In the far field (efficiency and effectiveness issues):

- Up to many wavelengths away, the waves from the antenna are reflected by the ground and will combine with the direct waves to form the radiation at low angles, the angles we are concerned with for DXing. The reflection mechanism, which is similar to the reflection of light in a mirror is described in Section 1.1.2. The real part of the reflection coefficient determines what part of the reflected wave is absorbed. The absorbed part is responsible for Fresnel-zone reflection losses (efficiency).
- The ground characteristics in the Fresnel zone will also determine the low-angle performance of the vertical, and this is an effectiveness issue.

The effect of ground in these two different zones has been well covered by P. H. Lee, N6PL (Silent Key), in his excellent book, *Vertical Antenna Handbook*, p 81 (Ref 701). The next section will cover these and various other aspects of the subject.

2. GROUND AND RADIAL SYSTEM FOR VERTICAL ANTENNAS: THE BASICS

2.0.1. Ground-plane antennas

We all know that a VHF vertical antenna usually employs four radials as a "ground-plane," hence its popular name. But in fact, two radials would do the same job. All you need with a $\lambda/4$ vertical radiator is a $\lambda/4$ wire connected to the feed-line outer conductor in order to have an RF ground at that point. The radial provides the other terminal for the feed line to "push" against. Unless the feed line is radiating, you will have exactly the same current into the radial (system) as you have in the form of common-mode current exciting the vertical. That is the "push against" effect of the radials. This is also how the antenna return currents are collected.

But if you have only one radial, this radial would radiate a horizontal wave component. Two $\lambda/4$ radials in a straight line have their current distributed in such a way that radiation from the radials is essentially canceled in the far field, at least in an ideal situation. This is similar to what happens with top-

wire loading (T antennas). Using three wires (at 120° intervals) or four radials at right angles does the same also.

It was George Brown himself, Mr 120-buried-radials, who invented elevated resonant radials. He invented the ground-plane antenna. The story goes that when Brown first tried to introduce his ground-plane antenna it had only two radials, but he had to add two extra radials because few of his customers believed that with only two radials the antenna would radiate equally well in all directions! In the case of a VHF ground plane mounted at any practical height above ground, there is no “poor ground” involved and all return currents are collected in the form of displacement currents going through the two, three or four radials.

The VHF case is where detrimental effects of real ground are eliminated by raising the antenna high above ground, electrically speaking. There are no I²R losses, because the return currents are entirely routed through the low-loss radials. There also are no near-field absorption losses, since the real ground is several wavelengths away from the antenna. Third, on VHF/UHF we are not counting on reflection from the real earth to form our vertical radiation pattern; we are not confronted by losses of Fresnel reflection in the far field either. In other words, we have totally eliminated poor earth.

2.0.2. Verticals with an on-ground (or in-ground) radial system

The other approach in dealing with the poor earth is going to the other extreme—bring the antenna right down to ground level, and, by some witchcraft, turn the ground into a perfect conductor. This is what you try to do in the case of grounded verticals.

You can put down radials, or strips of “chicken wire” to improve the conductivity of the ground, and to reduce the I²R losses as much as possible. This mechanism is well-known. You can also measure its effect: You know that as you gradually increase the number and the length of radials, the feed-point impedance is lowered, and with a fairly large number of long radials (for example, 120 radials, $\lambda/2$ long) you will reach the theoretical value of the radiation resistance of the vertical. In the worst case, when no measures are taken to improve ground conductivity, losses can be incurred that range from 5 to well over 10 dB with $\lambda/4$ long radiators, and much higher with shorter verticals.

The other mechanism—absorption by the lossy earth—is less well-known in amateur circles. This is partly because you cannot directly measure its effects (see also Section 2.4), as you can for I²R losses. But the effect is nevertheless there and can result in 3 to 6 dB of signal loss, if not properly handled. For a ground-plane antenna you can improve the situation by moving the near field of the antenna well above ground. For a vertical with its base less than about $3\lambda/8$ above ground you can screen (literally hiding) the lossy ground from the near field of the antenna.

This means that in the case of buried or on-the-ground radials, their number and length must be such that the ground underneath is effectively made invisible to the antenna. It has been experimentally established that for a $\lambda/4$ vertical you must use at least $\lambda/4$ -long radials, in sufficient number so that the tips of the radials are separated no more than 0.015λ (1.2 meters on 80 meters and 2.4 meters on 160 meters). This means approximately 100 radials to achieve this goal. With

half that number, you will lose approximately 0.5 dB due to near-field absorptive losses—This is RF “seeping” through an imperfect ground screen. In real life, taking good care of the I²R losses with buried radials also means taking good care of the near-field absorption losses.

2.0.3. Verticals with a close-to-earth elevated radial system

In some cases it is difficult or impossible to build an on-the-ground radial system that meets this requirement, in most cases because of local terrain constraints. In this case a vertical with a radial system *barely* above ground may be an alternative. The question is: how good is this alternative and how should we handle this alternative? With radials at low height (typically less than 0.1λ above ground) you still must deal with effectively collecting return currents and with absorption losses in the real ground.

It is clear that if you raise an almost-perfect on-ground radial system higher above ground should yield an almost-perfect elevated-radial system. The perfect on-ground system would consist of 50 to 100 $\lambda/4$ -long radials. In fact, the screening effect that is good for radials laying directly *on* the lossy ground, will be even better if the system is raised somewhat above ground. That the screening of such a dense radial system is close to 100% effective was witnessed by Phil Clements, K5PC, who reported on the Internet that while walking below the elevated radial system (120 elevated radials) of a BC transmitter in Spokane, Washington, he could hardly hear the transmitted signal on a small portable receiver. The question, of course, is: Do we really need so many elevated radials, or can we live with many less? This question is one of the topics that I deal with in detail in Section 2.2 on elevated radial systems.

When dealing with the antenna return currents, it is clear that simple radial systems (in the most simple form a single radial) can be used. This has proven true for ages in VHF and UHF ground planes. The only issue here is the possible radiation of these radials in the far field, which could upset the effective radiation pattern of the antenna. This will also be dealt with in Section 2.2.

2.1. Buried Radials

Dr Brown’s original work (Ref 801) on buried ground-radial systems dates from 1937. This classic work led to the still common requirement that broadcast antennas use at least 120 radials, each at least 0.5λ long.

2.1.1. Near-field radiation efficiency

The effect of I²R losses can be assessed by measuring the impedance of a $\lambda/4$ vertical, as a function of the number and length of the radials. Many have done this experiment. **Table 9-1** shows the equivalent loss resistance computed by deducting the radiation resistance from the measured impedance.

2.1.2. Modeling buried radials

Antenna modeling programs based on *NEC-3* or later can model buried radials. These programs address both the I²R losses and the absorption losses in the near field, plus of course any far-field effects. These powerful new tools can be dangerous. They would make you believe you can now model everything, and that there is no need for validation. In the real

Table 9-1
Equivalent Resistances of Buried Radial Systems

Radial Length (λ)	Number of Radials				
	2	15	30	60	120
0.15	28.6	15.3	14.8	11.6	11.6
0.20	28.4	15.3	13.4	9.1	9.1
0.25	28.1	15.1	12.2	7.9	6.9
0.30	27.7	14.5	10.7	6.6	5.2
0.35	27.5	13.9	9.8	5.6	2.8
0.40	27.0	13.1	7.2	5.2	0.1

Table 9-2
Wave Angle and Pseudo-Brewster Angle for Ground-Mounted Vertical Antennas Over Different Grounds.

The Wave angle and the Pseudo Brewster angle are essentially independent of the radial system used, unless the radials are several wavelengths long.

Band/Ground Type	Wave Angle	Pseudo-Brewster Angle
80 meters		
Very Poor Ground	29°	15.5°
Average Ground	25°	12.5°
Very Good Ground	17°	7.0°
Sea Water	8.5°	1.8°
160 meters		
Very Poor Ground	28°	14.5°
Average Ground	23°	11°
Very Good Ground	19.5°	8.5°
Sea Water	8.5°	7.0°

world, mainly due to the non-homogeneous nature of the ground surrounding our antennas, the slight variations we sometimes see from modeling results (many authors would rank modeled ground systems by quoting gains specified to a 1/100 of a dB!) are totally meaningless. At best modeling under such circumstances indicates a trend. Let's have a look at these trends.

R. Dean Straw, N6BV, ran a large number of models using *NEC-4* for me (*NEC-4* is not available to non-US citizens). Separate computations were done for 80 and 160 meters. The radiators were $\lambda/4$ long and the radials were buried 5 cm in the ground. The variables used were:

- Ground: very poor, average, very good
- Radial length: 10, 20 and 40 meters (for 80 meters), and 10, 40 and 80 meters (for 160 meters)
- Number of radials: 4, 8, 16, 32, 64 and 120.

We computed the gain, the elevation angle and the pseudo-Brewster angle. Although we ordinarily talk about $\lambda/4$ buried radials, buried radials by no means must be resonant. A $\lambda/4$ wire that is resonant above ground, is no longer resonant in the ground—not even on or near the ground. Typically for a wire on the ground, the physical length for $\lambda/4$ resonance will be approximately 0.14λ and the exact length depending on ground quality and height over ground.

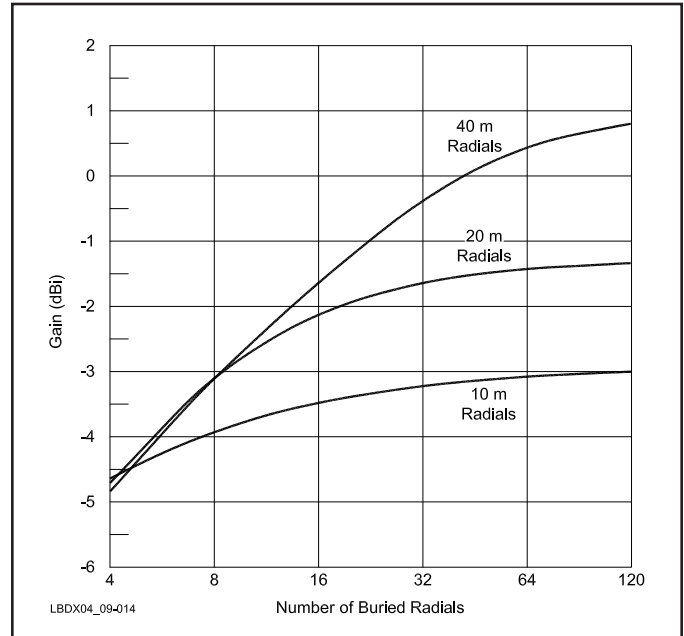

Fig 9-14—Gain of 0.25λ 80-meter vertical over very poor ground as a function of radial length and number of radials. For short (10-m long) radials there is not much point in going above 16 radials. With 20-m radials you are within 0.5 dB of maximum gain with 32 radials. If you want maximum benefit from 0.5λ radials (40 m), 120 radials are for you.

Quarter-wave radials, in the context of buried radials, are wires measuring $\lambda/4$ over ground (typically 20 meters long on 80 meters and 40 meters on 160 meters).

The gains of the modeling are shown in **Figs 9-14 through 9-19**. The wave angle as well as the Brewster angle are almost totally independent of the radial system in the near field. The values are listed in **Table 9-2**.

When modeling the antenna over poor ground using only four buried radials, it was apparent that the gain was slightly higher using 15-meter long radials rather than 20 meter or even 40-meter long radials (the gain difference being 0.7 dB, quite substantial). It happens that the resonant length of a $\lambda/4$ radial in such lossy ground is 10 to 15 meters (and not \approx 20 meters as it would be in air). In case of a small number of radials, there is hardly any screening effect, and antenna return currents flow back through lossy, high-resistance earth to the antenna, as well as through the few radials. There are

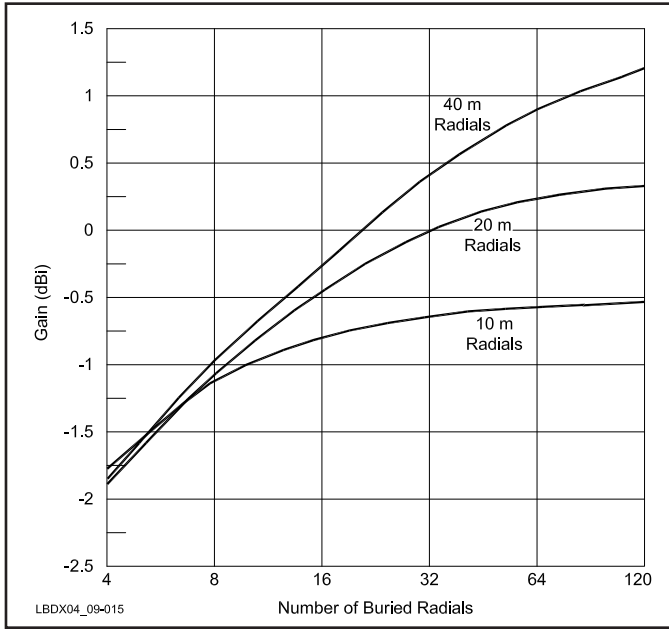

Fig 9-15—Gain of a $\lambda/4$ 80-meter vertical over average ground, as a function of radial length and number of radials. Note that for 10-meter long radials there is practically no gain beyond about 52 radials. For quarter wave radials there is little to be gained beyond 104 radials, and the difference between 26 $\lambda/4$ radials and 104 $\lambda/4$ radials is only 0.5 dB. These are exactly the same number N7CL came up with by experiment (see Section 2.1.3).

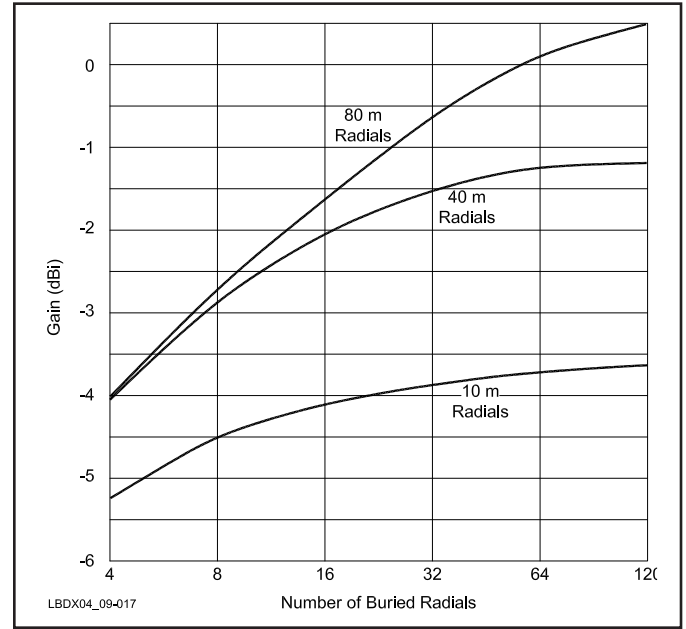

Fig 9-17—Gain of $\lambda/4$ 160-meter vertical over very poor ground as a function of radial length and number of radials. Note that 10-meter radials, no matter how many, are really too short for 160 meters.

two parallel return circuits: a low-resistance one (the radials) and a high-resistance one (the lossy ground). If the radials are made resonant, their impedance at the antenna feed point will be low, thereby forcing most of the current to return through the few radials. If the impedance is high (such as with 20- or 40-meter long radials), a substantial part of the return currents

can flow back through the lossy earth. (See Section 2.1.3.) The same phenomenon is marginally present with radials in average ground as well, but has disappeared completely in good ground. These observations tend to confirm the mechanism that originates this apparent anomaly. All of this is of no real practical consequence, since four radials are largely insufficient, in whatever type of ground (except saltwater).

We also modeled radials in seawater. As expected, one radial does just as well as any other number. All we really need

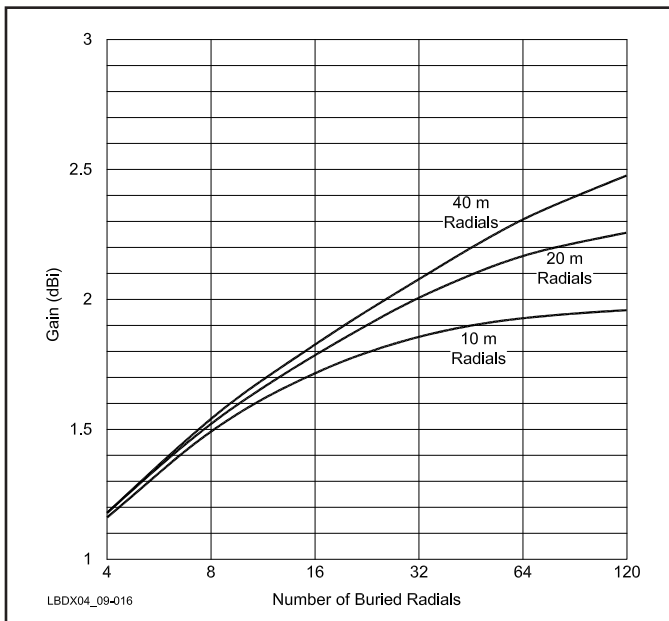

Fig 9-16—Gain of $\lambda/4$ 80-meter vertical over very good ground as a function of radial length and number of radials.

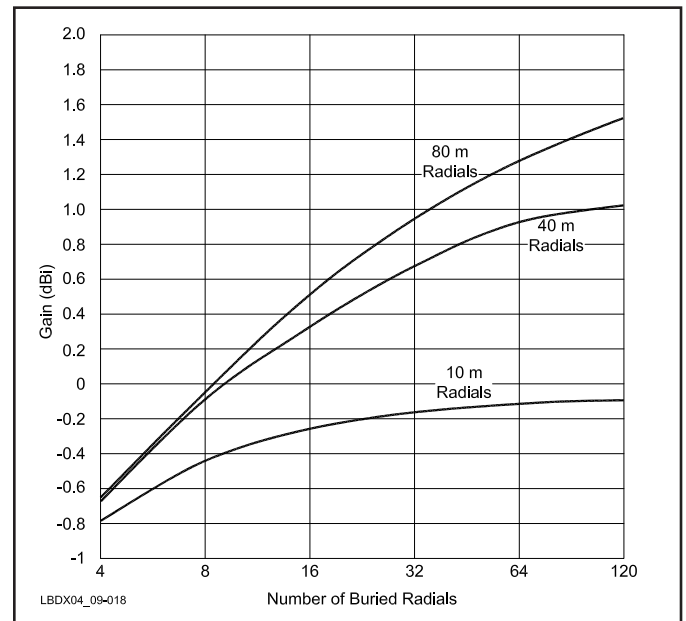

Fig 9-18—Gain of $\lambda/4$ 160-meter vertical over average ground as a function of radial length and number of radials.

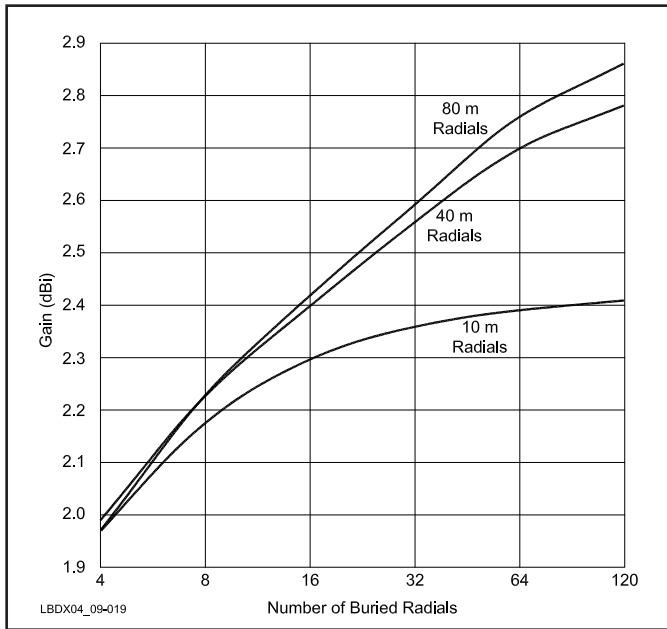

Fig 9-19—Gain of $\lambda/4$ 160-meter vertical over very good ground as a function of radial length and number of radials. The $\lambda/2$ radials are really a waste over very good ground.

is to connect the base of the vertical to the almost-perfect conductor (and screen) that the seawater represents. See **Fig 9-20** for a fantastic saltwater location.

Years ago Brian Edward, N2MF, modeled the influence of buried radials (Ref 816), and discovered that for a given number of radial wires, there is a corresponding length beyond which there is no appreciable efficiency improvement. This corresponds very well with what we find in Figs 9-14 through 9-19. Brian found that this length is (maybe surprisingly at first sight) nearly independent of earth conditions. This indi-



Fig 9-20—XZ0A had an ideal location for far-field reflection efficiency: Saltwater all around. Four Squares were used on 80 and 160 meters, resulting in signals up to S9+20 dB in Europe on Topband, quite extraordinary from that part of the world.

**Table 9-3
Optimum Length Versus Number of Radials**

Number of Radials	Optimum Length (λ)
4	0.10
12	0.15
24	0.25
48	0.35
96	0.45
120	0.50

This table considers only the effect of providing a low-loss return path for the antenna current (near field). It does not consider ground losses in the far field, which determine the very low-angle radiation properties of the antenna.

cates that it is the screening effect that is more important than the return-current I^2R loss effect. Indeed, the effectiveness of a screen only depends on its geometry and not on the quality of the ground underneath. **Table 9-3** shows the optimum radial length as a function of the number of radials. This was also confirmed through the experimental work by N7CL (see Section 2.1.3).

Conclusion

To me, the results obtained when modeling verticals using buried radials with NEC-4 seem to be rather optimistic, but the trends are clearly correct. Take the example of an 80-meter vertical over average ground: going from a lousy eight 20-meter long radials to 120 radials would only buy you 1.4 dB of gain, which is less than what I think it is in reality. In very good ground that difference would be only 0.7 dB!

There has been some documented proof that NEC-4 does not handle very low antennas correctly, and that the problem is a problem associated with near-field losses (see Section 2.2.2). Maybe this same limitation of NEC-4 causes the gain

figures calculated with buried radials to be optimistic as well. The future will tell. No doubt further enhancements will be added to future NEC releases, which may well give us gain (loss) figures that I would feel more comfortable with for verticals with buried radials.

2.1.3. How many buried radials now, how long, what shape?

When discussing radial lengths, I usually talk about $\lambda/4$ or $\lambda/8$ radials. Mention of a $\lambda/4$ radial leads most of us to think of a 20-meter long radial on 80 meters. A wire up in the air at heights

where you normally have an antenna has a velocity factor (speed of travel vs speed of light) of about 98%. When you bring that same wire close to ground, the velocity factor starts dropping rapidly below a height of about 0.02 wavelength. On the ground, the velocity factor is on the order of 50-60%, which means that a radial that is physically 20 meters long is actually a half-wave long electrically! (See also Fig 9-32.)

If you use just a few on-the-ground radials over poor ground, the radials may act like they are somewhat resonant. The resonance vanishes if you have many radials or if the ground is good to excellent. For these cases it is best to use radials that are an *electrical* quarter-wave long. On 80 meters you should use 10-meter long radials, and on 160 meters you should use 20-meter long radials if you are only using a few (up to four). But that's bad practice anyhow: Four is far too few radials.

As soon as you use a larger number of equally spread radials the resonance effect disappears, and the radials form a disk, which becomes a screen with no resonance characteristics. In this case we no longer talk about length of radials but about the diameter of a disk hiding the lossy ground from the antenna.

Assume we have 1 km of radial wire and unrestricted space. How should we use it? Make one radial that is 1000 meters long, or 1000 radials that are 1 meter long? It's quite obvious the answer is somewhere in the middle.



Fig 9-21—The Battle Creek Special that made Heard Island available on 160 for over 1000 different stations. Ghis, ON5NT, is not holding up the antenna; it is very well capable of standing up by itself. The antenna was located near the ocean's edge, on saltwater-soaked lava ash.

2.1.3.1. Early work

Brown, Lewis, and Epstein in the June 1937 Proceedings of the IRE published measured field strength data at 1 miles (versus number and length of radials). Measurements were done at 3 MHz. The measured field strength was converted to dB vs the maximum measured field strength (for 113 radials of 0.411λ).

2.1.3.2. Some observations

- For short radials (0.137λ), there is negligible benefit in having more than 15 radials.
- For radial lengths of 0.274λ and greater, continuous improvement is seen up to 60 radials. Note that doubling the number and doubling the length of radials from the above case (15 short radials of 0.137λ) only gains 1 dB greater field strength, with four times the total amount of wire.
- Lengthening radials 50% from 0.274λ to 0.411λ and keeping the same number hardly represents an improvement (0.24 dB). Raising the number to 113 radials represents a gain of 0.66 dB over the second case, but uses nearly three times as much wire.

From these almost 70-year-old studies, we can conclude that 60 quarter-wave long radials is a cost-effective optimal solution for amateur purposes. The following rule was experimentally derived by N7CL and seems to be a very sound and easy one to follow. Put radials down in such a way that the distance between their tips is not more than 0.015λ . This is 1.3 meters for 80 meters and 2.5 meters on 160 meters.

The circumference of a circle with a radius of $\lambda/4$ is $2 \times \pi \times 0.25 = 1.57 \lambda$. At a spacing of 0.015λ at the tips, this circumference can accommodate $1.57/0.015 = 104$ radials. With this configuration you are within 0.1 dB of maximum gain over average to good ground. If you space the tips 0.03λ you will lose about 0.5 dB.

For radials that are only $\lambda/8$ long, a $0.03\text{-}\lambda$ tip spacing requires 52 radials. Here too, if you use only half that number, you will give up another 0.5 dB of gain. In general, the number that N7CL came by experimentally, closely follow those from Brown, Lewis and Epstein. Let us apply this simple rule to some real-world cases:

Example 1

Assume your lot is 20 by 20 meters and that you want to install a radial system for 80 and 160 meters. Draw a circle that

**Table 9-4
From Brown, Lewis and Epstein
Signal Strength vs Length of Radials in Wavelengths**

Number Radials	Length 0.137λ	Length 0.274λ	Length 0.411λ
2	-4.36	-4.36	-4.05 dB
15	-2.4	-1.93	-1.65 dB
30	-2.4	-1.44	-0.97 dB
60	-2.0	-0.66	-0.42 dB
113	-2.0	-0.51	0 dB (Ref)

fits your lot. This circle has a radius of

$$\sqrt{20^2} / 2 = 14 \text{ meters}$$

On each 20-meter side of your lot you would space the ends evenly by 1.3 meters. This means you can fit 16 radials on your property. The longest will be 14 meters; the shortest will be 10 meters long. The average radial length is 12 meters. You can install a total of $16 \text{ (radials)} \times 4 \text{ (sides)} \times 12 \text{ meters (average length)} = 768 \text{ meters}$ of radial wire, with a total of 64 radials. A radial system using 32 evenly spread radials, and using only 385 meters of wire, would compromise your system by about 0.5 dB.

In actual practice, when laying radials on an irregular lot where the limits are the boundaries of the lot, the most practical way to make best use of the wire you have is just walk the perimeter of the lot and start a radial from the perimeter (inward toward the base of the antenna) every 0.015λ (1.3 meters for 80 meters or 2.5 meters for 160) as you walk along the perimeter.

Example 2

You have only 500 meters of wire and space is not a problem. How many radials and how long should they be to be used on both 80 and 160 meters?

The formula to be used is:

$$N = \frac{\sqrt{2 \times \pi \times L}}{A} \quad (\text{Eq 9-6})$$

where

N = number of radials

L = total wire length available

A = distance between wire tips (1.3 meters for 80, 2.5 meters for 160, or twice that if 0.5 dB loss is tolerated).

For this example use $L = 500 \text{ meter}$, $A = 1.3 \text{ meters}$, and you calculate:

$$N = \frac{\sqrt{2 \times \pi \times 500}}{1.3} = 43 \text{ radials.}$$

Each radial will have a length of $500/43 = 11.6 \text{ meters}$.

You could also use $A = 2.6 \text{ meters}$, in which case you wind up with 22 radials, each 18 meters long. However, the first solution will give you slightly less loss.

For a given length of wire, it is better to use a larger number of short radials than a smaller number of long radials, the limit being that the tips should not be closer than 0.015λ .

Example 3

How much radial wire (number and length) is required to build a radial system (for a $\lambda/4$ vertical) that will be within 0.1 dB of maximum gain. How much to be within 0.5 dB?

The answer to the first question is 104 radials, each $\lambda/4$ long. The total wire length for 80 meters is: 2080 meters (4000 meters for 160). With 52 radials, each $\lambda/4$ long, you are within 0.5 dB of maximum gain. This translates to 1000 meters of radial wire required for 80 meters and 2000 meters for 160 meters.

Example 4

I can put down 15-meter long radials in all directions. How many should I put down, and how much radial wire is required?

The circumference of a circle with a radius of 15 meters is: $2 \times \pi \times 15 = 94.2 \text{ meters}$. With the tips of the radials separated by 1.3 meters, we have $94.2/1.3 = 72 \text{ radials}$. In total I would use $72 \times 15 = 1080 \text{ meters}$ of radial wire. There is no point in using more than 72 radials.

2.3.1.3. K3NA's work

In private correspondence ("Effects of Ground Screen Geometry on Verticals"), Eric Scace, K3NA, explained a simple rule of thumb he derived from an extensive modeling study he conducted using *NEC-4.1*. His conclusions are applicable for radials up to $3\lambda/8$ in length:

- Measure R, the real component of the feed-point impedance.
- Double the number of radials.
- Measure R again.
- Continue doubling the number of radials until R changes by less than 1Ω .

K3NA's detailed modeling study to evaluate the effectiveness of various radial configurations was similar to what N6BV did years ago for the Third Edition of this book. The main difference between the two studies is that K3NA calculated the gain versus the total amount of radial wire used for different configurations. He calculated the "sky Gain" (Gsky) to assess the quality of the radial system. Gsky is the total power radiated to the entire sky, covering all elevation angles, all azimuths. K3NA was concerned with two aspects: the *efficiency* issue, which is related to the task of collecting return currents in the vicinity of a lossy ground and doing so with the smallest possible losses. (See definitions in Section 1.3.3.) The second issue is that of *effectiveness*, which means putting the radiated power where we want it. For a single

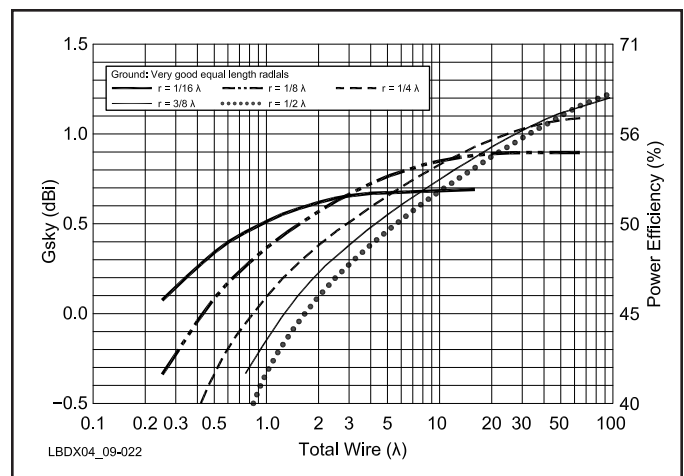

Fig 9-22—Total sky-gain results over very good ground for various radial systems using standard radials, shaped as the spokes of a wheel. The graph shows that with small amounts of wire, many short radials are the answer. It also tells us that 10λ of radial wire used to make $80 \lambda/8$ radials is only 0.2 dB down from 30λ of radial wire used to make $120 \lambda/4$ radials.

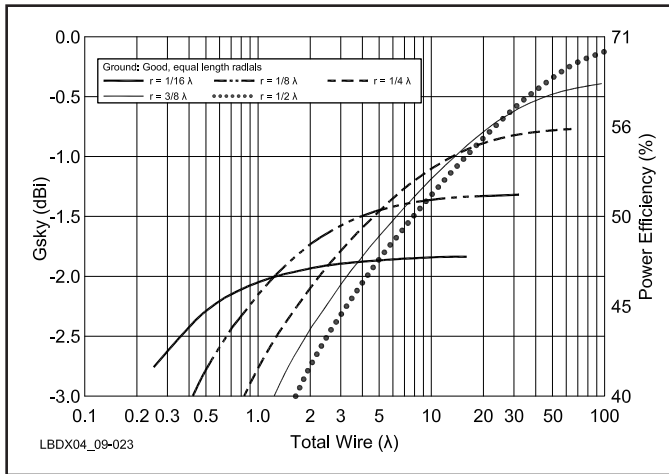

Fig 9-23—The same graph as in Fig 9-22 but for good ground. Unless you only have 4λ of wire, $\lambda/8$ radials are really too short; $\lambda/4$ radials are just fine for up to about 20λ of wire (this about 3.3 km or 10,000 ft of radials on 160 meters). Notice that this study also shows that there is little to be gained beyond approximately $100 \lambda/4$ radials. $300 \lambda/2$ radials only gain about 0.7 dB (a power increase of only 20%) over $100 \lambda/4$ radials—not really a whole lot!

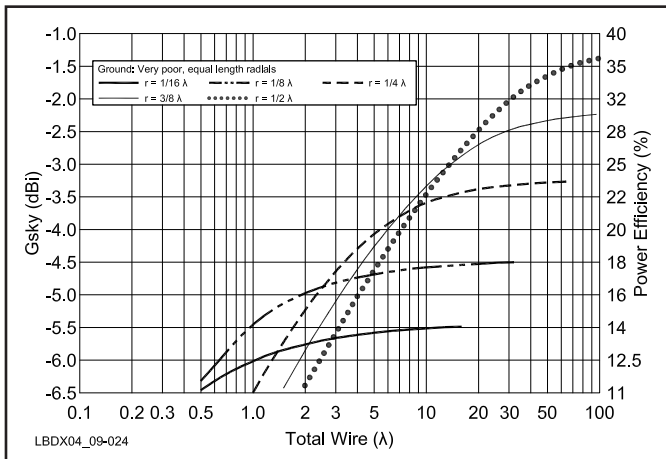

Fig 9-24—Have a look at the gain axis: No matter what you do (lots of $\lambda/2$ long radials), -1.3 dBi is the limit for very poor ground (as compared to 0 dBi for good ground and approximately $+1.5$ dB over very good ground). The nearly 3-dB difference is due to the Fresnel-zone reflection efficiency.

vertical this means obtaining appropriate vertical angles of radiation, which is actually formed in the far field by the combination of the direct and the reflected waves.

2.3.1.3.1. Over very good ground

K3NA used as a starting point in his studies the available quantity of radial wire. For up to 3λ of available wire, the most efficient solution is to use $\lambda/16$ radials, even if there is space for longer ones. Beyond 48 radials, he found hardly any improvement. This confirms what we show in Fig 9-16. Not everything in his study is however a perfect match the modeling results done several years ago by N6BV.

Figs 9-22 through 9-24 show the results for very good ground, good ground and very poor ground respectively. These confirm that any improvement in efficiency by improving the radial system improves radiation at all elevation angles equally. For regular-shaped radials laid out as the spokes of a wheel K3NA came to the conclusion that N7CL's rule of thumb, which says to separate the tips of the radials by no more than 0.015λ , is confirmed by modeling, at least for radials up to $\lambda/4$ in length.

2.3.1.3.2. Other configurations

K3NA also investigated the possibility of using radials that split out along their way: fork-shaped radials. He found out that for a given amount of available wire, these fork-type radials do not perform any better than regular straight radials.

A third alternative he examined was alternating long ($\lambda/4$) and short ($\lambda/8$) radials. Here too this radial geometry reduces Gsky compared to a system using the same total length of radial wire used as uniform-length straight radials.

Eric went on to assess the performance of ground screens in square and triangular grids. Here again, for a given amount of radial wire, the performance did not meet that of a classical radial configuration.

Looking at all these very detailed modeling results you must ask yourself: "Is it really like this in real life?" We are playing with very minute changes in inputs and obtaining even smaller changes in results. Can you really trust these models? Earth is a very difficult thing to model, and it is very non-homogeneous.

It's obvious that we should be conscious of trends, and the modeling results confirm the trends revealed by N7CL's experimental work. There's an even simpler rule: Put in as many radials as you can, until you feel satisfied. If you think you can do better, do better. If you think "this is as far as I can go," be happy with it!

Tom, W8JI, wrote this interesting observation for the Topband reflector: "Even a very small limited space antenna like an inverted L will do very well if some effort is put into the ground system. My friend K8GIJ was always within a few dB of my signal (I used a $1/4 \lambda$ vertical tower with 100 radials), and all he had was a 15 by 100 ft back yard! But then Harold filled his small yard with radials, and even tied the fences and everything else in to his ground system." So, you guys on a city size lot, there is no reason not to be loud on 160 meters.

Of course, to be able to *hear* as well as Tom, W8JI, is another challenge.

2.1.4. Two-wavelength-long radials and the far field

Everything that happens in the near field determines the radiated field strength in the far field. Radials, screens, and I^2R losses have very little influence on the radiation pattern of the vertical, except maybe at very high angles, which don't interest us anyhow. Any method of improving ground conductivity in the near field (up to $\lambda/4$ from the base of a $\lambda/4$ vertical) improves the entire radiation pattern, not just favoring certain radiation angles more than others.

In the far field, however, ground characteristics greatly influence the low-angle characteristics of a vertical antenna. For $\lambda/4$ verticals the area where Fresnel reflection occurs starts about 1λ from the antenna and extends to a number of wavelengths.

For current collecting and near-field screening there is really no point in installing radials longer than $\lambda/4$. With 104 such radials you are within 0.1 dB of what is theoretically possible. The Brown rule (120 radials, $0.5\text{-}\lambda$ long) shoots for less than 0.1 dB and has some extra reserve built in.

If you want to influence the far field and pull down the radiation angle somewhat, or reduce the reflection loss, then we are talking about radials that are about 2λ long. For this you would need a terrain measuring 660×660 meters (43 hectares or 100 acres) for Topband, which is hardly practical, of course.

The only practical way to influence the far-field reflection efficiency and effectiveness is to install your vertical in the middle of saltwater. In that case you will have a peak radiation angle of between 5 and 10° and a pseudo-Brewster angle of less than 1° ! The elevation pattern becomes very flat, showing a -3-dB beamwidth ranging from 1 to 40° . All this is due to the wonderful conductivity properties of saltwater. No wonder such a QTH does wonders!

Tom Bevenham, DU7CC (also SM6CNS), testified: “At my beach QTH on Cebu Island, I use all vertical antennas standing out in salt water. Also, at high tide, water comes all the way underneath the shack. On Topband, I use a folded monopole attached alongside a 105-ft bamboo pole. This antenna is a real winner. I use not much of a ground system, only a few hundred feet of junk wire at sea bottom. At the other QTH, less than half a mile from the beach, the same antennas with ground radials don’t work at all.”

Of course, we have all heard how well the over-saltwater vertical antennas perform. I remember the operation from Heard Island (VKØIR) for one. The Battle Creek Special (see Section 6.6) was standing with its base right in the saltwater.

2.1.5. Ground rods

Ground rods are important for a good dc ground, which is necessary for adequate lightning protection, even if ground rods contribute very little to the RF ground system. If you use a series-fed (insulated-base) vertical, a lightning arrester spark gap with a good dc ground is a good idea. In addition, you can install a 10 to $100\text{-k}\Omega$ resistor or an RF choke between the base of the antenna and the dc ground to drain static charges.

2.1.6. Depth of buried radials

C. J. Michaels, W7XC (Silent Key), calculated the depth of penetration of RF current in different types of ground. He defined the depth of penetration as the depth at which the current density is 37% of what it is at the surface. On 80 meters he calculated a depth of penetration of 1.5 meters for very good ground. For very poor ground the depth reaches 12 meters!

From the point of view of I^2R loss, you can bury the radials “deep” without any ill effects. However, from near-field screening effect point of view, we need to have the radial system above the lossy material.

Bob Leo, W7LR, in Ref 808 reports that burying the radials a few inches below the surface does not detract from their performance. Al Christman, K3LC (ex KB8I), confirmed this when modeling his elevated radial systems using *NEC-4.1*. He found a difference of only hundredths of a dB

between burying radials at 5 cm or 15 cm. I would not bury them much deeper though. The sound rule here is “the closer to the surface, the better.”

2.1.7. Some practical hints

2.1.7.1. Local ground characteristics

It is impossible to make a direct measurement of ground characteristics. The most reliable source of information about local ground characteristics may be the engineer of your local AM broadcast station. The so-called “full proof-of-performance” record will document the average soil conductivity for each azimuth out to about 30 km (20 miles). But unfortunately this is hardly what you need to know. What you need is the ground characteristics in a circle with a $\lambda/4$ radius around the base of your vertical! In your modeling program you plug in a single set of values that supposedly characterize your ground. In the real world, the soil around an antenna is virtually never homogeneous—and almost always not even remotely close to homogeneous. Real-world earth is a widely varying mix of moisture, as well as different types of soil. Because of this, any model that treats the earth as a uniform medium will not be accurate. Verification by field-strength measurement is the only way to know for sure what’s going on!

2.1.7.2. Radial bus-bar/low-loss connections

There are two good ways to collect the currents in the many radials at the base of the vertical. You could use a radial plate (see Fig 9-25) and use stainless-steel hardware to connect the radials. Using solder lugs and stainless steel hardware makes it possible to disconnect the radials so that individual radial-current measurements can be made.

Another method is to make a heavy gauge bus-bar made of a large diameter copper ring, and solder all (copper) radials to the bus (see Fig 9-26).

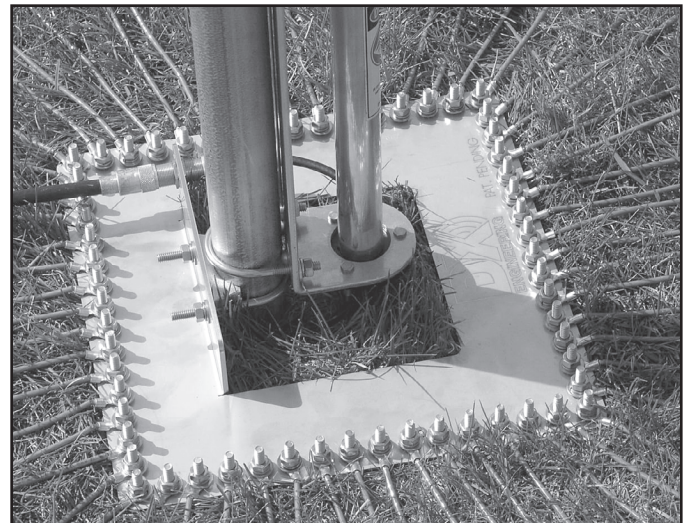

Fig 9-25—The stainless-steel radial plate made by DX-Engineering with 64 holes drilled around its perimeter. All stainless-steel hardware is provided to make a quality radial-connecting system using crimped lugs at the ends of the radials.

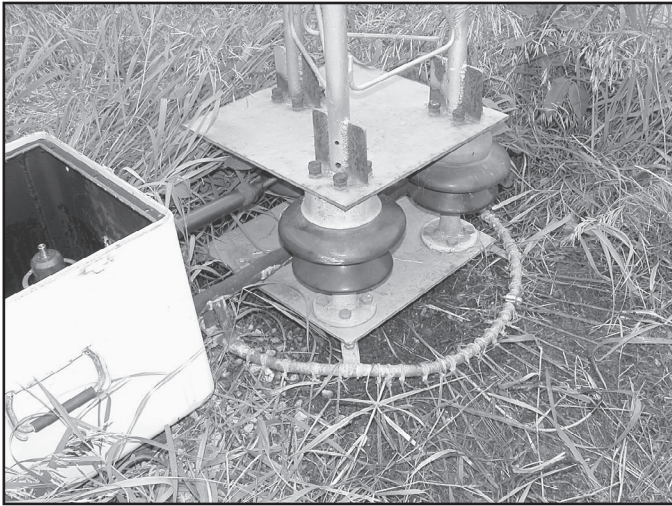

Fig 9-26—W8LRL uses a copper tube (about 10 mm in diameter) bent in a circle, to which he solders all his radials. For a permanent installation this is probably the best way to go, provided you use the correct solder or protect your 60/40 Sn-Pb solder joints with liquid rubber.

2.1.7.3. Soldering/welding radial wires

Tin-lead (Sn-Pb), which is often used to solder copper wires, will deteriorate in the ground and may be the source of bad contacts. Therefore you should silver-solder all copper radials, or even better yet, weld the radials. Information about CADWELD welding products from The RF Connection in Maryland is available on their Web page: www.therfc.com/.

If you decide to use regular 60/40 tin-lead solder, cover all soldered joints with several layers of liquid rubber, so that the acidity of the ground cannot reach the solder joint.

2.1.7.4. Sectorized radial systems

Very long radials (several wavelengths long) in a given direction have been evaluated and found to be effective for lowering the wave angle in that direction, but seem to be rather impractical for just about all amateur installations. A similar effect occurs when verticals are mounted right at the saltwater line. Similar in result to a sectorized radial system is the situation where an elevated radial system is used with only one radial (see Section 2.2.3).

2.1.7.5. Radial wire material

Use copper wire if at all possible. Galvanized-steel wire is a not good, as it has poor conductivity and will rust away in just a few years in wet acidic ground. Aluminum is OK as far as conductivity is concerned but aluminum gradually turns to a white powder as it reacts with the soil. Soldering aluminum wire is not easy, and crimp-on lugs are the only way to go, if you decide to use aluminum.

2.1.7.6. Radial wire gauge

When less than six radials are used, the gauge of the wires is important for maximum efficiency. The heavier the better—#16 wires are certainly no luxury when only a few buried radials are used. With many radials, wire size becomes unimportant since the return current is divided over a large

number of conductors. DXpeditions using temporary antennas often take a small spool of #24 or #26 (0.5 or 0.4-mm diameter) enameled magnet wire. This is inexpensive and can be used to establish a very efficient RF ground system.

2.1.7.7. Bare or insulated wire?

Experience has shown that you can use insulated as well as bare copper wire for buried radials. L.B. Cebik, W4RNL, posted a short paper on this issue on his very informative web site. (www.cebik.com/ir.html). The *NEC-4* modeling program finds no noticeable difference between insulated and bare buried radials. This relates to the capacitive coupling between the radial wire and the earth around it. Experience is what counts, and the modeling program gives the correct answer on this issue!

2.1.7.8. A radial plow

Installing radials can be quite a chore. Hyder, W7IV, (Ref 815) and Mosser, K3ZAP, (Ref 812) have described systems and tools for easy installation of radials.

2.1.7.9. Radials on the ground

Radials can also be laid on the ground (instead of being buried in the ground) in areas that are suitable. A neat way of installing radials in a lawn-covered area is to cut the grass really short at the end of the season (October), and lay the radials flat on the ground, anchored here and there with metal hooks (clothespins, doll pins, gutter nails or fencing staples). By the next spring, the grass will have covered up most of the wires, and by the end of the following year the wires will be completely covered by the grass. This will also guarantee that your radials are “as close as possible” to the surface of the ground, which is ideal from a near-field screening point of view!

2.1.7.10. Radials and salt water

The conductivity of saltwater is excellent. But you should also remember that the skin depth of saltwater is very limited, and you better keep that in mind when you install radials “in” salt water. Throwing radials in salt water and letting them sink to the bottom is like installing radials “under” a copper plate: not much use! It seems best to have many short radials dangling from the base of the antenna into the saltwater or better yet, have a few copper plates extending into the salt water to ensure a large contact surface with the saltwater.

If your antenna is exposed to the tide it seems like a good idea to have a floating device with large copper fins extending under the device in the saltwater. If the area gets dry at low tide, you should also have regular radials lying on the ground. Over saltwater, two in-line elevated radials make a very valid alternative.

2.2. Elevated Radials

With elevated VHF or UHF ground-plane antennas the three or four radials are more an electrical *counterpoise* (a 0- Ω connection point high above ground), than a ground plane. The ground is so far away that any term including the word “ground” is really not applicable. The radials of such antennas radiate in the near field (radiation from the radials only cancels in the far field), but they do not suffer near-field absorption

losses in the ground, because of their relative height above ground.

Using a small number of elevated radials does not prevent the antenna and its radials from coupling heavily to the feed line and from inducing common-mode currents onto the feed line. There will be substantial feed-line radiation unless you isolate the feed line from such common-mode currents. (See also Section 2.2.12.)

Such HF and VHF/UHF ground planes have been in use for many years. Studies that were undertaken in the past several years, however, are concerned with vertical antennas using radials at much lower heights, typically 0.01 to 0.04 λ above ground. That there is still quite a bit of controversy on this subject is no secret to insiders. It appears that a number of real-life results do confirm the current modeling results, while others do not. The jury is still out. I will try to represent both views in this book.

A. Doty, K8CFU, concluded from his experimental work (Ref 807 and 820) that a $\lambda/4$ vertical using an elevated counterpoise system can produce the same field strength as a $\lambda/4$ vertical using buried bare radials. The reasoning is that in the case of an elevated radial or counterpoise system, the return currents do not have to travel for a considerable distance through high-resistance earth, as is the case when buried radials are used. His article in April 1984 *CQ* also contains a very complete reference list of just about every publication on the subject of radials (72 references!).

Frey, W3ESU, used the same counterpoise system with his Minipoise short low-band vertical (Ref 824). He reported that connecting the elevated and insulated radial wires together at the periphery definitely yields improved performance. If a counterpoise system cannot be used, Doty recommends using insulated radials lying right on the ground, or buried as close as possible to the surface.

Quite a few years after these publications, A. Christman, R Redcliff, D. Adler, J. Breakall and A. Resnick used computer modeling to come to conclusions which are very similar to the findings brought forward after extensive field work by A. Doty. The publication in 1988 by A. Christman, K3LC (ex KB8I), has since become the standard reference work on elevated radial systems (Ref 825), work that has stirred up quite a bit of interest and further investigation.

The results from Christman's study were obtained by computer modeling using *NEC-GSD*. It is interesting to understand the different steps he followed in his analysis (all modeling was done using average ground):

1. Modeling of the $\lambda/4$ vertical with 120 buried radials (5-cm deep). This is the 1937 Brown reference. (See Section 2.1.3.)
2. The $\lambda/4$ vertical was modeled using only four radials at different radial elevations. For a modeling frequency of 3.8 MHz, Christman found that 4.5 meters was the height at which the four-radial systems equaled the 120-buried-radial systems so far as low-angle radiation performance is concerned.
3. Christman's studies also revealed that as the quality of the soil becomes worse, the elevated radial system must be raised progressively higher above the earth to reach performance on par with that of the reference 120-buried-radial vertical monopole. If the soil is highly conductive, the reverse is true.

The elevated-radial approach has become increasingly popular with low-band DXers since the publication of the above work, and it appears that elevated radials represent a viable alternative to digging and plowing, especially where the ground is unfriendly for such activities.

It is important to critically analyze the elevated-radial concept and therefore to understand the mechanism that governs the near-field absorptive losses (see Section 1.3.3) connected with elevated radials. In the case of an elevated-radial system these near-field losses can be minimized in only three ways:

1. By raising the elevated radials as high as possible (move the near field of the antenna away from the real lossy ground).
2. By installing many radials, so that these radials screen the near fields from "seeing" the underlying lossy earth.
3. By improving ground conductivity of the real ground below the raised radials.

Although the experts all agree on the mechanisms, there appears to be a good deal of controversy about the exact quantification of the losses involved (see Section 2.2.1). Incidentally, an elevated radial system does not imply that the base of the vertical must be elevated from the ground. The radials can, from ground level, slope up at a 45° angle to a support a few meters away, and from there run horizontally all the way to the end. It is a good idea to keep the radials high enough so no passersby can touch them. This is also true when radials are quite high. In an IEEE publication (Ref 7834) it was reported that significantly better field strengths were obtained with elevated radials at 10-meter height than at 5-meter height. In both cases the radials were sloping upward at a 45° angle from the insulated base of the vertical at ground level.

2.2.1. Modeling vs measuring? Elevated vs ground radials

The performance of an elevated radial system can be assessed by either computer modeling or by real-life testing and field-strength measuring. It would of course be ideal if the results from modeling and field-strength (FS) measurements match.

Al Christman used *NEC-4* to study the influence of the number of elevated radials and their height on antenna gain and antenna wave angle (Ref 7825) and came to the conclusion that if the height of the radials is at least 0.0375 λ (3 meters on 80, 6 meters on 160) there is very little gain difference between using four or up to 36 radials. He also concluded that the gain of antennas with an elevated radial system compared in gain to the same antenna with about 16 buried radials. Incidentally, the modeling also showed that for buried $\lambda/4$ radials the difference in gain between 16 radials and 120 radials is only about 0.74 dB. When raising the elevated radials to a height of 0.125 λ (20 meters on 160), the gain actually approached the gain of a vertical with 120 buried radials. The publication of these results (1988) gave a tremendous impetus in the use of elevated-radial systems.

In another study, Jack Belrose, VE2CV (Ref 7821 and 7824) also concluded that there was a good correlation between measured and computed results. In this study Belrose used a $\lambda/4$ vertical, as well as $\lambda/4$ (resonant) radials.

A good correlation between the modeled results and FS

measurements was established in several study cases. One of them was an extremely well-documented case, with thousands of FS measurements, which matched very well the figures obtained with modeling (*NEC-4*). Belrose's studies revealed that radials should be at least 0.03λ high (2.5 meters on 80 meters, 5 meters on 160 meters) to avoid excessive near-field absorption ground losses, especially so if fewer than eight radials are used. With a large number of radials (>16) the radials can be much lower.

Another well-documented case was reported in a technical paper delivered by Clarence Beverage (nephew of Harold Beverage) at the 49th NAB Broadcast Engineering Conference entitled: "New AM Broadcast Antenna Designs Having Field Validated Performance." The paper covered antenna tests done in Newburgh, NY, under special FCC authority. The antenna system consisted of a tower 120 feet in height with an insulator at the 15-foot level and six elevated radials a quarter wavelength in length spaced evenly around the tower and elevated 15 feet above the ground. The system operated on 1580 kHz at a power of 750 W. The efficiency of the antenna was determined by radial field-intensity measurements (in 12 directions) extending out to distances up to 85 km. The measured RMS efficiency was 287 mV/m (normalized) to 1 kW at 1 km, which is the same measured value as would be expected for the tower above with 120 buried radials.

In a number of other cases however, it was reported that field-strength measurements indicated a discrepancy of 3 to 6 dB with the *NEC-4* computed results. Tom Rauch, W8JI, published the following measured results:

Number of Radials	On the ground	Elevated 0.03λ
4	-5.5 dB	-4.3 dB
8	-2.7 dB	-2.4 dB
16	-1.3 dB	-0.8 dB
32	-0.8 dB	-0.7 dB
60	Reference (0 dB)	-0.2 dB

Calculations with *NEC-4* show a difference of only about 2 dB going from 4 to 60 buried radials, which is 3.5 dB less than Rauch's experiment showed. The 5 dB he found inspired the following comment: "Consider that going from a single vertical to a four square only gained me 5 dB! I got almost that just by going from four radials to 60 radials."

Eric Gustafson, N7CL, reported (on the Topband reflector) that several experiments comparing signal levels of a ground mounted $\lambda/4$ vertical with 120 radials with those produced by the same radiator with an elevated radial system (using a few radials) have been done a number of times by various researchers for various organizations ranging from the broadcast industry and universities to the military. He reported that the results of these studies always have returned the same results: The correctly sized, sufficiently dense screen is superior to four resonant radials in close proximity to earth. The quantification of the difference has varied. The largest difference Eric personally measured during research for the military was 5.8 dB, the smallest difference 3 dB. The latter one was measured over really good ground, being a dry salt-lake bed (measured conductivity approximately 20 mS during the test). It is clear that the quality of the ground plays a very important role in the exact amount of loss.

For those who would like to duplicate these tests, understand that you cannot do these tests on one and the same

vertical, switching between elevated radials to ground-mounted radials, *unless* you remove (physically) the ground-mounted radials when you use the elevated ones. If not, you have an elevated radial system *plus* a screen, effectively screening the near fields from the underlying real ground.

It seems to me that elevated-radial systems are indeed a valid alternative for buried ones, especially if buried ones are not possible or very difficult to install for whatever reason. Even the broadcast industry now uses elevated-radial systems quite extensively and successfully where local soil conditions make it impossible to use the classic 120 buried $\lambda/2$ radials. It must be said though that most of these systems use more than just a few radials. I also know of many amateur antenna systems successfully using elevated radial systems. Whether they get optimum performance or lose maybe 2 to 5 dB because of near-field absorption losses, is hard to tell. As a matter of fact, there is still the possibility of improving the ground conductivity under the elevated radial system. More on that in Section 2.2.13.

The discrepancy between measured and modeled gain figures has been recognized by a number of expert *NEC* users. All of the current modeling programs have flaws, but most are known and can be compensated for by experienced users. It seems to me that modeling of very low wires even with current versions of *NEC-4* may be affected by such a flaw.

We should also recognize that the total losses due to mechanisms in the near field can amount to much more than 5 dB. Antenna return-current losses (sometimes also called "connection" losses) can amount easily from 10 to even 40 dB over poor ground. These losses can, however, easily be mastered with elevated radials and reduced to zero. The remaining 4 or 5 dB, accountable to near-field absorption losses, are indeed somewhat more difficult to deal with using elevated radials.

2.2.2. Modeling vertical antennas with elevated radials

As mentioned before only *NEC*-based programs can model antennas with elevated radials close to ground. Roy Lewallen's *EZNEC* program (using the *NEC-2* engine) incorporates the "high-accuracy" (NEC Sommerfeld) ground model, which should be accurate for low horizontal wires down to 0.005λ high (about 2.7 feet on 160 meters).

Still, many cases have been reported indicating a difference of up to 6 dB in gain for antennas very close to ground. A similar flaw was already present in *NEC-2* and has been documented by John Belrose, VE2CV, who compared the experimentally obtained results, published by Hagn and Barker in 1970 ("Gain Measurements of a Low Dipole Antenna Over Known Soil") with the *NEC-2* predictions. At 0.01λ above ground, *NEC-2* showed 5 dB more gain than the actual measured values.

All of this goes to say that modeling software is a mathematical tool. Most modeling programs have well-known, but also sometimes little-known or barely documented limitations. Field-strength measurements are the real thing (eating is the proof of the pudding). But we should be thankful for having access to antenna-modeling programs. They have undoubtedly helped the non-professionals to gain an enormous amount of insight they would miss without these tools. It is the role of the professional, and the experts to show non-expert users how to

use them correctly, and make corrections if necessary.

2.2.3. How many elevated radials?

Through antenna modeling, K3LC (ex KB8I), calculated (for 80 meters), the $\lambda/4$ antenna gains for elevated radial heights of 5, 10, 15, 20, 25 and 30 meters, while varying the number of $\lambda/4$ radials between 4 and 36 (Ref 7825). According to these calculations, at a height of 4.5 meters (which is roughly what I have) it made less than 0.1 dB of difference between 4 and 32 radials, and this was within 0.3 dB of a buried radial system using 120 quarter-wave radials. These results were confirmed by Jack Belrose, VE2CV (Ref 7821) also through antenna modeling.

Eric Gustafson, N7CL, in a well documented e-mail addressed to the Topband reflector, explained that for a $\lambda/4$ vertical radiator, a radial system with 104 $\lambda/4$ -long radials (resulting in wire ends separated not more than 0.015λ at their tips) achieves 100% shielding effectiveness. His experimental work (radials about 5-meters high) further indicates that the screening effectiveness of a $\lambda/8$ -long radial system does not improve above 52 radials. See Fig 9-14, where we note that the experimental work by N7CL confirms the modeling results. Beyond 104 $\lambda/4$ radials there hardly is any increase in gain, and the same is true beyond 52 radials that are $\lambda/8$ long. This means that the shielding effectiveness of the $\lambda/8$ radial system with 52 radials by itself is 100%, but that some loss will be caused by near fields “spilling over” the screen at its perimeter. (In other words, the screen is dense enough, but not large enough.) Using just 26 $\lambda/4$ -long radials, you will typically lose about 0.5 dB due to near-field absorption losses in the ground.

N7CL goes on to say that a $\lambda/4$ vertical with only four elevated radials can indeed produce the same signal as a ground-mounted vertical with 120 radials $\lambda/4$ long, provided that:

1. The base of the vertical is at least $3\lambda/8$ high.
2. Or that the quality of the ground under the elevated radials has been improved so that it acts as an efficient screen, preventing the nearby field from interacting with the underlying lossy ground.

Unless such measures are effectively taken, N7CL calculated that the extra ground absorption losses can be as high as 5 or 6 dB. Loss figures of this order have been measured in a number of cases (eg, by Tom Rauch, W8JI) reported on the Topband Reflector (see Section 2.2.1).

2.2.3.1. Conclusion

According to the NEC-based modeling results, there should be no point in using more than four elevated radials. With four radials over good ground the gain of a $\lambda/4$ monopole is -0.1 dBi. Two such radials gives an average of -0.15 dBi ($+0.14$ and -0.47 dBi due to slight pattern squeezing). One elevated radial gives a gain of $+1.04$ dBi in the direction of the radial, and -2.3 dBi off its back, resulting in an integrated gain of 0.65 dBi. These optimistic figures drove many people to use four elevated radials on their verticals, convinced that they would be as loud as their neighbors using 120 buried radials. Over the years, though, the enthusiasm for elevated radials seems to have somewhat settled down, and many have returned to the old-fashioned large numbers of radials on the ground, at least where feasible.

The NEC-based modeling programs are overly optimistic when it comes to dealing with near-field absorption losses. Three or four elevated radials over a poor ground, in my humble opinion, can never be as good as 120 ground-mounted (or elevated for that matter) radials. There is simply no free lunch! If you need to use an elevated radial system, maybe it's not a bad idea after all to use 26 radials, which according to N7CL would put you within 0.5 dB of the Brown standard.

2.2.4. Radial layout

If you use a limited number of elevated radials (two, three or four), a symmetrical layout is necessary for the radiation from radials to cancel “as much as possible” in the far field. One radial is not symmetrical, but two and more are symmetrical, provided the radials are spread out evenly over 360° . When using more than four radials the exact layout as well as the exact radial length becomes of little importance about creating high-angle radiation.

2.2.4.1. Only one radial

In his original article on elevated radials (Ref 825) Christman showed the model of a $\lambda/4$ vertical using a single elevated radial. This pattern shown in Fig 9-27 is for a radial height of 0.05λ over average ground. He showed this vertical, with a single elevated radial, as having (within a minor fraction of a dB) the same gain in its favored direction as a ground-mounted vertical with 120 buried radials.

Note however that the pattern is non-symmetrical. The radiation favors the direction of the radial, resulting in a 3 to 4-dB F/B over average ground. Modeling the same vertical over very good ground results in much less directivity, and over saltwater the antenna becomes perfectly omnidirectional.

I expect that it is sufficient to install radials on the ground under the antenna to improve the properties of the ground in the near field of the antenna to a point where the directivity, due to the single radial, is reduced to less than 1 dB. The slight directivity can be used to advantage in a setup where one would have a vertical with four radials, which are then connected one at a time to the vertical antenna. Another application (Ref 7824) is where the vertical is part of a fixed array, and where you make use of the initial directivity of each element to provide some added directivity (see Fig 9-28).

The single radial does not only create some horizontal

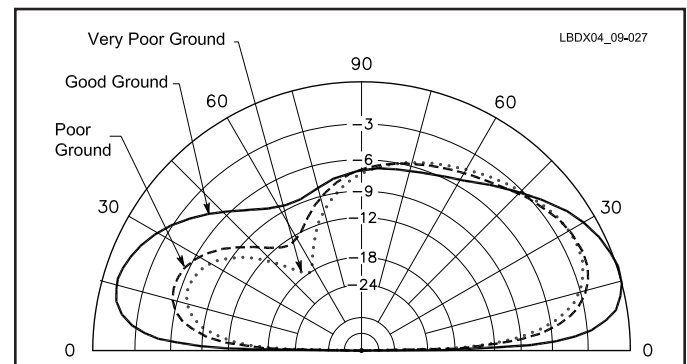

Fig 9-27—Vertical radiation pattern of a quarter-wave vertical with one horizontal $\lambda/4$ radial at a height of 0.05λ over different types of ground.

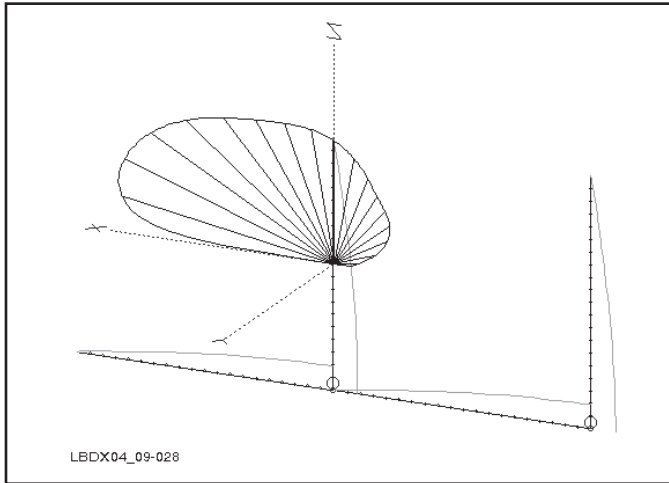

Fig 9-28—Two $\lambda/4$ verticals are used in an end-fire configuration (see Chapter 10), producing a cardioid pattern. By placing the single radial in the forward direction of the array, some additional gain can be achieved. This technique makes it impossible to switch directions.

directivity, it also introduces some high-angle radiation, caused by the radiation from the single radial. If two or more radials are used, they can be set up in such a way that the horizontal radiation of these radials is effectively canceled. Notice from Fig 9-27 that most of the high-angle pattern energy is at or near 90° .

If you are looking for maximum low-angle radiation (which is normally the case for DXing), using only one radial is not the best choice, especially if the antenna is going to be used for reception as well. In a contest-station environment, however, creating some high-angle radiation, to give some “presence” on the band with locals can be desirable. If separate directive low-angle receiving antennas (eg, Beverages) are used, using a single radial on a vertical may well be a logical choice. I am using a single 5-meter high elevated radial on my 80-meter Four Square (radials pointing out of the square). At the same time I have a decent shielding effect on the real ground because of the more than 200 radials for the 160-meter vertical, which supports the 80-meter wire Four Square (see Chapter 11).

A vertical with a single radial can also be a logical choice for a DXpedition antenna (over saltwater or over a ground screen) for two reasons:

1. Ease of adjusting resonance from the CW to the phone end of the band, by just lengthening the radial.
2. Extra gain by putting the radial in the wanted direction (toward areas of the world with high amateur population density).

2.2.5. How high should the radials be?

The NEC-modeling results, published by Christman, K3LC (ex KB8I), indicate that radials above a height of approximately 0.03λ achieve gains within typically 0.2 dB of what can be achieved with 64 buried radials. In other words, there is no point in raising the radials any higher than 6 meters on 160 or 3 meters on 80 meters.

Measurements done by Eric Gustafson, N7CL, however,

tell us a totally different and very logical story. To prevent the near fields created by the radial currents from causing absorption losses in the underlying ground, the radials must be high enough so that the near fields do not touch ground. With up to six radials, this is between $\lambda/8$ and $\lambda/4$. Below $\lambda/8$ the losses are very considerable (if no other screen is available). For amateur purposes with four radials, a minimum height of $\lambda/4$ would be a reasonable limit to use. The minimum height decreases as the density of the radial screen is increased. With a density of about 100 quarter-wave long radials (in which case the distance between the tips of the radials is 0.015λ) the radial plane can be lowered all the way onto the ground without incurring significant near-field absorption loss. This is shown in Fig 9-15, where beyond 100 radials there is little to gain. At a height of about 0.03λ , 26 radials will result in an absorption loss of not more than 0.5 dB, according to N7CL.

Conclusion: If you want to play it extra safe, and if you have the tower height, get the radials up as high as possible and add a few more. Having more radials will make their exact length much less critical as well. Another solution that I have used is to put radials and chicken-wire strips on the ground to achieve an “on-the-ground screen” in addition to your small number of elevated radials (see Section 2.2.13).

It all is very logical. Get away from the lossy ground by raising the radials higher above the ground or hide the lossy ground with a dense screen using many radials.

2.2.6. Why quarter-wave radials in an elevated radial system?

In modeling it is quite easy to create perfectly resonant quarter-wave radials. Why do we want them to be exactly $\lambda/4$ long? Let’s examine this issue. What we really want is the vertical plus the radials to be resonant, not because this would make the antenna radiate better, but only because that makes it easier to feed the antenna.

Dick Weber, K5IU, found through a lot of measuring and testing of real-life verticals with elevated radials that using $\lambda/4$ -long elevated radials has a certain disadvantage. In his models he used four radials (one per 90° of azimuth) because he wanted the radiation from these radials to be completely canceled: no pattern distortion and no high-angle horizontally polarized radiation. He found out though that this is very

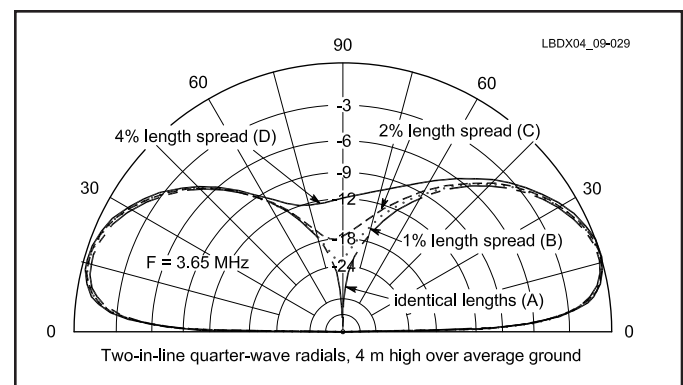

Fig 9-29—Vertical radiation patterns (over good ground) for a $\lambda/4$ long 80-meter vertical, with two in-line radials 4 meters high, for various radial lengths around $\lambda/4$. See text for details.

difficult, if not impossible, to achieve in the real world. Of course, $\lambda/4$ radials works fine on a computer model, since you can define four radials that have exactly the same electrical length. But this is not always the case in the real world. One radial will always be, perhaps by only a minute amount, electrically longer or shorter than another one. And therein lies the problem. We want these four radials all to carry exactly the same current, in order for the radiation to balance out.

The real question is how important are equal currents in the radials? I modeled several cases of intentional radial current imbalance. **Fig 9-29** shows the vertical radiation pattern of a $\lambda/4$ -vertical ($F = 3.65$ MHz), with two elevated radials, 4 meters high. Pattern A is for two radials showing no reactance (both perfectly 90° , which can never be achieved in real life). For pattern B, I have intentionally shortened one radial about 20 cm (approximately 1% of the radial length). This introduced a reactance of $-j 8 \Omega$ for this radial. One radial now carried 62% of the antenna current, the other the remaining 38%. Over good ground this imbalance causes the horizontal pattern to be skewed about 0.6 dB (an inconsequential amount), but we see a fill-in of the high-angle rejection (around 90° elevation) that we would expect to have when the currents are really equal. Pattern C is for a case where one radial is 20 cm too short, and the other one 20 cm too long (reactance $-j 8 \Omega$ and $+j 8 \Omega$). In this case the relative current distribution was very similar as in the first case (63% and 36%). The horizontal pattern skewing was the same as well. Pattern D is for a rather extreme case where radials differ 80 cm in length ($+j 16 \Omega$ and $-j 16 \Omega$). Current imbalance has now increased to 76% versus 24%.

I did a similar computer analysis for a vertical using four elevated radials. In this case, I did the analysis over three different types of ground: good ground, very good ground and seawater (ideal case).

Fig 9-30 shows the results of these models. Case A is for equal currents in the four radials (theoretical case); case B is for radials showing reactances of $+j 8 \Omega$, 0Ω , $-j 8 \Omega$, and $+j 10 \Omega$. The relative current distribution in the four radials was: 51%, 39%, 5% and 5%, which are values very similar to what has been measured experimentally by K5IU. Pattern C shows a rather extreme imbalance with radial reactances of $-j 16 \Omega$, 0Ω , $+j 16 \Omega$ and $+j 8 \Omega$ (a total length spread of 4% of the nominal radial length). In this case the relative currents in the radials are 54%, 28%, 8% and 10%. Plot 1 is for the antenna over good ground, Plot 2 over very good ground, and Plot 3 over sea water.

Note that the pattern deformation depends to a very high degree on the quality of the ground under the antenna! Over seawater the current imbalances practically cause no pattern deformation at all. The horizontal pattern squeeze is at maximum 1.6 dB over good ground, and 0.6 dB over very good ground, computed at the main elevation angle.

From this it appears that in addition to using a few (typically less than 10) elevated radials, it is a good idea to improve the ground conductivity right under the radials by installing a ground screen using radials there as well. This is for two different reasons: To form a screen hiding the lossy ground from the antenna, and to reduce the effect of high-angle radiation from the radials.

You should understand that if you have enough elevated

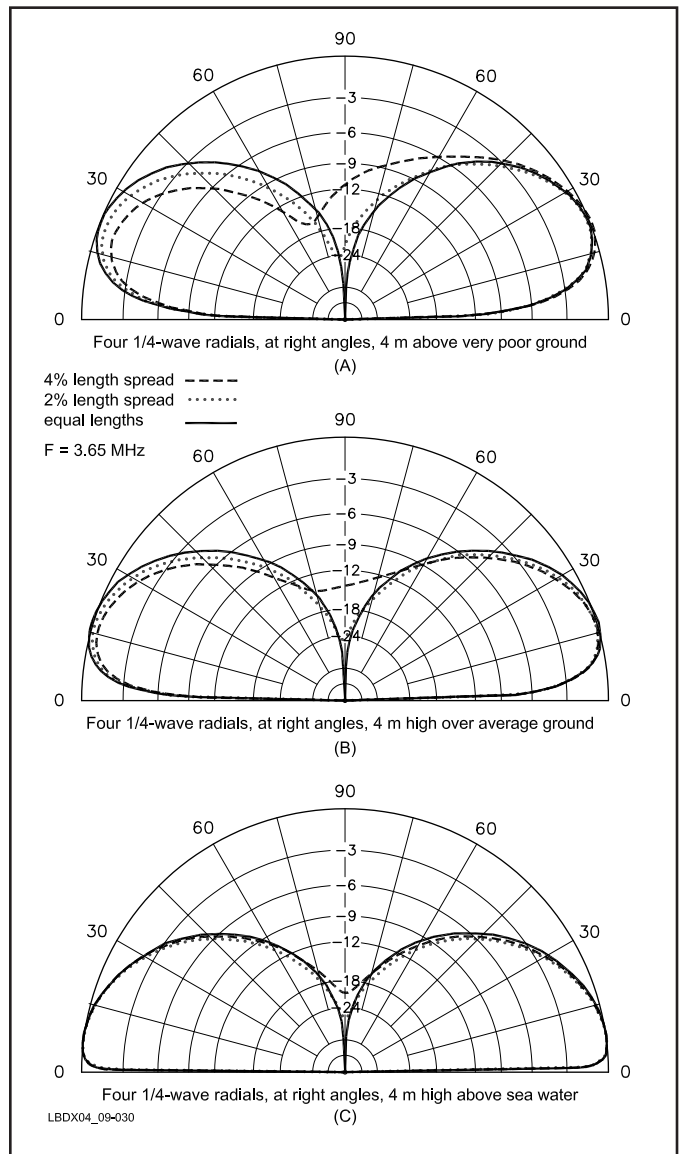

Fig 9-30—Vertical radiation patterns of an 80-meter $\lambda/4$ vertical with four elevated radials (4 meters high) over various types of ground. Patterns are for: (A) average ground, (B) very good ground and (C) saltwater. See text for details.

radials any variation in the exact electrical length will *not* result in high-angle radiation or pattern squeezing. With 16 radials, length variations of $\pm 1.5\%$, and angular variations of $\pm 5^\circ$ (not evenly spaced in azimuth), the effect is of no consequence, resulting in horizontally polarized radiation components down > 40 dB). The radials now form a screen that no longer shows resonance, just like the case with radials on the ground.

You also need a large number of elevated radials to avoid excessive near-field losses. You can kill two birds with one stone with a raised radial system using at least 16 radials.

Dick Weber, K5IU, measured many real-life installations with either two, three or four elevated radials, and it was not uncommon to find one radial taking 80% of the antenna current, one radial 20% and the other two almost zero! The recorded variations in radial currents were used to calculate

the patterns shown in Fig 9-30.

The question now is whether or not you can live with the high-angle fill in, (mostly around the 90° elevation angle) and slight pattern-squeeze (typically not more than 1 dB).

If you want maximum low-angle radiation, and if you don't want to lose a fraction of a dB, and if you don't want to put up a few more radials, then equal-radial currents may be for you. Or maybe you would like some high-angle radiation? Maybe you are not using your vertical or vertical array for reception, and you want some high-angle radiation? If you are a contest operator, this is a good idea (you want some local presence as well). In that case, don't bother with equal radial currents, maybe just one radial is the answer for you, as I did.

However, even a small number of radials that are laid out perfectly symmetrically and that carry identical currents are no guarantee of 100% cancellation of the horizontal high-angle radiation in the far field. Slight differences in ground quality under the radial wires (or environment, trees, bushes, buildings) can result in different near-field absorption losses under radials that would otherwise carry identical RF currents. The result will be incomplete cancellation of their radiated fields in the far field. Measuring radial currents does not, indeed, tell you the full story!

It is interesting though to understand why slight differences in radial lengths can cause such large differences in radial current. A $\lambda/4$ radial is equivalent to an open-circuited $\lambda/4$ transmission line that uses the ground as the second conductor. This acts like a dead short at its resonant frequency. When this short is connected in parallel with another $\lambda/4$ radial, it's like connecting a short circuit across another short circuit, and then expecting that both shorts will take exactly the same current.

We have similar situations in electronics when we parallel devices such as power transistors in power supplies, or when we parallel stubs to reject harmonics on the output of a transmitter. If one stub gives us 30 dB of attenuation, connecting a second one right across the first one will increase the attenuation by 3 dB at the most. If we take special measures ($\lambda/4$ lines at the harmonic frequency) between the two stubs, then we get greater attenuation (almost double that of the single stub, an additional 6 dB). **Fig 9-31** shows the equivalent schematic of the situation using $\lambda/4$ radials.

2.2.6.1. Conclusions

1. For elevated radial systems using two, three or four (resonant) $\lambda/4$ radials, slight differences in electrical length cause radial current imbalances, resulting in some high-angle radiation as well as some pattern squeezing, especially over less than very good ground. However, even perfectly balanced currents are not a 100% guarantee for zero high-angle radiation (due to unequal near-field ground losses under different radials).
2. Starting with eight radials (or more) the influence of unequal radial current on the generation of high-angle radiation is almost nonexistent. If you are greatly concerned about a little high-angle radiation, you should simply increase the number of elevated radials to eight.
3. Adding a good ground screen under the antenna totally annihilates the effects of unequal radial currents, and in addition it will raise the gain of the antenna by up to 5 dB!
4. By the way, you need not to concern about any of these

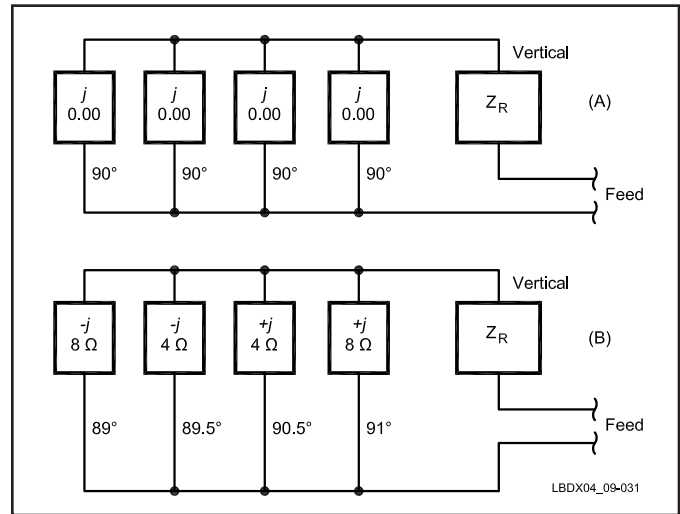

Fig 9-31—At A the ideal (not of this world) case where all four radials are exactly 90° long. They all are a perfect short and exhibit zero reactance. At B the real life situation, where it now is clear that in this circuit, where the current divides into four branches, these currents are now very unequal.

issues with a classic in (or on) the ground radial system using 60 radials.

2.2.7. Making quarter-wave radials of equal length

Despite all of that, it's nice to know how you can make $\lambda/4$ radials of identical electrical length! In the past, one of the standard methods of making resonant radials, was to connect them as a (low) dipole and prune them to resonance. It is evident that resonance does not mean that both halves of the dipole have the same electrical length, even if both halves are the same physical length. One half could exhibit $+j 20 \Omega$ reactance, while the other half could exhibit a so-called conjugate reactance, $-j 20 \Omega$. At the same time the dipole would be perfectly resonant.

Nevertheless, there is a more valid method of constructing radials that have the same electrical length. Whether these are perfect $\lambda/4$ radials is not so important, we can always tune out any remaining reactance with a small series coil or a capacitor (if too long). This method is as follows:

- Model the length of the vertical to be $\lambda/4$ at the design frequency.
- Put up an elevated vertical of the computed length.
- Use one of the charts in **Fig 9-32** to determine the theoretical radial length. Note that the length is very dependent on radial height.
- Connect one radial.
- Trim the radial to bring the vertical to resonance.
- Disconnect the radial.
- Put up the second radial in line with number one.
- Trim this second radial for resonance.
- If you use four radials, do the same with the remaining two radials.

Then connect all radials to the vertical and check its resonant frequency. It is likely that the vertical will no longer be resonant at the design frequency. Is it necessary to have the

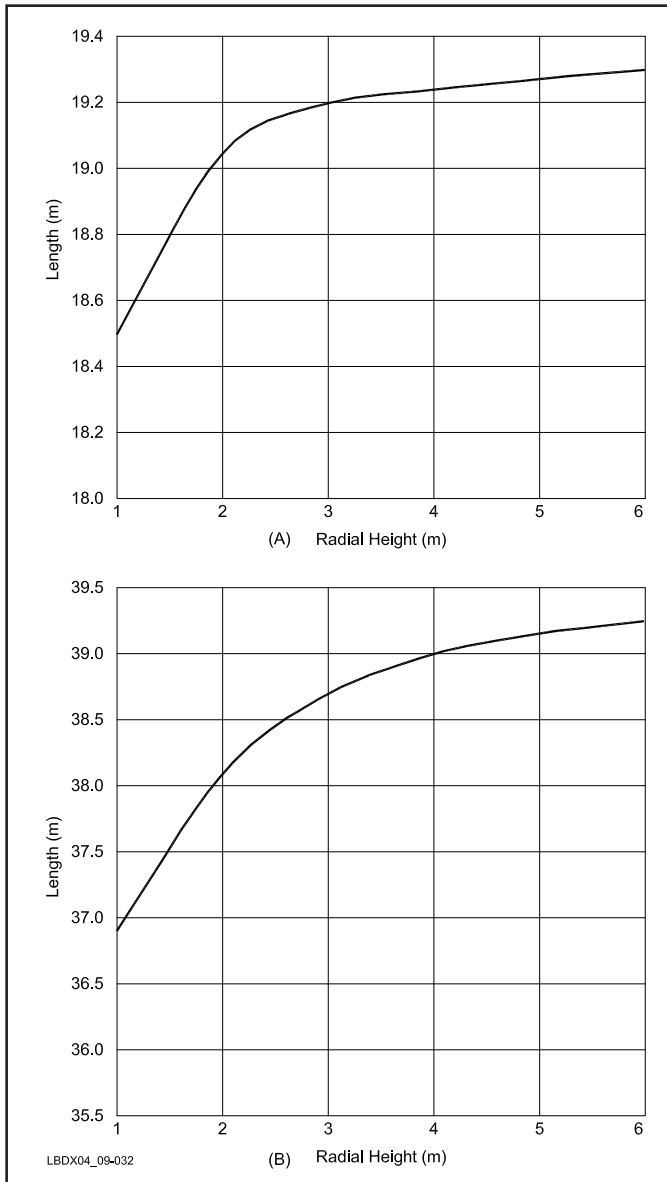

Fig 9-32—Length of a $\lambda/4$ radial as a function of the height above ground. For 80 meters at A; for 160 meters at B.

vertical at exactly $\lambda/4$? No, but if you want, here are two procedures to make the antenna plus radials perfectly resonant on your design frequency:

2.2.7.1. First method

This requires changing the length of the vertical to bring the system to resonance. Do not change any radial length, but change the length of the vertical to achieve resonance at the desired frequency.

2.2.7.2. Second method

Change all radials in length by exactly the same amount (all together, not one at a time) until you establish resonance. Neither of these two methods guarantees that both the radial system and the vertical are exactly a quarter wavelength, they only guarantee that both connected together are resonant.

Again, it is totally irrelevant whether both are 90° long or not. It is not unusual that radials of different physical length result in identical electrical lengths. This is mainly due to the variation of ground conductivity, which can vary to a wide degree over small distances. Other causes are coupling to nearby conductors.

On the other hand, radials of exactly the same electrical length are still no guarantee for identical radial current because of near-field losses being different under different radials (see Section 2.2.6).

2.2.8. The K5IU solution to unequal radial currents

D. Weber, K5IU, inspired by Moxon (Ref 693, pages 154-157 in the First Edition, pages 182-185 in the Second Edition, and Ref 7833) installed radials shorter than $\lambda/4$ and tuned the radial assembly to resonance with a coil. It appears that slight changes in electrical length of these “short” radials have little influence on the current in the various radials (Ref 7822 and 7823).

Weber’s modeling studies showed that radial lengths between 45° and 60° and between 115° and 135° resulted in minimum creation of high-angle radiation from unequal electrical radial lengths. When using radials longer than 90° the system can be tuned to resonance using a series capacitor, which is easier to adjust than a coil and which also has intrinsically less losses (see Fig 9-33). The purist may even use a motor-driven (vacuum) capacitor, which could be used to obtain an almost perfect SWR anywhere in the band.

I would suggest, however, not to shorten the radials to less than approximately 60° - 70° if not really necessary. It is clear that we cannot indefinitely shorten radials, and expect to get the same results. If that were true we should all use two in-line loaded mobile whips on our 160-meter tower as a radial (current collecting) system. T. Rauch, W8JI, put it very clearly on the Topband reflector: “*The last thing in the world*

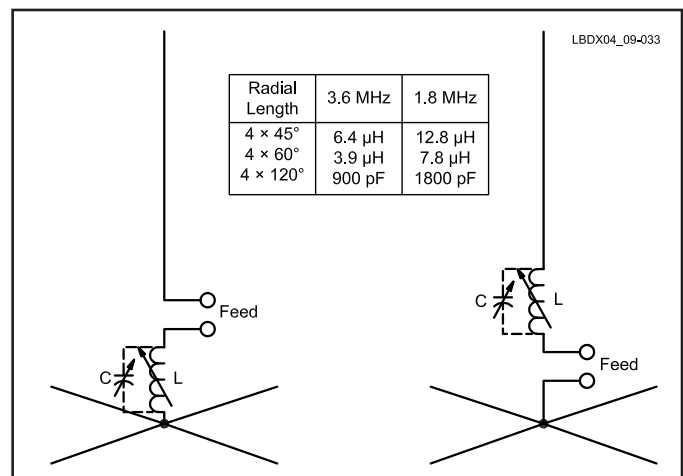

Fig 9-33—When radials shorter than 90° are used, the system must be tuned to resonance using a coil. With radials longer than 90° the tuning element is a capacitor. Typical values for the tuning elements are also shown. The feed line can be connected in two different ways: Between the tuning element and the radiator or between the tuning element and the radials. The result is exactly the same. In both cases, a coaxial feed line connected to the feed point *must* be equipped with a current balun.

I'd want to do is concentrate the current and voltage in smaller areas. Resonant radials, or especially shortened resonant radials, concentrate the electric and magnetic fields in a small area. This increases loss greatly. The ideal case is where the ground system carries current that evenly, and slowly, disperses over a large physical area, and has no large concentrated electric fields from high voltage." This is clearly another plea for the classic, multi-radial ground system. I did some modeling myself using EZNEC and found that:

- The fewer the radials, the greater the current imbalance due to length variations.
- The worse the ground quality the greater the impact of current imbalance on the radiation pattern.
- Starting with 16 radials, the effect of current imbalance is totally gone, even with 90° radials.

2.2.8.1. Conclusion

You can solve the problem of high-angle radiation by using a larger number of radials (for example, 16) or by improving the ground quality under the radials by installing a ground screen, at the same time yielding less near-field ground-absorption losses!

2.2.9. Should the vertical be a quarter-wave?

From a radiation point of view, neither a vertical with a buried-radial ground system nor one with an elevated-radial system necessarily must be resonant. We usually make these resonant because it makes feeding the antenna easier.

A buried ground-radial system is a non-resonant, low-impedance system. Over such a ground system the vertical is usually made resonant (90° long electrically), to have a non-reactive feed-point resistance. Verticals somewhat longer than $\lambda/4$ (usually about $3\lambda/8$) can be tuned to resonance using a series capacitor. Although most $3\lambda/8$ verticals use ground-mounted radials, the same can be done with a $3\lambda/8$ vertical

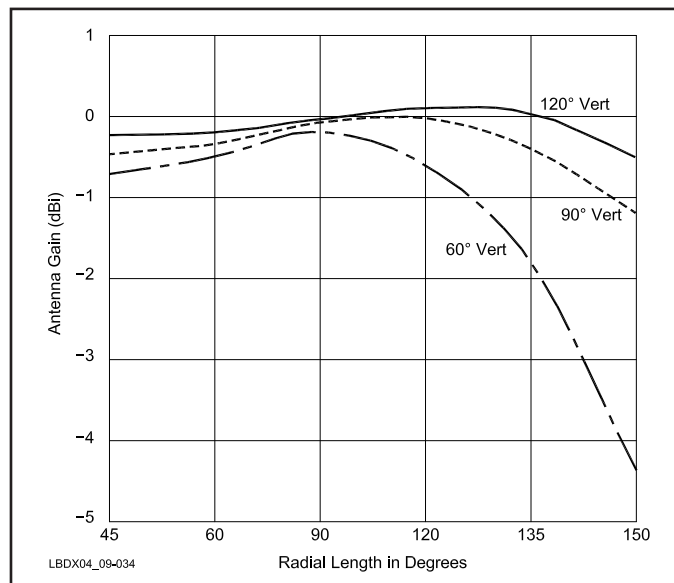

Fig 9-34—Gain as a function of radial length for verticals measuring 60°, 90° and 120° over average ground (all using four elevated radials about 0.012- λ high) as calculated by K5IU.

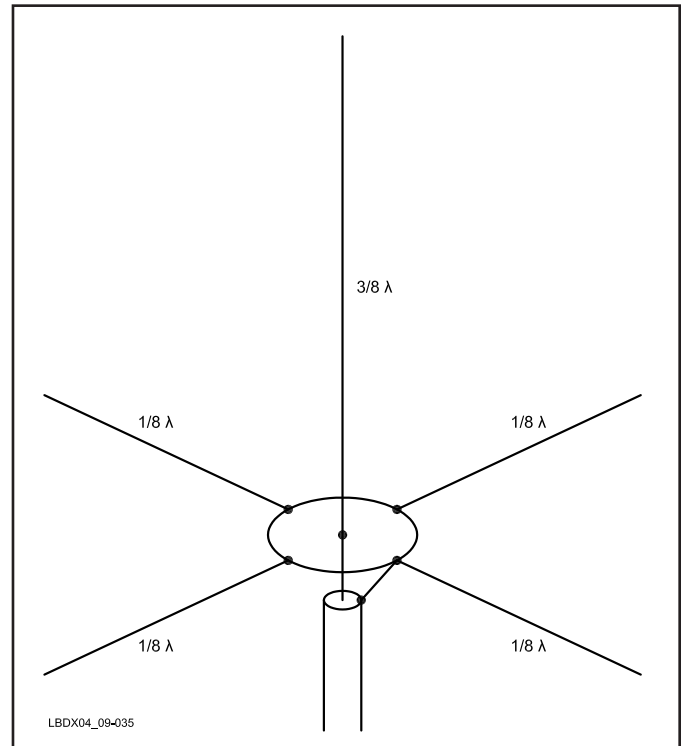

Fig 9-35—A $3\lambda/8$ vertical used in conjunction with 45° long radials does not require any series coil to tune the antenna, hence losses are minimized.

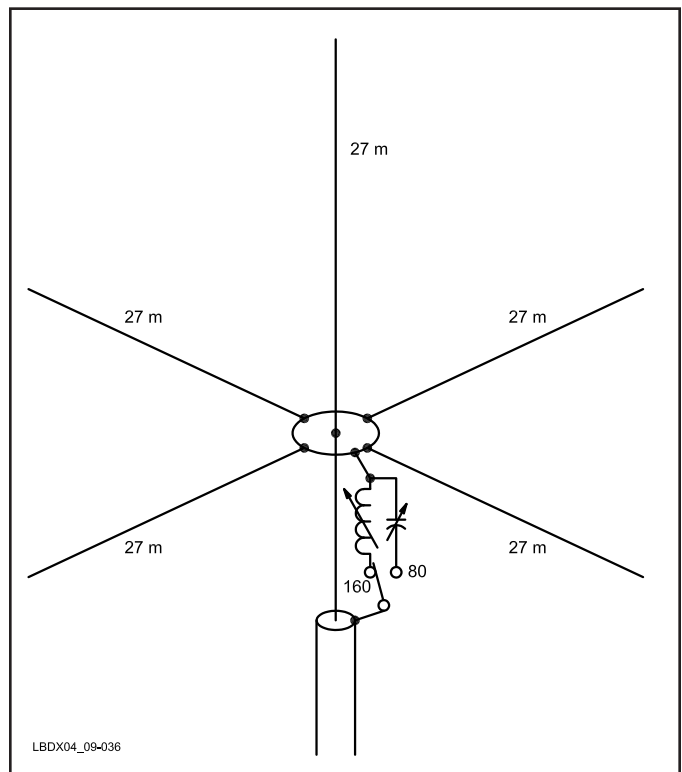

Fig 9-36—A 27-meter long vertical with 27-meter long radial makes an excellent antenna for both 80 and 160. Band switching only requires the switching of the loading element from a coil (160 meters) to a capacitor (80 meters).

using elevated radials.

Remember that with a small number of radials (up to about 10), the length of each of these radials is critical and the radial system has a resonant character that is more pronounced as the number of radials is reduced. This means that if you use only a few radials, you can adjust their length to change the resonant frequency of the vertical. With a large enough number of radials the system becomes non-resonant (like a ground screen) and changing radial lengths has no influence on the resonant frequency of the antenna system. See **Fig 9-34**.

Using this concept we can envisage a $3\lambda/8$ vertical to be used in conjunction with, say, $\lambda/8$ long radials. A 3.75-MHz vertical designed according to these principles is shown in **Fig 9-35**. The combination of a $3\lambda/8$ -long radiator and $\lambda/8$ -long radials does not require a coil to tune the antenna. The radiator length shown for a wire element whose diameter is 2 mm is 26.9 meters long. With four 10-meter long radials, the feed impedance is exactly 52Ω , an excellent match for $50\text{-}\Omega$ feed line.

The same vertical can be turned into an 80/160-meter vertical using 27-meter long radials (60° on 160 meters and 120° on 80 meters) as shown in **Fig 9-36**. The total system length on 160 meters is $60^\circ + 60^\circ = 120^\circ$, which is less than 180° ($\lambda/2$); hence a coil is required to resonate the antenna. On 80 meters, the total length is $120^\circ + 120^\circ = 240^\circ$, which is longer than $\lambda/2$; hence, a capacitor is required.

2.2.10. Elevated radials on grounded towers

2.2.10.1. The N4KG antenna

T. Russell, N4KG, an eminent low-band DXer, described a method of shunt feeding grounded towers in conjunction with elevated radials (Ref 7813 and 7832). His tower uses a TH7DX triband Yagi as top loading (see **Fig 9-37**). It is important to find the attachment point of the radials on the tower whereby the part of the tower above the feed point becomes resonant in conjunction with the radials. Russell installed 10 $\lambda/4$ radials and moved the ring to which these radials were attached up and down the tower until he found the system in resonance. This point was 4.5 meters above ground.

John Belrose, VE2CV, analyzed N4KG's setup using *NEC-4* (Ref 7821). He simulated the connection to earth of the tower (at the base) by using a 5-meter long ground rod (a decent dc ground). It is obvious that RF current is flowing through the tower section below the feed point. This current causes the gain of the antenna to be somewhat lower than that of a $\lambda/4$ base-fed tower. Belrose calculated the difference as 0.8 dB.

A typical configuration like the one described by N4KG will yield a 2:1 SWR bandwidth of 100 to 150 kHz. There are several approaches to broadband the design. Sam Leslie, W4PK, designed a system where he uses two sets of two radials, installed at right angles. One set is cut to resonate the system at the low end of 80 meters (CW band) and the other at the phone end. The SWR curve has two dips now, one on 3.5 and the other on 3.8 MHz.

Another approach is to design the antenna for resonance on 80-meter CW, and tune it to resonance in the SSB portion by inserting a capacitor between the feed line and the

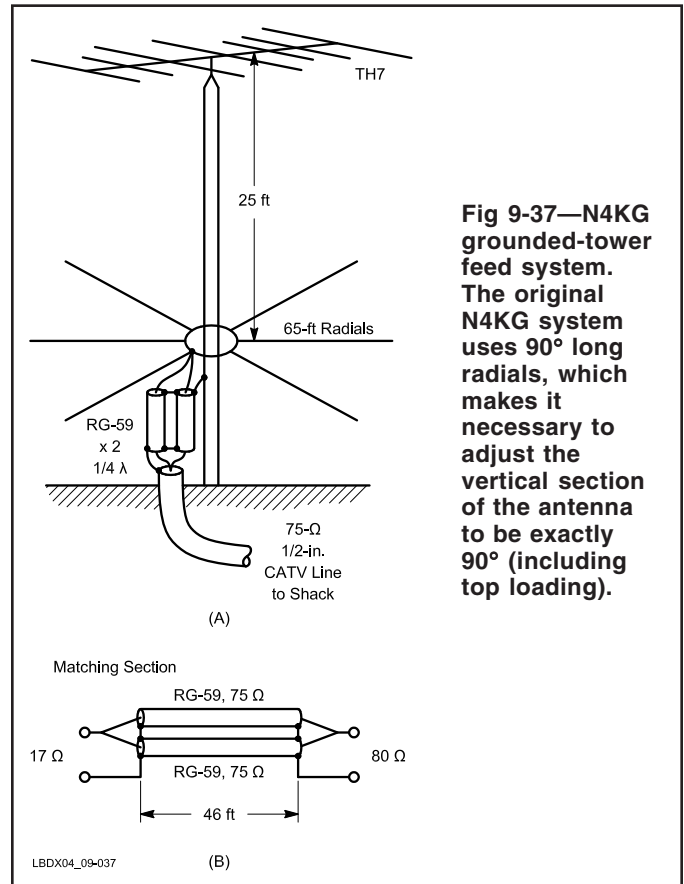

Fig 9-37—N4KG grounded-tower feed system. The original N4KG system uses 90° long radials, which makes it necessary to adjust the vertical section of the antenna to be exactly 90° (including top loading).

radials or the vertical conductor (tuning out the inductive reactance on 3.8 MHz).

2.2.10.2. Decoupling the tower base from the real ground

It is possible to minimize the loss by decoupling the base of the vertical from ground. Methods of doing so were described by Moxon (Ref 693 and 7833). **Fig 9-38** shows the layout of a so-called *linear trap* that turns the tower section between the feed point and ground into a high impedance, effectively isolating the antenna feed point from the dc-ground rod. The trap is constructed as follows:

- Connect a shunt arm about 50 cm in length to the tower, just below the antenna feed point.
- Connect a drop wire, parallel with the tower, from the end of the arm to ground level and connect it back to the base of the tower. This forms a loop.
- Insert a variable capacitor in the drop wire (wherever convenient).
- Excite the vertical antenna (above the linear stub) with some RF.
- Use an RF current probe (such as a Palomar type PCM1) and tune the capacitor for maximum current in the drop wire.
- You're done!

The loop tower + drop wire + capacitor now form a parallel-resonant circuit at the operating frequency. This ensures that no RF currents can flow through the bottom tower section to the lossy ground.

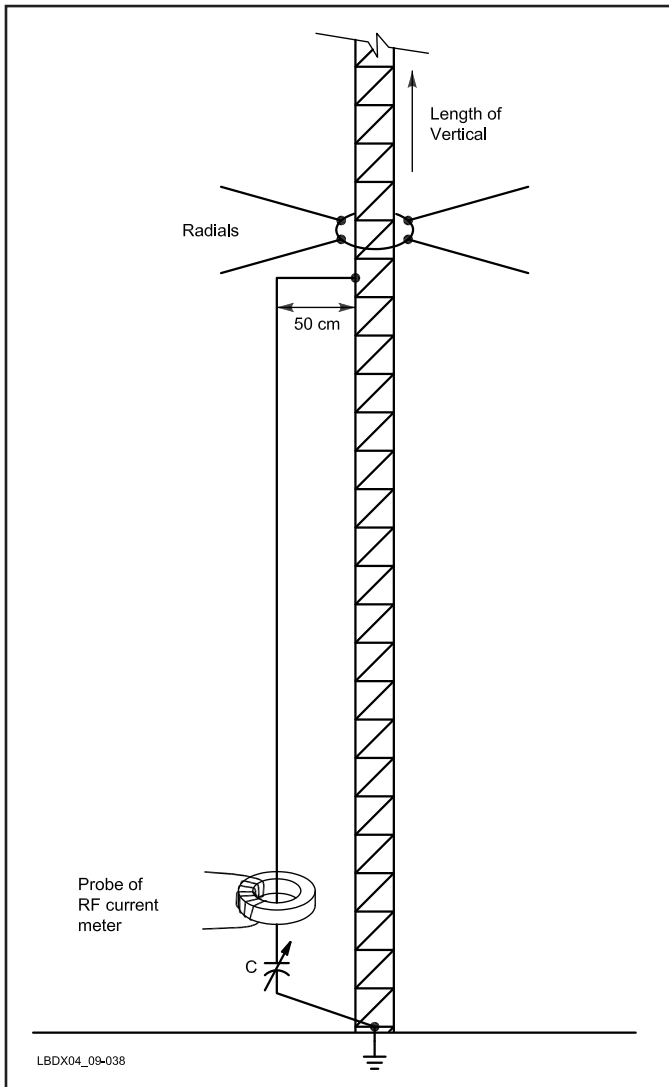

Fig 9-38—The grounded-tower section below the antenna feed point can be made a resonant linear trap, which inserts a high impedance between the antenna feed point and the bottom of the tower. Tune capacitor for maximum current in the loop.

2.2.10.3. Summing up

Using grounded towers with an elevated radial system can readily be done. The principles are simple:

- The vertical (top loaded or not) together with the radial system must be resonant
- Use the largest number of radials you can accommodate to obtain a ground-shielding effect.
- Provisions must be taken for minimum RF return current to flow in the ground. The section of the tower below the feed point should thus be decoupled.

2.2.11. The N4KG reverse-feed system

Russell feeds his design in Fig 9-37 in an unconventional way, with the center of the coax going to the radials, and the outer shield going to the vertical part. He claims this prevents arcing through from the braid of the coax to the tower. Tom coils up his parallel 75-Ω coax inside the tower leg, and that

forms an RF choke. I would strongly suggest *not* to tape the coax (or the coiled coax) to the leg of the tower, especially when a linear trap is installed, since there may be a rather steep RF voltage gradient on that leg. I would keep the coax a few inches from all metal, and route it in the center *inside* the tower. In addition to the coiled coax I would certainly use a current balun made of a stack of ferrites, installed beyond the $\lambda/4$ transformer toward the transmitter. Whether or not the braid or the inner conductor goes to radials is irrelevant if a good current balun is used.

2.2.12. Practical design guidelines, elevated radials with grounded towers

If you have a grounded tower and you want to use it with an elevated radial system with four radials, you can proceed as follows:

1. Define the height where you want to have the radials. You might start at 6 meters. Convert to degrees ($360^\circ = 300/F_{\text{MHz}}$) and 6 meters = 13° on 160 meters. If you have enough physical tower height, put the radials as high as possible, since this helps reduce the near-field absorption losses from the ground.
2. Define the electrical length of the tower. Let us assume you have a 30-meter tower with a 5-element 20-meter Yagi on top. From Fig 9-84 we learn that this tower has an electrical length of about 123° .
3. The electrical length of the tower above the radial attaching point is $123^\circ - 13^\circ = 110^\circ$.
4. Cut four radials to identical electrical length as explained in Section 2.2.7.
5. Whether or not you will require a coil or a capacitor to tune the system to resonance depends on the *total* length of the antenna vertical part *plus* radials. If the length is greater than 180° , a capacitor will be required. An inductor will be required if the total length is less than 180° . Assume for this example that you use 120° long radials, so that the total antenna length is $110^\circ + 120^\circ = 230^\circ$. A series capacitor will be required to tune the system to resonance.
6. Measure the impedance at resonance using an antenna analyzer. If necessary use an unun or a quarter-wave transformer (or other suitable impedance matching system) to get an acceptable match to your feed-line impedance.
7. Install the linear trap on the tower section under the feed point and tune the loop to resonance by adjusting the loop variable capacitor (see procedure above).
8. You are all done!

Fig 9-39 shows the final configuration of the antenna we designed above. It is obvious that the tower must use non-conducting guys, or if steel guy wires are used they must be broken up in short lengths so that they do not interfere with the vertical antenna.

Finally, here's some perspective. Maybe it's not such a good idea after all to have elevated radials on your grounded tower because it makes things more complicated. You need a linear trap to decouple the bottom of the tower from the real ground and you need to have radials above ground. Maybe 10 or 20 radials on the ground would do the job just as well. The real reason I can see for elevated radials on a grounded tower is when that tower is electrically too long (for example, $> 140^\circ$ rather than 90°). For this case you can shorten the tower

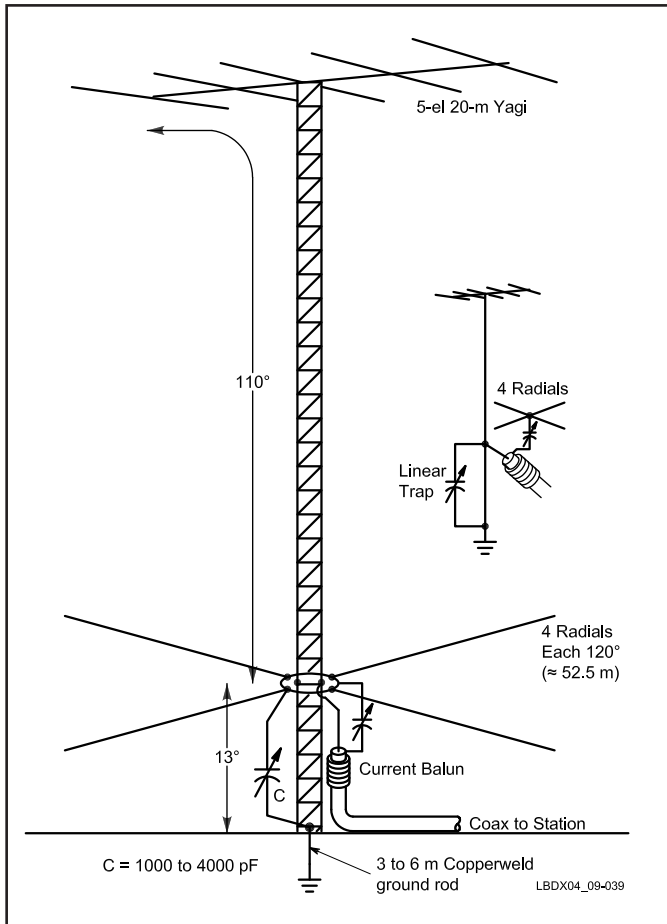

Fig 9-39—Design example of a grounded vertical using an elevated-radial system (see text for details).

electrically using an elevated radial system. Watch out, however, if the radial system is fairly high above ground, because the vertical radiation pattern becomes different from that of a ground-mounted vertical.

2.2.13. Elevated radials combined with radial screen on the ground

All publications I have seen so far on the subject of elevated radials use either one of the modeling standard grounds (Average, Good, etc—see Table 5-2 in Chapter 5), or they have been done over whatever type of ground that happened to be there where the tests were run.

The modeling I have done suggests that improving the ground right under the vertical and its elevated radials can increase the system gain, especially if only one to four elevated radials are used (see Section 2.2.3 and Fig 9-27). For the case of a single radial or when using $\approx 90^\circ$ long radials, improving the ground quality right under the antenna can greatly reduce horizontally polarized high-angle radiation and can increase the antenna gain. This can be accomplished by putting down radials or ground screens on the lossy ground.

It is important to understand that these on-the-ground radials (or screen in whatever shape) should *not* be galvanically connected in any way to the elevated radials in any way. They should be connected to nothing, since we don't want any antenna return currents to flow in the ground.

If you have the space, and a potential 4 to 5 dB is worth the expense and effort to you, by all means provide a ground screen. In the case you do *not* want to use the screen for antenna current collecting, the screen does not have to have the shape of radial wires. A net of copper wires, with a mesh density measuring less than approx. 0.015λ (1 meter on 80; 2 meters on 160), or even 0.03λ if you are willing to sacrifice maybe 0.5 dB, is all that is needed to provide an effective near-field screen. Make sure that the crossing copper wires make good and permanent electrical connections at their joints (see Section 2.1.7).

If you use but one elevated radial, you may want to increase the ground net density in the area under that radial. In principle the screen should have a radius of $\lambda/4$ (for a $\lambda/4$ vertical), but a screen measuring only $\lambda/8$ in radius will typically be about 0.3 dB down from a $\lambda/4$ radius ground screen. Of course the saltwater environment shown in Fig 9-40 makes for a virtually “perfect” ground screen, even though only two elevated radials were used!

For over five years now, I have very successfully used $\lambda/4$ verticals in my Four-Square array, each using a single $\lambda/4$ radial at about 5-meters in height. Judging an antenna's performance by the DX worked with it certainly makes no sense. But judging the same antenna's performance by the repetitive results obtained in world-class DX contests, may be



Fig 9-40—The Titanex V160E antenna on the beach at 3B7RF (St Brandon Island). Note the two elevated radials about 2 meters above salt water. The combination of one or two elevated radials with a perfect ground underneath is hard to beat.

a good indication indeed about whether the antenna works well or not. Operated over ground that is literally swamped with copper wire, I have never scored less than a first or second place for Europe in the ARRL International DX Contest (single-band 80 meters), both CW and SSB and that is in 18 contests since 1994. In addition, I set a new European record with that antenna. Taking into account that my QTH is certainly not the best for working Ws (Normandy or the UK West Coast are better places), this means that such a vertical—even with a single elevated radial—can be a top performer.

2.2.14. Avoiding return currents through the soil

Fig 9-41 shows the vertical antenna return paths for different radial configurations. Fig 9-41A shows the case where a simple ground rod is used, where the antenna return currents have to travel entirely through the lossy soil. This reduces the radiation efficiency of the vertical to a very high degree, because of the I^2R ground losses. Burying radials in the ground can greatly reduce the losses as the return currents can now travel, to a great extent (depending on the number and the length of the radials) through the low-loss radial conductors in the ground, as Fig 9-41B shows.

Fig 9-41C shows two radials elevated above ground. There are now two current return paths: the lossless path

through the two radials and a lossy path through the soil.

We can minimize the currents in this parasitic path by:

- Raising the radials high above ground: Once the radials are a few meters above ground, the capacity to the lossy soil is rather small.
- Using fewer radials: More radials means more capacitance, thus more current in the ground and hence more ground losses.
- Using more radials: More radials means a better screen. 100 radials, $\lambda/4$ long will perfectly screen the earth underneath the vertical. (This seems to contradict the previous item, but it doesn't—see Section 2.3.)
- Improving ground conductivity under the elevated radials by installing buried radials or a ground screen (not galvanically connected to the elevated radials, though!).

Another important issue is currents on the outside of the coaxial feed line. Fig 9-41D shows how unwanted currents can flow on the shield of the coaxial cable. In this situation, the coaxial feed line is just another conductor, a random-length radial. Return currents will flow in that conductor unless it is disconnected at the antenna's feed point. The question is now how can we disconnect the coaxial "radial" wire and not the coaxial feed line?

You must insert a current choke balun at the antenna feed

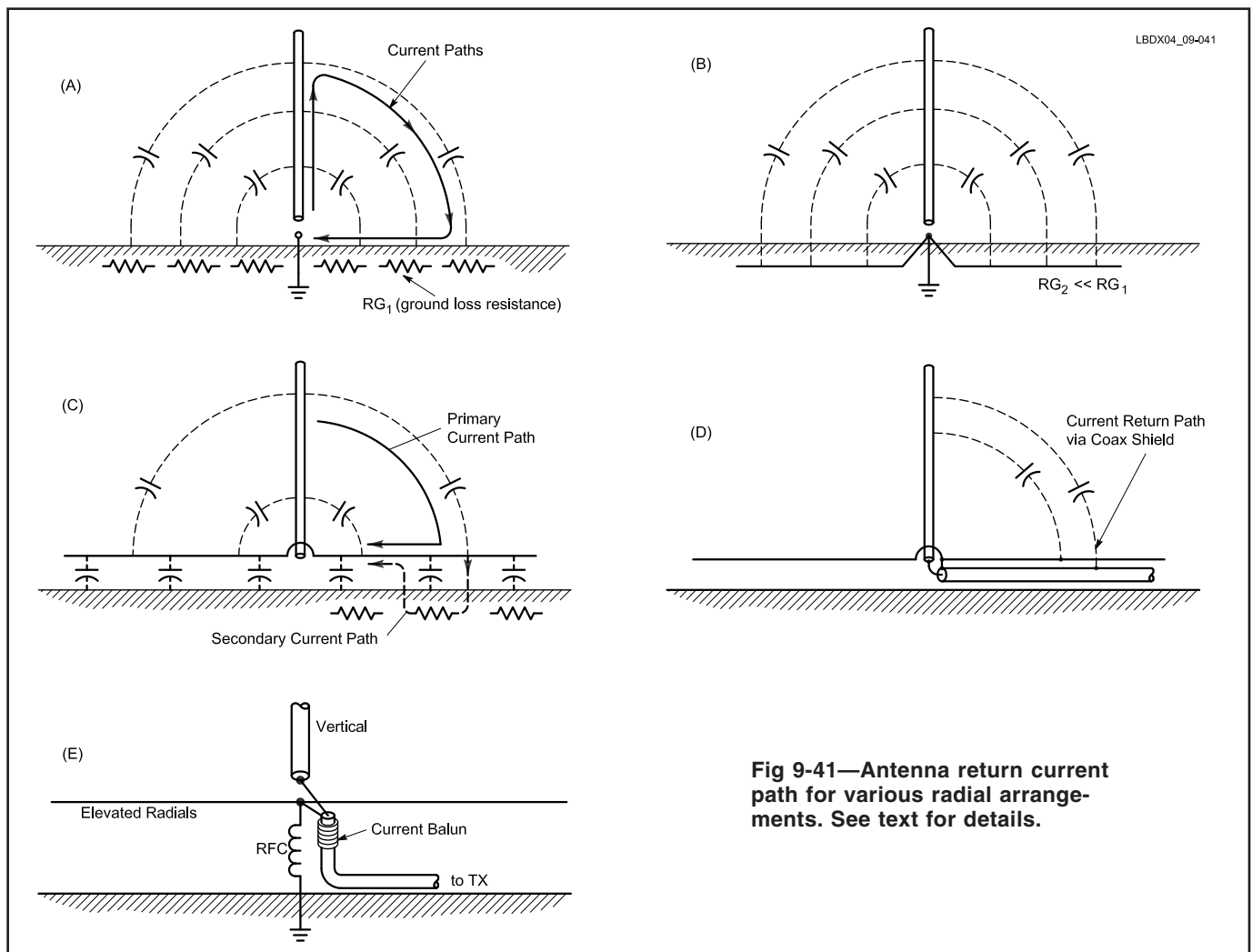

Fig 9-41—Antenna return current path for various radial arrangements. See text for details.

point (see Fig 9-41E). The high impedance the current balun presents to any currents on the outside of the coax shield effectively suppresses common-mode currents on the cable. Several types of current baluns are described in Chapter 6, Section 7. If you are forced to use (for layout reasons) $3\lambda/4$ feed lines in a Four-Square array, you will wind up with a lot of surplus coax length. Wind it all up in a coil and mount it as close as possible to the antenna feed point. This makes an excellent choke balun. It is always better to run the coax on or preferably in the ground, rather than supported on poles at a certain height, to prevent coupling and parasitic currents on the outer shield.

It also makes common sense to provide a dc ground for the common radial points. You can do this by connecting an RF choke (100 μ H or more) between the radial common point and a safety ground rod below the antenna feed point, as shown in Fig 9-41E.

If you use only a few radials each of them can radiate considerable near-field energy. They can induce currents on the feed line beyond where the choke balun has been inserted at the feed point. Burying the feed line can improve this situation. Feed lines supported off the ground are very sensitive to this kind of coupling. If you use only two radials, run the feed line at right angles to the two in-line radials. In other words, keep the feed line away from the near fields of the radials.

When using a number of elevated radials (eg, > 20), it is unnecessary to use a current balun since the screening effect of the radials will be sufficient to prevent common-mode antenna-return currents of any significant magnitude to flow on the coax outer shield.

2.2.15. Elevated radials in vertical arrays

When a vertical is used as an element in an array, an additional parameter arises when choosing the ideal radial length, at least if you are concerned about reducing horizontally polarized high-angle radiation of the array to a minimum. Careful layout of the radials is very important. Never run radials belonging to two different array elements in parallel. Design your layout such that coupling is minimized.

Zero coupling is of course achieved by using buried radials, terminated in bus bars where radials of adjacent elements meet one another. (See Chapter 13, Section 9.10). I should point out that if you use four 90° long radials on each element of an array, and have them laid out in such a manner that coupling does not exist between radials of adjacent elements, it may be just as good to use a single radial!

2.3. Buried or Elevated, Final Thoughts

It is clear, and it has been proven over and over in the real world, that an elevated radial system at a relatively low height is a valid alternative for a system of buried radials, if there is a good reason you can't put down a decent radial system in or on the ground. If you use only a small number of radials, perhaps 1 to 8, their task will be almost exclusively to efficiently collect the return currents of the vertical, and you will have to suffer substantial near-field losses in the ground, up to 5 dB. With a larger number the screening effect becomes important and near-field ground losses can be reduced by making use of the screening effect of a large number of radials. Elevated radials can have advantages such as:

- Providing the possibility of installing a decent ground system under very unfriendly circumstances, such as over rocky ground.
- More flexibility in matching, since the real ground is not resonant. An elevated radial system using only a few radials—maximum of four—can be made inductive or capacitive, which may be an asset in designing a matching system.

For using elevated radials I would propose the following guidelines:

- Put the radials up as high as possible.
- Use as many radials as possible, since this makes the radial system non-resonant.
- If you use a small number (< 16), install a ground screen.

If you have the space and if the ground is not too unfriendly, I would suggest you use buried radials however.

2.4. Evaluating the Radial System

Evaluating means measuring antenna field strength (FS), or measuring certain parameters for which we know the



Fig 9-42—Walter Skudlarek, DJ6QT, inspecting some of the radials used on the 160-meter vertical at ON4UN. Half of the radials are buried (where the garden is), and half are just lying on the ground in the back of the garden behind the hedge (where the XYL can't see the mess from the house!). In total, some 250 radials are used, ranging in length from 15 to 75 meters.

correlation with radiated FS. You cannot truly evaluate an antenna just by modeling it. You can develop, design and predict performance by modeling, but you cannot evaluate the actual performance of the antenna on a computer. However, there are some indirect measurements and checks that can and should be done:

2.4.1. Evaluating a buried-radial system

The classic way to evaluate the losses of a ground system is to measure the feed-point resistance of the vertical while steadily increasing the number of radials. The feed-point resistance will drop consistently and will approach a lower limit when a very good ground system has been installed. Be aware, however, that the intrinsic ground conductivity can vary greatly with time and weather, so it is recommended that you do such a test over a short time frame to minimize the effects of varying environmental factors on your tests (Ref 818, 819).

Peter Bobeck, DJ8WL, (now a Silent Key) performed such a test on his 23-meter long top-loaded (T) antenna. He added 50-meter long radials (on the ground) while measuring the feed-point impedance and found the following:

No. of radials	2	5	8	14	20	30	50
Impedance, Ω	122	66	48	39	35	32	29

Incidentally, eight radials look like a perfect match to 50- Ω coax, but the system efficiency for that case was below 50%!

Don't be surprised if the impedance gets lower than 36 Ω with a full-size $\lambda/4$ vertical. It first surprised me when I measured about 20 Ω for my 160-meter full-size $\lambda/4$ vertical made with a freestanding tower, but that was because of its

very large effective diameter.

For calculating antenna efficiency, you can use the values from Table 9-1 that lists the equivalent resistance of buried radial systems in good-quality ground. For poor ground, higher resistances can be expected, especially with only a few radials.

Measuring the impedance of a vertical and watching it decrease as you add radials tells us nothing about the near-field absorption ground losses. It only gives us an indication of the I^2R losses that determine return-current collecting efficiency.

Periodic visual inspections of the radial system for broken wires and loose or corroded connections, etc will assure continued efficient operation. **Fig 9-42** shows DJ6QT examining the radials of the ON4UN 160-meter vertical. If you bury the radials, it is a good idea to make them accessible anyhow just where they connect to the bus bar. This way you can periodically check with a snap-on current meter if the radial still carries any current on transmit. If it doesn't, maybe the radial is broken at a short distance from the connection point.

2.4.2. Evaluating an elevated-radial system

Whether you have 1, 2 or 16 elevated radials, if these radials are the only antenna-current return paths (that is, the elevated radials are *not* connected to the lossy ground), the measured real part of the antenna impedance will not change. There is no gradual decrease of feed-point impedance as you increase the number of radials.

Measuring the antenna impedance does *not* give you any indication of near-field absorption ground losses. The only test you can perform on an elevated radial system is to measure the radial current, although this has little, if any, correlation

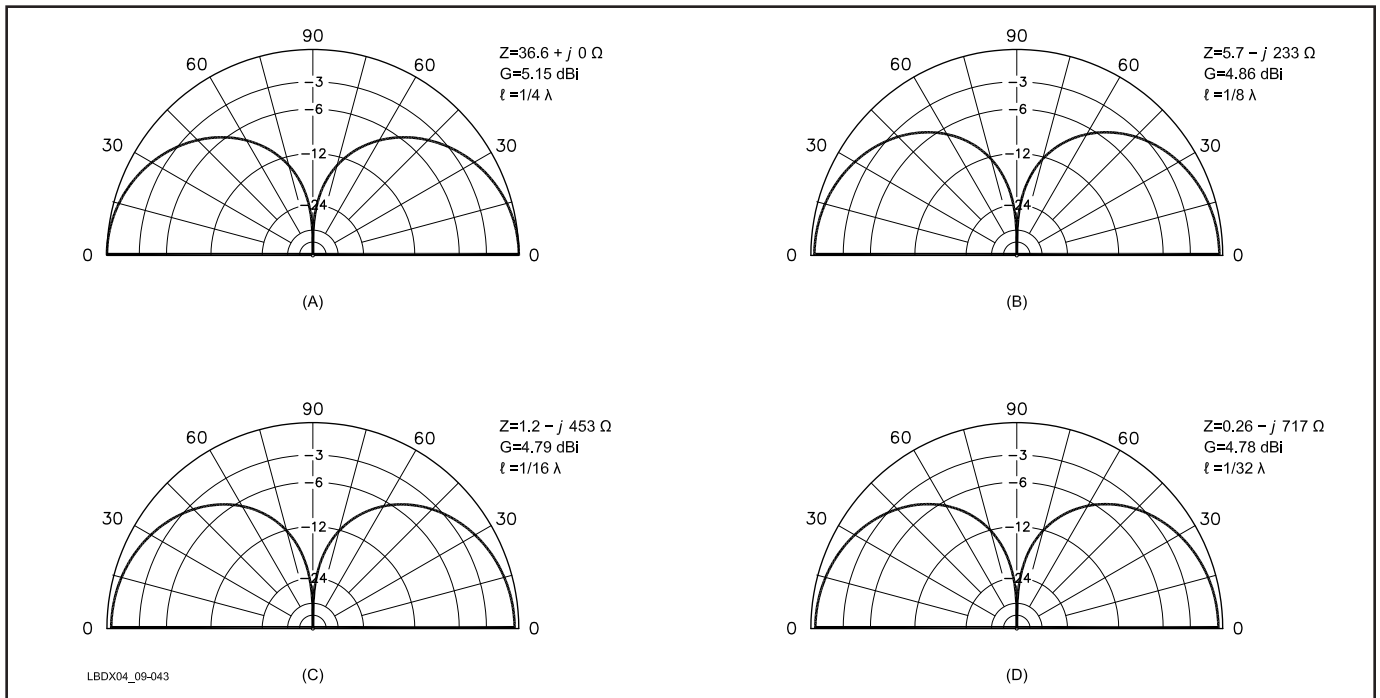

Fig 9-43—Elevation-plane radiation patterns and gain in dBi of verticals with different heights. The 0-dB reference for all patterns is 5.2 dBi. Note that the gain as well as the shape of the radiation patterns remain practically unchanged with height differences. The patterns were calculated with *ELNEC* over perfect ground, using a modeling frequency of 3.5 MHz and a conductor diameter of 2 mm. At A, height = $\lambda/4$. At B, height = $\lambda/8$. At C, height = $\lambda/16$. At D, height = $\lambda/32$.

with low-angle field strength. Nevertheless, when using only a few radials (2 to 8) it is a good idea to check the radial currents, and to make sure they are similar (\pm a few percent of one another).

Do regular inspections of your current balun. I would recommend to periodically measure its effectiveness by checking its inductance. This should be measured at the operating frequency.

3. SHORT VERTICALS

We usually consider verticals as being *short* if they are physically shorter than $\lambda/4$. Short verticals have been described in abundance in the amateur literature (Ref 771, 794, 746, 7793

and 1314). Gerd Janzen published an excellent book on this subject, *Kurze Antennen* (in German). Unfortunately, this was completely based on antenna modeling, where in my opinion real-world measured results are greatly lacking (Ref 7818).

The radiation pattern of a short vertical is essentially the same as that for a full-size $\lambda/4$ vertical. **Fig 9-43** shows the vertical radiation patterns of a range of short verticals over perfect ground, calculated using *ELNEC*. Notice that the gain is essentially the same in all cases (the theoretical difference is less than 0.5 dB).

If those short verticals over perfect ground are in essence almost as good as their full-size ($\lambda/4$) counterparts, why aren't we all using short verticals? A short monopole exhibits a feed-point impedance with a resistive component that is much

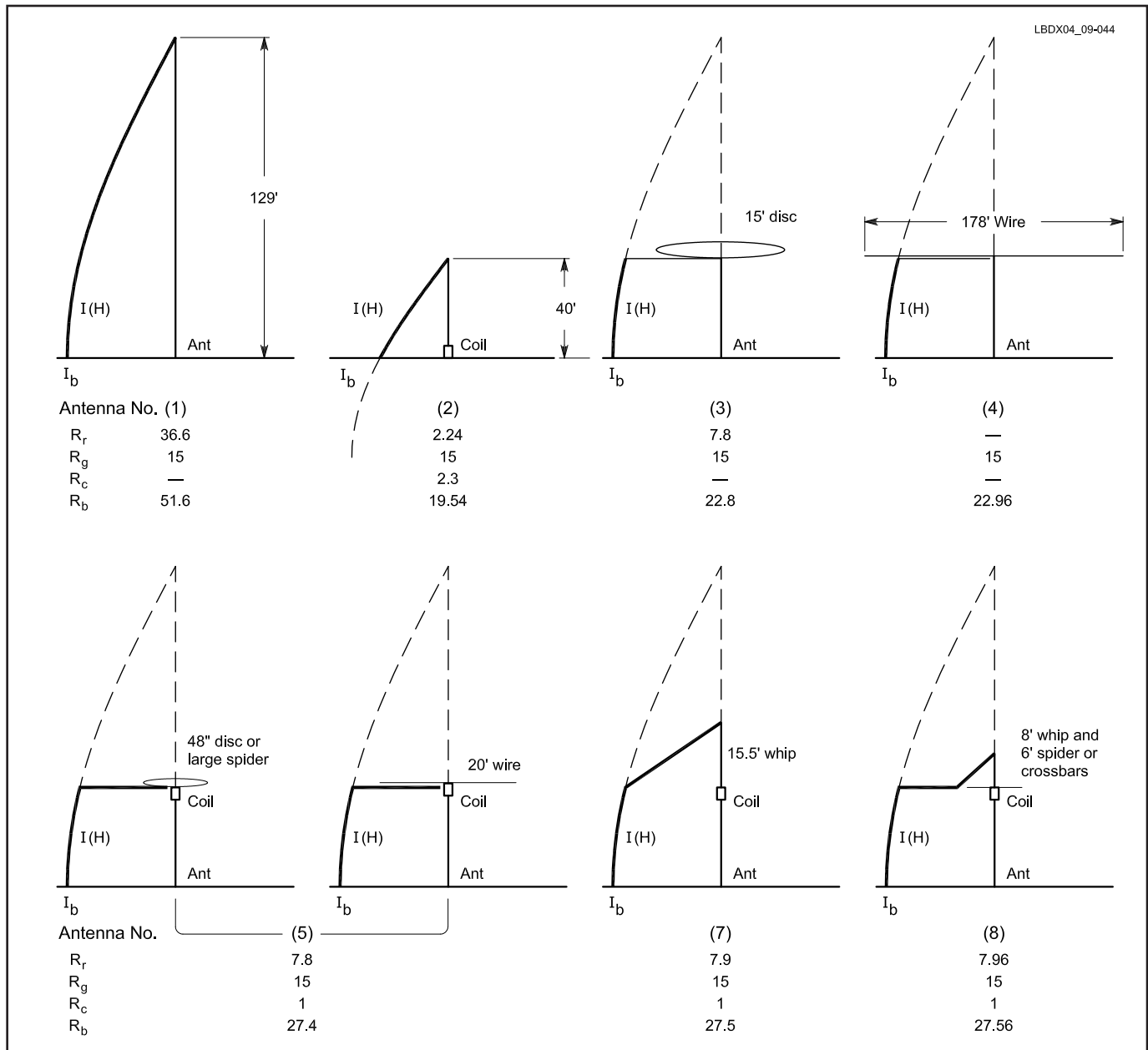

Fig 9-44—The antennas described in the text are shown with their current distributions, radiation resistances R_r , assumed ground loss resistance R_g , coil loss R_c (if any), total base input resistance R_b , base current I_b for 1000-W input to the antenna, and finally radiating efficiency in % (Source: "Evaluation of the Short Top Loaded Vertical" by W7XC, QST March 1990.)

smaller than 36.6Ω and a reactive component that is highly capacitive. These two factors can make a short vertical more difficult to handle than a bigger one. To feed a short vertical with low losses using a coaxial feed line, you must first get rid of the reactive part and increase the real part of the feed impedance up to 50Ω . This requires *loading* and *matching* the vertical and these can greatly impact efficiency.

Short verticals can be loaded to be resonant at the desired operating frequency in different ways. Various loading methods will be covered in this section, and the radiation resistance for each type will be calculated. Design rules will be given, and practical designs are worked out for each type of loaded vertical. Different loading methods will be compared in terms of efficiency.

Loading a short vertical means canceling the reactive part of the impedance to bring the antenna to resonance. The simplest way is to add a coil at the base of the antenna, a coil with an inductive reactance equal to the capacitive reactance shown by the short vertical. This is the so-called *base-loading method*. Fig 9-44 shows a number of classic loading schemes for short verticals, along with the current distribution along the antenna. Remember from Section 1.2 that the radiation resistance is a measure of the area under the current-distribution curve. Also remember from Section 1.3 that the radiation efficiency is given by:

$$\text{Eff} = \frac{R_{\text{rad}}}{R_{\text{rad}} + R_{\text{loss}}}$$

The real issues with short verticals are *efficiency* and *bandwidth*. Let us examine these issues in detail. With short verticals the numerator of the efficiency formula decreases in value (smaller R_{rad}), and the term R_{loss} in the denominator is likely to increase (losses of the loading devices such as coils). This means we have two terms, which tend to decrease the efficiency of loaded verticals. Therefore maximum attention must be paid to these terms by

- Keeping the radiation resistance as high as possible (which is *not* the same as keeping the feed-point impedance as high as possible).
- Keeping the losses of the loading devices as low as possible. Maximum radiation resistance occurs when current integrated over the vertical section is as high as possible, which means maximum current mid-height in the vertical section. With very short verticals the current distribution is almost constant and the exact position of the maximum becomes irrelevant.

3.1. Radiation Resistance

The procedure for calculating the radiation resistance was explained in Section 1.2, where we found that for a $\lambda/4$ vertical made with a very small size conductor is 36.6Ω . (See Fig 9-44). We will now analyze the following types of short verticals, all of which are about 30% of full-size quarter-wave (approximately 12 meters high on 160 meters) or 27.5° long:

1. Base loaded.
2. Top loaded.
3. Center loaded.
4. Base plus top loaded.
5. Linear loaded.

3.1.1. Base loading

The radiation resistance can be calculated as defined in Section 1.2. A trigonometric expression that gives the same results, is given below (Ref 742).

$$R_{\text{rad}} = 36.6 \times \frac{(1 - \cos L)^2}{\sin^2 L} \quad (\text{Eq 9-7})$$

where L = the length of the monopole in degrees ($1 \lambda = 360^\circ$).

According to Eq 9-7, the radiation resistance of the base-loaded vertical (electrical length = 27.5°) is 2.2Ω . (See Fig 9-44.)

J. Hall, K1TD, derived another equation (Ref 1008):

$$R_{\text{rad}} = \frac{L^{2.736}}{6096} \quad (\text{Eq 9-8})$$

where L = electrical length of the monopole in degrees.

This simple equation yields accurate results for monopole antenna lengths between 70° and 100° , but should be avoided for shorter antennas. A practical design example is described in Section 3.6.1.

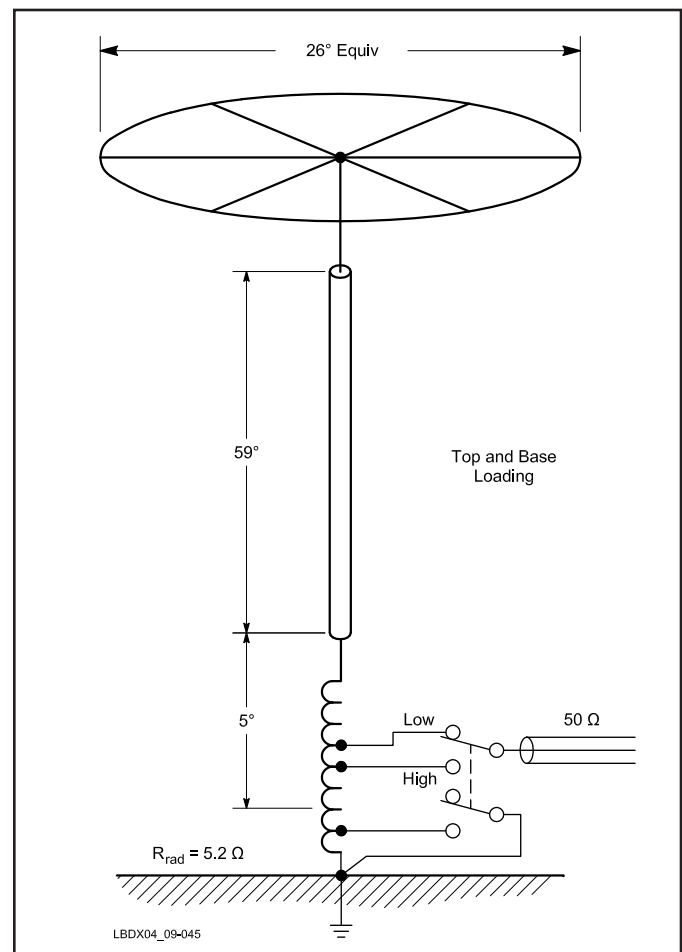
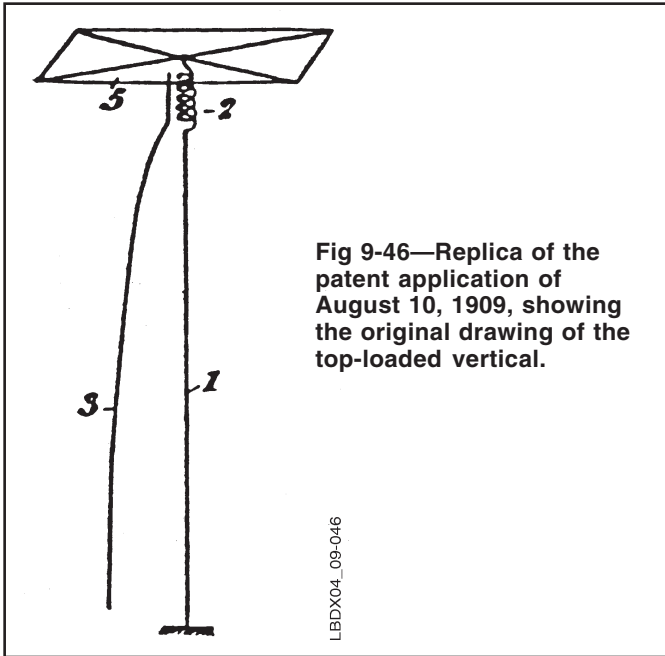

Fig 9-45—Instead of series-feeding the antenna, we can look for a tap on the coil that gives 50Ω . The coil serves two purposes: Some base loading and also impedance matching. Using a DPDT relay you could make provisions for a perfect $50\text{-}\Omega$ match on two frequencies; eg, on CW and on phone.



3.1.2. Top loading

The patent for the top-loaded vertical was granted to Simon Eisenstein of Kiev, Russia, in 1909. **Fig 9-46** is a copy of the original patent application, where you can see a combined loading coil plus top-hat loading configuration. The resulting current distribution is also shown.

The tip of the vertical antenna is the place where there is no current, and maximum voltage. This is the place where *capacitive* loading is most effective, and *inductive* loading (loading coils) is least effective. In some cases, inductive loading is combined with capacitive top loading. Top loading is achieved by one of the following methods (see **Fig 9-47**):

- **Capacitance top hat:** In the shape of a disk or the spokes of a wheel at the top of the shortened vertical. Details of how to design a vertical with a capacitance hat are given in Section 3.6.3.
- **Flat-top wire loading (T antenna):** The flat-top wire is symmetrical with respect to the vertical. Equal currents flowing outward in both flat-top halves essentially cancel the radiation from the flat-top wire. For design details see Section 3.6.4.

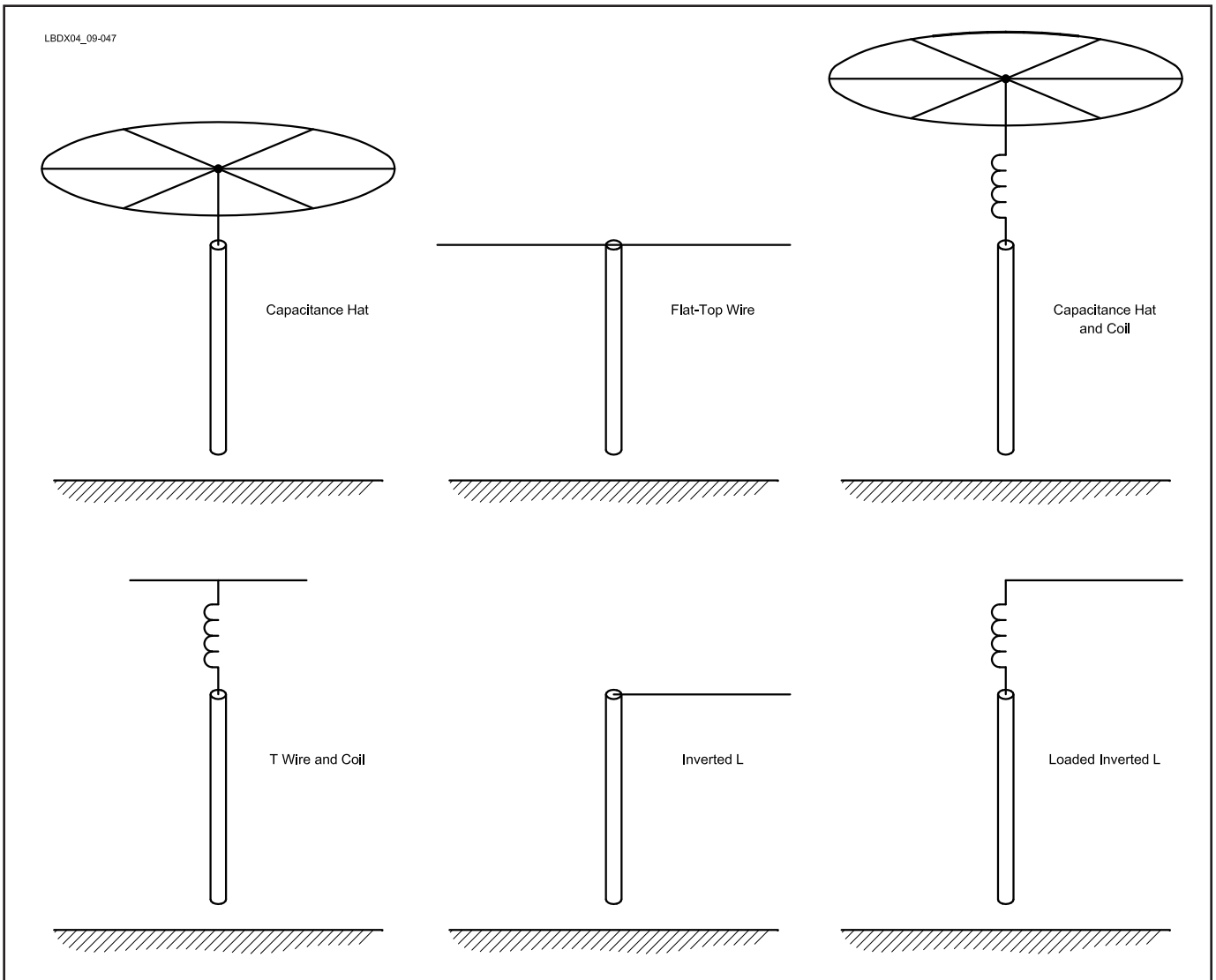

Fig 9-47—Common types of top loading for short verticals. The inverted L and loaded inverted L are not true verticals, since their radiation patterns contain horizontal components.

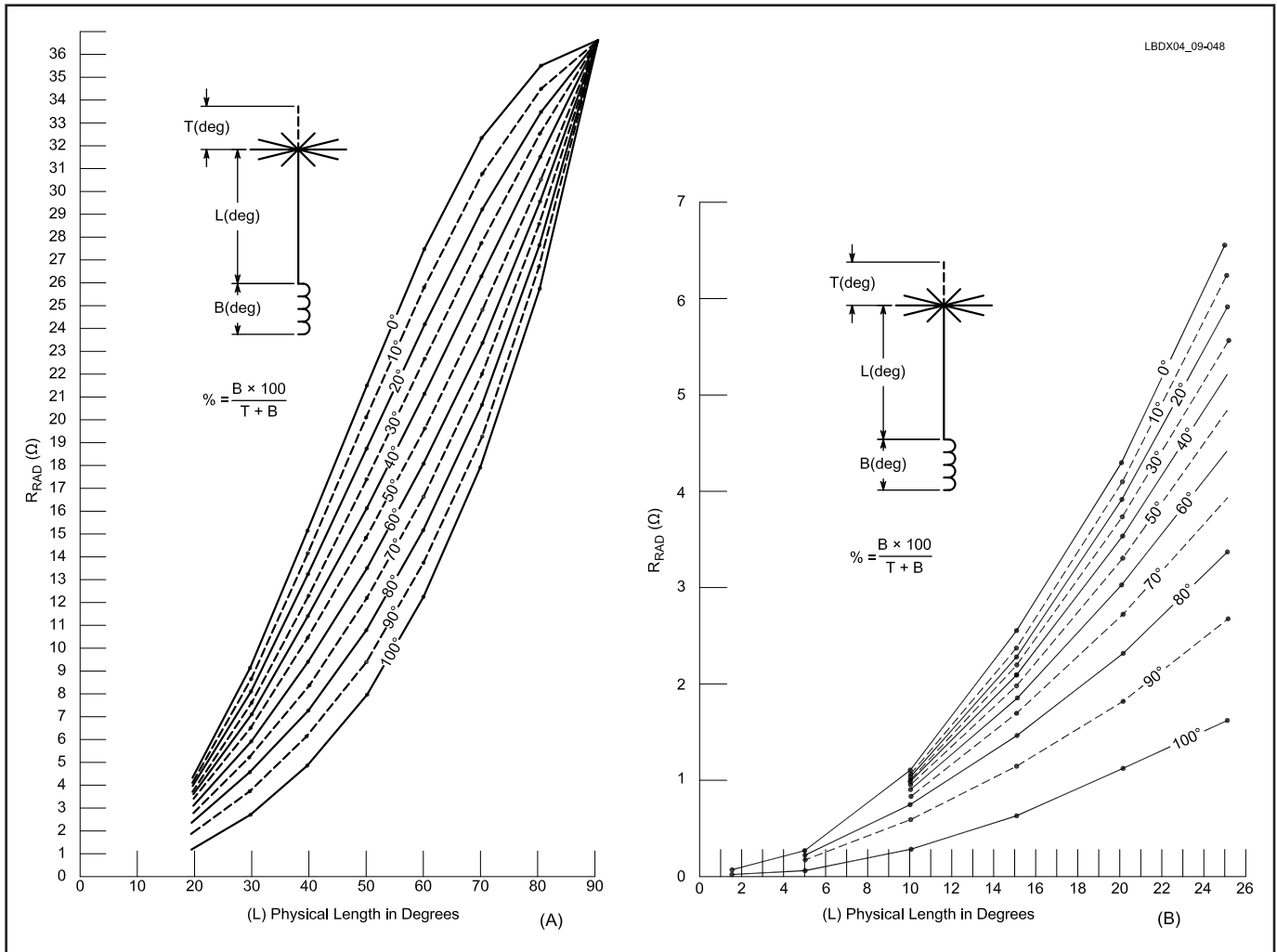

Fig 9-48—Radiation resistances of a monopole with combined top and base loading. Use the chart at B for shorter monopoles to obtain better accuracy.

- **Coil with capacitance hat:** In many instances a loading coil is used in combination with a capacitance hat to load a short monopole. This may be necessary, as otherwise an unusually large capacitance hat may be required to establish resonance at the desired frequency.
- **Coil with flat-top wire:** This loading method is similar to the coil with capacitance hat (see Section 3.6.5 for design example).
- **Inverted L:** This configuration is not really a top-loaded vertical, since the horizontal loading wire radiates along with the vertical mast to produce both vertical and horizontal polarization. Inverted-L antennas are covered separately in Section 7.
- **Coil with wire:** This too is not really a loaded short vertical, but a form of a loaded inverted L.

For calculating the radiation resistance of the top-loaded vertical, it is irrelevant which of the above loading methods is used. For a given vertical height, all achieve the same radiation resistance. However, when we deal with efficiency (where both R_{rad} and R_{loss} are involved) the different loading methods may behave differently because of different loss resistances.

The radiation resistance can be calculated as defined in Section 1.2. A trigonometric expression with the same results

is given below (Ref 742 and 794):

$$R_{rad} = 36.6 \times \sin^2 L \quad (\text{Eq 9-9})$$

where L is the length of the vertical monopole in degrees.

The 27.5° short monopole with pure end loading (Fig 9-44) has a radiation resistance of

$$R_{rad} = 36.6 \times \sin^2 27.5^\circ = 7.8 \Omega$$

The radiation resistance of top-loaded verticals can be read from the charts in Fig 9-48. For top-loaded verticals, use only the 0% curves.

3.1.3. Center loading

The center-loaded monopole of Fig 9-44 is loaded with a coil positioned along the mast. The antenna section above the coil is often called the *whip*.

- Length of mast below the coil = 27.5°
- Length of whip above the coil = 3° (4.7 meters on 1.9 MHz)

The radiation resistance can be calculated as defined in Section 1.2. A trigonometric expression that gives the same results is shown below (Ref 42 and 7993):

$$R_{\text{rad}} = 36.6 \times (1 - \sin^2 t_2 + \sin^2 t_1) \quad (\text{Eq 9-10})$$

where

t_1 = length of vertical below loading coil (27.5°)

$t_2 = 90^\circ -$ length of vertical above loading coil
(the whip, 3°) = 87°

Using this formula, R_{rad} is calculated as = 7.9Ω . Note that R_{rad} is essentially the same as the other top loaded schemes. The whip is often used in mobile antennas to fine-tune the antenna to resonance.

3.1.4. Combined top and base loading

Top and base loading are quite commonly used together, as shown in Fig 9-45. Top loading is often done with capacitance-hat loading, or even more frequently in the shape of two or more flat-top wires. If a wide frequency excursion is required (eg, 3.5 to 3.8 MHz), you can load the vertical to resonate at 3.8 MHz using the top-loading technique. When operating on 3.5 MHz, a little base loading is added to establish resonance at the lower frequency.

A trigonometric expression for R_{rad} is given below (Ref 742 and 7993):

$$R_{\text{rad}} = 36.6 \times \frac{(\sin t_1 - \sin t_2)^2}{\cos^2 t_2} \quad (\text{Eq 9-11})$$

where

t_1 = electrical height of vertical mast

t_2 = electrical length provided by the base-loading coil

In our example shown in Fig 9-45, $t_1 = 59^\circ$ and $t_2 = 5^\circ$

$$R_{\text{rad}} = 36.6 \times \frac{(\sin 59^\circ - \sin 5^\circ)^2}{\cos^2 5^\circ} = 21.9 \Omega$$

By replacing some of the top loading by base loading, the radiation resistance has only dropped a few tenths of an ohm. Fig 9-44 shows the radiation resistance for monopoles with combined top and base loading. The physical length of the antenna (L) plus top loading (T) plus base loading (B) must total 90° . The calculation of the required capacitance and the dimensions of the capacitance hat are explained further in Section 3.6.2.

When the antenna has a large capacitance hat compared to the distributed capacitance of the structure, there is no reason to put the coil high on the structure. Current distribution will be essentially the same no matter where you put the coil, even when the antenna is *far* from self-resonance with just the hat. We can simply use a large hat and put a coil at the base, where it can do double-duty for impedance matching and loading, and we can reach it easily for adjustment, as shown in Fig 9-45.

3.1.5. Linear loading

Linear loading is defined as replacing a loading coil at a given place in the vertical with a linear-loading section, which resembles a shorted stub, at the same place in the vertical. This places the two conductors of the loading device in parallel with the radiating element. Due to the current *not* being out-

of-phase in the loading device, the device will radiate. The R_{rad} of the antenna will be slightly higher than if we were using a loading coil in the same place.

This linear-loading technique described above is used on the Hy-Gain 402BA shortened 40-meter beam, where linear loading is used at the center of the dipoles. It is also used successfully on the KLM 40 and 80-meter shortened Yagis and dipoles, where linear loading is applied at a certain distance from the center of the elements, but where the linear loading devices were *not* parallel to the elements, introducing some unwanted radiation. This reduced the directional characteristics of the antenna.

In recent years the better Yagi designs for 80 meters have employed optimized high-Q loading coils rather than linear-loading devices, with great success (see Chapter 13).

3.2. Keeping the Radiation Resistance High

As stated before, this is *not* the same as keeping the feed-point impedance high! Using any kind of transformers, such as folded elements or any other type of matching systems do *not* change the radiation resistance. The rule for keeping the radiation resistance as high as possible is simple:

1. Use as long a vertical as possible (up to 90°).
2. Use top-capacitance loading rather than center or bottom loading. Fig 9-48 gives the radiation resistance for monopoles with combined base and top loading. The graphs clearly show the advantage of top loading.

The values of R_{rad} given in these figures can be used for antennas with diameters ranging from 0.1° to 1° ($360^\circ = 1 \lambda$). J. Sevvick, W2FMI, (Ref 818) obtained very similar results experimentally, while the values in the figures mentioned above were derived mathematically.

For a given physical size, the way to maximize efficiency is to make current as large and uniform as possible over the maximum available vertical distance. The solution is to end-load the antenna with a large hat or some other form of termination that does *not* return to earth. The only thing fancy shunt tuning schemes or multiple drop wires do is to make the feed line see a new impedance.

Top loading with sloping wires is attractive from a mechanical point of view. Sloping loading wires do add capacitance, but only marginally increase R_{rad} , because of the shielding effect of the sloping wires around the vertical. In Chapter 7, we saw how W8JI uses sloping top-hat wires in his 8-circle receiving array, but bear in mind that in this receiving antenna and the designer is not after a larger R_{rad} but rather is trying to lengthen the vertical electrically.

3.3. Keeping Losses Associated with Loading Devices Low

- **Capacitance hat:** The losses associated with a capacitance hat are negligible. When applying top-capacitance loading, especially on 160 meters, the practical limitation is likely to be the size (diameter) of the top hat. Therefore, when designing a short vertical it is wise to start by dimensioning the top hat.
- **T-wire top loading:** This method is lossless, as with the capacitance hat. It may not always be possible, however, to have a perfectly horizontal top wire. Slightly drooping of top-loading wires is just as effective, and when used in pairs (each wire of a pair being in-line with the second

wire) the radiation from these loading wires is negligible.

- **Linear-loading:** W8JI measured the Q of typical linear loading devices and found an amazing low figure of between 50 and 100, while loading coils of moderate quality easily reach an unloaded Q of 200 and well-designed and optimized coils may reach a Q of well over 400. Tom, W8JI remarks: “For example, the Q of a 400 ohm reactance with a #14 folded wire stub is much less than 100. I can easily obtain a Q of 300 with the same size wire in a conventional coil.”
- **Loading coil:** Even large loading coils are intrinsically lossy. The equivalent series loss resistance is given by:

$$R_{\text{loss}} = \frac{X_L}{Q} \quad (\text{Eq 9-12})$$

where

- X_L = inductive reactance of the coil
- Q = Q (quality) factor of the coil

Base loading requires a relatively small coil, so the Q losses will be relatively low, but the R_{rad} will be low as well. See Section 3.6 for practical design examples with real-life values.

Top loading requires a large-inductance coil, with correspondingly larger losses, while in this case the R_{rad} is much higher.

As mentioned above, unloaded Q factors of 200 to 300 are easy to obtain without special measures. Well-designed and carefully built loading coils can yield Q factors of up to 800 (Ref 694 and 695). W8JI, wrote: “The most detailed and accurate loading inductor text readily available to amateurs appears in the chapter “Reactive Elements and Impedance Limits” in Kuecken’s book “Antennas and Transmission Lines” (Ref 696). I’ve measured hundreds of inductors. A typical B&W Mininductor or Airdux coil of #12 wire operated far from self-resonance with a form factor of 2:1 L/D has a Q in the 300 range. Optimum Q almost always occurs with bare wire space wound one turn apart, but optimum L/D can range from 0.5 to 2 or more depending on how far below self-resonance you operate the inductor and what is around the inductor and how big the conductors in the coil are.

Large optimal edge-wound or copper tubing coils can get into the Q ~800 range. I’ve never in my life seen an inductor of reasonable reactance above that Q, and very few make it that high.”

3.4. Short-Vertical Design Guidelines

From the above considerations we can conclude the following:

- Make a short vertical physically as long as possible.
- Make use of top loading (capacitance hat or horizontal T wires) to achieve the highest radiation resistance possible.
- Use the best possible radial system.
- Design and build your own loading coils with great care (high Q).
- Take extremely good care of electrical contacts, contacts between antenna sections, between the antenna and the loading elements. This becomes increasingly important when the radiation resistance is low.

Though you may be able to build small verticals with low

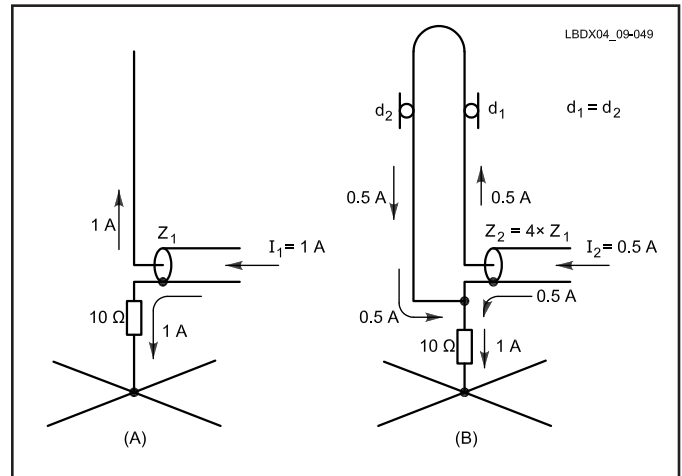

Fig 9-49—The same net current flows in the ground system, whether an open or a folded element is used. This is clearly illustrated for both cases. See text for details.

intrinsic losses, it may not always be possible to improve the losses in the ground-return circuit (radials and ground) to a point where a small loaded vertical achieves good efficiency. Small loaded verticals will often be imposed by area restrictions, which may also mean that an extensive and efficient ground (radial) system may be excluded. Keep in mind that with short loaded verticals, the ground system is even more important than with a full-size vertical.

It is a widespread misconception that vertical antennas don’t require much space. Nothing is farther from the truth. Verticals take a lot of space! A good ground system for a short vertical takes much more space than a dipole, unless you live right at the coast, over saltwater, where you might get away with a simple ground system. By the way, it is the saltwater that allows a short loaded verticals to produce such excellent signals on many DXpeditions. Remember VKØIR (Heard Island) and ZL7DK (Chatham Island), just to name a couple of them.

3.4.1. Verticals with folded elements

Another common misconception is that folded elements increase the radiation resistance of an antenna, and thus increase the system efficiency. However, the radiation resistance of a folded element is not the same as its feed-point resistance.

A folded monopole with two equal-diameter legs will show a feed-point impedance with the resistive part equal to $4 \times R_{\text{rad}}$. The higher feed-point impedance does not reduce the losses due to low radiation resistance, however, since with the folded element the lower feed current now flows in one more conductor, totaling the same loss. In a folded monopole, the same current ends up flowing through the lossy ground system, resulting in the same loss whether a folded element is used or not.

This is illustrated in **Fig 9-49**. In the non-folded situation in Fig 9-49A it is clear that the total 1 A current flows through the 10-Ω equivalent ground-loss resistance. The ground loss is $I^2 \times R = 10$ W. Figure 9-49B shows the folded-element situation. In this example equal-diameter conduc-

tors are assumed; hence the feed impedance is four times the impedance of the single-conductor-equivalent vertical, and the current is half the value of the same antenna with a single conductor. Thus, 0.5 A flows in the folded-element wire and from the feed point down to the 10-Ω resistor. There is another 0.5 A coming down the folded wire and also going to the top of the 10-Ω resistor. In the ground system through the 10-Ω ground loss resistor, we have a total current of 1 A flowing, the same as with the unfolded vertical. The loss is again $I^2 \times R = 10 \text{ W}$.

In other words, the impedance transformation of the folded monopole also transforms the ground loss part of the equation in the same way as it does for the radiation resistance, and there is no net improvement. It is just another form of transformer and is no different than adding a toroidal step-up transformer at the base of a regular monopole.

Although the folded monopole does not gain anything in efficiency due to the impedance transformation it does have some advantages. The impedance transformation will result in a higher impedance that might be more easily matched by a more efficient network than would be required by a plain monopole. The folded monopole has some advantages in lightning protection due to the possibility of dc grounding the structure. And the folded monopole may have a wider bandwidth due to the larger effective diameter of the two conductors (see also Chapter 8, Section 1.4.1).

Fig 9-50 shows the effective normalized diameter of two parallel conductors, as a function of the conductor diameters and spacing (from *Kurze Antennen*, by Gerd Janzen, ISBN 3-440-05469-1). A folded element consisting of a 5-cm OD tube and a 2-mm OD wire ($d_1/d_2 = 25$), spaced 25 cm has an effective round conductor diameter of $0.6 \times 25 = 15 \text{ cm}$.

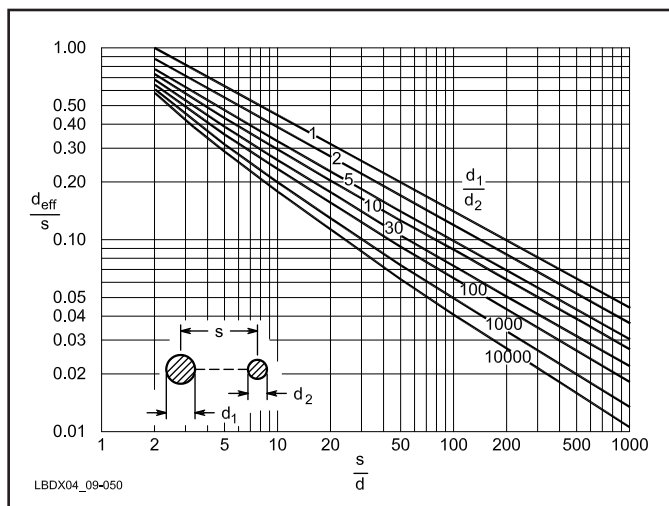

Fig 9-50—Normalized effective antenna diameters of a folded dipole using two conductors of unequal diameter, as a function of the individual conductor diameters d_1 and d_2 , as well as the spacing between the two conductors (S). (After Gerd Janzen, *Kurze Antennen*)

3.5. SWR Bandwidth of Short Verticals

3.5.1. Calculating the 3-dB bandwidth

One way of defining the Q of a vertical is:

$$Q = \frac{Z_{\text{surge}}}{R_{\text{rad}} + R_{\text{loss}}} \quad (\text{Eq 9-13})$$

Z_{surge} is the characteristic impedance of the antenna seen as a short single-wire transmission line. The surge impedance is given by:

$$Z_{\text{surge}} = 60 \left[\ln \left(\frac{4h}{d} \right) - 1 \right] \quad (\text{Eq 9-14})$$

where

h = antenna height (length of transmission line)

d = antenna diameter (transmission-line diameter)

and where values for h and d are in the same units

The 3-dB bandwidth is given by:

$$\text{BW}_{3\text{dB}} = \frac{f}{Q} \quad (\text{Eq 9-15})$$

where f = the operating frequency.

Example:

Assume a top-loaded vertical 30 meters high, with an effective diameter of 25 cm and a capacitance hat that resonates the vertical at 1.835 MHz.

Using Eq 9-14: $Z_{\text{surge}} = 310 \Omega$

The electrical length of the vertical is:

$$\frac{1.835}{300 \times 0.96} \times 30 \text{ m} \times 360^\circ = 68.8^\circ$$

Using Eq 9-7: $R_{\text{rad}} = 31.8 \Omega$

Assume: $R_{\text{ground}} = 10 \Omega$ (an average ground system).

Using Eq 9-13:

$$Q = \frac{310}{31.810} = 7.42$$

$$\text{Using Eq 9-15: } \text{BW}_{3\text{dB}} = \frac{1.835}{7.42} = 0.247 \text{ MHz}$$

3.5.2. The 2:1 SWR bandwidth

A more practical way of knowing the SWR bandwidth performance is to model the antenna at different frequencies, using eg, *MININEC* or *EZNEC*. The Q of the vertical is a clear indicator of bandwidth. Antenna Q and SWR bandwidth are discussed in Chapter 5, Section 3.10.1.

Table 9-5 shows the results obtained by modeling full-size quarter-wave verticals of various conductor diameters. Both the perfect as well as the real-ground case are calculated. The vertical with a folded element clearly exhibits a larger SWR bandwidth than the single-wire vertical. Note that with a tower-size vertical (25-cm diameter), both the CW as well as the phone DX portions of the 80-meter band are well covered. If a wire vertical is planned (eg, suspended from trees), the

Table 9-5

Quarter-Wave Verticals on 80 Meters

Z_t , SWR_t and Q_t indicate the theoretical figures assuming zero ground loss. Z_g , SWR_g and Q_g values include an equivalent ground resistance of 10 Ω .

Diameter		2 mm (0.08")	40 mm (1.6")	250 mm (10")
3.5 MHz	$Z_t =$	31.6 - j 31.4	31.4 - j 23.5	31.1 - j 16.7
	$Z_g =$	41.6 - j 35.9	41.4 - j 23.5	41.1 - j 16.7
	$SWR_t =$	2.8:1	2.0:1	1.7:1
	$SWR_g =$	2.2:1	1.7:1	1.5:1
3.65 MHz	$Z_t =$	35.9	35.9	35.9
	$Z_g =$	45.9	45.9	45.9
	$SWR_t =$	1:1	1:1	1:1
	$SWR_g =$	1:1	1:1	1:1
3.8 MHz	$Z_t =$	40.0 + j 35.5	40.9 + j 24.5	41.1 + j 16.6
	$Z_g =$	50.0 + j 35.5	40.9 + j 24.5	51.1 + j 16.6
	$SWR_t =$	2.5:1	1.9:1	1.6:1
	$SWR_g =$	2.1:1	1.7:1	1.4:1
All	$Q_t =$	12.1	8.1	5.6
	$Q_g =$	9.5	6.4	4.4

Table 9-6

Verticals with 40-mm OD for 80 Meters

Z_t , SWR_t and Q_t are the values for a 0- Ω ground resistance. Z_g , SWR_g and Q_g relate to an equivalent ground resistance of 10 Ω .

Frequency		$\lambda/8$ Long (9.9 m) (28.4 ft)	$3\lambda/16$ Long (12.6 m) (41.3 ft)
3.5 MHz	$Z_t =$	5.37 - j 340	9.3 - j 237
	$Z_g =$	15.37 - j 340	19.3 - j 237
	$SWR_t =$	15.7:1	6.0:1
	$SWR_g =$	3.6:1	2.7:1
3.65 MHz	$Z_t =$	5.9 - j 319	10.3 - j 217
	$Z_g =$	10.5 - j 319	20.3 - j 217
	$SWR_t =$	1:1	1:1
	$SWR_g =$	1:1	1:1
3.8 MHz	$Z_t =$	6.47 - j 299	11.4 - j 198
	$Z_g =$	16.47 - j 299	21.4 - j 198
	$SWR_t =$	12.3:1	4.9:1
	$SWR_g =$	3.3:1	2.4:1
All	Q_{F}	42	23
	Q_{G}	15	12

folded version is to be preferred. Matching can easily be done with an L network.

It is evident that loaded verticals exhibit a much narrower bandwidth than their full-size $\lambda/4$ counterparts. With short verticals, the quality of the ground system (the equivalent loss resistance) plays a very important role in the bandwidth of the antenna. **Table 9-6** shows the calculated impedances and SWR values for short top-loaded verticals. The same equivalent ground resistance of 10 Ω used in Table 9-5 has a very drastic influence on the bandwidth of a very short vertical. Note the drastic drop in Q and the increase in bandwidth with the 10- Ω ground resistance.

Two factors definitely influence the SWR bandwidth of

a vertical of a given length: the conductor diameter and the total loss resistance. We only want to increase the conductor diameter to increase the bandwidth where possible. If you want to use the loss resistance to increase the bandwidth, you might as well use a dummy load for an antenna. After all, a dummy load has a large SWR bandwidth and the worst possible radiating efficiency!

If you use a coil for loading a vertical (center or top loading), you can see that for a given antenna diameter, the bandwidth will decrease as the antenna is shortened and the missing part is partly or totally replaced by a loading coil. Then with more shortening, the bandwidth will begin to increase again as the influence of the equivalent resistive loss in the coil begins to affect the bandwidth of the antenna.

If you measure an unusually broad bandwidth for a given vertical design,

you should suspect a poor-quality loading coil or some other lossy element in the system. (Or did you forget a ground system?)

3.6. Designing Short Loaded Verticals

Let us review some practical designs of short loaded verticals (Ref 794).

3.6.1. Base coil loading

Assume a 24-meter high vertical with an effective diameter of 25 cm, which you can use as a $3\lambda/8$ vertical on 80 meters. You can also resonate it on 160 meters using a base-mounted loading coil (**Fig 9-51**). The electrical length

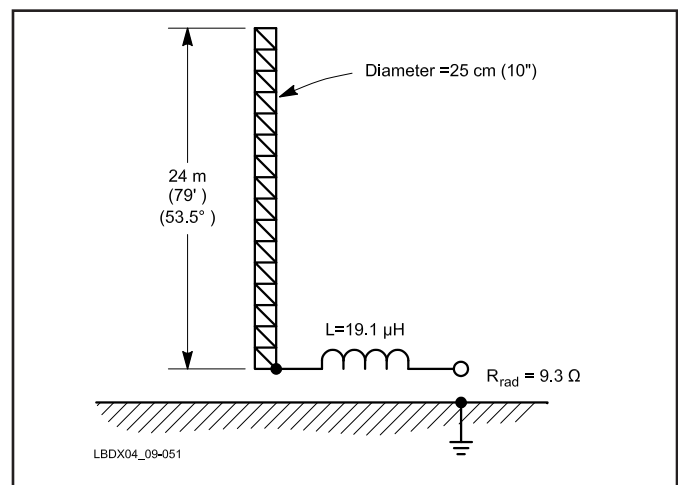

Fig 9-51—Base-loaded tower for 160 meters. See text for details on how to calculate the radiation resistance as well as the value of the loading coil. The loss resistance is effectively in series with the radiation resistance. With 60 $\lambda/8$ radials over good ground, the feed-point impedance will be approximately 20 Ω and the radiation efficiency about 50%.

on 160 meters is 53.5°. Calculate the surge impedance of the short vertical using Eq 9-14:

$$Z_{\text{surge}} = 60 \left[\ln \left(\frac{4 \times 2400}{25} \right) - 1 \right] = 297 \Omega$$

3.6.1.1. Calculate the loading coil

The capacitive reactance of a short vertical is:

$$X_C = \frac{Z_{\text{surge}}}{\tan t} \quad (\text{Eq 9-16})$$

where t = the electrical length of the vertical in degrees (24 meters is 53.5°).

$$\text{In this example, } X_C = \frac{297 \Omega}{\tan 53.5^\circ} = 220 \Omega$$

Since X_L must equal X_C ,

$$L = \frac{X_L}{2\pi \times f} = \frac{220}{2\pi \times 1.83} = 19.1 \mu\text{H}$$

Let us assume a Q factor of 300, which is easily achievable:

$$R_{\text{loss}} = \frac{X_L}{Q} = \frac{220 \Omega}{300} = 0.73 \Omega$$

This value of loss resistance is reasonably low, especially when you compare it with the value of R_{rad} calculated using Eq 9-7:

$$R_{\text{rad}} = 36.6 \times \frac{(1 - \cos 53.5^\circ)^2}{\sin^2 53.5^\circ} = 9.3 \Omega$$

ELNEC also calculates R_{rad} as 9.3 Ω. The radiation resistance is effectively in series with the ground-loss resistance. Assuming 60 λ/8 radials over good ground, the estimated equivalent loss resistance is about 10 Ω, meaning the feed-point impedance will be approximately 20 Ω. The efficiency will be 50%. The quality of the ground system (its equivalent loss resistance, see Table 9-1) determines the antenna efficiency much more than the loading device.

3.6.2. Capacitance-hat loading

Consider the design of a 30-meter vertical that will be loaded with a capacitance hat to resonate on 1.83 MHz. The electrical length of the 30-meter vertical is 67°. We must replace the missing 23° of electrical height with a capacitance hat (**Fig 9-52**).

First we calculate the surge impedance of the short vertical using Eq 9-14, assuming that the vertical's diameter is 25 cm. The surge impedance is:

$$Z_{\text{surge}} = 60 \left[\ln \left(\frac{4 \times 3000}{25} \right) - 1 \right] = 310 \Omega$$

Notice that the conductor diameter has a great influence

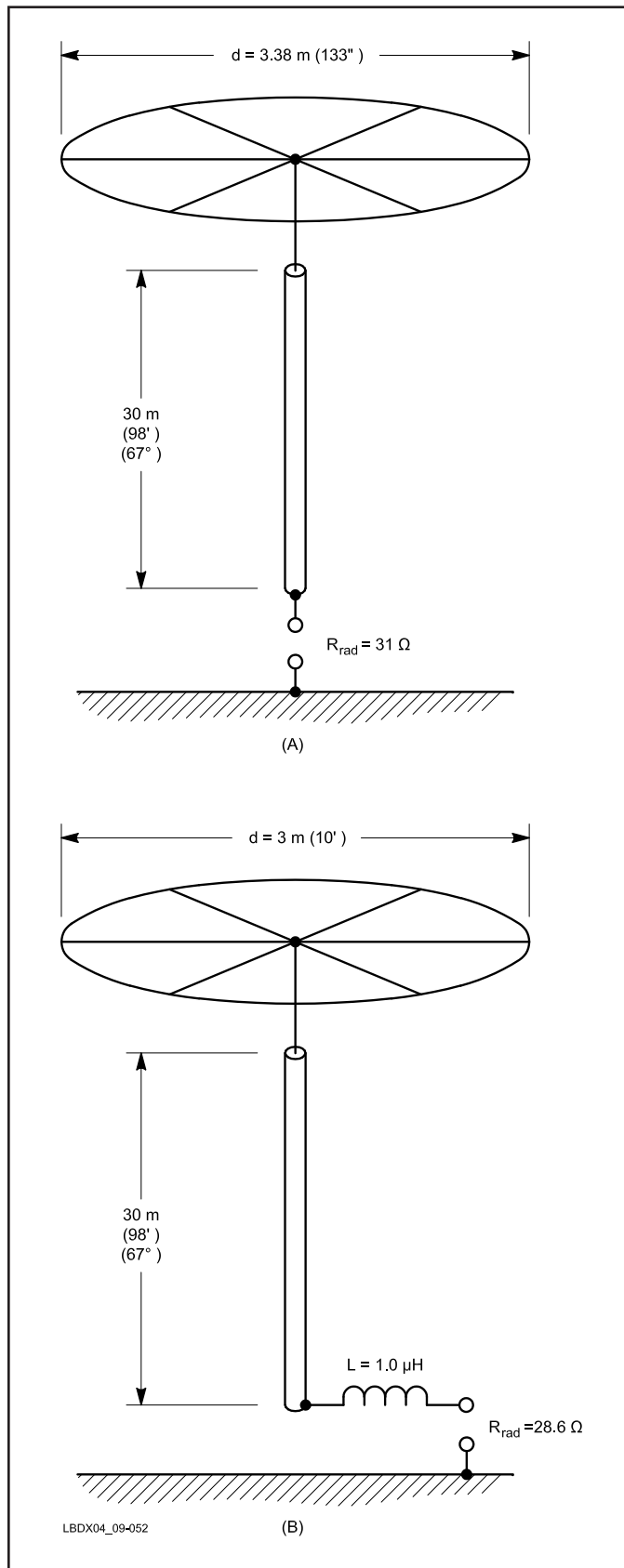

Fig 9-52—Examples of 160-meter verticals using capacitance hats. At A, the hat is dimensioned to tune the vertical to resonance at 1830 kHz. The antenna at B uses a capacitance hat of a given dimension, and resonance is achieved by using a small amount of base loading.

on the surge impedance. The same vertical made of 5-cm tubing would have a surge impedance of 407 Ω.

The electrical length of the capacitance top-hat is calculated:

$$X_C = \frac{Z_{\text{surge}}}{\tan t} \quad (\text{Eq 9-17})$$

where

$$\begin{aligned} X_C &= \text{reactance of the capacitance hat } (\Omega) \\ t &= \text{electrical length of the top hat} = 23^\circ \\ Z_{\text{surge}} &= 310 \Omega \end{aligned}$$

Eq 9-17 has the same form as Eq 9-15, but the definitions of terms are different.

$$X_C = \frac{310 \Omega}{\tan 23^\circ} = 730 \Omega$$

$$C_{\text{pF}} = \frac{10^6}{2\pi \times f \times X_C} = \frac{10^6}{2\pi \times 1.82 \times 730} = 119 \text{ pF}$$

3.6.2.1. Capacity of a disk:

The approximate capacitance of a solid-disk-shaped capacitive loading device is given by (Ref 7818):

$$C = 35.4 \times D \quad (\text{if } D < h/2) \quad (\text{Eq 9-18})$$

where

$$\begin{aligned} C &= \text{hat capacitance (in pF)} \\ D &= \text{hat diameter (in meters)} \\ h &= \text{height of disk above ground (in meters)} \end{aligned}$$

The capacitance of a solid disk can be achieved by using a disk in the shape of a wheel, having eight (large diameter) to 12 (small diameter) radial wires (Ref 7818). The capacitance of a single horizontal wire, used as a capacitive loading device is given by (Ref 7818):

$$C = k \times L \quad (\text{Eq 9-19})$$

where

$$\begin{aligned} k &= 10 \text{ pF/m for thick conductors } (L/d < 200) \\ k &= 6 \text{ pF/m for thin conductors } (L/d > 3000) \\ C &= \text{hat capacitance (in pF)} \\ L &= \text{length of wire (in meters)} \end{aligned}$$

3.6.2.2. Capacity of loading wires

If two loading wires are used at right angles to the vertical, the k-factors become approximately 8 pF/meter for thick conductors and 5 pF/meter for thin conductors. If the loading wires are not horizontal, they must be longer to achieve the same capacitive loading effect.

The capacitance of a sloping wire is given by:

$$C_{\text{slope}} = C_{\text{horizontal}} \times \cos \alpha \quad (\text{Eq 9-20})$$

where

$$\begin{aligned} C_{\text{horizontal}} &= \text{capacity of the horizontal wire} \\ \alpha &= \text{slope angle (with a horizontal wire } \alpha = 0^\circ) \end{aligned}$$

The required diameter of the disk need to achieve the 119 pF top-loading capacity is:

$$D = \frac{119}{35.4} = 3.4 \text{ meters}$$

Using a wire, the total required length of the (thin) wire is:

$$L = \frac{119}{6} = 19.8 \text{ meters}$$

This wire can be in the shape of a single horizontal or gently sloping wire; it can be the total length of the two legs of a T-shaped loading wire (horizontal or slightly sloping), or it can be the total length of four wires as shown in Fig 9-53.

The disk of a capacitance hat has a large screening effect to whatever is located above the disk. If there is a whip above a large disk, the lengthening effect of the whip may be largely undone. The same effect exists with towers loaded with Yagis. It is mainly the largest Yagi that determines the capacitance to ground. The capacitance hat in effect makes one plate of a capacitor with air dielectric; the ground is the other plate.

3.6.3. Capacitance hat with base loading

Consider the design of the same 30-meter vertical with a 3-meter diameter solid-disk capacitance hat for 1.83 MHz as shown in Fig 9-52B. The effective diameter of the vertical is again 25 cm. We know that this hat will be slightly too small to achieve resonance at 1.83 MHz. We will add some base loading to tune out the remaining capacitive reactance at the base of the vertical. This can be referred to as *fine tuning* the antenna. The coil will normally merge with the coil of an L network that might be used to match the vertical to the feed line.

The capacitance of a solid-disk hat is given by Eq 9-18: $C = 35.4 \times D$

In this example, $C = 35.4 \times 3 = 106 \text{ pF}$. The capacitive reactance of the hat at 1.83 MHz is:

$$\frac{10^6}{2\pi \times 1.83 \times 85} = 820 \Omega$$

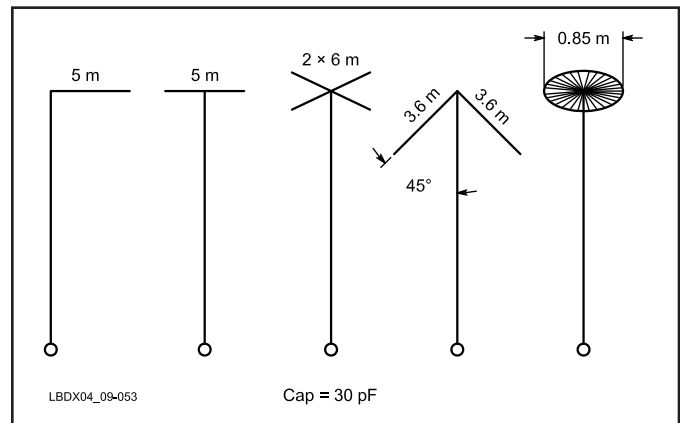

Fig 9-53—Capacitance hats can have various shapes, such as a disk, one or two wires, forming an inverted L or a T with the vertical. The lengths indicated are approximate values for a capacity of 30 pF.

Next we calculate the surge impedance:

$$Z_{\text{surge}} = 60 \left[\ln \left(\frac{4 \times 3000}{25} \right) - 1 \right] = 310 \Omega$$

The electrical length of the capacitance top-hat is calculated using Eq 9-17, rewritten as:

$$\tan t = \frac{Z_{\text{surge}}}{X_C} \text{ or } t = \arctan \left(\frac{Z_{\text{surge}}}{X_C} \right)$$

$$t = \arctan \left(\frac{310}{820} \right) = 20.7^\circ$$

For a thinner radiator, the electrical length of the hat would be higher, since Z_{surge} would be larger. The electrical length of our example vertical radiator is 67° , and the top-hat capacitance is 20.7° . Since the sum of the two is 87.7° , another 2.3° of loading is required to make a full 90° . Let us calculate the required loading coil for mounting at the base of the short vertical.

We must first calculate the surge impedance of the vertical with its capacitance top hat. The surge impedance was calculated above as 310Ω . The capacitive reactance is calculated using Eq 9-16:

$$X_C = \frac{Z_{\text{surge}}}{\tan t} = \frac{310 \Omega}{\tan 87.7^\circ} = 12.4 \Omega$$

Since X_L must equal X_C :

$$L = \frac{X_L}{2\pi \times F} = \frac{12.4}{2\pi \times 1.83} = 1.1 \mu\text{H}$$

The coil can be calculated using the program module available in the NEW LOW BAND SOFTWARE. Let's see what the equivalent series loss resistance of the coil will be to assess how the base-loading coil influences the radiation efficiency of the system. We will assume a coil Q of 300. Using Eq 9-12 we calculate:

$$R_{\text{loss}} = \frac{X_L}{Q} = \frac{12 \Omega}{300} = 0.04 \Omega$$

This negligible loss resistance is effectively in series with the ground-loss resistance. Calculate the radiation resistance using Eq 9-11:

$$\begin{aligned} R_{\text{loss}} &= 36.6 \frac{(\sin t_1 - \sin t_2)^2}{\cos^2 t_2} \\ &= 36.6 \frac{(\sin 67^\circ - \sin 2.3^\circ)^2}{\cos^2 2.3^\circ} \\ &= 28.4 \Omega \end{aligned}$$

With an equivalent ground resistance of 10Ω , the efficiency of this system (Eq 9-4) is:

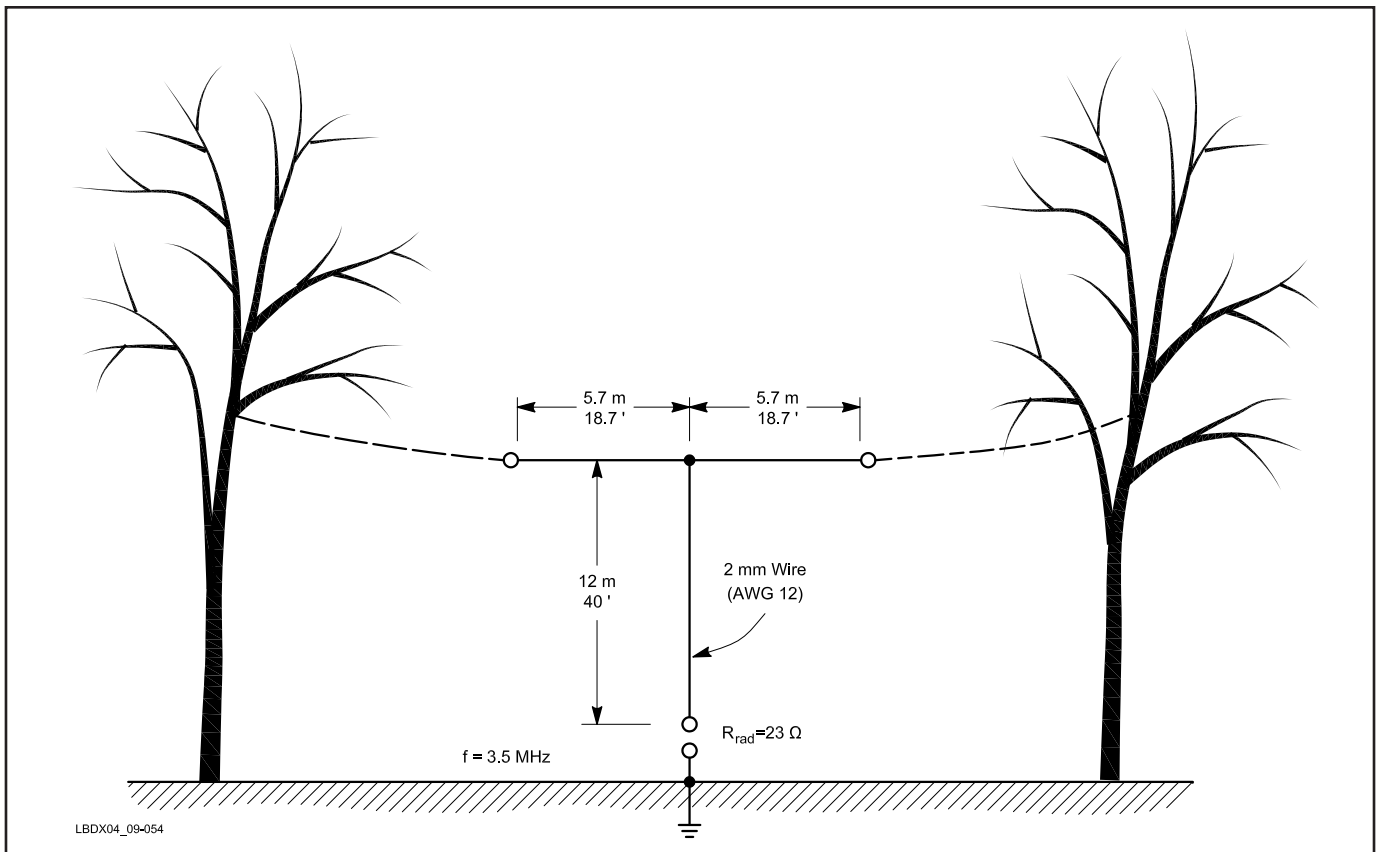

Fig 9-54—Typical setup of a current-fed T antenna for the low bands. Good-quality insulators should be used at both ends of the horizontal wire, as high voltages are present.

$$\text{Eff} = \frac{R_{\text{rad}}}{R_{\text{rad}} + R_{\text{loss}}} = \frac{28.4}{28.4 + 10 + 0.04} = 74\%$$

3.6.4. T-wire loading

If the vertical is attached at the center of the top-loading wire, the horizontal (high-angle) radiation from this top wire will be effectively canceled in the far field. The capacitance of a top-loading wire of small diameter is about 6 pF/meter for horizontal wires (see Chapter 8, Section 2.3.5). The total T-wire length is roughly twice the length of the missing portion of the vertical needed to make it into a $\lambda/4$ antenna.

Fig 9-54 shows a typical configuration of a T antenna. Two existing supports, such as trees, are used to hold the flattop wire. Try to keep the vertical wire as far as possible away from the supports, since power will inevitably be lost in the supports if close coupling exists.

Fig 9-55 shows a design chart derived using the *ELNEC* modeling program. The dimensions can easily be extrapolated to other design frequencies. In practice, the T-shaped loading wires will often be downward-sloping loading wires. In this case the radiation resistance will be slightly lower due to the vertical component from the downward-sloping current being in opposition with the current in the short vertical. Sloping loading wires will also be longer than horizontal ones, to achieve the same capacity (see Section 3.6.2.2 and Eq 9-20).

3.6.5. Capacitance hat plus coil

Often it will not be possible to achieve enough capacitance hat loading with practical structures, so additional coil loading may be required. If the hat is large enough to dwarf the distributed capacitance of the vertical, you can place a high-Q loading coil anywhere in the vertical and efficiency will remain essentially unchanged.

Let's work out an example of a 1.8-MHz antenna using a 12-meter mast, 5-cm OD, with a 1.2-meter diameter capacitance hat above the loading coil (Fig 9-56). The electrical length of the mast is 26.3° and the capacitance of the top hat, by rearranging Eq 9-18, is:

$$C = 35.4 \times D = 35.4 \times 1.2 = 42.5 \text{ pF}$$

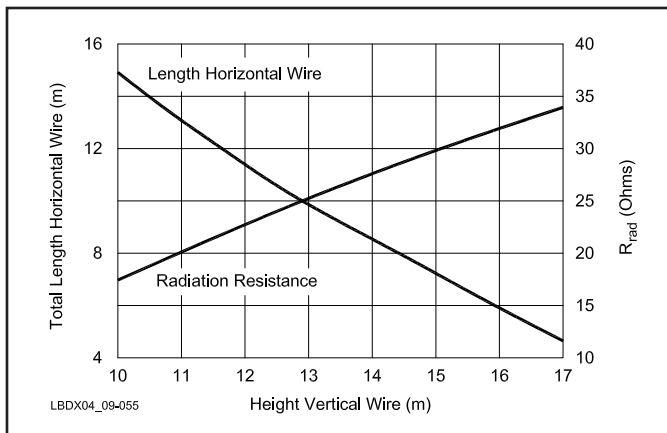

Fig 9-55—Design chart for a wire-type $\lambda/4$ current-fed T antenna made of 2-mm OD wire (AWG #12) for a design frequency of 3.5 MHz. For 160 meters the dimension should be multiplied by a factor of 1.9.

$$X_C = \frac{10^6}{2\pi \times 1.8 \times 42.5} = 2080 \Omega$$

The surge impedance of the vertical mast is calculated using Eq 9-14:

$$Z_{\text{surge}} = 60 \left[\ln \left(\frac{4 \times 1200}{5} \right) - 1 \right] = 352 \Omega$$

Let us analyze the vertical as a short-circuited transmission line with a characteristic impedance of 352 Ω . The input impedance of the short-circuited transmission line is given by:

$$Z = X_L = +j Z_0 \tan t \quad (\text{Eq 9-21})$$

where

- Z = input impedance of short-circuited line
- Z_0 = characteristic impedance of the line (352 Ω)
- t = line length in degrees

$$\text{Thus, } Z = +j 352 \times \tan (26.3^\circ) = +j 174 \Omega.$$

This means that the mast, as seen from above, has an inductive reactance of 174 Ω at the top. The capacitive reactance from the top hat is 2080 Ω . The loading coil, installed at the top of the mast, must have an inductive reactance of $2080 - 174 \Omega = 1906 \Omega$.

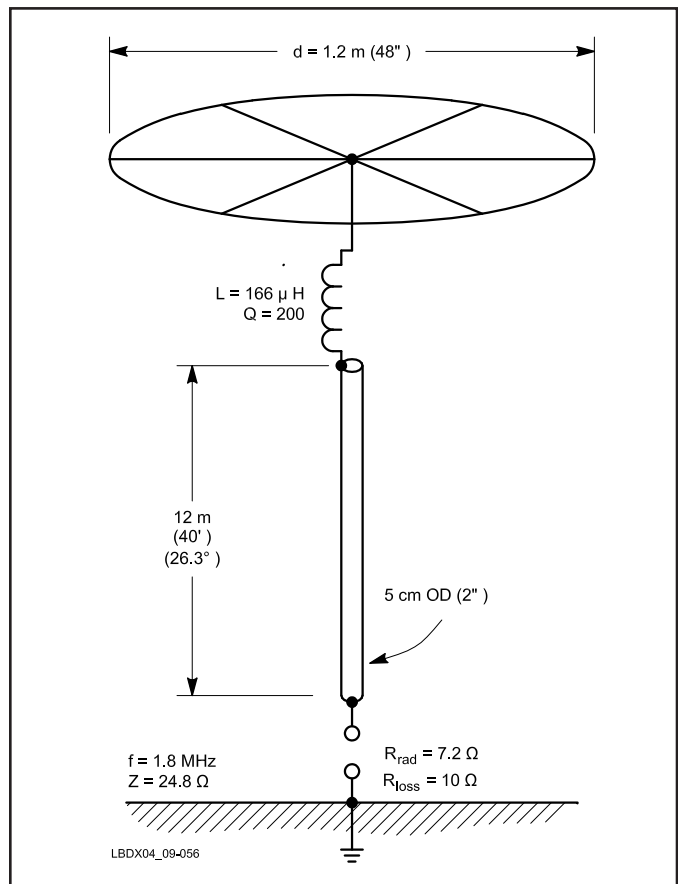

Fig 9-56—Top-loaded vertical for 160 meters, using a combination of a capacitance hat and a loading coil. See text for details.

$$L = \frac{1906}{2\pi \times 1.8} = 169 \mu\text{H}$$

Assuming you build a loading coil of such a high value with a Q of 200, the equivalent series loss resistance is:

$$R_{\text{loss}} = \frac{1906 \Omega}{200} = 9.5 \Omega$$

Using Eq 9-7, calculate the radiation resistance of the 12-meter long top-loaded vertical:

$$R_{\text{rad}} = 36.6 \times \sin^2 26.3^\circ = 7.2 \Omega$$

Notice that if you want to use the loss resistance of the (top) loading coil for determining the efficiency (or the feed-point impedance) of the vertical, you must transpose the loss resistance to the base of the vertical. This can be done by multiplying the loss resistance of the coil times the square of the cosine of the height of the coil. In our example the loss resistance transposed to the base is:

$$\text{Loss}_{\text{base}} = \text{Loss}_{\text{coil}} \times \cos^2 h = 9.5 \times \cos^2 26.3^\circ = 7.6 \Omega \quad (\text{Eq 9-22})$$

Assuming a ground loss of 10 Ω , the efficiency of the antenna is:

$$\text{Eff} = \frac{7.6}{7.6 + 10 + 7.4} = 29\%$$

If there were no coil loss, the efficiency would be 42%. This brings us to the point of power-handling capability of the loading coil.

3.6.5.1. Power dissipation of the loading coil

Let us determine how much power is dissipated in the loading coil, calculated as in Section 3.6.6 for an input power to the antenna of 1500 W. The base feed impedance is the sum of R_{rad} , R_{ground} and R_{coil} . The sum is $7.2 + 10 + 7.6 = 24.8 \Omega$.

The base current is:

$$I_{\text{base}} = \sqrt{\frac{1500}{24.8}} = 7.8 \text{ A}$$

The resistance loss of the loading coil is 7.6 Ω . The current at the position of the coil (26.3° above the feed point) is:

$$I_{\text{coil}} = 7.8 \times \cos 26.3^\circ = 7 \text{ A}$$

The power dissipated in the coil is: $I_{\text{coil}}^2 \times R_{\text{coil}} = 7.0^2 \times 9.5 = 465 \text{ W}$. This is an extremely high figure, and it is unlikely that we can construct a coil that will be able to dissipate this amount of power without failing (melting!). In practice, we will have to do one of the following things if we want the loading coil to survive:

- Run lower power. For 100 W of RF, the power dissipated in the coil is 31 W; for 200 W it is 62 W; for 400 W it is 124 W. Let us assume that 150 W is the amount of power that can safely be dissipated in a well-made, large-size coil. A maximum input power of 482 W can thus be applied to the vertical, where the assumed coil Q is 200.
- Use a coil of lower inductance and use more capacitive loading (with a larger hat or longer T wires). To allow a

power input of 1500 W, and assuming a ground loss of 10 Ω and a coil Q of 200, the maximum value of the loading coil for 150-W dissipation is 42.1 μH . This value is verified as follows (the intermediate results printed here are rounded):

The reactance of the coil is $= 2 \times \pi \times 1.8 \times 42.1 = 476 \Omega$.

The R_{loss} of the coil is $\frac{476 \Omega}{200} = 2.4 \Omega$.

Transposed to the base, $R_{\text{loss}} = 2.4 \times \cos^2 (26.3^\circ) = 1.9 \Omega$.

$$I_{\text{base}} = \sqrt{\frac{1500}{7.2 + 1 + 1.9}} = 12.2 \text{ A}$$

This current, transposed to the coil position, is $8.9 \times \cos 26.3^\circ = 7.9 \text{ A}$.

$$P_{\text{coil}} = 7.9^2 \times 2.4 = 150 \text{ W}.$$

This is only about 20% of the value of the original 168- μH inductance needed to resonate the antenna at 1.8 MHz. This smaller coil will require a substantially larger capacitance hat to resonate the antenna on 160 meters. T wires would also be a good way to tune the antenna to resonance.

- Make a coil with the largest possible Q. If we change the coil with a Q of 200 in the above example to 300 and run 1500 W, then the maximum coil inductance is 63.1 μH . The calculation procedure is identical to the above example.

The reactance of the coil is $= 2 \times \pi \times 1.8 \times 63.1 = 714 \Omega$.

The R_{loss} of the coil is $714/300 = 2.4 \Omega$.

Transposed to the base, $= 2.4 \times \cos^2 (26.3^\circ) = 1.9 \Omega$

$$I_{\text{base}} = \sqrt{\frac{1500}{7.2 + 10 + 1.9}} = 8.9 \text{ A}$$

This current, transposed to the coil position, is $8.9 \times \cos 26.3^\circ = 7.9 \text{ A}$.

$$P_{\text{coil}} = 7.9^2 \times 2.4 = 150 \text{ W}.$$

This means that an increase of Q from 200 to 300 allows us to use a loading coil of 63.1 μH instead of 42.1 μH , resulting in the same power being dissipated in the coil. As you can see, the inductance needed is inversely proportional to the Q for a constant power dissipation in the coil.

Notice that the ground-loss resistance again has a great influence on the power dissipated in the loading coil. Staying with the same example as above (Q = 300, L = 63.1 μH), the power loss in the coil for a ground-loss resistance of 1.0 Ω (an excellent ground system) is:

$$I_{\text{base}} = \sqrt{\frac{1500}{7.2 + 1 + 1.9}} = 12.2 \text{ A}$$

$$P_{\text{coil}} = (12.2 \times \cos 26.3^\circ)^2 \times 2.4 = 284 \text{ W}.$$

The better the ground system, the more power will be dissipated in the loading coil. C. J. Michaels, W7XC, investigated the construction and the behavior of loading coils for 160 meters (Ref 797). In the above examples we assumed Q factors of 200 and 300. (See also Ref 694 and 695.) How can

we build loading coils having the highest possible unloaded Q? Michaels came to the following conclusions:

- For coils with air dielectric, the L/D (length/diameter) ratio should not exceed 2:1.
- For coils wound on a coil form, this L/D ratio should be 1:1.
- Long, small-diameter coils are not good.
- The highest Q that can be achieved for a 150- μH loading coil for 160 meters is approximately 800. This can be achieved with an air-wound coil (15-cm long by 15-cm diameter), using 35 turns of AWG #7 (3.7-mm diameter) wire, or with an air-wound coil (30-cm long by 15-cm diameter, wound with 55 turns of AWG #4 (5.1-mm diameter) wire.
- Coil diameters of 10 cm wound with AWG #10 to #14 wire can yield Q factors of 600, while coil diameters of 5 cm wound with BSWG #20 to #22 will not yield Q factors higher than approximately 250. These smaller wire gauges should not be used for high-power applications.

You can use some common sense and simple test methods for selecting an acceptable plastic coil-form material:

- High-temperature strength: Boil a sample for $\frac{1}{2}$ hour in water, and check its rigidity immediately after boiling while still hot.
- Check the loss of the material by inserting a piece inside an air-wound coil, for which the Q is being measured. There should be little or no change in Q.
- Check water absorption of the material: Soak the sample for 24 hours in water and repeat the above test. There

should be no change in Q.

- Dissipation factor: Put a sample of the material in a microwave oven, together with a cup of water to load the oven. Run the oven until the water boils. The sample should not get appreciably warm.

3.6.6. Coil with T wire

A coil with T-wire configuration at the top of the vertical is essentially the same as the one just described in Section 3.6.5. For a capacitance hat we would normally adjust the resonant frequency by pruning the value of the loading coil or by adding some reactance (inductor for positive or capacitor for negative) at the base of the antenna. For a T-loading wire system it is easier to tune the vertical to resonance by adjusting the length of the T wire.

You can also fine tune by changing the “slope” angle of the T wires. If the T wires are sloped downward the resonant frequency goes up, but also the radiation resistance will drop somewhat. Fig 9-57 shows two examples of practical designs. For the guyed vertical shown in Fig 9-57B, changing the slope angle by dropping the wires from 68° (ends of T wires at 12-meter height) to 43° (ends at 9-meter height) raises the resonant frequency of the antenna from 1.835 kHz to 1.860 kHz. Note, though, that with this change the radiation resistance drops from 10.1Ω to 8.3Ω .

The larger the value of the coil, the lower the efficiency will be, as we found previously. The equivalent loss resistance

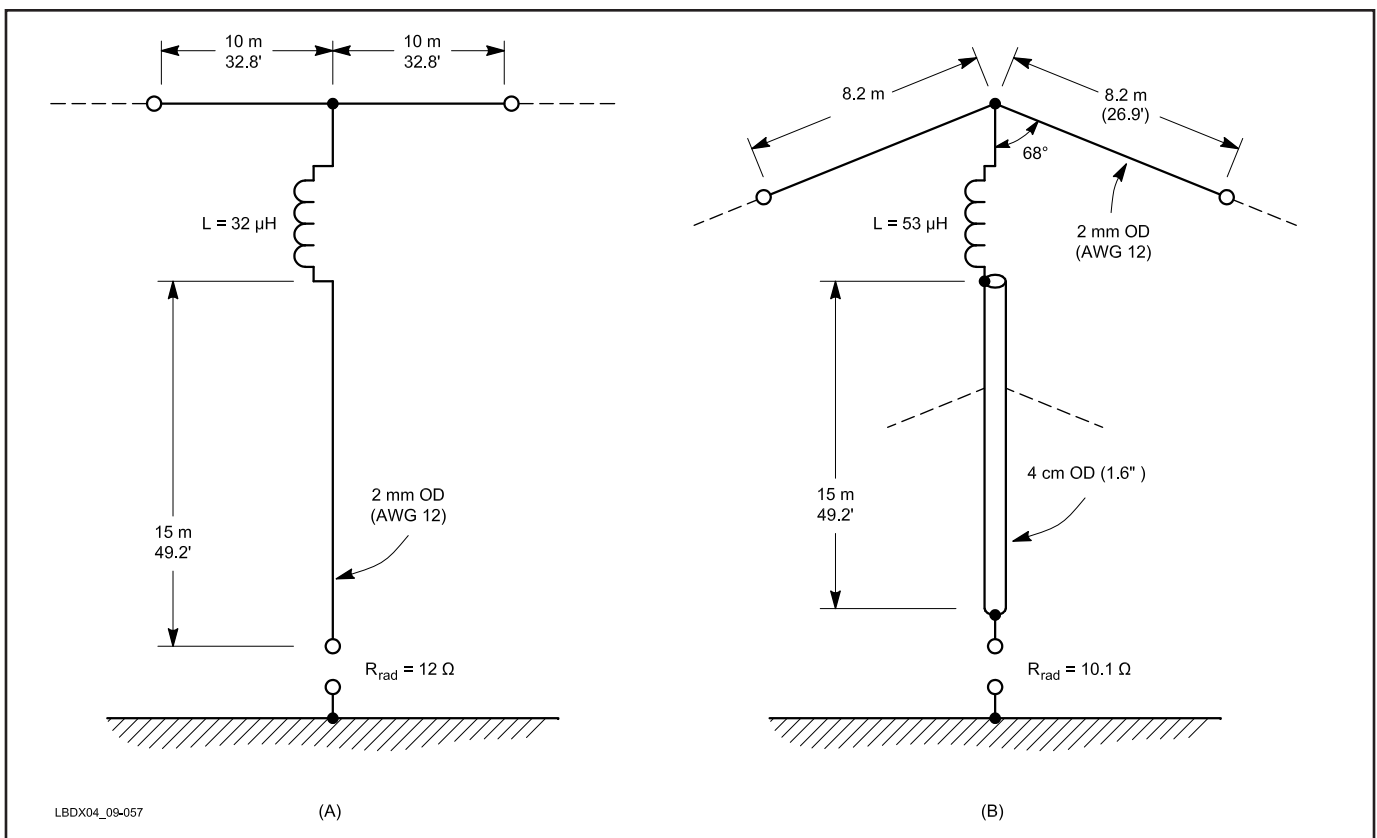

Fig 9-57—Practical examples of combined coil and flat-top wire loading. At A, a wire antenna with a loading coil at the top of the vertical section (no space for longer top-load wires). At B, a loaded vertical mast (4-cm OD) where two of the top guy wires, together with a loading coil, resonate the antenna at 1.835 MHz. The remaining guy wires are made of insulating material (eg, Kevlar, Phillystran, etc).

of the coil and the transposed loss resistance required to determine the efficiency and the feed impedance of the vertical can be calculated as shown in Section 3.6.5. Again, you should avoid having a coil of more than 75 μH of inductance.

3.6.7. Coil with whip

Now we consider a vertical antenna loaded with a whip and a loading coil, as shown in **Fig 9-58**. Let's work out an example for 160 meters:

- Mast length below the coil = 18.16 meters = 40°
- Mast length above the coil (whip) = 4.54 meters = 10°
- Design frequency = 1.835 MHz
- Mast diameter = 5 cm
- Whip diameter = 2 cm

Calculate the surge impedance of the bottom mast section using Eq 9-14:

$$Z_{\text{surge}} = 60 \left[\ln \left(\frac{4 \times 1816}{5} \right) - 1 \right] = 377 \Omega$$

Looking at the base section as a short-circuited line with an impedance of 377 Ω , we can calculate the reactance at the top of the base section using Eq 9-17 rearranged:

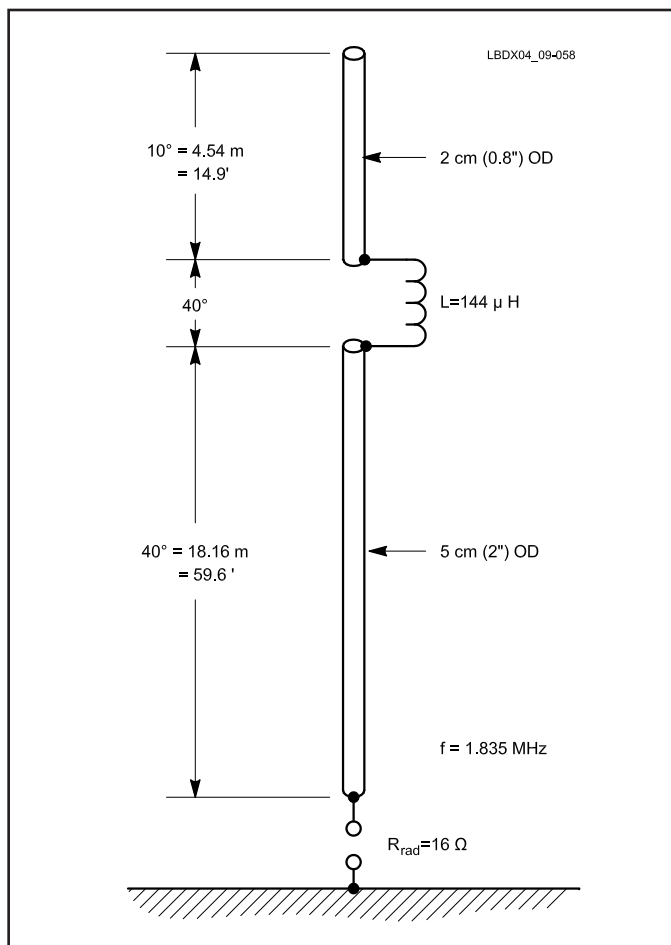

Fig 9-58—Practical example of a vertical loaded with a coil and whip. The length and diameter of the whip are kept within reasonable dimensions that can be realized on top of a loading coil without guying.

$$Z = X_L = +j 377 \times \tan 40^\circ = +j 316 \Omega$$

Calculate the surge impedance of the whip section, again using Eq 9-14:

$$Z_{\text{surge}} = 60 \left[\ln \left(\frac{4 \times 454}{2} \right) - 1 \right] = 349 \Omega$$

Let us look at the whip as an open-circuited line having a characteristic impedance of 349 Ω . The input impedance of the open-circuited transmission line is given by:

$$Z = X_C = -j \frac{Z_0}{\tan t} \quad (\text{Eq 9-23})$$

where

Z_0 = characteristic impedance (here = 349 Ω)

t = electrical length of whip (here = 10°)

The reactance of the whip is:

$$Z = X_C = -j \frac{349}{\tan 10^\circ} = -j 1979$$

Sum the reactances:

$$X_{\text{tot}} = +j 316 \Omega - j 1979 \Omega = -j 1663 \Omega$$

This reactance is tuned out with a coil having a reactance of +j 1663 Ω :

$$L = \frac{X_L}{2\pi \times f} = \frac{1663}{2\pi \times 1.835} = 144 \mu\text{H}$$

Assuming you build the loading coil with a Q of 300, the equivalent series loss resistance is

$$R_{\text{loss}} = X_L/Q = 1663/300 = 5.5 \Omega.$$

The coil is placed at a height of 40° . Transpose this 5.5- Ω loss to the base using Eq 9-22:

$$R_{\text{loss@base}} = 5.5 \Omega \times \cos^2(40^\circ) = 3.2 \Omega$$

Calculate the radiation resistance using Eq 9-10:

$$R_{\text{rad}} = 36.6 \times (1 - \sin^2 80^\circ + \sin^2 40^\circ)^2 = 16 \Omega$$

Assuming a ground resistance of 10 Ω , the efficiency of this antenna is:

$$\text{Eff} = \frac{16}{16 + 10} = 55\%$$

I modeled the same configuration using *ELNEC* and found the following results:

Required coil = 1650 Ω reactance = 143 μH

$$R_{\text{rad}} = 20 \Omega$$

The R_{rad} is 25% higher than what we found using Eq 9-10. This formula uses a few assumptions, such as equal diameters for the mast section above and below the coil, which is not the case in our design. This is probably the reason for the difference in R_{rad} .

3.6.8. Sloping loading wires

Using top loading in the shape of a number of wires

radially extending from the top of the vertical is, together with the disk solution, by far the most efficient way to load a short vertical. Often though, we slope these wires down at an angle, lacking suitable supports to erect them horizontally. In this configuration the radiation resistance will be lower due to the vertical component from the downward-sloping current being in opposition with the current in the short vertical. Sloping loading wires must also be longer than horizontal ones to achieve the same capacity (see Section 3.6.3 and Eq 9-18). The reduction in R_{rad} results in an inevitable reduction in efficiency, given the same ground loss resistance. With a lossless ground (such as saltwater), there is no reduction in efficiency.

Mauri, I4JMY published on the Topband reflector some modeling results using a 9-meter long vertical with four 20-meter long top hat wires. He calculated the efficiency, assuming a ground loss resistance of 5 Ω , which is for a fairly elaborate ground system (see Table 9-1).

- Horizontal hat wires: $R_{\text{rad}} = 5.5 \Omega$; $Z_{\text{feed}} = 10.5 \Omega$; Eff = 48% , Ref = 0 dB
- Hat wires sloping down to 4.5 meters: $R_{\text{rad}} = 3.2 \Omega$; $Z_{\text{feed}} = 8.2 \Omega$, Eff = 39%, -1.8 dB
- Hat wires sloping down to 1.5 meters: $R_{\text{rad}} = 2.0 \Omega$; $Z_{\text{feed}} = 7 \Omega$, Eff = 28%, -4.7 dB
- Hat wires sloping down to 0.3 meters : $R_{\text{rad}} = 1.6 \Omega$; $Z_{\text{feed}} = 6.6 \Omega$, Eff = 24%, -6 dB

If you were using the same vertical with a base-loading coil (see procedure in Section 3.6.1.), you would have $R_{\text{rad}} = 1.2 \Omega$, required loading coil reactance $\sim 900 \Omega$, which, assuming a Q of 300, means a coil loss resistance of 3 Ω . Total efficiency of this setup (assuming the same 5 Ω ground loss) is $1.2/(1.2+3+5) = 13\%$. From this perspective, even the last of the above solutions with four top hat wires sloping down almost to the ground has double the efficiency compared to base coil loading, or a relative gain of 3 dB! In addition, the sloping-hat-wire solution presents a higher feed resistance, which makes it somewhat easier to match with low losses.

Mauri rightfully adds *“I’d keep the ends of the sloping hat wires as high as I could. I would also keep the antenna impedance slightly capacitive using a smaller hat than required. This I’d do in order to use a coil at the antenna base that would serve both to resonate the antenna and to act as a step-up autotransformer.”* (This is shown in Fig 9-45.) You should not forget either that the solution with the sloping hat wires has considerably more bandwidth than when using a large loading coil.

How steep a slope angle can be tolerated? Preferably not more than approximately 45°. Four top hat wires sloping at a 45° angle reduce R_{rad} to 50% already. Tom, W8JI, summed it all up nicely by saying: *“Any vertical you can build without a hat, I can build better with one.... even if I have to fold the hat down.”*

An important mechanical issue: Top hats on verticals must be pulled out as tight as possible. If not, they will blow around in the wind, or sag a lot with ice and your resonant point will blow and sag with them.

The same remarks on down-sloping top hat wires also apply to an inverted-L antenna. See Section 7.

3.6.9. Using modeling programs

In this section on short verticals I used equations for the transmission-line equivalent for an antenna. You can, of

course, obtain the same information by modeling these antennas with a modeling program such as *EZNEC*. In this age of antenna modeling, I thought it was a good idea to use simple math and trigonometry to understand the physics and to calculate the numbers.

3.6.10. Comparing different loading methods

To see how different loading methods work, let’s compare verticals of identical physical lengths over a relatively poor ground. Where you cannot erect a full-size vertical, you probably won’t be able to put down an elaborate radial system either, so we’ll use a rather high ground resistance in this comparative study. The study is based on the following assumptions:

- Physical antenna length = 45° ($\lambda/8$)
- L = 20.5 meters
- Design frequency = 1.83 MHz.
- Antenna diameter = 0.1° on 160 meters = 4.55 cm
- Ground-system loss resistance = 15 Ω .

Quarter-wave full size (reference values):

$R_{\text{rad}} = 36 \Omega$
 $R_{\text{ground}} = 15 \Omega$
 $R_{\text{ant loss}} = 0 \Omega$
 $Z_{\text{feed}} = 51 \Omega$
 Eff = 71%
 Loss = 1.5 dB

Base loading, $\lambda/8$ size:

$R_{\text{rad}} = 6.2 \Omega$
 $R_{\text{ground}} = 15 \Omega$
 Coil Q = 300
 $L_{\text{coil}} = 34 \mu\text{H}$
 $R_{\text{coil loss}} = 1.3 \Omega$
 $Z_{\text{feed}} = 22.5 \Omega$
 Eff = 28%
 Loss = 5.6 dB

Top-loaded vertical (capacitance hat or horizontal T wire, $\lambda/8$ size):

$R_{\text{rad}} = 18 \Omega$
 $R_{\text{ground}} = 15 \Omega$
 $Z_{\text{feed}} = 33 \Omega$
 Eff = 55%
 Loss = 2.6 dB

Top-loaded vertical (coil with capacitance hat at top, $\lambda/8$ size):

$R_{\text{rad}} = 18 \Omega$
 $R_{\text{ground}} = 15 \Omega$
 Diameter of capacitance hat = 3 meters
 $L_{\text{coil}} = 37 \mu\text{H}$
 Coil Q = 200
 $R_{\text{coil loss}} = 2.1 \Omega$
 $R_{\text{coil loss}}$ transposed to base = 1 Ω
 $Z_{\text{feed}} = 34 \Omega$
 Eff = 53%
 Loss = 2.8 dB

Top-loaded vertical (coil with whip, $\lambda/8$ size):

$R_{\text{rad}} = 12.7 \Omega$
 $R_{\text{ground}} = 15 \Omega$
 Length of whip = 10° (4.55 meters on 1.83 MHz)

$L_{\text{coil}} = 150 \mu\text{H}$
 Coil $Q = 200$
 $R_{\text{coil loss}} = 8.6 \Omega$
 $R_{\text{coil loss}}$ transposed to base = 5.8Ω
 $Z_{\text{feed}} = 33.5 \Omega$
 Eff = 38%
 Loss = 4.2 dB

3.6.11. Conclusions

With an average to poor ground system (15Ω), a $\lambda/8$ vertical with capacitance top loading is only 1.1 dB down from a full-size $\lambda/4$ vertical. Over a better ground the difference is even less. If possible, stay away from loading schemes that require a large coil.

4. TALL VERTICALS

In this section we'll examine verticals that are substantially longer than $\lambda/4$, especially their behavior over different types of ground. Is a very low elevation angle computed over ideal ground ever realized in practice?

First of all, you need to ask whether you really need very low elevation angles on the low bands. A very low incident angle grazes the ionosphere for a long distance increasing loss. More hops with less loss from a sharper angle can actually decrease propagation loss. We saw in Chapter 1 that relatively high launch angles are actually a prerequisite to allow a "duct" to work on 160 meters, typically at sunrise. On 160 meters, we can state that the antenna with the most gain at the lowest elevation angle under almost all circumstances will produce the strongest signal.

In this section I will dispel a myth that voltage-fed antennas do not require an elaborate ground system. In fact, long verticals require an even better radial system and an even better ground quality in the Fresnel zone to achieve their low-angle and gain potential compared to a $\lambda/4$ vertical.

In earlier sections of this chapter, I dealt with short verticals in detail, mostly for 160 meters. On higher frequencies, electrically taller verticals are quite feasible. A full-size $\lambda/4$ radiator on 80 meters is approximately 19.5 meters in height. Long verticals are considered to be $\lambda/2$ to $5\lambda/8$ in length. Verticals that are slightly longer than a quarter-wave (up to 0.35λ) do not fall in the *long vertical* category.

4.1. Vertical Radiation Angle

Fig 9-59 shows the vertical radiation patterns of two long verticals of different lengths. These are analyzed over an identical ground system consisting of average earth with 60 $\lambda/4$ radials. A $\lambda/4$ vertical is included for comparison.

Note that going from a $\lambda/4$ vertical to a $\lambda/2$ vertical drops the maximum-elevation angle from 26° to 21° . More important, however, is that the -3 -dB vertical beamwidth drops from 42° to 29° . Going to a $5\lambda/8$ vertical drops the elevation angle to 15° with a -3 -dB beamwidth of only 23° . But notice the high-angle lobe showing up with the $5\lambda/8$ vertical. If we make the vertical still longer, the low-angle lobe will disappear and be replaced by a higher-angle lobe. A $3\lambda/4$ vertical has a radiation angle of 45° .

Whatever the quality of the ground, the $5\lambda/8$ vertical will always produce a lower angle of radiation and also a narrower vertical beamwidth. The story gets more complicated, though, when you compare the efficiency of the antennas.

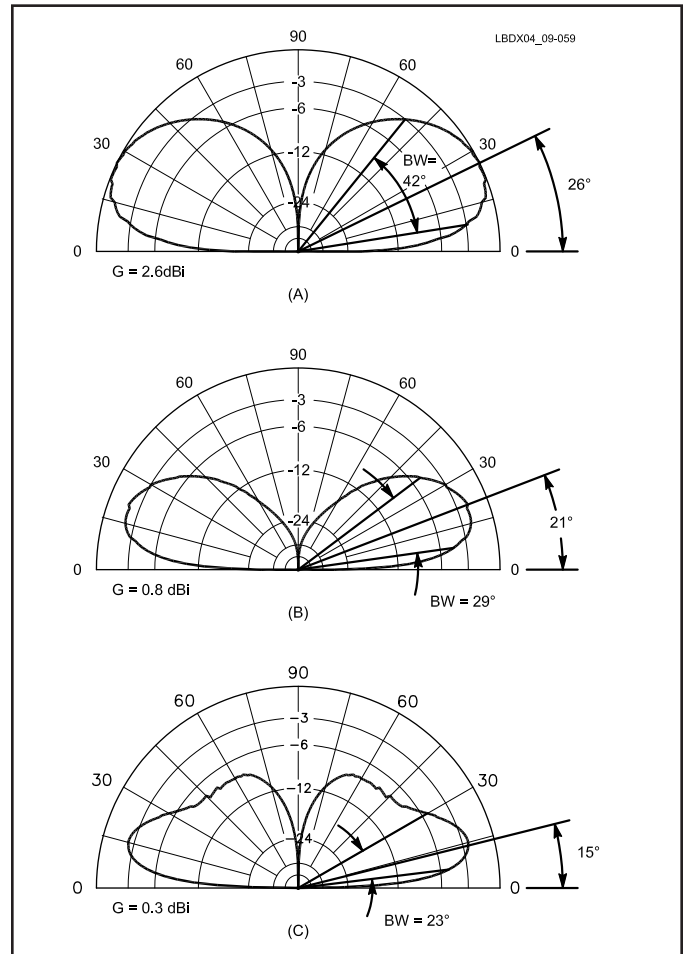

Fig 9-59—Vertical radiation patterns of different-length verticals over average ground, using 60 $\lambda/4$ radials. The 0-dB reference for all patterns is 2.6 dBi. At A, $\lambda/4$ vertical. At B, $\lambda/2$ and at C, $5\lambda/8$.

4.2. Gain

I have modeled both a $\lambda/4$ as well as a $5\lambda/8$ vertical over different types of ground, in each case using a realistic number of 60 $\lambda/4$ radials. Fig 9-5 shows the patterns and the gains in dBi for the quarter-wave vertical, and Fig 9-60 shows the results for the $5\lambda/8$ antenna.

Over perfect ground, the $5\lambda/8$ vertical has 3.0 dB more gain than the $\lambda/4$ vertical at a 0° elevation angle. Note the very narrow lobe width and the minor high-angle lobe (broken-line patterns in Fig 9-60).

Over saltwater the $5\lambda/8$ has lost 0.8 dB of its gain already; the $\lambda/4$ only 0.4 dB. The $5\lambda/8$ vertical has an extremely low elevation angle of 5° and a vertical beamwidth of only 17° . The $\lambda/4$ has an 8° take off angle, but a 40° vertical beamwidth.

Over very good ground, the $5\lambda/8$ vertical has now lost 5.0 dB; the $\lambda/4$ only 1.9 dB. The actual gain of the $\lambda/4$ in other words equals the gain of the $5\lambda/8$! Note also that the high-angle lobe of the $5\lambda/8$ becomes more predominant as the quality of the ground decreases.

Over average ground the situation becomes really poor for the $5\lambda/8$ vertical. The gain has dropped 7.3 dB, and the secondary high-angle lobe is only 4 dB down from the low-

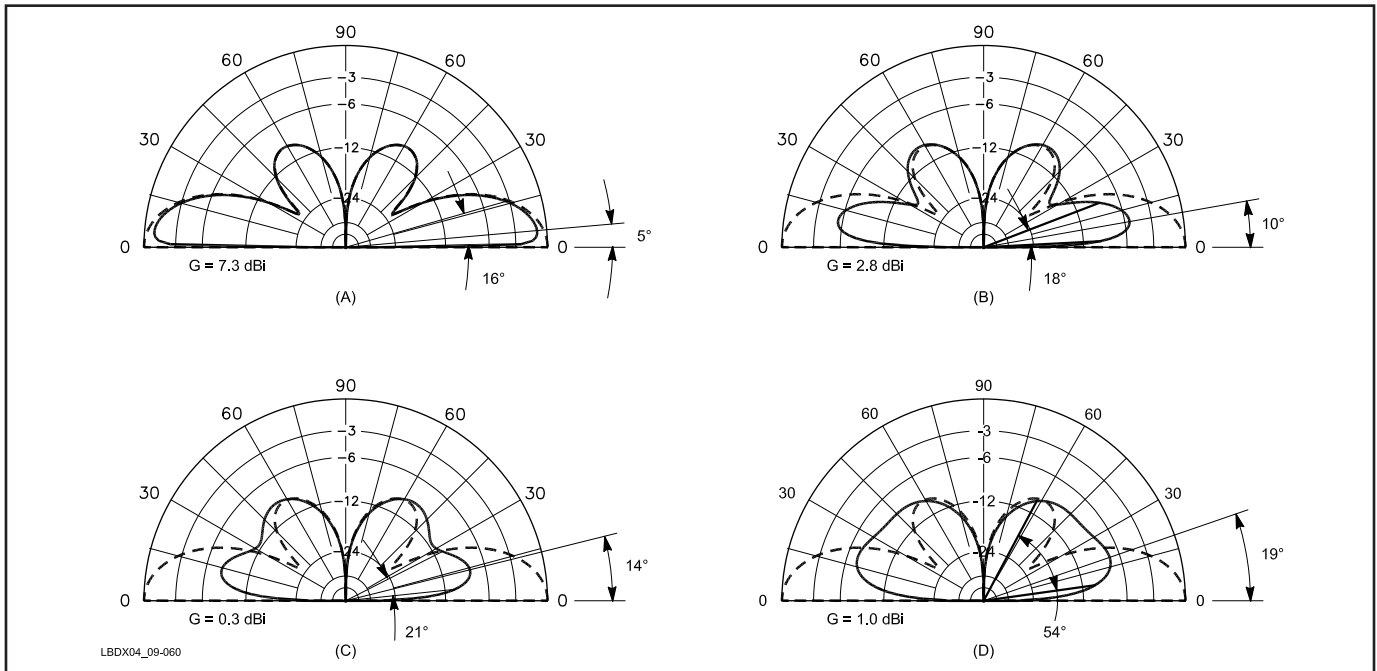

Fig 9-60—Vertical radiation pattern of the $5\lambda/8$ vertical over different types of ground. In all cases, $60 \lambda/4$ radials were used. The theoretical perfect-ground pattern is shown in each case as a reference (broken line, with a gain of 8.1 dBi). Compare with the patterns and gains of the $\lambda/4$ vertical, modeled under identical circumstances (Fig 9-5). At A, over saltwater. At B, over very good ground. At C, over average ground. At D, over very poor ground.

angle lobe. The $\lambda/4$ vertical has lost 2.6 dB versus ideal ground, and now shows 2.0 dB *more* gain than the $5\lambda/8$ vertical!

Over very poor ground the $5\lambda/8$ vertical has lost 6.6 dB from the perfect-ground situation, while the $\lambda/4$ vertical has lost only 3.0 dB. Note that the $5\lambda/8$ vertical seems to pick up some gain compared to the situation over average ground. From Fig 9-60 you can see this is because the radiation at lower angles is now attenuated so much that the radiation from the high-angle lobe at 60° becomes dominant. Note also that the level of the high-angle lobe hardly changes from the perfect-ground situation to the situation over very poor ground. This is because the reflection for this very high angle takes place right under the antenna, where the ground quality has been improved by the $60 \lambda/4$ radials.

This must come as a surprise to most. How can we explain this? An antenna that intrinsically produces a very low angle (at least in the perfect-ground model) relies on reflection at great distances from the antenna to produce its low-angle radiation. At these distances, radials of limited length do not play any role in improving the ground. With poor ground, a great deal of the power that is sent out at a very low angle to the ground-reflection point is being absorbed in the ground rather than being reflected (see also Section 1.1.2). For Fresnel-zone reflections the long vertical requires a better ground than the $\lambda/4$ vertical to realize its full potential as a low-angle radiator.

4.3. The Radial System for a Half-Wave Vertical

Here comes another surprise. A terrible misconception about voltage-fed verticals is that they do not require either a good ground or an extensive radial system.

4.3.1. The near field

If you measure the current going into the ground at the base of a $\lambda/2$ vertical, the current will be very low (theoretically zero). With $\lambda/4$ and shorter verticals, the current in the radials increases in value as you get closer to the base of the vertical. That's why, for a given amount of radial wire, it is better to use many short radials than just a few long ones.

With voltage-fed antennas, however, the earth current will increase as you move away from the vertical. Brown (Ref 7997) calculated that the highest current density exists at approximately 0.35λ from the base of the voltage-fed $\lambda/2$ vertical. Therefore it is even more important to have a good radial system with a voltage-fed antenna such as the voltage-fed T or a $\lambda/2$ vertical. These verticals require longer radials to do their job efficiently compared to current-fed verticals.

4.3.2. The far field

In the far field, the requirement for a good ground with a long vertical is much more important than for a $\lambda/4$ vertical. I have modeled the influence of the ground quality on the gain of a vertical by the following experiment.

- I compared three antennas: a $\lambda/4$ vertical, a voltage-fed $\lambda/4$ T (also called an inverted ground plane) and a $\lambda/2$ vertical.
- I modeled all three antennas over average ground.
- I put them in the center of a disk of perfectly conducting material and changed the diameter of the disk to determine the extent of the Fresnel zone for the three antennas.

The results of the experiment are shown in Fig 9-61. Let us analyze those results.

- With a conducting disk $\lambda/4$ in radius (equal to a large number of $\lambda/4$ radials) the $\lambda/4$ current-fed vertical is

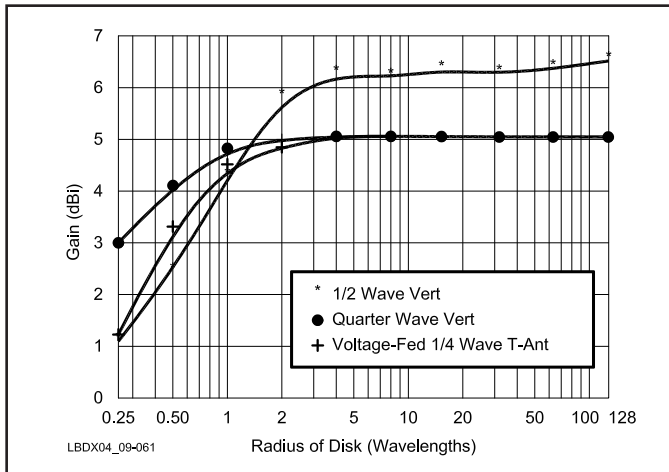

Fig 9-61—Gain of three types of verticals over a perfectly conducting disk of varying radius. The ground beyond the disk is of good quality. This means that the $\lambda/2$ vertical requires 0.6- λ radials to perform as well as the $\lambda/4$ vertical with $\lambda/4$ radials. Be aware that the radiation angle of the $\lambda/2$ vertical will be much lower, however.

almost 2 dB better than the voltage-fed $\lambda/4$ and the $\lambda/2$ vertical.

- The $\lambda/4$ vertical remains better than the other antennas up to a disk size of 1.5- λ diameter. This means that over good ground you must be able to put out radials at least 2- λ long with a $\lambda/2$ vertical before it shows any gain over the $\lambda/4$ current-fed vertical.
- The voltage-fed $\lambda/4$ vertical (voltage-fed T) equals the current-fed $\lambda/4$ for a disk size of at least 2 λ in diameter. This is because the current maximum is at the top of the antenna, which means that for a given elevation angle, the Fresnel zone (where the main wave hits the ground to be reflected) is much farther away from the base of the vertical than is the case with a $\lambda/4$ current-fed vertical. In other words, there is no advantage in using such a voltage-fed $\lambda/4$ antenna.
- For both the voltage and the current-fed $\lambda/4$ vertical, the Fresnel zone is situated up to 4 λ away from the vertical. For the $\lambda/2$ vertical, the Fresnel zone stretches out to some 100 λ !

4.4. In Practice

On 40 meters, a height more than $\lambda/4$ (10 meters) should be easy to install in most places. In many cases it will be the same vertical that is used as a $\lambda/4$ vertical on 80 meters.

I have been using a $5\lambda/8$ vertical for 40 meters for more than 20 years with good success. With Beverage receiving antennas it has always been a relatively good performer. Now that I have been using a 3-element Yagi at 30 meters for a few years, I know that the vertical solution was far from ideal.

Earl Cunningham, K6SE's, experience confirms this: "I used a grounded $1/2$ - λ vertical in the Houston/Gulf Coast area where the soil conductivity is abnormally high. It was a super performer. The same vertical here in the desert (Palmdale, CA) was a ho-hum performer, even with a much more extensive ground radial system."

A similar testimony comes from Tom Rauch, W8JI, who wrote: "...I had the same results using BC arrays on 160 meters. The 250-ft to 300-ft verticals stunk; my $1/4$ - λ vertical would beat them. I find the same effect on 80 meters."

Figs 9-9 and 9-12 give the base resistance, $R_{\text{Rad(B)}}$, and feed-point reactance for monopoles as a function of the conductor diameter in degrees, and in Figs 9-10 and 9-13 as a function of the antenna length-to-diameter ratio. The graphs are accurate only for structures with rather large diameters (not for single-wire structures) and that have uniform diameters. A conductor diameter of 1° equals 833/f (MHz) in mm.

5. MODELING VERTICAL ANTENNAS

ELNEC as well as other versions of *MININEC* are well suited to do your own vertical antenna modeling, as is the *NEC-2*-based *EZNEC* program. Be aware, however, that all *MININEC*-based antenna modeling programs assume a perfect ground under the antenna base for computing the impedance of the antenna. You cannot use these programs to assess the efficiency of the vertical, where I have defined efficiency as:

$$\text{Eff} = \frac{R_{\text{rad}}}{R_{\text{rad}} + R_{\text{loss}}}$$

MININEC will show the influence of the reflecting ground in the far field that creates the low-angle radiation pattern of the vertical antenna. If you want to include the losses of the ground, you can insert a resistance at the feed point, having a value equivalent to the assumed loss resistance of the ground (see Table 9-1).

5.1. Wires and Segments

In modeling terminology, a *wire* is a straight conductor and is part of the antenna. A *segment* is a part of a wire. Each wire can be broken up into a number of segments, usually all with the same length. Each segment has a different current. The more segments a wire has, the closer the current (pulse) distribution will come to the actual current distribution. There are limits, however.

- Many segments take a lot of computing time.
- Each segment should be at least 2.5 times the wire diameter (according to *MININEC* documentation).

There is no general rule about the minimum number of segments that should be used on a wire. There is only the cut-and-try rule, where you gradually increase the number of segments and look for the point where no further significant changes in the results are observed. This is commonly called *convergence testing* (see also Chapter 4).

Fig 9-62 shows an example of a straight vertical for 80 meters (19 meters long). This antenna consists of a single wire. To evaluate the effect of the segment length, I varied the number of segments in the wire from five to 150. Gain and pattern are very close to modeling with only five segments compared to 150. For impedance calculations, at least 20 sections are required for a reasonably accurate result. The table in Fig 9-62 also shows an example of too many segments for a vertical measuring 250 mm in diameter. As the segment length becomes very short in comparison to the wire diameter, the results become erroneous.

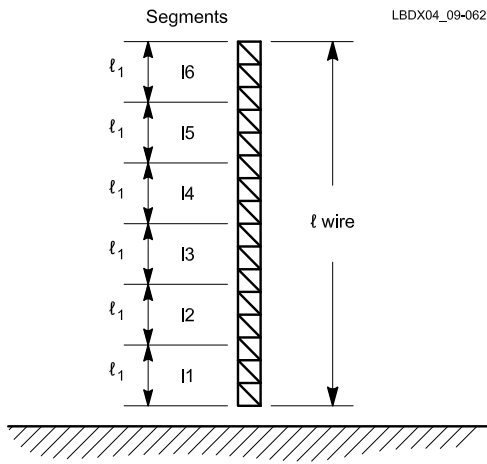

LBDX04_09-062

Number of Segments	Segment Length (mm)	2 mm OD Wire (AWG No. 12)	250 mm Mast Diam
5	3800	43.1 - j10.9	36.0 + j3.0
10	1900	34.4 - j11.6	37.0 + j4.1
20	950	34.6 - j11.2	37.5 + j5.2
30	630	34.6 - j11.0	37.7 + j5.8
50	380	34.7 - j10.8	38.0 + j6.2
70	240	34.7 - j10.8	38.0 + j6.3
100	190	34.7 - j11.1	34.5 - j13.0
150	130		34.0 - j14.0

Fig 9-62—*MININEC* analysis of a straight 19-meter vertical antenna shown in the drawing. The analysis frequency is 3.8 MHz. *MININEC* impedance results are shown as a function of the number of segments in the table. Note that for reliability with a “fat” (200-mm) vertical, the maximum number of segments (in this case segments = pulses) is 70. The *MININEC* documentation states that the segment length should be greater than 2.5 times the wire diameter (2.5×200 mm = 500 mm). In this particular case errors occur when the segment length is smaller than the wire diameter.

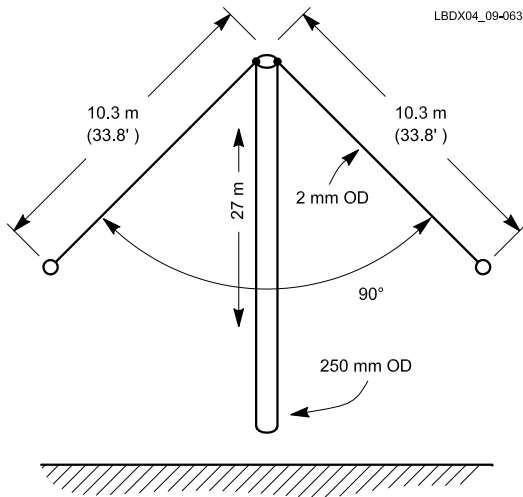

LBDX04_09-063

Fig 9-63—Impedances calculated by *MININEC* for a top-loaded 1.8-MHz vertical, using a 250-mm OD mast and two 2-mm OD slant loading wires. The segment lengths are stated in mm. A large number of segments on all wires always gives more reliable results, provided the segment length is not very different. Judicious choice of segment length on the different wires can also yield very accurate results with a smaller number of total segments. To obtain accurate impedance results using *MININEC*, the wire sections near the acute-angle wire junctions must be short.

Vertical Mast			Slant Wires		Total Pulses	Impedance	
No. of Segments	Segment Length (min.)	Segment Length (max.)	No. of Segments	Segment Length (min.)			
3	9000	9000	3	3765	3765	9	9.0 - j184.0
5	5400	5400	5	2260	2260	1	14.2 - j107.0
10	2700	2700	10	1130	1130	3	16.2 - j83.5
20	1350	1350	20	565	565	6	16.6 - j87.1
30	900	900	30	437	437	9	16.7 - j77.0
40	625	625	40	282	282	120	16.6 - j76.5
50	540	540	50	226	226	150	16.8 - j76.3
10	2700	2700	5	2260	2260	15	16.8 - j78.6
6	4500	4500	2	5650	5650	10	16.8 - j80.4
5	5400	5400	2	5650	5650	9	16.7 - j80.7
35	770	770	2	5650	5650	39	14.9 - j103.0

f = 1.8 MHz
length of vert mast = 27 m
slant wire = 10.3 m

5.2. Modeling Antennas with Wire Connections

When the antenna consists of several straight conductors, things become more complicated. Fig 9-63 shows the example of a 27-meter vertical tower (250-mm OD), loaded with two sloping top-hat wires, measuring 2-mm OD (AWG #12).

The standard approach is to use three wires, one for each of the three antenna parts, and divide the three conductors into a number of segments (which are equal length inside each wire).

To obtain reliable results, you must make sure that the lengths of the segments near the junctions of wires are similar. The table in Fig 9-63 shows the impedance obtained for the top-loaded vertical with different numbers of segments. A large number of segments on the vertical mast (eg, 35 segments, which results in a segment length of 770 mm), together with a small number of segments on the sloping wires, give an unreliable result, while a good result is obtained with a total of just nine segments if the lengths are carefully matched. The segment tapering technique, described in Chapter 14 on Yagis and quads, can also be used to minimize the number of segments and improve the accuracy of the results.

5.3. Modeling Verticals Including Radial Systems

MININEC does not analyze antenna systems with horizontal wires close to the ground. Therefore, modeling ground systems as part of the antenna requires the NEC software. NEC-2, or software such as EZNEC, which uses the NEC-2 engine, can model radials over ground. There seem, however, documented cases (models verified against real-world measurements) of NEC-2 giving very optimistic results (sometimes up to nearly 6 dB too high gain). NEC-3 and NEC-4 can model buried radials (see Chapter 4, Section 1.4), but apparently still show optimistic gain values for wires very close to ground. The results of modeling buried radial systems (see Sections 2.1.2 and 2.1.3) are largely confirmed by N7CL's experimental work. While we can't be absolutely sure real gain figures match modeled numbers within fractions of a dB, nonetheless the trends are certainly correct.

5.4. Radiation at Very Low Angles

Most modeling programs most amateurs use show zero radiation at zero elevation and very little at low angles, unless over salt water. How can we hear ground-wave signals even over average ground? We should not, according to what the model tells us. Experiments show that in real life the very low-angle performance of vertical is better than these modeling programs tell us.

5.5. Measurements, Verifications, Real Life

It is beyond the reach of almost all amateurs to do real-life experiments with low band antennas. The reasons are many. Verifications of modeling results can only be done by few, because of lack of test equipment and most of all the necessary acres... On the other hand, modeling involves mathematics, and a computer can show us results expressed in fractions of a dB. Some models were never verified, and we suspect that the error could be many dBs... Modeling most often does seem to make sense if you compare one model to another model, but you should not automatically conclude that

the results apply directly to the real world!

6. PRACTICAL VERTICAL ANTENNAS

A number of practical designs of verticals for 40, 80 and 160 meters are covered in this section, as well as dual and tri-band systems. A number of practical matching cases are solved, and the component ratings for the elements are discussed. All the L networks have been calculated using the L-NETWORK DESIGN module from the NEW LOW BAND SOFTWARE.

6.1. Single-Band Quarter-Wave Vertical for 40, 80 or 160

Large-diameter conductors are used for various reasons, such as increasing the bandwidth (by increasing the D/L ratio) or simply for mechanical reasons. The effective diameter of wire cages and flat multi-wire configurations is covered in Chapter 8 in Section 2.4.

Often, triangular tower sections are used to make vertical antennas. The effective equivalent diameter of a tower section is shown in Fig 9-64. A tower section measuring 25-cm wide, with vertical tubes measuring 2.5-cm diameter, has an equivalent diameter of $0.7 \times 25 = 17.5$ cm.

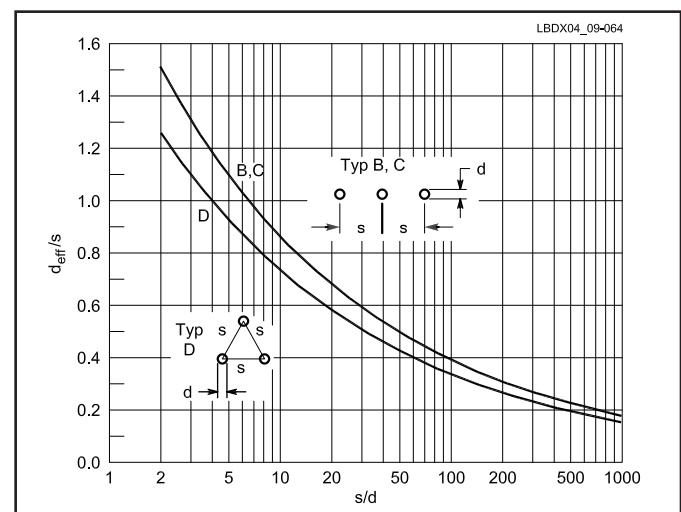

Fig 9-64—Normalized (round solid conductor) effective diameter of a triangular tower section as a function of the vertical tube diameter (d) and the tower width (s). The graph for three parallel conductors is also given (curve BC). (After Gerd Janzen, *Kurze Antennen*.)

Table 9-7

$\lambda/4$ Resonance for Vertical as Function of Length/Diameter

Length/Diameter Ratio	Shortening Factor (%)
5000	97.3
2500	97.1
1000	96.8
500	96.2
250	95.7
100	94.6
50	93.4

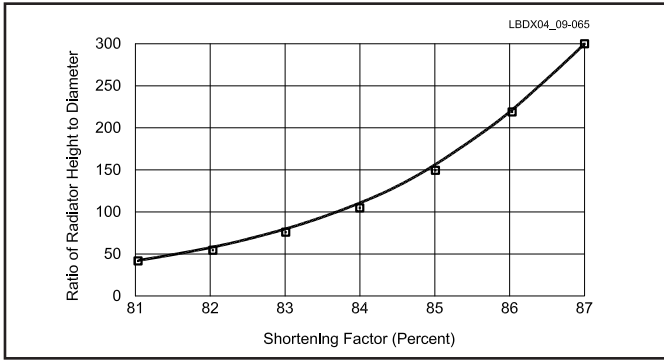

Fig 9-65—Graph showing the amount a $\lambda/4$ vertical must be shortened for resonance as a function of the length-to-diameter ratio.

The length of a resonant full-size quarter-wave vertical depends on its physical diameter. See **Table 9-7**, which shows the physical shortening factor of a $\lambda/4$ resonant antenna as a function of the ratio of antenna length to antenna diameter. The required physical length is given by:

$$L = \frac{74.95 \times p}{f_{\text{MHz}}}$$

where

L = length (height) of the vertical in meters

SF = correction factor (from **Fig 9-65**)

f_{MHz} = design frequency in MHz.

Quarter-wave verticals are easy to match to 50- Ω coaxial feed lines. The radiation resistance plus the usual earth losses will produce a feed-point resistance close to 50 Ω .

If you don't mind using a matching network at the antenna base, and if you can manage a few more meters of antenna height, the extra height will give you increased radiation resistance and higher efficiency. The feed-point impedance can be found in the charts of Figs 9-9, 9-10, 9-12 and 9-13.

Consider the following examples (see **Fig 9-66**):

Example 1:

Tower height = 27 meters

Tower diameter = 25 cm

Design frequency = 3.8 MHz

From the appropriate charts or through modeling we find:

$$R = 185 \Omega$$

$$X = +j 215 \Omega$$

Let's assume we have a pretty good ground radial system, with an equivalent ground resistance of 5 Ω . We calculate the matching L network with the following values:

$$Z_{\text{in}} = 190 + j 215 \Omega$$

$$Z_{\text{out}} = 50 \Omega$$

The values of the matching network were calculated for 3.8 MHz. The two matching-network alternatives (low and high-pass) are shown in Fig 9-66A. The low-pass filter network gives a little additional harmonic suppression, while the high-pass assures a direct dc ground for the antenna and some rejection of medium-wave broadcast signals.

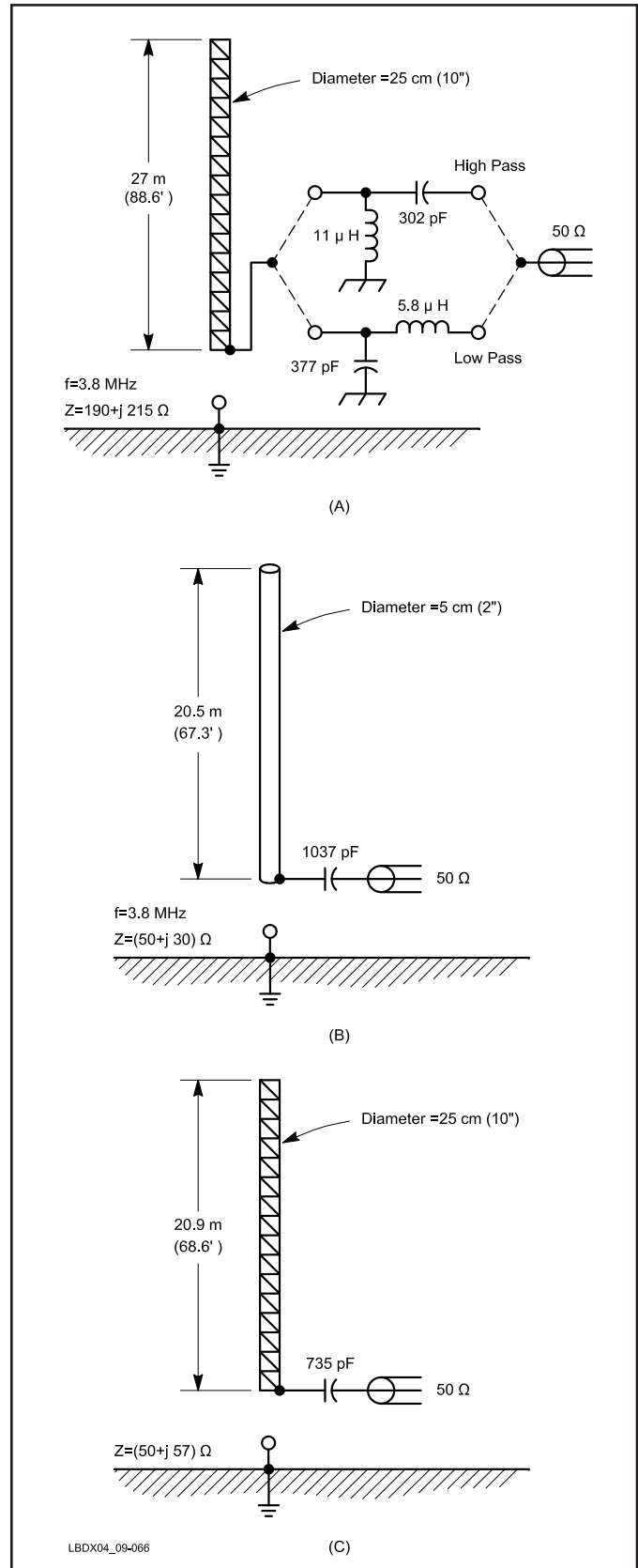

Fig 9-66—Three different 80-meter verticals that are no longer than $\lambda/4$, together with their matching networks. Designs at B and C are dimensioned in such a way that the resistive part of the impedance is 50 Ω , in which case the matching network consists of only a series capacitor. The difference between B and C is the diameter of the vertical. In all cases a perfect ground (zero loss) is assumed.

Example 2:

This time we are setting out to build a vertical that is a little longer than a $\lambda/4$, so the resistive part of the feed-point impedance at the design frequency will be exactly 50Ω . This matching network will consist of a simple series capacitor to tune out the inductive reactance of the feed-point impedance. We use *ELNEC* to design two models:

- Vertical mast diameter = 5 cm, length = 20.5 meters, $Z = 50 + j 39 \Omega$ (see Fig 9-64B). The matching network consists of a series capacitor with a reactance of 39Ω at 3.8 MHz. The value of the capacitor is:

$$C = \frac{10^6}{2\pi \times 3.8 \times 39} = 1073 \text{ pF}$$

- Vertical mast diameter = 25 cm, length = 20.9 meters, $Z = 50 + j 57 \Omega$ (see Fig 9-64C). In this case the series-matching capacitor has a value of 735 pF.

Note that for the above examples we assumed a zero ground loss. The values of the series-matching capacitor can also be calculated using the *SERIES IMPEDANCE* module of the *NEW LOW BAND SOFTWARE* package.

What type of capacitor should you use? The current requirement can be calculated as follows: $I = \sqrt{P/R}$. For 1.5 kW, $I = \sqrt{1500/50} = 5.48 \text{ A}$. For voltage, $E =$

$\sqrt{PR} = \sqrt{1500 \times 50} = 274 \text{ V}$. These are RMS values, so you should use components that are built to withstand two to three times these values (a vacuum variable is recommended).

6.1.1. Mechanical design

I don't want to give many detailed mechanical designs, listing materials, tubing diameter, etc since their availability is different in every country. Guy Hamblen, AA7QZ/2, described an attractive 80/75-meter design that uses 12-foot long aluminum tubing sections ranging from 1.5-inch OD to 0.875-inch OD. He also describes the installation details (Ref 7819).

If you consider making a vertical with a rather long un-guyed top section, you can use the *ELEMENT STRENGTH MODULE* of the *ON4UN YAGI DESIGN SOFTWARE*. Using the software you can design a Yagi element with a length equal to twice the length you need for the non-guyed top section of the vertical. Because this top section, unlike the Yagi half-element, will not be loaded by its own weight (causing the sag in a Yagi element), the vertical section will have an added safety factor.

Fig 9-68 shows the design for an 80-meter vertical using 4 and 3-inch aluminum irrigation tubing, as designed by Steve Kelly, K7EM. The verticals are mounted on 6x6-inch pressure treated lumber. The total length of each post is 12 feet, of which 4 feet is in the ground. The arms that hold the verticals in place are made from 2x6-inch lumber. Steve used $3/8$ -inch threaded rod to bind the arms to the posts and a $1/2$ -inch threaded rod goes through the base of each vertical (see **Fig 9-69**). The $1/2$ -inch rod acts as a hinge for raising and lowering and is insulated from the vertical with PVC tubing. Steve recently replaced the 2x6-inch lumber with $1/2$ -inch thick Plexiglas sheet. The bottom ends of the 4-inch tubing is insulated by 4-inch (inside diameter) PVC pipe. Steve mentions splitting this pipe lengthwise, heating it with a special PVC bending blanket and then sliding it over the 4-inch irrigation tubing.

6.2. Top-Loaded Vertical

The design of loaded verticals has been covered in great detail in Section 3.6. Capacitive top loading using wires (usually slightly sloping) are quite easily constructed from a mechanical point of view. It is more difficult to insert a husky loading coil in a vertical antenna. In addition, because of their intrinsic losses, loading coils are always a second choice when it comes to loading a vertical.

A wire-loaded vertical for 160 meters is described in Section 6.4 as part of an 80/160-meter duoband system. Inverted-L antennas, which are a specific form of top-loaded verticals, are the subject of Section 7.

6.3. Duo-Bander for 80/160 Meters

Full-size, $\lambda/4$ verticals (40-meters tall on 160 meters) are out of reach for most amateurs. Often an 80/160-meter duoband vertical will be limited to a height of around 30 meters. This represents an electrical length of 140° at 3.65 MHz and 70° on 160 meters. We can determine R and X from Figs 9-9 and 9-11 or through modeling:

$$\begin{aligned} 80 \text{ meters: } Z &= 280 + j 278 \Omega \\ 160 \text{ meters: } Z &= 17 - j 102 \Omega \end{aligned}$$

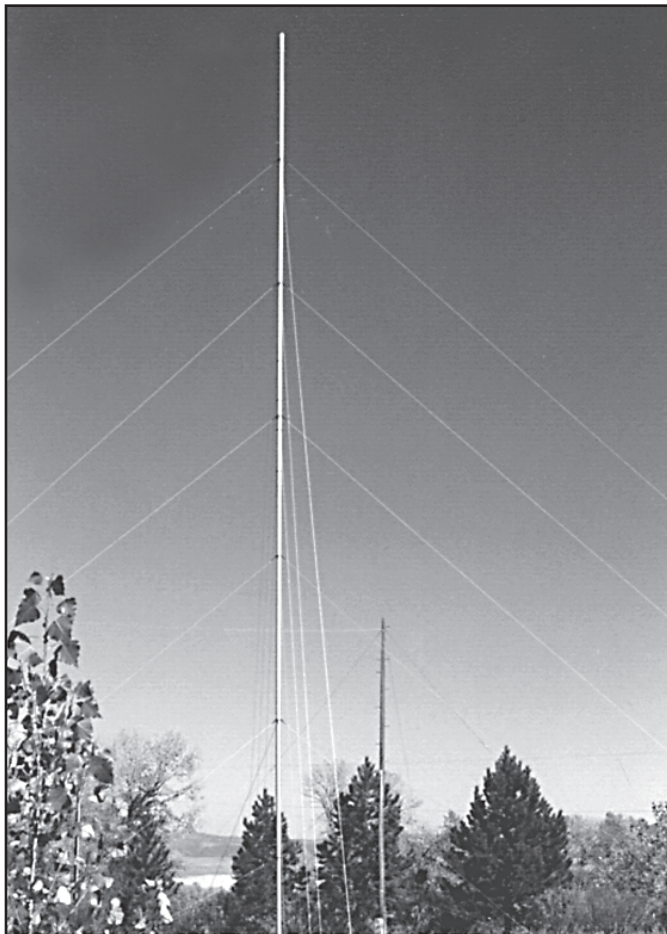

Fig 9-67—Ninety-foot irrigation-pipe vertical at W7LR in Montana, which is used for both 80 and 160 meters.

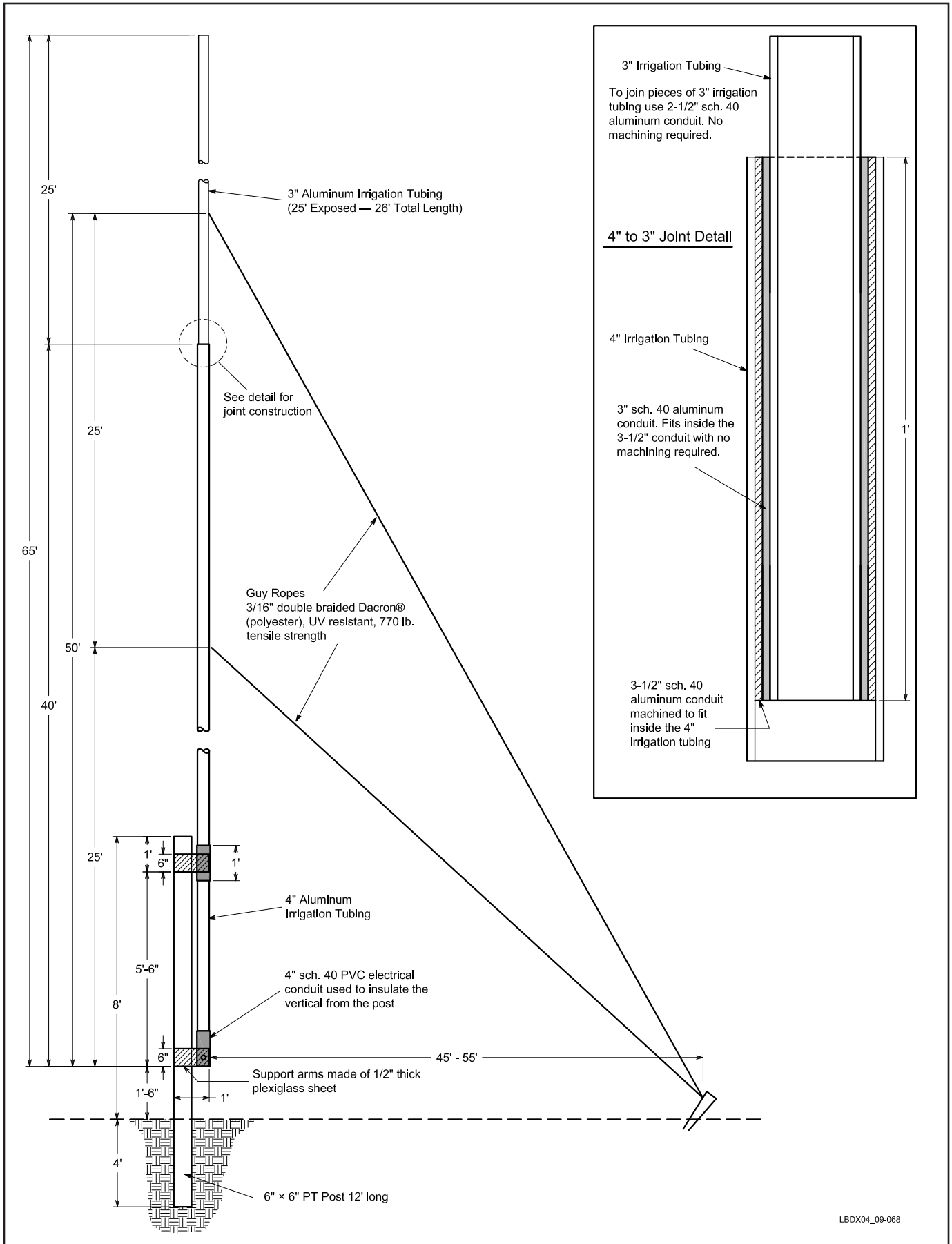

Fig 9-68—Construction details for 80-meter $\lambda/4$ elements made of 4-inch and 3-inch irrigation tubing designed by K7EM.



Fig 9-69—Base of one of the irrigation-pipe 80-meter verticals constructed by K7EM.

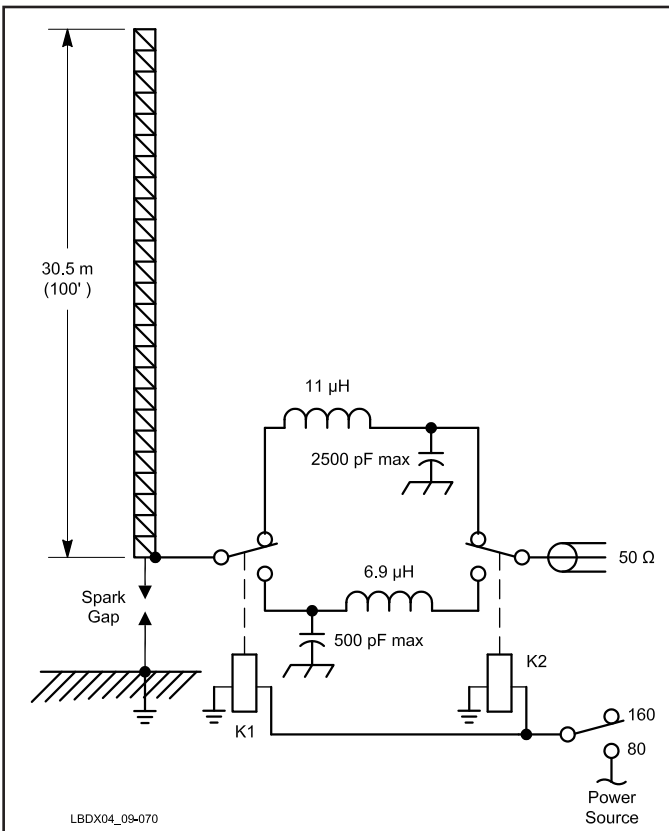

Fig 9-70—Two-band (80 and 160-meter) vertical system using L-networks to match the 50-Ω feed line. The values of the L networks were calculated assuming an equivalent ground-loss resistance of 10 and 5 Ω respectively on 160 and 80 meters.

We use L-networks to match these impedances to our feed line. It's a good idea to use your antenna analyzer to check the impedances on 80 and 160. They should be close to those mentioned above. Remember that the magnitude of the reactive part depends on the effective diameter of the antenna (large diameter antennas exhibit less reactance). Use the L-networks section of the NEW LOW BAND SOFTWARE to calculate the component values. Fig 9-70 shows the antenna configuration together with the switchable matching system.

6.4. 80/160 Top-Loaded Vertical with Trap

Traps are frequency-selective devices incorporated in radiating elements to adapt the electrical length of the element depending on the frequency at which the element is being used.

Commercial multiband antennas make frequent use of traps. Home-made antennas use the technique less often. There are two types of commonly used traps:

- Isolating traps
- Shortening/lengthening traps

For details about traps and modeling antennas, visit: www.cebik.com/trap.html.

6.4.1. Isolating traps

An isolating trap is a parallel-tuned circuit that presents a high impedance at the design frequency, effectively decoupling the “outer” section of the radiator from the “inner” section. A good isolating trap meets the following specifications:

- It represents a high impedance on the design frequency.
- It represents as low a Q as possible, together with the high impedance.
- It represents as low a series inductance as possible on the frequencies where the trap is not resonant (minimize inductive loading), unless you want to use the trap off resonance as a loading device, which could shorten or lengthen the element. The LC circuit off resonance acts as an L or a C, depending which side of resonance you are.

Traps have been described in literature in several configurations:

- Regular LC parallel-tuned circuits
- Resonant circuits with the coil created by a so-called linear loading device (for example, see KT34 Yagis)
- Traps made with coaxial cable, where the capacitance of the cable is used as capacitor, and where the cable shield acts as the coil in the resonant circuit.

Losses are the main issue with traps. An ideal trap will have an infinite parallel (shunt) loss resistance (R_p). Tom, W8JI investigated different traps and found the following results.

- Copper tubing and vacuum cap: $R_p = 300,000 \Omega$
- 60-pF doorknob and #10 Airdux coil: $R_p = 250,000 \Omega$
- 100-pF doorknob and #12 Airdux coil: $R_p = 99,850 \Omega$
- Mosely TA33: $R_p = 79,000 \Omega$
- Cushcraft A3 $R_p = 76,270 \Omega$
- Coax RG-58/U $R_p = 17,800 \Omega$
- Teflon-insulated semi-rigid copper tubing type coax: $R_p = 45,000 \Omega$.

W8JI adds: “Stubs, linear-loading, and coaxial-cable

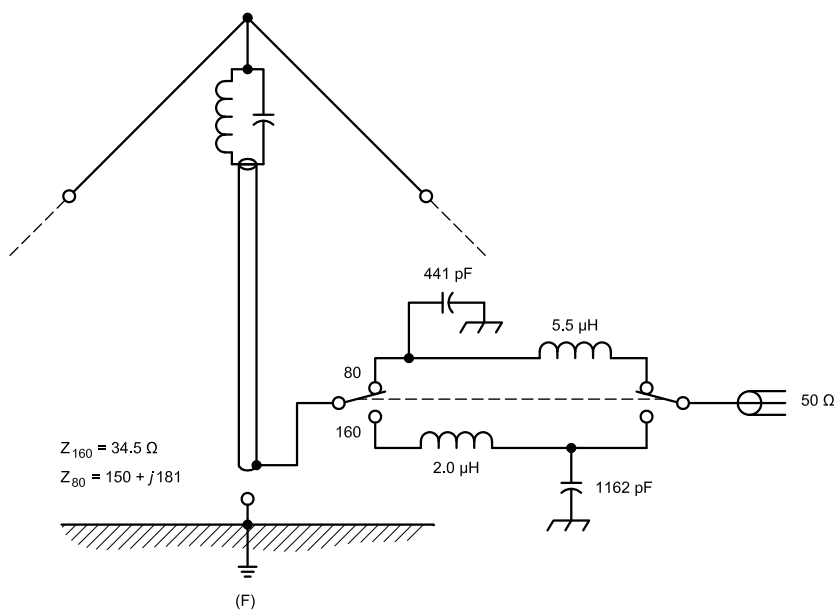
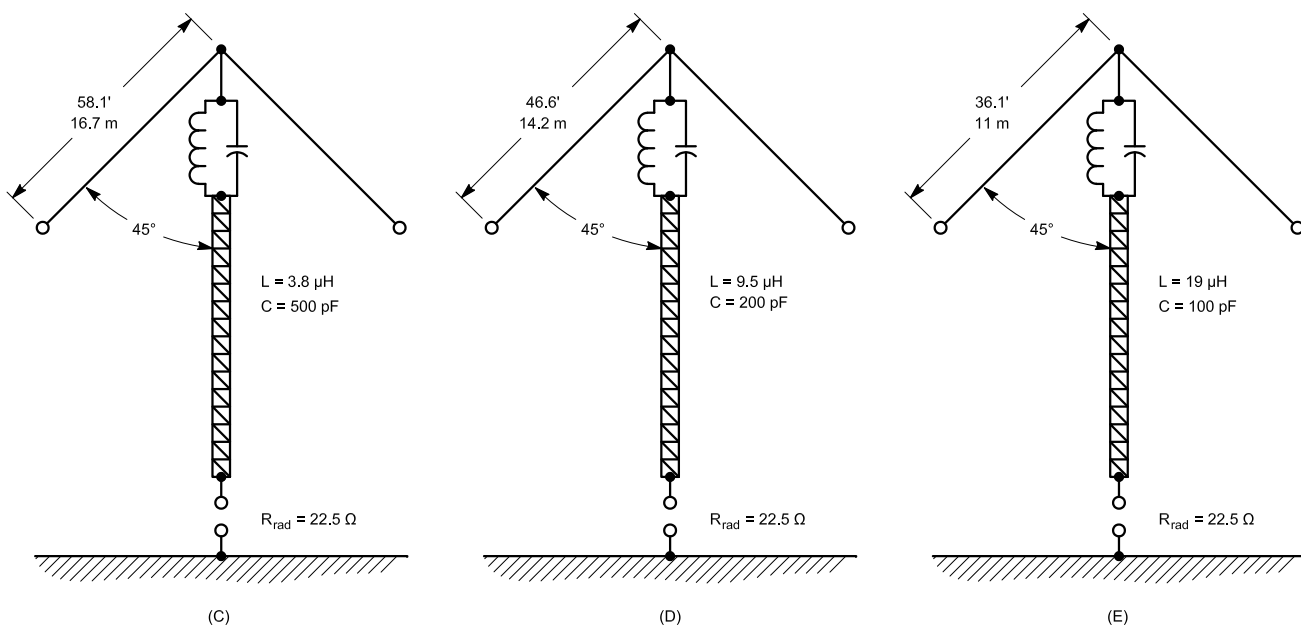
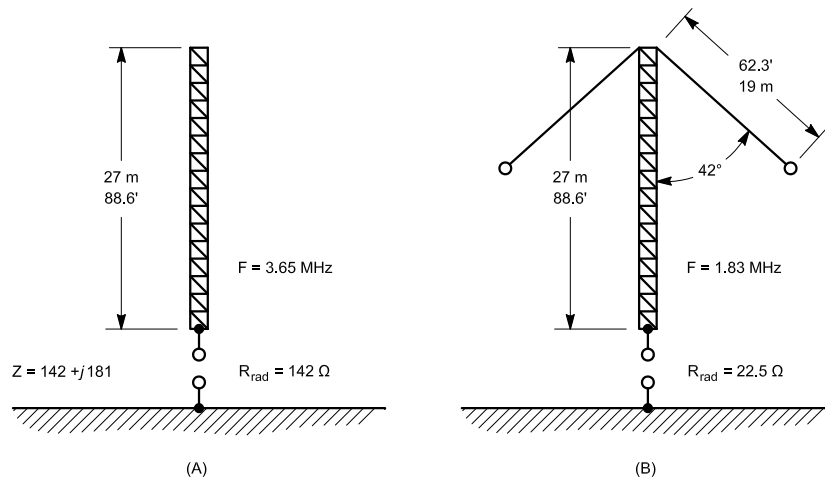

Fig 9-71—Evolution of a duoband trap-antenna design for 80 and 160 meters. For reference the equivalent 80 and 160-meter antennas without the trap are shown at A and B. Three trap configurations with discrete components (low, medium and high L/C ratios) are shown at C, D and E, while that at F uses a coaxial-cable trap. The four final designs show the matching networks for an equivalent ground resistance of 12 and 8 Ω respectively on 160 and 80 meters.

LBDX04_09-071

capacitors generally have very low Q compared to other systems. Expect about 1.5 dB or so loss for a coaxial trap in an Inverted L or vertical at the trapped frequency. Loss using a small Airdux coil and a doorknob capacitor would be less than 0.25 dB. Loss on other than the exact trapping frequency are insignificant with all types of traps.”

The exception would be traps using very low C and high inductive reactance, which may have significant loss at the pass frequency. This type of trap would be the high-inductance coils used to isolate antenna sections while, substantially reducing length on the non-trap frequency (as sometimes used in small Yagis). Those traps can seriously degrade the pass-frequency performance.

The example in Fig 9-71 shows a 27-meter vertical mast, measuring 25 cm in effective diameter. We want to use this mast on 80 meters and load it to resonance on 160 meters using two flat-top wires. The trap at the top of the vertical will isolate the loading wires from the mast when operating on 80 meters; it will have to be resonant on 80 meters. Let us design a system that covers 3.5 to 3.8 MHz and see what the performance will be when compared to two monoband systems using basically the same configuration.

Resonance of the trap at 3.65 MHz can be obtained with an unlimited number of L/C combinations:

$$F_{\text{res}} = \frac{10^3}{2\pi\sqrt{LC}}$$

where f is in MHz, L in μH and C in pF.

Let us evaluate three different L/C ratios that resonate at 3.65 MHz:

$L = 3.8 \mu\text{H}$, $C = 500 \text{ pF}$ ($X = 87 \Omega$)

$L = 9.5 \mu\text{H}$, $C = 200 \text{ pF}$ ($X = 218 \Omega$)

$L = 19 \mu\text{H}$, $C = 100 \text{ pF}$ ($X = 436 \Omega$)

Use standard capacitor values (doorknob or high-quality ceramic-transmitting type capacitors) and adjust the coil turns to obtain the desired resonant frequency, as measured with a Grid Dip meter. The winding data for the coil can be calculated using the COIL module of the NEW LOW BAND SOFTWARE.

As standards of comparison we'll use the stand-alone 27-meter tower (no trap, no flat-top wires) on 80 meters, and the same 27-meter tower with two sloping flat-top wires on 160 meters. The dimensions of the five different configurations are shown in Fig 9-71.

The impedance at 1.835 MHz (resonance with the loading wires, Fig 9-71B) is 22.5Ω . At 3.65 MHz (Fig 9-71A) the feed-point impedance is $142 + j 181 \Omega$.

Fig 9-72 shows the influence of the slope angle of the top wires on the resonant frequency. The values are for a 27-meter vertical with two sloping loading wires, 19 meters long.

The three different trap solutions (different L/C ratios) have a significant influence on the SWR-bandwidth behavior of the antenna. The influence of the L/C ratio is the opposite on 80 meters from what it is on 160. The low-L, high-C solution ($3.8 \mu\text{H}$ and 500 pF) yields the highest bandwidth on 160, and the lowest bandwidth on 80 meters. The opposite is also true. With $L = 19 \mu\text{H}$ and $C = 100 \text{ pF}$, the SWR curve on 80 is almost as flat as for the reference antenna (just the 27-meter vertical with no trap nor loading wire).

The bandwidth results for the different designs are shown in Fig 9-73 for both 80 and 160 meters. I have calculated the theoretical bandwidth, excluding the ground losses, as well as the practical bandwidth, including ground losses.

Solution two ($9.5 \mu\text{H}$ and 200 pF , Fig 9-71D) is certainly an excellent compromise if both bands are to be treated with equal attention. This antenna should be matched at the bottom using L-networks (one for each band). Alternatively, you could use a 2:1 unun on 160 meters, but you would still need an L-network on 80 meters.

6.4.2. Shortening/lengthening traps

If the isolating trap principle were to be used on a triband antenna, it would require two isolating traps. Three-band trap Yagis of the early sixties indeed used two traps on each element half, the inner one being resonant on the highest band, the outer one on the middle band. Modern trap-design Yagis only use a single trap in each element half to achieve the same purpose. Y. Beers, WØJF, wrote an excellent article covering the design of these traps (Ref 680). In this design, the trap is not resonant on the high-band frequency, but somewhere in between the low and the high band. In the balanced design described by Y. Beers, the frequency at which the trap is resonant is the geometrical mean of the two operating frequencies (equal to the square root of the product of the two operating frequencies). For an 80/160-meter vertical, the trap would be resonant at:

$$f = \sqrt{1.83 \times 3.85} = 2.65 \text{ MHz}$$

On a frequency below the trap resonant frequency the trap will show a positive reactance (it acts like an inductor), while above the resonant frequency the trap acts as a capacitor. A single parallel-tuned circuit can be designed that inserts the necessary positive reactance at the lowest frequency and negative reactance at the highest frequency. In the balanced design the absolute value of the reactances is identical for the two bands; only the sign is different. There are five variables

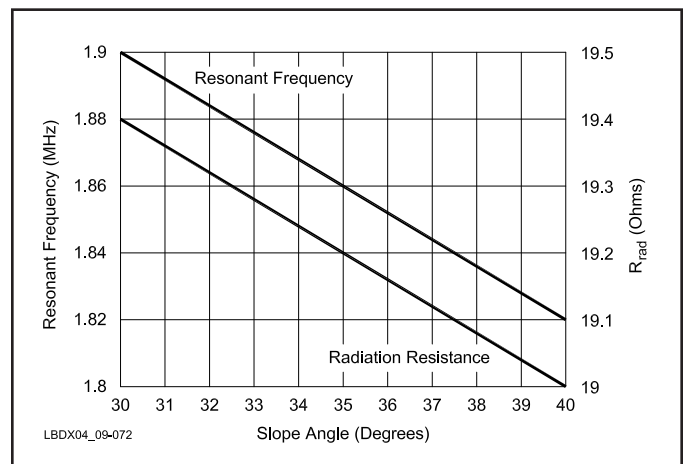

Fig 9-72—This chart shows the variation in resonant frequency and radiation resistance for a 27-meter vertical with 19-meter long sloping top-load wires. A change in slope angle of 30° to 40° shifts the resonant frequency by 80 kHz.

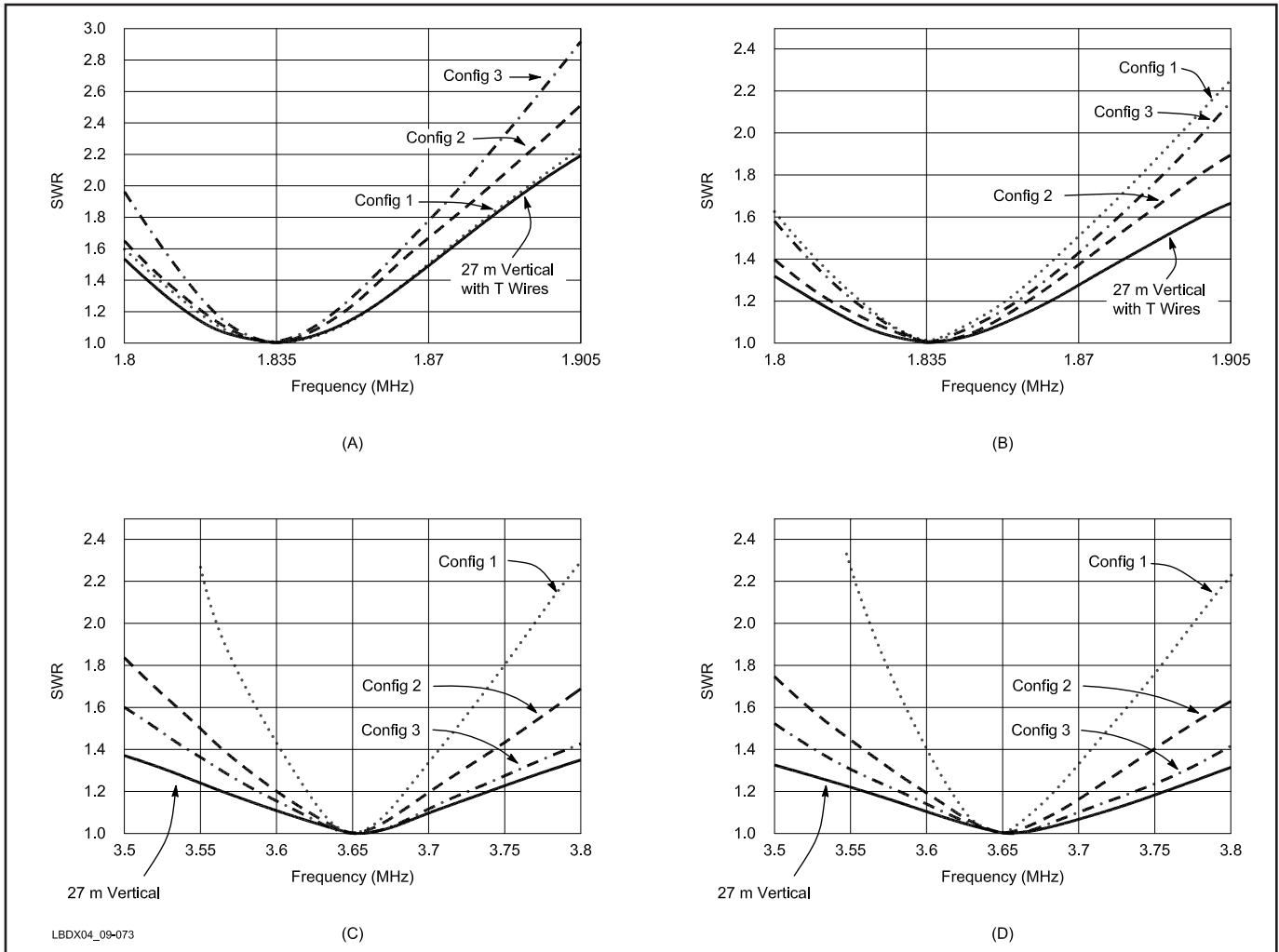

Fig 9-73—SWR curves for 80 and 160 meters for the different antenna configurations of Fig 9-71. Config 1 refers to Fig 9-71C, Config 2 to Fig 9-71D, and Config 3 to Fig 9-71E. The curves are plotted for perfect ground (at A and C) as well as for real ground (at B and D). Note the increased bandwidth on 160 meters caused by the ground losses and the low R_{rad} . On 80 meters the ground losses have almost no influence due to the high R_{rad} .

involved in the design of such a trap system: the two operating frequencies, the trap resonant frequency, the total length and the L/C ratio used in the trap parallel circuit. The design procedure and the mathematics are covered in detail in the above-mentioned article.

It's clear that the "isolating" trap we designed in Section 6.4.1 was really a lengthening trap as we designed it to be a trap slightly lower than 80 meters.

6.5. The Self-Supporting Full-Size 160-Meter Vertical at ON4UN

A full-size $\lambda/4$ vertical antenna for 160 meters is just about the best transmitting antenna you can have on that band, with the exception of an array made of full-size or top-loaded verticals. I use a 32-meter triangular self-supporting tower, measuring 1.8 meters across at the base, and tapering to 20 cm at the top. I knew that the taper would make the tower electrically shorter than if it had a constant diameter, so that had to be accounted for. On top of the tower I mounted a 7-meter-long mast. It is steel at the bottom and aluminum at the top, tapering from 50-mm OD to 12 mm at the top.

To make up for the shortening due to the tower taper, I

knew I had to install a capacitance hat somewhere near the top of the tower. The highest point I could do this was at 32.5 meters. I decided to try a disk with a diameter of 6 meters, because I had 6-meter-long aluminum tubing available. Two aluminum tubes were mounted at right angles, the ends being connected by copper wire to make a square. Fig 9-74 shows my vertical.

I hoped I would come close to an electrical $\lambda/4$ on 160 meters, and fortunately the antenna resonated on exactly 1830 kHz. In the beginning I had the tower insulated at the base, and was able to measure its impedance, approximately 20 Ω , while I expected 36 Ω with a 0- Ω earth-system resistance. Such a low radiation resistance has been reported in the literature, and must be due to the large tower cross-section. Originally I suspected mutual coupling with one of two other towers (or both), but decoupling or detuning those towers did not change anything.

Fig 9-75 shows the radiation resistance of a $\lambda/4$ vertical over a radial system consisting of 60 $\lambda/4$ radials, measured as a function of the diameter of the vertical. You can see that for a height/diameter ratio of 44 (eg, a self-supporting tower with a diameter of 1 meter operating at 1.83 MHz) the radiation



Fig 9-74—Self-supporting 39.5-meter $\lambda/4$ vertical for 160 meters at ON4UN. The base is 1.8-meters wide and the tower tapers to just a few inches at the top. The tower is shunt fed with a gamma match and also serves as a support for an 80-meter Four-Square array made of $\lambda/4$ verticals, supported from sloping catenary lines running from the 160-meter tower.

resistance should be about 20 Ω . The classic 36- Ω figure applies for a very thin conductor!

After a series of unsuccessful attempts to use the vertical on 80 meters, I grounded the tower and shunt fed it using a gamma match for 160 meters and dropped the idea of using this “much-too-long” tower on 80 meters. A tap 8-meters high, and a 500-pF series capacitor provided a 1:1 SWR on Topband, and a 2:1 SWR bandwidth of 175 kHz. The gamma wire is approximately 1.5 meters from the tower. This vertical really plays extremely well. I use quite an extensive radial system, consist-



Fig 9-76—Giving out new countries and chasing new countries on 160 meters are not the only hobbies for Rudi, DK7PE, (left) and ON4UN, who are ready to go on a bike trip. In the background is the base of ON4UN’s 160-meter vertical showing the cabinet that houses the matching circuitry for the 160-meter vertical and the Four-Square 80-meter system.

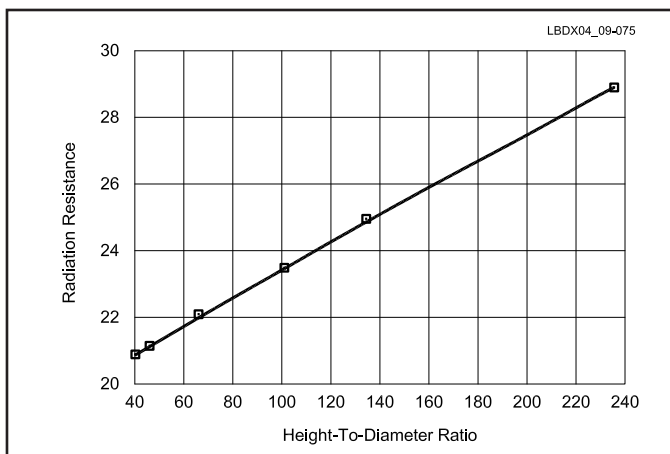

Fig 9-75—The feed-point resistance of a resonant $\lambda/4$ vertical over 60 $\lambda/4$ radials, as a function of the conductor diameter. Verticals made of a large-diameter conductor, such as a tower, exhibit much lower feed-point resistances than encountered with wire verticals.



Fig 9-77—The base of ON4UN’s 160-meter vertical and the cabinet housing both the 80-hybrid-coupler Comtek and WX0B Lahlum networks for the 80-meter Four Square. R. Vermet, ON6WU, with his professional antenna measuring setup, tunes the 80-meter vertical. An HP network analyzer is used that directly produces a Smith Chart.

ing of approximately 250 radials ranging from 18 to 75 meters in length. The tower now also supports a Four Square sloping $\lambda/4$ vertical array as described in the chapter on vertical arrays.

Fig 9-76 shows the vertical's base and the cabinet housing the series capacitor for the 160-meter gamma match (as well as the hybrid coupler for the 80-meter Four-Square array). I obtained detailed feed-point information for the ON4UN vertical with the assistance of ON6WU and his professional-grade test equipment (HP Network analyzer). See **Fig 9-77**.

6.6. The Battle Creek Special Antenna

Everyone familiar with DX operating on 160 meters has heard about the Battle Creek Special and its predecessor, the Minooka Special. These antennas are transportable verticals for operating on the low bands. The Minooka Special (Ref 761) was designed by B. Boothe, W9UCW, for B. Walsh, WA8MOA, to take on his trips to Mellish Reef and Heard Island many years ago.

Basically the antennas were designed to complement a triband Yagi on DXpeditions to provide excellent six-band coverage for the serious DXpeditioner. The original Minooka was a 40 through 160-meter antenna, using an L network for matching and an impressively long 160-meter loading coil near the top. W0CD built a very rugged and easily transportable version of the Minooka Special, but soon found out that the slender loading coil simply melted when the antenna was taking high power for longer than a few seconds. No wonder! It was more than 100-cm long with a diameter of only 27 mm. Michaels, W7XC, later calculated the Q factor of the coil to be around 20! That's an equivalent loss resistance of 100 Ω !

W0CD improved the antenna both mechanically and electrically. Instead of developing a better loading coil, he simply did away with the delicate part, and replaced the loading coil with a loading wire. His design uses two sloping wires, one for 80 meters and one for 160, which now makes it really an inverted L, but nothing would prevent you from using a T-shaped loading wire as described in Section 3.6.4.

The new design, named the Battle Creek Special, takes 1.5 kW of RF on SSB or CW without any problem for several minutes. For continuous-duty digital modes the RF output should not exceed 600 W. An 80-meter trap isolates the loading wires for 80 and 160.

The section below the 40-meter trap is 9.75 meters long, which makes it a full-size quarter-wave on that band. The SWR bandwidth is less than 2:1 from 7 to 7.3 MHz.

On 80 meters the 15 meters of tubing below the 80-meter trap, together with the loading wire, make it an inverted L. The antenna will cover 3.5 to 3.6 MHz with an SWR of less than 2:1. On 3.8 MHz the antenna is "too long," but a simple series capacitor of 200 to 250 pF will reduce the SWR to a very acceptable level (typically 1.3:1).

On 160 meters the entire vertical antenna plus the top-loading wire make it a $\lambda/4$ L antenna. The SWR is typically 2:1 over 20 kHz, indicating a feed-point impedance of approximately 25 Ω (depending to a large extent on the quality of the radial system).

There are several ways to obtain a better match to the feed line. W0CD uses an unun with a 2:1 impedance ratio (see also Chapter 6 on Feed Lines and Matching). The unun is switched in the circuit on 160 meters, and out of the circuit on 80 and 40 meters. Under certain circumstances it can be even advantageous to use the unun on the higher bands as well. The unun is

an unbalanced-to-unbalanced wideband toroidal transformer (Ref 1521 and 1522). W0CD actually built a 9:4 (2.25:1) balun, and removed the top turn to get an exact 2:1 ratio.

Another alternative is to use an L network. A simple tunable L network that has been especially designed for matching "short" 160-meter loaded verticals is shown in **Figs 9-78 and 9-79**. The L network was made by ON7TK and has been traveling around the world on various DXpeditions (A61, 9K2, FO0C, etc).

The Battle Creek Special uses high strength aluminum tubing, 6061-T6 alloy, in sizes ranging from 2 inches to 1 inch (5 to 2.5 cm). The guy lines are 2.4-mm Dacron double-braided rope with a rating of 118 kg breaking strength. Wind survival rating is 160 k/hr assuming proper guy-rope anchors.

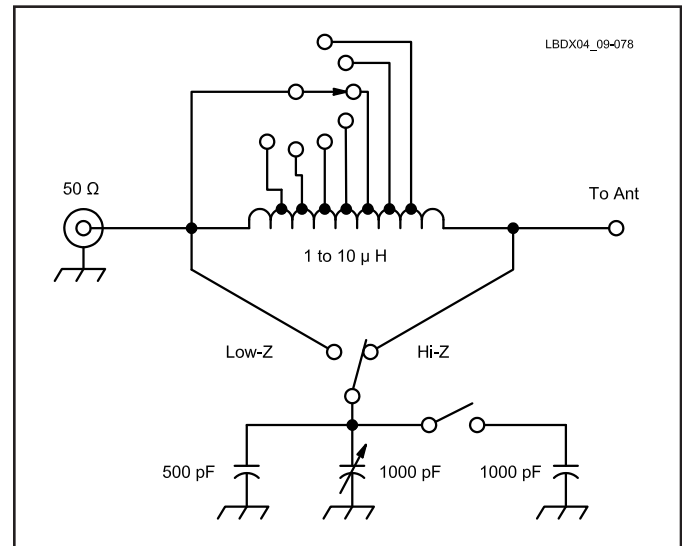

Fig 9-78—L network to be used with Inverted-L antennas and other loaded 160-meter verticals. With the component values shown, impedances in the range $20 - j 100$ to $100 + j 100 \Omega$ can easily be matched on 160 meters.

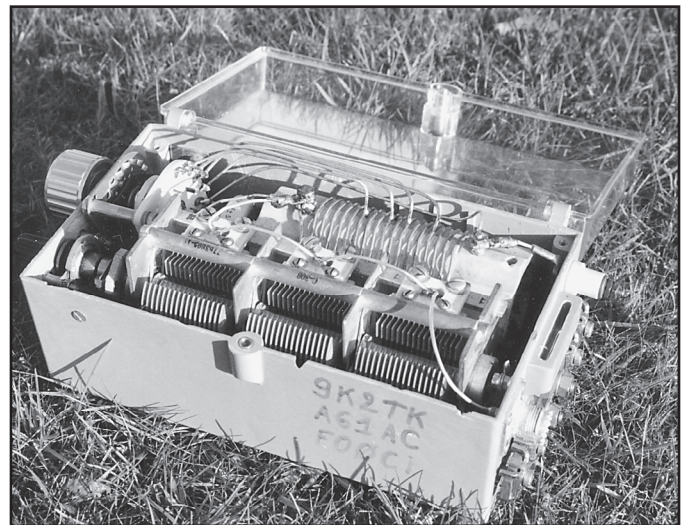

Fig 9-79—The L network of Fig 9-80 is contained in a small plastic housing. This particular unit was built by ON7TK and used on several DXpeditions (A61, 9K2, FO0C).



Fig 9-80—The wooden crate containing the Battle Creek Special antenna, a three-band (40, 80 and 160-meter) vertical. The wooden crate is especially designed to ensure safe transportation of the antenna to the most remote parts of the world. It contains all the antenna parts and accessories, such as guy ropes, anchors, hinged base plate, radial wires, etc.

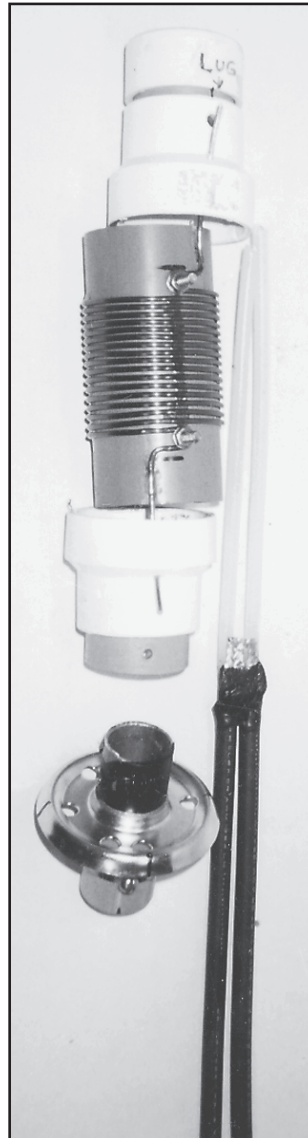

Fig 9-81—The new 80-meter trap for the Battle Creek Special. The original coaxial-cable traps have been replaced with regular LC traps, the capacitor being made by short pieces of coaxial cable. See text for details.

Fig 9-82 (below)—This version of the famous Battle Creek vertical is about 18 to 19 meters tall. If resonance on 80 cannot be achieved where wanted (if the support is not high enough), an 80-meter loading wire (typically 1 to 2 m long) can be added as shown. Slope this wire at right angle to the 40 and 160-meter loading wires if possible. The sloping angle of the 160-meter loading wire has a pronounced influence of the impedance of the antenna. You can use this to tune the antenna on 160. Keep the wire as horizontal as possible, however, it's better is to trim the length of the wire to tune it.

It is guyed four ways at three levels so the side guy ropes act as a hinge allowing it to be “walked up” by one person.

The original traps were coaxial-cable traps using RG-58, but they ran too hot with power levels over 800 W. Instead of changing to Teflon coax the designers decided to switch to regular L/C traps with the inductor made of #10 wire and the capacitor made from some lengths of RG-213 with 100 pF/m. The coaxial capacitors fit inside the aluminum mast sections. A single open-ended coax stub of about 90-cm length (90 pF) is used for the 40-meter trap and two parallel-connected pieces of coax of approximately 120-cm length each (240 pF total) are used for the 80-meter trap.

WØCD recommends using at least 30 radials, each of 20-meters length. I consider this a bare minimum. The Battle Creek Special is not for sale, but is available for loan to DXpeditions to rare countries. Interested and qualified DXpeditioners should contact W8UVZ for further details. The antenna was used at Bouvet on 80 and 160 meters in 1989/90, and during the DXpeditions to ZSØZ, 7P8EN, 7P8BH, G4FAM/3DA, 3Y5X, 5X4F, ZS8IR, XRØY, VP8SGP, YKØA, 8Q7AJ, VKØIR, ZS9Z, V51Z, P4ØGG, CY9AA, ZS6EX, ZS6NW, AHØ/AC8W, AL7EL/KH9, XF4DX, AH1A, 3YØPI,

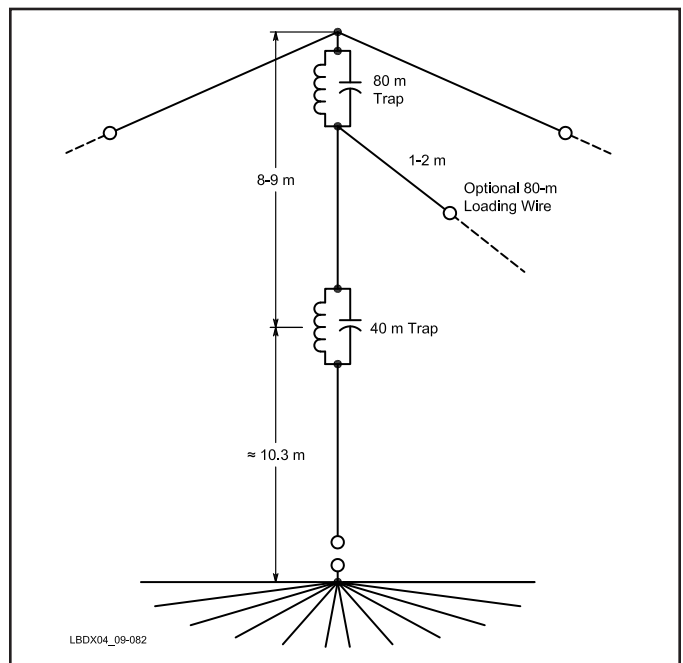

9M0C, J37XT, K5VT/JT, VK9LX, ZK1XXP, 3B7RF and many other locations with great success.

The entire antenna, with its base, guy-wires and radials is packed in a strong wooden case for safe transport to the remotest DXpedition spot. The package weighs 30 kg (66 lb). **Fig 9-80** shows the wooden crate containing the Battle Creek Special. **Fig 9-81** shows the 80-meter coax-cable trap.

For construction details, visit: www.ok1rr.com/view.php?cisloclanku=2004122518. A wire-type Battle Creek special vertical is shown in **Fig 9-82**.

6.7. A Very Attractive 160-Meter Vertical

Remember that a short vertical is as good as a full-size vertical if the losses in the system are zero. That means that your loading system has no losses (which means top loading). It also means that your ground losses are zero, which you can come close to if you use 100 $\lambda/4$ long radials or if you operate over saltwater. K7CA and N7JW developed such a vertical, which they both use in their 160-meter arrays (see Chapter 11), but which is very attractive as a single vertical as well. See **Fig 9-83**. The design set out to achieve $R_{rad} = 12.5 \Omega$, so that a simple $\lambda/4$ coax transformer can be used to match a 50- Ω feed line.

The vertical is 20-meters tall, and is made of aluminum tubing, top loaded with two in-line-sloping top hat wires, each approx 18 meters long and sloping at an angle of about 55°. The tips end up at a 10-meter height. This has a resonant frequency of 1830 kHz and the desired feed-point impedance of 12.5 Ω . All you need to do is use a 4:1 broadband transformer (2:1 turns ration on an appropriate ferrite core) to have a perfect 50- Ω match. This short antenna has a 2:1 SWR bandwidth of 60 kHz and a 1.5:1 SWR bandwidth of 40 kHz, more than decent!

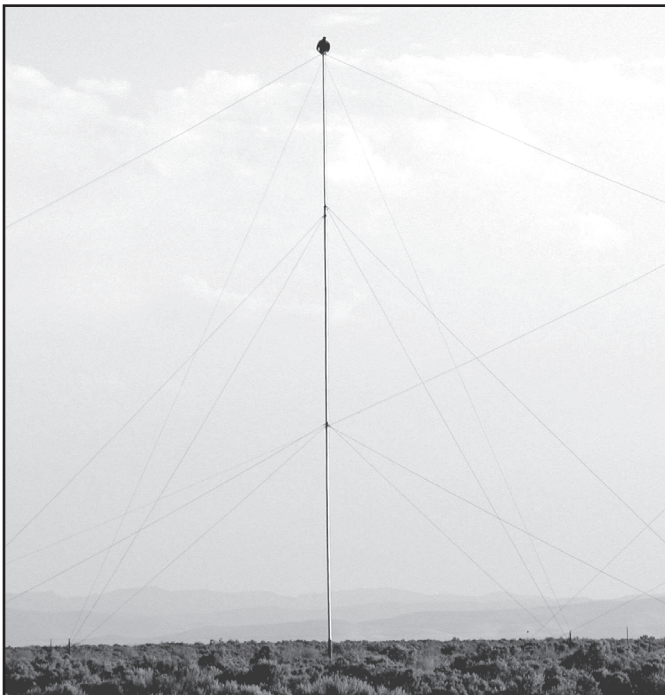

Fig 9-83—20-meter tall vertical with an eagle sitting on top in the desert location of N7JW’s remote-antenna setup in Southern Utah.

If you want play in the top league of the 160-meter DXers, make no compromises in your ground system! This is also the ultimate performer above saltwater, where just two elevated radials in a gull-wing configuration would do the job. This would be quite an attractive design for DXpeditions where the antenna can be set up over saltwater.

6.8. Using the Beam/Tower as a Low-Band Vertical

The tower supporting the HF antennas can often make a very good loaded vertical for 160 meters. A 24-meter tower with a triband or monoband Yagi, or a stack of Yagis, will exhibit an electrical length between 90° and 150° on 160 meters. These are lengths that are very attractive for low-angle work on 160.

6.8.1. The electrical length of a loaded tower

You can use **Fig 9-84** to determine the electrical length of a tower loaded with a Yagi antenna. The chart shows the situation for a tower with an effective diameter of 30 cm, loaded with five different types of Yagis, ranging from a 3-element, 20-meter Yagi to a 3-element 40-meter full-size Yagi. These figures are for Yagis that have their elements electrically connected to the boom, using so-called “plumber’s delight” construction. An antenna like a KT-34 will show little capacity loading, because all elements are insulated from the boom. More on this below.

A 24-meter tower, loaded with a 5-element, 20-meter Yagi, will have an electrical length of 103° on 1.825 MHz. The effect of capacitance top loading depends to a great extent on the diameter of the tower under the capacitance hat. The capacitance hat (the Yagis) will have a greater influence with “slim” towers than with large-diameter towers. If you increase the tower diameter to 60 cm, this will shorten the electrical length between 4° and 7° (4° for the tower loaded with the 3-element, 20-meter Yagi and 7° for the tower loaded with the

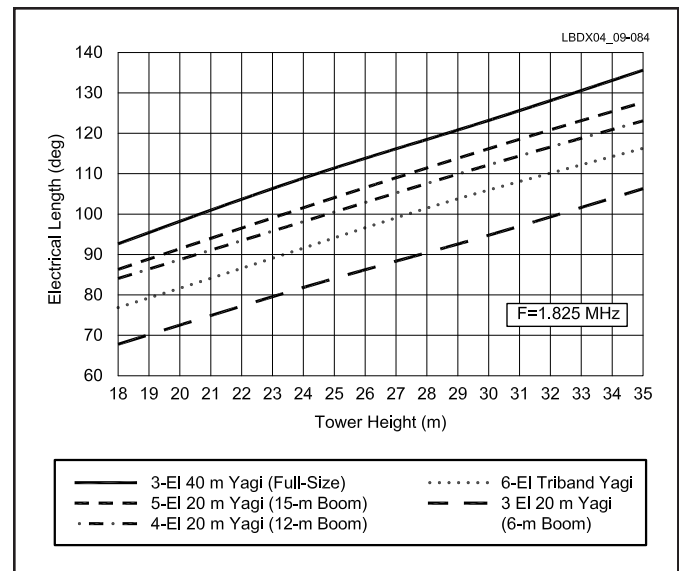

Fig 9-84—Electrical length of a tower loaded with a Yagi antenna. The chart is valid for 160 meters (1.825 MHz) and a tower equivalent diameter of 30 cm. For a larger tower diameter, the electrical length will be shorter (4° to 7° for a tower measuring 60 cm in diameter).

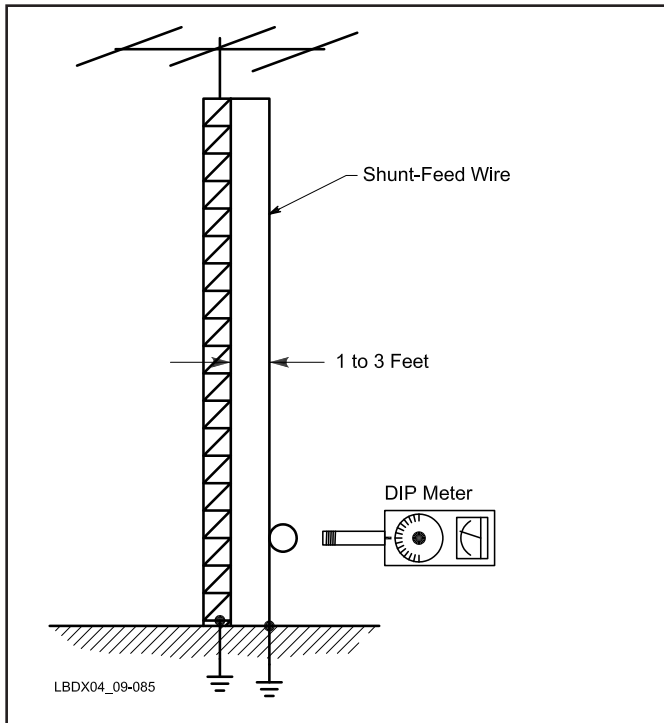

Fig 9-85—A method of “dipping” a tower with a shunt-feed wire connected to the top.

40-meter, 3-element full-size Yagi). W. J. Schultz, K3OQF, published the mathematical derivation of the shunt-fed top-loaded vertical (Ref 7995).

There are neither data nor formulas available for calculating the exact electrical length of a tower loaded with multiple Yagis. The best way to find out is to attach a drop wire to the very top of the tower (turn it into a folded element) and grid dip the entire structure, as shown in Fig 9-85. You could, of course, also model the entire structure, but that seems a rather tedious task.

If your tower, top loaded with a Yagi, is still a little short, you may want to add some extra wires from the top of the tower sloping down to increase the top loading. You might use part of the top set of guy wires, for example.

Towers with stacked Yagis are more difficult to assess. Basically it's the bottom Yagi that determines the capacity, as this Yagi *hides* the Yagis above it, especially if they are nearby and smaller.

6.9.2. Yagis with elements insulated from the boom

There are two problems associated with having Yagis with insulated elements on a tower for use on the lower bands:

- The insulated elements will only add little top loading
- Possible arcing of the Yagi insulating parts and destruction of baluns

Some Yagis use fiberglass or PVC for insulating their elements from the boom. While these are good enough for the Yagi, where the voltage between the center of the floating elements and the boom are low, voltages in case of a top-loaded tower may be very high in these same places. The highest RF voltage always occurs at the farthest end of an

antenna from the feed point. For a shunt-fed tower with an HF Yagi with insulated elements used for top loading this highest RF voltage point would be at the ends of the Yagi's boom (eg, the 20-meter reflector). In most cases you can simply ground the center of the elements to the boom.

PA3DZN had to do this with his KTX-34 tribander, and after having grounded all elements, he could not detect any change in performance of the Yagi, but his arcing problem was solved. John, K9DX, reported that he burned the feed line off his KLM 40-meter beam when it flashed over to the boom. Grounding all the elements solved the problem. Although direct grounding of the elements should in most cases not upset the functioning of the Yagi, you could connect the elements to the boom using RF inductors having a few hundred ohms reactance on the lowest band the Yagi is used on.

You should be careful grounding the center of the driven element, because that might upset the matching system. Although insulated from the boom, the driven element usually acts as if it were grounded to the boom on 160 meters because of the feed line's coupling to the tower on its way down to the ground. Therefore, the driven element already fully adds to the top-loading and there is no reason to “ground” the driven element to the boom when you shunt feed the tower on 160 meters.

Certain types of baluns used on Yagis can be destroyed by shunt feeding the tower. If you use a balun using ferrite material (eg, W2DU, Hy-Gain, or Force-12) you may have to decouple 160-meter RF from reaching the balun, which is not easily done at a high-impedance point, near the end of the 160-meter antenna (see also Section 6.8.8). Plumber's-delight Yagis (all elements connected to the boom and using a Gamma or Omega match) are the ideal solutions for Yagi-loaded towers.

6.8.3. Measuring the electrical length

A second and very practical method of determining the resonant length of a tower system was given by DeMaw, W1FB (Ref 774). A shunt-feed wire is dropped from the top of the tower to ground level. What you want to do is turn a grounded single-conductor vertical into a folded-element vertical, where you now can easily do measurements in the drop wire. Attach a small 2-turn loop between the end of the wire and ground and couple this loop to the grid dip meter (Fig 9-85).

The lowest dip found then is the resonant frequency of the tower/beam. The electrical length at the design frequency is given by:

$$L \text{ (in degrees)} = 90^\circ \frac{f_{\text{design}}}{f_{\text{resonant}}}$$

Therefore, if $f_{\text{resonant}} = 1.6 \text{ MHz}$ and $f_{\text{design}} = 1.8 \text{ MHz}$, then $L = 101^\circ$.

6.8.4. Gamma and omega matching

There are many approaches to matching a loaded, grounded tower. Three popular methods are:

- Slant-wire shunt feeding (Section 6.8.5)
- Folded-monopole feeding (Section 6.8.6)
- Gamma or omega-match shunt feeding.

Gamma and omega-matching techniques are widely used on loaded towers. The design of gamma matches has often

Table 9-8

Gamma-Match Data for a Shunt-Fed Tower with 50-cm Gamma-Wire Spacing

Tower electrical height = 100 degrees
 Tower diameter = 250 mm (10 inches)

	1.730	1.765	1.800	1.835	1.870	1.905	1.940 MHz
Gamma-wire diameter = 2 mm (AWG 12); tap height = 19.5 m (64.0 ft)							
R	80.6	66.8	56.5	50.0	43.3	39.2	36.0
X	+330	+338	+350	+363	+377	+392	+407
SWR	2.0	1.7	1.3	1.0	1.4	2.0	2.8
Gamma-wire diameter = 10 mm (0.4 in.); tap height = 19.8 m (65.0 ft)							
R	82.9	68.6	58	50	44.8	40.6	37.6
X	+250	+257	+267	+278	+291	+303	+316
SWR	1.9	1.6	1.3	1.0	1.3	1.8	2.4
Gamma-wire diameter = 50 mm (2 in.); tap height = 20.0 m (65.6 ft)							
R	80.8	66.9	56.9	50	44.3	40.3	37.3
X	+164	+171	+179	+188	+198	+208	+218
SWR	1.8	1.5	1.2	1.0	1.3	1.6	2.1
Gamma-wire diameter = 250 mm (10 in.); tap height = 20.2 m (66.3 ft)							
R	78.8	65.5	56	50	44	41	38.3
X	+75	+82	+90	+98	+105	+113	+121
SWR	1.8	1.5	1.2	1.0	1.2	1.5	1.8

been described in the literature (Ref 1401, 1414, 1421, 1426 and 1441).

Fig 9-86 shows the height of the gamma-match tap, as well as the value of the gamma capacitor for a range of antenna lengths varying from 60° to 180°. The chart was developed using a gamma wire of 10-mm diameter. There are three sets of graphs, for three different wire spacings (0.5, 1.0 and 1.5 meters).

It is a fairly common misconception to think that the tower must be resonant to be able to match it correctly to 50 Ω

at the desired frequency. This isn't true. However, there are some advantages to having the tower (with its top loading) resonant near the desired frequency:

- A resonant tower makes it possible to design an efficient shunt-feed system.
- A tower resonant slightly off the desired frequency can exhibit a broader SWR bandwidth because there are now two dips in the SWR curve, one caused by the resonant frequency of the tower and another one caused by the pulling of the Gamma or Omega match of the resonance to a slightly different frequency.
- The 50-Ω tap point is closest to the ground with a λ/4 resonant tower (only about 8 meters high on 160 meters).
- The 2:1 SWR bandwidth is better than with a non 1/4-wave shunt-fed vertical (see also Section 6.8.4.3).
- The RF voltage across the gamma capacitor will be lowest.

However, it is not necessary to strive for λ/4-wave resonance. Virtually any size vertical can be successfully shunt-fed and will perform well.

6.8.4.1. Close spacing versus wide gamma spacing

The wider the spacing, the shorter the gamma wire needs to be. Shorter gamma wires will naturally show less inductive reactance, which means that the series capacitor must be larger in value.

Electrically very long verticals will require a tap that is 20 to 30 meters up on the tower. The required series capacitor will be small in value (typically 100 to 150 pF). There will be a very high voltage across capacitors of such small value.

In case the required gamma-wire length shown in Fig 9-85 appears to be longer than the physical length of the tower, you will need an omega match (see Section 6.8.4).

6.8.4.2. Influence of gamma-wire diameter

The gamma-wire diameter has little influence on the

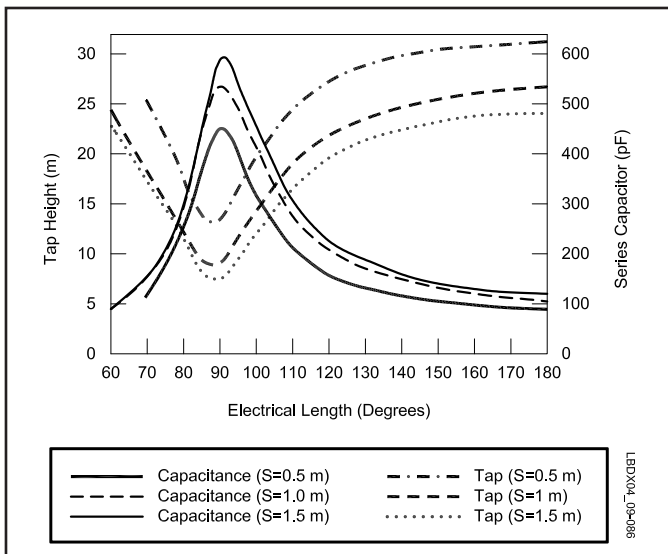

Fig 9-86—Tap height and values of the gamma series capacitor for a shunt-fed tower at 1.835 MHz. The tower diameter is 250 mm, and the gamma wire has a diameter of 10 mm. Three sets of curves are shown, for three spacings (S). The spacing is the distance from the wire to the tower center.

Table 9-9**Gamma-Match Data for a Shunt-Fed Tower with 150-cm Gamma-Wire Spacing***Tower electrical height = 100 degrees**Tower diameter = 250 mm (10 inches)*

	1.730	1.765	1.800	1.835	1.870	1.905	1.940 MHz
Gamma-wire diameter = 2 mm (AWG 12); tap height = 11.9 m (39.0 ft)							
R	86.8	71	59	50	43.7	38.8	35
X	+226	+229	+236	+244	+253	+262	+272
SWR	1.8	1.5	1.2	1.0	1.2	1.6	2.1
Gamma-wire diameter = 10 mm (0.4 in.); tap height = 12.0 m (39.4 ft)							
R	87.8	71.7	59.8	50	44.4	39.5	25.7
X	+179	+181	+187	+195	+203	+212	+220
SWR	1.8	1.5	1.3	1.0	1.2	1.6	2.0
Gamma-wire diameter = 50 mm (2 in.); tap height = 12.0 m (39.4 ft)							
R	87	71	59	50	44.3	39.5	35.8
X	+120	+132	+137	+144	+152	+159	+166
SWR	1.8	1.5	1.2	1.0	1.2	1.5	1.8
Gamma-wire diameter = 250 mm (10 in.); tap height = 11.9 m (39.0 ft)							
R	85.2	69.6	58.3	50	44	39.4	36
X	+79	+82	+87	+93	+100	+1-6	+112
SWR	1.8	1.5	1.2	1.0	1.2	1.5	1.7

length of the gamma wire (position of the tap on the tower). A larger diameter wire will require a somewhat shorter gamma wire. The wire diameter has a pronounced influence, however, on the required gamma capacitor. It also has some influence on the SWR bandwidth of the antenna system, but less than most believe.

6.8.4.3. SWR bandwidth

Tables 9-8 and 9-9 show the feed-point impedance and the SWR versus frequency for a vertical of 100° electrical length, fed with a gamma match. A spacing of 50 cm is used in Table 9-8, and 150-cm spacing in Table 9-9. Wire diameters of 2 mm (AWG #12), 10 mm, 50 mm and 250 mm are included. The 2-mm (#12) wire is certainly not responsible for a narrow bandwidth. It does not seem worth using a “wire cage” gamma-wire to improve the bandwidth.

For loaded towers that are much longer than 100°, the bandwidth behavior is quite different. The longer the electri-

cal length of the vertical, the narrower the SWR bandwidth. Table 9-10 shows the feed-point impedance and the SWR for a vertical of 150° electrical length, fed with a gamma-match and a gamma-wire of both 10 mm and 250 mm OD. In contrast with the effect on the shorter vertical (100°), the wire diameter now has a pronounced influence on the bandwidth. The 10-mm wire yields a 70-kHz bandwidth; the 250-mm wire cage almost 130 kHz. As can be seen from the impedance values listed in Table 9-9, it is the large variation in reactance that is responsible for the steep SWR response. This can be overcome using a motor-driven variable capacitor. The 150° long antenna with a 10-mm-OD gamma wire shows an SWR of less than 1.3:1 over more than 200 kHz, if a variable capacitor with a tuning range of 100 to 175 pF is used. A high-voltage (eg, 10 kV) vacuum variable is a must.

This simple way of obtaining a very flat SWR does not apply to shorter verticals (90° to 110°), where a much larger variation in the resistive part of the feed-point impedance is

Table 9-10**Gamma-Match Data for a Shunt-Fed Tower with 150-cm Gamma-Wire Spacing***Tower electrical height = 150 degrees**Tower diameter = 250 mm (10 inches)*

	1.730	1.765	1.800	1.835	1.870	1.905	1.940 MHz
Gamma-wire diameter = 102 mm (0.4 in.); tap height = 25.9 m (65.0 ft)							
R	43.1	45.2	47.7	50	54	58	62.7
X	+567	+597	+628	+661	+697	+736	+778
SWR	6.0	3.5	1.9	1.0	2.0	3.7	6.3
Gamma-wire diameter = 250 mm (10 in.); tap height = 24.8 m (81.4 ft)							
R	41.5	43.8	46.6	50	54	58.5	64
X	+286	+303	+320	+340	+362	+384	+409
SWR	3.2	2.2	1.5	1.0	1.5	2.2	3.2

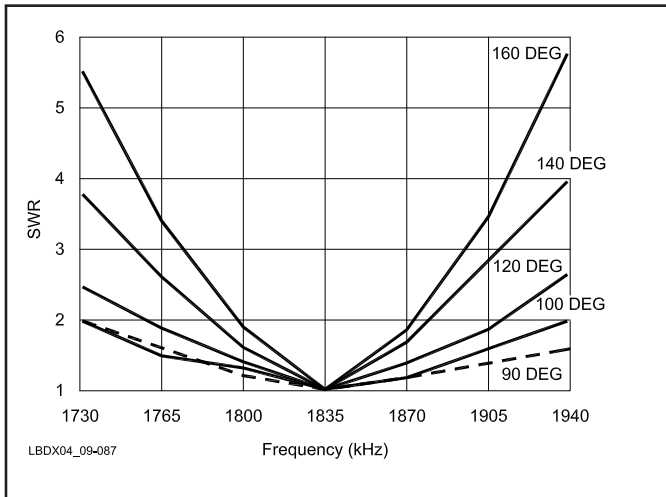

Fig 9-87—SWR curves for gamma-fed towers using a 10-mm OD gamma wire and a spacing of 50 cm, for electrical tower lengths varying from 90° to 160°. The SWR of the longer vertical can be tuned over a wide bandwidth using a motor-driven variable series capacitor.

responsible for the SWR. Fig 9-87 shows SWR plots for gamma-fed towers of varying electrical length, using a 10-mm OD gamma wire, spaced 150 cm from the tower.

6.8.4.4. Adjusting the gamma-matching system

The easiest way to fine tune the gamma-matching system is to vary the spacing of the gamma wire. This changes the resistive part of the feed-point impedance. Then you can tune out the inductive reactance using the series Gamma capacitor for a 1:1 SWR.

Example:

For a vertical 100° electrical long and with a tower diameter of 250 mm, we install the tap at 14 meters. At that point the spacing is 1 meters. Changing the spacing to ground

level has the following influence:

- Spacing = 0.5 meters: $Z = 38 + j 206 \Omega$
- Spacing = 0.75 meters: $Z = 44.8 + j 298 \Omega$
- Spacing = 1.0 meters: $Z = 49.3 + j 211 \Omega$
- Spacing = 1.25 meters: $Z = 56.4 + j 213 \Omega$
- Spacing = 1.5 meters: $Z = 61.5 + j 214 \Omega$

This demonstrates how fine tuning can easily be done on the gamma-matching system.

6.8.4.5. Using the omega matching system

If you can tune your tower using a gamma, I would not advise using an omega system. The omega match requires one more component, which means additional losses and additional chances for a component breakdown. It is possible, however, to use a gamma-rod (wire) length that is up to 50% shorter than the length shown in Fig 9-86 when you use an omega match. An Omega system is similar to a Gamma system except that a parallel capacitor is connected between the bottom end of the gamma wire and ground.

The 100°-long vertical requires a 14-meter long gamma wire, with 100-cm gamma-wire (OD 10 mm) spacing. If we shorten the gamma wire to 8 meters, the transformed impedance becomes $14.1 + j 127 \Omega$. This can be matched to 50Ω using an L network. One of the solutions of this L network consists of two capacitors: the well-known parallel and series capacitor of the omega-matching system. To calculate the omega-system, use the following procedure:

- Model the vertical with the shorter gamma rod. Make sure you use enough segments (pulses). For 160 meters, segment lengths of 100 cm gives good results. Note the input impedance, which will be lower than 50Ω and inductive.
- Use the L NETWORK module of the NEW LOW BAND SOFTWARE to calculate the capacitance of the parallel and the series capacitor.

In our example above, the 8-meter-long gamma wire requires a parallel capacitor of 369 pF and a series capacitor of 323 pF.

**Table 9-11
Omega-Match Data for a Shunt-Fed Tower with 50-cm Gamma-Wire Spacing**

Tower electrical height = 140 degrees
Tower diameter = 250 mm (10 in.)

	1.730	1.765	1.800	1.835	1.870	1.905	1.940 MHz
Gamma-wire diameter = 2 mm (AWG 12); tap height = 24.0 m (78.7 ft)							
R	16.0	16.3	16.7	17.2	17.9	18.6	19.3
X	+514	+535	+552	+579	+603	+629	+650
With parallel capacitor of 62 pF added							
R	37.4	40.7	44.8	50	56.8	65.3	74.7
X	+785	+845	+910	+986	+1073	+1178	+1287
With fixed series capacitor of 88 pF added							
R	37.4	40.7	44.8	50	56.8	65.3	74.7
X	-261	-180	-95	0	+106	+228	+348
SWR	38.0	17.9	5.9	1.0	5.8	17.9	35
With variable series capacitor, 50 to 125 pF (adjusted to cancel inductive reactance)							
R	37.4	40.7	44.8	50	56.8	65.3	74.7
X	0	0	0	0	0	0	0
SWR	1.3	1.2	1.1	1.0	1.1	1.3	1.5

If you have a physically short tower with a lot of loading, it may be that the required tap height is greater than your tower height. In this case an omega match is the only solution (if you have already tried a larger spacing).

Example:

See Fig 9-89. The tower was grid-dipped and the electrical length turned out to be 140° . The physical height is 24 meters. Fig 9-86 shows a required gamma-wire length of 30 m for a 2-mm OD gamma wire and a 50-cm spacing. In this case we will connect the gamma wire at the top of the tower (h = 24 meters). Using NEC-2, we calculate the feed-point impedance as $Z = 17.2 + j 579 \Omega$. From the L NETWORK software module, the capacitor values are calculated as $C_{par} = 62 \text{ pF}$, $C_{series} = 88 \text{ pF}$. Note that these very low-value capacitors will carry very high voltages across their terminals with high power.

This L network is a high-Q network. Table 9-10 lists the impedances at the end of the gamma wire before and after transformation by the capacitors of the omega-match. Note the very narrow bandwidth of this high-Q matching system. If we adjust the omega-capacitors for a 1:1 SWR on 1835 kHz, the 2:1 bandwidth will be typically only 20 kHz. If we make the series capacitor adjustable (60 to 120 pF), we can tune the antenna to an SWR of less than 1.5:1 over more than 200 kHz.

6.8.4.6. Conclusion

If after modeling or actually measuring your loaded tower it turns out to be longer than about 140° , you might consider using an elevated feed system, with lots of elevated radials (see Section 2.2.10). Within reason, the longer the section below the feed point, the easier to decouple this section. If you keep raising the base of the vertical, however, you will achieve a vertical radiation pattern that is not ideal for most DX work.

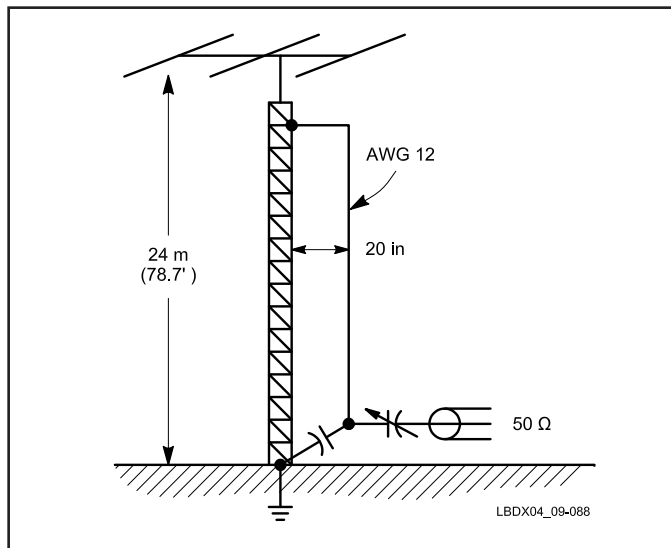

Fig 9-88—A shunt-fed tower using an omega matching system. The tower is electrically 140° long. An omega match is required, since the tower is physically too short to accommodate a gamma match with a 2-mm gamma wire. Table 9-11 lists the impedances at the end of the gamma wire before and after transformation by the capacitors of the omega-match system.

If you have an electrically long gamma-matched vertical (more than about 110° high), you can use a large-diameter cage-type gamma wire and a large wire-to-tower spacing. Making the series capacitor remotely tunable will certainly make the antenna much more broadband. Do not shorten the gamma wire unless required because of the physical length of the tower.

Fig 9-89 shows the correct wiring of both the gamma and omega-matching networks on a loaded tower. Notice the correct connection of the shunt capacitor in the case of the omega match. Make sure the ground wires all have very low resistance and the lowest possible reactance. Use flat solid-copper strip if possible. Do *not* use flat braided strip, which has high RF losses, contrary to popular belief.

The same principles can, of course, be applied to 80 meters, although it is probable that a tower of reasonable height, loaded with a Yagi antenna, will result in too long an antenna for operation on that band.

6.8.4.7. A few practical hints

All cables leading to the tower and up to the rotator and antennas should be firmly secured to a tower leg, on the inside of

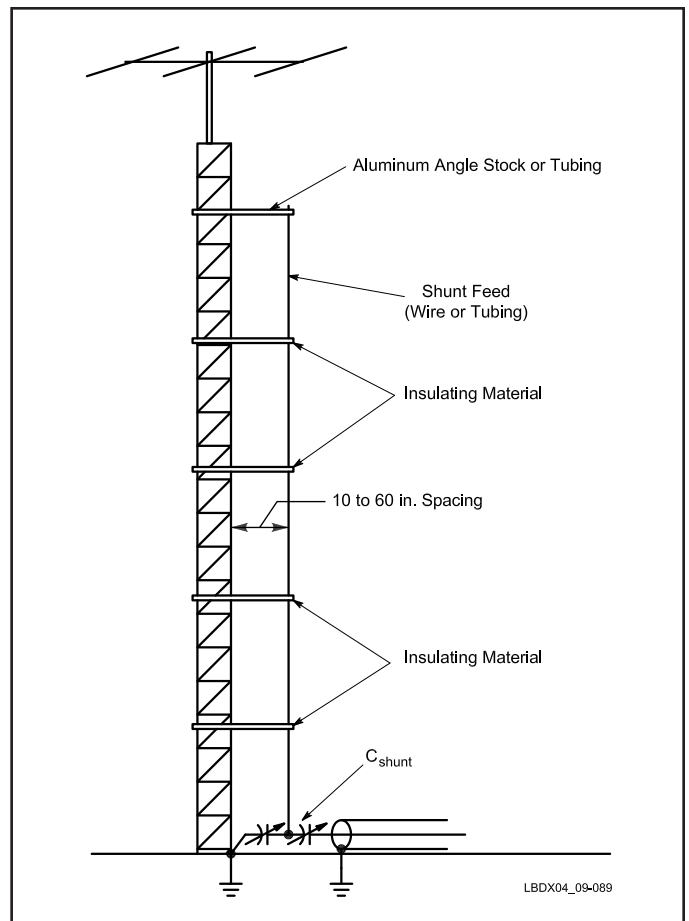

Fig 9-89—The omega-matching system (a gamma match with an additional shunt capacitor) adds a great deal of flexibility to the shunt-fed-tower arrangement. To maintain maximum bandwidth make the gamma wire as long as possible. If the antenna is electrically longer than 120° , a variable series capacitor will make it possible to obtain a very low SWR over a wide bandwidth.

the tower. All leads from the shack to the tower base should be buried underground to provide sufficient RF decoupling. If there is RF on some of the cables, you should coil up a length of the cable running up your shunt-fed or series-fed tower to make a common-mode choke at the tower base. A coil consisting of 50 turns on a 10-cm diameter form yields about 100 μH of inductance. If you still detect some RF on these cables entering your shack, install another coil at that point or put some ferrite beads on the cable. Coaxial cables running down the tower should preferably be grounded right at the base of the vertical.

Take care to ensure good electrical continuity between the tower sections, and between the rotator, the mast and the tower. Again, use flat-strip copper conductors, not the woven battery-connecting flat strips, which are good only for dc.

A gamma rod can be supported with sections of plastic pipe, attached to the tower with U bolts or stainless-steel radiator hose clamps. If the tower is a crank-up type, heavy, insulated copper wire can be used for the gamma element.

6.8.5. The slant-wire feed system

The slant-wire feed system is very similar to a gamma feed system. The feed wire is attached at a certain height on the tower and slopes at an angle to the ground, where a series capacitor tunes out the reactance. The advantage of this system is that a match can be obtained with a lower tap point, which makes it possible to avoid using an omega match on physically short towers. The disadvantage is that the slant-wire feed also radiates a horizontally polarized component. The slant-wire feed system can easily be modeled using a computer program, just like the gamma and omega-matching systems.

6.8.6. Folded monopoles

Folded antennas have the following advantages:

- Higher bandwidth due to a larger effective antenna diameter
- Higher feed-point impedance.

Fig 9-90 shows how you can manipulate the wire diameter and spacing to obtain up-transformation ratios ranging from two to well over 10. (Source: *Kurze Antennen*, by Gerd

Janzen, ISBN 3-440-05469-1). The configuration of the two-wire folded monopole is shown in the same figure. One leg is grounded, while the antenna is fed between the bottom of the other leg and ground.

The effective diameter of multi-wire elements can be calculated from the chart shown in Fig 9-50. Three-wire folded-element configurations allow even higher transformation ratios, as can be seen in **Fig 9-91**. The effective antenna diameter (which determines the bandwidth of the antenna) is given in Fig 9-64 for the various configurations. The configurations are also shown in the same figure.

6.8.7 Modeling shunt-fed towers

MININEC or *NEC-2* can be used for modeling the gamma, omega and slant-wire matching systems on shunt-fed grounded towers. Satisfactory results are obtained using the following guidelines:

- The horizontal wire connecting the gamma wire to the tower has one segment (the length of the segment is the spacing from the gamma wire to the tower).
- Use approximately the same segment lengths on all wires of the antenna.
- All segments should have the same length; this is determined by the length of the horizontal wire connecting the gamma-wire to the tower.
- Do not try to model the capacitance top load. It is much easier to first grid-dip the tower (see Fig 9-85), calculate the electrical length of the loaded tower and then use an equivalent straight tower to do the gamma-match modeling.

Example:

A tower dips at 1.42 MHz. The required operating frequency is 1.835 MHz. The electrical length is:

$$L \text{ (in degrees)} = 90^\circ \frac{1.835}{1.42} = 116^\circ$$

The physical length of a $\lambda/4$ tower (equivalent diameter = 250 mm) is 39 meters. The equivalent tower length for 116° is:

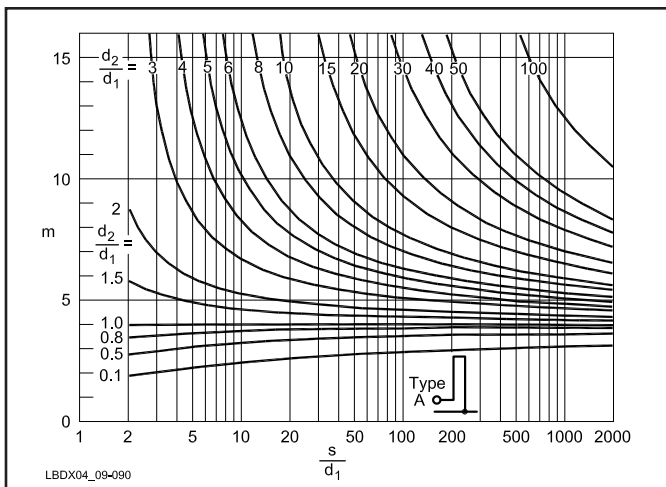

Fig 9-90—Transformation ratio (m) of a two-wire folded monopole, as function of the wire spacing (S/d_1) and the ratio of the conductor diameter ($d_2 =$ diameter of the grounded conductor, $d_1 =$ diameter of the fed conductor). (After Gerd Janzen, *Kurze Antennen*.)

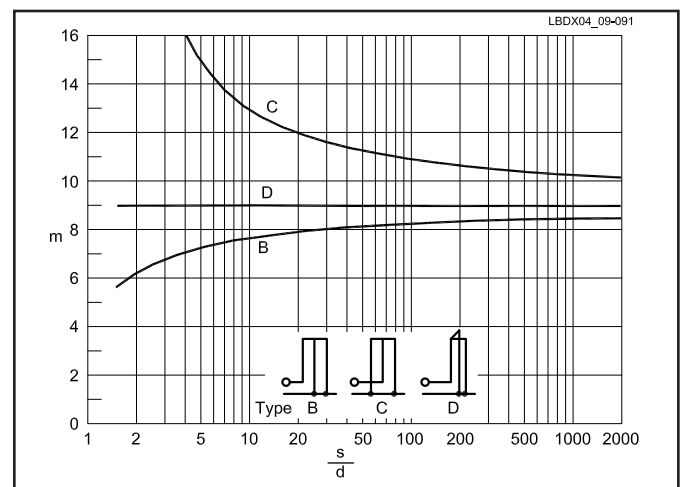

Fig 9-91—Transformation ratio (m) of a three-wire folded monopole, as function of the spacing between the wire (S/d) and the configuration B, C or D). In this case three conductors of equal diameter are assumed. (After Gerd Janzen, *Kurze Antennen*.)

$$39\text{m} \times \frac{116^\circ}{90^\circ} = 50.3 \text{ meters}$$

Now model a vertical with a diameter of 250 mm and of 50.3 meters length. According to Fig 9-86, the tap will be at a height of between 17 and 25 meters, depending on the wire spacing.

6.8.8. Decoupling antennas at high-impedance points

When shunt feeding a tower that supports various antennas, including wire antennas, you may wish to decouple the wire antennas from the vertical radiator. Otherwise, the wire antennas will act as top loading to the vertical. For relatively short towers, the extra loading may be welcome, but in other cases the loaded vertical may become too long with the additional loading of large wire antennas, such as a 160-meter or an 80-meter inverted V.

These wire antennas are usually installed at the top of the tower, at a high-impedance point. This makes decoupling of the wire antennas more difficult. Conventional common-mode current baluns are not suitable, since they do not have enough inductance to effectively decouple the antenna. Such baluns can lead to unexpected changes in the feed-point impedance of the loaded vertical while transmitting. When first transmitting the SWR may be normal, but soon the ferrite material used in the current balun will heat to the point where the Curie temperature is reached, resulting in a sudden drop in magnetic susceptibility of the ferrite material. The balun will no longer represent enough impedance, causing the dipole to load the tower with a change in SWR as a result.

For effective decoupling in this application, a high-impedance balun is required. This balun is rather like a trap—a parallel-tuned resonant circuit—tuned to the frequency of the loaded vertical. The RF currents that flow from the vertical to the dipole (which we want to decouple) are common-mode currents, which means they flow only on the outside of the coaxial feed line of the inverted V dipole.

The trap is made by winding a single-layer coil of coax onto a suitable form, and resonating the coil with a suitable capacitor. Jim Jorgenson, K9RJ, made such a trap for 160 meters. It consisted of 21 turns of RG-213, wound close spaced on a PVC pipe 10-cm in diameter. The coil is about 33 cm long, and the measured inductance of this coil is 33 μH . The coil is held in place on the form by drilling close-fitting holes at an angle through the PVC pipe and passing the coax through these holes into the interior of the pipe at both ends. At one end the shield and the inner connector are separated and connected to stainless steel eyebolts that are used to connect the two legs of the inverted V antenna. At the other (bottom) end the coax passes out through a standard PVC end cap and a PL-259 connector is attached at that end.

The capacitance needed to resonate this coil on 1830 kHz is about 200 pF. You could use a quality transmitting-type ceramic capacitor, but a suitable capacitor can be made from a short piece of coax. RG-213 coax has a capacitance of 100 pF/m, which means that an open-ended piece of RG-213, 2 meters long will resonate the coil on 160 meters. The resonant frequency of the trap can easily be measured using a grid-dip meter. Fig 9-92 shows the layout of the trap and Fig 9-93 shows it deployed on the tower. To tune the trap, you can deliberately make the coaxial-line capacitor too

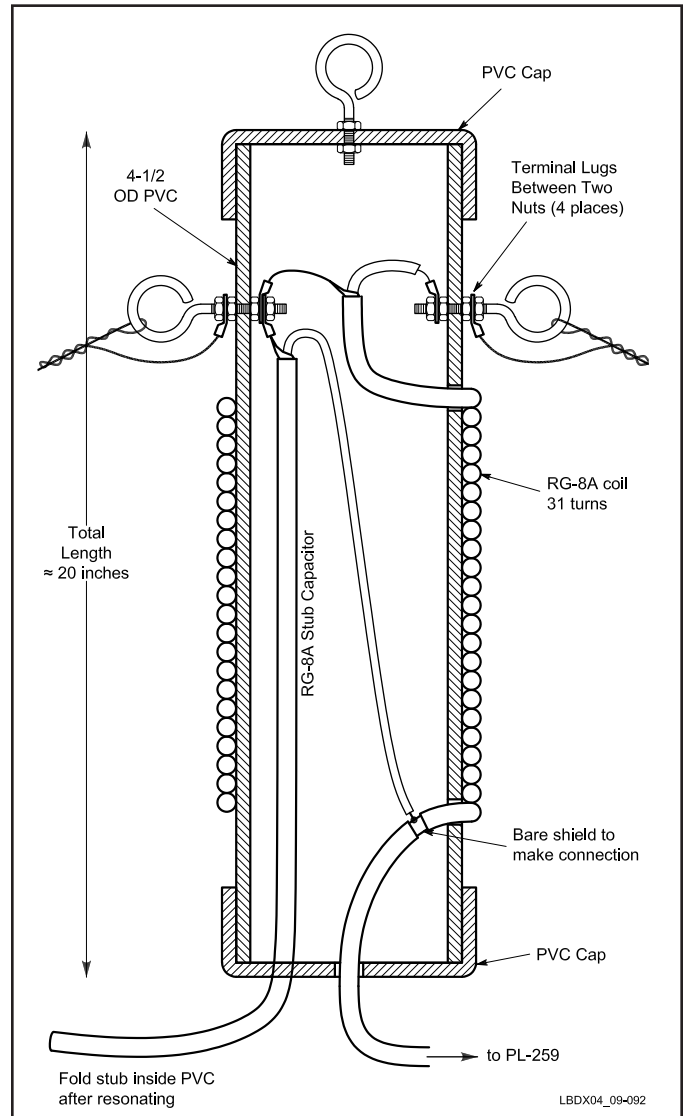

Fig 9-92—Construction details of the K9RJ decoupling trap.



Fig 9-93—The K9RJ coaxial trap feeds a 160-meter inverted V hanging from the top of a tower, which is also used as a shunt-fed vertical for 160 meters. The entire construction looks somewhat like an oversized center insulator or balun.

long, and then cut small pieces at a time until resonance is obtained at the desired frequency. The stub capacitor can then be folded inside the PVC tube before putting on the bottom end cap. Jim reports that since he has been using this balun there has been no change of the shunt-fed tower impedance, with the 160-meter inverted V attached. This proves that the trap is now fully decoupling the inverted V from the vertical.

Whether or not this concept is good enough to decouple the inverted V-antenna (in this case) from the tower depends on where along the tower this system is installed. If it is installed right at the top of the tower with no additional top loading, the impedance at that point is very high, meaning extremely high voltages at that point. This system worked for a 160-meter inverted-V mounted at the 80-foot level on K9RJ's 100-foot shunt-fed and top-loaded tower. It probably would work well enough for most typical shunt-fed and top-loaded tower installations on 160 meters, but not when the antenna is installed right at the top of an unloaded tower.

7. INVERTED-L ANTENNAS

The ever-so popular inverted-L is analyzed in this section and a few practical designs, such as the well-known "AKI

Special," are given particular attention.

The inverted L is a popular antenna, especially on 160 meters. These antennas are not truly verticals, as part of the antenna is horizontal and thus radiates a horizontally polarized component. We often form the wrong mental picture of what actually happens because most antenna modeling programs only express the field in two distinct polarizations. We wrongly picture two distinct fields. The actual field is the vector sum of the two fields, and is a single polarization wave with a tilt and a distinct total null at 90-degrees from the peak response.

Most inverted Ls are of the $\lambda/4$ variety, although this does not necessarily need to be the case. The vertical portion of an inverted L can be put up alongside a tower supporting HF antennas. In such a setup one must take care that the tower plus HF antenna does not resonate near the design frequency of the inverted L. Grid dip your supporting tower using the method shown in Fig 9-85. If it dips anywhere near the operating frequency, maybe you should shunt feed the tower instead of using it as a support for an inverted L.

If you choose to do the inverted L, you can detune the tower to make sure the highest possible current flows in the parallel-tuned structure (see Section 3.10 in Chapter 7).

The longer the vertical part of the antenna, the better the low-angle radiation characteristics of the antenna and the higher the radiation resistance (see Fig 9-94). The horizontal

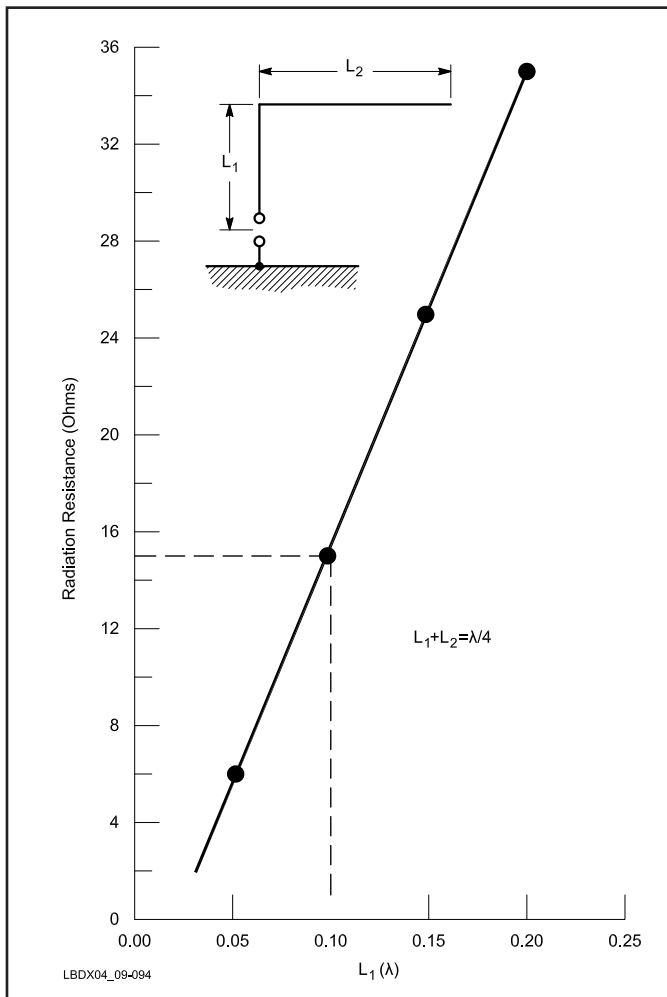

Fig 9-94—Radiation resistance of an inverted-L antenna as a function of the lengths of the horizontal wire versus the vertical conductor size.

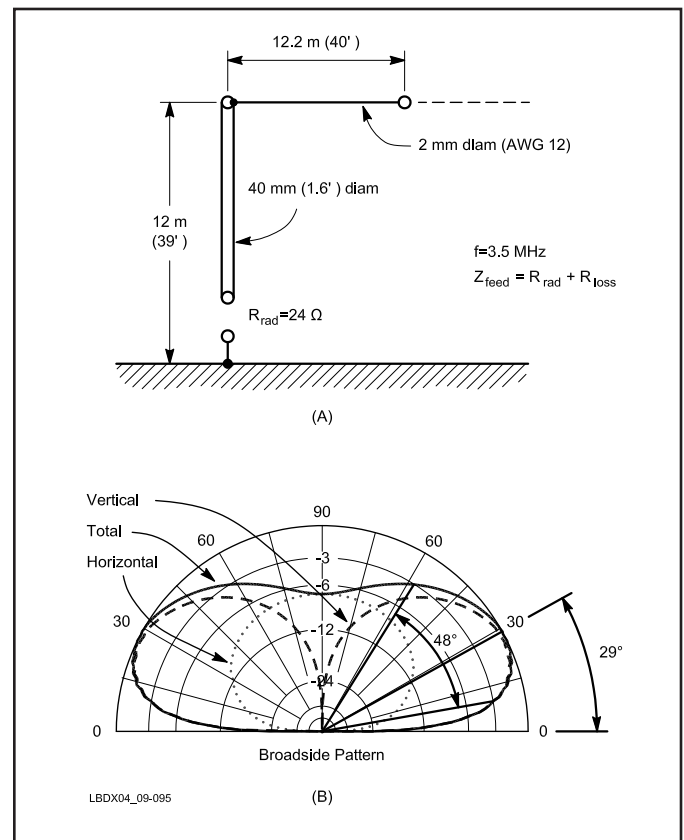

Fig 9-95—At A, a 3.5-MHz inverted L with a 12-meter vertical mast. The vertical radiation pattern is shown at B. The pattern has both vertically and horizontally polarized components and these components are also plotted at B. The pattern is generated over average ground, using 60 $\lambda/4$ radials. Note that the angle of maximum radiation is 29°, not bad for a DX antenna.

part of the antenna accounts for the high-angle radiation that the antenna produces but this normally is low, since the bulk of the radiation comes from the bottom part of the antenna, where the current is highest. Since it is a top-loaded monopole, an inverted L still requires a good ground system.

Fig 9-95 shows the vertical and horizontal radiation patterns for a practical design of an inverted-L antenna for 3.5 MHz, one having a 12-meter vertical mast. Notice how the vertical part of the antenna takes care of the low-angle radiation, while the horizontal part gives high-angle output. The radiation pattern shown is for the direction perpendicular to the plane of the inverted L.

An inverted L is also an attractive solution for the operator

who wants to use an 80-meter vertical antenna as a support for a 160-meter antenna (**Fig 9-96A**). The easiest solution is to insert a trap at the top of the 80-meter vertical. The exact L/C ratio is not important, but it influences the length of the loading wire and the SWR behavior of the antenna on both 80 and 160 meters. See also Figs 9-71 and 9-73.

A second alternative, shown in Fig 9-96B, uses an 80-meter trap to isolate the horizontal part of the 160-meter inverted-L antenna when operating on 80 meters (Ref 659). The trap can be a coaxial-cable trap as explained in Section 6.4.

The inverted L has been extensively described in amateur literature as a good antenna for producing a low-angle signal on Topband (Ref 798 and 7994). The Battle Creek Special, described in Section 6.6 is an example of an inverted L (on 80 and 160 meters).

7.1. The AKI Special

The AKI Special is another DXpedition-style inverted L, as used by Aki Nago, JA5DQH, during his operations on 160 meters from several rare DX spots. From Kingman Reef (May 1988), Nago used the inverted L shown in **Fig 9-97**. The vertical part is made of a 12-meter aluminum mast, which is extended by an 8-meter-long fiberglass fishing rod, to which a

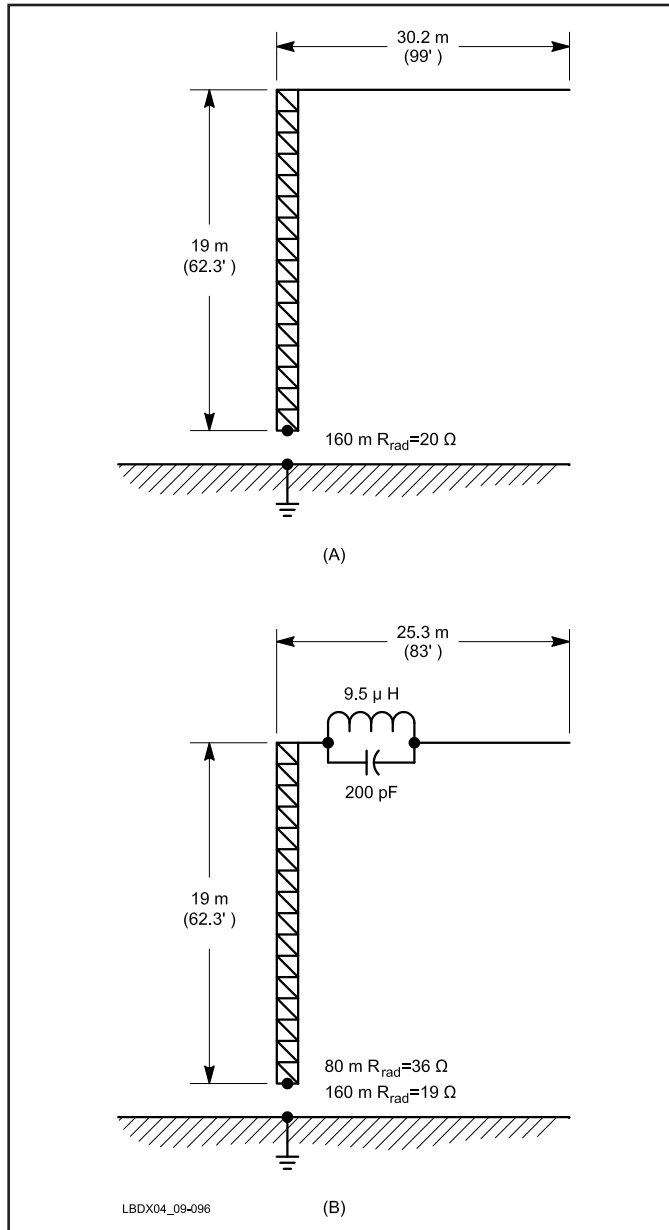

Fig 9-96—At A, an inverted-L antenna for 160 meters, using a 19-meter vertical tower. To cover both 80 and 160 meters, a trap can be installed at the top of the tower as shown at B. With the trap installed, the loading wire is shorter, because the trap shows a positive reactance (loading effect) on 160 meters. See also Figs 9-71 and 9-73.

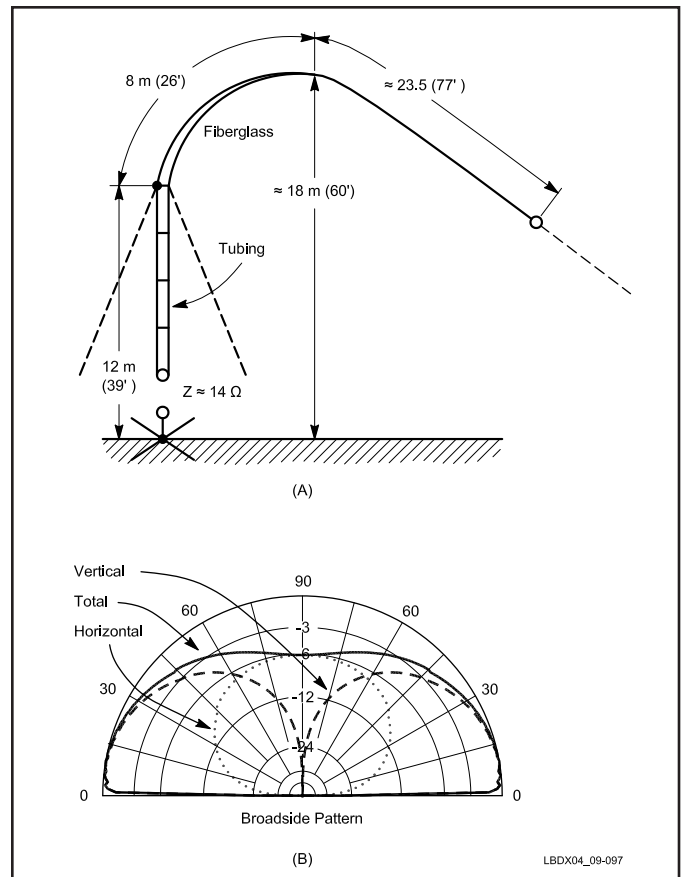

Fig 9-97—The “AKI Special,” a typical DXpedition type 160-meter inverted L. A collapsible fiberglass fishing rod (available in Europe in lengths of up to 12 meters) is used on top of a 12-meter aluminum mast. A #12 wire is attached to the rod, and slopes to a distant point to make the sloping (horizontal) part of the antenna. The radiation pattern is over saltwater. (That’s where the island DXpeditioners put these antennas.)

copper wire has been attached. From the tip of the (bent) fishing rod, the sloping wire extends another 23.5 meters, to be terminated with a fishing line supported by a 3-meter pole at some distance. Aki used about 800 meters of radials running into the Pacific Ocean. He used a very similar 160-meter antenna successfully from Palmyra during the same DXpedition trip in 1988, and during a more recent DXpedition to Ogasawara by JA5AUC. The excellent signals from VKØIR (1996) on 80-meter SSB were also produced with an AKI-type inverted L, using two elevated radials, above a large number of ground wires (not connected to the radials or the feed system). The calculated radiation resistance of this antenna is approximately 14Ω . The main radiation angle (over sea water) is 10° , but due to the relatively long horizontal (sloping) wire, the radiation at higher angles is only slightly suppressed.

7.1.1. Tuning procedure

When cutting the length of the sloping wire, cut it at first 2 meters too long. Put up the antenna, and connect one of the popular antenna analyzers (MFJ, AEA or Autek) between the bottom of the antenna and the ground system. Adjust the length of the sloping top wire for minimum SWR. Now read the resistance value off the scale of your analyzer. If it is between 35Ω and 70Ω , the SWR will be pretty acceptable (1.5:1) and you may want to feed the antenna directly with 50- Ω feed line. From the difference between the R value and the calculated 14- Ω radiation resistance, you can calculate the effective ground-loss resistance of the ground radial system. If the feed-point impedance is above 50Ω , you really need to improve the radial system. At 50Ω the efficiency would be $14/50 = 28\%$. Any value higher than 50Ω indicates an even lower efficiency. If you want a perfect match you can use an L network or an unun (Ref 1522).

8. THE T ANTENNA

The current-fed T antenna is a top-loaded short vertical, as covered earlier in this chapter. The voltage-fed T antenna is given special attention here, as well as different top-loading structures.

8.1. Current-Fed T Antennas

T-wire loading (flat-top wire) is covered in detail in Sections 3.6.4 and 3.6.5 when dealing with top loading of short verticals. The advantage of the horizontal T-wire loading system over the inverted-L system is that the top-wire does not contribute to the total radiation pattern. **Fig 9-98** shows a practical current-fed T design, where a 12-meter long vertical is loaded with a horizontal top-load wire to achieve resonance at 3.5 MHz. The R_{rad} of this design is approximately 23.5Ω .

Fig 9-55 gives a design chart for $\lambda/4$ T antennas. If there is not enough room for a single flat-top wire, two wires (or any number of wires positioned in equal increments on a 360° circle) can be used. If you use two in-line wires the length of the wire will be about 60% of the length of a single wire.

8.2. Voltage-Fed T Antennas

Voltage-fed T antennas are loaded vertical antennas with a current minimum at ground level. A specific case consists of a quarter-wave vertical, loaded with a half-wave top wire. **Fig 9-99** shows the configuration of this antenna and the current distribution. In this case, the impedance at the base of the antenna is high and purely resistive. The current maximum

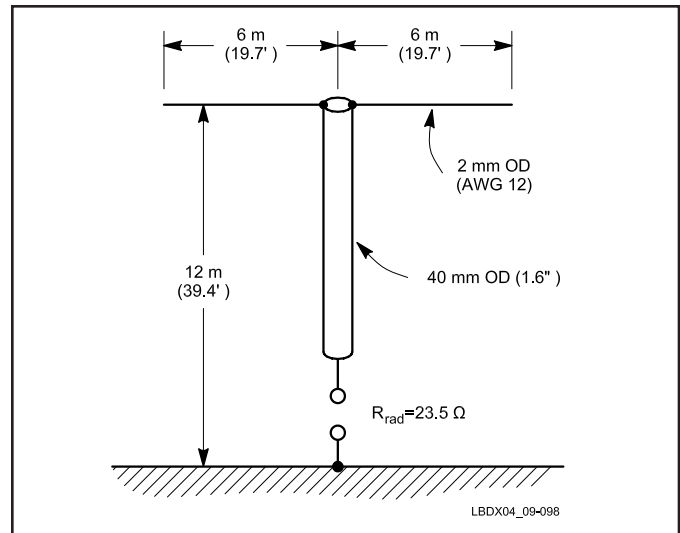

Fig 9-98—T-wire loaded current-fed $\lambda/4$ antenna for 3.5 MHz.

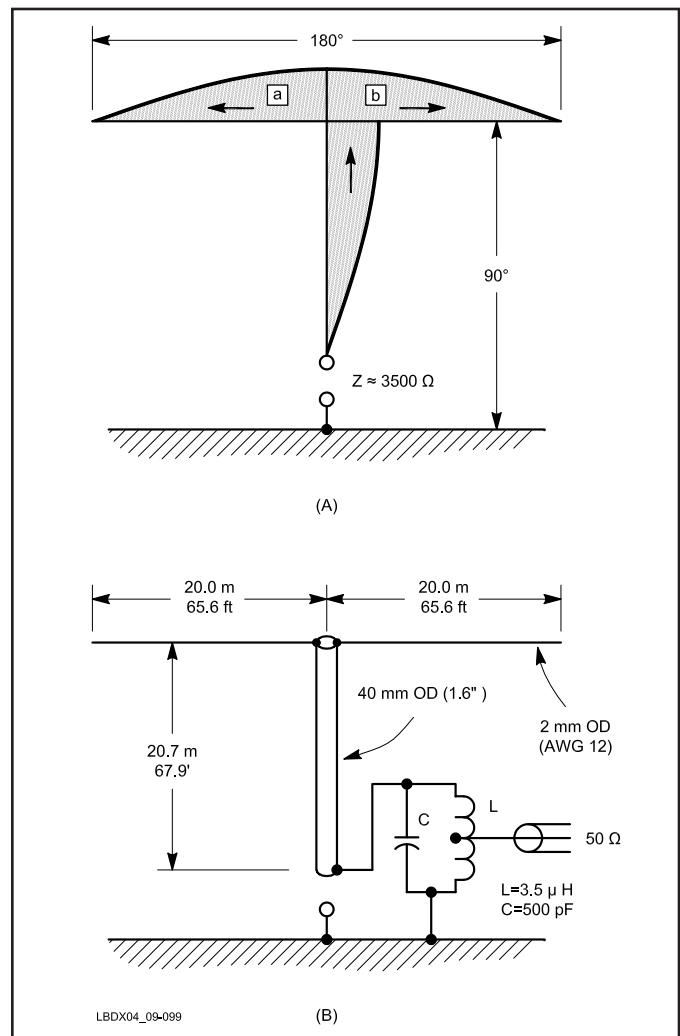

Fig 9-99—Voltage-fed 80-meter $\lambda/4$ vertical (also called inverted vertical), using a $\lambda/2$ long top-loading wire. The T wire has a twofold function—providing a low impedance at the top of the vertical, and having a configuration whereby horizontally polarized radiation is essentially canceled (area A = area B, hence no radiation). C—500 pF. L—3.5 μ H.

is at the antenna top. The antenna is sometimes called an inverted vertical, as it has its current maximum at the top. In theory, the current in both halves of the flat-top wire is such that radiation from that wire is zero. (In practice there is a very small amount of horizontal radiation.) The disadvantage of this construction is that the antenna requires a very long flat-top wire. Fig 9-99 also shows the dimensions for such a vertical for a practical design on 3.5 MHz.

Hille, DL1VU, dramatically improved the T antenna by folding the $\lambda/2$ flat-top section in such a way that the radiation from the flat-top section is effectively suppressed. **Fig 9-100** shows the configuration of this antenna. It can easily be proved that the area under the current distribution line for the central part (which is $\lambda/12$ long) is the same as the area for the remaining part of the loading device (which is $\lambda/6$ long). Because of the way the wires are folded, the radiation from the horizontal loading device is effectively canceled.

The latest design of a T-type top-load by Hille requires only a single $\lambda/4$ flat top. To cancel all possible horizontal radiation from this flat-top wire, the $\lambda/4$ is folded back as shown in **Fig 9-101**. Notice that the top load is asymmetrical.

A single quarter-wave flat top acts as a short circuit at the top of the vertical, the same way that radials provide a low-impedance attachment point for the outer conductor of the coax feed line in the case of a ground-plane antenna.

Hille also described a vertical with a physical length of only 0.39λ , using the $\lambda/4$ -long top-load wire configuration described above (Ref 7991). This antenna produces the same field strength as a $5\lambda/8$ (0.64λ) vertical antenna.

The T antenna can also be seen as a Bobtail Curtain antenna with the two vertical end sections missing. As such, this antenna is a poor performer with respect to the Bobtail antenna, where the directivity and gain is obtained through the use of three vertical elements.

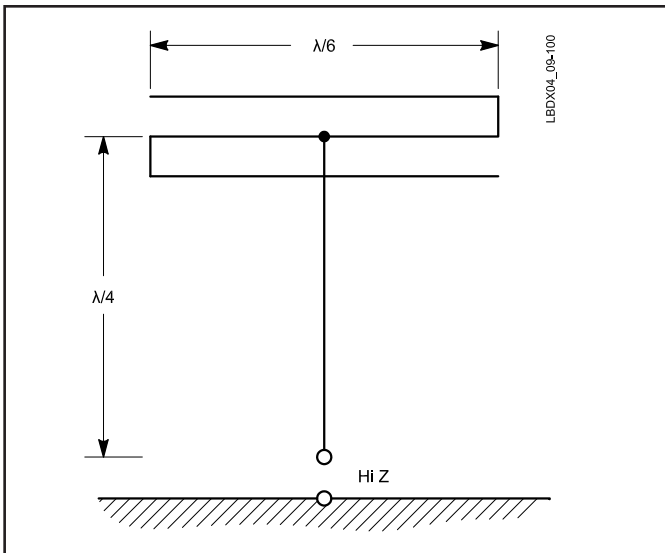

Fig 9-100—Voltage-fed $\lambda/4$ T antenna with the $\lambda/2$ flat-top wire folded to have a total span of only $\lambda/6$. The current distribution in the folded top load is such that radiation from the top load is effectively canceled. The advantage of this design over the original voltage-fed T antenna is that it requires a much shorter top-load space.

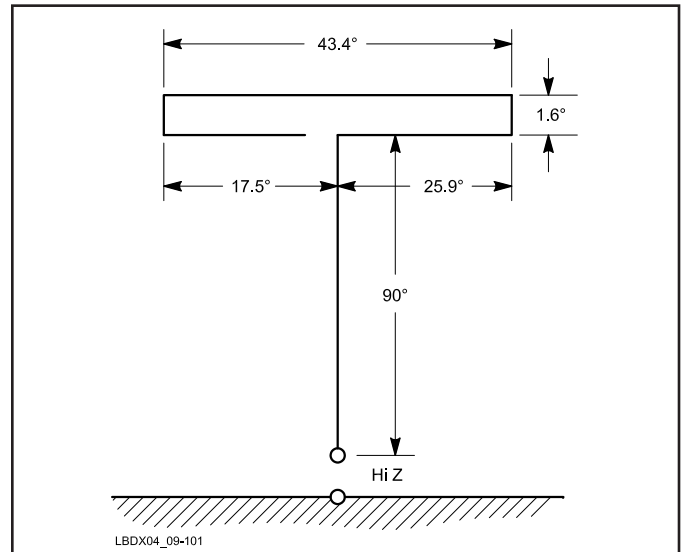

Fig 9-101—Voltage-fed T antenna with a $\lambda/4$ long top load, arranged in such a way that there is no radiation from the flat-top section.

8.2.1. Feeding the antenna

The voltage-fed T antenna can best be fed by means of a parallel tuned circuit (see Fig 9-99). You can either tap the coax on the coil for the lowest SWR point or tap the antenna near the top of the coil. Either method is valid.

8.2.2. The required ground and radial system

The ground and radial requirements are identical to those required for a $\lambda/2$ vertical (see Section 4.3).

8.3. Close Spaced Short Vertical and Reduced Losses

If you are in a situation where you cannot put down a good radial system (such as 100 $\lambda/4$ radials) for your short verticals, but you can erect several of those verticals close together (eg, with $\lambda/16$ spacing), this can be a way of improving the efficiency of your antenna.

John, W1FV, wrote: "I've been doing this for years on 160 with three 60-foot verticals (actually my 80-meter vertical system) spaced 35 feet apart. When fed in-phase, the feed-point radiation resistance at each vertical is around 18 ohms without a top hat. A single 60-foot vertical system has a radiation resistance of around one third of that. When the total system resistive loss (ground loss plus other component losses) is high (much bigger than 5-6 ohms), the efficiency of the three vertical system would be improved as much as a factor of three (5 dB) over a single vertical. For two in-phase verticals, the improvement would be around 3 dB. When the system loss starts out low and the single vertical efficiency is pretty good, there is obviously less to be gained, but that's also true when other loading schemes are used with short verticals."

This concept of using close-spaced in-phase verticals dates from 1920 (described in Jasik's *Antenna Engineering Handbook*, 1st Edition, page 19-9). Ground loss remains constant for a given area of ground system and antenna, because the sum of currents from each vertical flowing into that fixed

size ground system remains exactly the same no matter how many verticals are added.

The only improvement occurs when multiple antennas are far enough apart so that return currents at the base of one vertical are not influenced by currents from another vertical. This means that each antenna must have a small ground system area, well separated from the ground systems of the other verticals. The end result, however, is no better than making a single large ground system the exact size of the sum of the small ground systems.

To have an efficiency advantage in such a configuration there must be loss present in the verticals, including resistive ground loss (for example, a very small radial system). Resistive loss is proportional to current squared, so reducing current for constant power reduces loss. Since the drive currents to the verticals are split equally (in the ideal case) between N verticals, the current per vertical is $1/N$ times the current that would flow in one of the verticals by itself. This neglects the effects of mutual coupling, which are usually rather insignificant between short monopoles. This means the loss per vertical is $(1/N)^2$ times the loss of the single vertical. Since there are N verticals, the net system loss is N times $(1/N)^2$, or just $1/N$ times the loss of one vertical. This can be a significant improvement over a single vertical that would otherwise be lossy or inefficient by itself.

Tom, W8JI pointed out a possible application: *“Where this would help is when a driveway would be in the middle of an area, and you couldn’t cross the driveway with radials. You could build an antenna consisting of two verticals, with one on either side of the driveway, and separate “half” ground systems on either side that are not connected. In this example efficiency would be identical to a single vertical in the middle of the driveway with a full radial system that covers exactly the same physical area, but you can still have a driveway.”*

Another application of the principle would be where you would use four 80-meter verticals forming an 80-m Four Square, each vertical using a radial system designed for 80 meters, and where you would feed all four verticals in phase. That system acts like a single vertical of the same height placed in the exact middle of the 80-meter array. That would be better than feeding only one element at the edge of the ground system. But it gains nothing over a single vertical loaded the same way with the same area ground system, except convenience. W8JI pointed out: *“A Four Square works the same way. The center two elements combine to effectively make one element in the middle of the array. That is why we can feed a four-square with a 1:1:1:1 current ratio when a three-element array requires a 1:2:1 ratio! The center two elements (being in-phase) form one “radiation fat” element.”*

W8JI concluded saying: *“If it were a 160-only array, he almost certainly would be better off putting the same effort into a single vertical and one big ground system covering the same overall area. RCA found this to be true in an actual test at a VLF station, where they initially used multiple antenna elements over multiple distributed grounds to obtain the same $1/N$ efficiency as described above. When they pulled the multiple elements and the multiple independent ground systems out and replaced everything with a conventional system of radials filling the same area, efficiency actually went up a considerable amount (and they got rid of many maintenance*

headaches). Tom also points out that in recent tests (on VLF) the Air Force did at Marion the conclusion was a normal large radial ground system resulted in considerably less ground loss than had previously been obtained with a combination of multiple verticals using independent smaller ground systems, with a complex overhead distribution and equalizing system.”

9. LOCATION OF A VERTICAL ANTENNA

Let’s tackle the often-asked question, “Will a vertical work in my particular location?” Verticals for working DX on the low bands are certainly not space-saving antennas but to the contrary, require a lot of space and a good ground. Many low-band DXers have wondered why some verticals don’t work well at all, while others work “like gangbusters.” The poor performers generally have the poor locations. To repeat, a vertical is not a space-saving antenna! A good vertical takes a lot of real estate. In addition, it must be real estate with a good RF ground!

The standard for buried radials is that for best radiation efficiency you need $120 \lambda/2$ radials. This means that for 80 meters, you need about an 80×80-meter lot in which to place all the radials. The radials are there to provide a low-resistance return path for the antenna current to achieve good efficiency.

The area beyond the ends of the radials is at least as important, because that’s where the low-angle reflection at ground level takes place (the Fresnel zone). This is where the reflection efficiency is determined.

Up to $\lambda/2$ away from the vertical, most of the reflection will take place that is responsible for the 25° radiation (main angle) of a typical $\lambda/4$ vertical over average ground. Therefore, beyond this point, a clear path should be available for these low-angle rays to obtain maximum low-angle radiation. It is clear that for even lower angles of radiation, the ground at even greater distances becomes important. As explained earlier, this is even more so with “long” verticals (eg, $\lambda/2$ vertical), where the Fresnel reflection takes place up to 100λ away from the antenna (for wave angles down to 0.25°).

To avoid excessive absorption verticals should be kept at least $\lambda/4$ away from residential houses. This means, for instance, that at a point 60 meters from a 3.5-MHz antenna, the maximum height of a structure should be limited to 9.1 meters. What about trees closer in? Trees can be reasonably good conductors and can be very lossy elements in the near field of a radiator. A case has been reported in the literature where a $\lambda/4$ vertical with an excellent ground system showed a much lower radiation resistance than expected. It was found that trees in the immediate area were coupling heavily with the vertical and were causing the radiation resistance of the vertical to be very low. Under such circumstances of uncontrolled coupling into very lossy elements, far from optimum performance can be expected. Of course, if the trees are short in relation to the quarter wavelength, it is reasonable to assume that the result of such coupling will be minimal.

Even though neighboring (lossy) structures such as trees may not be resonant, they will always absorb some RF to an unknown degree. Other objects that are likely to affect the performance of a vertical are nearby antennas and towers. Mutual coupling can be considered the culprit if the radiation resistance of the vertical is lower than expected. Another way

of checking for coupling with other antennas is to alternately open and short-circuit the suspected antenna feed lines while watching the SWR or the radiation resistance of the vertical antenna. If there is any change, you are in trouble. Checking for resonance of towers has been described in Section 7.

It may come as a surprise that a vertical is so demanding of space. Most amateur verticals are not anywhere near ideal, yet good performance can still be obtained from practical setups. But the builder of a vertical should understand which factors are important for optimum performance, and why.

10. 160-METER DXPEDITION ANTENNAS

I have talked at great length with well-known DXpeditioners who have been especially successful on the low bands. I'd like to share the following rules with candidate DXpeditioners with respect to the low bands.

If you're on an island, erect the station on that side of the island where you will have the most difficult propagation path or where you are facing the most stations (eg, if you are on an island in the South Indian Ocean, try a shore on the northwest side of the island, looking into both Europe and North America). By all means erect the antenna very close to saltwater, or over (or in) saltwater. This will help you lower the pseudo-Brewster angle, and will ensure a good low-angle take off.

Unless you have a very tall support of at least 30 meters, use a vertical. Good choices are the Battle Creek Special, the BC Trapper, the AKI Special, the Titanex V160E or any inverted L, for which you should try to make the vertical part as long as possible. The vertical section should be at least 15-meters tall, 12 meters being an absolute minimum for 160 meters. If there are some trees, you may try to climb a tall tree, and use a collapsible fiberglass fishing rod (they exist in 12-meter lengths) to extend the effective support height. Use as many radials as you can, and let them run into the salt water. Very thin wire is just fine if you use many (current is shared by the many wires). A small spool of # 28 enameled copper magnet wire can hold a lot of wire and takes little space. Equally as good is to use two in-line elevated radials. These make switching from the CW to the phone band very simple by merely adjusting the length of the two radials.

The Titanex verticals are very special in that they are made of an aluminum-titanium alloy that is very strong and extremely lightweight. The model V160E vertical is a 26.7-meter long vertical that weighs only 7.5 kg. See **Fig 9-102**. The maximum section length is only 2.1 meters, and the total antenna can easily be erected by two to three persons. This, as well as the low weight, makes this a very attractive antenna for DXpeditions. The guy wires are 2-mm Kevlar, and guys are placed at heights of 6, 9, 12, 15 and 18 meters. The upper 8 meters of the vertical swings freely in the wind. With a total length of 26 meters, this antenna has a very respectable radiation resistance of 12Ω , which is 50% higher than that of the Battle Creek Special (which is 10 meters shorter!). The antenna is $3\lambda/8$ on 80, and $5\lambda/8$ on 40. Also on 40 this should make it a killer antenna if erected over saltwater. The V80E vertical measures only 20-meters tall, which is good for a R_{rad} of about 8.5Ω , which is similar to the R_{rad} of the Battle Creek Special. Titanex also provides a three-band relay-switched matchbox providing a 1:1 SWR on the three low bands. More info at www.qth.com/titanex. The Titanex antennas are expensive mechanical marvels but they have been used



Fig 9-102—The Titanex V160E antenna on the beach on VK9CR, surrounded by beautiful coconut trees. This 26.8-meter-long special DXpedition vertical weighs only 7.5 kg and disassembles into 2.1-meter long sections, ideal for traveling!

extremely successfully during a number of expeditions; eg, VK9CR, VK9XY, C56CW, FW2OI, S21XX, P29VXX, DL7FD/HR3, K7K, K4M, T31BB, 9M0C, TJ1GB, ZL7DK, YJ0ADJ, FO0FI, FO0FR, and 3B7RF.

Don't bother putting up a Beverage near the sea; it won't work well. The VK0IR guys did not believe me. They put one up; it never worked. Anyhow, it's unlikely you will have to deal with a lot of local QRM or man-made noise, which makes the use of directive antennas pretty senseless. If you do need directivity, try an EWE or a K9AY loop, which are receiving antennas that actually work better over good ground.

If there is a tall support, you may want to use a sloping half-wave vertical, especially if you are near the sea (see Chapter 8 on dipole antennas). The sloping vertical builds up its image as far as 100λ away from the antenna. If there is no saltwater nearby and ground conductivity is poor, use a high support for an inverted-V dipole. Don't try an inverted V or any other horizontally polarized antenna at a height of 15 meters or less. All you will get is very high-angle radiation.

Here is a hint from Rudi, DK7PE: If you are on a DXpedition in a country with a substantial tourist business, choose the tallest hotel (Hilton, Sheraton or Intercontinental hotels usually do well in this respect). Slope a dipole from the

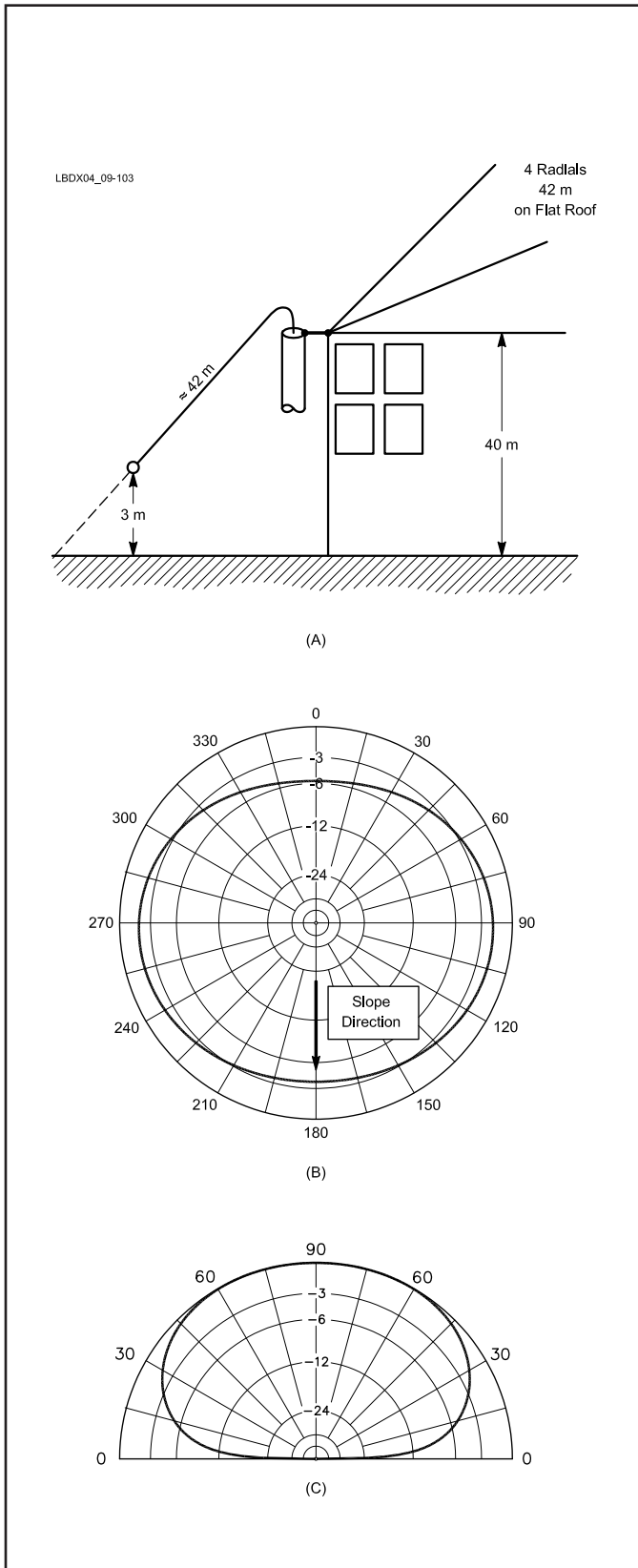

Fig 9-103—Configuration and radiation patterns of the inverted $\lambda/4$ sloper antenna used by 9M2AX. The azimuth pattern is shown at B for an elevation angle of 30°, and at C is the elevation pattern. (The elevation pattern is taken in the 90-270° direction as displayed in the azimuth pattern.) Note the relative high amount of high-angle radiation. Using just two radials in-line would improve this situation considerably.

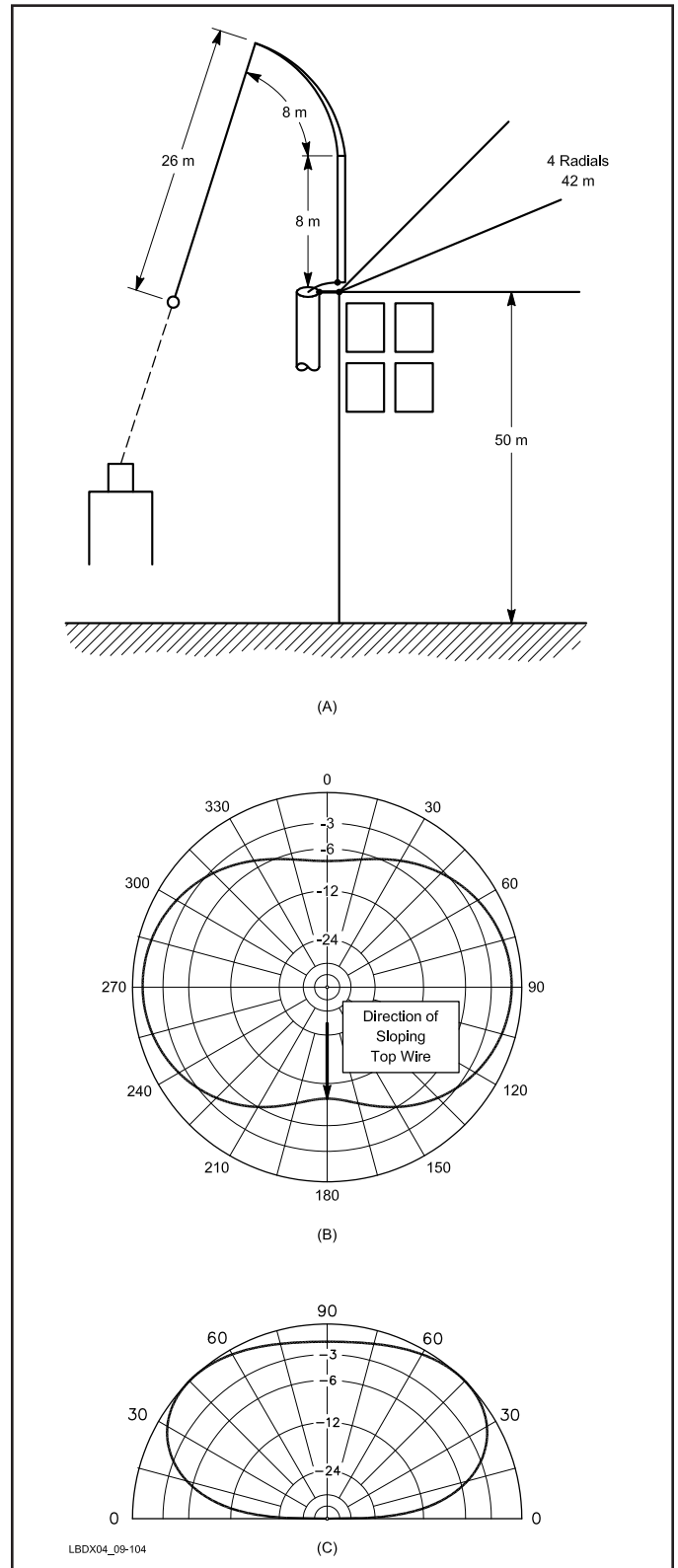

Fig 9-104—Configuration and radiation patterns of the inverted $\lambda/4$ sloper antenna used by 9M2AX during his expedition from East Malaysia (Sarawak) as 9M8AX. The azimuth pattern is shown at B, and the elevation pattern at C. (The elevation pattern is taken in the 90-270° direction as displayed in the azimuth pattern.) The antenna was installed on the edge of a 50-meter high flat roof. Four $\lambda/4$ long radials were laid on the roof. The metal mast plus the fiberglass rod are 16 meters long. The sloping wire was adjusted for minimum SWR at resonance.

top of the building to some distant point and let the feed line come to your room, which can be a few stories below the roof. Make the dipole as vertical as possible. This is by far the best antenna if you are in such a situation.

DK7PE proved it during his operation from D2CW (August 1992) where he had his sloping dipole attached some 60 meters above street level, facing north, and within 1λ of the South Atlantic Ocean. Rudi's signals were always S9 in Europe on 160 meters. During his more recent operation from Ethiopia and Eritrea (9F2CW), he proved it again. Rudi's total antenna system for his DXpeditions (covering 160 through 10 meters) can be packed in a small handbag. The RG-58 cable takes up 80% of the volume. The antenna consists of pre-cut lengths of flexible insulated wire, with small insulators and a variety of alligator clips that let him change bands. On the higher bands he can configure the wire into a 2-element Yagi.

R. E. Tanaka, 9M2AX, well-known 160-meter operator from the Far East, sent me the sketches of the antennas he is using in 9M2 as well as when he operated from 9M8AX. The antennas Ross was using can be put up at any tall hotel, and should be excellent suggestions for 160-meter DXpeditioners. **Figs 9-103 and 9-104** show the layouts of the two antenna setups and their radiation patterns. The radial system covering only one quadrant (90°) results in a significant high-angle radiation component with the 9M2AX version. The low-angle radiation is very pronounced as well. From modeling, the "inverted sloping wire vertical" from the 9M2 QTH has a feed-point impedance of about 75Ω . The 9M8AX configuration is an inverted L with a sloping flat-top. The calculated impedance from modeling is nearly 60Ω . This antenna has better low-angle radiation than the 9M2AX version, which is normal. In order to eliminate the high-angle radiation for the 9M2AX version, it would be necessary to install just two radials (in-line with one another), so that the radiation from these wires would be canceled. The radials are *not* there to provide a ground plane, but are merely serving to provide a low-impedance point to which to connect the outer shield of the feed line. One $\lambda/4$ radial would serve that purpose, but would radiate a lot of horizontal component. Two radials in-line would provide a low impedance point just as well, but would not radiate a high-angle horizontal component.

11. BUYING A COMMERCIAL VERTICAL

I sincerely hope that this chapter on verticals has incited you to build your own antenna. You cannot believe how much more satisfaction you get out of using something you made or designed yourself, rather than going to the store, opening your wallet and then playing the appliance-type ham.

Anyhow, if you choose not to make your own, here are a few rules to help you select your new low-band commercial vertical:

1. Most, if not all companies advertising their products, largely exaggerate the performance, especially if it's something different from a straightforward vertical.
2. A short vertical with a large bandwidth means there are a

lot of losses. With short antennas a large bandwidth is a direct measure of its poor efficiency (lots of losses).

3. The efficiency of a vertical is in the first place determined by the physical length of the vertical (and the ground system, which you will have to install yourself anyhow).
4. Only top loading is efficient.
5. Verticals with coil loading are bound to be inefficient. An 8-meter long vertical with center-coil loading is bound to be a very poor performer on 160 meters as a transmitting antenna.
6. To be a reasonable performer a minimum physical vertical length of about 14 meters is needed on 160 meters.
7. Good hardware (stainless steel, good finishing, etc) are no guarantee for a good antenna.
8. A fancy feed system or folded elements that claims to reduce losses and increase efficiency are a total fallacy.
9. A producer of a 160-meter vertical who prescribes using only a few 10-meter-long radials does not know what he is talking about.
10. Advertisers bragging that their product is bought by government agencies are not proving anything. Remember the Maxcom "dummy load" antenna-matching network used extensively by the armed forces?
11. An advertiser specifying his 8-meter long 160-meter vertical has 75% efficiency, without specifying the ground radial system is telling you stories.
12. Advertisers selling their product by telling how many new countries one of their customers has worked with it, are... Well, you know. Maybe, with a good homemade vertical he would have worked double the number of new countries! Not very scientific advertising, anyhow.

Spending nearly \$500 for a 9-meter long radiator is a heck of a lot of money. You could buy some simple aluminum tubing (TV-type push-up mast, about \$70), some copper wire to make a number of top-loading wires (add another \$10), some nylon guy rope (another \$10), maybe an (empty) Coke bottle for an insulator (free), and you have exactly the same for about 20% of the price of the commercial thing. It won't work any better, but at least you won't feel like you've been robbed. And spending nearly \$400 for an 8-meter-long 160-meter vertical, with a slim (and thus very lossy) loading coil, is even worse, of course.

Amateur Radio is a technical hobby. It is true that the progress of microelectronics has made it very difficult for the average ham to do much home designing and home building in the field of receivers and transmitters. Building antennas is one of the few fields where we can, ourselves, through our own knowledge, understanding and expertise, do as well and usually much better than the commercial companies. Let's grab this opportunity with both hands, and build our own vertical for the low bands. This will give you the ultimate kick, I promise you!