

OXFORD

CHANGE TABLE

MODEL # 092234
IMPORTANT: RETAIN FOR
FUTURE REFERENCE, READ
CAREFULLY



SAFETY PRECAUTIONS



Before assembling this change table, read and understand the instructions. Incorrect assembly may make the change table unsafe. Do not use this change table if any part is broken, torn or missing. Keep instructions in a safe place for future reference.

WARNING

DO NOT LEAVE THE CHILD UNATTENDED ON THE CHANGE TABLE.
TO PREVENT FALLS, DO NOT USE CHANGE PAD WITH A THICKNESS OF MORE THAN 30MM.
WHEN LOCKABLE CASTORS/WHEELS ARE FITTED, THEY SHOULD BE LOCKED WHEN THE CHANGE TABLE IS IN USE.

All assembly fittings should always be tightened properly and checked regularly.
To prevent falls, do not leave your baby unattended on the change table.
Both brakes on the castors must be applied before placing your baby on the change table.
Discontinue use once child reaches 12 months of age or 11kgs.
Do not allow older children to climb or play on the change table.
Do not use accessories other than those supplied and approved by CNP Brands.
Promptly replace worn out or broken parts.
Do not overtighten the bolts.
Be aware of the risk of open fires and other sources of strong heat, such as electric bar fires, gas fires etc. in close vicinity to the change table.
Do not use this change table if any part is broken, torn or missing.
Ensure children are clear of any moving parts when adjusting the change table.
For warranty purposes, keep your sales receipt to provide proof of purchase.

RECOMMENDED CHANGE PAD SIZE (NOT SUPPLIED):

This change table has been manufactured for use with a change pad which measures 750mm long x 500mm wide x 30mm in thickness.

We recommend the Childcare Universal Change Pad model #115140-003 to use with this change table. Place change pad on top of the change table ready for use.

Congratulations on your purchase of the bebe care Oxford Change Table.



This product has been designed and developed with safety, comfort and functionality in mind. Please take the time to read this manual carefully before using this product and keep it in a safe place for future reference.

Contents

Assembly contents list

Assembly instructions

How to care for your bebe care change table

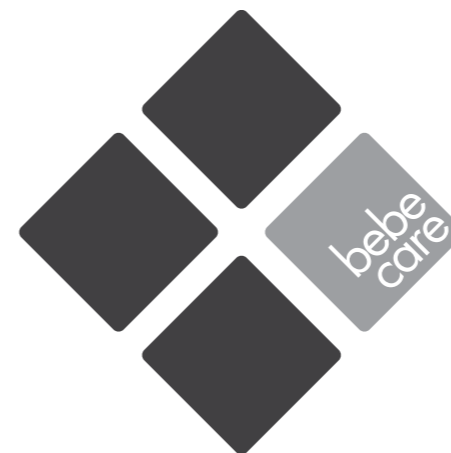

Due to variations in the style and design of our products, the photographs and illustrations shown in this instruction manual are generic, therefore product fabrics, colour and design may vary from images shown. CNP Brands reserves the right to alter product specifications without notice as a result of our ongoing policy of product improvement.

Assembly Contents

Check what you have received...

You have received 1 box. Please check the contents of the boxes against the list below. If anything is missing, please contact Customer Service. In Australia, contact CNP Brands on 1300 667 137, in New Zealand contact Wainhouse Distribution on 0800 567 5000.



Flat top rail (A)

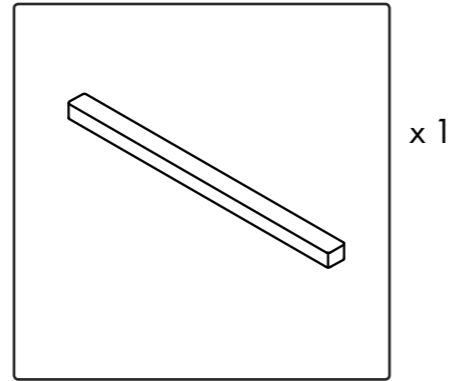

Arched top rail (B)

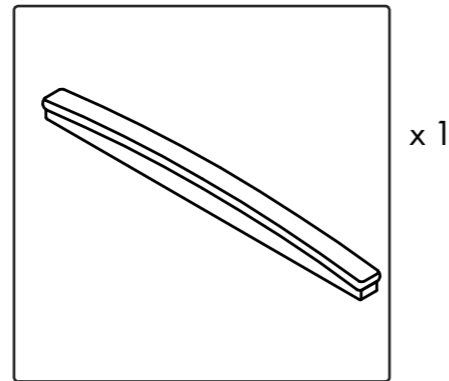

Headboard (C)

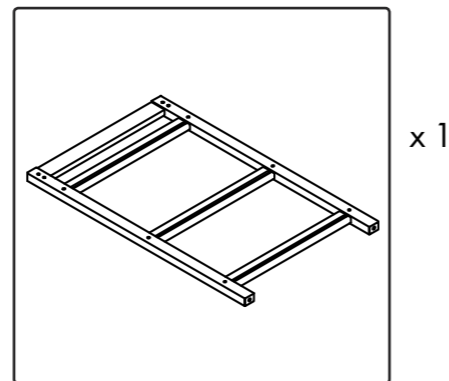

Foot end (D)

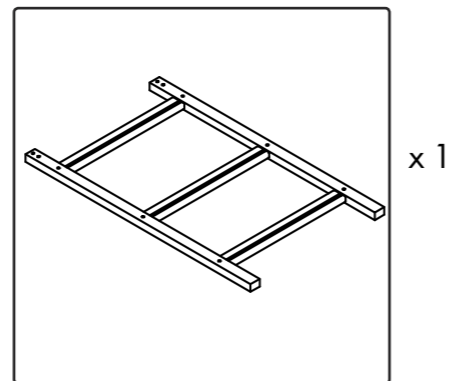

Hardware list (cont)



Shelves (E)

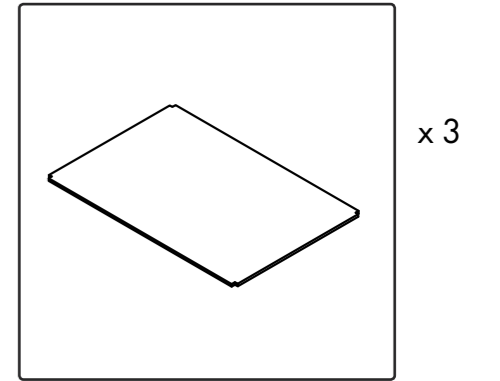

Top side rail (F)

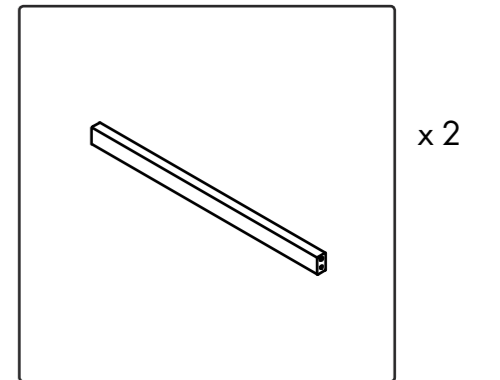

Rail (G)

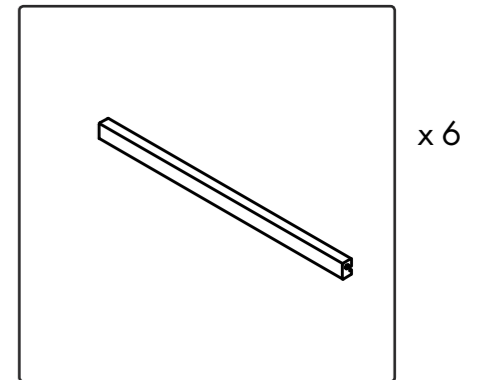

Castors (H)

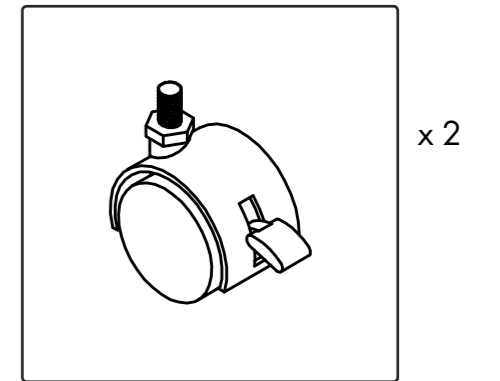

Hardware list (cont)



60mm Bolt (I)

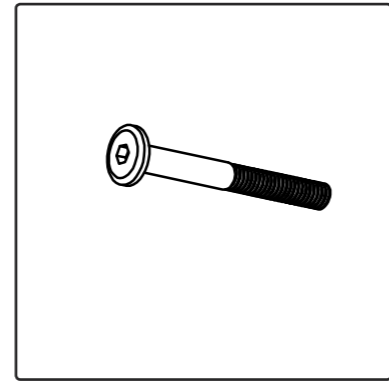

x 2

45mm Bolt (J)

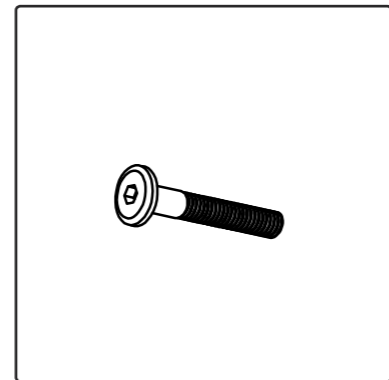

x 16

Allen key (K)

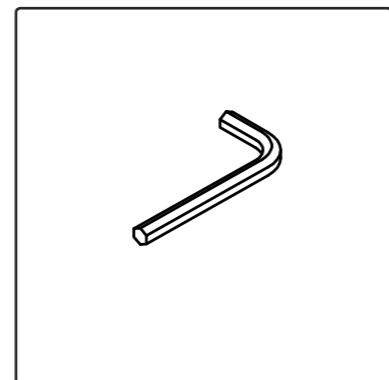

x 1

Open end wrench (L)

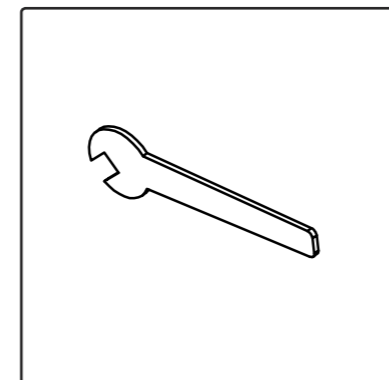

x 1

Assembly Instructions



As small parts are involved in assembly, children should be kept clear of the assembly area. Dispose of all packaging material immediately after the change table is assembled. Identify all parts and components. Clear an area on the floor for assembly and place a sheet on the floor to ensure the change table is not scratched during assembly.

Assembling top rail

1. Select either the Flat top rails (A) or the Arch top rails (B). Store other top rails.
2. Place selected top rail on top of the headboard (C).
3. Secure with 2 X 60mm bolts (I) by inserting them underneath the top end panel as shown. Tighten with supplied allen key (K)
4. Ensure bolts are secure.

⚠ **WARNING:** DO NOT over tighten bolts.

PLEASE NOTE: Previous steps under 'Attaching top rails' apply to both Flat top rail and Arch top rail.

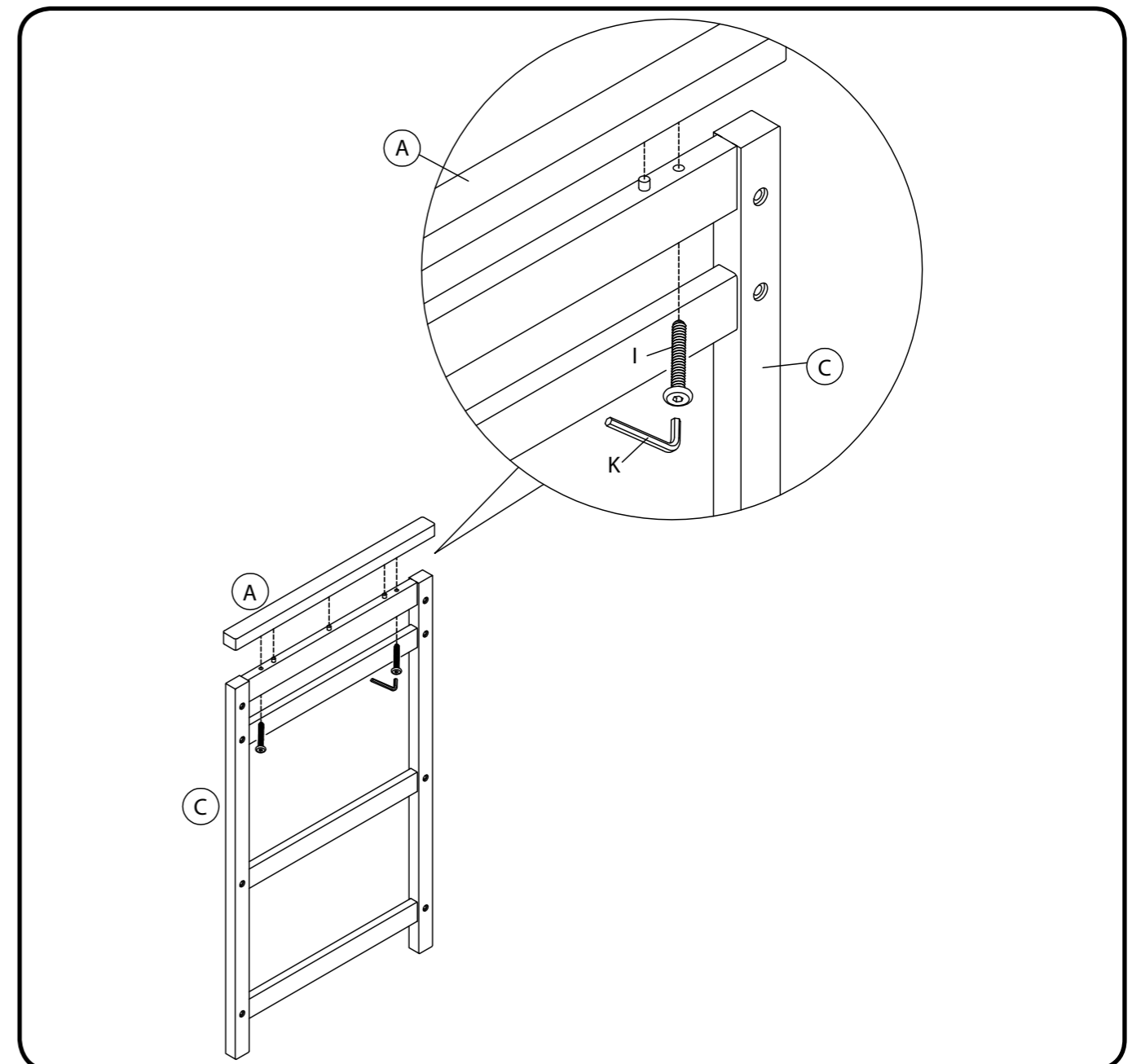

Assembly Instructions



Assembling side rails and footend

1. Assemble the 6 timber rails (G) with 6 x 45mm bolts (J) as per image shown on foot end (D) and tighten with allen key.
2. Assemble 2 x top side rails (F) with 2 x 45mm bolts (J) as per image shown on footend (D) and tighten with allen key.

PLEASE NOTE: Previous steps under 'Attaching top rails' apply to both Flat top rail and Arch top rail.

△ WARNING: Do not over-tighten bolts.

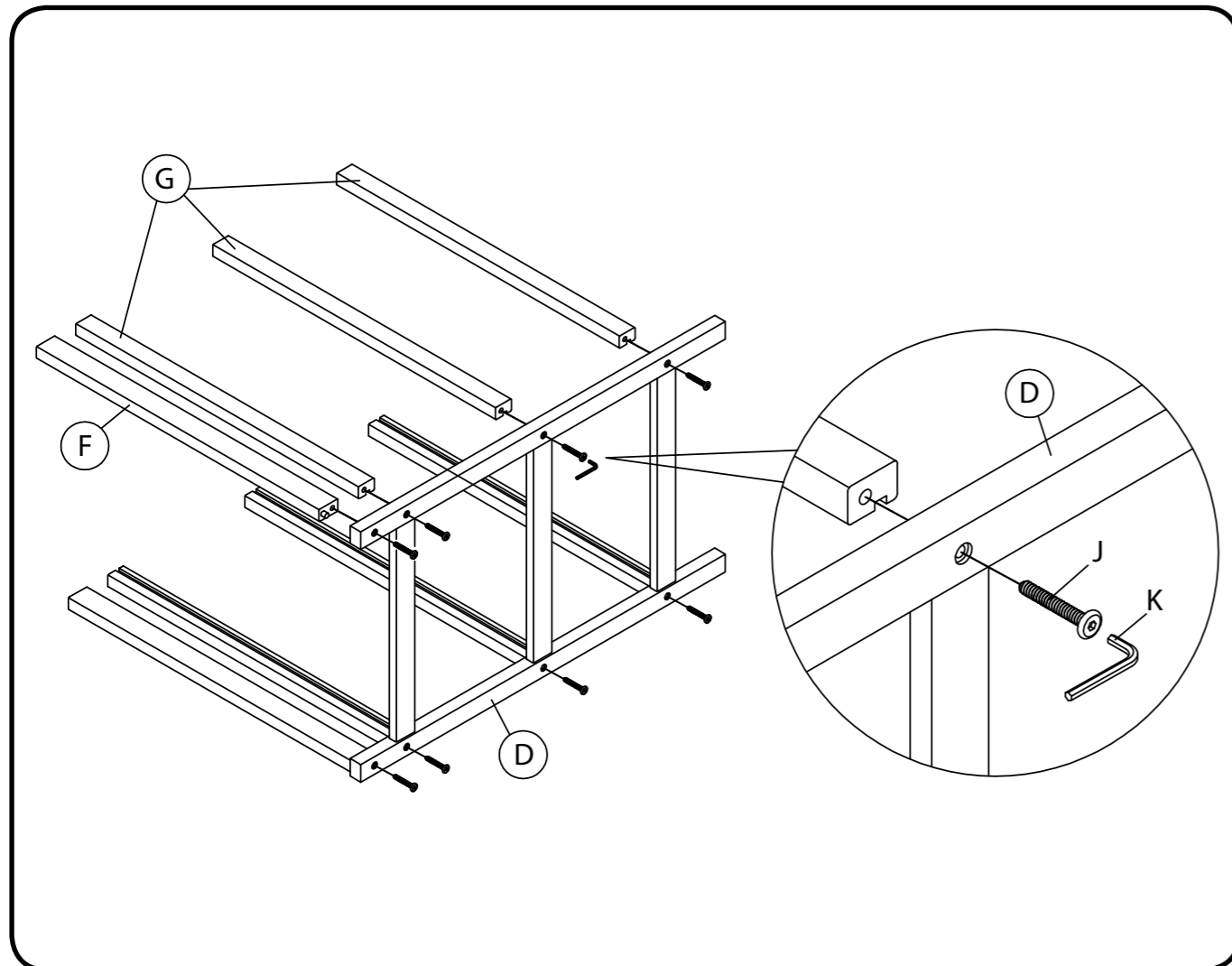

Assembly Instructions



Attaching shelves

1. Slide the 3 shelves (E) into the slots on the timber rails (D). Ensure they fit securely.

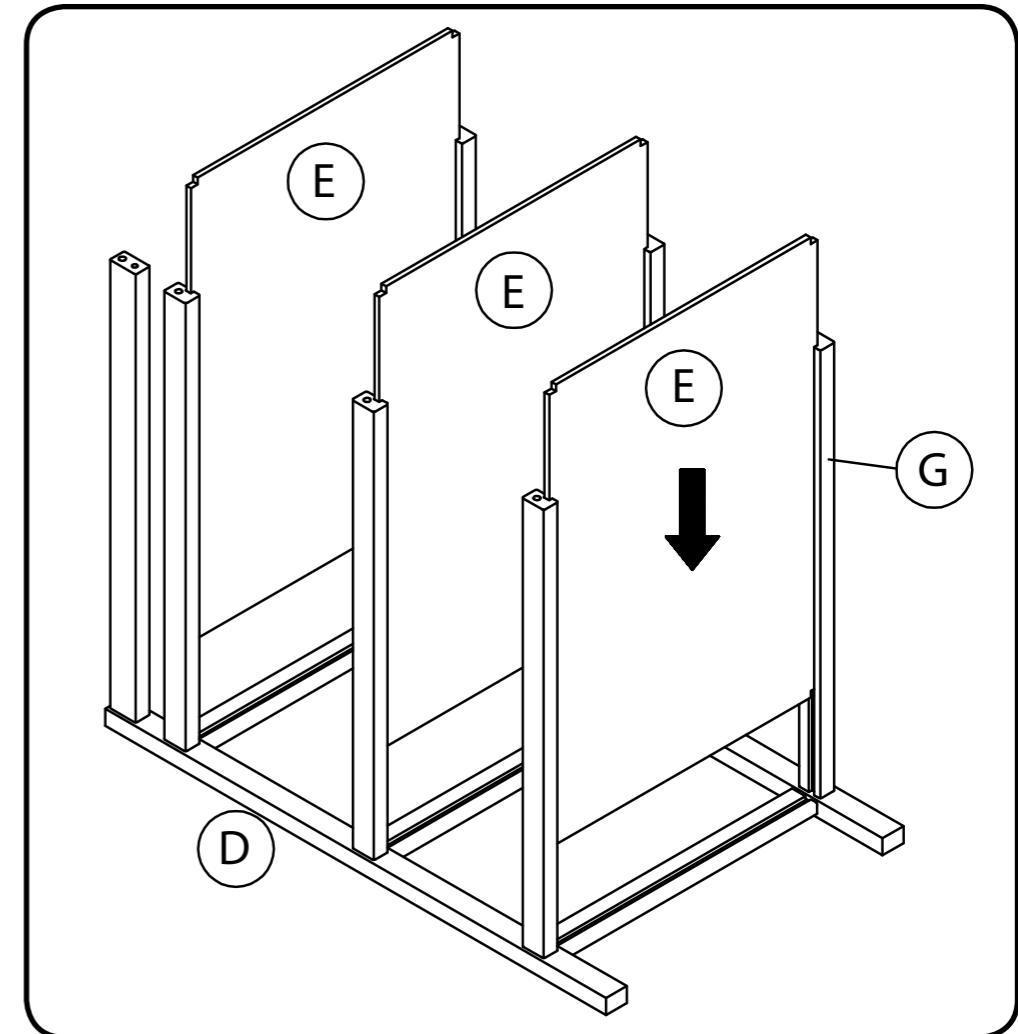

Assembly Instructions



Assembling headboard

1. Place headboard (C) on top of the rails (G) as per image.
2. Insert 8 x 45mm bolts (J) and tighten with allen key.

⚠ WARNING: Do not over-tighten bolts.

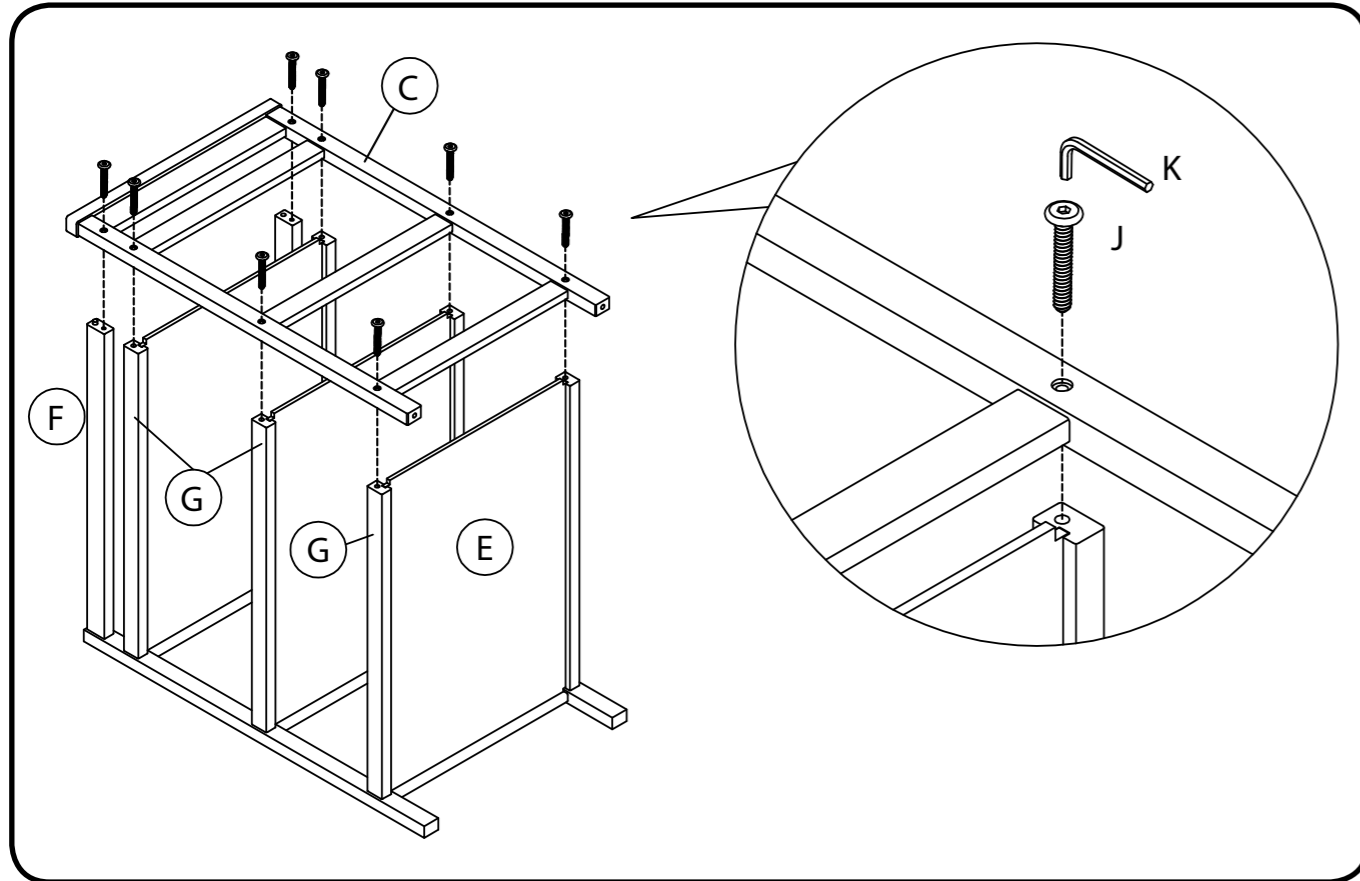

Assembly Instructions - Cot Mode



Assembling castors

1. Insert the castors (H) by turning them clockwise into the hole provided at the bottom of the headboard. Secure both castors with the wrench (L) supplied.

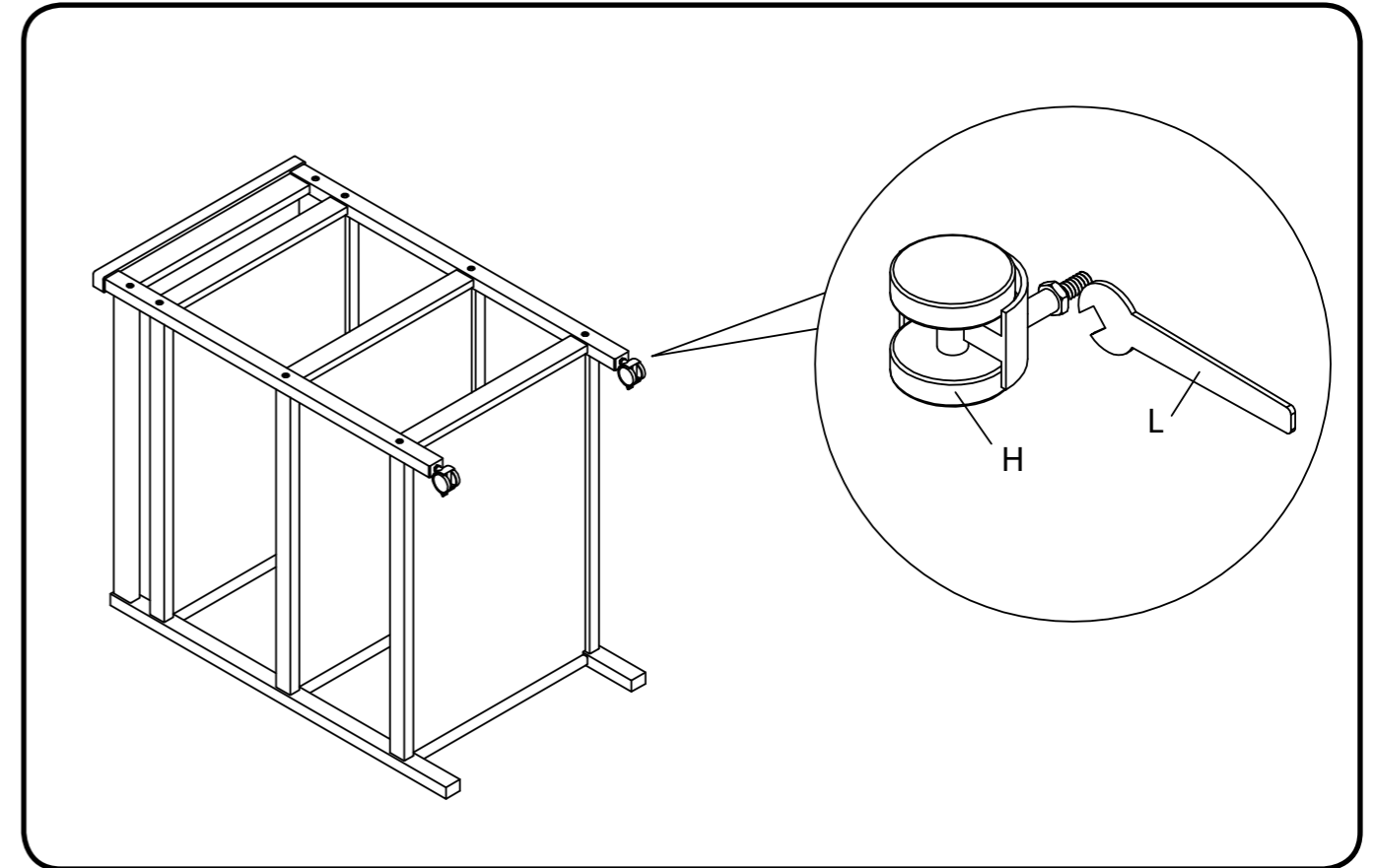

How to care for your Change Table



Cleaning

To ensure the long-lasting use of your change table, wipe down with a damp cloth and use a mild soap solution if necessary. Do not use abrasive cleaners. Always store product in a clean dry place.

Maintenance

Check rocker regularly to ensure that locking devices and components are secure and working properly. Always check parts regularly for tightness of screws, nuts and other fasteners – tighten or replace if required. To maintain the safety of your rocker, seek prompt repairs for bent, torn, worn or broken parts. Use only those parts and accessories approved by CNP Brands.

If you have any difficulties in assembling the rocker, please contact our Service Department. In Australia, contact CNP Brands on 1300 667 137, in New Zealand contact Wainhouse Distribution on 0800 567 5000.

Warranty Terms and Conditions



- 1.1 Our goods come with guarantees that cannot be excluded under the Australian Consumer Law. You are entitled to a replacement or refund for a major failure and compensation for any other reasonably foreseeable loss or damage. You are also entitled to have the goods repaired or replaced if goods fail to be of acceptable quality and the failure does not amount to a major failure.
- 1.2 In addition to the guarantees that cannot be excluded under the Australian Consumer Law described in clause 1.1 and any other guarantee or warranty implied by law, when you purchase one of our products, you will also have the peace of mind in knowing that your product is covered by CNP Brands Standard Warranty. The Standard Warranty is provided by C.O. White Pty Ltd trading as CNP Brands (ABN 97 004 169 233) ("CNP Brands"). The terms and conditions of the Standard Warranty are further described below.
- 1.3 Subject to clause 1.1 and the terms below, CNP Brands warrants that this CNP Brand product, purchased by you in Australia or New Zealand:
 - a) Is free from defects in workmanship and material, when the product is used for normal consumer use for a period of 2 years from the date of purchase as evidenced by your proof of purchase ("Warranty Term"); and
 - b) Will, when the product is used for normal consumer use, comply with the manufacturer's specifications during the Warranty Term.
- 1.4 CNP Brands agrees to repair or replace at CNP Brands cost, the product, and any accessory supplied with the product, which is proven upon inspection by CNP Brands or a CNP Brands Authorised Service Agent not to comply with either warranty contained in clause 1.3. Any decision to repair or replace a product is to be made by CNP in its absolute discretion. The extent of any repair will be to rectify any defect in workmanship and materials or to ensure that the product complies with the manufacturer's specifications.
- 1.5 To make a claim under this Standard Warranty you will need to:
 - a) Return the product within the Warranty Term to the place of purchase together with your proof of purchase, where the retailer will provide you with assistance to make your claim; or
 - b) Contact CNP Brands Customer Care Centre on toll free 1300 667 137 during the Warranty Term to register your claim and provide the details to enable CNP Brands to assess the claim.
- 1.6 You may also be required to make the product available to CNP Brands or a CNP Brands Authorised Service Agent. If you are required to return the product to a CNP Brands Authorised Service Agent, CNP Brands will provide details of the centre closest to you. Unless CNP Brands decides otherwise you are responsible for any costs associated with returning the product to CNP Brands. The product will be at your risk whilst in transit to and from the CNP Brands or CNP Brands Authorised Service Agent, unless transported by CNP Brands or its agents.
- 1.7 In order for your claim to be processed you will need to provide to CNP Brands with an original proof of purchase. For example an original retailer purchase receipt, bill of sale, invoice, lay-by docket, credit card receipt or similar proof of purchase.
- 1.8 If CNP Brands decide to repair a product, this product may be replaced by refurbished products of the same type rather than being repaired. Refurbished parts may be used to repair the product. Replacement of the product or a part does not extend or restart the Warranty Term.
- 1.9 Exclusions
 - a) This Standard Warranty does not cover products purchased as an ex-display, without being checked by CNP Brands or CNP Brands Authorised Service Agents.
 - b) This Standard Warranty does not cover faults or defects caused by:
 - i. Unsuitable, improper use or use not in accordance with the manufactures specifications;
 - ii. Incorrect installation or installation not in accordance with instructions provided;
 - iii. Normal wear and tear;
 - iv. Inadequate or complete lack of maintenance;
 - v. Chemical, electrochemical or electrical influences; or
 - vi. Harsh detergents or abrasive cleaners used on product finishes.
 - c) To the fullest extent permitted by law, CNP Brands excludes all liability for damage or injury to any person, damage to any property, and any indirect consequential or other loss or damage.

For Customer Service in Australia, contact CNP Brands on 1300 667 137 or email info@cnpbrands.com.au. In New Zealand contact Wainhouse Distribution on 0800 567 5000 or email helpline@wainhousedist.co.nz.



CNP BRANDS

CHILDCARE NURSERY PRODUCTS | EST. 1899



Distributed in Australia by CNP Brands, 20 Calarco Drive, VIC, 3030
Customer Service 1300 667 137

W: www.cnpbrands.com.au

E: info@cnpbrands.com.au

Distributed in New Zealand by Wainhouse Distribution, 2-6 Argyle St,
Morningside, PO Box 41-014, St Lukes, Auckland, New Zealand
Customer Service: 0800 567 5000

E: helpline@wainhousedist.co.nz

