

**Serial Number**

**5.4L  
100kW  
Models**

**STANDBY GENERATOR  
OWNER'S MANUAL**

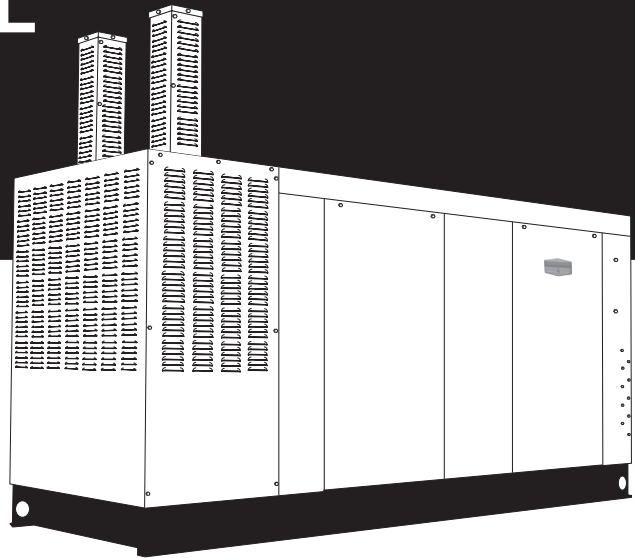

*A new standard of reliability*

**SIEMENS**

⚠ Not intended for use in critical life support applications. ⚠

— ⚠ **CAUTION** ⚠ —

**ONLY QUALIFIED ELECTRICIANS OR CONTRACTORS SHOULD ATTEMPT INSTALLATION!  
DEADLY EXHAUST FUMES. OUTDOOR INSTALLATION ONLY!**

This manual should remain with the unit.

<b>SECTION</b>	<b>PAGE</b>
<b>SAFETY RULES</b> .....	<b>1-1</b>
<b>INTRODUCTION</b> .....	<b>1-3</b>
Read this Manual Thoroughly .....	1-3
Operation and Maintenance .....	1-3
How to Obtain Service .....	1-3
<b>IDENTIFICATION RECORD</b> .....	<b>2-1</b>
Data Label .....	2-1
<b>EQUIPMENT DESCRIPTION</b> .....	<b>3-1</b>
Equipment Description .....	3-1
Engine Oil Recommendations .....	3-1
Coolant Recommendations .....	3-1
<b>ENGINE PROTECTIVE DEVICES</b> .....	<b>4-1</b>
Coolant Temperature Sensing .....	4-1
Low Coolant Level .....	4-1
Oil Pressure Sensing .....	4-1
Overcrank Shutdown .....	4-1
Overspeed Shutdown .....	4-1
RPM Sensor Loss Shutdown .....	4-1
DC Fuse .....	4-1
<b>FUEL SYSTEMS</b> .....	<b>5-1</b>
Fuel Requirements .....	5-1
Natural Gas Fuel System .....	5-1
Propane Vapor Withdrawal Fuel System .....	5-1
LP Fuel System .....	5-1
<b>SPECIFICATIONS</b> .....	<b>6-1</b>
Generator .....	6-1
Engine .....	6-1
Cooling System .....	6-1
Fuel System .....	6-1
Electrical System .....	6-1
Cold Weather Kit .....	6-2
5.4L & 6.8L Ignition Description .....	6-3
Ignition Power-up Input ("56 Line Input") .....	6-3
Ignition Enable ("14 Line Input") .....	6-3
Ignition Shutdown on Loss of Crank or CAM Signals .....	6-3
Diagnostic Blink Patterns (Red LED Located on the Ignition Control Board) .....	6-3
<b>GENERAL INFORMATION</b> .....	<b>7-1</b>
Generator AC Lead Connections .....	7-1
Four-lead, Single-phase Stator .....	7-1
Alternator Power Winding Connections .....	7-1
3-phase Alternators .....	7-1
<b>INSTALLATION</b> .....	<b>8-1</b>
Installation .....	8-1
Preparation Before Start-up .....	8-1
Transfer Switch .....	8-1
Fuel System .....	8-1
Generator Set Lubrication .....	8-1
Prior to Initial Start-up .....	8-1
Initial Inspection for QT Genset Start-up .....	8-2
Start-up Inspection .....	8-2
<b>OPERATION</b> .....	<b>9-1</b>
Generator Control and Operation .....	9-1
Operating Unit with Automatic Transfer Switch .....	9-1
Operating Unit with Manual Transfer Switch .....	9-1
Engine Start-up and Transfer .....	9-1
Retransfer and Shutdown .....	9-1
<b>MAINTENANCE</b> .....	<b>10-1</b>
Maintenance Performed by Authorized Service Facilities .....	10-1
Cooling System .....	10-1
Checking Fluid Levels .....	10-1
Check Engine Oil .....	10-1
Battery Fluid .....	10-1
Engine Coolant .....	10-2
Maintenance Owner/Operator Can Perform .....	10-2
Check Engine Oil Level .....	10-2
Check Battery .....	10-2
Exercise System .....	10-2
Inspect Cooling System .....	10-2
Check Engine Coolant Level .....	10-2
Perform Visual Inspection .....	10-2
Inspect Exhaust System .....	10-2
Check Fan Belt .....	10-2
Inspect Engine Governor .....	10-2
Changing Engine Oil .....	10-2
Changing the Engine Air Cleaner .....	10-3
Spark Plugs .....	10-3
Coolant Change .....	10-3
Miscellaneous Maintenance .....	10-3
Cleaning the Generator .....	10-3
Battery .....	10-4
Battery Maintenance .....	10-4
Battery Replacement .....	10-4
<b>SERVICE SCHEDULE</b> .....	<b>11-1</b>
30 kW - 150 kW Standby Gas Engine Driven Generator Sets .....	11-1
<b>TROUBLESHOOTING</b> .....	<b>12-1</b>
Troubleshooting Guide .....	12-1
<b>NOTES</b>	
<b>EXPLODED VIEWS &amp; PARTS LISTS</b>	
<b>WIRING DIAGRAMS &amp; SCHEMATICS</b>	
<b>WARRANTY</b>	



## Standby Generator Sets Important Safety Instructions



**⚠ SAVE THESE INSTRUCTIONS** – *The manufacturer suggests that these rules for safe operation be copied and posted in potential hazard areas. Safety should be stressed to all operators, potential operators, and service and repair technicians for this equipment.* **⚠**



### WARNING:



**The engine exhaust from this product contains chemicals known to the state of California to cause cancer, birth defects or other reproductive harm.**



### WARNING:



**This product contains or emits chemicals known to the state of California to cause cancer, birth defects or other reproductive harm.**

Study these SAFETY RULES carefully before installing, operating or servicing this equipment. Become familiar with this Owner's Manual and with the unit. The generator can operate safely, efficiently and reliably only if it is properly installed, operated and maintained. Many accidents are caused by failing to follow simple and fundamental rules or precautions.

The manufacturer cannot anticipate every possible circumstance that might involve a hazard. The warnings in this manual, and on tags and decals affixed to the unit are, therefore, not all inclusive. If a procedure, work method or operating technique is used that the manufacturer does not specifically recommend, ensure that it is safe for others. Also make sure the procedure, work method or operating technique utilized does not render the generator unsafe.

### ⚠ DANGER ⚠

- ⚠** Despite the safe design of this generator, operating this equipment imprudently, neglecting its maintenance or being careless can cause possible injury or death. Permit only responsible and capable persons to install, operate or maintain this equipment.
- ⚠** Potentially lethal voltages are generated by these machines. Ensure all steps are taken to render the machine safe before attempting to work on the generator.
- ⚠** Parts of the generator are rotating and/or hot during operation. Exercise care near running generators.

### ⚠ GENERAL HAZARDS ⚠

- For safety reasons, the manufacturer recommends that this equipment be installed, serviced and repaired by an Authorized Service Dealer or other competent, qualified electrician or installation technician who is familiar with applicable codes, standards and regulations. The operator also must comply with all such codes, standards and regulations.
- Installation, operation, servicing and repair of this (and related) equipment must always comply with applicable codes, standards, laws and regulations. Adhere strictly to local, state and national electrical and building codes. Comply with regulations the Occupational Safety and Health Administration (OSHA) has established. Also, ensure that the generator is installed, operated and serviced in accordance with the manufacturer's instructions and recommendations. Following installation, do nothing that might render the unit unsafe or in noncompliance with the aforementioned codes, standards, laws and regulations.
- The engine exhaust fumes contain carbon monoxide gas, which can be DEADLY. This dangerous gas, if breathed in sufficient concentrations, can cause unconsciousness or even death. For that reason, adequate ventilation must be provided. Exhaust gases must be piped safely away from any building or enclosure that houses the generator to an area where people, animals, etc., will not be harmed. This exhaust system must be installed properly, in strict compliance with applicable codes and standards.
- Keep hands, feet, clothing, etc., away from drive belts, fans, and other moving or hot parts. Never remove any drive belt or fan guard while the unit is operating.
- Adequate, unobstructed flow of cooling and ventilating air is critical in any room or building housing the generator to prevent buildup of explosive gases and to ensure correct generator operation. Do not alter the installation or permit even partial blockage of ventilation provisions, as this can seriously affect safe operation of the generator.
- Keep the area around the generator clean and uncluttered. Remove any materials that could become hazardous.
- When working on this equipment, remain alert at all times. Never work on the equipment when physically or mentally fatigued.
- Inspect the generator regularly, and promptly repair or replace all worn, damaged or defective parts using only factory-approved parts.



## Standby Generator Sets Important Safety Instructions



- Before performing any maintenance on the generator, disconnect its battery cables to prevent accidental start-up. Disconnect the cable from the battery post indicated by a NEGATIVE, NEG or (-) first. Reconnect that cable last.
- Never use the generator or any of its parts as a step. Stepping on the unit can stress and break parts, and may result in dangerous operating conditions from leaking exhaust gases, fuel leakage, oil leakage, etc.

### **ELECTRICAL HAZARDS**

- All generators covered by this manual produce dangerous electrical voltages and can cause fatal electrical shock. Utility power delivers extremely high and dangerous voltages to the transfer switch as well as the standby generator. Avoid contact with bare wires, terminals, connections, etc., on the generator as well as the transfer switch, if applicable. Ensure all appropriate covers, guards and barriers are in place before operating the generator. If work must be done around an operating unit, stand on an insulated, dry surface to reduce shock hazard.
- Do not handle any kind of electrical device while standing in water, while barefoot, or while hands or feet are wet. DANGEROUS ELECTRICAL SHOCK MAY RESULT.
- If personnel must stand on metal or concrete while installing, operating, servicing, adjusting or repairing this equipment, place insulative mats over a dry wooden platform. Work on the equipment only while standing on such insulative mats.
- The National Electrical Code (NEC) requires the frame and external electrically conductive parts of the generator to be connected to an approved earth ground. This grounding will help prevent dangerous electrical shock that might be caused by a ground fault condition in the generator set or by static electricity. Never disconnect the ground wire.
- Wire gauge sizes of electrical wiring, cables and cord sets must be adequate to handle the maximum electrical current (ampacity) to which they will be subjected.
- Before installing or servicing this (and related) equipment, make sure that all power voltage supplies are positively turned off at their source. Failure to do so will result in hazardous and possibly fatal electrical shock.
- Connecting this unit to an electrical system normally supplied by an electric utility shall be by means of a transfer switch so as to isolate the generator electric system from the electric utility distribution system when the generator is operating. Failure to isolate the two electric system power sources from each other by such means will result in damage to the generator and may also result in injury or death to utility power workers due to backfeed of electrical energy.

- Generators installed with an automatic transfer switch will crank and start automatically when normal (utility) source voltage is removed or is below an acceptable preset level. To prevent such automatic start-up and possible injury to personnel, disable the generator's automatic start circuit (battery cables, etc.) before working on or around the unit. Then, place a "Do Not Operate" tag on the generator control panel and on the transfer switch.
- In case of accident caused by electric shock, immediately shut down the source of electrical power. If this is not possible, attempt to free the victim from the live conductor. AVOID DIRECT CONTACT WITH THE VICTIM. Use a nonconducting implement, such as a dry rope or board, to free the victim from the live conductor. If the victim is unconscious, apply first aid and get immediate medical help.
- Never wear jewelry when working on this equipment. Jewelry can conduct electricity resulting in electric shock, or may get caught in moving components causing injury.

### **FIRE HAZARDS**

- Keep a fire extinguisher near the generator at all times. Do NOT use any carbon tetra-chloride type extinguisher. Its fumes are toxic, and the liquid can deteriorate wiring insulation. Keep the extinguisher properly charged and be familiar with its use. If there are any questions pertaining to fire extinguishers, consult the local fire department.

### **EXPLOSION HAZARDS**

- Properly ventilate any room or building housing the generator to prevent build-up of explosive gas.
- Do not smoke around the generator. Wipe up any fuel or oil spills immediately. Ensure that no combustible materials are left in the generator compartment, or on or near the generator, as FIRE or EXPLOSION may result. Keep the area surrounding the generator clean and free from debris.
- These generator sets may operate using one of several types of fuels. All fuel types are potentially FLAMMABLE and/or EXPLOSIVE and should be handled with care. Comply with all laws regulating the storage and handling of fuels. Inspect the unit's fuel system frequently and correct any leaks immediately. Fuel supply lines must be properly installed, purged and leak tested according to applicable fuel-gas codes before placing this equipment into service.
- Diesel fuels are highly FLAMMABLE. Gaseous fluids such as natural gas and liquid propane (LP) gas are extremely EXPLOSIVE. Natural gas is lighter than air, and LP gas is heavier than air; install leak detectors accordingly.



## INTRODUCTION

Thank you for purchasing this model of the standby generator set product line.

Every effort was expended to make sure that the information and instructions in this manual were both accurate and current at the time the manual was written. However, the manufacturer reserves the right to change, alter or otherwise improve this product(s) at any time without prior notice.

### ◆ READ THIS MANUAL THOROUGHLY

If any portion of this manual is not understood, contact the nearest Authorized Service Dealer for starting, operating and servicing procedures.

Throughout this publication, and on tags and decals affixed to the generator, DANGER, WARNING, CAUTION and NOTE blocks are used to alert personnel to special instructions about a particular service or operation that may be hazardous if performed incorrectly or carelessly. Observe them carefully. Their definitions are as follows:



**After this heading, read instructions that, if not strictly complied with, will result in personal injury or property damage.**



**After this heading, read instructions that, if not strictly complied with, may result in personal injury or property damage.**



**After this heading, read instructions that, if not strictly complied with, could result in damage to equipment and/or property.**

#### NOTE:

**After this heading, read explanatory statements that require special emphasis.**

These safety warnings cannot eliminate the hazards that they indicate. Common sense and strict compliance with the special instructions while performing the service are essential to preventing accidents.

Four commonly used safety symbols accompany the DANGER, WARNING and CAUTION blocks. The type of information each indicates is as follows:

 This symbol points out important safety information that, if not followed, could endanger personal safety and/or property of others.

 This symbol points out potential explosion hazard.

 This symbol points out potential fire hazard.

 This symbol points out potential electrical shock hazard.

The operator is responsible for proper and safe use of the equipment. The manufacturer strongly recommends that the operator read this Owner's Manual and thoroughly understand all instructions before using this equipment. The manufacturer also strongly recommends instructing other users to properly start and operate the unit. This prepares them if they need to operate the equipment in an emergency.

### ◆ OPERATION AND MAINTENANCE

It is the operator's responsibility to perform all safety checks, to make sure that all maintenance for safe operation is performed promptly, and to have the equipment checked periodically by an Authorized Service Dealer. Normal maintenance service and replacement of parts are the responsibility of the owner/operator and, as such, are not considered defects in materials or workmanship within the terms of the warranty. Individual operating habits and usage contribute to the need for maintenance service.

Proper maintenance and care of the generator ensure a minimum number of problems and keep operating expenses at a minimum. See an Authorized Service Dealer for service aids and accessories.

Operating instructions presented in this manual assume that the standby electric system has been installed by an Authorized Service Dealer or other competent, qualified contractor. Installation of this equipment is not a "do-it-yourself" project.

### ◆ HOW TO OBTAIN SERVICE

When the generator requires servicing or repairs, simply contact an Authorized Service Dealer for assistance. Service technicians are factory-trained and are capable of handling all service needs.

When contacting an Authorized Service Dealer or the factory about parts and service, always supply the complete model number of the unit as given on the front cover of this manual or on the DATA LABEL affixed to the unit.

#### AUTHORIZED SERVICE DEALER LOCATION

To locate the nearest AUTHORIZED SERVICE DEALER, please call this number:

**1-800-333-1322**

or locate us on the web at:

**www.generac.com**

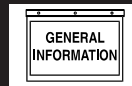
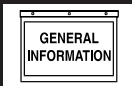

## IDENTIFICATION RECORD

### ◆ DATA LABEL

Every generator set has a DATA LABEL that contains important information pertinent to the generator. The data label, which can be found attached to the generator's lower connection box, lists the unit's serial number and its rated voltage, amps, wattage capacity, phase, frequency, rpm, power factor, etc.

### NOTE:

**For actual information related to this particular model, please refer to the Manual Drawing Listing located at the end of this manual, or to the data label affixed to the unit.**

#### ✦ Generator Model and Serial Number

This number is the key to numerous engineering and manufacturing details pertaining to your unit. Always supply this number when requesting service, ordering parts or seeking information.

### *Data Label*

**GENERATOR SET DATA** MADE IN USA

MODEL  SERIAL

RATED KW  RATED KVA  PHASE

RATED VOLTAGE  RATED AMPS

POWER FACTOR  HERTZ  ALT RPM

ENGINE RPM  PRODUCTION DATE

ALTERNATOR SUBTRANSIENT REACTANCE

ALTERNATOR TRANSIENT REACTANCE

CLASS  ROTOR  STATOR WINDING INSULATION AT 25°C AMBIENT

**GENERAC POWER SYSTEMS, INC.**

## EQUIPMENT DESCRIPTION

This equipment is a revolving field, alternating current generator set. It is powered by a gaseous fueled engine operating at 1800 rpm for 4-pole direct drive units, 3600 rpm for 2-pole direct drive units and 2300 - 3000 rpm for quiet drive gear units. See the Specifications section for exact numbers. The unit comes complete with a sound attenuated enclosure, internally mounted muffler, control console, main-line circuit breaker, battery charger, and protective alarms as explained in the following paragraph.

All AC connections, including the power leads from the alternator, 120 volt battery charger input and control connections to the transfer switch are available in the main connection box.

The generator incorporates the following generator features:

- Rotor and Stator insulation is Class H rated as defined by NEMA MG1-32.6, NEMA MG1-1.66. The generator is self ventilated and drip-proof constructed.
- The voltage waveform deviation, total harmonic content of the AC waveform and telephone influence factor have been evaluated and are acceptable according to NEMA MG1-32.

## ENGINE OIL RECOMMENDATIONS

The unit has been filled with 15W-40 engine oil at the factory. Use a high-quality detergent oil classified "For Service SJ or SH." Detergent oils keep the engine cleaner and reduce carbon deposits. Use oil having the following SAE viscosity rating, based on the ambient temperature range anticipated before the next oil change:

Temperature	Oil Grade (Recommended)
Above 80° F (27° C)	SAE 30W or 15W-40
32° to 80° F (0° to 27° C)	SAE 20W-20 or 15W-40
Below 32° F (0° C)	See Note

—  CAUTION  —

 Any attempt to crank or start the engine before it has been properly serviced with the recommended oil may result in an engine failure.

**NOTE:**

**For temperatures below 32° F, it is strongly recommended to use the optional Cold Weather Start Kit (part number listed in the Specification Section). The oil grade for temperatures below 32° F is 5W-30 synthetic oil.**

## COOLANT RECOMMENDATIONS

Use a mixture of half low silicate ethylene glycol base anti-freeze and deionized water. Cooling system capacity is listed in the specifications. Use only deionized water and only low silicate anti-freeze. If desired, add a high quality rust inhibitor to the recommended coolant mixture. When adding coolant, always add the recommended 50-50 mixture.

—  CAUTION  —

 Do not use any chromate base rust inhibitor with ethylene glycol base anti-freeze or chromium hydroxide ("green slime") forms and will cause overheating. Engines that have been operated with a chromate base rust inhibitor must be chemically cleaned before adding ethylene glycol base anti-freeze. Using any high silicate anti-freeze boosters or additives will also cause overheating. The manufacturer also recommends that any soluble oil inhibitor is NOT used for this equipment.

—  DANGER  —

 Do not remove the radiator pressure cap while the engine is hot or serious burns from boiling liquid or steam could result.

 Ethylene glycol base antifreeze is poisonous. Do not use mouth to siphon coolant from the radiator, recovery bottle or any container. Wash hands thoroughly after handling. Never store used antifreeze in an open container because animals are attracted to the smell and taste of antifreeze even though it is poisonous to them.

## ENGINE PROTECTIVE DEVICES

The standby generator may be required to operate for long periods of time without an operator on hand to monitor such engine conditions as coolant temperature, oil pressure or rpm. For that reason, the engine has several devices designed to protect it against potentially damaging conditions by automatically shutting down the unit when the oil pressure is too low, the coolant temperature is too high, the coolant level is too low, or the engine is running too fast.

### NOTE:

**Engine protective switches and sensors are mentioned here for the reader's convenience. Also refer to the applicable control panel manual for additional automatic engine shutdown information.**

### ◆ COOLANT TEMPERATURE SENSING

An analog Water Temperature Sender (WTS) is located in the engine's cooling system. This sender is connected to the panel and allows the panel to monitor and display the temperature of the coolant system.

The WTS is a resistive device whose resistance changes based on coolant temperature. The resistance of the sender results in a voltage being developed across the sender. As the Coolant temperature increases, the resistance will decrease, causing the voltage to decrease. This changing voltage is converted to 4-20mA signal by a signal conditioner module. The corresponding 4-20mA signal is read by the control panel and displayed as the coolant temperature.

The control panel will monitor and display the coolant temperature anytime the DC input to the control panel is present.

If the temperature exceeds approximately 140° C (284° F), the engine shutdown will be initiated. The generator will automatically restart and the display will reset once the temperature has returned to an operating level.

### ◆ LOW COOLANT LEVEL

A Low Coolant Level (LCL) sensor is placed in the generators coolant system. This sensor allows the panel to detect a Low Coolant Level condition.

The LCL is a resistive device whose resistance changes rapidly based on the presence or absence of coolant.

The resistance of the LCL results in a voltage being developed across the LCL. This voltage changes as the resistance changes. This changing voltage is converted to 4-20mA signal by a signal conditioner module. The corresponding 4-20mA signal is read by the control panel and displayed as the low coolant level.

If the level of the engine coolant drops below the level of the low coolant level sensor, the engine shutdown will be initiated.

### ◆ OIL PRESSURE SENSING

An analog Oil Pressure Sender (OPS) is used for monitoring the engine oil pressure. This sender allows the control panel to measure and display the Engine oil pressure.

The OPS is a resistive device, whose resistance changes based on engine oil pressure. The resistance of the sender results in a voltage being developed across the sender. As the oil pressure increases, the resistance will decrease, causing the voltage to decrease. This changing voltage is converted to 4-20mA signal by a signal conditioner module. The corresponding 4-20mA signal is read by the control panel and displayed as the oil pressure.

The control panel will monitor and display oil pressure anytime the DC input to the control panel is present.

Should the oil pressure drop below the 8 psi range, the engine shutdown is initiated. The unit should not be restarted until oil is added. Turn the AUTO/OFF/MANUAL switch to the OFF position, then back to AUTO to restart.

### ◆ OVERCRANK SHUTDOWN

When the control panel receives a start signal, it initiates the programmed starting sequence. The start sequence consists of the number of crank attempts, the length of each crank attempt, and the rest time between each crank attempt. If the engine has not started by the end of the final crank attempt, an Overcrank alarm is generated, the control panel will sound the alarm and display the message "Failed to start".

### ◆ OVERSPEED SHUTDOWN

A speed circuit controls engine cranking, start-up, operation and shutdown. Engine speed signals are delivered to the circuit board whenever the unit is running. Should the engine over speed above a safe, preset value, the circuit board initiates an automatic engine shutdown. Contact the nearest Authorized Dealer if this failure occurs.

### ◆ RPM SENSOR LOSS SHUTDOWN

If the speed signal to the control panel is lost, engine shutdown will occur.

### ◆ DC FUSE

This fuse is located inside of the control panel. It protects the panel wiring and components from damaging overload. Always remove this fuse before commencing work on the generator. The unit will not start or crank if the fuse is blown. Replace the fuse with one of the same size, type, and rating. (See the exploded views and parts lists at the end of this manual for replacement part number.)



## FUEL SYSTEM

### ◆ FUEL REQUIREMENTS

The standby generator may be equipped with one of the following fuel systems:

- Natural gas fuel system
- Propane vapor (PV) fuel system
- Liquid propane (LP) fuel system

The Manual Drawing Listing that is affixed to the unit includes the "Identification Code," which may be used to identify the type of fuel system installed on the unit.

Recommended fuels should have a Btu content of at least 1,000 Btu's per cubic foot for natural gas; or at least 2,520 Btu's per cubic foot for LP gas. Ask the fuel supplier for the Btu content of the fuel.

Required fuel pressure for **natural gas is 11 inches to 14 inches water column (0.4 to 0.5 psi); and for liquid propane, 11 inches to 14 inches of water column (0.4 to 0.5 psi).**

#### NOTE:

**Any piping used to connect the generator to the fuel supply should be of adequate size to ensure the fuel pressure NEVER drops below 11 inches water column for natural gas or 11 inches water column for liquid propane for all load ranges.**

#### NOTE:

**It is the responsibility of the installer to make sure that only the correct recommended fuel is supplied to the generator fuel system. Thereafter, the owner/operator must make certain that only the proper fuel is supplied.**

### ◆ NATURAL GAS FUEL SYSTEM

Natural gas is supplied in its vapor state. In most cases, the gas distribution company provides piping from the main gas distribution line to the standby generator site. The following information applies to natural gas fuel systems.

- Gas pressure in a building is usually regulated by national, state and local codes.
- To reduce gas pressure to a safe level before the gas enters a building, a primary regulator is needed. The natural gas supplier may or may not supply such a regulator.
- It is the responsibility of the gas supplier to make sure sufficient gas pressure is available to operate the primary regulator.
- Gas pressure at the inlet to the fuel shutoff solenoid should not exceed approximately 14 inches water column (0.5 psi). Optimum pressure at the fuel shutoff solenoid is 11 inches water column (0.4 psi).

### ◆ PROPANE VAPOR WITHDRAWAL FUEL SYSTEM

This type of system utilizes the vapors formed above the liquid fuel in the supply tank. Approximately 10 to 20 percent of the tank capacity is needed for fuel expansion from the liquid to the vapor state. The vapor withdrawal system is generally best suited for smaller engines that require less fuel. The installer should be aware of the following:

- The natural gas and LP gas systems are similar. However, the natural gas system delivers gas at a pressure of approximately five inches water column to the carburetor.
- When ambient temperatures are low and engine fuel consumption is high, the vapor withdrawal system may not function efficiently.
- Ambient temperatures around the supply tank must be high enough to sustain adequate vaporization, or the system will not deliver the needed fuel volume.
- In addition to the cooling effects of ambient air, the vaporization process itself provides an additional cooling effect.

### ◆ LP FUEL SYSTEM

LP is supplied as a liquid in pressure tanks. It is usually made up of propane, butane, or a mixture of the two gases. Propane tends to vaporize readily even at temperatures as low as -20° F (-29° C). However, butane reverts to its liquid state when temperatures drop below 32° F (0° C).

LP in a liquid withdrawal system must be converted to its gaseous state before it is introduced into the engine carburetor. A vaporizer-converter is generally used to accomplish this. In such a converter, heated engine coolant is ported through the converter to provide the necessary heat for conversion of the fuel from a liquid to a gaseous state.

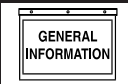

# Standby Generator Sets Specifications

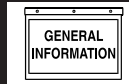

## SPECIFICATIONS

### ◆ GENERATOR

Type ..... Synchronous  
 Rotor Insulation ..... Class H  
 Stator Insulation ..... Class H  
 Total Harmonic Distortion ..... < 3.5%  
 Telephone Interference Factor (TIF) ..... < 50  
 Alternator Output Leads 3-phase ..... 6-wire  
 Bearings ..... Sealed Ball  
 Coupling ..... Flexible Disc  
 Load Capacity (Standby Rating) ..... 100kW\*

\* NOTE: Generator rating and performance in accordance with ISO8528-5, BS5514, SAE J1349, ISO3046 and DIN 6271 Standards. KW rating is based on LPG fuel and may derate with natural gas.

Excitation System ..... Brushless  
 Generator Output Voltage/kW - 60 Hz

	<u>kW</u>	<u>Amp</u>	<u>CB Size</u>
120/240V, 1-phase, 1.0 pf	100	417	500
120/208V, 3-phase, 0.8 pf	100	347	400
277/480V, 3-phase, 0.8 pf	100	150	200

Generator Locked Rotor KVA Available @ Voltage Dip of 35%  
 Single-phase or 208 3-phase ..... 190 KVA  
 480V, 3-phase ..... 225 KVA

### ◆ ENGINE

Make ..... Generac  
 Model ..... V-type  
 Cylinders and Arrangement ..... 8  
 Displacement ..... 5.4 Liter  
 Bore ..... 3.55 in.  
 Stroke ..... 4.17 in.  
 Compression Ratio ..... 9-to-1  
 Air Intake System ..... Naturally Aspirated  
 Valve Seats ..... Hardened  
 Lifter Type ..... Hydraulic

#### Engine Parameters

Rated Synchronous RPM ..... 60 Hz, 3600  
 HP at rated kW ..... 60 Hz, 175

#### Exhaust System

Exhaust Flow at Rated Output 60 Hz ..... 953 cfm  
 Exhaust Temperature at Rated Output ..... 1000° F

#### Combustion Air Requirements (Natural Gas)

Flow at rated power, 60 Hz ..... 325 cfm

#### Governor

Type ..... Electronic  
 Frequency Regulation ..... Isochronous  
 Steady State Regulation ..... ± 1/2%  
 Adjustments:  
 Speed ..... Selectable

### Engine Lubrication System

Type of Oil Pump ..... Gear  
 Oil Filter ..... Full Flow, Cartridge  
 Crankcase Oil Capacity ..... 5 U.S. qts.

### ◆ COOLING SYSTEM

Type ..... Closed  
 Water Pump ..... Belt Driven  
 Fan Speed ..... 1700  
 Fan Diameter ..... 26 inches  
 Fan Mode ..... Puller  
 Air Flow (inlet air including alternator and combustion air) ..... 4800 ft<sup>3</sup>/min.  
 Coolant Capacity ..... (4.0 U.S. gal.)  
 Heat Rejection to Coolant ..... 376,000 Btu/h  
 Maximum Operating Air Temp. on Radiator ..... 60° C (150° F)  
 Maximum Ambient Temperature ..... 50° C (140° F)

### ◆ FUEL SYSTEM

Type of Fuel ..... Natural Gas  
 Carburetor ..... Down Draft  
 Secondary Fuel Regulator ..... Standard  
 Fuel Shut-off Solenoid ..... Standard  
 Operating Fuel Pressure ..... 11 in. - 14 in. Water Column

#### Fuel Consumption - ft<sup>3</sup>/hr (Natural Gas/LPV)

<i>Exercise Cycle</i>	<i>25% Load</i>	<i>50% Load</i>	<i>75% Load</i>	<i>100% Load</i>
140/56	371/149	713/287	994/400	1374/553

\* Engine is not field convertible between natural gas and propane. Jet size and ignition timing are factory set for the specific fuel.

### ◆ ELECTRICAL SYSTEM

Battery Charge Alternator ..... 12V, 30 Amp  
 Static Battery Charger ..... 12V, 2 Amp  
 Recommended Battery ..... 24F 525CCA  
 System Voltage ..... 12 Volts

#### Voltage Regulator

Type ..... Full Digital  
 Sensing ..... 3-phase  
 Regulation ..... ± 1/4%  
 Features ..... Built into H-100 Control Panel  
 V/F Adjustable, Adjustable  
 Voltage and Gain

#### Power Adjustment for Ambient Conditions

Temperature Deration  
 3% for every 10° C above °C ..... 25  
 1.65% for every 10° above °F ..... 77  
 Altitude Deration  
 1% for every 100 m above m ..... 183  
 3% for every 1000 ft. above ft. .... 600

Controller ..... H-panel

Figure 1 — Interconnections

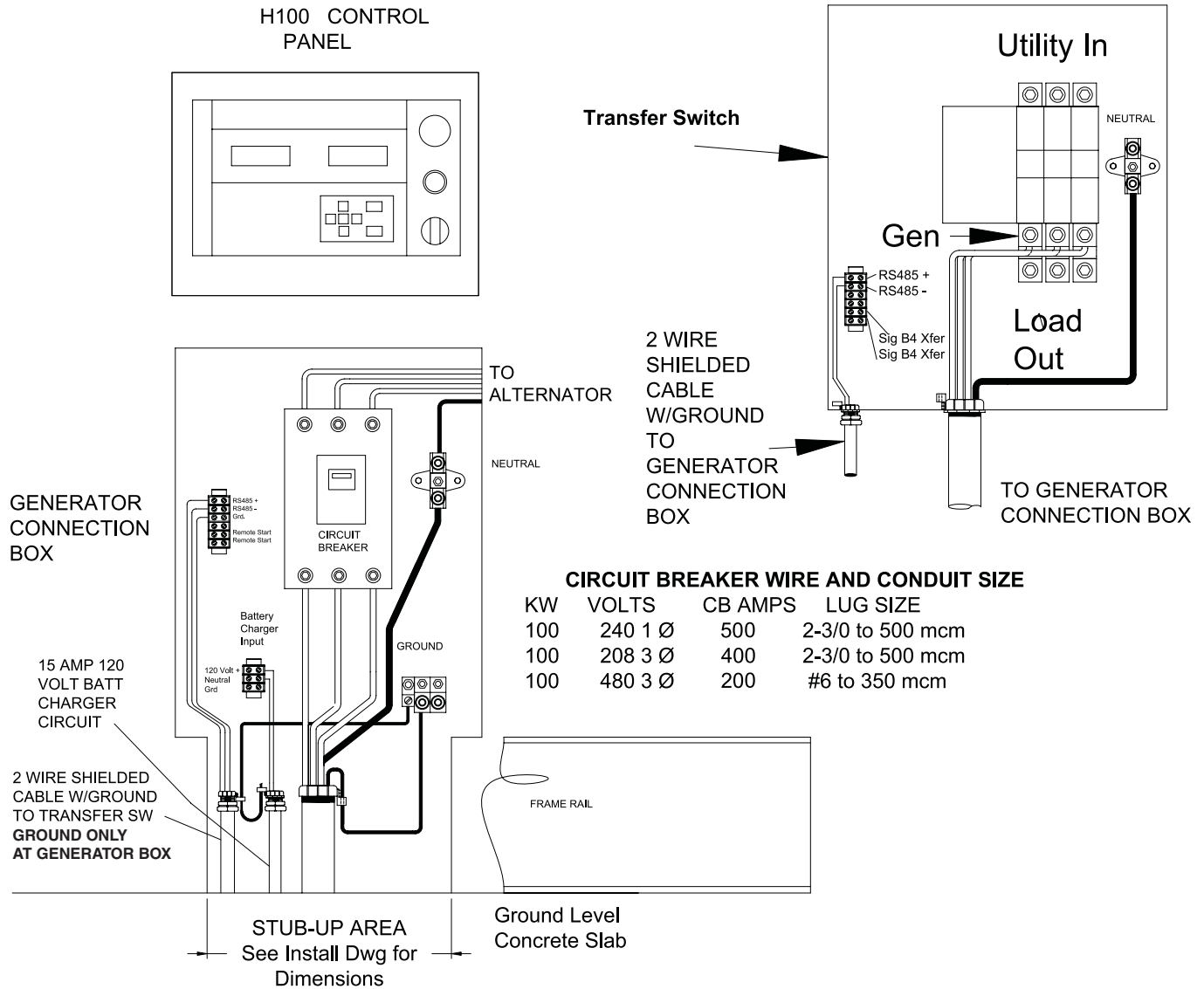

## ◆ COLD WEATHER KIT

For cold climates, optional cold weather kit (part number 0F6148A) is recommended. The kit includes:

- Battery Warmer
- 4" Junction Box with hardware
- Thermostat; 20 deg "ON", 40 deg "OFF"
- 6 qt. pack 5W-30 synthetic oil (engine)

## 5.4L & 6.8L IGNITION DESCRIPTION

This single-fire Ignition is intended to operate with a 10-cylinder, 6.8L engine and an 8-cylinder, 5.4L engine.

The 6.8L engine uses a 40-1 crank sensor, a mag-pickup CAM sensor and individual coil-on-plug coils for each spark-plug.

The 5.4L engine uses a 36-1 crank sensor, a mag-pick-up CAM sensor and individual coil-on-plug coils for each spark-plug.

With a single-fire ignition, each high-voltage coil output is connected to one spark plug resulting in that spark plug being fired only during the compression cycle.

**Engine Timing versus Engine Speed for the 6.8L engine is:**

RPM	NG/LP Engine Timing (BTDC)
1800 rpm	22 degrees
3600 rpm	24 degrees

**Engine Timing versus Engine Speed for the 5.4L engine is:**

RPM	NG/LP Engine Timing (BTDC)
1800 rpm	26 degrees
3600 rpm	26 degrees

### ◆ IGNITION POWER-UP INPUT ("56 LINE INPUT")

When battery voltage is applied to this input the ignition will power-up. For the ignition to power itself down, battery voltage must be removed from this input.

### ◆ IGNITION ENABLE ("14 LINE INPUT")

This input must be connected to the +12V battery for the ignition to turn-on the coils. If this input is connected to battery ground the ignition will stop firing the coils and will power down within approximately 2 seconds. In the event that an ignition fault has occurred, however, the ignition will wait 60 seconds before powering down. This allows time to view the diagnostic LED located on the ignition board.

#### NOTE:

**The ignition cover does not need to be removed to see the LED.**

### ◆ IGNITION SHUTDOWN ON LOSS OF CRANK OR CAM SIGNALS

The ignition will stop firing the coils immediately following the loss of the crank signal. The ignition will stop firing the coils after approx. 3 seconds following the loss of the cam signal.

### ◆ DIAGNOSTIC BLINK PATTERNS (RED LED LOCATED ON THE IGNITION CONTROL BOARD)

During normal ignition operation the RED LED flashes at a 0.5 sec ON and a 0.5 sec OFF rate. This is considered one (1) blink.

LED Fault Code with Priority as shown:

1. No Crank Signal: LED blinks 2 times, is OFF for 3.0 seconds and then repeats
2. No CAM Signal: LED blinks 3 times, is OFF for 3.0 seconds and then repeats

Only one fault is displayed at a time. If multiple faults exist then the highest priority fault must be resolved prior to a lower priority fault being displayed. In the event that an ignition fault has occurred the ignition will wait 60 seconds before powering down.

#### NOTE:

**The ignition cover does not need to be removed to see the LED.**

## GENERATOR AC LEAD CONNECTIONS

See "Voltage Codes". This generator may be rated at any one of three voltages, either single-phase or three-phase. The electrical wires in the unit's AC connection (lower) panel should be installed according to the number of leads and the voltage/phase required for the application. If there are any questions regarding lead connection, refer to the wiring diagrams at the back of this manual.

Voltage codes apply to the type of stator assembly installed on a particular generator.

### ◆ FOUR-LEAD, SINGLE-PHASE STATOR

Four-lead generators (see Figure 7.1) are designed to supply electrical loads with voltage code "A" (240V, 1-phase, 60 Hz). Electrical power is produced in the stator power windings. These windings were connected at the factory to the main circuit breaker as shown in Figure 7.1.

The rated voltage between each circuit breaker terminal is 240V. The rated voltage between each circuit breaker terminal and the neutral point 00 is 120V.

Figure 7.1 — Four-lead, Single-phase Stator

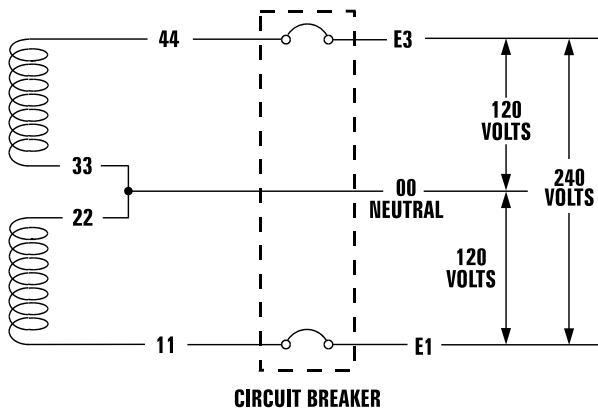

## ALTERNATOR POWER WINDING CONNECTIONS

### ◆ 3-PHASE ALTERNATORS

The generator is designed to supply 3-phase electrical loads. Electric power is produced in the alternator power windings. These windings were connected at the factory to the main circuit breaker with a "Y" configuration as shown in Figures 7.2 and 7.3.

The rated voltage between circuit breaker terminals E1-E2, E1-E3 and E2-E3 is either 480V or 208V depending on the model.

The rated voltage between each circuit breaker terminal and the neutral point 00 is either 277V or 120V depending on the model.

Figure 7.2 — Stator Power Winding Connections - 3-phase, 277/480V (6 Lead)

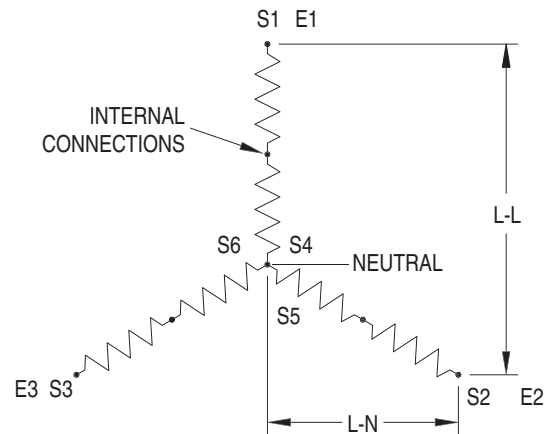
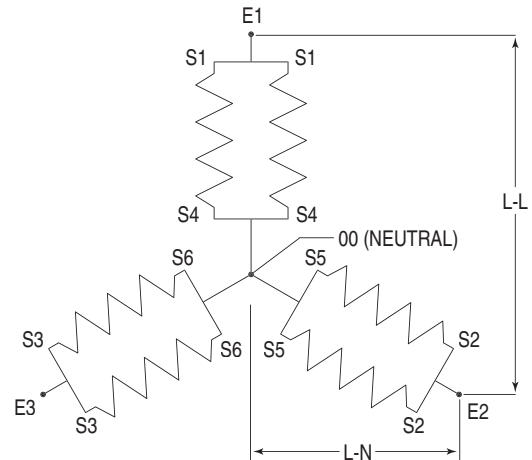

Figure 7.3 — Stator Power Winding Connections - 3-phase, 120/208V (6 Lead)





## INSTALLATION

Refer to the separate “Installation Guide” supplied with the unit.

## PREPARATION BEFORE START-UP

The instructions in this section assume that the standby generator has been properly installed, serviced, tested, adjusted and otherwise prepared for use by a competent, qualified installation contractor. Be sure to read the “Safety Rules”, as well as all other safety information in this manual, before attempting to operate this (and related) equipment.

Before starting the generator for the first time, the installer must complete the following procedures. For follow-up maintenance information and/or service intervals, please refer to the “Maintenance” section and the “Service Schedule”.

### ◆ TRANSFER SWITCH

If this generator is used to supply power to any electrical system normally powered by an electric utility, the National Electrical Code requires that a transfer switch be installed. The transfer switch prevents electrical backfeed between two different electrical systems. (For additional information, see the applicable transfer switch manual for this unit.) The transfer switch, as well as the generator and other standby components, must be properly located and mounted in strict compliance with applicable codes, standards and regulations.

### ◆ FUEL SYSTEM

Make sure the fuel supply system to the generator (a) delivers the correct fuel at the correct pressure and (b) is properly purged and leak tested according to code. No fuel leakage is permitted. See “Specifications” for more information.

### ◆ GENERATOR SET LUBRICATION

Check the engine crankcase oil level before operating and add oil to the proper level – the dipstick “FULL” mark. Never operate the engine with the oil level below the dipstick “ADD” mark. See “Specifications” and “Engine Oil Recommendations”.

#### NOTE:

**This engine is shipped from the manufacturer with “break-in” oil. This oil should be changed after 30 hours of operation.**

## ◆ PRIOR TO INITIAL START-UP



- ⚠ Prior to initially starting the generator, it must be properly prepared for use. Any attempt to crank or start the engine before it has been properly serviced with the recommended types and quantities of engine fluids (oil, coolant, fuel, etc.) may result in an engine failure.

### ◆ ENGINE COOLANT

Have the engine cooling system properly filled with the recommended coolant mixture. Check the system for leaks and other problems. See “Specifications” and “Coolant” sections.

### ◆ BELT TENSION

Check the engine-fan belt tension and condition prior to placing the unit into service and at recommended intervals. Belt tension is correct when a force of approximately 22 pounds (10 kg), applied midway between pulleys, deflects the belt about 3/8- to 5/8-inch (10 to 16 mm).

### ◆ ELECTRICAL SYSTEM

Make sure the generator is properly connected to an approved earth ground.

Make sure the generator battery is fully charged, properly installed and interconnected, and ready for use.

#### NOTE:

**Battery charger must be connected to 120 VAC, 15 amp circuit to operate.**

Check to ensure that there are no loose electrical connections. Restrain any loose wires to keep them clear of any moving generator set components.

## INITIAL INSPECTION FOR GENSET STARTUP

**Inspect for the following.**

- Freight Damage.
- Manuals present.
- Fluid Levels (Oil, coolant, battery, Gear Drive).
- Correct fuel piping.
- Adequate air flow, clearances and ventilation per installation drawings and applicable codes.
- Correct AC and DC wire size, connections and grounding. Control and communication wiring to/from the transfer switch must be run in a separate conduit from the AC power leads.



- **Battery charger connection to 120 VAC.**
- Communication wires connected between transfer switch and generator (HTS only).
- Unit secured to pad.

## START-UP CHECKLIST



### WARNING

**⚠ Before working on the generator, ensure the following:**

- **The AUTO/OFF/MANUAL switch is in the OFF position.**
- **The 120VAC supply to the battery charger is switched OFF.**

### ◆ PREPARATION FOR START-UP

- Ensure that the 120VAC circuit breaker to the battery charger is open.
- Remove the fuse from the the control panel. Open the front door of the control box and remove the 15 Amp ATO fuse in the lower left-hand corner of the control box.
- Connect the battery cables to the battery. Attach negative battery cable last.
- Close the 120VAC circuit breaker to the battery charger.
- Measure the voltage at the battery before and after the charger is turned on.
- Verify all AC electrical connections are tight at the circuit breaker and transfer switch.
- Visually inspect entire area looking for loose paper, plastic wrappings, leaves, etc.
- Check all hoses clamps fittings for leaks or damage.
- Check all electrical plugs throughout the generator. Ensure each plug is seated correctly and fully inserted into its receptacle.
- Verify the AUTO/OFF/MANUAL switch is in OFF position.
- Open the valve to the engine fuel line.
- Bleed the fuel system of air. (necessary for long fuel lines).
- Open the generator main line circuit breaker.
- Connect a manometer to the gas line and record the static pressure. It must be as listed in the Specifications.
- Insert the fuse into the control panel.
- Move the AUTO/OFF/MANUAL switch to the manual position. The engine should now crank and start.
- Check voltage at the generator terminals.
- For 3-phase units, check phase rotation at the transfer switch terminals. The generator phase rotation must match the utility phase rotation.
- Check for coolant, fuel, oil, and exhaust leaks.
- Close the generators main line circuit breaker.
- Turn the generator set off.
- Connect the UTILITY supply to the transfer switch.
- Set the AUTO/OFF/MANUAL switch to AUTO.
- Disconnect utility power before the transfer switch.
  - Engine should start, transfer to load.
  - Run at least 15 minutes on generator power. Make certain all 3-phase loads are functioning correctly (correct phase rotation).
- Reconnect Utility power
  - Transfer switch will transfer back to Utility and engine will shut down within the given time parameters set up for the specific transfer switch and controller.
- Install all covers, access plates and door panels.
- Put the Owners Manual in a safe and accessible place.
- Make certain the AUTO/OFF/MANUAL switch is in the AUTO position.

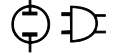
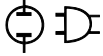

## GENERATOR CONTROL AND OPERATION

Refer to the appropriate control panel operator's manual for this unit.

## OPERATING UNIT WITH MANUAL TRANSFER SWITCH

If the generator was installed in conjunction with a transfer switch capable of manual operation only, the following procedure applies. A manually operated transfer switch is one that will not provide automatic start-up and does not include an intelligence circuit.

### ◆ ENGINE START-UP AND TRANSFER

For additional information, refer to the applicable control panel manual for this unit, as well as any literature pertaining to the specific transfer switch.



⚠ The Maintenance Disconnect Switch and the AUTO/OFF/MANUAL switches (if so equipped) must be set properly, or the generator will crank and start as soon as the utility power to the transfer switch is turned off. Refer to applicable control panel and transfer switch manuals for more information.

⚠ Do not proceed until certain that utility source voltage is available to the transfer switch and the transfer switch main contacts are set to UTILITY.

⚠ Do not attempt manual operation until all power supplies to the transfer switch have been positively turned off, or extremely dangerous - possibly lethal - electrical shock will result.

⚠ Transfer switch enclosure doors should be kept closed and locked. Only authorized personnel should be allowed access to the transfer switch interior. Extremely high and dangerous voltages are present in the transfer switch.

In order to transfer load from the utility source to the generator, follow these directions:

- Turn OFF or disconnect the utility power circuit to the transfer switch, using the means provided (such as the utility source main line circuit breaker).
- Set the transfer handle to its UTILITY (NORMAL) position with load circuits connected to the utility power supply.
- Set the standby generator's main line circuit breaker to its OFF (or OPEN) position.
- Start the generator.



⚠ Do not crank the engine continuously for longer than 30 seconds, or the heat may damage the starter motor.

- Let engine stabilize and warm up.
- Check all applicable instrument and gauge readings. When certain that all readings are correct, move the transfer switch manual handle to its STANDBY (GENERATOR) position, i.e., load circuits supplied by the generator.
- Set the standby generator's main line circuit breaker to its ON (or CLOSED) position.
- Load circuits are now powered by the standby generator.

### ◆ RETRANSFER AND SHUTDOWN

For additional information, refer to the applicable control panel manual for this unit, as well as any literature pertaining to the specific transfer switch.

To transfer the load back to the utility power source and shut down the generator, follow these directions:

- Set the standby generator's main line circuit breaker to its OFF (or OPEN) position.
- Manually move the transfer switch handle to its UTILITY (NORMAL) position, i.e., load circuits connected to the utility.
- Turn ON the utility power supply to the transfer switch, using the means provided (such as the utility power source main line circuit breaker).
- Let the generator run at no-load for a few minutes to stabilize internal temperatures.
- Shut down the generator.

## OPERATING UNIT WITH AUTOMATIC TRANSFER SWITCH

If the generator has been installed with an automatic transfer switch, such as an RTS, HTS, or GTS-type transfer switch, the engine may be started and stopped automatically or manually.

### NOTE:

**Refer to the applicable manual for your transfer switch and to "Transfer Switch Start Signal Connections". In addition, please note the dangers under "Engine Start-up and Transfer."**





## MAINTENANCE PERFORMED BY AUTHORIZED SERVICE FACILITIES

### —▲ WARNING ▲—

▲ Before working on the generator, ensure the following:

- The **AUTO/OFF/MANUAL** switch is in the **OFF** position.
- The **15A** fuse has been removed from the control box.
- The **120VAC** supply to the battery charger is switched **OFF**.

### ◆ EVERY THREE MONTHS

1. Check battery state of charge and condition.
2. Inspect and test fuel system.
3. Check transfer switch.
4. Inspect exhaust system.
5. Check engine ignition system.
6. Check fan belts.

### ◆ ONCE EVERY SIX MONTHS

1. Test Engine Safety Devices (low oil pressure, low coolant level, high coolant temperature).

### ◆ ONCE ANNUALLY

1. Test engine governor. Adjust or repair, if needed.
2. Clean, inspect generator.
3. Flush cooling system.

### ◆ FIRST 30 OPERATING HOURS

1. Change engine "break-in" oil and oil filter.

### ◆ FIRST 100 OPERATING HOURS

1. Change engine oil and oil filter. (After initial change, service engine oil and filter at 150 operating hours or 6 months, whichever comes first.)

### ◆ EVERY 500 OPERATING HOURS

1. Service air cleaner.
2. Check starter.
3. Check engine DC alternator.

## COOLING SYSTEM

Air intake and outlet openings in the generator compartment must be open and unobstructed for continued proper operation. This includes such obstructions as high grass, weeds, brush, leaves and snow.

Without sufficient cooling and ventilating air flow, the engine/generator quickly overheats, which causes it to shut down.

### —▲ WARNING ▲—

▲ The exhaust system parts from this product get extremely hot and remain hot after shutdown. High grass, weeds, brush, leaves, etc. must remain clear of the exhaust. Such materials may ignite and burn from the heat of the exhaust system.

## CHECKING FLUID LEVELS

### ◆ CHECK ENGINE OIL

Check engine crankcase oil level (Figure 10.1) at least every 20 hours of operation, or prior to use.

- Remove oil dipstick and wipe dry with a clean, lint-free cloth.
- Install oil dipstick, then remove again.
- Oil should be between **FULL** and **ADD** marks.
- If oil level is below the dipstick **ADD** mark, remove oil fill cap. Add the recommended oil to bring oil level up to the **FULL** mark. **DO NOT FILL ABOVE THE "FULL" MARK.** See "Engine Oil Recommendations" for recommended oils.

Figure 10.1 - Oil Dipstick and Oil Fill Cap

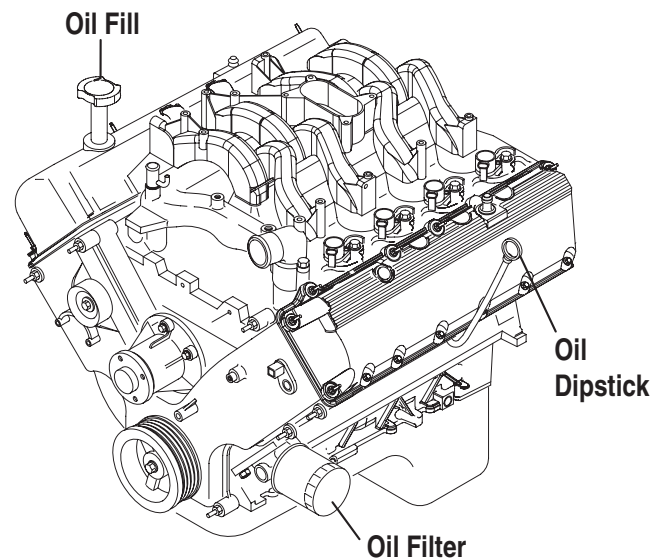

### ◆ BATTERY FLUID

Check battery electrolyte fluid at least once weekly. Fluid should cover separators in all battery cells. If fluid level is low, add distilled water to cover tops of separators. **DO NOT USE TAP WATER IN BATTERY.**



### ◆ ENGINE COOLANT

Check coolant level in coolant recovery bottle. See the “Specifications” section.

- Add recommended coolant mixture as necessary.
- Periodically remove radiator pressure cap to make sure the coolant recovery system is functioning properly. Coolant should be at bottom of radiator filler neck. If coolant level is low, inspect gasket in radiator pressure cap. Replace cap, if necessary. To have pressure cap tested, contact an Authorized Service Dealer. Inspect cooling system and coolant recovery system for leaks.

## MAINTENANCE OWNER/ OPERATOR CAN PERFORM

### ◆ CHECK ENGINE OIL LEVEL

Refer to the “Checking Fluid Levels” section.

### ◆ CHECK BATTERY

- Check battery fluid level each week as outlined under “Check Fluid Levels”.
- Check battery cables for condition, tightness, corrosion or damage. Clean, tighten or replace as necessary.

### ◆ EXERCISE SYSTEM

Start the generator engine at least once every seven days and let it run at least 20 minutes. For more detailed exercise information, see the respective sections in the Control Panel Technical Manual that is supplied with the unit.

### ◆ INSPECT COOLING SYSTEM

- Inspect engine cooling system at least once each month.
- Check hoses for damage, deterioration, leaks, etc. Correct any discrepancies found.
- Check hose clamps for tightness.

### ◆ CHECK ENGINE COOLANT LEVEL

See the “Checking Fluid Levels” section.

### ◆ PERFORM VISUAL INSPECTION

Complete a thorough visual inspection of the entire engine-generator monthly. Look for obvious damage, loose, missing or corroded nuts, bolts and other fasteners. Look for fuel, oil or coolant leaks.

### ◆ INSPECT EXHAUST SYSTEM

Inspect the exhaust system at least once every three months. Check all exhaust system pipes, mufflers, clamps, etc. for condition, tightness, leaks, security, damage.

### ◆ CHECK FAN BELT

- Inspect fan belts every three months. Replace any damaged, deteriorated, worn or otherwise defective belt.
- Check fan belt tension. Thumb pressure, exerted midway between pulleys, should deflect about 3/8 to 5/8 inch. Adjust belt tension as required.

### ◆ INSPECT ENGINE GOVERNOR

Visually inspect electronic governor.



-  Do not attempt to adjust the governor. Only qualified service facilities should adjust the governor. Excessively high operating speeds are dangerous and increase the risk of personal injury. Low speeds impose a heavy load on the engine when adequate engine power is not available and may shorten engine life. Correct rated frequency and voltage are supplied only at the proper governed speed. Some connected electrical load devices may be damaged by incorrect frequency and/or voltage. Only qualified service technicians should adjust the governed speed.

### ◆ CHANGING ENGINE OIL

Refer to maintenance performed by authorized service facilities for engine oil and filter change frequencies.

Drain the oil while the engine is still warm from running. This means warm up the engine, shut it down and drain immediately as follows:

1. Remove OIL DRAIN HOSE from its retaining clip.
2. Loosen and remove OIL DRAIN HOSE CAP. Drain oil completely into suitable container.
3. When all oil has drained, install and tighten OIL DRAIN HOSE CAP, and re-install into its retaining clip.
4. Turn OIL FILTER (Figure 10.2) counterclockwise and remove. Dispose of old filter.
5. Apply light coating of new engine oil to seal of new oil filter. -Install FILTER and tighten by hand only. DO NOT OVERTIGHTEN.
6. Remove OIL FILL CAP. Add recommended oil (see SPECIFICATIONS). DO NOT FILL ABOVE THE DIPSTICK “FULL” MARK. Crankcase oil capacity is listed in the “Specifications”.

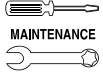

## CAUTION

⚠ After refilling the crankcase with oil, always check oil level on dipstick. **NEVER OPERATE ENGINE WITH OIL BELOW THE DIPSTICK "ADD" MARK.**

7. Start engine and check for oil leaks.

**Figure 10.2 - Oil Filter**

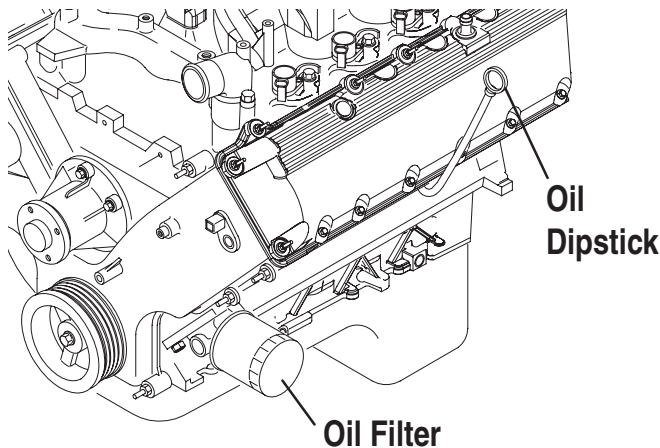

## ◆ CHANGING THE ENGINE AIR CLEANER

To replace the engine air cleaner, (part number 0A4637), remove the air cleaner cover and replace the air filter making sure it is positioned properly before reattaching the cover.

**Figure 10.3 — Engine Air Filter**

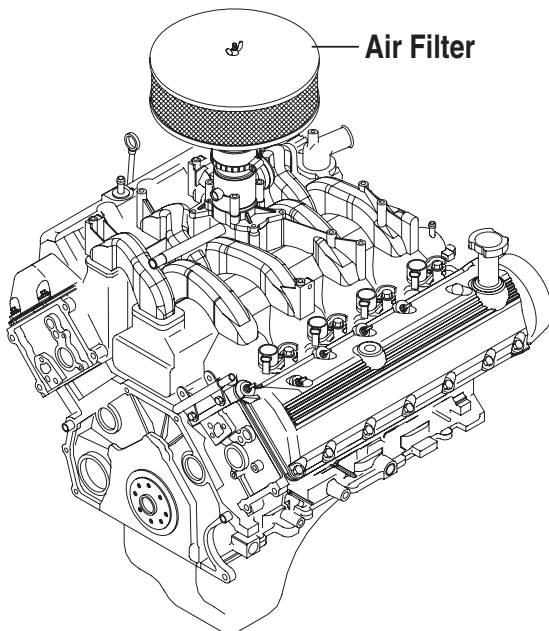

See the "Service Schedule" section for air cleaner maintenance.

## ◆ SPARK PLUGS

Reset the spark plug gap or replace the spark plugs as necessary.

1. Clean the area around the base of the spark plugs to keep dirt and debris out of the engine. Clean by scraping or washing using a wire brush and commercial solvent. Do not blast the spark plugs to clean.
2. Remove the spark plugs and check the condition. Replace the spark plugs if worn or if reuse is questionable. See the "Service Schedule" section for recommended inspection.
3. Check the spark plug gap using a wire feeler gauge. Adjust the gap to 1.14 mm (0.045 inch) by carefully bending the ground electrode (Figure 10.4).

**Figure 10.4 – Setting the Spark Plug Gap**

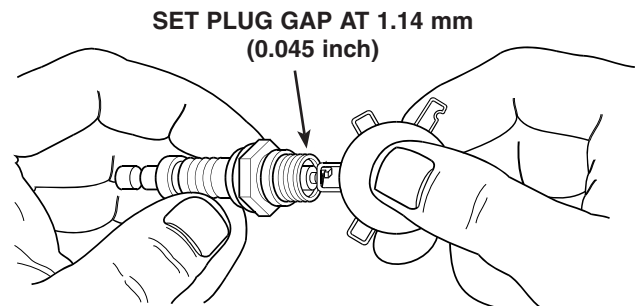

## ◆ COOLANT CHANGE

Every year, have an Authorized Service Facility drain, flush and refill the cooling system. See the "Specifications" section for cooling system recommendations.

## MISCELLANEOUS MAINTENANCE

### ◆ CLEANING THE GENERATOR

Keep the generator as clean and as dry as possible. Dirt and moisture that accumulates on internal generator windings have an adverse effect on insulation resistance.

Periodically clean generator exterior surfaces. A soft brush may be used to loosen caked on dirt. Use a vacuum system or dry, low pressure air to remove any accumulations of dirt. The generator is housed inside an all-weather enclosure, clean the enclosure with a soft, damp cloth or sponge and water.

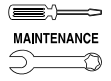

Once each year, have the generator cleaned and inspected by an Authorized Service Dealer. That dealer will use dry, low pressure air to clean internal windings. Parts inside the control console should be cleaned and inspected at this time as well.

Finally, have the insulation resistance of stator and rotor windings checked. If insulation resistances are excessively low, the generator may require drying.

### ◆ BATTERY

All lead-acid storage batteries discharge when not in use. Refer to specific instructions and warnings that accompany the battery. If such information is not available, observe the following precautions when handling a battery:

- DO NOT use jumper cables and a booster battery to crank or start the generator engine.
- DO NOT recharge a weak battery while it is installed in the generator. Remove battery from generator and recharge in a well-ventilated area, away from fuel vapors, sparks, heat or flames.
- Battery electrolyte fluid is an extremely caustic sulfuric solution that can cause severe burns. DO NOT permit fluid to contact eyes, skin, clothing, painted surfaces, wiring insulation, etc. If any battery fluid is spilled, flush the affected area with clear water immediately.
- Always wear safety glasses, rubber apron and gloves when handling a battery.
- Batteries give off explosive hydrogen gas while charging. The gas can form an explosive mixture around the battery for several hours after charging. Any spark, heat or flames can ignite the gas and cause an explosion which can shatter the battery, causing blindness or other serious injury.

### ◆ BATTERY MAINTENANCE

The battery should be inspected per the “Service Schedule” section. The following procedure should be followed for inspection:

1. Inspect the battery posts and cables for tightness and corrosion. Tighten and clean as necessary.
2. Check the battery fluid level of unsealed batteries and, if necessary, fill with DISTILLED WATER ONLY. DO NOT USE TAP WATER IN BATTERIES.
3. Have the state of charge and condition checked. This should be done with an automotive-type battery hydrometer.

### —▲ DANGER ▲—

▲ Storage batteries give off explosive hydrogen gas. This gas can form an explosive mixture around the battery for several hours after charging. The slightest spark can ignite the gas and cause an explosion. Such an explosion can shatter the battery and cause blindness or other injury. Any area that houses a storage battery must be properly ventilated. Do not allow smoking, open flame, sparks or any spark producing tools or equipment near the battery.

▲ Battery electrolyte fluid is an extremely caustic sulfuric acid solution that can cause severe burns. Do not permit fluid to contact eyes, skin, clothing, painted surfaces, etc. Wear protective goggles, protective clothing and gloves when handling a battery. If the fluid is spilled, flush the affected area immediately with clear water.

▲ Do not use any jumper cables or booster battery to crank and start the generator engine. If the battery has completely discharged, remove it from the generator for recharging.

### —▲ WARNING ▲—

▲ Be sure the AUTO/OFF/MANUAL switch is set to the OFF position before connecting the battery cables. If the switch is set to AUTO or MANUAL, the generator can crank and start as soon as the battery cables are connected.

▲ Be sure the 120VAC power supply to the battery is turned OFF, or sparking may occur at the battery posts as the cables are attached and cause an explosion.

### ◆ BATTERY REPLACEMENT

When replacing batteries, use the same number and type of battery that was supplied with the unit, and is listed in the parts list in the back of this manual.

#### NOTE:

**The BCI number should be located directly on the battery.**

### REPAIR PARTS

The latter portion of this manual consists of exploded views, parts lists and electrical data pertaining to this generator set. The parts lists consist of (a) an item number, (b) a part number, (c) the quantity required, and (d) a description of the part. The item number corresponds to an identical number on the exploded view drawing.



## Standby Generator Sets Service Schedule



### SERVICE SCHEDULE

#### 30 KW - 150 KW STANDBY GAS ENGINE DRIVEN GENERATOR SETS

The following is a recommended maintenance schedule for standby gas engine driven generator sets from 30kW to 150 kW in size. The established intervals in the schedule are the maximum recommended when the unit is used in an average service application. They will need to be decreased (performed more frequently) if the unit is used in a severe application. Use calendar time, from the previous maintenance interval to determine the next required maintenance interval.

#### Service Maintenance Interval Information:

The various service maintenance intervals are designated by interval numbers as follows:

- 1 An early inspection of the generator set to insure it is ready to operate when required and to identify any potential problem areas.

*This inspection may be performed by the end user providing the following safety steps are taken to prevent the engine from starting automatically without warning:*

**To prevent injury, perform the following steps in the order indicated before starting any maintenance:**

- **Disable the generator set from starting and/or connecting to the load by setting the control panel Auto/Off/Manual switch to the “OFF” position.**
- **Remove the 15 amp control panel fuse.**
- **Turn off the battery charger.**
- **Remove the negative battery cable.**

**The battery charger must be turned off BEFORE removing the battery cable to prevent an over current condition from burning out sensitive control panel components and circuits.**

**Following all maintenance, reverse these steps to insure the unit is returned to standby setup for normal operation when required.**

- 2 A wear-in service inspection of the generator set to insure it is ready to operate and carry the load when required, and to identify any potential problem areas.

*Performed **ONLY ONCE** following the first three months or the first 30 hours of operation after purchase of the unit.*

*This inspection contains some maintenance tasks which require special tools, equipment, and/or knowledge to accomplish and should be performed only by an Authorized Service Dealer.*

- 3 An operational inspection of the generator set to insure it is ready to operate and carry the load when required, and to identify any potential problem areas.

*Performed semi-annually or following each 50 hours of operation of the unit.*

*This inspection contains some maintenance tasks which require special tools, equipment, and/or knowledge to accomplish and should be performed only by an Authorized Service Dealer.*

- 4 A mid-level inspection of the generator set to insure it is ready to operate and carry the load when required, and to identify any potential problem areas.

*Performed annually or following each 100 hours of operation of the unit.*

*This inspection contains some maintenance tasks which require special tools, equipment, and/or knowledge to accomplish and should be performed only by an Authorized Service Dealer.*

- 5 A comprehensive inspection of the generator set to insure it is properly serviced and ready to operate and carry the load when required, and to identify any potential problem areas.

*Performed annually or following each 250 hours of operation of the unit.*

*This inspection contains some maintenance tasks which require special tools, equipment, and/or knowledge to accomplish and should be performed only by an Authorized Service Dealer.*



## Standby Generator Sets Service Schedule



Maintenance Tasks	Level 1	Task Comp. (Date-Initials)	Level 2	Task Comp. (Date-Initials)	Level 3	Task Comp. (Date-Initials)	Level 4	Task Comp. (Date-Initials)	Level 5	Task Comp. (Date-Initials)
	Recommended to be done monthly/ 10 hrs.		Required to be done 3 months/ Break-in 30 hrs.		Required to be done Semi-annually/ 50 hrs.		Required to be done Annually/ 100 hrs.		Required to be done Bi-annually/ 250 hrs.	
1. Disable the unit from operating per the first page warning.	<input type="checkbox"/>		<input type="checkbox"/>		<input type="checkbox"/>		<input type="checkbox"/>		<input type="checkbox"/>	
2. Check the engine oil level. Adjust as necessary.	<input type="checkbox"/>		<input type="checkbox"/>		<input type="checkbox"/>		<input type="checkbox"/>		<input type="checkbox"/>	
3. Check the engine coolant level. Adjust as necessary.	<input type="checkbox"/>		<input type="checkbox"/>		<input type="checkbox"/>		<input type="checkbox"/>		<input type="checkbox"/>	
4. Check the engine coolant thermal protection level. Correct as necessary.							<input type="checkbox"/>		<input type="checkbox"/>	
5. Check the natural gas delivery system for leaks and correct pressure on gas engine driven units. Tighten connections as necessary.	<input type="checkbox"/>		<input type="checkbox"/>		<input type="checkbox"/>		<input type="checkbox"/>		<input type="checkbox"/>	
6. Check the air inlets and outlets for debris. Clean as necessary.	<input type="checkbox"/>		<input type="checkbox"/>		<input type="checkbox"/>		<input type="checkbox"/>		<input type="checkbox"/>	
7. Check the battery electrolyte level and specific gravity if accessible. Adjust as necessary.	<input type="checkbox"/>		<input type="checkbox"/>		<input type="checkbox"/>		<input type="checkbox"/>		<input type="checkbox"/>	
8. Check the battery posts, cables, and charger for loose connections, corrosion, and proper operation. Correct as necessary.	<input type="checkbox"/>		<input type="checkbox"/>		<input type="checkbox"/>		<input type="checkbox"/>		<input type="checkbox"/>	
9. Check the unit wiring for loose connections, corrosion, and damage. Correct as necessary.	<input type="checkbox"/>		<input type="checkbox"/>		<input type="checkbox"/>		<input type="checkbox"/>		<input type="checkbox"/>	



## Standby Generator Sets Service Schedule



Maintenance Tasks	Level 1	Level 2		Level 3		Level 4		Level 5		
	Recom- mended to be done monthly/ 10 hrs.	Task Comp. (Date- Initials)	Required to be done 3 months/ Break-in 30 hrs.	Task Comp. (Date- Initials)	Required to be done Semi- annually/ 50 hrs.	Task Comp. (Date- Initials)	Required to be done Annually/ 100 hrs.	Task Comp. (Date- Initials)	Required to be done Bi- annually/ 250 hrs.	Task Comp. (Date- Initials)
10. Check the engine accessory drive belts and fan coupling device if equipped for correct tension, wear, weather cracking, and damage. Replace as necessary.			○				○		○	
11. Check the engine valve clearance/lash. Adjust as necessary.							○		○	
12. Visually inspect the unit looking for leaks, wear or damage, loose connections or components, and corrosion. Correct as necessary.							○		○	
13. Test the engine and transfer switch safety devices. Correct and/or adjust as necessary.	○		○		○		○		○	
14. Initiate an automatic start and transfer of the unit to site load and exercise it for at least 1 hour looking for leaks, loose connections or components, and abnormal operating conditions. Correct as necessary.							○		○	
15. Replace the engine accessory drive belts.									○	
16. Check gearbox oil level (if equipped).	○		○		○		○		○	
17. Change gearbox oil (if equipped).									○	



## Standby Generator Sets Service Schedule



Maintenance Tasks	Level 1	Task Comp. (Date-Initials)	Level 2	Task Comp. (Date-Initials)	Level 3	Task Comp. (Date-Initials)	Level 4	Task Comp. (Date-Initials)	Level 5	Task Comp. (Date-Initials)
	Recommended to be done monthly/ 10 hrs.		Required to be done 3 months/ Break-in 30 hrs.		Required to be done Semi-annually/ 50 hrs.		Required to be done Annually/ 100 hrs.		Required to be done Bi-annually/ 250 hrs.	
18. Start and exercise the unit at full rated load (use a load bank if the site load is not enough) for at least 2 hours looking for leaks, loose connections or components, and abnormal operating conditions. Correct as necessary.									●	
19. Perform an engine oil analysis (send a sample to a lab for results). Change the engine oil and filters if the analysis results indicate this is required.							●			
20. Change the engine oil.			●				●		●	
21. Replace the engine oil filter(s).			●				●		●	
22. Replace engine spark plugs. Clean and re-gap or replace as necessary.							●			
23. Replace the engine air filter(s).									●	
24. Perform a 5 minute no-load operational run of the unit looking for any post service problems.			●						●	
25. Return the unit to standby setup for operation when required.	●		●		●		●		●	





### TROUBLESHOOTING GUIDE

PROBLEM	CAUSE	CORRECTION
Engine won't crank.	<ol style="list-style-type: none"> <li>1. 15 amp fuse blown.</li> <li>2. Loose or corroded or defective battery cables.</li> <li>3. Defective starter contactor.</li> <li>4. Defective starter motor.</li> <li>5. Dead or Defective Battery.</li> <li>6. 5 amp fuse blown.</li> </ol>	<ol style="list-style-type: none"> <li>1. Replace fuse.</li> <li>2. Tighten, clean or replace battery cables as necessary.</li> <li>3. Replace contactor.*</li> <li>4. Replace starter motor.*</li> <li>5. Remove, change or replace battery.</li> <li>6. Replace fuse.*</li> </ol>
Engine cranks but won't start	<ol style="list-style-type: none"> <li>1. Out of fuel.</li> <li>2. Fuel solenoid (FS) is defective</li> <li>3. Open Wire #14A from Engine Control circuit board.</li> <li>4. Spark plugs defective.</li> <li>5. Door on tank not closed.</li> </ol>	<ol style="list-style-type: none"> <li>1. Replenish fuel.</li> <li>2. Replace solenoid.*</li> <li>3. Reconnect wire.</li> <li>4. Clean, regap or replace plugs.</li> <li>5. Close door on tank.</li> </ol>
Engine starts hard, runs rough.	<ol style="list-style-type: none"> <li>1. Flame arrestor (air cleaner) plugged or damaged.</li> <li>2. Plugged fuel line.</li> <li>3. Defective spark plugs.</li> <li>4. Fuel pressure incorrect.</li> </ol>	<ol style="list-style-type: none"> <li>1. Clean or replace as needed.</li> <li>2. Unclog fuel line.</li> <li>3. Clean, regap or replace plugs.</li> <li>4. Confirm fuel pressure to regulator is as recommended in SPECIFICATIONS.</li> </ol>
Engine starts then shuts down.	<ol style="list-style-type: none"> <li>1. Engine oil level is low.</li> <li>2. Engine is overheated.</li> <li>3. Defective Low Oil Pressure Switch</li> <li>4. Defective Coolant Temperature Switch</li> <li>5. Defective Control Module circuit board.</li> <li>6. Coolant Level is Low.</li> <li>7. Defective Low Coolant Level Switch</li> </ol>	<ol style="list-style-type: none"> <li>1. Check oil and add oil as needed.</li> <li>2. Check cooling system for leaks.</li> <li>3. Replace switch.*</li> <li>4. Replace switch.*</li> <li>5. Replace board.*</li> <li>6. Repair leak - Add coolant.</li> <li>7. Replace Switch.*</li> </ol>
AUTO/OFF/MANUAL Switch at OFF, engine continues to run	<ol style="list-style-type: none"> <li>1. Defective AUTO/OFF/MANUAL switch</li> <li>2. Open/disconnected wire #15A between AUTO/OFF/MANUAL switch and Control Module circuit board.</li> <li>3. Defective Control Module circuit board</li> </ol>	<ol style="list-style-type: none"> <li>1. Replace switch.*</li> <li>2. Reconnect/close wire.</li> <li>3. Replace board.*</li> </ol>
No AC output from generator.	<ol style="list-style-type: none"> <li>1. Check main line circuit breaker.</li> <li>2. Check circuit breaker &amp; fuses.</li> <li>3. Transfer switch set to NORMAL position</li> <li>4. Generator internal failure.</li> <li>5. Thermal circuit breaker open.</li> </ol>	<ol style="list-style-type: none"> <li>1. Reset to ON or CLOSED.</li> <li>2. Reset and replace, if necessary.</li> <li>3. Set to GENERATOR position.</li> <li>4. *</li> <li>5. Auto-reset - Wait 5 min. and attempt restart.</li> </ol>

**\*Contact the nearest Authorized Dealer for assistance.**





NOTES

**Standby Generator Sets**  
**Notes**

NOTES

A series of horizontal lines for taking notes.



# GROUP A

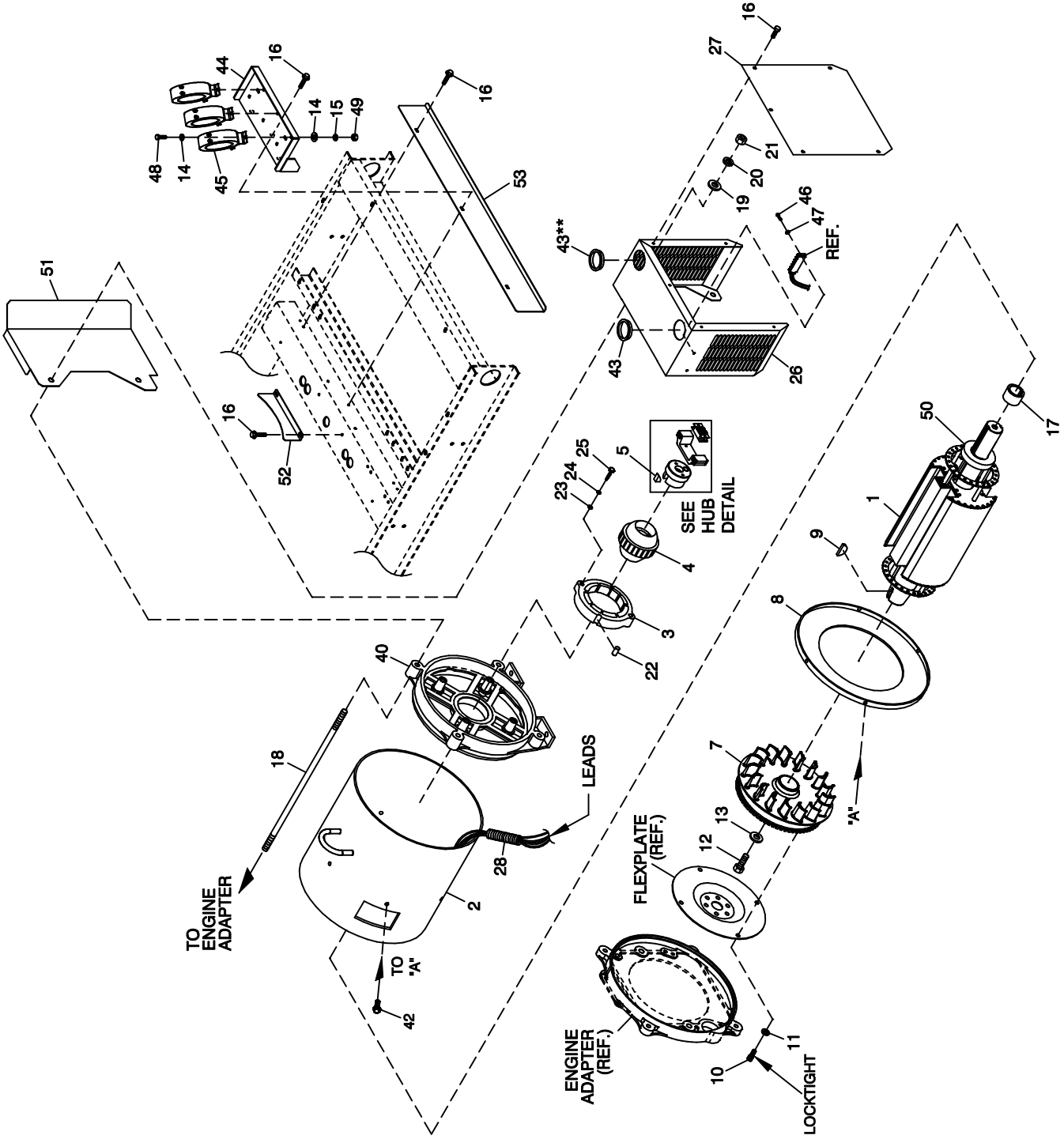

EXPLODED VIEW:  
 CPL ALTERNATOR BRSHLSS 80,100 & 150KW 2-POLE  
 DRAWING #: 0F2987

**EXPLODED VIEW: CPL ALTERNATOR BRUSHLESS 80, 100 & 150KW 2-POLE  
DRAWING #: 0F2987**

**GROUP A**

APPLICABLE TO:

ITEM	PART #	QTY.	DESCRIPTION	ITEM	PART #	QTY.	DESCRIPTION
1	0F9952	1	ASSY ROTOR 2390 80KB3 CPL	16	0C2454	11	SCREW THF M6-1 X 16 N WA ZJS
	0F3417	1	ASSY ROTOR 390 2P 100K BRSHLS	17	092950	1	COLLAR SLIP FIT 390 MM
	0F2984	1	ASSY ROTOR 390 2P 150K BRSHLS	18	04576100CF	4	STUD M14-2.0 X 760 G5 ZINC
2	0F9949	1	ASSY STATOR 80KW 1PH 2P BRSHLS	19	052646	4	WASHER FLAT M14
	0F3418	1	ASSY STATOR 390 2P 100K BRSHLS	20	043123	4	WASHER LOCK M14
	0F2985	1	ASSY STATOR 390 2P 150K BRSHLS UL	21	051779	4	NUT HEX M14-2.0 G8 YEL CHR
	0F9950	1	STATOR 2390 80 GB3 CPL	22	022392	2	PIN DOWEL 1/2 X 1-1/4
	0F9951	1	STATOR 2390 80 KB3 CPL	23	052259	2	WASHER FLAT M12
	0F6183	1	ASSY STR 390 100KW 2P 3PH 208V	24	051769	3	WASHER LOCK M12
	0F6187	1	ASSY STR 100KW 1PH 2P BRSHLS	25	0E7230	3	SCREW HHC M12-1.75 X 80 G10.9
	0F6184	1	ASSY STR 390 150KW 2P 3PH 208V	26	0F3033	1	SHIELD ALT EXCITER 390
	0F6212	1	ASSY STR 150KW 1PH 2P BRSHLS	0F9492	1	SHIELD ALT EXCITER 5.4/6.8 (1 PHASE)	
	0G2023	1	ASSY STR 390 150KW 2P 3PH 240V	27	0F2722	1	COVER EXCITER SHIELD
3	068405C	1	EXITER FIELD 2" LG SPD CONN	28	077043F	1	CONDUIT FLEX 1.25" ID
4	0F3013	1	ASSY EXCITER 2.0" STACK 2P	29	020151	1	CLAMP VINYL .312 X .203 Z
5	072878	1	KEY SQ 3/8 X 3-1/4 STEEL	30	023365	3	WASHER SHAKEPROOF INT #8
6	0C9708	REF	HYPOT TEST PROCEDURE (NOT SHOWN)	31	033133	1	SCREW HHM #8-32 X 3/8
7	0F3726B	1	ASSY FLYWHEEL CPL	32	033143	2	SCREW HHM #8-32 X 7/8
8	0F2689	1	RING PRESSURE 390 STATOR CAN	33	086032	2	LUG RT-ANG #10/10-12
9	023454	1	KEY WOODRUFF #E	34	090063	1	BRIDGE SUPPORT DIODE 15"
10	0F8408	4	SCREW HHC M10-1.50 X 16 G10.9	35	090064	1	CAP END ROTOR 390MM
11	046526	4	WASHER LOCK M10	36	090152	1	ASSY BRIDGE RECTIFIER
12	0A2601	1	SCREW HHC M16-2.0 X 45 G8.8	37	022661L	1	SLEEVE UL #0 .330 ID (3" LG)
13	0A2602	1	WASHER FLAT .688 ID X 3.25 OD	38	028739A	2	TIE WRAP UL 3.9" X .10" BLK
14	022473	8/12	WASHER FLAT 1/4-M6 ZINC	39	085662D	1	TIE WRAP UL 17.7 X .35 BLK HT
15	022097	4/6	WASHER LOCK M6-1/4	40	068113	1	CARRIER REAR BRG 15" (BRUSHLESS)
				41	068406	1	SCREW HHC M12-1.75 X 60 G10.9
				42	0F7272	6	SCREW 1/4-20 X 5/8" TAPTITE SS
				43	023484N	1	BUSHING SNAP SB-2.5-31
				023484N	2	BUSHING SNAP SB-2.5-31 (FOR 5.4/6.8 1 PHASE)	
				44	0F6819	1	MOUNT CT'S 5.4L 100KW
				45	REF.	2/3	TRANSFORMER
				46	0C2428	2	SCREW PHTT #6-32 X 1/2 ZYC
				47	022155	2	WASHER LOCK #6
				48	042568	4/6	SCREW HHC M6-1.0 X 20 G8.8
				49	049813	4/6	NUT HEX M6 X 1.0 G8 YEL CHR
				50 *	052624	1	BEARING BALL 6212 SEALED
				51	0F7030	1	SHROUD UPPER ALTERNATOR EXCITR
				52	0F7047	1	SHROUD CENTER ALTERNATR EXCITR
				53	0F7029	1	SHROUD LOWER ALTERNATOR EXCITR
				60	0F3834	1	ASSY SCROLL 390 X 60MM CPL
					KIT PARTS		I/N'S: 61 THRU 69
				61	0F3846B	2	SHROUD ALT SHEET METAL CPL 2P
				62	0F3892	2	SCREEN, 390 SAE ALT 60MM WIDE
				63	0A2496A	2	BRACKET SAE SCROLL TENSIONER
				64	056326	8.4 FT.	VINYL TRIM 1/8" GAP
				65	022097	6	WASHER, SPLIT 1/4"-M6
				66	022473	6	WASHER FLAT 1/4 ZINC
				67	045757	2	SCREW HHC M6-1.0 x 25 LONG
				68	047411	4	SCREW HHC M6-1.0 X 16 G8.8
				69	0A2110	12	SCREW SWAGE 1/4-20 X 1/2 Z/YC

\* ROTOR REPLACEMENT PARTS.

\*\* 1 PHASE UNITS REQUIRE SEPERATION OF LEADS.

QTY. REQ: 1 PHASE / 3 PHASE

# GROUP A

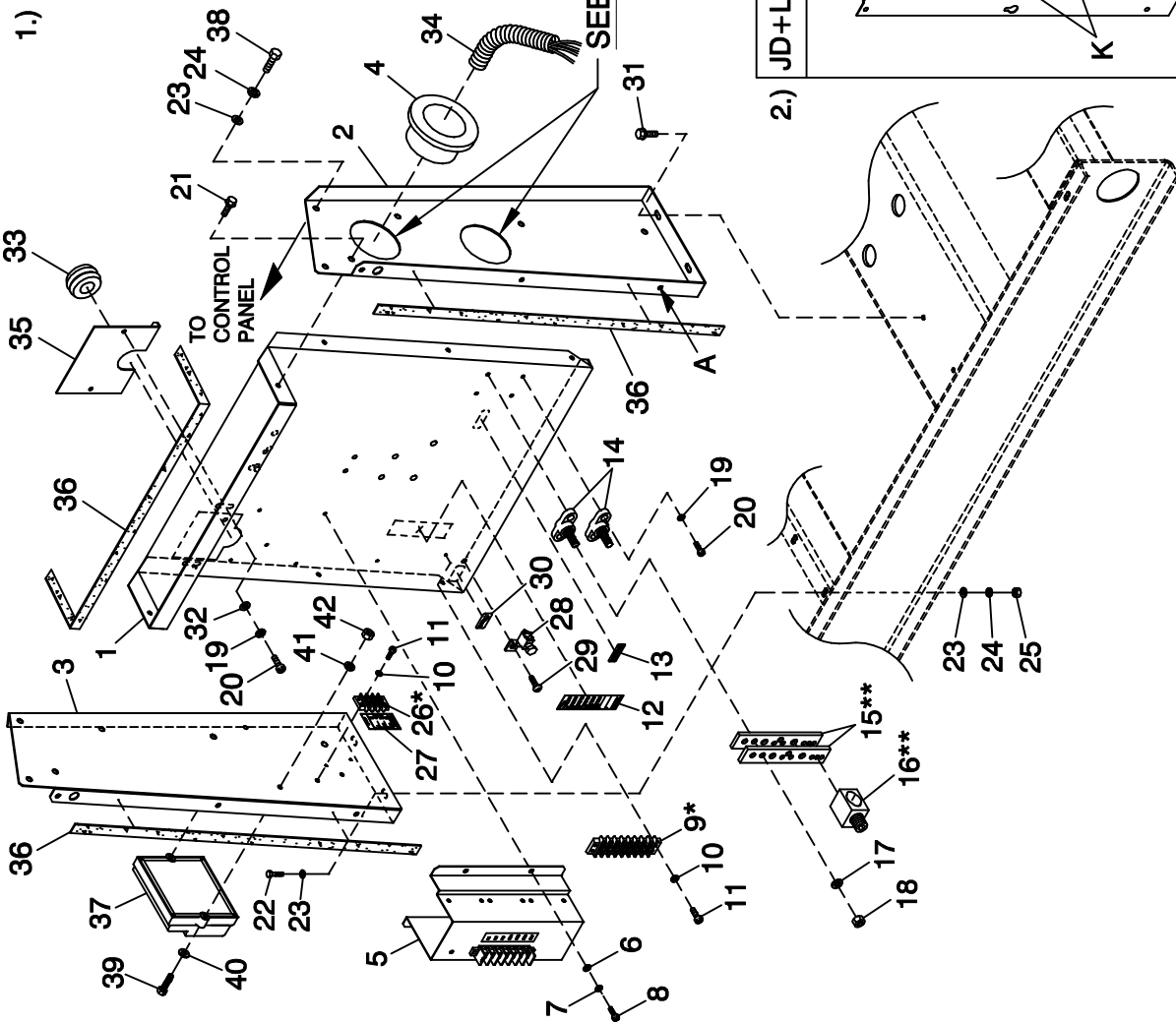
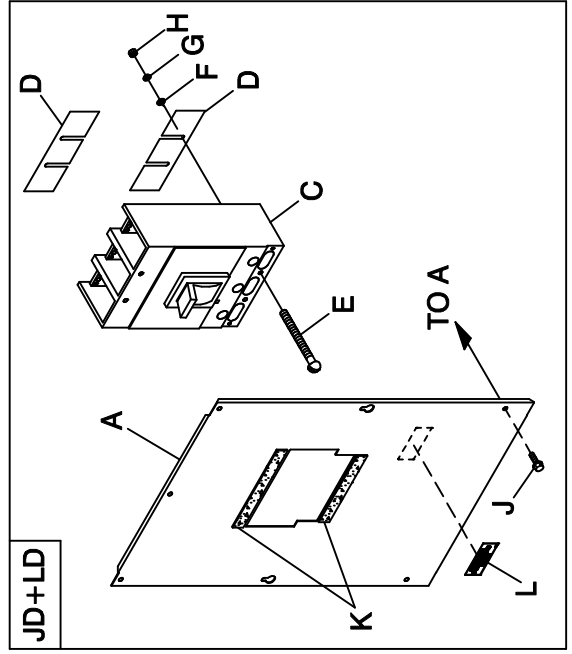
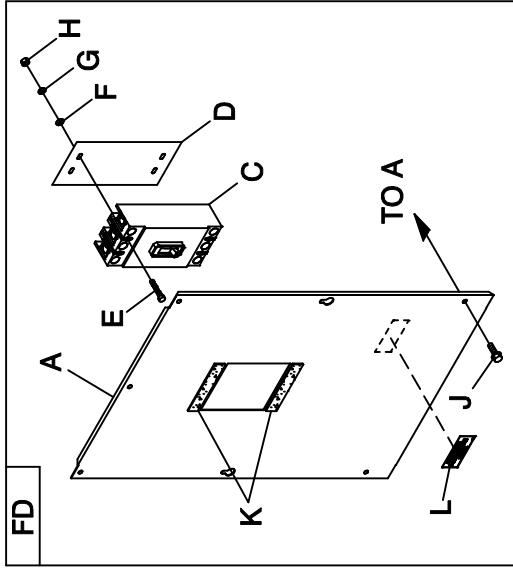

EXPLODED VIEW:  
 CPL C3 H CONTROL CB CONNECTION  
 DRAWING #: 0F3393D



EXPLODED VIEW: CPL C3 H CONTROL CB CONNECTION  
DRAWING #: 0F3393D

GROUP A

APPLICABLE TO:

ITEM	PART #	QTY.	DESCRIPTION
1	0F2885	1	PANEL CB CONN BOX
2	0F2883	1	STAND RH CONTROL
	0F9637 (4)	1	STAND RH CONTROL, TWO HOLE (FOR 5.4L 100KW & 4.6L 80KW 1PHASE)
3	0F3685	1	STAND LH CONTROL C5 GRBX
4	023484N	1	BUSHING SNAP SB-2.5-31
	023484N	2	BUSHING SNAP SB-2.5-31 (FOR 5.4L 100KW & 4.6L 80KW 1PHASE)
5	086961	1	INTERFACE 1PH 240V
	067617030A	-	INTERFACE 3PHS 416/480V
	067617030B	-	INTERFACE 3PHS 208/240V
6	043180	4	WASHER FLAT M4
7	022264	4	WASHER LOCK #8-M4
8	0C3990	4	SCREW PHTT M4-0.7 X 10 ZYC
(1) 9	057701	REF.	BLOCK TERM 20A 8 X 6 X 1100V
10	022155	2	WASHER LOCK #6
11	0C2428	2	SCREW PHTT #6-32 X 1/2 ZYC
12	0F3618	1	DECAL CPL CUST CONN H CTRL
13	0A9457	1	DECAL NEUTRAL
14	057073	2	JUNCTION BLOCK 3/8-16
(2) 15	0D5466	REF.	BUS BAR NEUTRAL BLOCK 390
(2) 16	0A7822	REF.	LUG SLDLSS 600/250-1/0 X 1/4-28
17	022237	4	WASHER LOCK 3/8
18	022241	4	NUT HEX 3/8-16 STEEL
19	049226	6	WASHER LOCK M5
20	0C2266	6	SCREW PHTT M5-0.8 X 16 ZYC
21	0C2454	10	SCREW THF M6-1 X 16 N WA Z/JJS
22	042568	4	SCREW HHC M6-1.0 X 20 G8.8
23	022473	12	WASHER FLAT 1/4-M6 ZINC
24	022097	8	WASHER LOCK M6-1/4
25	049813	4	NUT HEX M6 X 1.0 G8 YEL CHR
(1) 26	0D4698	1	BLOCK TERM 20A 6 X 3 X 1100V
27	0F4464	1	DECAL CUST CONN 120V UTILITY
28	025433	1	LUG SLDLSS #6-14 X 13/64 CU
29	024469	1	SCREW HHTT #10-32 X 3/8 CZ
30	067210A	1	DECAL GROUND LUG
31	0D6029	4	SCREW HHTT M6-1.0 X 16 ZYC
32	051713	2	WASHER FLAT M5
33	081008	1	GROMMET 1.25 X .25 X .75
34	077043J	3	CONDUIT FLEX 2.0" ID
	077043J	4	CONDUIT FLEX 2.0" ID (FOR 5.4L 100KW & 4.6L 80KW 1 PHASE)
35	0F6156	1	PLATE WIRE SNGL GALV
36	029289	1	TAPE ELEC 1/2 FOAM (AS REQ'D)
(3) 37	0F8656	REF	ASSY PCB 4.6L IGNITION MODULE
	0F3113	REF	ASSY PCB HSB CTRL IGN MODULE (ALL OTHER APPLICATIONS EXCEPT 4.6L G3)
38	047411	4	SCREW HHC M6-1.0 X 16 G8.8
39	036943	2	SCREW PPHM #10/32 X 2
40	023897	2	WASHER FLAT #10 ZINC
41	022152	2	WASHER LOCK #10
42	022158	2	NUT HEX #10-32 STEEL

ITEM	PART #	QTY.	DESCRIPTION
1.)			UL CIRCUIT BREAKER (FD)
A	0F2887	1	COVER FD FRM CB
C	0D5572	-	CB 0150A 3P 600V S FD6 LL
	0D5573	-	CB 0175A 3P 600V S FD6 LL
	0D5575	-	CB 0225A 3P 600V S FD6 LL
	0D5576	-	CB 0250A 3P 600V S FD6 LL
D	0F0199	1	INSULATOR CB FD FRAME 30MIL
E	065960	4	SCREW SHC 1/4-20 X 4 G8.8 NZ
F	022473	4	WASHER FLAT 1/4-M6 ZINC
G	022097	4	WASHER LOCK M6-1/4
H	022127	4	NUT HEX 1/4-20 STEEL
J	0C2454	4	SCREW THF M6-1 X 16 N WA Z/JJS
K	029289	1	TAPE ELEC 1/2 FOAM (AS REQ'D)
L	0F1733	1	DECAL CUSTOMER CONNECT INSIDE
2.)			UL CIRCUIT BREAKER (JD+LD)
A	0F2721	1	COVER CIR BRKR JD/LD
C	0D5577	-	CB 0300A 3P 600V S JD6 LL
	0D5578	-	CB 0350A 3P 600V S JD6 LL
	0D5579	-	CB 0400A 3P 600V S JD6 LL
	0D5581	-	CB 0600A 3P 600V S LD6
	0D5585	-	CB 0450A 3P 600V S LD6 LL
D	0F2353	2	INSULATOR CIRCUIT BR. JD/LD
E	022770	4	SCREW RHM 1/4-20 X 3
F	022473	4	WASHER FLAT 1/4-M6 ZINC
G	022097	4	WASHER LOCK M6-1/4
H	022127	4	NUT HEX 1/4-20 STEEL
J	0C2454	7	SCREW THF M6-1 X 16 N WA Z/JJS
K	029289	1	TAPE ELEC 1/2 FOAM (AS REQ'D)
L	0F1733	1	DECAL CUSTOMER CONNECT INSIDE

(1) ITEM INCLUDED WITH HARNESS.

(2) ITEM INCLUDED WITH 0D5464B.

(3) ITEM IS PART OF 9R.

(4) ROUTE ONE SET (11, 22, 33, 44) THROUGH ONE HOLE; AND ROUTE THE SECOND SET (11, 22, 33, 44) THROUGH THE OTHER HOLE.

GROUP A

3.) 225AF

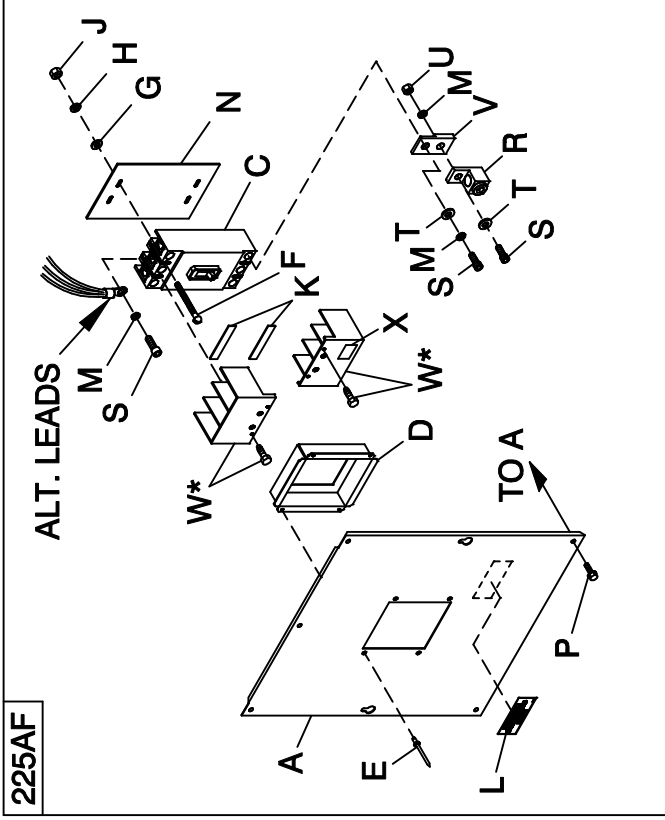

4.) 400AF

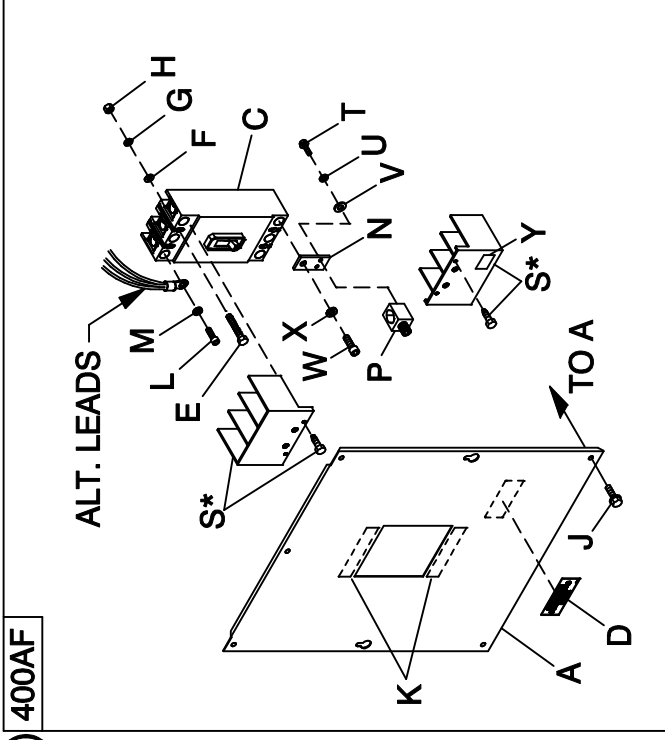

5.) 800AF

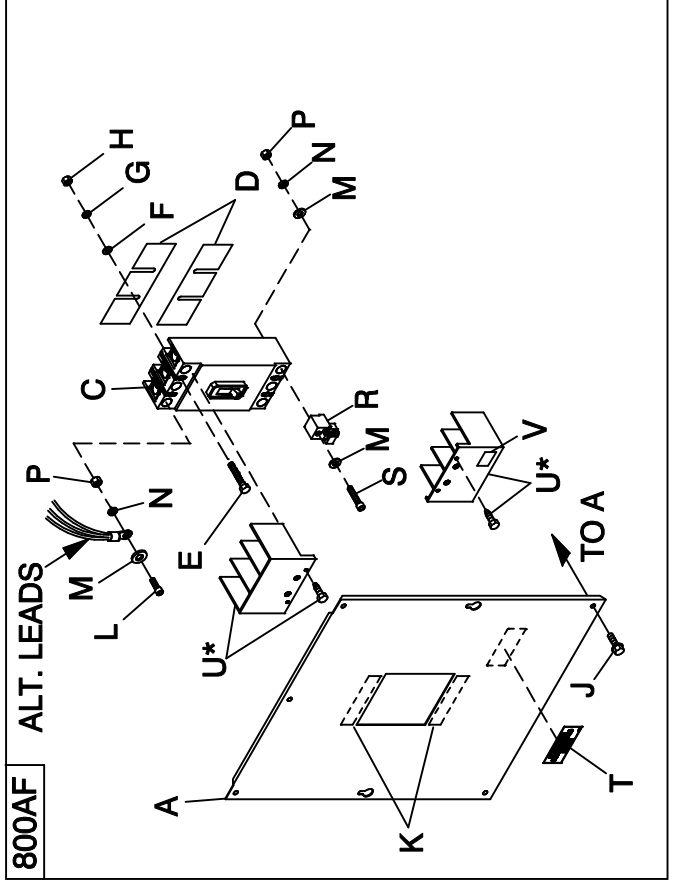

6.) 0D5464B

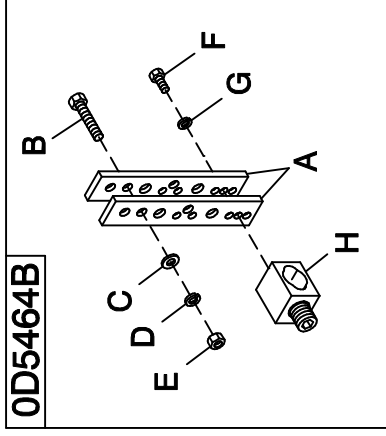

EXPLODED VIEW: CPL C3 H CONTROL CB CONNECTION  
 DRAWING #: 0F3393D

GROUP A

APPLICABLE TO:

ITEM	PART #	QTY.	DESCRIPTION
3.)			UL CIRCUIT BREAKER (225AF)
A	0F4173	1	COVER CB C5 225AF
C	0F4165\$	REF	CIRCUIT BREAKERS 200A FRAME
D	0F4186	1	COVER CB DISH 225AF
E	036261	4	RIVET POP .125 X .275 SS
F	053640	4	SCREW RHM #8-32 X 3-1/4
G	038150	4	WASHER FLAT #8 ZINC
H	022264	4	WASHER LOCK #8-M4
J	022471	4	NUT HEX #8-32 STEEL
K	029289	2	TAPE ELEC 1/2 FOAM
L	0F1733	1	DECAL CUSTOMER CONNECT INSIDE
M	022129	9	WASHER LOCK M8-5/16
N	0F8432	1	INSULATOR CB 225AF
P	0C2454	7	SCREW THF M6-1 X 16 N WA Z/JS
R	0F8451	3	LUG SLDLSS 300 MCM-6 AL/CU
S	049897	9	SCREW SHC M8-1.25 X 20 G8
T	022145	6	WASHER FLAT 5/16-M8 ZINC
U	045771	3	NUT HEX M8-1.25 G8 CLEAR ZINC
V	0F8843	3	BUS BAR 200A LUG ADAPTOR
(1) W	W/CB	2	TERMINAL COVER CB
X	0G3259	1	DECAL TERMINAL SHOCK HZD BI
4.)			UL CIRCUIT BREAKER (400AF)
A	0F4175	1	COVER CB C5 400AF
C	0F4166\$	REF	CIRCUIT BREAKERS 400A FRAME
D	0F1733	1	DECAL CUSTOMER CONNECT INSIDE
E	042419	4	SCREW RHM 10-32 X 4
F	023897	4	WASHER FLAT #10 ZINC
G	022152	4	WASHER LOCK #10
H	022158	4	NUT HEX #10-32 STEEL
J	0C2454	7	SCREW THF M6-1 X 16 N WA Z/JS
K	029289	1	TAPE ELEC 1/2 FOAM
(2) L	052647	2/3	SCREW SHC M10-1.5 X 25 G12.9
(2) M	046526	2/3	WASHER LOCK M10
N	W/CB	3	BUS BAR CB ADAPTER 225-400 A
P	0A7822	3	LUG SLDLSS 600/250-1/0 X 1/4-28
R	022131	3	WASHER FLAT 3/8-M10 ZINC
(1) S	W/CB	2	TERM COVER CB
T	023334	6	SCREW HHC 1/4-28 X 1/2 G5
U	022097	6	WASHER LOCK M6-1/4
V	022473	6	WASHER FLAT 1/4-M6 ZINC
(2) W	W/CB	2/3	SCREW SHC M10-1.5 X 25 G12.9
(2) X	W/CB	2/3	WASHER LOCK M10
Y	0G3259	1	DECAL TERMINAL SHOCK HZD BI

ITEM	PART #	QTY.	DESCRIPTION
5.)			UL CIRCUIT BREAKER (800AF)
A	0F4176	1	COVER CB C5 800AF
C	0F4167\$	REF	CIRCUIT BREAKERS 800A FRAME
D	0F8433	2	INSULATOR CB 800AF
E	024196	4	SCREW RHM 1/4-20 X 3-1/2
F	022473	4	WASHER FLAT 1/4-M6 ZINC
G	022097	4	WASHER LOCK M6-1/4
H	022127	4	NUT HEX 1/4-20 STEEL
J	0C2454	7	SCREW THF M6-1X16 N WA Z/JS
K	029289	2	TAPE ELEC 1/2 FOAM
L	060619	3	SCREW SHC M10-1.50 X 40 G12.9
M	022131	9	WASHER FLAT 3/8-M10 ZINC
N	022237	6	WASHER LOCK 3/8
P	045772	6	NUT HEX M10-1.5 G8 YEL CHR
R	0F8452	3	LUG SLDLSS 500-750 X 2 MCM AL/CU
S	097950	3	SCREW SHC M10-1.25 X 70 G8.8
T	0F1733	1	DECAL CUSTOMER CONNECT INSIDE
(1) U	W/CB	2	TERM COVER VITZROTECH 400AF CB
V	0G3259	1	DECAL TERMINAL SHOCK HZD BI
6.)			NEUTRAL BLOCK 390 / 200-400A
A	0D5466	2	BUS BAR NEUTRAL BLOCK 390
B	039287	1	SCREW HHC M8-1.25 X 45 G8.8 FT
C	022145	1	WASHER FLAT 5/16-M8 ZINC
D	022129	1	WASHER LOCK M8-5/16
E	045771	1	NUT HEX M8-1.25 G8 YEL CHR
F	045335	2	SCREW HHC 1/4-28 X 3/4 G5
G	022097	2	WASHER LOCK M6-1/4
H	0A7822	1	LUG SLDLSS 600/250-1/0X1/4-28

(1) HARDWARE FOR MTG. CB TERMINAL COVERS IS SUPPLIED WITH CIRCUIT BREAKERS.

(2) 2/3 QTY. 2POLE & 3 POLE CB.

# GROUP C

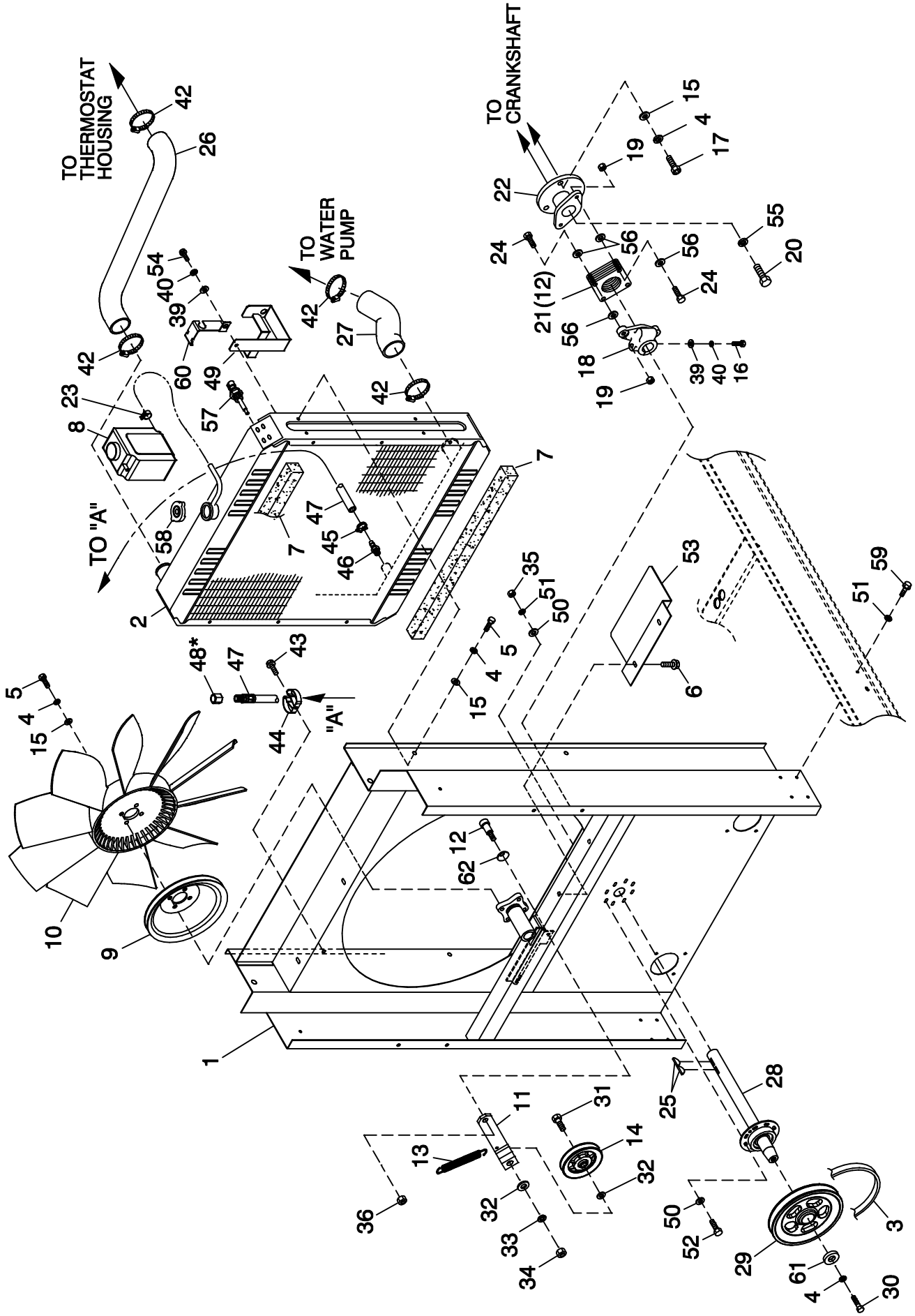

EXPLODED VIEW:  
COOLING SYSTEM & FAN DRIVE  
DRAWING #: 0F2703

EXPLODED VIEW: COOLING SYTEM & FAN DRIVE  
DRAWING #: 0F2703

GROUP C

APPLICABLE TO:

ITEM	PART #	QTY.	DESCRIPTION
1	0F2687	1	WELDMENT RADIATOR SUPPORT150
2	0F2611	1	RADIATOR 680 X 680 X 70 CPL
3	0F5254	1	V-BELT 31/64" X 62-3/8"
	0F5253	1	V-BELT 31/64" X 61-3/8" (5.4L 100KW ONLY)
	0F7077	1	V-BELT 1/2" X 63-3/8" (6.8L 100 130KW)
4	046526	12	WASHER LOCK M10
5	051756	8	SCREW HHC M10-1.5 X 20 G8.8
6	0C2454	2	SCREW THF M6-1 X 16 N WA ZJJS
7	052250	2	TAPE FOAM 1 X 1 (26.75" LG)
8	076749	1	TANK COOLANT RECOVERY
9	0F2573	1	PULLEY FAN V-GROOVE 9"
10	0F2610	1	FAN 26" LH ROTATION
11	0G51580ST03	1	TENSIONER ARM, PULLER SYSTEM
12	0G2990	1	SHOULDER BOLT 3/8 X 1/2"
13	0F2862	1	SPRING TENSION CPL
14	0F2560	1	PULLEY V-BELT 4" FLANGED
15	022131	15	WASHER FLAT 3/8-M10 ZINC
16	039414	1	SCREW HHC M8-1.25 X 35 G8.8
17	052625	3	SCREW SHC M10-1.5 X 35 G12.9
18	0F2561	1	HUB FLEX PLATE
19	0C8165	5	NUT HEX LOCK 5/16-24 NY INS
20	0D6795	1	SCREW HHC M12-1.5 X 60 G8.8
21	0C7043	12	DISK FLEX
22	0E8909	1	COUPLING HUB FLEX (MACH)
23	048031C	1	CLAMP HOSE BAND 1/4
24	0C8146	4	SCREW HHC 5/16-24 X 1.124
25	082774	2	KEY WOODRUFF 4 X 19D
26	0F2686	1	HOSE RADIATOR UPPER CPL
27	0F5463	1	HOSE LOWER RAD CPL C5 6.8L
28	0F8695	1	ASSY BRG/SHAFT CPL FANDRIVE
29	0F4028	1	PULLEY 6.5" DIA MACHINED (6.8L 100KW)
	0F4030	1	PULLEY 6" DIA MACHINED (6.8L 130KW)
	0F4032	1	PULLEY 5.5" DIA MACHINED (5.4L 80KW & 6.8L 150KW)
	0F4496	1	PULLEY 4.5" DIA MACHINED (5.4L 100KW)
30	042911	1	SCREW HHC M10-1.5 X 30 G8.8
31	0F2872	1	SCREW HHC 1/2-13 X 2" G8
32	022304	2	WASHER FLAT 1/2 ZINC
33	022195	1	WASHER LOCK 1/2
34	022196	1	NUT HEX 1/2-13 STEEL
35	049813	8	NUT HEX M6 X 1.0 G8 YEL CHR
36	070015	1	NUT HEX LOCK 5/16-18 NY INS SS
39	022145	1	WASHER FLAT 5/16-M8 ZINC
40	022129	1	WASHER LOCK M8-5/16
42	035685	4	CLAMP HOSE #28 1.32-2.25
43	045764	1	SCREW HHTT M4-0.7 X 8 BP
44	065852	1	SPRING CLIP HOLDER .37-.62
45	0C7649	1	CLAMP HOSE .38-.87
46	055596	1	BARBED STR 3/8 NPT X 3/8
47	069860E	1	HOSE DRAIN ASSY 28"
48*	069811	REF	CAP HEX 1/4 NPT BRASS
49	080713	1	BRACKET COOLANT TANK
50	022473	16	WASHER FLAT 1/4-M6 ZINC
51	022097	16	WASHER LOCK M6-1/4
52	042568	8	SCREW HHC M6-1.0 X 20 G8.8
53	0F5050	1	SHIELD RADIATOR C5
54	039253	1	SCREW HHC M8-1.25 X 20 G8.8
55	051769	1	WASHER LOCK M12
56	0C8145	8	WASHER FLEX (THIN)
57	0E2507	1	PROBE, COOLANT LEVEL 3/8 NPTF
58	090283	1	CAP RADIATOR 13 PSI
59	0C8566	8	SCREW HHFC M6-1.0 X 20 G8.8
60	0F2776A	1	BRACKET, SIGNAL CONDITIONER
61	052644	1	SPACER .5 X 1.5 X .25 STL/ZINC
62	0G4376	1	WASHER BELLEVILLE .75X.38X.028

\* ITEM 48 IS INCLUDED WITH 47.

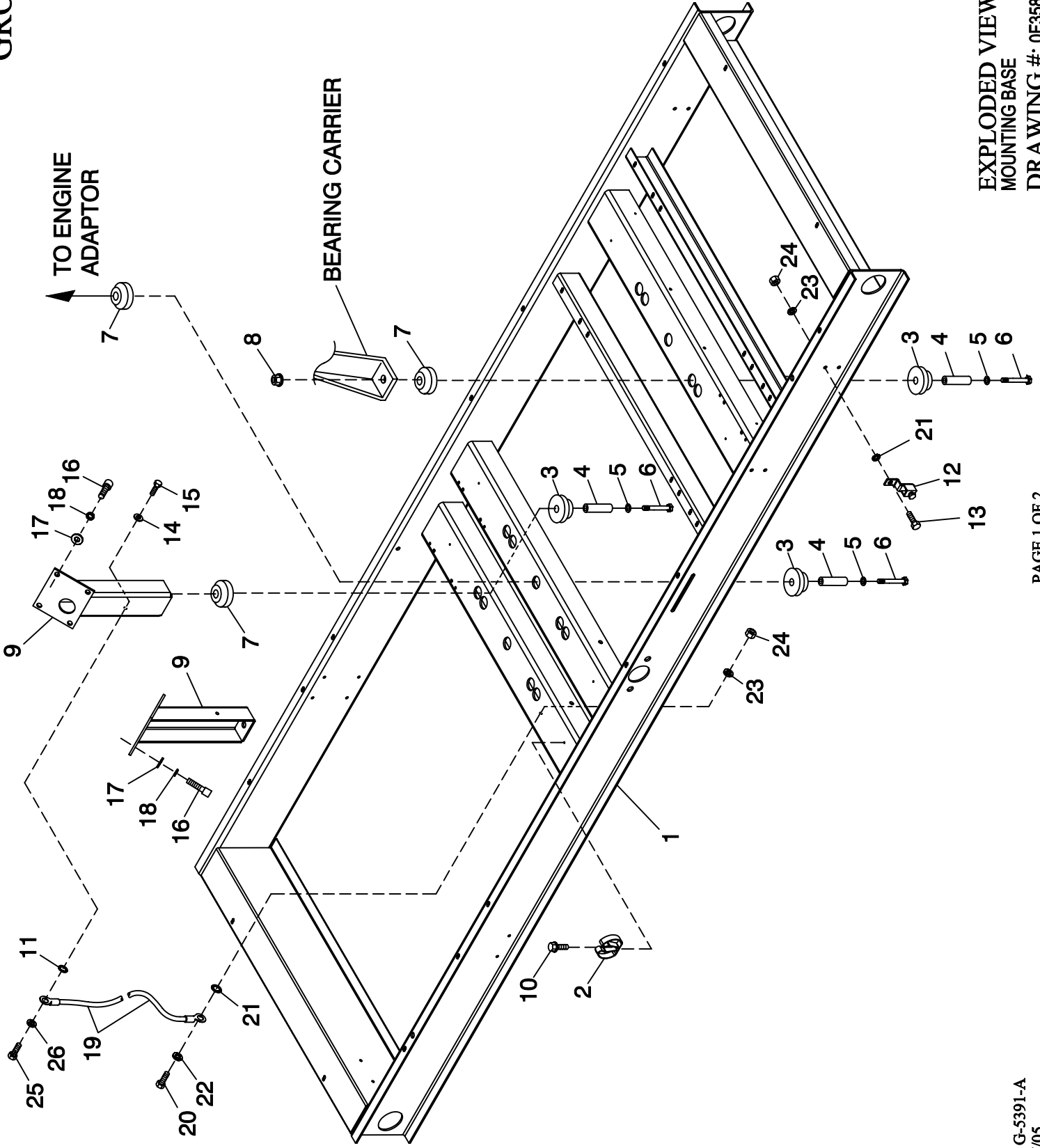

EXPLODED VIEW:  
MOUNTING BASE  
DRAWING #: 0F3589

**EXPLODED VIEW: MOUNTING BASE****DRAWING #: 0F3589****GROUP C****APPLICABLE TO: 5.4L SP 100KW**

<b>ITEM</b>	<b>PART #</b>	<b>QTY.</b>	<b>DESCRIPTION</b>
1	0F3099	1	MTG BASE CP 5.4L 100KW DD
2	065852	1	SPRING CLIP HOLDER .37-.62
3	052252	5	DAMPENER VIBRATION
4	052257	5	SPACER .49 X .62 X 1.87 PWDR/ZINC
5	052259	5	WASHER FLAT M12
6	055597	5	SCREW HHC M12-1.75 X 85 G8.8
7	052251A	5	DAMPENER VIBRATION 50 WHITE
8	052860	4	NUT LOCKING M12-1.75
9	0F2895	2	SUPPORT ENG 5.4L LH/RH 6.8L RH
10	045764	1	SCREW HHTT M4-0.7 X 8 BP
11	022447	1	WASHER SHAKEPROOF INT 1/4
12	061383	1	LUG SOLDERLESS 3/0-#4 X 13/32 CU
13	043107	1	SCREW HHC M8-1.25 X 25 G8.8
14	022473	1	WASHER FLAT 1/4-M6 ZINC
15	049813	1	NUT HEX M6 X 1.0 G8 YEL CHR
16	057192	8	SCREW SHC M10-1.5 X 30 G12.9
17	022131	8	WASHER FLAT 3/8-M10 ZINC
18	046526	8	WASHER LOCK M10
19	0536210360	1	WIRE ASSEM #4GA GRD
20	042909	1	SCREW HHC M8-1.25 X 30 G8.8
21	022261	2	WASHER SHAKEPROOF INT 3/8
22	022129	1	WASHER LOCK M8-5/16
23	022145	2	WASHER FLAT 5/16-M8 ZINC
24	045771	2	NUT HEX M8-1.25 G8 YEL CHR
25	038750	1	SCREW HHC M6-1.0 X 30 G8.8
26	022097	1	WASHER LOCK M6-1/4

# GROUP C

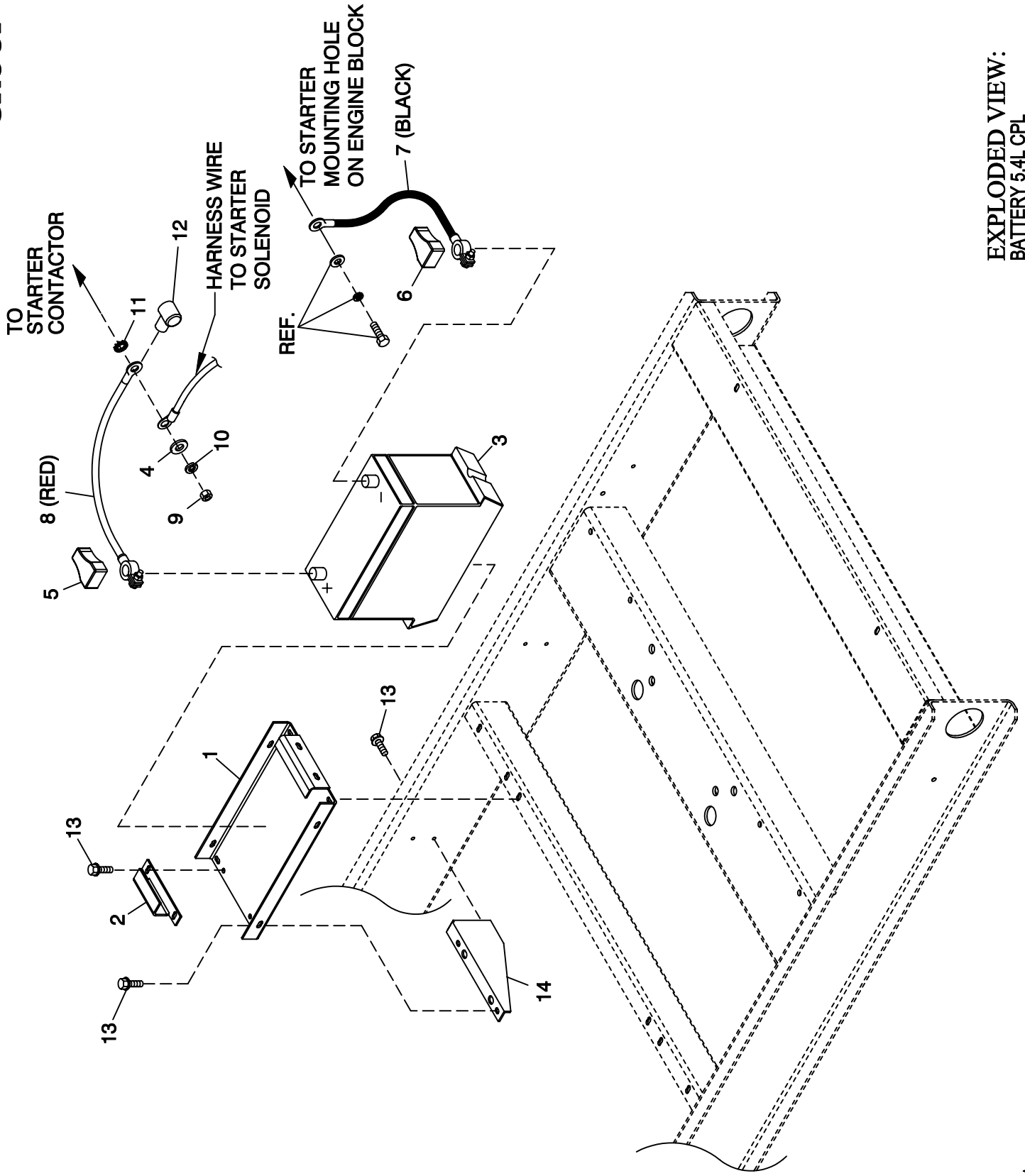

EXPLODED VIEW:  
BATTERY 5.4L CPL  
DRAWING #: 0F3675



EXPLODED VIEW: BATTERY 5.4L CPL

DRAWING #: 0F3675

GROUP C

APPLICABLE TO:

ITEM	PART #	QTY.	DESCRIPTION
1	0F3408	1	TRAY BATTERY
2	0F3411	1	STRAP BATTERY RETAINMENT
3	058208	1	BATT 12VDC 24F 625
4	022131	1	WASHER FLAT 3/8-M10 ZINC
5	050331A	1	BATT POST COVER RED +
6	050331	1	BATT POST COVER BLK -
7	038805U	1	CABLE BATT BLK #1 X 18.00
8	038804U	1	CABLE BATT RED #1 X 28.00
9	045771	1	NUT HEX M8-1.25 G8 YEL CHR
10	022129	1	WASHER LOCK M8-5/16
11	027482	1	WASHER SHAKEPROOF EXT 5/16 STL
12	075763	1	BOOT BATTERY CABLE
13	0C2454	8	SCREW THF M6-1X16 N WA Z/JS
14	0F3409	1	SUPPORT BATTERY TRAY

GROUP D

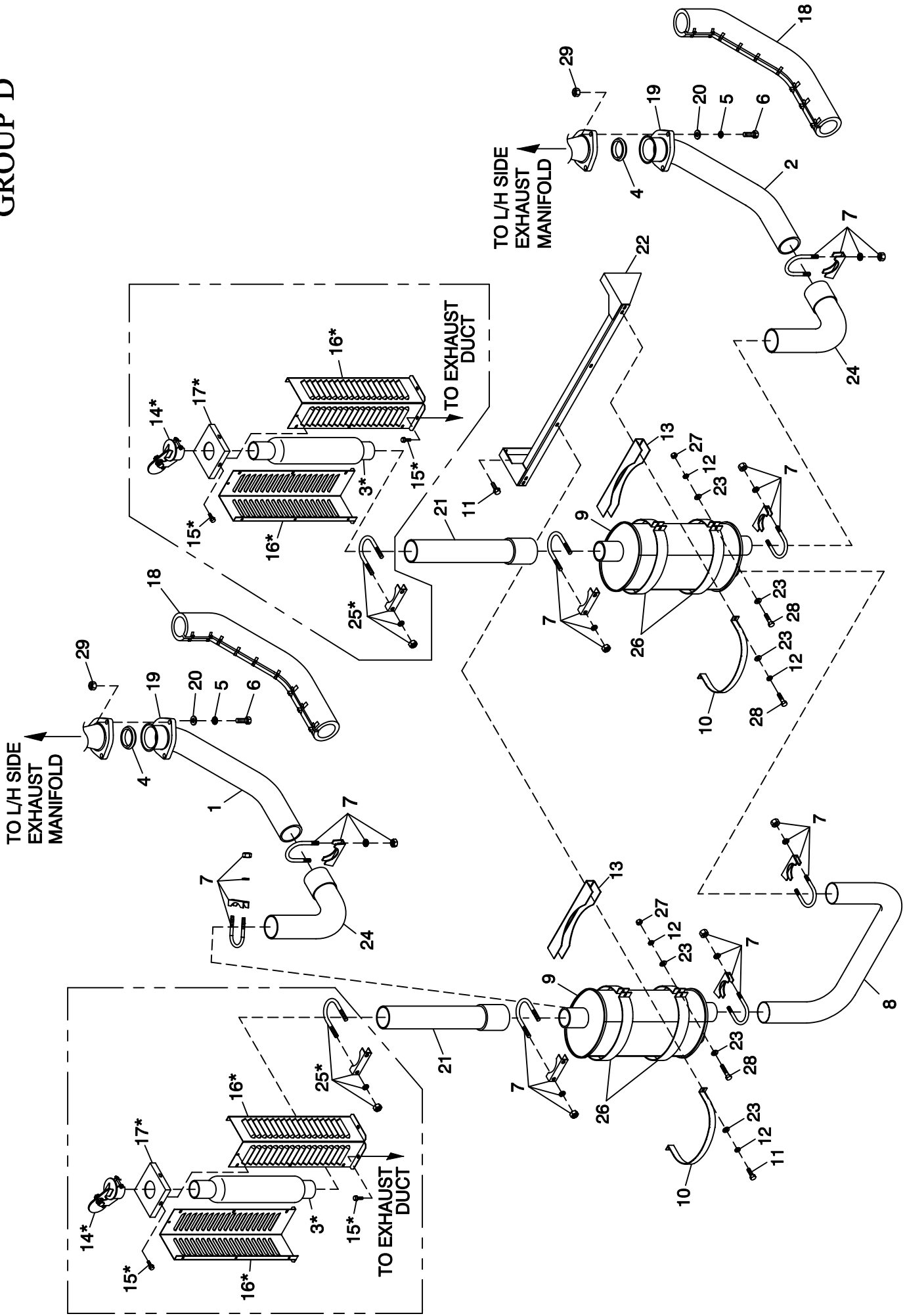

EXPLODED VIEW:  
MUFFLER 5.4L/6.8L CPL EXHAUST C5  
DRAWING #: 0F2969

**EXPLODED VIEW: MUFFLER 5.4L/6.8L CPL EXHAUST C5**  
**DRAWING #: 0F2969**

**GROUP D**

APPLICABLE TO:

<b>ITEM</b>	<b>PART #</b>	<b>QTY.</b>	<b>DESCRIPTION</b>
1	0F2807C	1	PIPE EXH MAN R/H 6.8L G/B CPL (6.8L C5)
	0F2807E	1	PIPE EXH MAN R/H 5.4L G/B & 2P (5.4L C5)
	0F9207	1	PIPE EXH MANIFOLD 4.6L RH
2	0F2807B	1	PIPE EXH MAN L/H 6.8L G/B CPL (6.8L C5)
	0F2807D	1	PIPE EXH MAN L/H 5.4L G/B & 2P (5.4L C5)
	0F9208	1	PIPE EXH MANIFOLD 4.6L LH
(1) 3	0F4505	REF	GLASS PACK 23.5" LG 2.5" IN/OUT
4	0A6765	2	RING GASKET 2.5 DIA
5	0F4710	6	WASHER LOCK M10 SS
6	0F7200	6	SCREW HHC M10-1.5 X 50 SS FTH
7	080762	8	BOLT U 3/8-16 X 2.62
8	0F2809	1	PIPE EXHAUST CROSSOVER
9	0F2981A	2	MFLR 7" X 9" X 25" (2) 2.5" IN/2.5" OUT
10	0F2962	2	MUFFLER STRAP
11	0C2454	4	SCREW THF M6-1 X 16 N WA Z/JS
12	022097	8	WASHER LOCK M6-1/4
13	0F2830	2	MUFFLER BRACKET STIFFENER
(1) 14	0F4462	REF	RAIN CAP ALUM FOR 2-1/2" PIPE
(1) 15	0C2454	REF	SCREW THF M6-1 X 16 N WA Z/JS
(1) 16	0F4367	REF	HEAT SHIELD EXHAUST STACK
(1) 17	0F4368	REF	CAP HEAT SHIELD EXHAUST STACK
18	0F2773C	2	EXHAUST BLANKET 900MM LONG (6.8L C5)
	0F2773D	2	EXHAUST BLANKET 850MM LONG (5.4L C5)
19	0D3159	2	FLANGE EXHAUST
20	088775	6	WASHER FLAT 3/8 SS
21	0F2808	2	EXHUAUST OUTLET PIPE CPL
22	0F5447	1	BRKT MUFFLER
23	022473	12	WASHER FLAT 1/4-M6 ZINC
24	0F6214	2	PIPE ELBOW EXHAUST MUFFLER
(1) 25	080762	REF	BOLT U 3/8-16 X 2.62
26	0F6803	4	MUFFLER STRAP UPPER/LOWER
27	049813	4	NUT HEX M6 X 1.0 G8 YEL CHR
28	049721	8	SCREW HHC M6-1.0 X 35 G8.8 BLK
29	088510	6	NUT HEX M10-1.5 SS

(1) PARTS INCLUDED IN 0F6332 KIT (TAN) OR 0F6332B KIT (TELECOM GRAY) GLASS PACK SHIP LOOSE.

# GROUP D

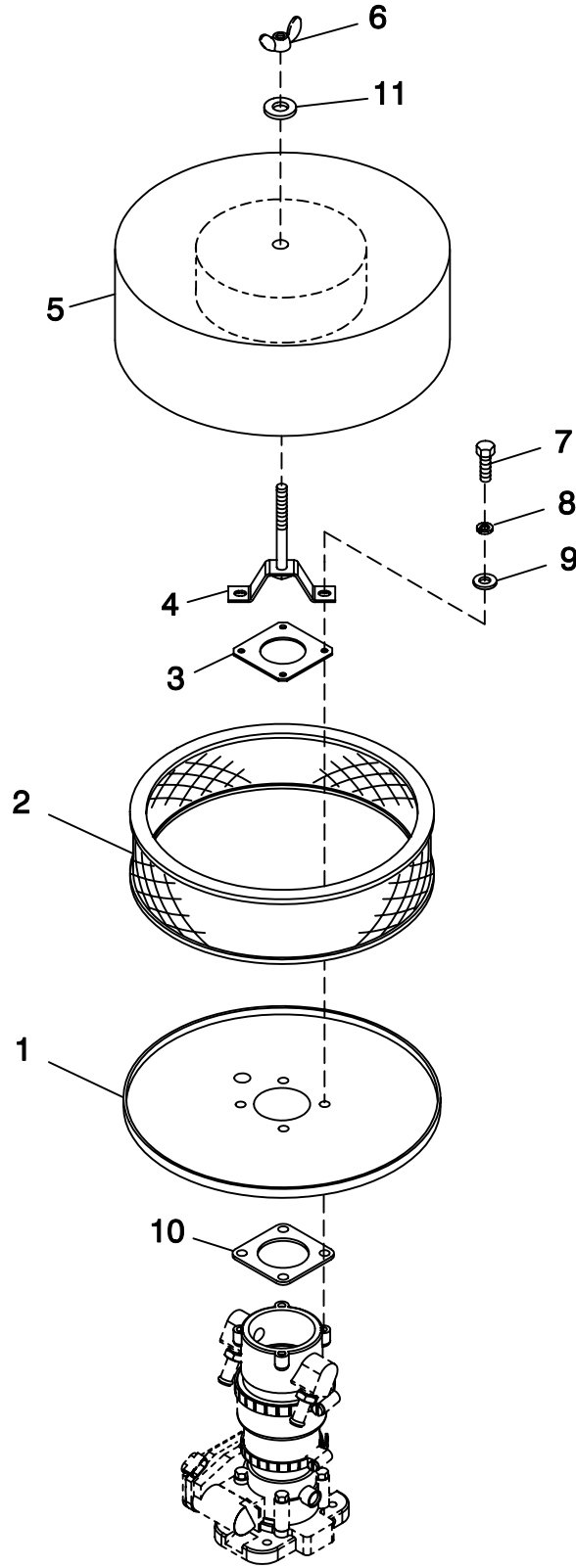

**EXPLODED VIEW: AIR CLEANER 5.4L/6.8L FORD**

**DRAWING #: 0F3569**

**GROUP D**

**APPLICABLE TO:**

<b>ITEM</b>	<b>PART #</b>	<b>QTY.</b>	<b>DESCRIPTION</b>
1	0D2513D	1	AIR CLNR BTM PLT W/CPLR 8.1L
2	0F5419	1	ELEMENT AIR FILTER
3	0F4268	1	TOP PLATE VENTURI
4	0F4270A	1	HOLD DOWN AIR CLEANER PLATED
5	0F6977	1	PLATE AIR CLEAN TOP 5.4L/6.8L
6	037561	1	NUT WING 1/4-20 NYLK
7	047411	4	SCREW HHC M6-1.0 X 16 G8.8
8	022097	4	WASHER LOCK M6-1/4
9	049811	4	WASHER FLAT M6
10	0F4269	1	GASKET MIXER BODY
11	022473	1	WASHER FLAT 1/4-M6 ZINC

# GROUP D

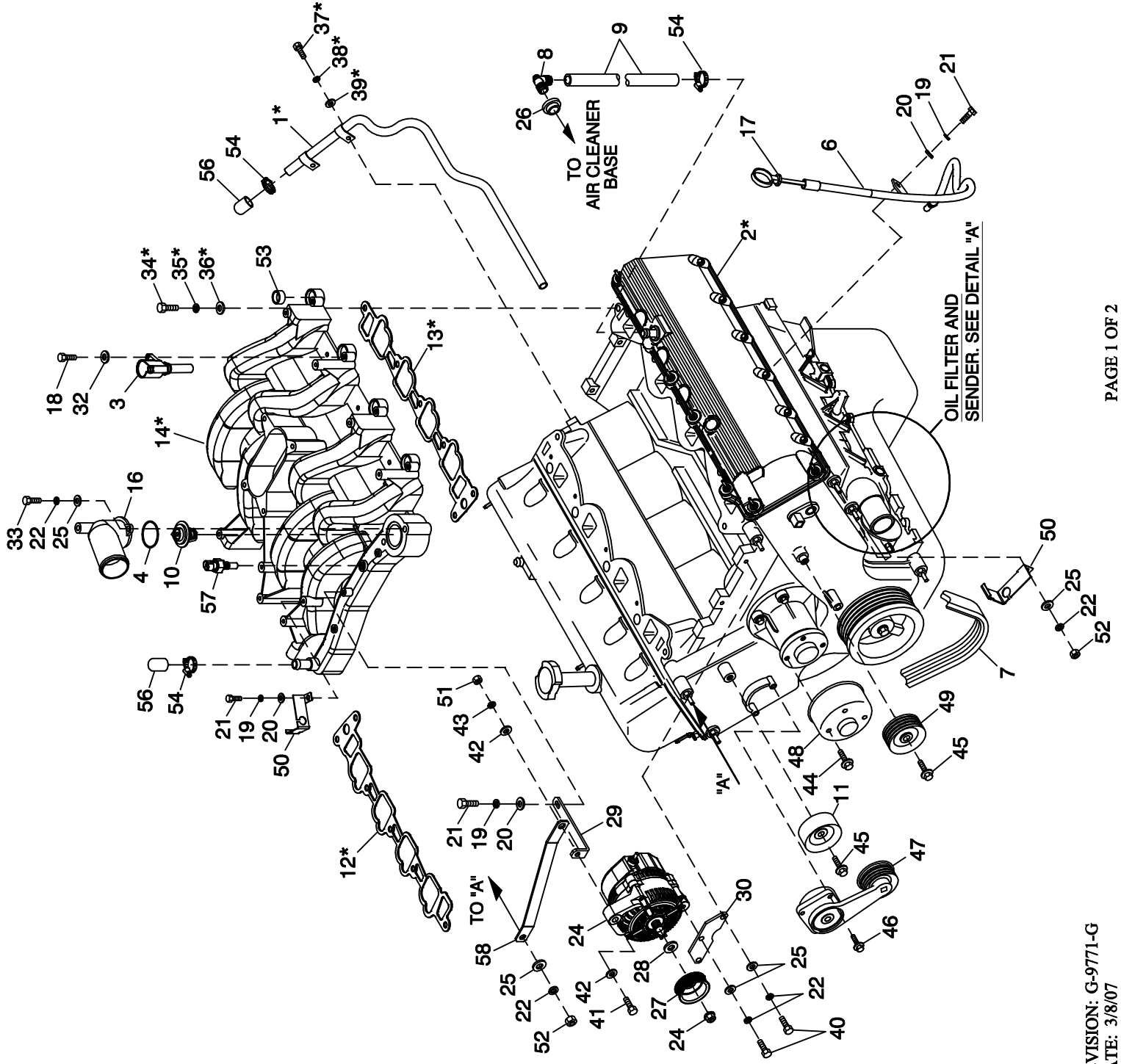

EXPLODED VIEW:  
 ENGINE COMMON PARTS L/H SIDE 5.4L CPL  
 DRAWING #: 0F3848

EXPLODED VIEW: ENGINE COMMON PARTS L/H SIDE 5.4L CPL  
DRAWING #: 0F3848

GROUP D

APPLICABLE TO:

ITEM	PART #	QTY.	DESCRIPTION
1 *	0F3883	1	TUBE HEATER WATER
2 *	0F1960	1	ENGINE 5.4L FORD
3	0F2842	8	IGNITION COIL ASSY FORD
4	0F2843	1	GASKET THERMOSTAT HOUSING FORD
5 **	0D5419	1	OIL FILTER FORD V-10 ENGINE
6	0F2849	1	TUBE OIL LEVEL INDICATOR FORD
7	0D3488G	1	BELT SERPENTINE 65.0" (1800 RPM)
	0D3488L	1	SERPENTINE BELT (66.0") (2650 RPM)
	0D3488K	1	SERPENTINE BELT (68.3") (3600 RPM)
8	057795A	1	BARBED EL 90 3/4 PLASTIC
9	059057	1	HOSE 3/4 ID SAE-30R2 (16.75"LG)
10	0F2844	1	THERMOSTAT ASSY FORD
11	0F2847	1	PULLEY FAN BELT FORD
12 *	0F2839	1	GASKET INTAKE MANIFOLD RIGHT

ITEM	PART #	QTY.	DESCRIPTION
13 *	0F2840	1	GASKET INTAKE MANIFOLD LEFT
14 *	0F1959	1	INTAKE MANIFOLD 5.4L (PLASTIC)
15	055476	1	BUSHING REDUCER 3/8 TO 1/8 GAL
16	0F2851	1	CONNECTION WATER OUTLET FORD
17	0F2848	1	INDICATOR ASSY OIL LEVEL FORD
18	055440	8	SCREW HHC M5-0.8 X 25 G8.8
19	022097	3	WASHER LOCK M6-1/4
20	022473	3	WASHER FLAT 1/4 ZINC
21	042568	3	SCREW HHC M6-1.0 X 20 G8.8
22	022129	6	WASHER LOCK M8-5/16
23	0F4612	1	SENDER OIL PRESSURE 1/8"NPT
24	0E9868A	1	ALTERNATOR DC W/OUT PULLEY
25	022145	7	WASHER FLAT 5/16 ZINC
26	057796	1	GROMMET
27	0F3216	1	PULLEY 80 OD DC ALTERNATOR (1800RPM)
	0F3216B	1	PULLEY 117 OD DC ALTERNATOR (2650 RPM)
	0F3216D	1	PULLEY 160 OD DC ALTERNATOR (3600 RPM)
28	0F3217	1	SPACER DC ALTERNATOR PULLEY
29	0F3287	1	BRKT DC ALTERNATOR UPPER
30	0F3017	1	BRKT DC ALTERNATOR LOWER
31	0F5991	1	HARN ENG 5.4L H-100 (NOT SHOWN)
32	051713	8	WASHER FLAT M5
33	042914	2	SCREW HHC M8-1.25 X 90 G8.8
34 *	051731	9	SCREW HHC M8-1.25 X 50 G8.8
35 *	022129	9	WASHER LOCK M8-5/16
36 *	022145	9	WASHER FLAT 5/16-M8 ZINC
37 *	051756	2	SCREW HHC M10-1.5 X 20 G8.8
38 *	046526	2	WASHER LOCK M10
39 *	022131	2	WASHER FLAT 3/8-M10 ZINC
40	039253	3	SCREW HHC M8-1.25 X 20 G8.8
41	064416	1	SCREW HHC M10-1.5 X 45 G8.8 FT
42	022131	2	WASHER FLAT 3/8-M10 ZINC
43	046526	1	WASHER LOCK M10
44	0D8027	4	SCREW WP PULLEY M8-1.25 X 19
45	0D8025	2	BOLT HEX FL HD M8-1.25 X 28
46	0D8026	3	BOLT HEX FL HD M8-1.25 X 31
47	0D8030	1	TENSIONER ENG. AUTOMATIC BELT
48	0F2846	1	PULLEY WATER PUMP FORD (1800RPM)
	0D8029	1	PULLEY ENGINE WATER PUMP (2650 & 3600RPM)
49	0D8028	1	PULLEY GROOVED ENGINE IDLER
50	0F2776A	2	BRACKET SIGNAL CONDITIONER
51	045772	1	NUT HEX M10-1.5 G8 YEL CHR
52	045771	2	NUT HEX M8-1.25 G8 YEL CHR
53	0E0992A	8	PLUG EXPANSION 14 OD
54	057823	3	CLAMP HOSE #10 .56-1.06
55 ***	029333A	2	TIE WRAP UL 7.4" X .19" BLK (NOT SHOWN)
56	0F6151	2	CAP RUBBER
57	0E0502	1	TEMPERATURE SENDER, DELPHI
58	0F4308	1	BRACKET DC ALT STABILIZER
59	036277	1	ELBOW 90D STREET 1/8

\* NOTE: PART OF ENGINE MAKE P/N 0F3902.

\*\* NOTE: I/N 5 IS PART OF I/N 2.

\*\*\* NOTE: I/N 55 IS FOR HOLDING SENSOR TO I/N 50.

**GROUP D**

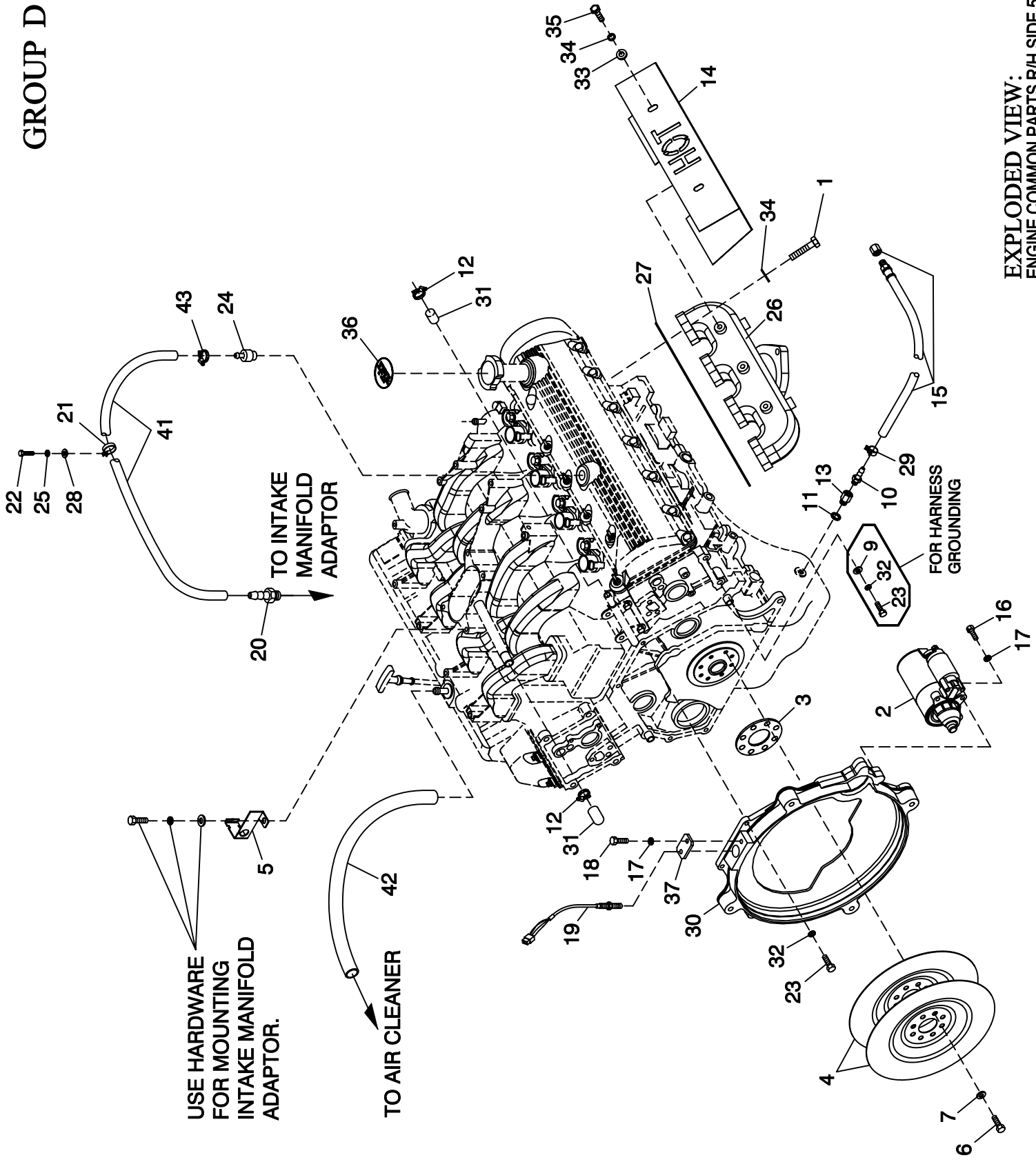

**EXPLODED VIEW:  
ENGINE COMMON PARTS R/H SIDE 5.4L CPL  
DRAWING #: 0F3850**



## EXPLODED VIEW: ENGINE COMMON PARTS R/H SIDE 5.4L CPL

DRAWING #: 0F3850

GROUP D

APPLICABLE TO:

ITEM	PART #	QTY.	DESCRIPTION
1	0D9913	16	SCREW SHC M8-1.25 X 35 SS
2	0E9747	1	STARTER 12 VOLT
3	0F3514	1	SPACER FLEXPATE 5.4L/6.8L (1800 RPM ONLY)
4	0F3903C	1	FLEX PLATE 2 POLE 5.4L & 6.8L (1800 RPM UNITS ONLY)
	0F3903C	2	FLEX PLATE 2 POLE 5.4L & 6.8L (3600 RPM UNITS ONLY)
5	0F2776A	1	BRACKET, SIGNAL CONDITIONER
6	0D5417	8	SCREW HHC M10-1.0 X 25 G10.9
7	0F3844	8	WASHER FLAT .43 X 1.00
8*	029333A	1	TIE WRAP UL 7.4" X .19" BLK (NOT SHOWN)
9	022131	1	WASHER FLAT 3/8-M10 ZINC
10	055596	1	BARBED STR 3/8 NPT X 3/8
11	057772	1	WASHER NYLON .565
12	057823	2	CLAMP HOSE #10 .56 - 1.06
13	057765	1	ADAPTER M14-1.50 X 3/8 NPT
14	0F3534	2	HEAT SHLD EXHAUST MANIFOLD
15	069860E	1	HOSE DRAIN ASSY 28"
16	049821	2	SCREW SHC M8-1.25 X 30 G12.9
17	022129	4	WASHER LOCK M8-5/16
18	039253	1	SCREW HHC M8-1.25 X 20 G8.8
19	0D2244M	1	ASSY MAGPICKUP(3/8-24 MALE)
20	044118	REF	BARBED STR 1/2 NPT X 5/8
21	055934M	1	CLAMP VINYL .75 X .343 Z
22	047411	1	SCREW HHC M6-1.0 X 16 G8.8
23	071623	4	SCREW SHC M10-1.5 X 55 G12.9
24	0D6742	1	VALVE PCV (FORD 6.8L)
25	022097	1	WASHER LOCK M6-1/4
26	0F1820	2	MACHINED MANIFOLD EXHAUST 5.4L
27	0F1818	2	GASKET EXHAUST MANIFOLD
28	022473	1	WASHER FLAT 1/4-M6 ZINC
29	048031J	1	HOSE CLAMP BAND 5/8"
30	0F2929	1	ENGINE ADAPTER 5.4L/6.8L
31	077996	2	CAP HOSE
32	046526	6	WASHER LOCK M10
33	070008	8	WASHER FLAT M8 SS
34	070006	24	WASHER LOCK M8 SSTL
35	0D2608	8	SCREW HHC 5/16-18 X 1/2 SSTL
36	0F5114	1	DECAL REFER TO OWNERS MANUAL
37	0F5454	1	PLATE MAG PICK-UP ADAPTOR
41	047290	1	HOSE 3/8 ID SINGLE BRAID (15" LG)
42	059057	1	HOSE 3/4 ID SAE-30R2
43	040173	1	CLAMP HOSE #5.5 .62-.62

\* NOTE: I/N 8 IS FOR HOLDING SENSOR TO I/N 5.

# GROUP B

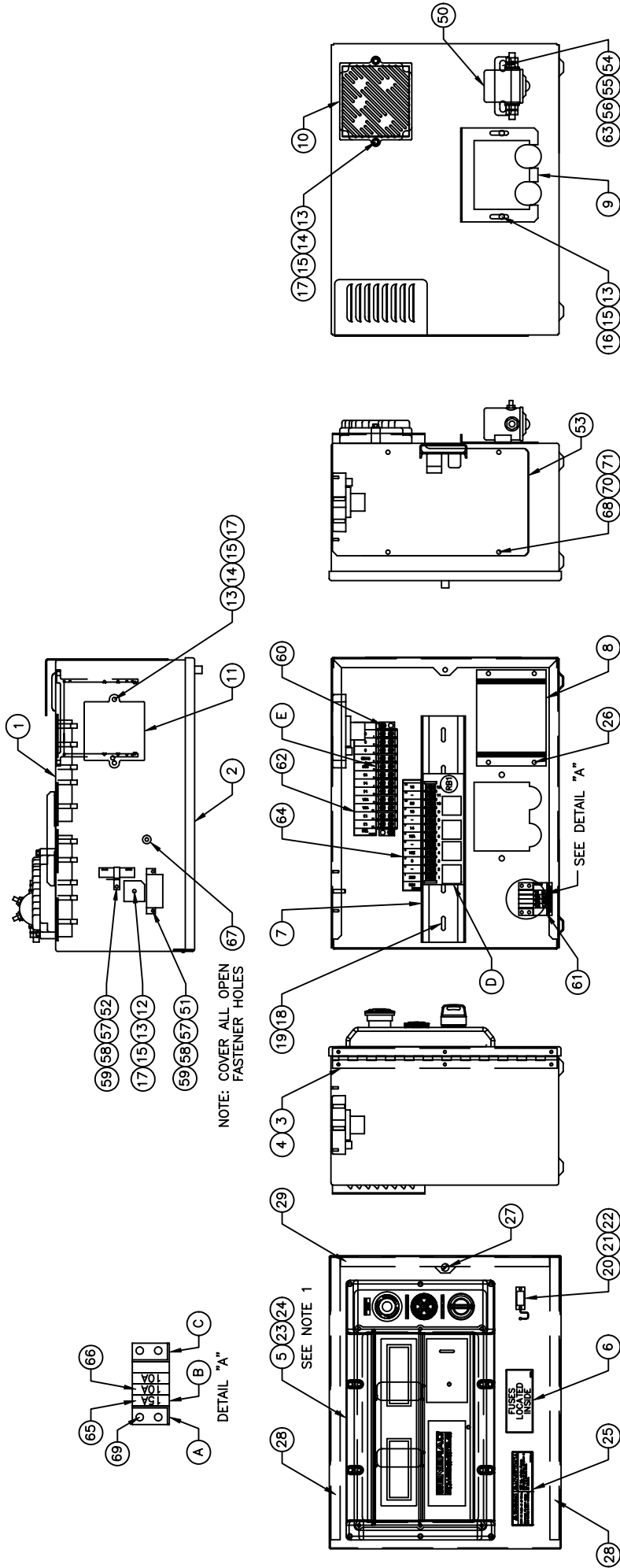

NOTE 1: ITEM 30 ATTACHES TO CONTACT ON REAR OF ITEM 5

EXPLODED VIEW:  
H PANEL 2A BATTERY CHARGER  
DRAWING #: 0G4139D

REVISION: -A-  
DATE: 12/13/06

**EXPLODED VIEW: H PANEL 2A BATTERY CHARGER**  
**DRAWING #: 0G4139D**

**GROUP B**

APPLICABLE TO:

ITEM	PART #	QTY.	DESCRIPTION
COMPONENTS INCLUDED IN 0G4139E			
1	0F1823CST06	1	ENCL H/G CONTROL PANEL
2	0F1824AST06	1	COVER CONTROL PANEL
3	0F2606	1	HINGE CONTINUOUS H PANEL
4	036261	6	RIVET POP .125 X .275 SS
5	0F5763	1	ASSY PROGRAMMED H-100
6	0F1732	1	DECAL FUSES LOCATED INSIDE
7	0E9764	1	RAIL SNAPTRACK PCB HOLDER BULK (12"LG)
8	0F1725C	1	ASSY PCB 2AMP 12V UL BATT CHGR
9	0F1958	1	PLATE HARNESS CLAMP
10	0F2256	1	ASSY PCB PWR AVR W/AMP HEADER
11	0E3161	1	ASSY PCB BOSCH GOV DRIVER
12	029673	1	DIO BRIDGE 25A 600V
13	049226	7	WASHER LOCK M5
14	079224	4	SCREW PPHM M5-0.8 X 30 SS
15	051713	7	WASHER FLAT M5
16	0F5886	2	SCREW HHPM M5-0.8 X 12
17	051716	5	NUT HEX M5-0.8 G8 YEL CHR
18	043180	3	WASHER FLAT M4
19	0C3990	3	SCREW PHTT M4-0.7 X 10 ZYC
20	0F4333	1	CONN DUST CAP W/CHAIN DB9
21	0F5883	1	WASHER FLAT M3.5
22	0F5884	1	SCREW PHTT M3.5-0.6 X 10
23	055014	10	SCREW PPHM M4-0.7 X 8 BLX OX
24	022264	10	WASHER LOCK #8-M4
25	0G3546	1	DECAL WRN BATT CHR 12/24V BI
26	0C2265	4	SCREW PHTT M4-0.7 X 12 ZYC
27	0G3648	1	M5-0.8 CAPTIVE PANEL KNLD HD
28	0F6305	2	SEAL COVER 3.18 X 12.7 X 382
29	0F6305A	1	SEAL COVER 3.18 X 12.7 X 283
30	0G4329	1	HARNESS H-PNL INTEGRATED SW (NOT SHOWN)
COMPONENTS INCLUDED IN WIRE HARNESS			
A	0F1263	1	ADPTR RH SIDE WICKMANN 178.6191
B	0F1262	4	HOLDER FUSE WICKMANN 178.6150
C	0F1264	1	ADPTR LH SIDE WICKMANN 178.6192
D	0E9049B	1	ASSY PCB G-PANEL RELAY 12VDC
E	055911	1	BLOCK TERM 20A 12 X 6 X 1100V
COMPONENTS NOT INCLUDED IN 0G4139E OR WIRE HARNESS			
50	056739	1	RELAY CONTACTOR 12VDC
51	-	1	DPE BREAKER SEE DRAWING 0F9280
52	-	1	BOOST RESISTOR SEE DRAWING 0F9280
53	0F2627A	1	COVER CONTROL PANEL SIDE
54	022287	2	SCREW HHC 1/4-20 X 3/4 G5
55	022473	4	WASHER FLAT M6-1/4
56	022097	2	WASHER LOCK M6-1/4
57	043182	3	WASHER LOCK M3
58	051714	3	NUT HEX M3-0.5 G8 YEL CHR
59	052777	3	WASHER FLAT M3
60	0C2323	2	SCREW PHTT #6-32 X 5/8 ZYC
61	0F5459	1	DECAL CPL CONTROL PANEL FUSES
62	0F5461	1	DECAL CPL 5.4/6.8L TB3
63	022127	2	NUT HEX 1/4-20 STEEL
64	0F5460	1	DECAL CPL 5.4/6.8L RELAY BOARD
65	0E7403C	1	FUSE ATO TYPE 15 AMP (BLUE)
66	0E7403B	2	FUSE ATO TYPE 10 AMP (RED)
67	0F6145	A/R	SEAL WEATHER .45"DIA
68	091526	4	SCREW PPHM M5-0.8 X 12 ZNC
69	0C2699	2	SCREW PHTT #6-32 X 3/8 ZYC
70	051713	4	WASHER FLAT M5
71	049226	4	WASHER LOCK M5

# GROUP E

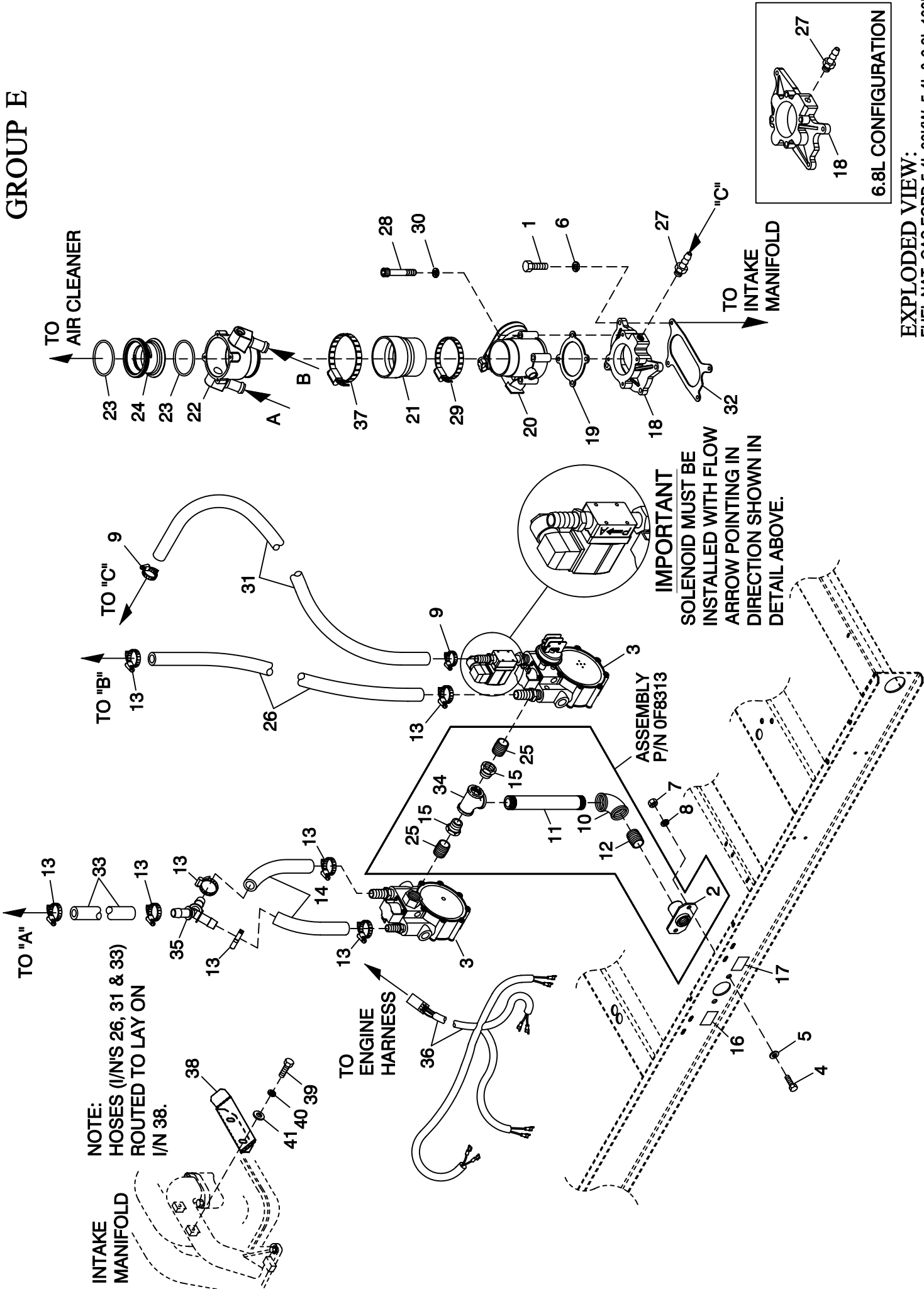

**NOTE:**  
 HOSES (I/N'S 26, 31 & 33)  
 ROUTED TO LAY ON  
 I/N 38.

**IMPORTANT**  
 SOLENOID MUST BE  
 INSTALLED WITH FLOW  
 ARROW POINTING IN  
 DIRECTION SHOWN IN  
 DETAIL ABOVE.

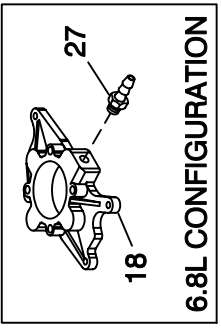

**6.8L CONFIGURATION**

**EXPLODED VIEW:**  
 FUEL NAT. GAS FORD 5.4L 80KW, 5.4L & 6.8L 100KW  
 DRAWING #: 0F3593

## EXPLODED VIEW: FUEL NATURAL GAS FORD 5.4L 80KW, 5.4L &amp; 6.8L 100KW

DRAWING #: 0F3593

GROUP E

APPLICABLE TO:

ITEM	PART #	QTY.	DESCRIPTION
1	049721	4	SCREW HHC M6-1.0 X 35 G8.8 BLK
2	065908	1	SUPPORT NAT GAS SOLENOID
3	0F6261G	1	REGULATOR ASSM 5.4L 80KW NG
	0F6261C	1	REGULATOR ASSM 5.4L 100KW NG
	0F6261D	1	REGULATOR ASSM 6.8L 100KW NG
4	052617	2	SCREW HHC M12-1.75 X 20 G8.8
5	022304	2	WASHER FLAT 1/2 ZINC
6	022129	4	WASHER LOCK M8-5/16
7	045773	2	NUT HEX M12-1.75 G8 YEL CHR
8	022195	2	WASHER LOCK 1/2
9	040173	2	CLAMP HOSE #5.5 .62-.62 (5.4L)
	0C7649	2	CLAMP HOSE .38-.87 (6.8L 100KW)
10	030131	1	ELBOW 90D 1-1/4 NPT
11	031015	1	NIPPLE PIPE 1-1/4 NPT X 3
12	039130	1	NIPPLE CLOSE 1.25 NPT X 1.625
13	057822	9	CLAMP HOSE #8 .53-1.00
14	059057	2	HOSE 3/4 ID SAE-30R2 (42" LG)
15	0A8064	2	BSHG RDCR HEX 1-1/4-3/4
16	0D1509	1	DECAL INLET PRESSURE
17	050279	1	DECAL FUEL INLET NG
18	0F2756A	1	MACHINING INTAKE ADAPTOR 60MM (5.4L FORD)
	0D2696B	1	ADAPTOR THROTTLE BODY (BOSCH) (6.8L FORD GEARBOX)
19	0E4390	1	GASKET GOVERNOR ACTUATOR
20	0E4392	1	ACTUATOR BOSCH 60 GOVERNOR
21	0F0960	1	REDUCER 3.0" TO 2.75" TURBO
22	0F3885	1	MIXER 40/60MM ACTUATOR ASSY
23	0G3167	2	O-RING 2-3/4 X 3/32 X 2-15/16
24	0F3691C	1	VENTURI THROTTLE 38MM (5.4L 80KW)
	0F3691D	1	VENTURI THROTTLE 40MM (5.4L FORD 2-POLE 100KW)
	0F3691E	1	VENTURI THROTTLE 42MM (6.8L FORD GEARBOX 100KW)
25	026915	2	NIPPLE CLOSE 3/4 X 1.375
26	059057	1	HOSE 3/4 ID SAE-30R2 (42" LG)
27	035461	1	BARBED STR 1/4 NPT X 3/8 (5.4L 80KW & 100KW NG)
	081017	1	BARBED STR 1/4 NPT X 1/2 (6.8L 100KW NG)
28	046580	4	SCREW SHC M6-1.0 X 45 G12.9
29	039294	1	CLAMP HOSE #44 2.31-3.25
30	022097	4	WASHER LOCK M6-1/4
31	047290	1	HOSE 3/8 ID SINGLE BRAID (42" LG)
	052223	1	HOSE 1/2 ID SAE-30R2 FUELOIL (42" LG) (6.8L 100KW)
32	0D2698	1	GASKET ADAPTER THROT BODY (6.8L FORD ONLY)
33	059057	1	HOSE 3/4 ID SAE-30R2 (42" LG)
34	064346	1	PIPE TEE 1-1/4 NPT
35	0F4408	1	Y CONNECTOR 500 SERIES BARBS
36	0F6279	1	HARNES FUEL JUMPER DUAL REG
37	066212	1	CLAMP HOSE #52 2.81-3.75
(1) 38	0G46350ST03	1	BRACKET, HOSE RISER
(1) 39	042568	2	SCREW HHC M6-1.0 X 20 G8.8
(1) 40	022097	2	WASHER LOCK M6-1/4
(1) 41	049811	2	WASHER FLAT M6

(1) G6.8L UNITS ONLY

# GROUP E

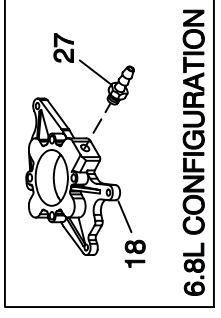
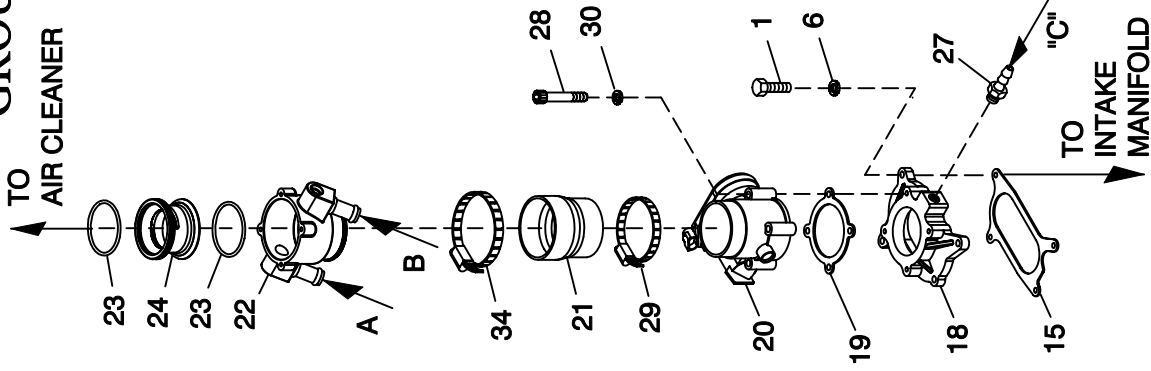

EXPLODED VIEW:  
FUEL P VAPOR C5 CPL  
DRAWING #: 0F6529

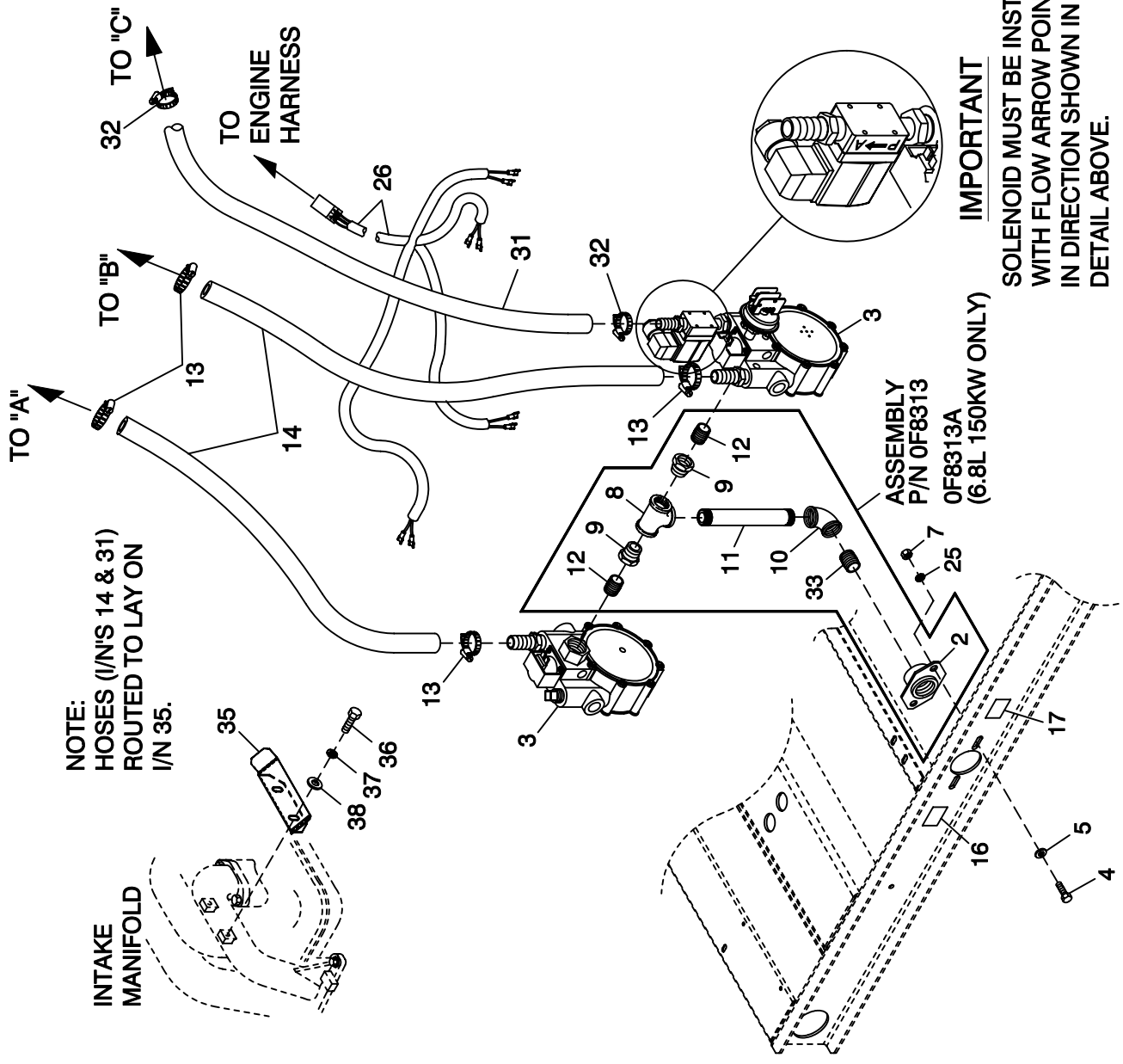

## EXPLODED VIEW: FUEL LP VAPOR C5 CPL

DRAWING #: 0F6529

GROUP E

APPLICABLE TO:

ITEM	PART #	QTY.	DESCRIPTION
1	033212	4	SCREW HHC 5/16-18 X 1-1/4 G5
2	065908	1	SUPPORT NAT GAS SOLENOID
3	0F6261H	1	REGULATOR ASSM 5.4L 80KW LPV (5.4L 80KW)
	0F6261J	1	REGULATOR ASSM 5.4L 100KW LPV (5.4L 100KW)
	0F6261K	1	REGULATOR ASSM 6.8L 100KW LPG (6.8L 100KW)
	0F6261L	1	REGULATOR ASSM 6.8L 130KW LPV (6.8L 130KW)
	0F6261M	1	REGULATOR ASSM 6.8L 150KW LPV (6.8L 150KW)
4	052617	2	SCREW HHC M12-1.75 X 20 G8.8
5	022304	2	WASHER FLAT 1/2 ZINC
6	022129	4	WASHER LOCK M8-5/16
7	045773	2	NUT HEX M12-1.75 G8 YEL CHR
8	064346	1	PIPE TEE 1-1/4 NPT
9	0A8064	2	BSHG RDCR HEX 1-1/4-3/4
10	030131	1	ELBOW 90D 1-1/4 NPT
11	031015	1	NIPPLE PIPE 1-1/4 NPT X 3
	088963	1	NIPPLE PIPE 1.25 NPT X 5.5 BL IRN (6.8L 150KW ONLY)
12	026915	2	NIPPLE CLOSE 3/4 X 1.375
13	057823	4	CLAMP HOSE #10 .56-1.06
14	059057	2	HOSE 3/4 ID SAE-30R2 (45" LG)
15	0D2698	1	GASKET ADAPTER THROT BODY
16	0D1509	1	DECAL INLET PRESSURE
17	050280	1	DECAL FUEL INLET LPG (LP VAPOR APPLICATION)
18	0D2696B	1	ADAPTOR THROTTLE BODY (BOSCH) (6.8L)
	0F2756A	1	MACHINING INTAKE ADAPTOR 60MM (5.4L)
19	0E4390	1	GASKET GOVERNOR ACTUATOR
20	0E4392	1	ACTUATOR BOSCH 60 GOVERNOR
21	0F0960	1	REDUCER 3.0" TO 2.75" TURBO
22	0F3885	1	MIXER 40/60MM ACTUATOR ASSY
23	0G3167	2	O-RING 2-3/4 X 3/32 X 2-15/16
24	0F3691B	1	VENTURI THROTTLE 36MM (5.4L 80KW)
	0F3691D	1	VENTURI THROTTLE 40MM (5.4L 100KW)
	0F3691E	1	VENTURI THROTTLE 42MM (6.8L 100KW)
	0F3691F	1	VENTURI THROTTLE 44MM (6.8L 130KW)
	0F3691J	1	VENTURI THROTTLE 50MM (6.8L 150KW)
25	022195	2	WASHER LOCK 1/2
26	0F6279	1	HARNESS FUEL JUMPER DUAL REG
27	081017	1	BARBED STR 1/4 NPT X 1/2
28	046580	4	SCREW SHC M6-1.0 X 45 G12.9
29	039294	1	CLAMP HOSE #44 2.31-3.25
30	022097	4	WASHER LOCK M6-1/4
31	047290	1	HOSE 3/8 ID SINGLE BRAID (42" LG)
32	040173	2	CLAMP HOSE #5.5 .62-.62
33	039130	1	NIPPLE CLOSE 1.25 NPT X 1.625
34	066212	1	CLAMP HOSE #52 2.81-3.75
(1) 35	0G46350ST03	1	BRACKET, HOSE RISER
(1) 36	042568	2	SCREW HHC M6-1.0 X 20 G8.8
(1) 37	022097	2	WASHER LOCK M6-1/4
(1) 38	049811	2	WASHER FLAT M6

(1) G6.8L UNITS ONLY

# GROUP F

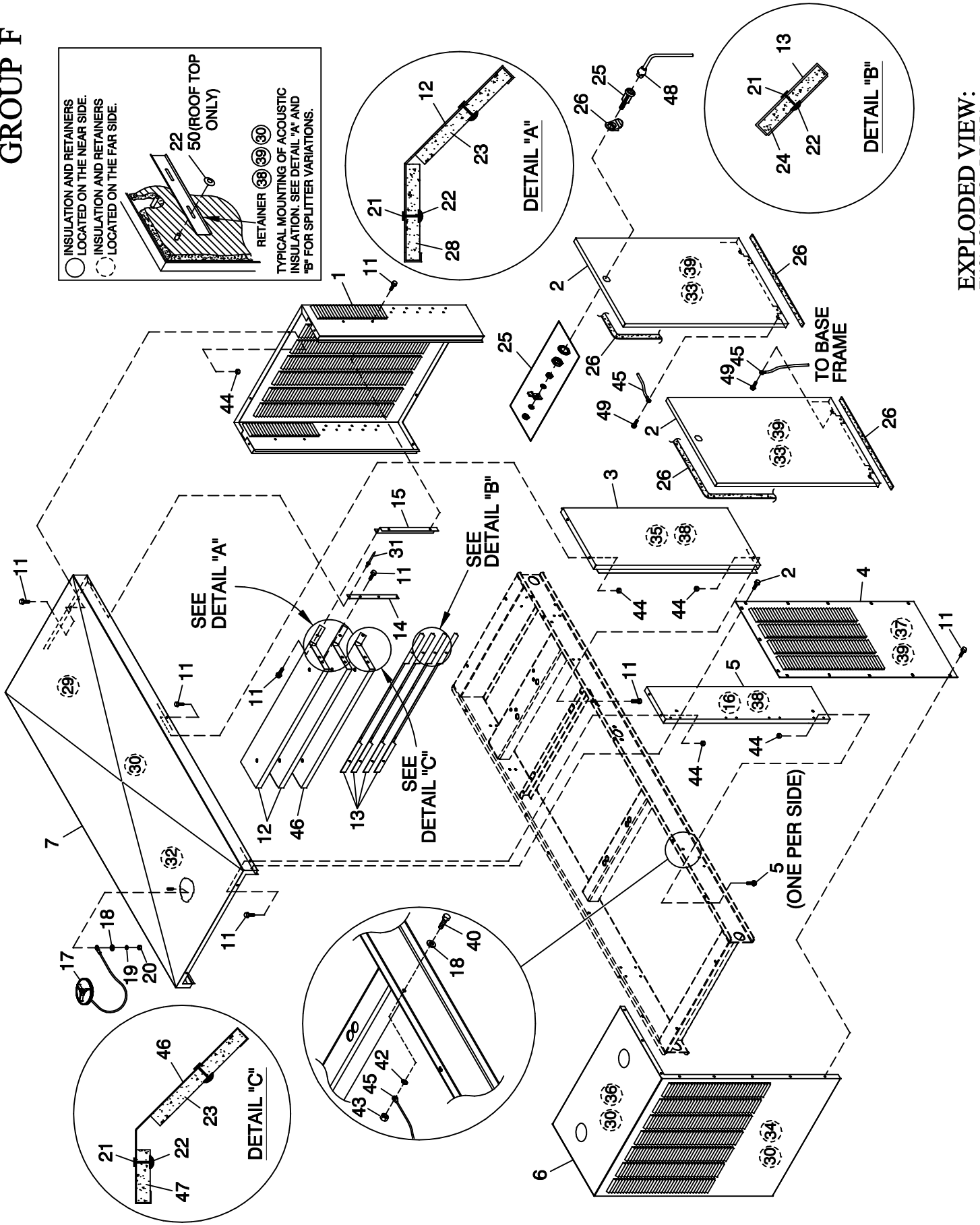
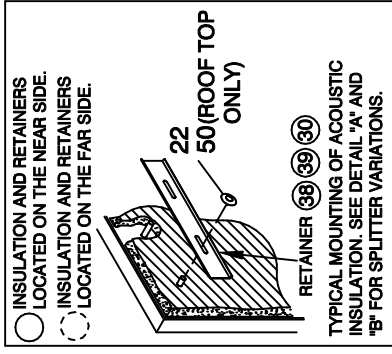

EXPLODED VIEW:  
 ENCLOSURE C5 PRT LBL  
 DRAWING #: 0G2901



APPLICABLE TO:

ITEM	PART #	QTY.	DESCRIPTION
(2) 1	0F5873	1	REAR WRAP C5
(2) 2	0F5868	4	DOOR C5
(2) 3	0F5872	2	CENTER SUPPORT C5
(2) 4	0F5871	2	DISCHARGE DUCT LH & RH SIDE C5
(2) 5	0F5869	2	FRONT CORNERS C5
(2) 6	0F5870	1	DISCHARGE CENTER DUCT C5
(2) 7	0F5867	1	ROOF C5 ALUM
11	0C2454	86	SCREW THF M6-1 X 16 N WA Z/JS
12	0F2766	2	SPLITTER
13	0F3181	4	SPLITTER SHORT
14	0F3185	2	STRINGER SPLITTER C3
15	0F3416	2	SUPPORT SPLITTER C5 130KW
16	0F3949	2	INSULATION CORNER POST
17	0F4487A	1	ASSEMBLY COVER ACCESS
18	022473	5	WASHER FLAT 1/4-M6 ZINC
19	022097	1	WASHER LOCK M6-1/4
20	022127	1	NUT HEX 1/4-20 STEEL
21	0F3072	20	INSULATION RETAINMENT HANGER
22	078115	58	WASHER SELF LOCKING DOME #4-40
23	0F3949B	3	INSULATION SPLITTER
24	0F3949A	4	INSULATION SHORT LOUVER
25	0F5048D	4	WISE-ACTION LATCH SLOTTED CIR
26	0E5968	1	GASKET EXTRUDED TRIM (566" LG)
27	0F5049	4	TAB PULL
28	0F3949L	2	INSULATION SPLITTER SML
29	0F3949E	1	INSULATION ROOF TOP REAR
30	0F3890A	8	RETAINER INSULATION (740)
31	087233	2	RIVET POP .1875 X .450 SS
32	0F3949C	1	INSULATION ROOF TOP
33	0F3949D	4	INSULATION DOOR
34	0F3949G	1	INSULATION DISCHARGE DUCT
35	0F3949J	2	INSULATION CENTER SUPPORT
36	0F3949K	1	INSULATION DISCHARGE DUCT TOP
37	0F3949F	2	INSULATION INNER DUCT SIDE
38	0F3890B	4	RETAINER INSULATION (820)
39	0F3890	14	RETAINER INSULATION (450)
40	042568	4	SCREW HHC M6-1.0 X 20 G8.8
42	022447	4	WASHER SHAKEPROOF INT 1/4
43	049813	4	NUT HEX M6 X 1.0 G8 YEL CHR
(1) 44	077992	28	NUT HEX LOCK M6-1.0 SS NY INS
45	0912970094	4	ASSY WIRE 14 AWG 34.8" GRN/YEL
46	0F2766A	1	SPLITTER C5
47	0F3949M	1	INSULATION SPLITTER SHRT MPS
48	0F8869D	1	KEY WISE-ACTION LATCH SLOT CIR
49	0E3257	6	SCREW TH-FRM M6 W/CAP SHKPRF W
50	078115A	12	WASHER SELF LOCKING DOME #8-32

(1) ALUMINUM ENCLOSURE NOTE: ALL ENCLOSURE PANELS THAT FASTEN TO THE BASE FRAME MUST BE SECURED USING ITEM 11 & 49 THREAD FORMING FASTENER AND ITEM 44 LOCK NUT. LOCK NUT IS TO BE INSTALLED AFTER THREAD FORMING FASTENER HAS PENETRATED THROUGH EXTRUSIONS IN ENCLOSURE PANELS. ALL ROOF PANELS ARE TO BE SECURED IN THE SAME MANNER.

(2) I/N'S 1 THRU 7, REFER TO CHART BELOW FOR ENCLOSURE COLOR & MATERIAL TYPE.

SUFFIX 1 (MATL.)	SUFFIX 2 (COLOR)
AL (ALUMINUM)	01 (TAN)
	03 (BLACK)
ST (STEEL)	05 (WHITE)
	07 (G-FORCE)
	08 (TELECOM)
	09 (CRAFTSMAN)
	OR (CUSTOM)

GENERIC EXAMPLE: SUFFIX 1      SUFFIX 2  
 OF19870AL 01

COMPONENTS LOCATED ON ENGINE

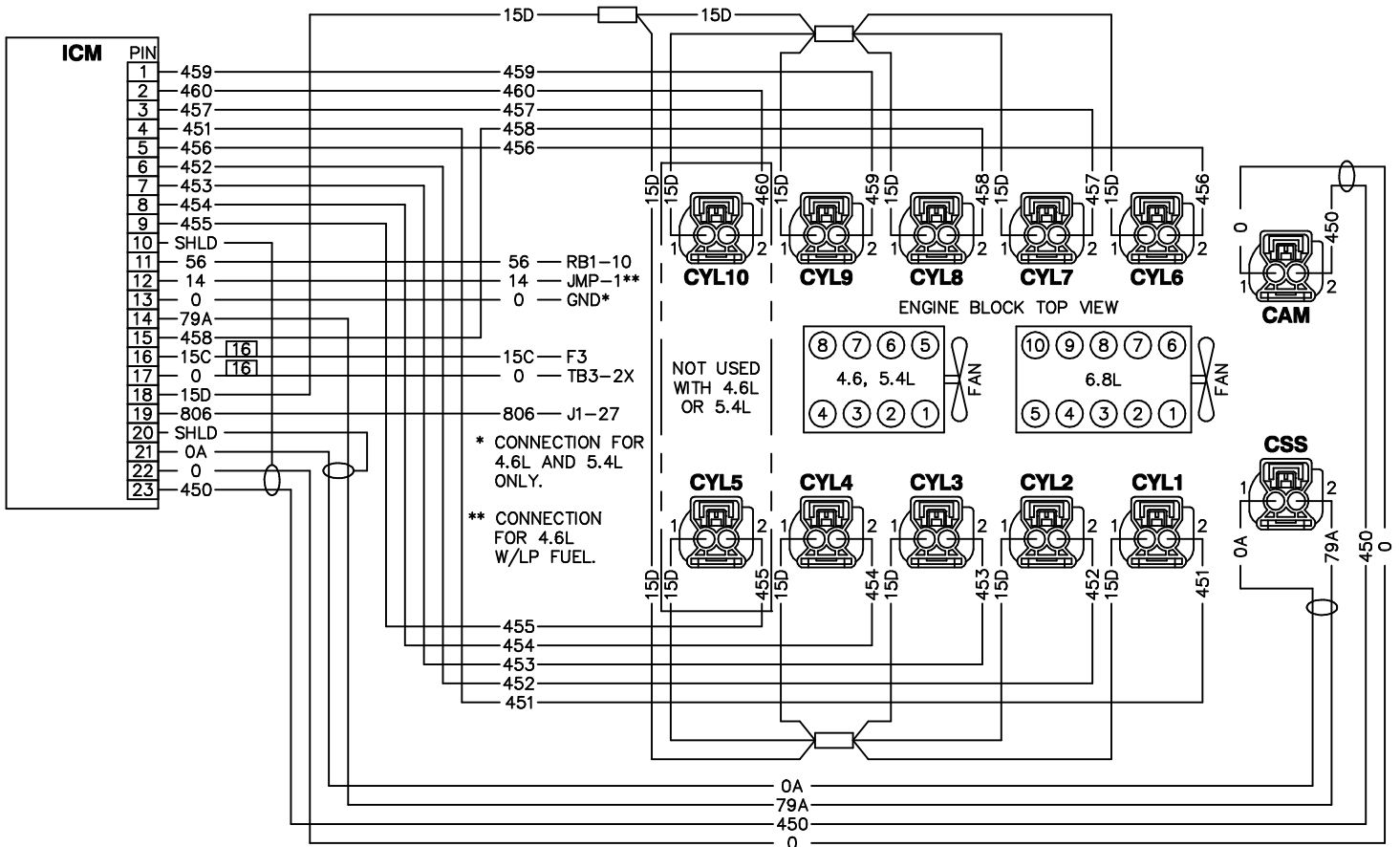

NOTE: ALL WIRES 18 AWG 300V UL LISTED UNLESS SHOWN OTHERWISE

AWG SIZE

S1, S2 & S3 ARE 600V UL LISTED

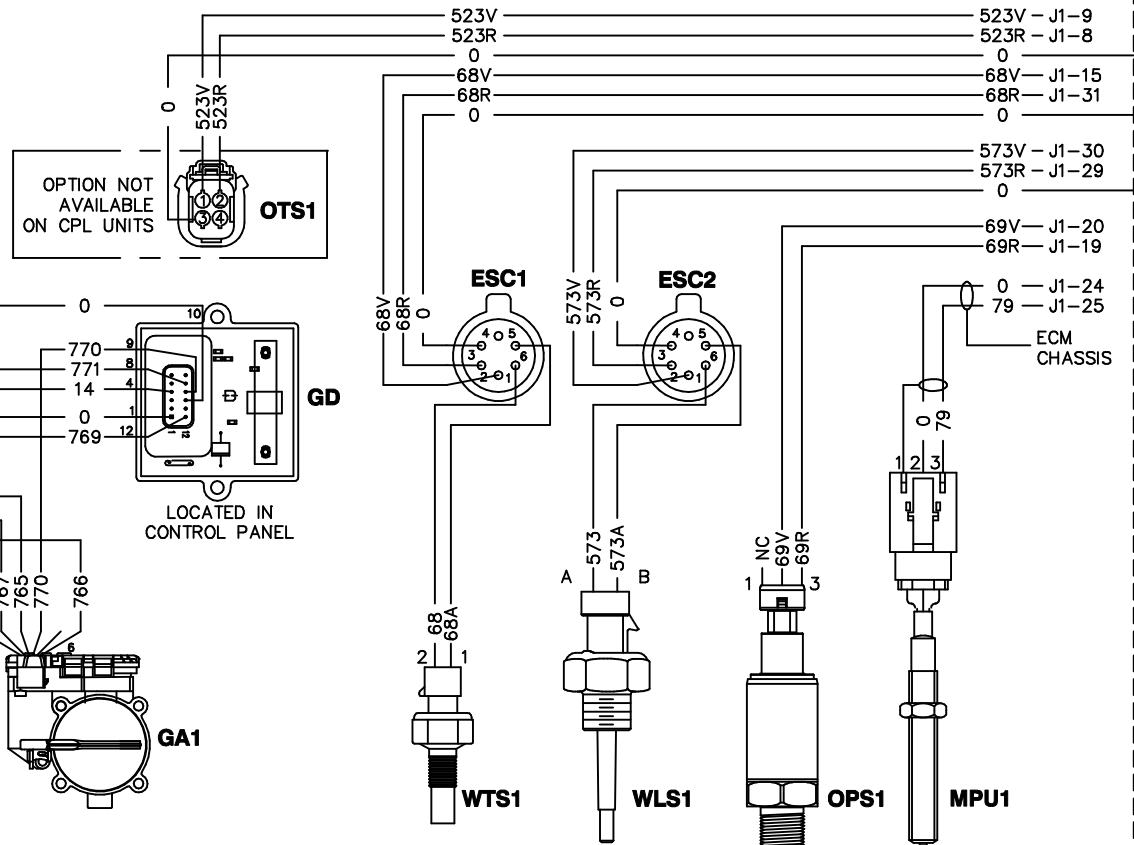

COMPONENTS LOCATED ON ENGINE

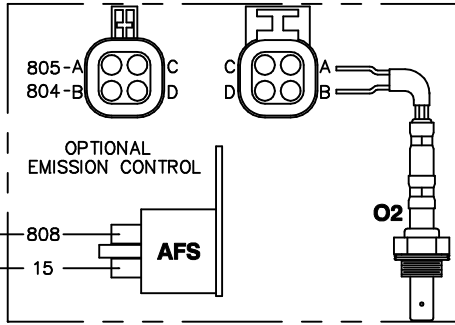

CENTER TERMINAL NOT USED

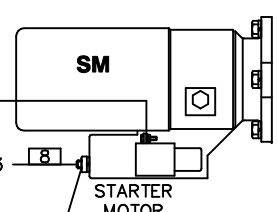
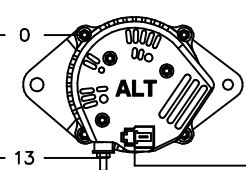
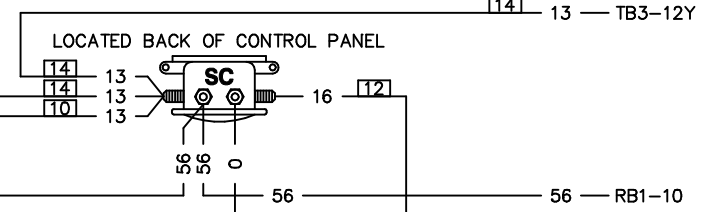
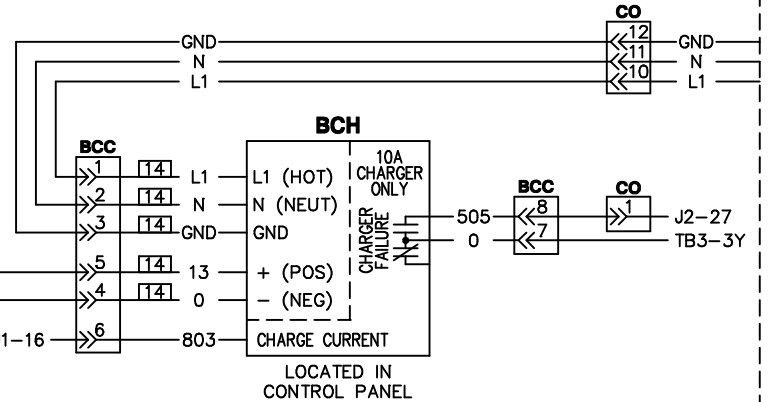
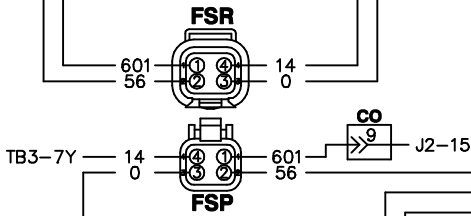
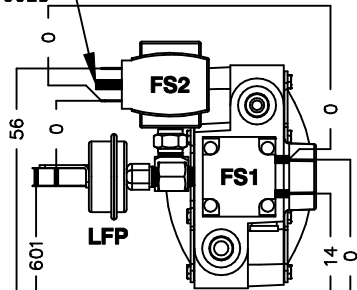

WIRE LOCATIONS MAY CHANGE ON GROUND BAR.

- ESC3-3 — 0
- TB3-1Y — 0
- \*CM-13 — 0

\* CONNECTION FOR 4.6L & 5.4L ONLY.

COMPONENTS LOCATED IN ALTERNATOR CONNECTION BOX

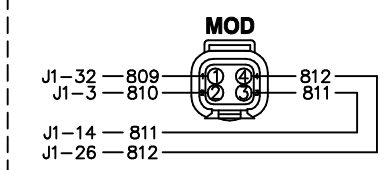
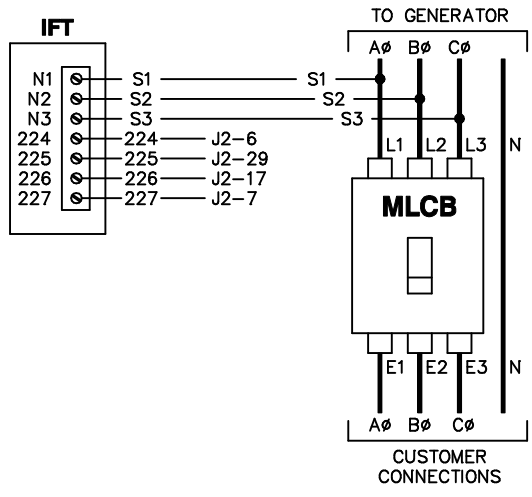
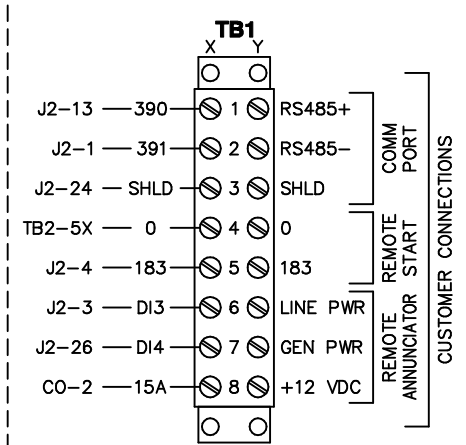
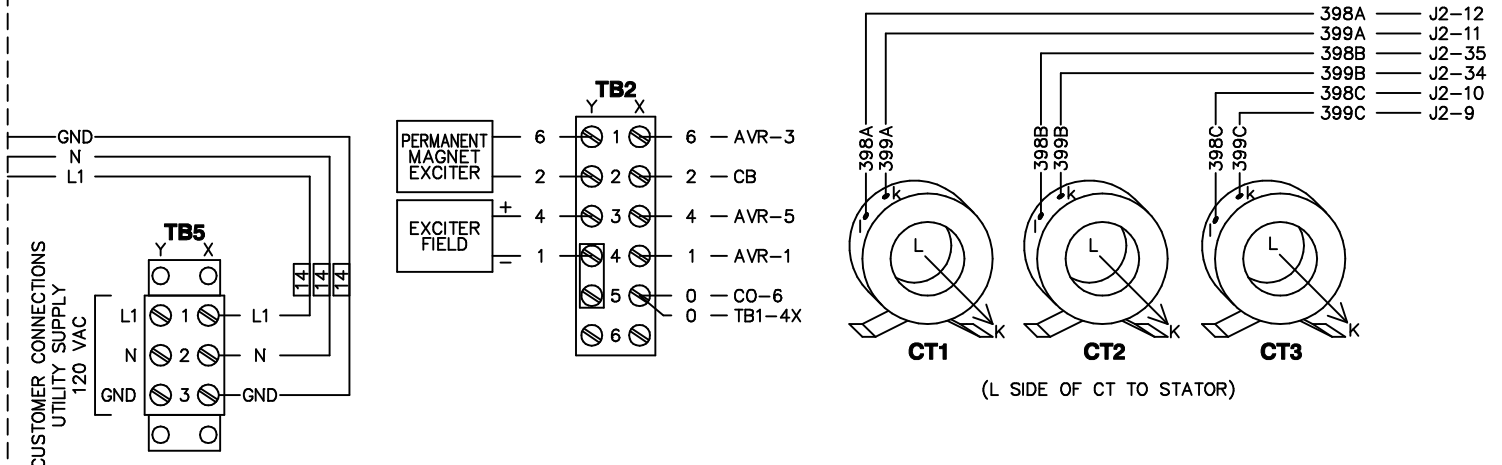

LEGEND	
AFS	- AIR/FUEL SOLENOID
AH1	- ALARM HORN
ALT	- DC CHARGE ALTERNATOR
AVR	- AUTOMATIC VOLTAGE REGULATOR
BCC	- BATTERY CHARGER CONNECTOR
BCH	- BATTERY CHARGER
CAM	- CAMSHAFT SENSOR
CB	- CIRCUIT BREAKER, DPE
CO	- CROSSOVER CONNECTOR
COM	- COMMUNICATIONS PORT (9 PIN D-SUB)
CSS	- CRANKSHAFT SENSOR
CT	- CURRENT TRANSFORMER
CYL	- CYLINDER IGNITION COIL
DB	- DIODE BRIDGE
ECM	- ELECTRONIC CONTROL MODULE (H-100)
ES1	- EMERGENCY STOP SWITCH
ESC	- ELECTRONIC SIGNAL CONDITIONER
F	- FUSE
FS	- FUEL SOLENOID
FSP	- FUEL SOLENOID PLUG
FSR	- FUEL SOLENOID RECEPTACLE
GA1	- GOVERNOR ACTUATOR
GD	- GOVERNOR DRIVER
GND	- GROUND BAR CONNECTION
ICM	- IGNITION CONTROL MODULE
IFT	- INTERFACE TRANSFORMER
J	- ELECTRONIC CONTROL MODULE CONNECTIONS
JMP	- JUMPER CONNECTION FOR NATURAL GAS
LFP	- LOW FUEL PRESSURE SWITCH
MLCB	- MAIN LINE CIRCUIT BREAKER
MOD	- MODEM CONNECTOR
MPU1	- MAG. PICK UP
O2	- OXYGEN SENSOR
OPS1	- OIL PRESSURE SENDER
OTS1	- OIL TEMP. SENDER
R1	- RESISTOR
RB1	- RELAY BOARD
RB1A	- RELAY BOARD CONNECTOR
SC	- START CONTACTOR
SM	- STARTER MOTOR CONNECTIONS
SW1	- AUTO/MANUAL SELECT SWITCH
SWC	- OPERATOR SWITCH CONNECTOR
TB	- TERMINAL BLOCKS
WLS1	- COOLANT LEVEL SENDER
WTS1	- COOLANT TEMP. SENDER

## COMPONENTS LOCATED IN CONTROL PANEL

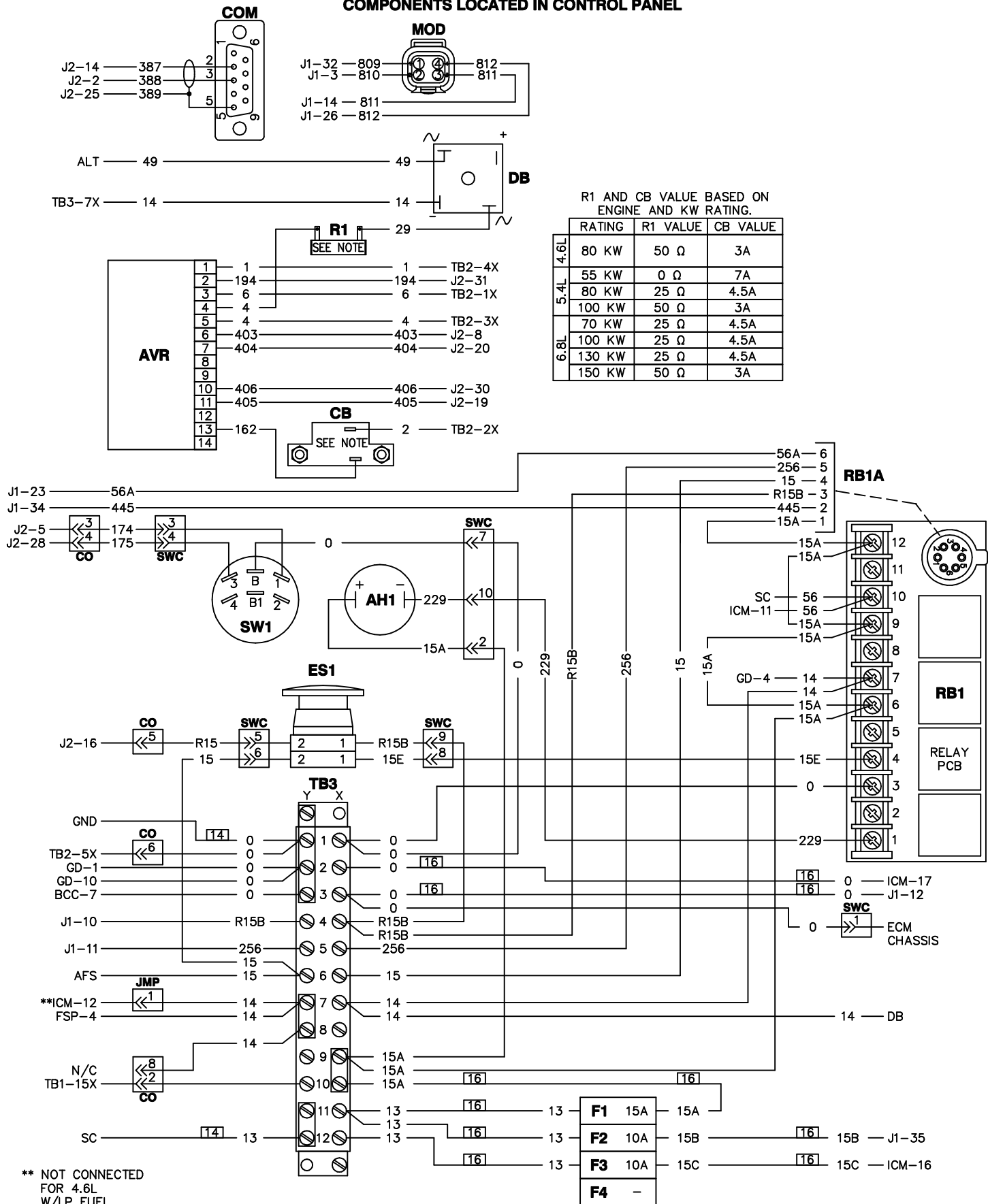

R1 AND CB VALUE BASED ON ENGINE AND KW RATING.

	RATING	R1 VALUE	CB VALUE
4.6L	80 KW	50 Ω	3A
	55 KW	0 Ω	7A
5.4L	80 KW	25 Ω	4.5A
	100 KW	50 Ω	3A
6.8L	70 KW	25 Ω	4.5A
	100 KW	25 Ω	4.5A
	130 KW	25 Ω	4.5A
	150 KW	50 Ω	3A

\*\* NOT CONNECTED FOR 4.6L W/LP FUEL.

**GD CONNECTOR**

PIN	WIRE	TO	FUNCTION
1	0	GND	NOTE 1
4	14	RB1-7	NOTE 3
8	771	GA1-1	THROTTLE DRIVE LO
9	770	GA1-4	THROTTLE DRIVE HI
10	0	GND	NOTE 1
12	769	J1-33	THROTTLE PWM

**AVR CONNECTOR**

PIN	WIRE	TO	FUNCTION
1	1	FIELD	- FIELD
2	194	J2-31	+12VDC
3	6	PME	PME OUTPUT
4	4	R1	+ FIELD
5	4	FIELD	+ FIELD
6	403	J2-8	GATE TRIGGER B
7	404	J2-20	GATE TRIGGER A
10	406	J2-30	ZERO CROSSING I/P
11	405	J2-19	GROUND (ISO)
13	162	CB	PME OUTPUT (AFTER CB)

**ICM - IGNITION MODULE CONNECTOR**

PIN	WIRE	TO	FUNCTION
1	459	CYL9	IGNITION COIL DRIVE 9
2	460	CYL10	IGNITION COIL DRIVE 10
3	457	CYL7	IGNITION COIL DRIVE 7
4	451	CYL1	IGNITION COIL DRIVE 1
5	456	CYL6	IGNITION COIL DRIVE 6
6	452	CYL2	IGNITION COIL DRIVE 2
7	453	CYL3	IGNITION COIL DRIVE 3
8	454	CYL4	IGNITION COIL DRIVE 4
9	455	CYL5	IGNITION COIL DRIVE 5
10	SHLD	CUT	CAMSHAFT SENSOR DRAIN
11	56	RB1-10	STARTER RELAY OUT
12	14	RB1-7	NOTE 3
13	0	GND	NOTE 1
14	79A	CSS-2	CRANKSHAFT SENSOR +
15	458	CYL8	IGNITION COIL DRIVE 8
16	15C	F3	NOTE 7
17	0	GND	NOTE 1
18	15D	CYL1-CYL10	IGNITION COIL PWR
19	806	J1-27	IGNITION ALARM
20	SHLD	CUT	CRANKSHAFT SENSOR DRAIN
21	0A	CSS-1	CRANKSHAFT SENSOR -
22	0	CAM-1	CAMSHAFT SENSOR -
23	450	CAM-2	CAMSHAFT SENSOR +

**ENGINE CONTROL MODULE CONNECTIONS**

**J1**

PIN	WIRE	TO	FUNCTION
3	810	MOD-2	EXTERNAL MODEM GROUND
4	805	O2	OXYGEN SENSOR RTN (OPTION)
5	804	O2	OXYGEN SENSOR + (OPTION)
10	R15B	RB1A-3/ES1	OVERSPEED/WATCHDOG
11	256	RB1A-5	FUEL RELAY
12	0	GND	NOTE 1
14	811	MOD-3	DCD
15	68V	WTS-1	COOLANT TEMP +
16	803	BCH	BAT CHARGER CURRENT
17	766R	GA-2	THROTTLE POS RTN
18	766V	GA-1	THROTTLE POS +
19	69R	OPS-3	OIL PRESS RTN
20	69V	OPS-1	OIL PRESS +
21	808	AFS	AIR/FUEL SOLENOID (OPTION)
23	56A	RB1A-6	STARTER RELAY
24	0	MPU1-2	MPU1 SIGNAL (-)
25	79	MPU1-3	MPU1 SIGNAL (+)
26	812	MOD-4	ENABLE
27	806	ICM-19	IGNITION ALARM
29	573R	WLS-2	COOLANT LVL RTN
30	573V	WLS-1	COOLANT LVL +
31	68R	WTS-2	COOLANT TEMP RTN
32	809	MOD-1	+12
33	769	GD-12	THROTTLE PWM
34	445	RB1A-2	ALARM RELAY
35	15B	F2	NOTE 6

**J2**

PIN	WIRE	TO	FUNCTION
1	391	CUST CON	RS485- (XFER SW)
2	388	COM-3	RS232 TX (GENLINK)
3	DI3	CUST CON	LINE POWER SIGNAL
4	183	CUST CON	REMOTE START
5	174	SW1	"AUTO" START
6	224	IFT	V SENSE GEN A PH
7	227	IFT	V SENSE RTN
8	403	AVR-6	AVR GATE TRIGGER B
* 9	399C	CT3	GEN C PH CURRENT -
* 10	398C	CT3	GEN C PH CURRENT +
11	399A	CT1	GEN A PH CURRENT -
12	398A	CT1	GEN A PH CURRENT +
13	390	CUST CON	RS485+ (XFER SW)
14	387	COM-2	RS232 RX (GENLINK)
15	601	LFP	LOW FUEL PRESSURE
16	R15	ES1	EMERGENCY STOP
* 17	226	IFT	V SENSE GEN C PH
19	405	AVR-11	AVR GROUND
20	404	AVR-7	AVR GATE TRIGGER A
24	SHLD	CUST CON	RS485 DRAIN (XFER SW)
25	389	COM-5	RS232 COM (GENLINK)
26	DI4	CUST CON	GEN POWER SIGNAL
27	505	BCH	BAT CHARGER FAIL
28	175	SW1	"MANUAL" START
29	225	IFT	V SENSE GEN B PH
30	406	AVR-10	AVR ZERO CROSSING I/P
31	194	AVR-2	AVR +12VDC
34	399B	CT2	GEN B PH CURRENT-
35	398B	CT2	GEN B PH CURRENT+

\* - CONNECTIONS NOT USED IN 1Ø UNITS.

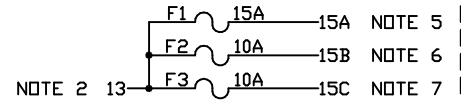
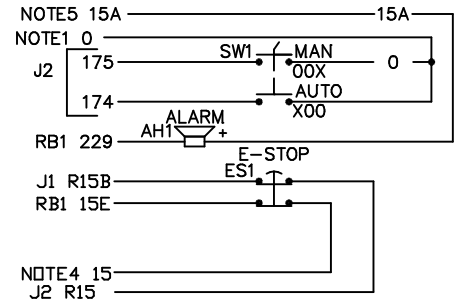
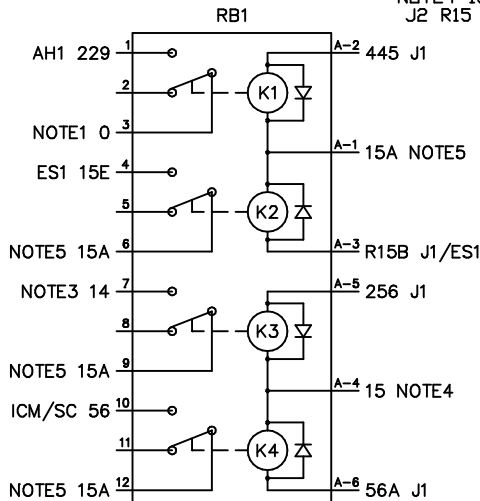
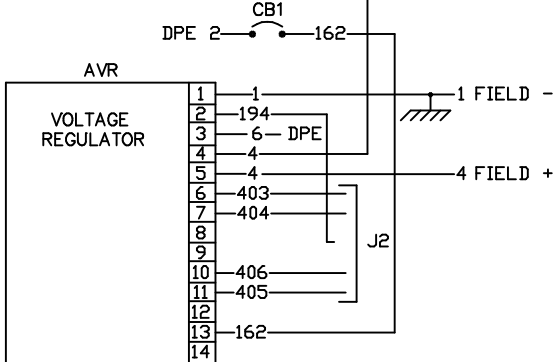
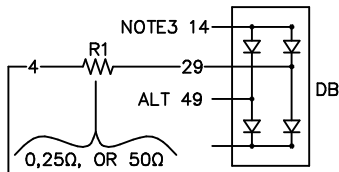
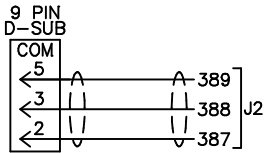
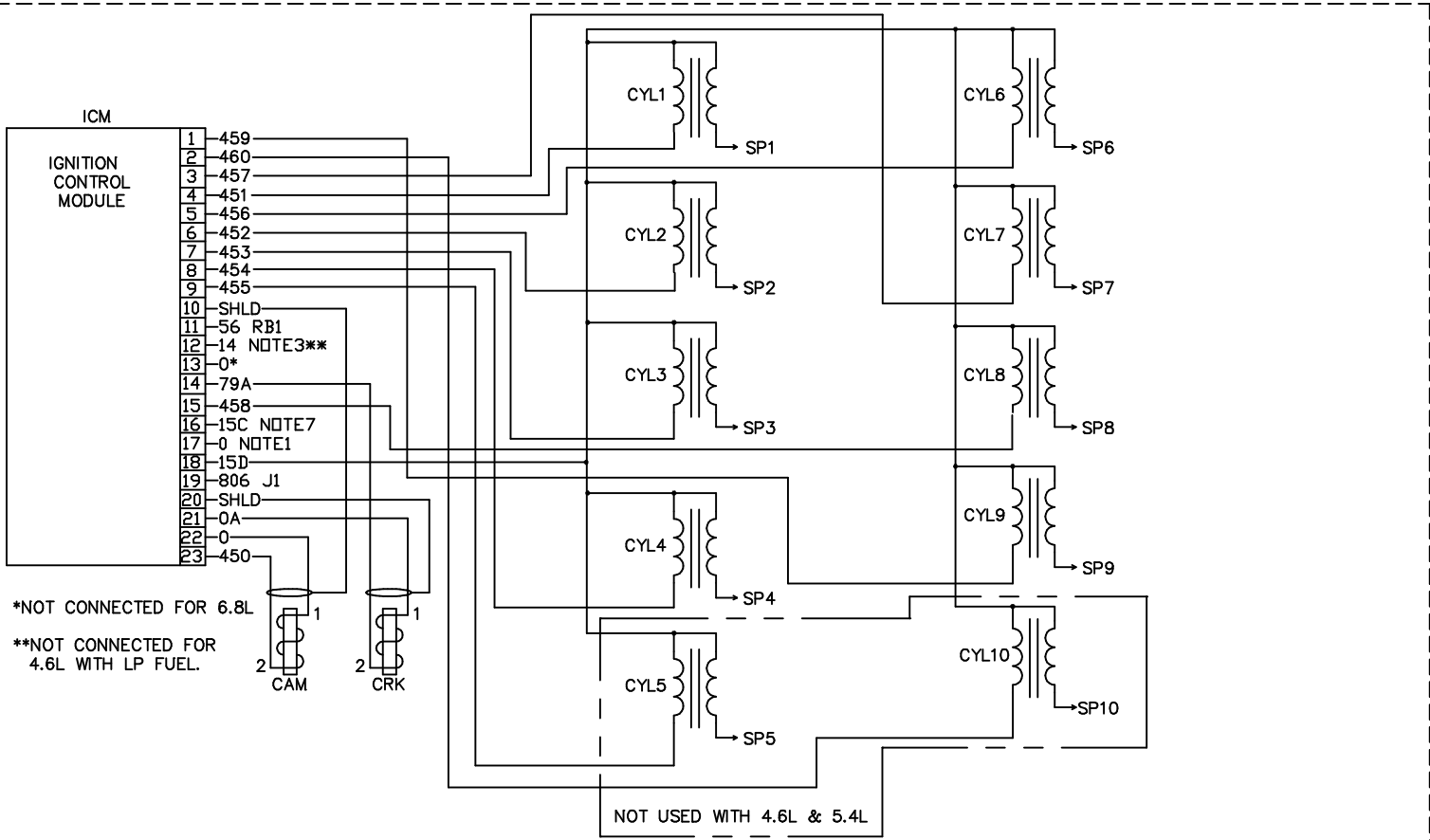

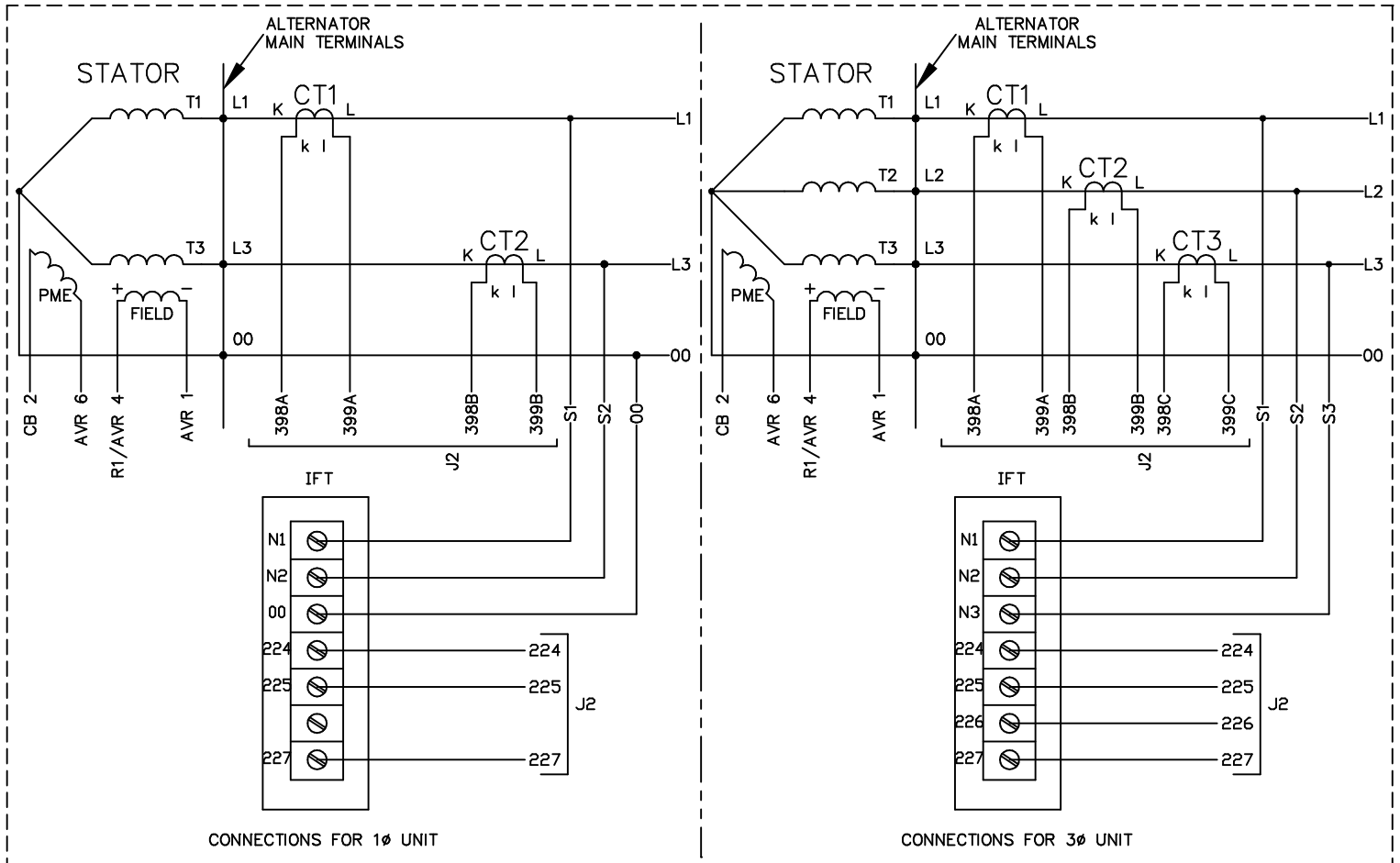

ALTERNATOR CONNECTION BOX

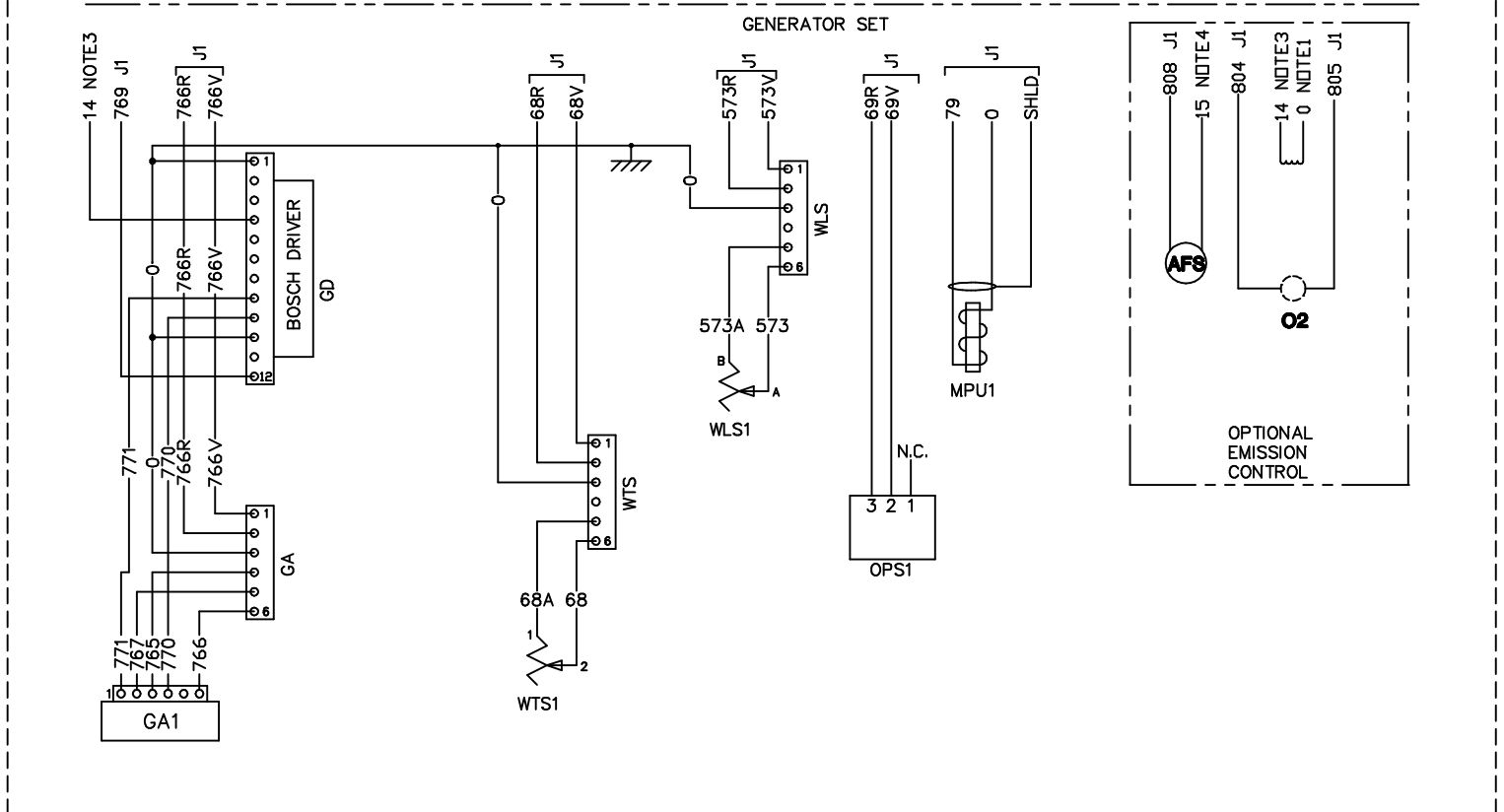



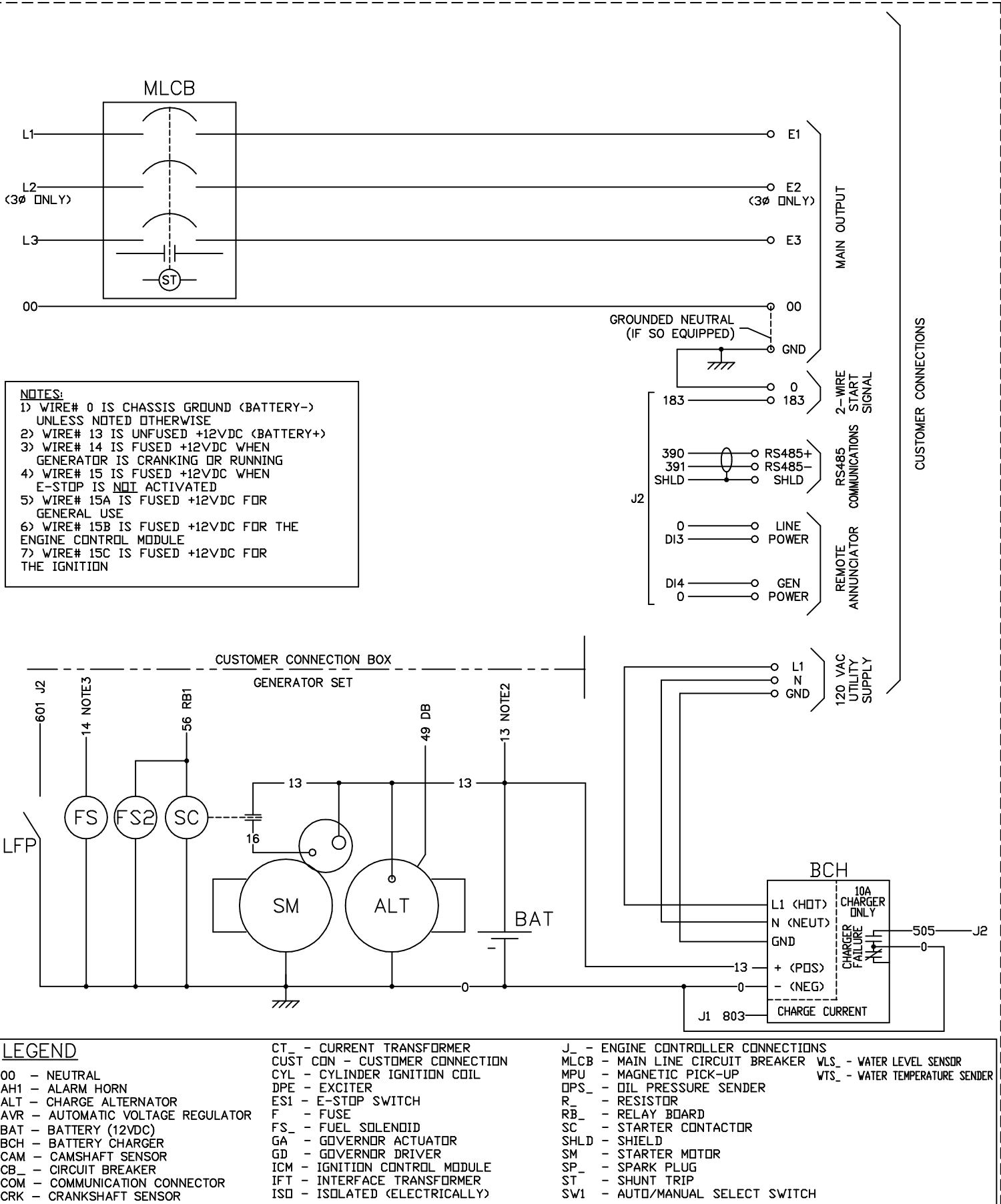

WEIGHT DATA	
5. 4L 80KW	- 1167KG (2573 LB)
5. 4L 100KW	- 1048KG (2311 LB)
6. 8L 100KW	- 1227KG (2705 LB)
6. 8L 130KW	- 1303KG (2873 LB)
6. 8L 150KW	- 1209KG (2666 LB)
WOODEN SHIPPING SKIDS INCREASE OVERALL WEIGHT 79KG (175 LB)	

**NOTES:**

- 1) MINIMUM RECOMMENDED CONCRETE PAD SIZE: 1240(48.8') WIDE X 3230 (127.2') LONG. REFERENCE INSTALLATION GUIDE SUPPLIED WITH UNIT FOR CONCRETE PAD GUIDELINES.
- 2) ALLOW SUFFICIENT ROOM ON ALL SIDES OF THE GENERATOR FOR MAINTENANCE AND SERVICING. THIS UNIT MUST BE INSTALLED IN ACCORDANCE WITH CURRENT APPLICABLE NFPA 37 AND NFPA 70 STANDARDS AS WELL AS ANY OTHER FEDERAL, STATE AND LOCAL CODES FOR MINIMUM DISTANCES FROM OTHER STRUCTURES.
- 3) CIRCUIT BREAKER INFORMATION:  
SEE SPECIFICATION SHEET WITHIN OWNERS MANUAL.
- 4) INSIDE STUB-UP AREA FOR AC LOAD LEAD CONDUIT CONNECTION, NEUTRAL CONNECTION, BATTERY CHARGER 120 VOLT AC (<.5 AMP MAX.) CONNECTION, AND ACCESS TO TRANSFER SWITCH CONTROL WIRES. REMOVE FRONT COVER FOR ACCESS.
- 4A) FIELD CUT HOLE IS ONLY REQUIRED FOR MOUNTING OF GENERATOR ON AN EXISTING PAD.
- 5) REFERENCE OWNERS MANUAL FOR LIFTING WARNINGS.
- 6) REMOVE EITHER LEFT OR RIGHT HAND SIDE PANEL TO ACCESS EXHAUST MUFFLERS AND FAN BELT.

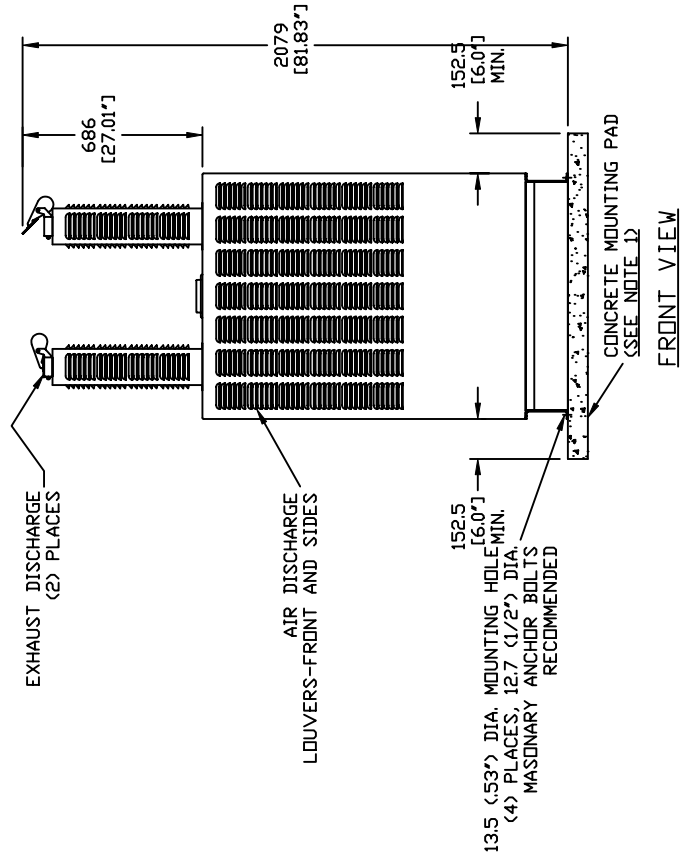

**EXPLODED VIEW:**  
**INSTALL CPL 5.4L/6.8L**  
**DRAWING #: 0F6289**

# GROUP G

CENTER OF GRAVITY	
1310 (51.6') - 80KW 5.4L	
1405 (55.3') - 100KW 5.4L	
1275 (50.2') - 100KW 6.8L	
1230 (48.4') - 130KW 6.8L	
1315 (51.8') - 150KW 6.8L	

SERVICE ITEM ACCESSIBILITY CHART

SERVICE ITEM	80KW 5.4L	100KW 6.8L	130KW 6.8L	150KW 6.8L
OIL FILL CAP	THRU RIGHT FRONT DOOR	THRU LEFT FRONT DOOR	THRU LEFT FRONT DOOR	THRU LEFT FRONT DOOR
OIL DIP STICK	THRU LEFT FRONT DOOR	THRU LEFT FRONT DOOR	THRU LEFT FRONT DOOR	THRU LEFT FRONT DOOR
OIL FILTER	THRU LEFT FRONT DOOR	THRU LEFT FRONT DOOR	THRU LEFT FRONT DOOR	THRU LEFT FRONT DOOR
OIL DRAIN HOSE	THRU LEFT FRONT DOOR	THRU LEFT FRONT DOOR	THRU LEFT FRONT DOOR	THRU LEFT FRONT DOOR
RADIATOR DRAIN HOSE	THRU LEFT FRONT DOOR	THRU LEFT FRONT DOOR	THRU LEFT FRONT DOOR	THRU LEFT FRONT DOOR
AIR CLEANER ELEMENT	EITHER FRONT DOORS	EITHER FRONT DOORS	EITHER FRONT DOORS	EITHER FRONT DOORS
SPARK PLUGS	BOTH FRONT DOORS	BOTH FRONT DOORS	BOTH FRONT DOORS	BOTH FRONT DOORS
MUFFLERS	SEE NOTE 6	SEE NOTE 6	SEE NOTE 6	SEE NOTE 6
FAN BELT	SEE NOTE 6	SEE NOTE 6	SEE NOTE 6	SEE NOTE 6
BATTERY	THRU RIGHT REAR DOOR	THRU RIGHT REAR DOOR	THRU RIGHT REAR DOOR	THRU RIGHT REAR DOOR
*GEARBOX FILL & DRAIN	THRU RIGHT REAR DOOR	THRU RIGHT REAR DOOR	THRU RIGHT REAR DOOR	THRU RIGHT REAR DOOR

\*NOTE: EXCLUDING 5.4L 100KW & 6.8L 150KW UNITS  
 REFERENCE OWNERS MANUAL FOR PERIODIC  
 REPLACEMENT PART LISTINGS

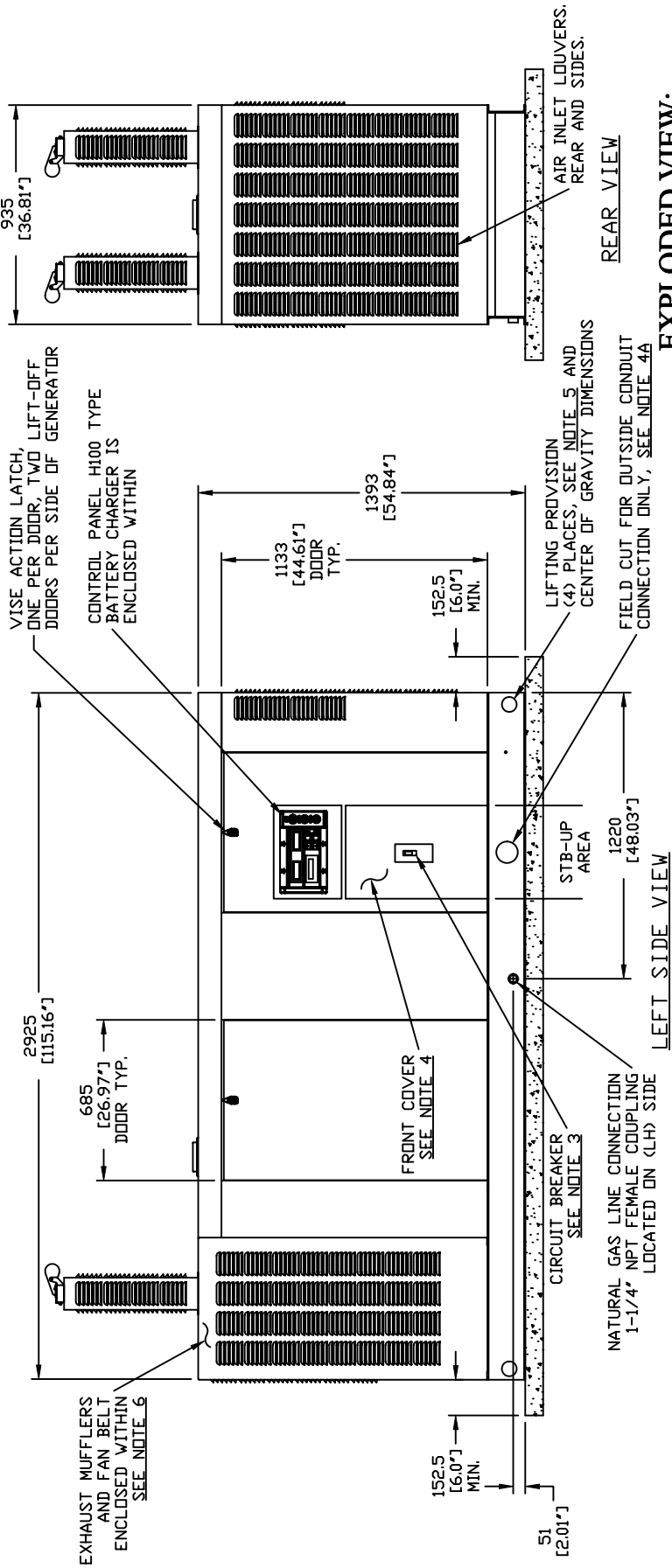
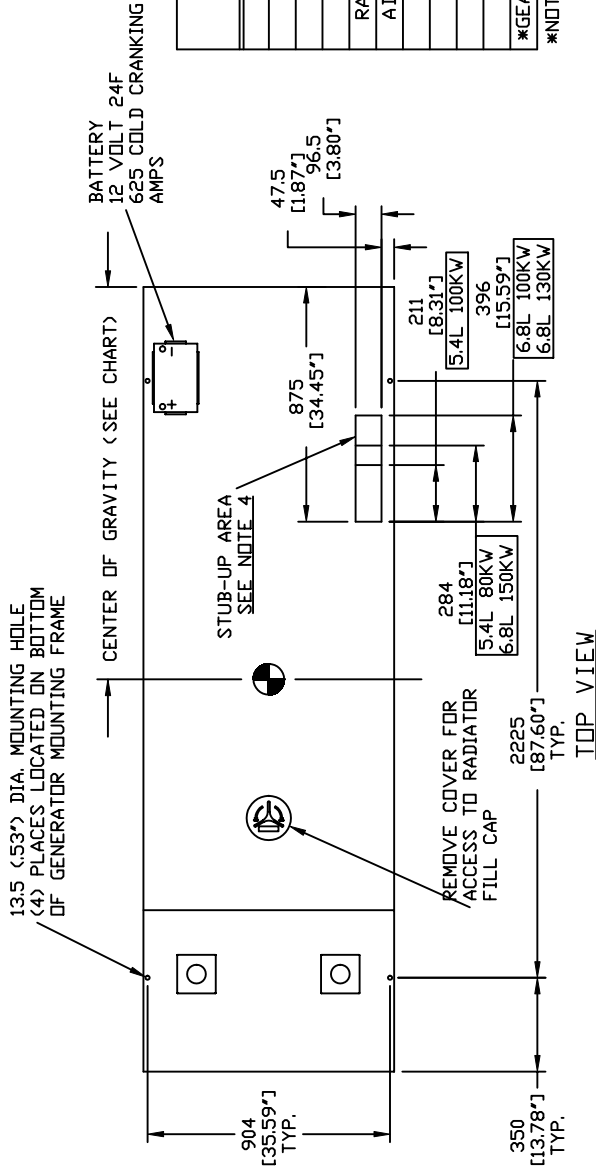

**EXPLODED VIEW:**  
 INSTALL CPL 5.4L/6.8L  
 DRAWING #: 0F6289

# GROUP G

## OPTION 1 - SINGLE PHASE, H-100 CONTROL PANEL

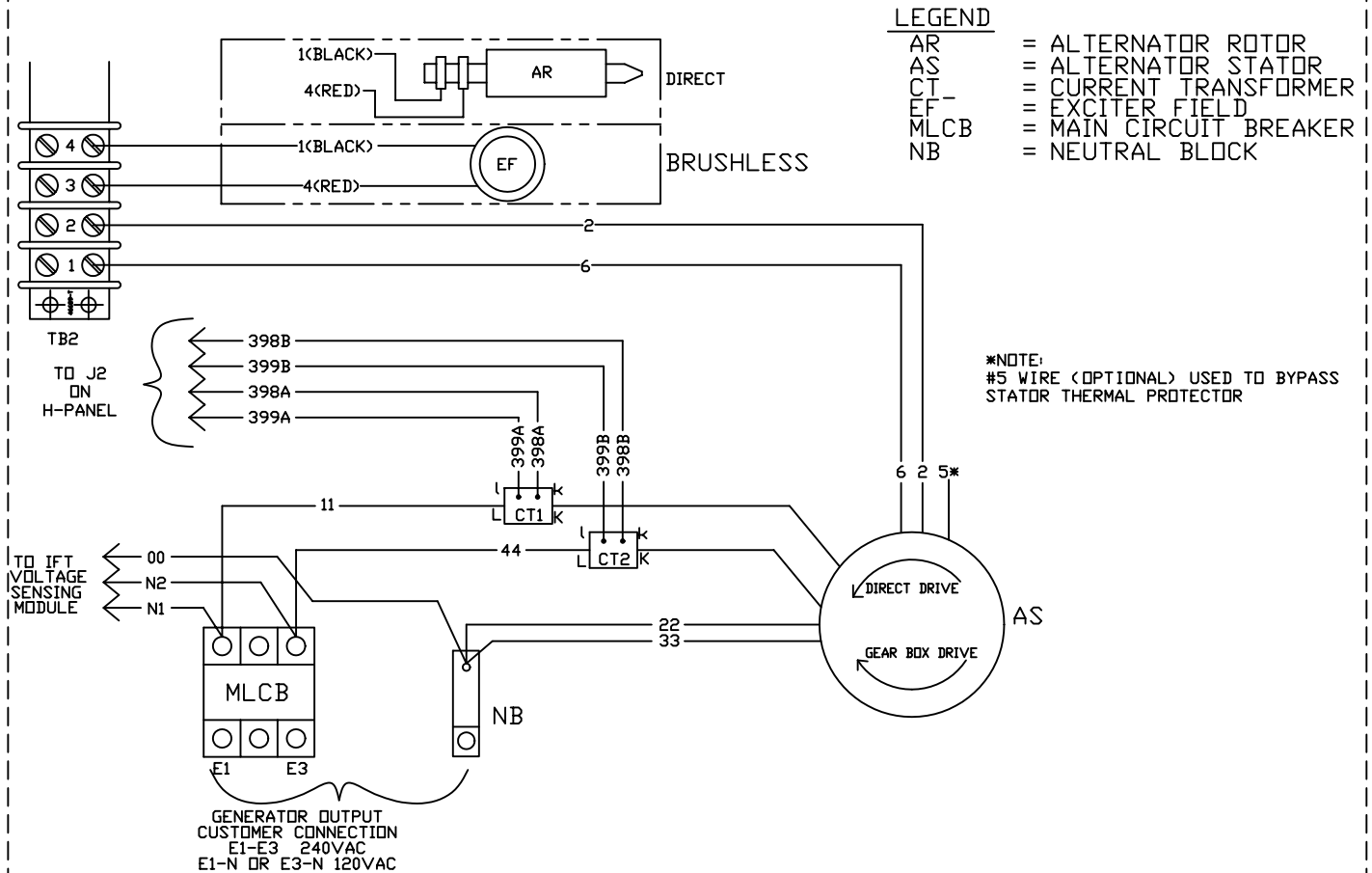

OPTION 2 - THREE PHASE, H-100 CONTROL PANEL DIRECT DRIVE, 6 LEAD

LEGEND

- AR = ALTERNATOR ROTOR
- AS = ALTERNATOR STATOR
- CT = CURRENT TRANSFORMER
- EF = EXCITER FIELD
- MLCB = MAIN CIRCUIT BREAKER
- NB = NEUTRAL BLOCK

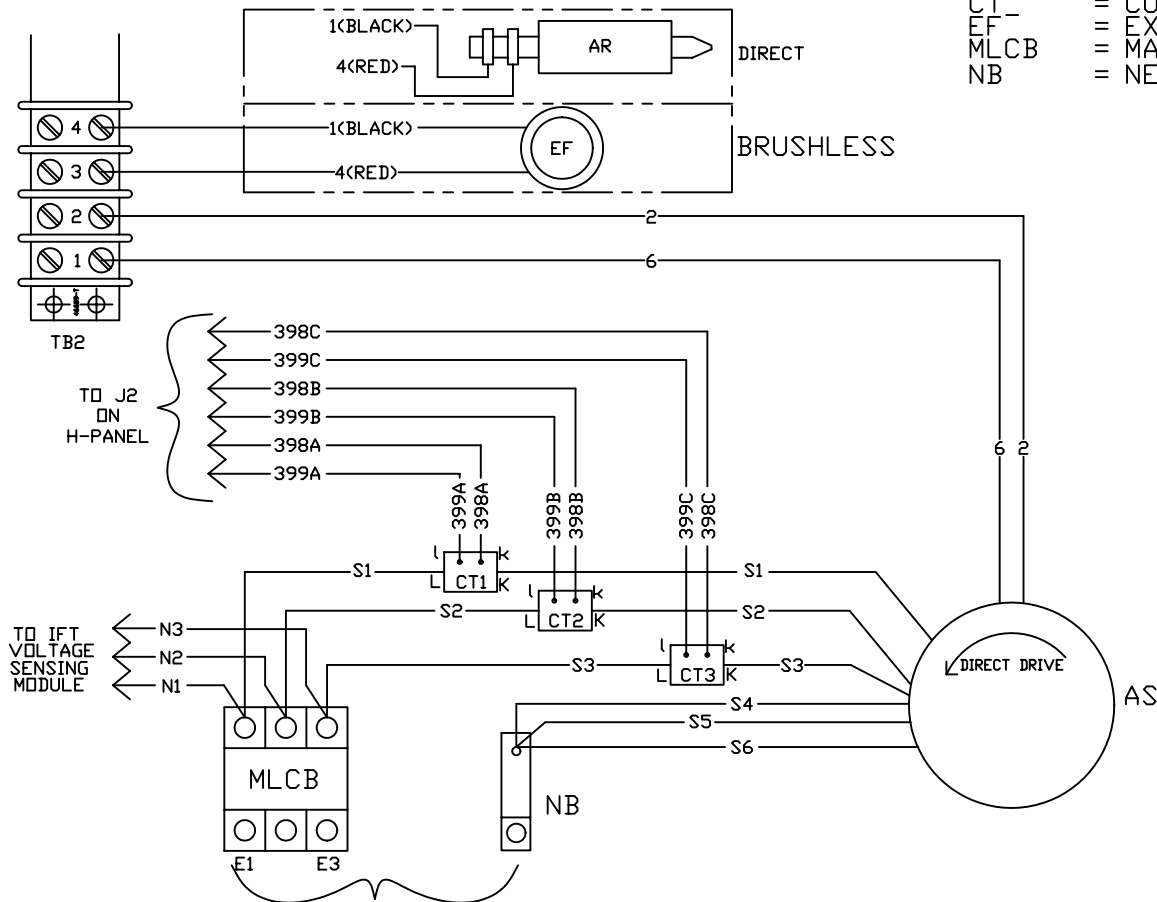

GENERATOR OUTPUT CUSTOMER CONNECTION

E1 TO E2 } \*208 OR 480VAC  
 E2 TO E3 }  
 E1 TO E3 }

E1, E2, OR E3 TO NB = \* 120 OR 277VAC

\*NOTE: THE 8th DIGIT OF THE MODEL NUMBER SPECIFIES OUTPUT VOLTAGE

\*G = 120/208VAC  
 \*K = 277/480VAC

## OPTION 3 - THREE PHASE, H-100 CONTROL PANEL GEAR BOX (REVERSE ROTATION)

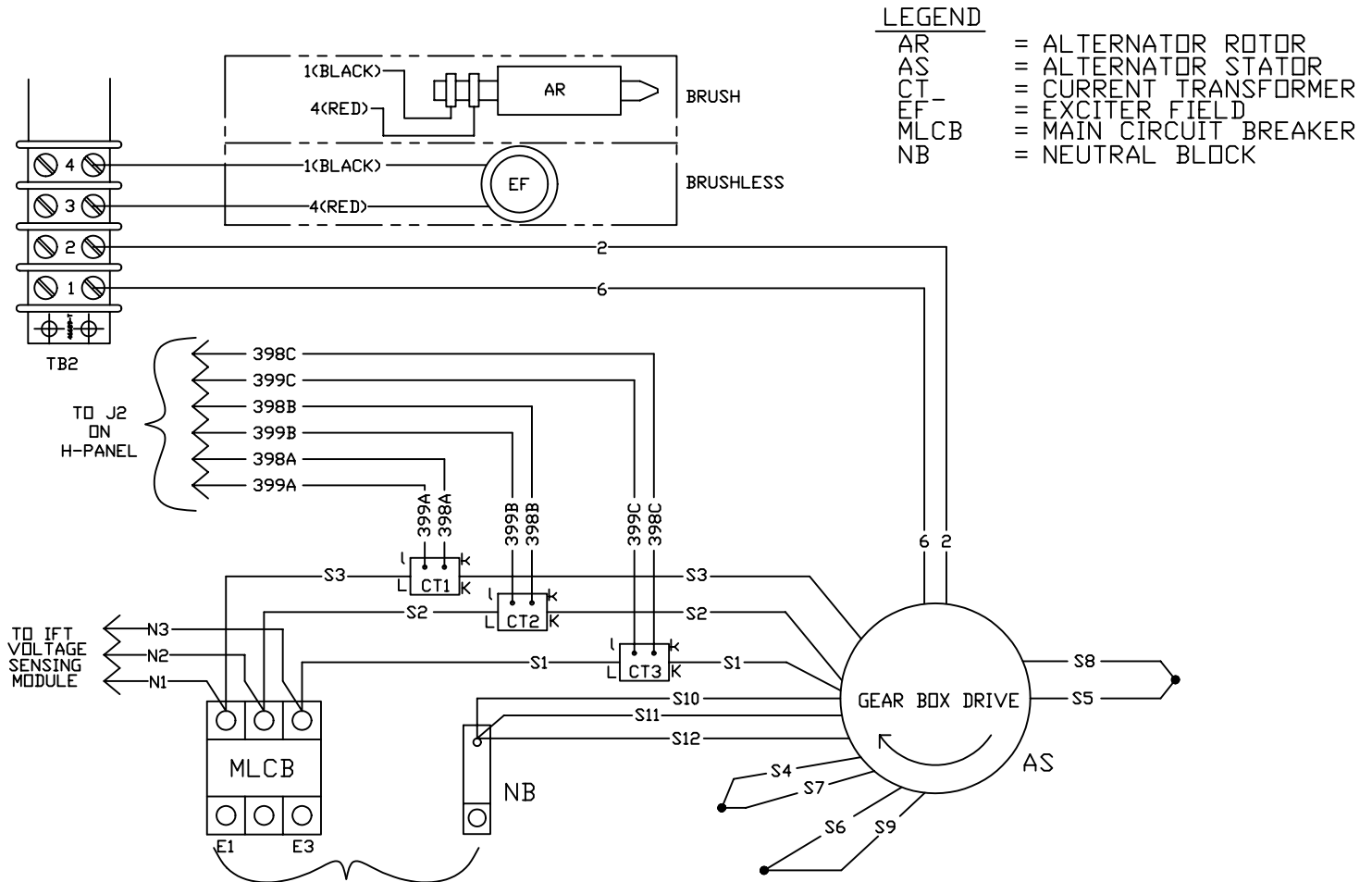

### LEGEND

- AR = ALTERNATOR ROTOR
- AS = ALTERNATOR STATOR
- CT = CURRENT TRANSFORMER
- EF = EXCITER FIELD
- MLCB = MAIN CIRCUIT BREAKER
- NB = NEUTRAL BLOCK

GENERATOR OUTPUT  
CUSTOMER CONNECTION  
E1 TO E2 }  
E2 TO E3 } \*208 OR 480VAC  
E1 TO E3 }  
E1, E2, OR E3 TO NB = \* 120 OR 277VAC  
\*NOTE: THE 8<sup>th</sup> DIGIT OF THE MODEL NUMBER SPECIFIES OUTPUT VOLTAGE  
\*G\* = 120/208VAC  
\*K\* = 277/480VAC

## OPTION 4 - THREE PHASE DELTA, H-100 CONTROL PANEL DIRECT DRIVE, 7 LEAD

### LEGEND

- AR = ALTERNATOR ROTOR
- AS = ALTERNATOR STATOR
- CT = CURRENT TRANSFORMER
- EF = EXCITER FIELD
- MLCB = MAIN CIRCUIT BREAKER
- NB = NEUTRAL BLOCK

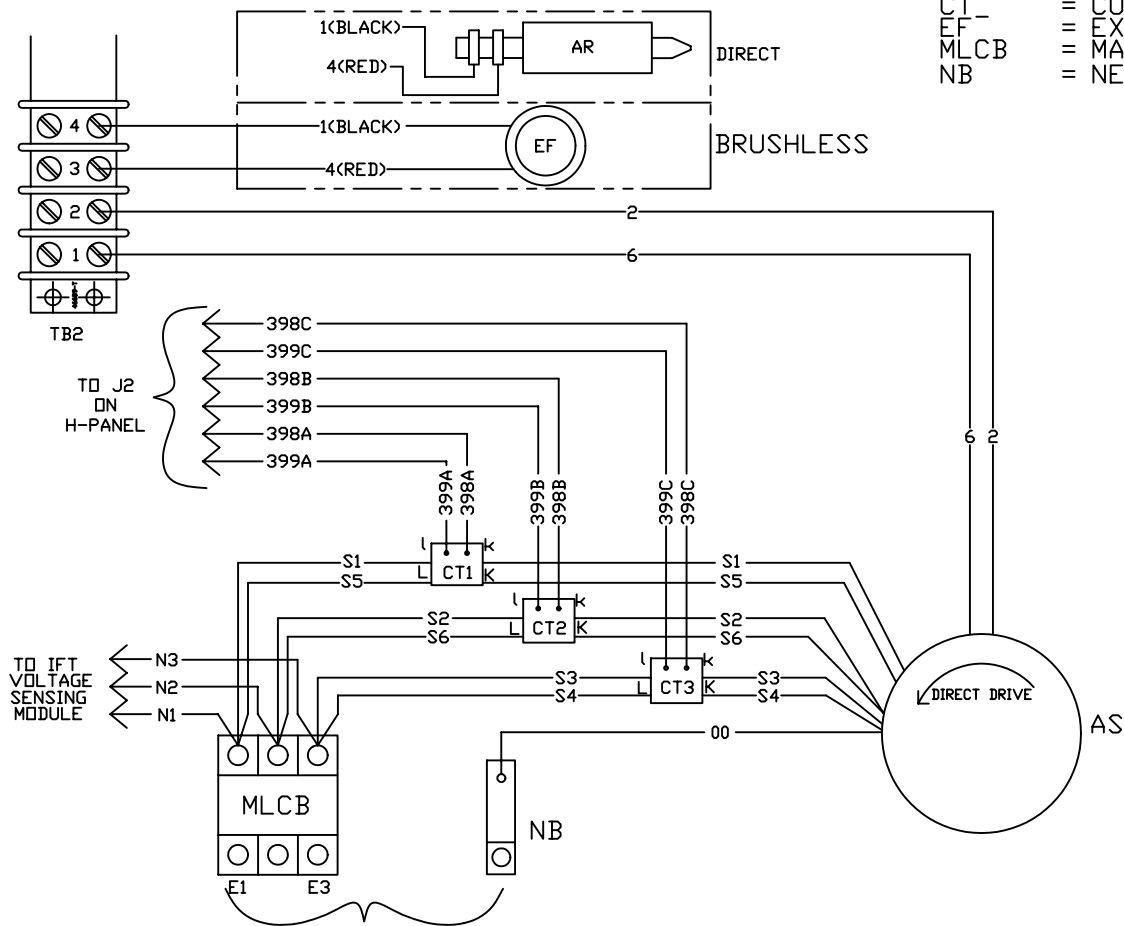

GENERATOR OUTPUT  
CUSTOMER CONNECTION  
E1 TO E2 } 240VAC  
E2 TO E3 }  
E1 TO E3 }

E1-N OR E3-N = 120VAC

\*NOTE: THE 8th DIGIT OF THE MODEL NUMBER SPECIFIES OUTPUT VOLTAGE  
\*J\* = 120/240VAC



## Standby Generator Sets Warranty



### GENERAC POWER SYSTEMS STANDARD LIMITED WARRANTY FOR COMMERCIAL PRODUCT 50kW AND ABOVE

For a period of two (2) years from the date of sale, or start-up by Authorized/Certified Generac Power Systems Dealer, or branch thereof, Generac Power Systems, Inc. will, at its option, repair or replace any part(s) which, upon examination, inspection, and testing by Generac Power Systems or an Authorized/Certified Generac Power Systems Dealer, or branch thereof, is found to be defective under normal use and service, in accordance with the warranty schedule set forth below. Any equipment that the purchaser/owner claims to be defective must be examined by the nearest Authorized/Certified Generac Power Systems Dealer, or branch thereof. This warranty applies only to Generac Power Systems Generators used in "Standby" applications, as Generac Power Systems, Inc. has defined Standby, provided said generator has been properly installed and inspected on-site by appropriate personnel. Scheduled maintenance, as outlined by the generator owner's manual, is highly recommended. This should be performed by an Authorized/ Certified Generac Power Systems Dealer, or branch thereof. This will verify service has been performed on the unit throughout the warranty period.

#### WARRANTY SCHEDULE

**YEAR ONE** — Limited comprehensive coverage on mileage, labor, and parts listed.

- - ALL COMPONENTS

**YEAR TWO** — Limited comprehensive coverage on parts listed.

- - ALL COMPONENTS

\*Start-up and/or On-line Registration, or Registration Card, along with Proof of Purchase, must be performed and/or sent in.

#### Guidelines:

- Any and all warranty repairs and/or concerns, must be performed and/or addressed by an Authorized/Certified Generac Power Systems Dealer, or branch thereof.
- A Generac Power Systems, Inc. Transfer Switch is highly recommended to be used in conjunction with the genset. If a Non - Generac Power Systems, Inc. Transfer Switch is substituted for use and directly causes damage to the genset, no warranty coverage shall apply.
- All warranty expense allowances are subject to the conditions defined in Generac Power Systems Warranty, Policies, and Procedures Flat Rate Manual.
- Units that have been resold are not covered under the Generac Power Systems Warranty, as this Warranty is not transferable.
- Unit enclosure is only covered against rust or corrosion the first year of the warranty provision.
- Use of Non-Generac replacement part(s) will void the warranty in its entirety.
- Engine coolant heaters (block-heaters), heater controls and circulating pumps are only covered during the first year of the warranty provision (If applicable).

#### THIS WARRANTY SHALL NOT APPLY TO THE FOLLOWING:

1. Any unit built/manufactured prior to March 1, 2005.
2. Costs of normal maintenance (i.e. tune-ups, associated part(s), adjustments, loose/leaking clamps, installation and start-up).
3. Any failure caused by contaminated fuels, oils, coolants/antifreeze or lack of proper fuels, oils or coolants/antifreeze.
4. Units sold, rated or used for "Prime Power", "Trailer Mounted" or "Rental Unit" applications as Generac Power Systems have defined Prime Power, Trailer Mounted or Rental Unit. Contact a Generac Power Systems Distributor for Prime Power, Trailer Mounted or Rental Unit definition and warranty.
5. Units used for prime power in place of existing utility power where utility is present or in place of utility power where utility power service does not normally exist.
6. Failures caused by any external cause or act of God such as, but not limited to, collision, fire, theft, freezing, vandalism, riot or wars, lightning, earthquake, windstorm, hail, volcanic eruption, water or flood, tornado, hurricane, terrorist acts or nuclear holocaust.
7. Products that are modified or altered in a manner not authorized by Generac Power Systems in writing.
8. Failures due, but not limited to, normal wear and tear, accident, misuse, abuse, negligence, or improper installation or sizing.
9. Any incidental, consequential or indirect damages caused by defects in materials or workmanship, or any delay in repair or replacement of the defective part(s).
10. Failure due to misapplication, misrepresentation, or bi-fuel conversion.
11. Telephone, facsimile, cell phone, satellite, internet, or any other communication expenses.
12. Rental equipment used while warranty repairs are being performed (i.e. rental generators, cranes, etc.).
13. Overtime, holiday, or emergency labor.
14. Planes, ferries, railroad, busses, helicopters, snowmobiles, snow-cats, off-road vehicle or any other mode of transportation deemed abnormal.
15. Any and all expenses incurred investigating performance complaints unless defective Generac materials and/or workmanship were the direct cause of the problem.
16. Starting batteries, fuses, light bulbs, engine fluids, and overnight freight cost for replacement part(s).

THIS WARRANTY IS IN PLACE OF ALL OTHER WARRANTIES, EXPRESSED OR IMPLIED, SPECIFICALLY, GENERAC POWER SYSTEMS MAKES NO OTHER WARRANTIES AS TO THE MERCHANTABILITY OR FITNESS FOR A PARTICULAR PURPOSE. Some states do not allow limitations on how long an implied warranty lasts, so the above limitation may not apply to purchaser/owner.

GENERAC POWER SYSTEMS ONLY LIABILITY SHALL BE THE REPAIR OR REPLACEMENT OF PART(S) AS STATED ABOVE. IN NO EVENT SHALL GENERAC POWER SYSTEMS BE LIABLE FOR ANY INCIDENTAL, OR CONSEQUENTIAL DAMAGES, EVEN IF SUCH DAMAGES ARE A DIRECT RESULT OF GENERAC POWER SYSTEMS, INC. NEGLIGENCE.

Some states do not allow the exclusion or limitation of incidental or consequential damages, so the above limitations may not apply to purchaser/owner. Purchaser/owner agrees to make no claims against Generac Power Systems, Inc. based on negligence. This warranty gives purchaser/owner specific legal rights. Purchaser/owner also may have other rights that vary from state to state

**Generac Power Systems, Inc. · P.O. Box 8 · Waukesha, WI 53187**  
**Ph: (262) 544-4811 · Fax: (262) 544-4851**

Bulletin 0171370SVE / Printed in U.S.A. 7.05