

SHIMANO 105 Front Derailleur for Triple Gear

FD-5703-S Silver Version

FD-5703-L Black Version

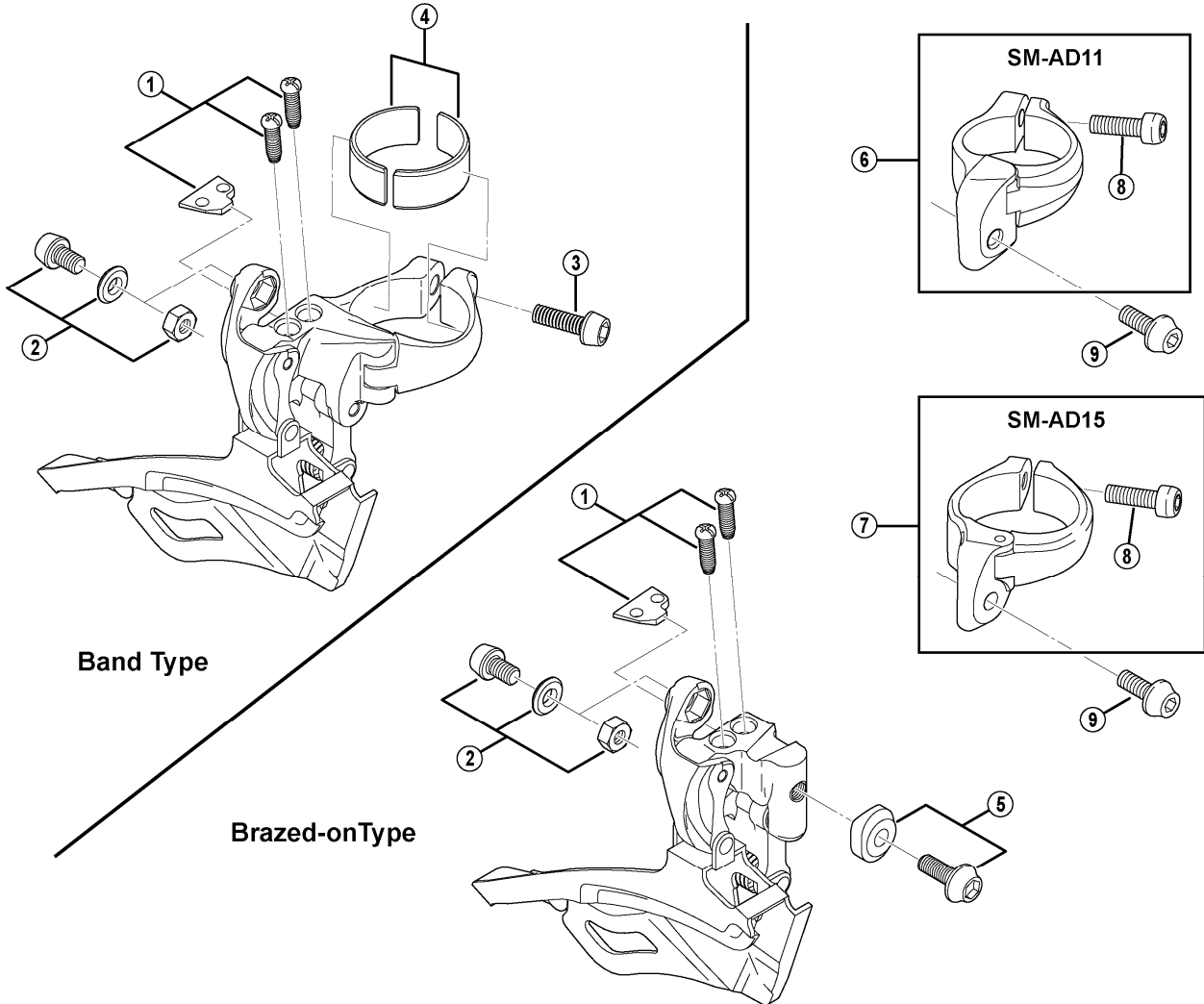

FD-6703

FD-5603

| ITEM NO. | SHIMANO CODE NO. | DESCRIPTION | INTERCHANGEABILITY | | |
|----------|------------------|--|--------------------|---|--|
| 1 | Y5MR98010 | Stroke Adjust Screws (M4 x 13) & Plate | | | |
| * 2 | Y5MR98020 | Cable Fixing Bolt Unit (M5 x 8) | | | |
| 3 | Y5A407020 | Clamp Bolt (M5 x 15) | A | A | |
| 4 | Y5JD98020 | Clamp Band Adapter (2 pcs.) for S-size / ϕ 28.6 mm (1-1/8") | A | A | |
| 5 | Y5JD98030 | Clamp Bolt (M5 x 13.5) & Radius Washer for Brazed-on Type | A | | |
| 6 | Y5JD98040 | SM-AD11 Clamp Band Unit ϕ 31.8 mm (1-1/4") for Brazed-on Type | A | | |
| 7 | Y5JD98050 | SM-AD15 Clamp Band Unit ϕ 34.9 mm (1-3/8") for Brazed-on Type | A | | |
| 8 | Y59L19100 | Clamp Bolt (M5 x 17.5) for SM-AD11 / AD15 | A | | |
| 9 | Y5C252000 | Clamp Bolt (M5 x 13.5) for SM-AD11 / AD15 | A | A | |

A: Same parts.

B: Parts are usable, but differ in materials, appearance, finish, size, etc.

Absence of mark indicates non-interchangeability.

Sep.-2012-3053A

© Shimano Inc. A

Specifications are subject to change without notice.

SHIMANO

General Safety Information

WARNING

- Obtain and read the service instructions carefully prior to installing the parts. Loose, worn or damaged parts may cause the bicycle to fall over and serious injury may occur as a result. We strongly recommend only using genuine Shimano replacement parts.
- Obtain and read the service instructions carefully prior to installing the parts. If adjustments are not carried out correctly, the chain may come off and this may cause you to fall off the bicycle which could result in serious injury.
- Be careful not to let the cuffs of your clothes get caught in the chain while riding, otherwise you may fall off the bicycle.
- Read these Technical Service Instructions carefully, and keep them in a safe place for later reference.

Note

- If gear shifting operations cannot be carried out smoothly, clean the derailleur and lubricate all moving parts.
- If the amount of looseness in the links is so great that adjustment is not possible, you should replace the derailleur.
- Use the CN-7801 / CN-6600 / CN-5600 with the FD-6703 / FD-5703.
- When the chain is in the position shown in the illustration, the chain may contact the front chainrings or front derailleur and generate noise. If the noise is a problem, shift the chain onto the next-larger rear sprocket or the one after.

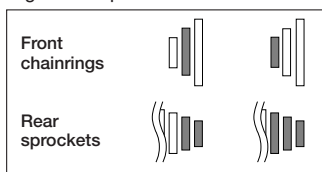

- For smooth operation, use the specified outer casing and the bottom bracket cable guide.
- Grease the inner cable and the inside of the outer casing before use to ensure that they slide properly.
- This front derailleur is for triple front chainwheel use only. It cannot be used with the double front chainwheel, as the shifting points do not match.
- Parts are not guaranteed against natural wear or deterioration resulting from normal use.
- For maximum performance we highly recommend Shimano lubricants and maintenance products.
- For any questions regarding methods of installation, adjustment, maintenance or operation, please contact a professional bicycle dealer.

Technical Service Instructions

SI-5LX0B-001

FD-6703 / FD-5703

Front derailleur

SHIMANO

SHIMANO AMERICAN CORPORATION
One Holland, Irvine, California 92618, U.S.A. Phone: +1-949-951-5003

SHIMANO EUROPE B.V.
Industrieweg 24, 8071 CT Nunspeet, The Netherlands Phone: +31-341-272222

SHIMANO INC.
3-77 Oimatsu-cho, Sakai-ku, Sakai-shi, Osaka 590-8577, Japan

* Service Instructions in further languages are available at : <http://techdocs.shimano.com>

Please note: specifications are subject to change for improvement without notice. (English)
© Dec. 2009 by Shimano Inc. XBC SZK Printed in Japan.

In order to realize the best performance, we recommend that the following combination be used.

| | | |
|----------------------------|-----------------------------|---------|
| Series | ULTEGRA | 105 |
| Shifting lever | ST-6703 | ST-5703 |
| Outer casing | SP41 | SP41 |
| Gears | 30 | 30 |
| Front derailleur | FD-6703 | FD-5703 |
| Front chainwheel | FC-6703 | FC-5703 |
| Rear derailleur | RD-6700 | RD-5700 |
| Freehub | FH-6700 | FH-5700 |
| Cassette sprocket | CS-6700 | CS-5700 |
| Chain | CN-7801 / CN-6600 / CN-5600 | |
| Bottom bracket cable guide | SM-SP17 | SM-SP17 |

Specifications

| | | |
|--|---------------------------------------|------------------|
| Series | ULTEGRA | 105 |
| Type | Band type / Brazed on type | |
| Front chainwheel tooth difference | 22 teeth or less | 20 teeth or less |
| Min. difference between top and intermediate | 13T | 11T |
| Front derailleur installation band diameter | S (ø28.6mm), M (ø31.8mm), L (ø34.9mm) | |
| Chainstay angle (α) | 63° - 66° | |
| Chain line | 45mm | |

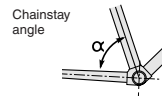

Front shifting

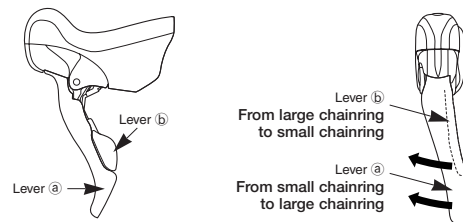

Installation of the front derailleur

Adjust and then install the front derailleur as shown in the illustration. Do not remove the Pro-Set alignment block at this time.

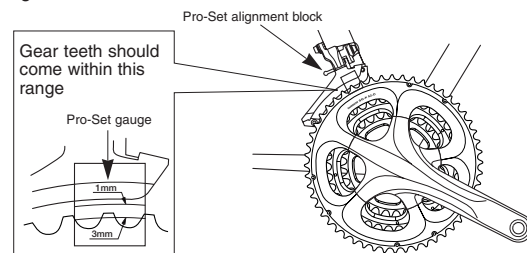

The level section of the chain guide outer plate should be directly above and parallel to the largest chainring. Secure using a 5mm Allen key.

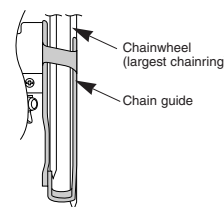

Tightening torque:
5 - 7 N·m {44 - 60 in. lbs.}

In the case of carbon frames, it may be necessary to lower the tightening torque in order to prevent damage to the frame. Please consult the bicycle or frame manufacturer regarding the appropriate level of tightening torque for carbon frames.

SIS adjustment

Be sure to follow the sequence described below.

1. Low adjustment

First remove the Pro-Set alignment block. Next, set so that the clearance between the chain guide inner plate and the chain is 0 - 0.5mm.

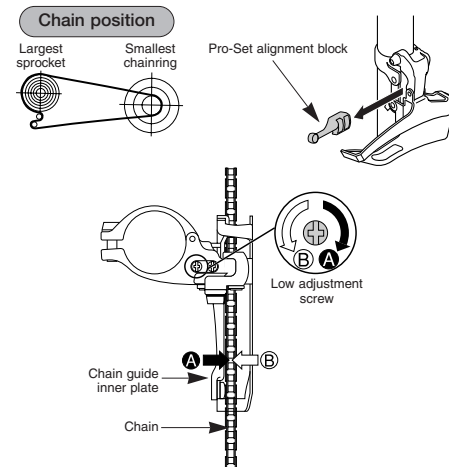

2. Connection and securing of cable

While pulling the inner cable, tighten the wire fixing bolt with a 5 mm allen key to secure the cable.

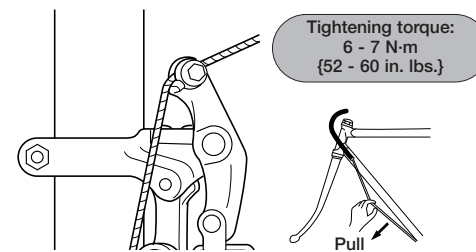

After taking up the initial slack in the cable, re-secure to the front derailleur as shown in the illustration.

3. Top adjustment

Set so that the clearance between the chain guide outer plate and the chain is 0 - 0.5 mm.

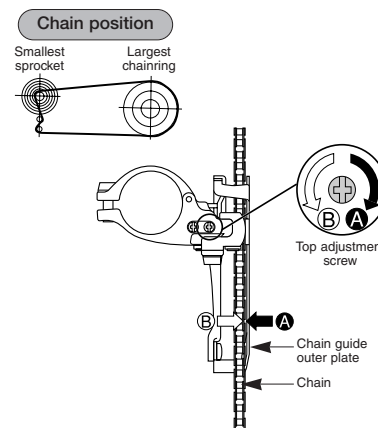

4. Cable adjustment using the intermediate chaining

When making the cable adjustment, place the chain on the largest sprocket for the rear and the middle chainring for the front.

Note: There are 2 derailleur positions for the intermediate chaining. When making the cable adjustment, make sure that the derailleur is in the inner side (toward small chainring) of the two positions. Locate the derailleur to this position by shifting from the largest to the intermediate chainring (recommended) or by shifting from the small to the intermediate chainring, then gently press lever (b) until a small click is felt (to position the derailleur to the inner side of the intermediate chainring).

Adjust the cable tension by using the outer adjustment barrel so that the clearance between the chain guide inner plate and the chain is 0 - 0.5 mm.

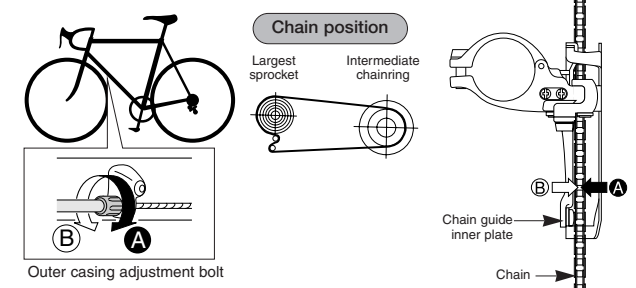

5. Trimming mechanism adjustment and checking

While turning the crank arm, gently operate lever (b) and check that the front derailleur moves slightly toward the smallest chainring. If the front derailleur moves by a large amount and the chain is set onto the smallest chainring at this time, loosen the top adjustment bolt by 1/8th of a turn. Then, after returning the chain to its original position, adjust and check the trimming mechanism.

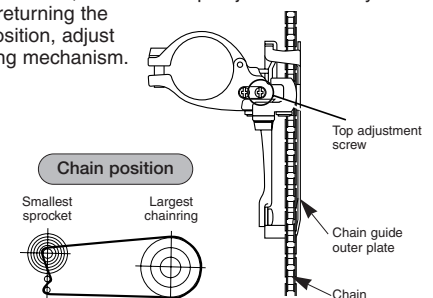

6. Troubleshooting chart

After completion of steps 1 - 5, move the shifting lever to check the shifting. (This also applies if shifting becomes difficult during use.)

| | |
|--|--|
| If the chain falls to the crank side | Tighten the top adjustment screw clockwise (about 1/4 turn). |
| If shifting is difficult from the intermediate chainring to the largest chainring | Loosen the top adjustment screw counterclockwise (about 1/8 turn). |
| If shifting is difficult from the intermediate chainring to the smallest chainring | Loosen the low adjustment screw counterclockwise (about 1/4 turn). |
| If there is interference between the chain and the front derailleur outer plate at the largest chainring | Loosen the top adjustment screw counterclockwise (about 1/8 turn). |
| If the intermediate chainring is skipped when shifting from the largest chainring | Loosen the outer casing adjustment bolt counterclockwise (1 or 2 turns). |
| If there is interference between the chain and front derailleur inner plate when the rear sprocket is shifted to the largest sprocket when the chainwheel is at the intermediate chainring position. | Tighten the outer casing adjustment bolt clockwise (1 or 2 turns). |
| If the chain falls to the bottom bracket side. | Tighten the low adjustment screw clockwise (about 1/2 turn). |

Be sure to read these service instructions in conjunction with the service instructions for the ST-6703 / ST-5703 before use.