

Robin Industrial Engines®

SERVICE MANUAL

Model

EY21

1193S105



ROBIN AMERICA, INC.
ROBIN TO WISCONSIN ROBIN
ENGINE MODEL CROSS REFERENCE LIST

ROBIN

WISCONSIN ROBIN

SIDE VALVE

EY08	W1-080
EY15	W1-145
EY15V	W1-145V
EY20	W1-185
EY20V	W1-185V
EY23	W1-230
EY28	W1-280
EY35	W1-340
EY40	W1-390
EY45V	W1-450V
EY21	EY21W
EY44	EY44W
EY18-3	EY18-3W
EY25	EY25W
EY27	EY27W

OVERHEAD VALVE

EH11	WO1-115
EH12	WO1-120
EH15	WO1-150
EH17	WO1-170
EH21	WO1-210
EH25	WO1-250
EH30	WO1-300
EH30V	WO1-300V
EH34	WO1-340
EH34V	WO1-340V
EH43V	WO1-430V

TWO CYCLE

EC13V	WT1-125V
-------	----------

DIESEL

DY23	WRD1-230
DY27	WRD1-270
DY30	WRD1-300
DY35	WRD1-350
DY41	WRD1-410

CONTENTS

<i>Section</i>	<i>Title</i>	<i>Page</i>
1.	SPECIFICATIONS	1
2.	PERFORMANCE	2
2-1.	Maximum Output	2
2-2.	Continuous Rated Output	2
2-3.	Torque and Fuel Consumption Ratio at Max. Output	2
3.	FEATURES	3
4.	GENERAL DESCRIPTION OF ENGINE CONSTRUCTION	4
4-1.	Sectional View of Engine	4
4-2.	Crankcase	6
4-3.	Cylinder and Cylinder Head	6
4-4.	Crankshaft	6
4-5.	Connecting Rod and Piston	6
4-6.	Camshaft	6
4-7.	Governor	6
4-8.	Cooling	6
4-9.	Lubrication	7
4-10.	Carburetor	8
4-11.	Air Cleaner	8
4-12.	Ignition	8
4-13.	Selenium Rectifier	8
4-14.	Clutch	8
4-15.	Reducer	8
5.	INSTALLATION	9
5-1.	Installing	9
5-2.	Ventilation	9
5-3.	Exhaust Gas Evacuation	9
5-4.	Fuel System	9
5-5.	Control Box and Remote Control	10
5-6.	Power Transmission to Driven Machines	10
5-7.	Wiring	11
6.	DISASSEMBLY AND REASSEMBLY	14
6-1.	Preparations and Suggestions	14
6-2.	Standard Tools	15
6-3.	Special Tools	15
6-4.	Disassembly and Reassembly Procedures	16
6-5.	Clutch Device	26
6-6.	Reduction Device	27
6-7.	Clutch and Reduction Device	27

7. ELECTRICAL EQUIPMENT	28
7-1. AC Alternator (for Model EY21AS)	28
7-2. Starting Motor (for Model EY21AS)	29
7-3. Magneto (for Model EY21B)	30
7-4. Breaker Point Adjustment	30
7-5. Timing Adjustment	31
7-6. Spark Testing	32
7-7. Battery (for Model EY21AS)	32
8. GOVERNOR	34
8-1. Governor Linkage	34
8-2. Governor Adjustment	34
9. CARBURETOR	36
9-1. Operation and Construction	36
9-2. Disassembly and Reassembly	37
9-3. Adjustments	39
10. RUN-IN OPERATION OF REASSEMBLED ENGINE	40
11. TROUBLE SHOOTING	41
11-1. Starting Difficulties	41
11-2. Idling Out of Order	43
11-3. Overheat and Knocking	43
11-4. Engine Power Lost	44
11-5. Excessive Fuel Consumption	44
11-6. Excessive Oil Consumption	44
11-7. Engine Hunting	44
11-8. Clutch and Reducer Out of Order	45
11-9. Other Complaints	45
12. CHECKS AND CORRECTIONS	46
13. MAINTENANCE AND STORING	50
13-1. Daily Checks and Maintenance	50
13-2. Every 50 Hours (10 Days) Checks and Maintenance	50
13-3. Every 100~200 Hours (Monthly) Checks and Maintenance	50
13-4. Every 300~600 Hours Checks and Maintenance	51
13-5. Every 700~1000 Hours Checks and Maintenance	51
13-6. Preparation for Long Abeyance	51

1. SPECIFICATIONS

Model	EY21AS				EY21B				
	-C	-R	-CR		-C	-R	-CR		
Type	Air-Cooled, 4-Cycle, Opposed Twin-Cylinder, Horizontal P.T.O. shaft								
Bore x Stroke (in)	2 – 75mm x 70mm (2 – 2.95 x 2.76)								
Piston Displacement (cu.in)	618 cc (37.74)								
Compression Ratio	6.0								
Output	Continuous	10 HP/3,000 r.p.m.	10 HP/1,500 r.p.m.		10 HP/3,000 r.p.m.	10 HP/1,500 r.p.m.			
	Max.	16 HP/3,600 r.p.m.	16 HP/1,800 r.p.m.		16 HP/3,600 r.p.m.	16 HP/1,800 r.p.m.			
Maximum Torque	3.5 kg-m/2,600 r.p.m.		7 kg-m/1,300 r.p.m.		3.5 kg-m/2,600 r.p.m.		7 kg-m/1,300 r.p.m.		
Direction of Rotation	Counter clockwise as viewed from driving shaft side								
Valve Arrangement	Side-Valve Type								
Cooling System	Forced Air-Cooling								
Lubrication	Splashing Type								
Lubricant	Mobile Oil SAE #30								
Lubricating Pump	Trochoid Gear Pump Type								
Carburetor	Down Draft Type								
Fuel	Automobile Gasoline								
Fuel Feed	Diaphragm Pump Type								
Fuel Tank Capacity (U.S.gal.)	Approx. 13 liters (3.43 U.S.gal.)								
Fuel Consumption Ratio	270 g/HP-h at 10 HP/3,000 r.p.m.		270 g/HP-h at 10 HP/1,500 r.p.m.		270 g/HP-h at 10 HP/3,000 r.p.m.		270 g/HP-h at 10 HP/1,500 r.p.m.		
Reduction Ratio	—		1/2 Chain Reduction		—		1/2 Chain Reduction		
Governor	Centrifugal Flyweight Type								
Clutch	—	Dry Single Plate Type	—	Dry Single Plate Type	—	Dry Single Plate Type	—	Dry Single Plate Type	
Method of Ignition	Battery				Magnetogenerator				
Spark Plug	N G K B-4H		N G K B-4		N G K B-4H		N G K B-4		
Lighting Capacity	12V ~ 16V, 35W				12V ~ 16V, 25W				
Starting System	Electric Starter				Rope Type				
Dry Weight (lbs)	73 kg (161)	82 kg (181)	81 kg (179)	89 kg (197)	67 kg (148)	76 kg (168)	75 kg (166)	83 kg (183)	
Dimensions	L (in)	569 mm (22.40)	685 mm (26.97)	689 mm (27.97)	763 mm (30.04)	569 mm (22.40)	685 mm (26.97)	689 mm (27.13)	763 mm (30.04)
	W x H (in)	625 mm x 556 mm (24.61 x 21.89)							

2. PERFORMANCE

2-1 MAXIMUM OUTPUT

The maximum output of an engine is such a standard power as developed by that engine, with all the moving parts properly worn-in, after its initial run-in period, when operating with the throttle valve fully open.

Therefore it follows that a new engine may not develop this maximum output in the beginning, because moving parts are not in a properly worn-in condition.

2-2 CONTINUOUS RATED OUTPUT

The continuous rated output of an engine is such a power as developed by that engine when running at an optimum speed most favorable from the point of view of engine life and fuel consumption ratio. Therefore, it follows that when designing a driving system for any mechanism, with a Model EY21 engine as the prime mover, the continuous power requirement of that mechanism must be kept below the specified continuous rated output.

2-3 MAXIMUM TORQUE AND FUEL CONSUMPTION RATIO AT MAX. OUTPUT

The maximum torque of an engine is that torque of the driving shaft at which engine drives an external load, while the engine is developing its max. output. The specific fuel consumption at max. output is that fuel consumption which an engine developing its max. output consumes in a unit time.

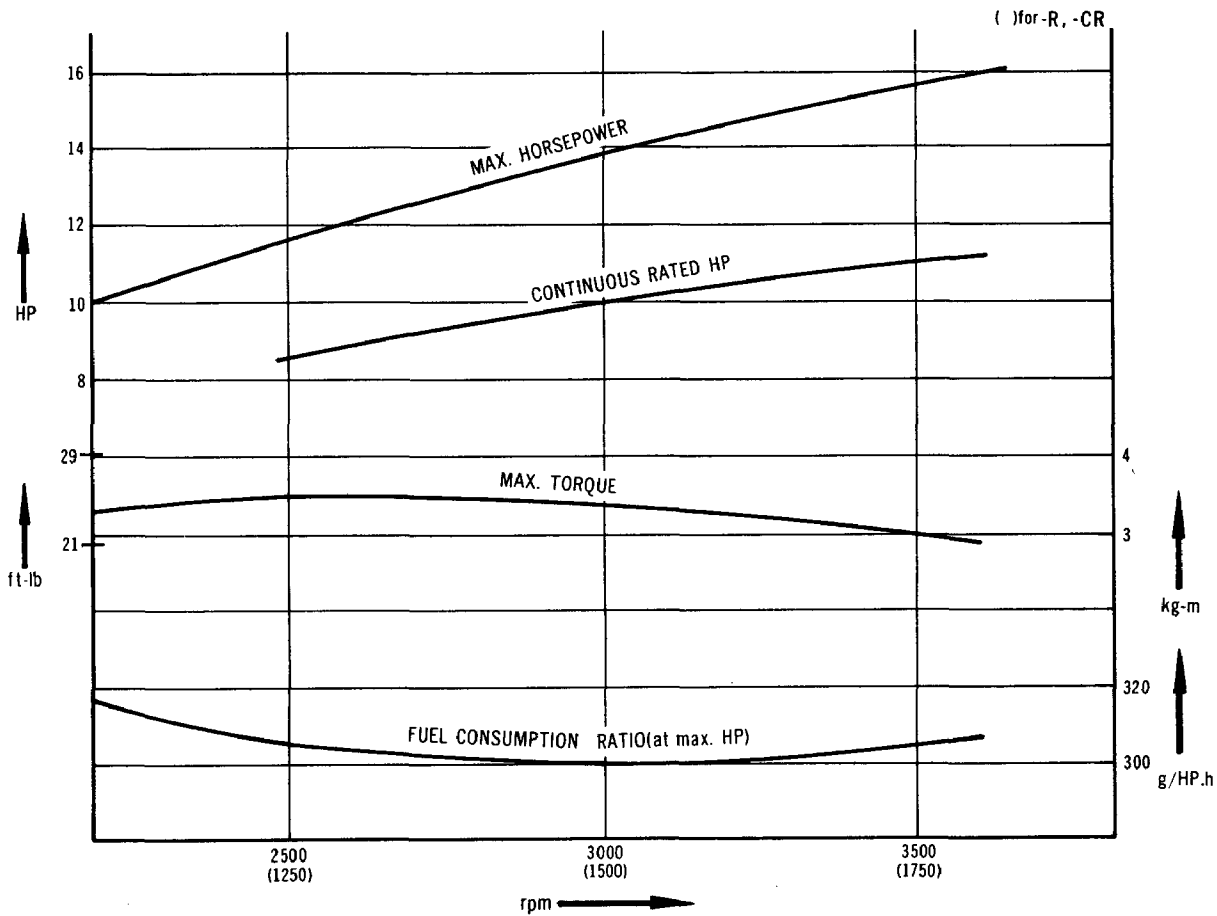

3. FEATURES

- 1) Compact, lightweight and easily transportable
Low noise attained by horizontal opposed cylinder arrangement.
The lightest engine in the 10 HP class, weighing only 67kg, which is 1/3 the weight of a conventional water-cooled kerosine engine of an equivalent output.
- 2) Low fuel consumption
Specific fuel consumption of conventional engine: 280~310g/HP/hr
Specific fuel consumption of EY21 engine: 270g/HR/hr
- 3) High-Performance engine at comparative low price
Produced in an advanced plant utilizing superior engineering technique, the cost of this high-performance engine is maintained low.
- 4) Multi-purpose type engine with wide range of applications
Starting System: Starting motor (Model EY21AS)
Rope starting (Model EY21B)
Power Transmission: with clutch (Models EY21AS-C, EY21B-C)
with reducer (Models EY21AS-R, EY21B-R)
with clutch and reducer (Models EY21AS-CR, EY21B-CR)
- 5) Trouble-free operation and easy maintenance
Because the design is simple, trouble possibility is reduced to a minimum.
- 6) Durable engine offering a long service life
The long service life is guaranteed by the ingenious design, high-quality materials, precision machining, and thorough quality control.
- 7) Minimum vibration
The horizontal opposed cylinder arrangement is advantageous for vibration elimination, more than any other designs, such as single cylinder, inline, and two-cylinder V arrangement.
- 8) The engine speed controlled at will with a all-speed governor.
The engine can be set for any desired speed by simply moving the governor lever.
The set speed is maintained even under a varying load.
- 9) The fuel tank set at any convenient position thanks to a fuel pump.
The fuel tank may be set below the carburetor within approx. 80cm
- 10) For night operation, lighting is available.
Lighting power: EY21AS—12V, 35W
EY21B—12V, 25W

4. GENERAL DESCRIPTION OF ENGINE CONSTRUCTION

The Model EY21 engine is a Forced Air-Cooled, 4-Cycle, Opposed, Twin-Cylinder, Side-Valve engine. As viewed from the blower side, the left side is designated as No. 1 side and the right side is designated as No. 2 side.

4-1 SECTIONAL VIEW OF ENGINE

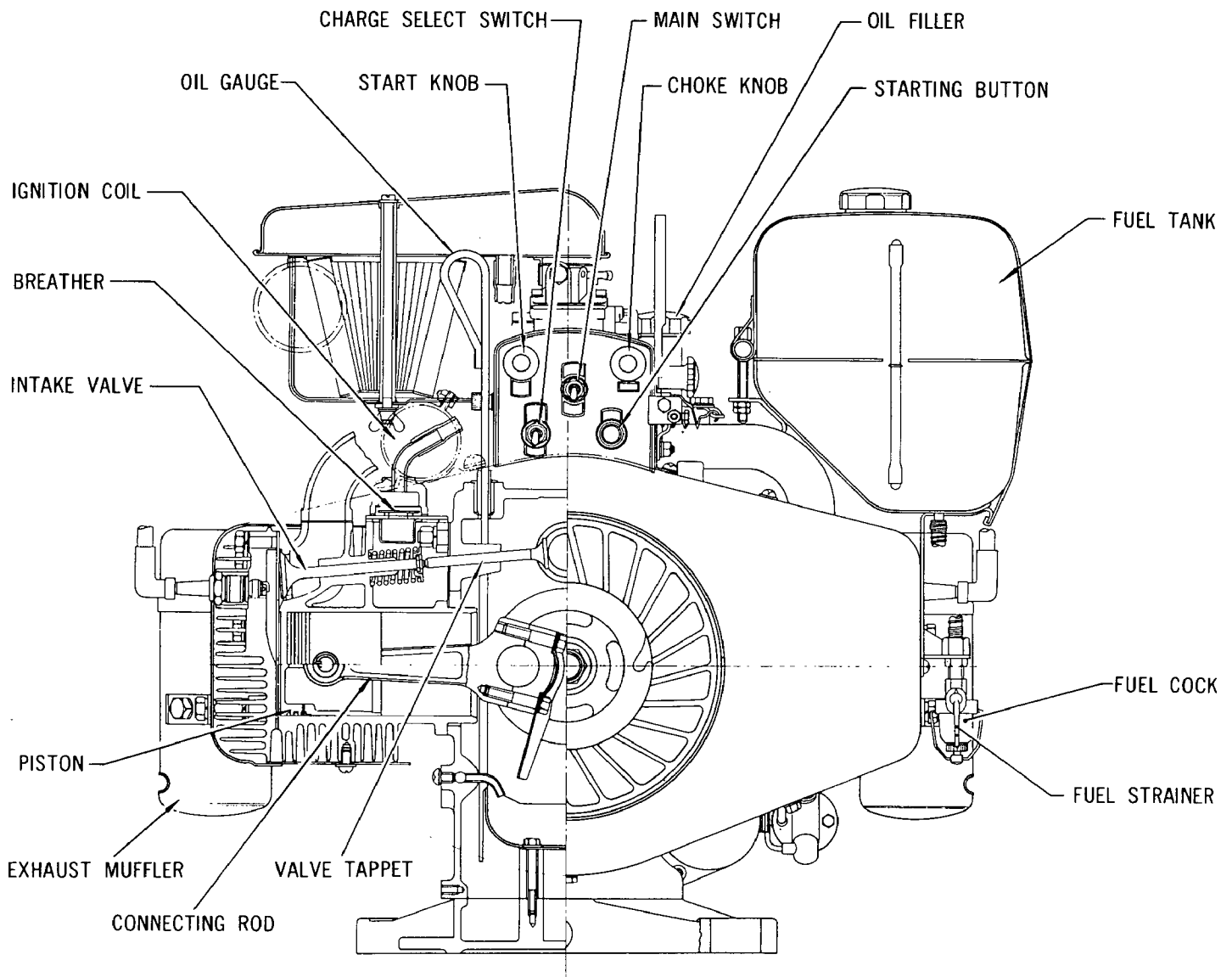

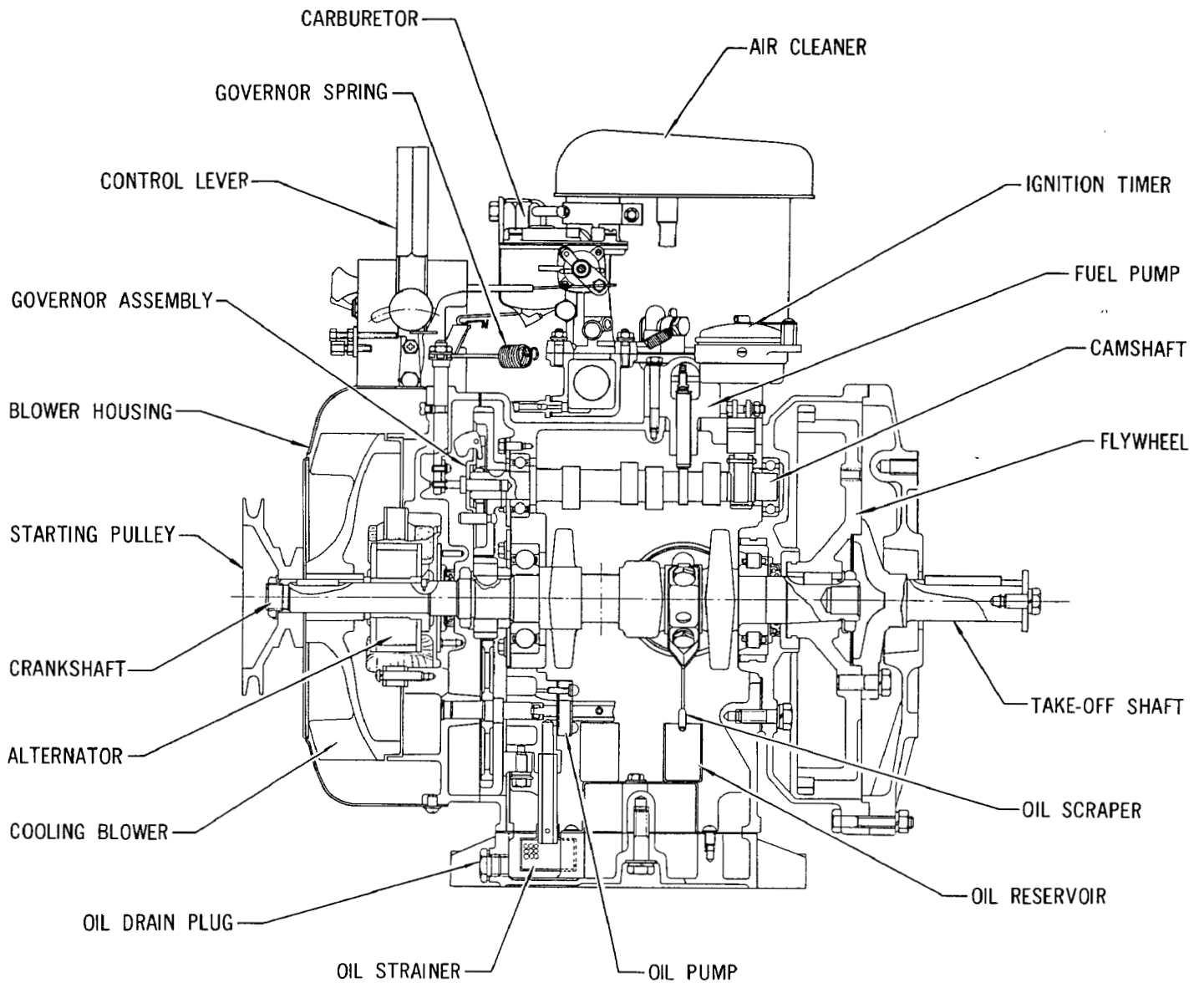

4-2 CRANKCASE

The crankcase made of an aluminum alloy casting incorporates on its blower side a gear case that receives a gear case cover. On the blower side of the crankcase, two ball bearings are mounted, each supporting the crankshaft and the camshaft. On the other side of the crankcase, one each roller bearing and ball bearing are mounted in the main bearing cover, supporting the other ends of the crankshaft and the camshaft. To the bottom of the crankcase, an aluminum alloy engine base is attached, which serves both as an oil pan and as a mounting base.

4-3 CYLINDER AND CYLINDER HEAD

The cylinders made of special alloy cast iron are provided with many fins for cooling effects. They have an intake valve and an exhaust valve in the upper part.

The cylinder heads are made of aluminum alloy castings and have cooling fins. A spark plug is installed in the center portion of these castings.

4-4 CRANKSHAFT

The crankshaft is machined from a carbon steel forging and has two crankpins displaced 180° each other.

On the blower side of the crankshaft, an AC generator (or a magneto), a blower, and a starting pulley are mounted and on the driving side, a flywheel (a ring gear is fitted on it, in an electric starting engine) is mounted. The flywheel carries a driving shaft of alloy cast iron.

4-5 CONNECTING ROD AND PISTON

The connecting rods are machined from aluminum alloy forging, in which the forged alloy itself serves as the bearing metal at both ends. On the large ends, oil scrapers for splashing lubricating oil are attached.

The pistons are machined from aluminum alloy castings and are provided with two each grooves for compression rings and one each groove for an oil ring.

4-6 CAMSHAFT

The camshaft is made of a special alloy steel and incorporates five cams, two each for the intake and exhaust valves and one for the fuel pump.

On the camshaft, also a spiral gear for driving the contact breaker is force-fitted. The camshaft is driven by the crankshaft at half its speed over pair of helical gears.

4-7 GOVERNOR

The flyweight type governor assembly is mounted on the camshaft gear, and controls the carburetor throttle automatically, to maintain the engine revolution at a selected speed under a varying load. (for details, refer to Section "8 GOVERNOR").

4-8 COOLING

Cooling is accomplished by a flow of air from a cooling blower mounted on the crankshaft end, guided by cylinder buffles and head covers into two streams right and left, and circulated past the cylinder fins.

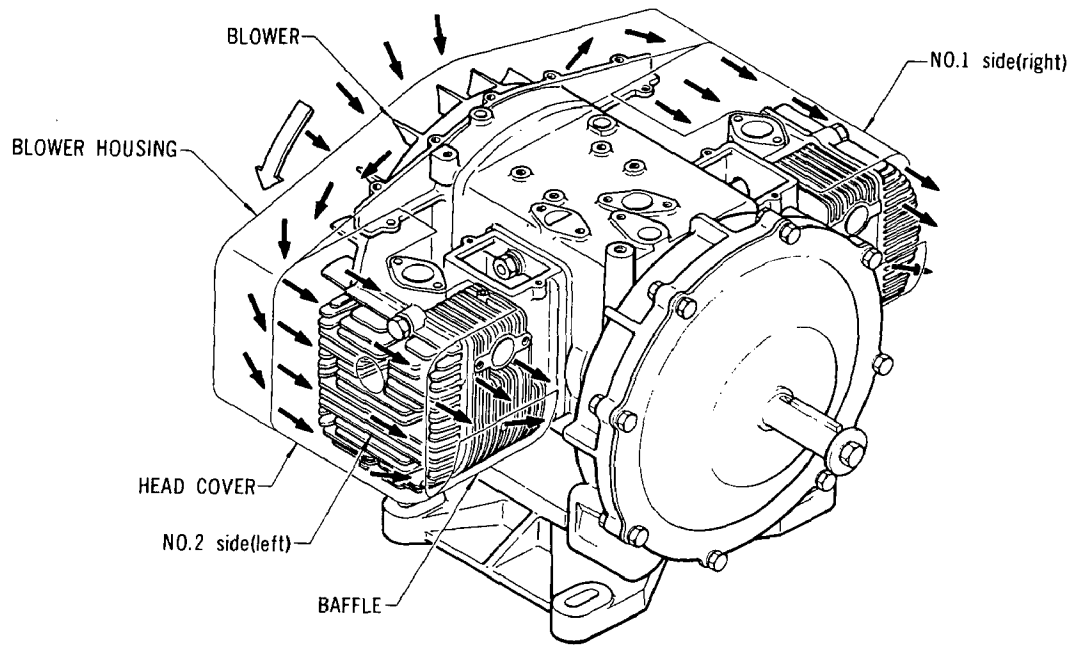

Fig. 4-8

4-9 LUBRICATION

All the internal sliding surfaces are lubricated by the oil scooped up from two oil troughs in the engine and splashed over by two oil scrapers attached to the connecting rods.

The troughs are kept filled with oil by a trochoid gear pump driven from the crankshaft by gears.

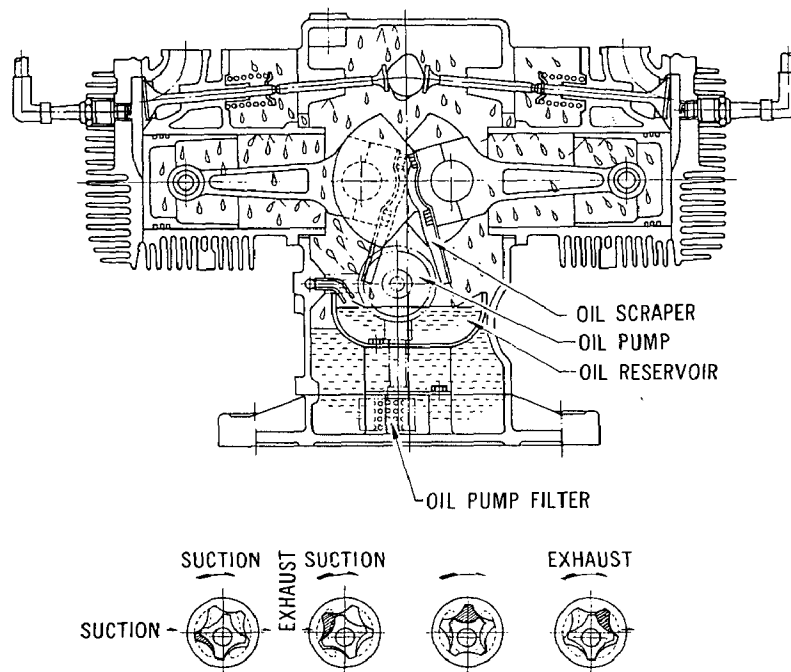

Fig. 4-9

4-10 CARBURETOR

A down draft type carburetor is employed. Its setting has been carefully determined after thorough testing to achieve best starting, acceleration, fuel consumption, output and other performances.

For more details such as the construction, refer to Section "9. CARBURETOR".

4-11 AIR CLEANER

This is a cyclone type air cleaner, in which the dust particles in the air entering through the intake pipe, are thrown onto the felt lining in the dust case, and are caught by it, through the vortex motion of the air. The air is further cleaned by passing through a filter element before flowing into the carburetor.

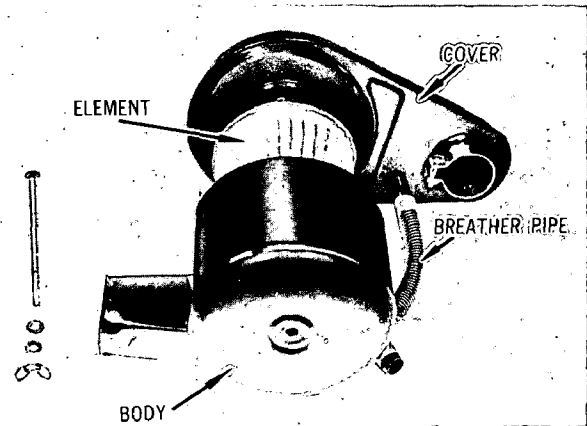

Fig. 4-11

4-12 IGNITION

The circuit breaker shaft is driven at half the crankshaft speed by a spiral gear, force-fitted on the camshaft. The breaker cam, which is equipped with an automatic advancer, has two lobes to actuate one pair of breaker points.

For every rotation of the crankshaft, one each spark is produced in both the right and left cylinders simultaneously, and of these sparks, every other one alternately produced in either cylinder is an idle spark. The battery ignition engine (EY21AS) and the magneto ignition engine (EY21B) have breaker cams of different lobe forms.

The battery ignited model (EY21AS) is equipped with an ignition coil, mounted at the top left corner of the blower housing.

For more details, refer to Section "7. ELECTRICAL EQUIPMENT".

4-13 SELENIUM RECTIFIER

The selenium rectifier, mounted inside the No. 1 side cylinder shroud, serves to rectify the AC current generated by the AC generator into DC current to charge the battery.

4-14 CLUTCH

With this dry single disc clutch, engagement is effected by a spring tension, and disengagement is effected by a manually operated clutch lever.

4-15 REDUCER

In this reducer, the speed of the crankshaft is reduced to its half rate by a 1/2" double chain. The direction of the output shaft is the same as that of the crankshaft, that is, counter-clockwise as viewed from the driving side.

5. INSTALLATION

The life, ease of maintenance, frequency of checks and repairs, and operating cost of an engine are greatly affected by the way the engine is installed. When installing your engine, therefore, the following contents must be studied thoroughly.

5-1 INSTALLING

When installing the engine, its position, coupling conditions with operating machine, and anchoring or supporting methods must be carefully studied.

Especially, when deciding the installing position, consideration must be given to the convenience of such routines as pouring and checking of fuel and oil, checking of the spark plugs and breaker points, maintenance of the air cleaner element, oil draining, and checking and installation of the battery.

(refer to equipment drawing)

The engine should be installed as level as possible. The limit of inclination is 25° in the direction of the crankshaft and 15° in the lateral direction.

In installing the engine, four base washers delivered in the tool box should be used.

5-2 VENTILATION

The engine must be supplied with fresh air for cooling and fuel combustion. When the engine is to be operated in a cover or in a small room, a proper means must be provided for cooling air circulation or ducts and baffle plates for guiding cooling air, because if the temperature in the engine compartment is allowed to rise, vapor lock, oil deterioration, increase of oil consumption, power reduction, loss of engine life or other troubles develop, and proper operation is harmed. The temperature of the engine compartment should be maintained below 60°C even in summer.

5-3 EXHAUST GAS EVACUATION

Since the exhaust gas from the engine is toxic, when the engine is operated indoors, the exhaust gas must be evacuated to the outside. As the output power of an engine is considerably influenced by the length of the exhaust duct, its diameter must be increased in proportion to its length.

Exhaust pipe length below 1m: pipe ID above 27mm

Exhaust pipe length below 3m: pipe ID above 30mm

Exhaust pipe length below 5m: pipe ID above 33mm

When an extra suppression of the exhaust noise is required, an optional special muffler is available. (refer to Photo)

5-4 FUEL SYSTEM

When connecting the fuel pipe, the piping must be carefully examined for heat conductivity, diameter, bending, and leakage through the fittings, to eliminate air lock and vapor lock. Because the engine is equipped with a fuel pump, the fuel tank position may be freely selected below the carburetor (within approx. 80cm).

The standard ID of the fuel pipe is 5mm. When a very long pipe is required, or when the tank is installed more than 80cm below the carburetor, an electromagnetic pump must be utilized.

A fuel strainer must always be used between the tank and the fuel pump.

5-5 CONTROL BOX AND REMOTE CONTROL

A control box for engine control, equipped with a main switch, charge select switch, start knob, choke knob, start button and control lever is mounted atop the blower housing.

MAIN SWITCH: The on-off switch for the engine electric circuit

CHARGE SELECT SWITCH: For switching lights (when used) and for switching the quick battery charge circuit on and off.

START KNOB:

CHOKe KNOB: For operating the carburetor start valve.

START BUTTON: For energizing the starting motor

CONTROL LEVER: For controlling speed by operating the carburetor throttle.

* Model EY21 engines can be remote-controlled in one of the following models:

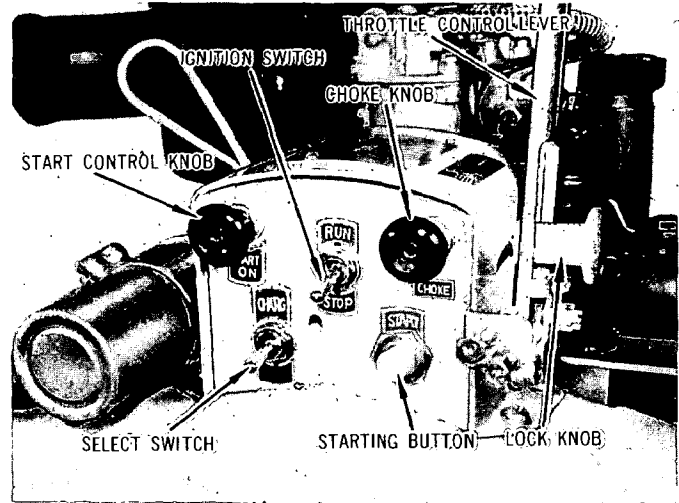

Fig. 5-5

5-5-1. REMOTE-CONTROL OF SPEED ONLY

For this mode, the standard control box is utilized.

With speed control lever at the lowest speed position, insert wire and outer cable through adjust bolt.

With wire lever at the lowest position, clamp wire to wire lever firmly with set screw. Be sure to install wire return spring (not an engine part) in this case. Screw adjust bolt in or out so as to stop speed control lever at 3000 rpm, 2500 rpm, or whatever speed normally utilized. Lock adjust bolt with lock nut after adjustment.

The above speed refers to the speed of the output shaft of a direct drive engine and a clutch engine, and the speed of the output shaft of a reduction drive engine and a clutched reduction drive engine is half the value.

5-5-2 The engine can be started, stopped and speed-controlled remotely in either of the following modes:

- 1) Controlling from drive side
- 2) Controlling from fan side
- 3) Control box for remote control

For the remote control modes 1) and 2), this control box is available.

5-6 POWER TRANSMISSION TO DRIVEN MACHINES

5-6-1 BELT DRIVE

V-belts are preferable to flat belts.

In arranging a belt transmission, consideration must be given to the following points:

- *The driving shaft of the engine and the driven shaft of the machine must be parallel.
- *The driving pulley of the engine and the driven pulley of the driven machine must be aligned correctly.

*The driving pulley must be mounted as near the engine as possible.

*As far as possible, the belt must be spanned horizontally.

*When starting the engine, the load must be disconnected from the engine. If a clutch is not available, a tension pulley or other means must be employed.

5-6-2 FLEXIBLE COUPLING

When a flexible coupling is used, the runout and mis-alignment between the driven shaft and the engine shaft must be made as small as possible.

The tolerances on the runout and mis-alignment are specified by each coupling maker.

5-7 WIRING

The wiring is executed in the following modes, classified according to the ignition method, charging method, and starting method:

ignition	charging	starting	remark
Battery ignition (Model EY21AS)	Alternator	Starting motor or rope starting	Standard
	Alternator with Diode		This alternator with diode is utilized when the charging capacity of the alternator is insufficient due to frequent starting and low speed operation.
Magneto ignition (Model EY21B)	unnecessary	Rope starting	Standard

The wiring diagrams are shown below. In these diagrams, ○ represents a terminal and □ represents a connector. As the portions indicated by dotted lines are not wired in the engine at the factory, the cables shown in 5-7-4 must be prepared by the users.

5-7-1 EY21AS, battery ignition and motor starting (standard)

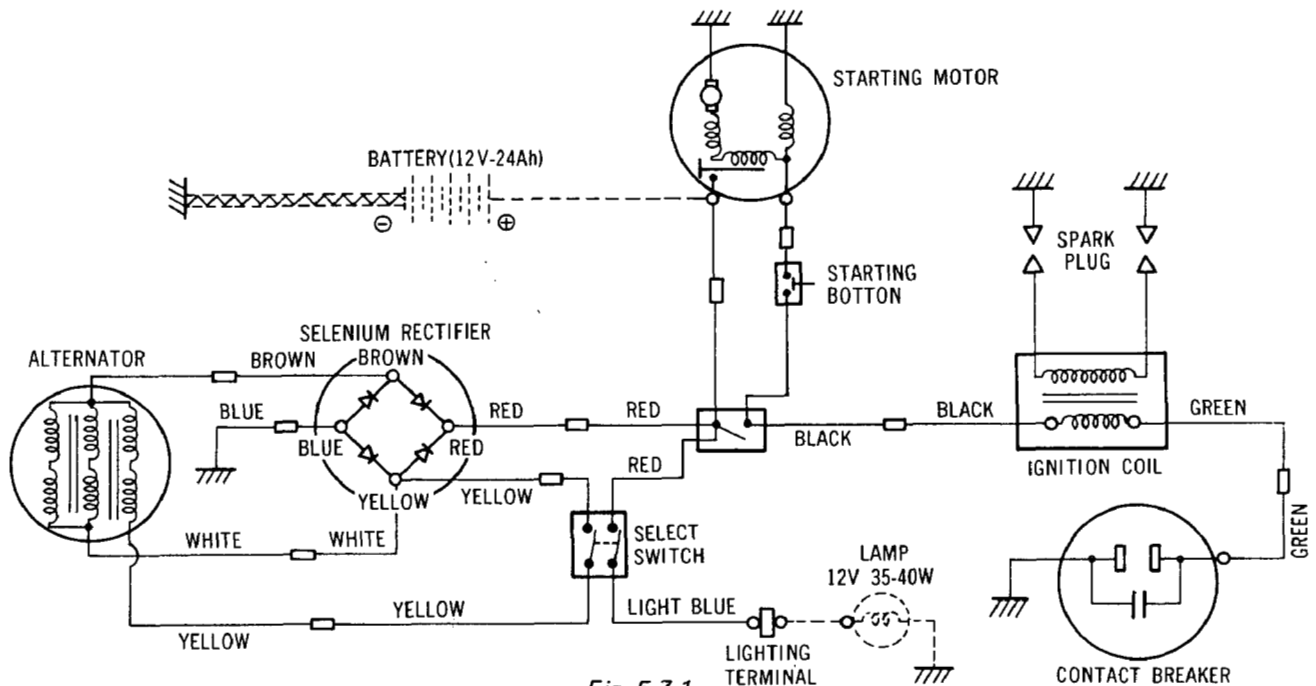

Fig. 5-7-1

5-7-2 EY21B magneto ignition and rope starting (standard)

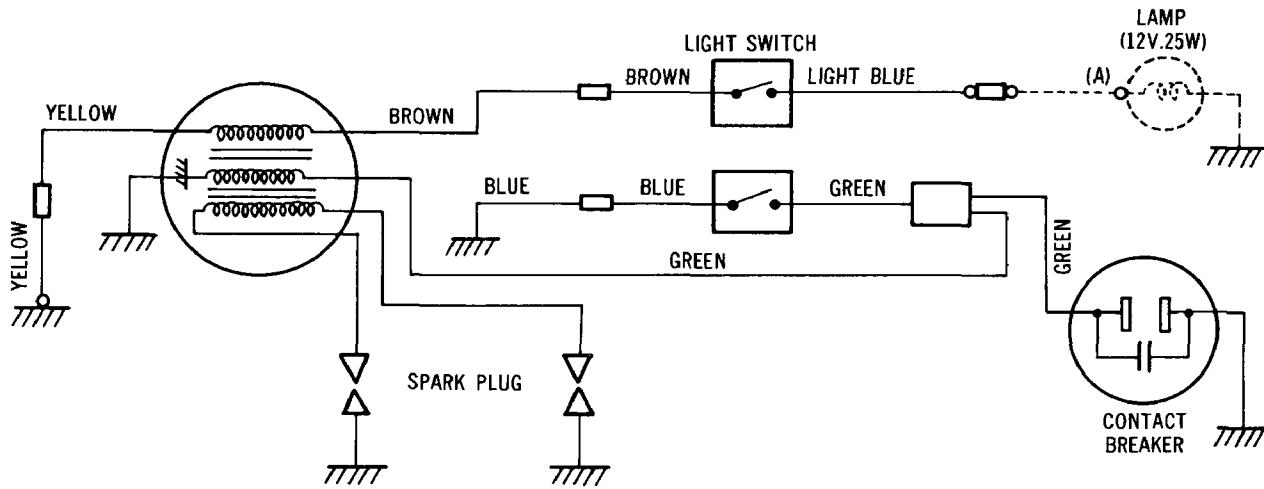

Fig. 5-7-2

5-7-3 Battery ignition engine with starting motor and alternator with diode.

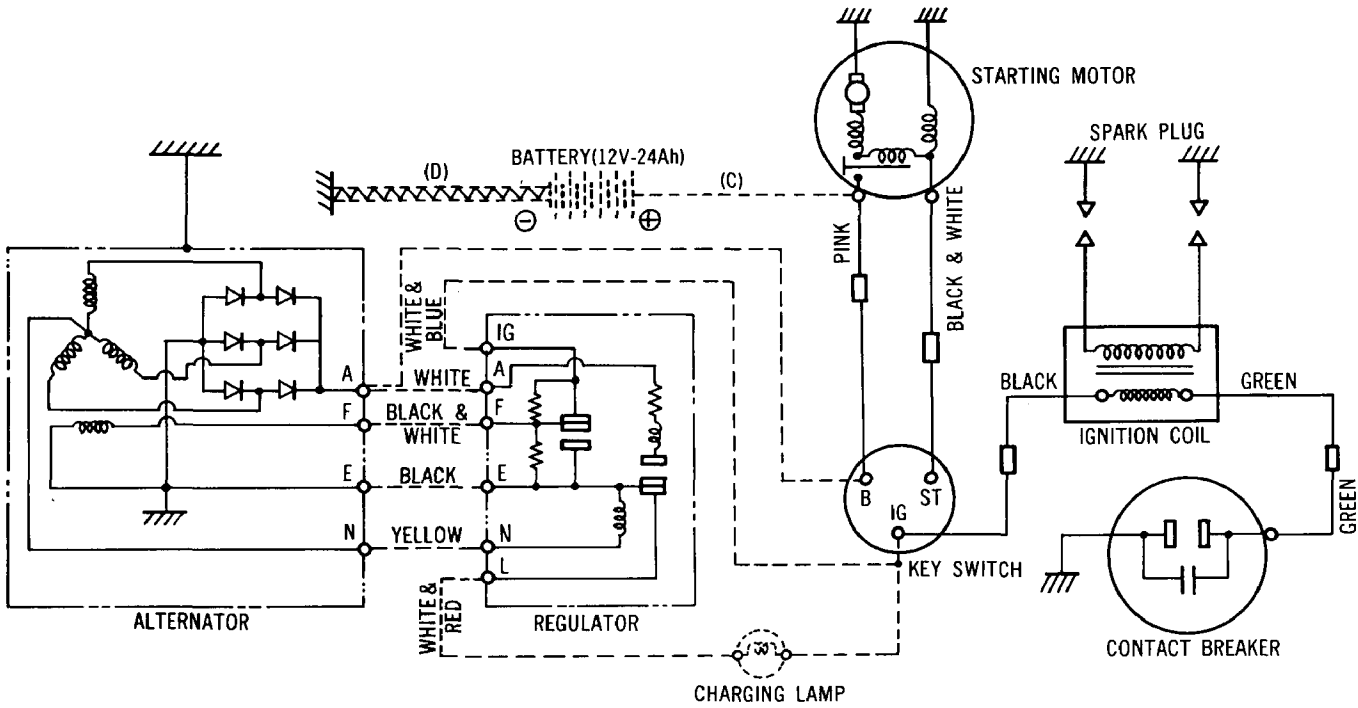
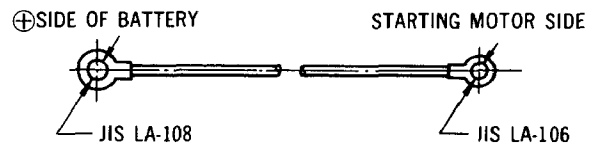

Fig. 5-7-3

5-7-4 WIRE AND CABLE RECOMMENDATIONS

1) STARTING MOTOR CABLE

Length	size	dia.
below 1.5m	JIS AV15b	7.3mm
1.5~2.5m	JIS AV20b	8.5mm
2.5~4m	JIS AV30b	10.8mm



2) GROUND LEAD

Tighten around lead firmly on an uncoated metallic surface of the engine which is in perfect electrical connection with the crankcase.

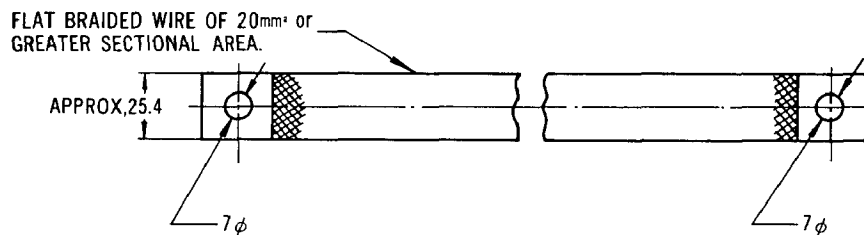

3) CABLE FOR LAMP

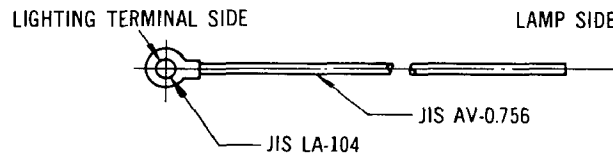

4) The sizes of other wires are indicated in the diagram.

CAUTIONS

1. Each wire is identified by color. Connect wires of the same color with connectors. Be sure to insert the connector plugs fully into the respective receptacles.
2. Connect the battery (+) terminal to the starting motor and the (-) terminal to the engine ground point. Never connect the battery in reverse, as a severe damage will result from doing so.
3. Do not disconnect the battery while the engine is running (battery ignition engine only), as the selenium rectifier may get burnt by doing so.
4. To prevent an inadvertent shorting with a wrench or other tools, be sure to connect the (+) side of the battery first when installing the battery, and disconnect the (-) side first when removing the battery.

6. DISASSEMBLY AND REASSEMBLY

6-1 PREPARATIONS AND SUGGESTIONS

6-1-1 DISASSEMBLY

- 1) When disassembling the engine, memorize where and how each part is assembled in order to be able to reassemble it correctly. Tag parts if there is a possibility of confusion.

Because this engine is a twin-cylinder engine, pay particular attention to keep the parts belonging to the No. 1 side, left and the No. 2 side, right, separately so as not to confuse them.

- 2) Prepare several boxes to keep parts belonging to respective groups together.
- 3) Take care not to damage packings and gaskets, which are vulnerable.
- 4) In order to prevent missing and misplacing, group related parts together, tentatively assembling them, immediately after disassembling each sub-assembly.
- 5) Use the correct tools in the correct way.
- 6) Standard tools required for disassembling:
work table; washing pan; disassembling tools; whishing oil (kerosene or gasoline); mobile oil; emery paper; cloth
- 7) Be sure to drain fuel and oil prior to disassembly.

To drain oil, unscrew drain plug located at the lower side of the crankcase near the blower housing.

To drain fuel, disconnect the fuel pipe between the fuel tank and the strainer at the union near the strainer.

6-1-2 CLEANING BEFORE REASSEMBLY

- 1) Check all sliding and rotating parts, pistons, cylinders, valves, camshaft, crankshaft, gears, and bearings for defects.
- 2) Wash the disassembled parts in kerosene to remove dust, dirt and contaminated oil thoroughly. Wash them twice, first time removing visible dirt roughly, and second time using fresh kerosene. After washing, blow them thoroughly with compressed air.
- 3) Do not wash electric parts. Wipe them with dry cloth to clean and dry them.

6-1-3 REASSEMBLY

- 1) Before reassembly, wash parts in gasoline and blow them with compressed air.
- 2) Apply mobile oil on the rotating and sliding surfaces.
- 3) Take care not to contaminate the parts with dust during reassembly.
- 4) Make sure that the parts belonging to the No. 1 side are not confused with the parts for the No. 2 side. Make sure also that identical parts and symmetrical parts are reassembled in exactly same position and direction as they were before disassembly.
- 5) Be sure to assemble those parts provided with alignment marks by bringing the marks in alignment.
- 6) Tighten bolts, nuts and screws to the correct torque readings specified. When there is no torque specification, tighten them to torque readings appropriate to their sizes. If small screws are tightened too strongly, they may get broken.
Tighten the larger screws such as ones for the crankshaft and camshaft, sufficiently by giving hammer blows on the socket wrench handle.
When tightening several screws fastening a single part, tighten them all evenly, by alternately tightening diagonally located pairs.
- 7) Each time major part has been reassembled, turn the moving part by hand to check for friction and noise.

6-2 STANDARD TOOLS

- | | | |
|----------------------------|--------------------------|---------------------|
| 1) Tool box | 8) 14 × 17mm wrench | 14) } Set of puller |
| 2) 10 × 12mm socket wrench | 9) Breaker wrench | 15) } |
| 3) 14 × 17mm socket wrench | 10) Screwdriver | 16) } |
| 4) 21mm socket wrench | 11) Phillips screwdriver | 17) Rope |
| 5) 27mm socket wrench | 12) 12 × 14mm box wrench | 18) Funnel |
| 6) 7 × 8mm wrench | 13) Handle | 19) Base washer |
| 7) 10 × 12mm wrench | | 20) Spark plug |

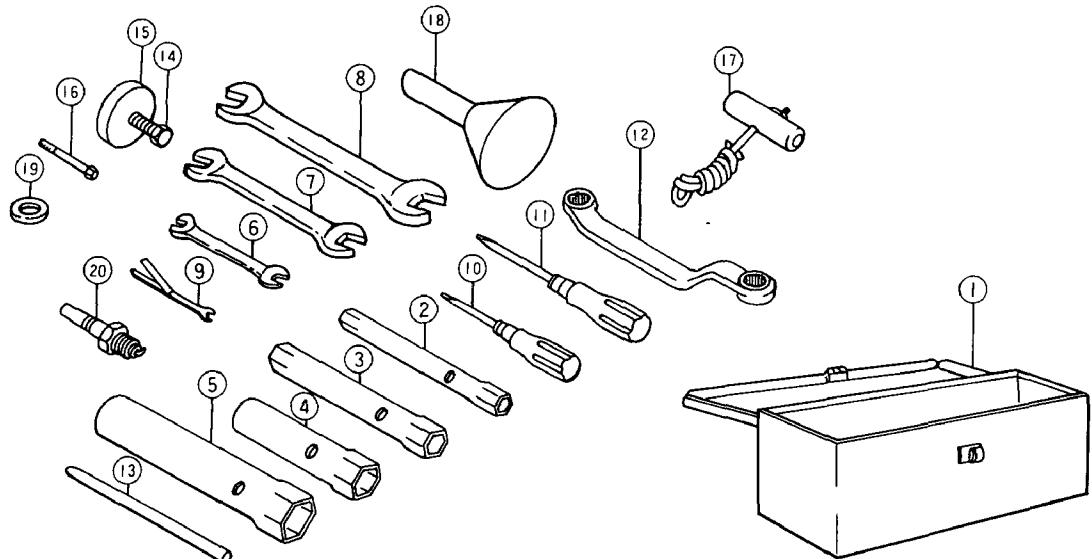

Fig. 6-2

6-3 SPECIAL TOOLS

- 38mm socket wrench: Y750-05
 Flywheel puller: Y790-349

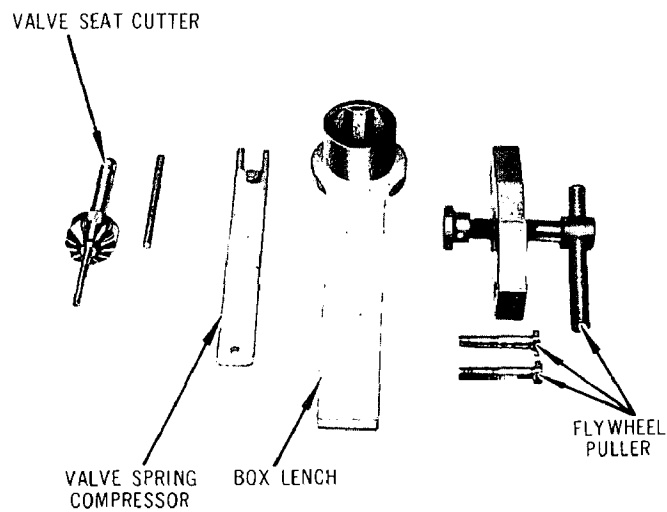

Fig. 6-3

6-4 DISASSEMBLY AND REASSEMBLY PROCEDURES

6-4-1 FUEL TANK AND FUEL TANK BRACKET

- 1) Disconnect fuel pipe between strainer and fuel pump at fuel strainer.
- 2) Remove fuel tank, bracket and strainer as one assembly from crankcase.
(10mm bolt 2 pieces, 8mm nut 2 pieces, 6mm screw 1 piece)

In reassembly;

When connecting the fuel pipe between fuel tank and strainer, tighten union nut before tightening the fuel strainer mounting nut.

6-4-2 AIR CLEANER AND OIL GAUGE

- 1) Remove oil gauge in order to prevent it from getting damaged.
- 2) Disconnect breather pipe at tappet chamber.
- 3) Loosen clamp band at carburetor, unscrew wing nut at bottom of air cleaner, and remove air cleaner as a complete assembly.

In reassembly;

- 1) Replace element or wash it in liquid detergent solution, closing top hole with hand and vigorously shaking it up and down until all dust is removed. After washing, dry element thoroughly and apply mixture oil (commercial pre-mixed fuel or 20:1 gasoline oil mixture).
- 2) Clean felt lining inside dust collecting body by applying the above mixture oil or gasoline and rubbing with fingers. Dry thoroughly and apply engine oil.
- 3) Reassemble all the relevant parts that have been treated according to the above. When installing air cleaner, direct its intake side towards the dust-free and cool side.

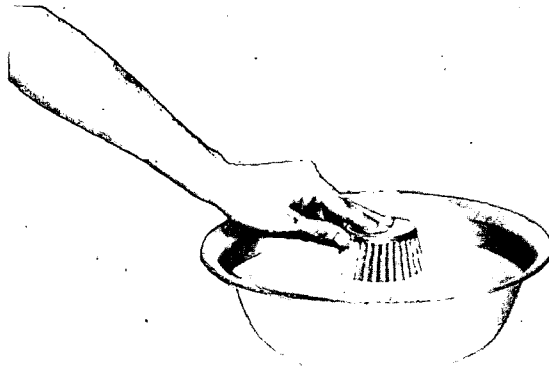

Fig. 6-4-1

6-4-3 IGNITION COIL (for Model EY21AS)

- 1) Disconnect high-tension cables from spark plugs and remove cable clips from head cover. (8mm screw 2 pieces)
- 2) Disconnect primary wire from ignition coil
- 3) Remove ignition coil from blower housing. (8mm screw 2 pieces)

6-4-4 CONTROL BOX

- 1) Disconnect electrical wires at connectors.

CAUTION: BE CAREFUL NOT TO PULL WIRES OUT OF CONNECTORS.

- 2) Remove control rod that connects speed control lever and control lever.
- 3) Disconnect choke wire from carburetor starter valve. (1 position)
- 4) Disconnect start wire from carburetor. (2 positions)
- 5) Remove governor return spring and remove control box from blower housing. (6mm screw 3 pieces)

In reassembly;

Insert electrical wire connectors to their full depth.

6-4-5 GOVERNOR, CONTROL LINKAGE AND CARBURETOR

- 1) Unhook governor spring from control lever.
- 2) Remove control lever.
- 3) Remove governor lever together with governor rod and rod spring that are connected to carburetor throttle lever. (8mm nut, 1 piece)
- 4) Disconnect fuel pipe from fuel pump and remove carburetor from intake manifold.
- 5) For disassembly and reassembly of carburetor, refer to Section "9. CARBURETOR".

In reassembly;

- 1) Attach governor rod and rod spring to carburetor throttle lever and mount carburetor on intake manifold.
- 2) Proceed in reverse order to the disassembly procedures given above.
- 3) For linkage and speed regulation, refer to Section "8. GOVERNOR".

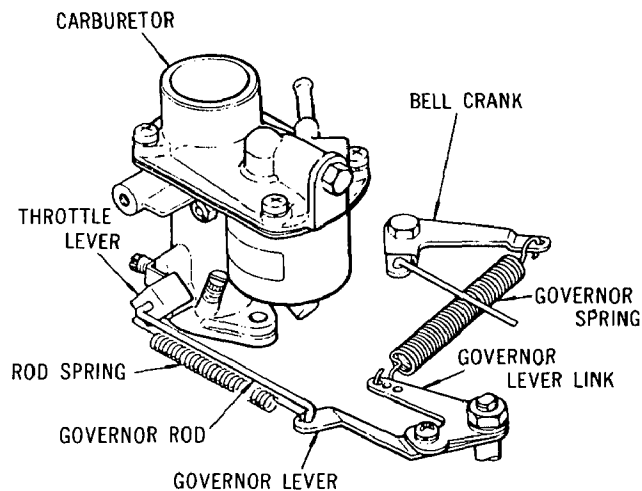

Fig. 6-4-2

6-4-6 CONTACT BREAKER

- 1) Unscrew contact breaker fastening bolts and nuts from retainer (contact breaker).
- 2) Take out contact breaker from crankcase.
- 3) Remove retainer (contact breaker) from crankcase. (6mm bolt, 1 piece)

In reassembly;

- 1) When inserting contact breaker into crankcase, the former should slip in up to the bottom O-ring at the contact breaker case smoothly. If there is an excessive resistance, the gears are jamming. Do not try to force it in. Withdraw it slightly and reinsert it after turning it a little.
- 2) After completely reassembling engine, adjust breaker point gap and timing, referring to Section "7-5. TIMING ADJUSTMENT".

6-4-7 FUEL PUMP

Remove fuel pump and bracket together from crankcase. (6mm bolt 2 pieces)

In reassembly;

Take care not to reverse inlet and outlet sides after disassembly.

6-4-8 OIL FILLER AND INTAKE MANIFOLD

- 1) If necessary, oil filler can be removed from crankcase. (6mm screw, 2 pieces)
- 2) Remove intake manifold along with drain tube assembly from cylinders.

In reassembly;

Tightening torque for intake manifold mounting bolts;

69 kg-cm (5 ft-lb)

6-4-9 FLYWHEEL COVER AND DRIVING SHAFT

- 1) Remove flywheel cover from main bearing cover at drive end of engine. (8mm bolt, 8 pieces)
- 2) Disassemble driving shaft from flywheel. (10mm bolt, 8 pieces)

6-4-10 MUFFLER (right and left)

Remove two mufflers by unscrewing nuts (8mm, 4 pieces) from exhaust flange studs on cylinders and cylinder head bolts (8mm, 2 pieces) at muffler support brackets.

6-4-11 STARTING MOTOR

- 1) Disconnect electric wires at connectors.
- 2) Remove starting motor from main bearing cover. (8mm nut, 2 pieces)

6-4-12 HEAD BAFFLES (right and left) AND BLOWER HOUSING

- 1) Remove cylinder head baffles (6mm screw, 6 pieces) and bottom baffles (6mm screw, 3 pieces; 6mm bolt, 2 pieces)
- 2) Remove blower housing from gear case cover. (8mm bolt, 1 piece; 6mm screw, 7 pieces)
- 3) Remove bottom baffles (right and left) from gear case cover. (8mm bolt, 1 piece; 6mm screw, 3 pieces)

CAUTION: DISCONNECT RECTIFIER WIRES AT CONNECTORS BEFORE REMOVING BOTTOM BAFFLE ON THE LEFT SIDE.

Rectifier can be removed if necessary.

6-4-13 STARTING PULLEY AND COOLING BLOWER

- 1) Straighten lock washer.
- 2) Apply a socket wrench over starting pulley nut and give wrench handle a sharp blow in the unscrewing direction with a soft hammer.
- 3) Remove nut, lockwasher, starting pulley and dust cover.
- 4) If cooling blower cannot be pulled off by hand, attach puller to blower and turn center bolt clockwise until blower becomes sufficiently loose to be removed. (see Fig. 6-4-3)

Remove key out of crankshaft.

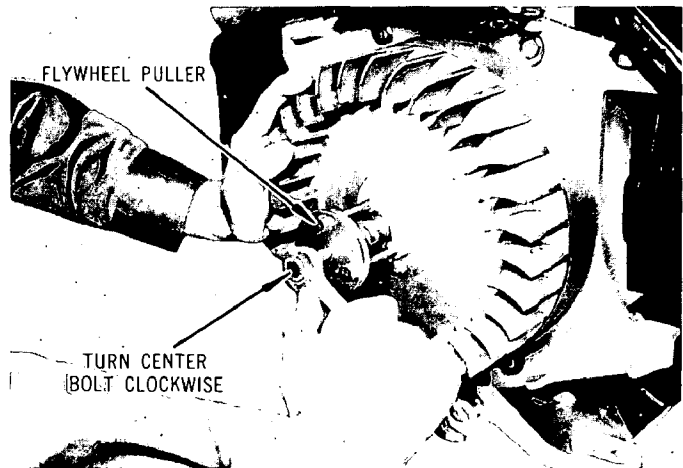

Fig. 6-4-3

In reassembly;

Be sure the key is in position on the shaft and that the keyway in the blower is lined up accurately with the key. Mount blower on crankshaft and slip a piece of pipe over the end of the crankshaft and against the hub of the blower.

Gently tap the end of the pipe until cooling blower is securely in place.

Mount dust cover and pulley. Place lockwasher on shaft with tab fitted into key slot, and securely tighten locknut. If torque wrench is available, tighten to 533kg-cm (40 ft-lb). Fold lockwasher over hex flat of locknut.

6-4-14 ALTERNATOR AND MAGNETO

○ ALTERNATOR (Model EY21AS)

- 1) Remove spacer and rotor from crankshaft.
- 2) Remove wire clip (6mm screw, 1 piece) and unscrew stator mounting screws (6mm, 6 pieces).
- 3) Disconnect wires at connectors, and remove stator from gear case cover.

○ MAGNETO (Model EY21B)

- 1) Remove rotor from crankshaft.
- 2) Remove wire clips (6mm screw, 3 pieces) and unscrew coil assembly mounting screws (6mm, 2 pieces).
- 3) Disconnect wires at connectors and remove stator from gear case cover.

In reassembly;

Between alternator and cooling blower, a spacer is inserted. (Model EY21AS): Between magneto and cooling blower, no spacer is inserted. (Model EY21B) Refer to Sections 7-1 AC ALTERNATOR and 7-3 MAGNETO.

6-4-15 GEAR CASE COVER

- 1) Unscrew gear case cover mounting bolts (8mm bolt, 6 pieces).
- 2) With a soft hammer, evenly tap around outer surface of cover to break it free from crankcase face.

CAUTION: CAREFULLY REMOVE COVER SO AS NOT TO DAMAGE OIL SEAL. LEAVE DOWEL PINS IN CRANKCASE FLANGE.

In reassembly;

- 1) Lubricate oil seal lips and coat cover face with thin oil film to hold gasket in place. Mount thrust washer on oil pump drive shaft (outside of gear), and align governor vane with plunger in camshaft. Be extremely careful not to damage or fold lips of oil seal when bringing it in contact with crankshaft shoulder.

CAUTION: MAKE SURE TIMING MARKS ON CRANKSHAFT AND CAMSHAFT GEAR, FIG. 6-4-4, ARE IN PROPER ALIGNMENT.

- 2) Tap gear case cover in place with a soft hammer and tighten cover bolts to 159kg-m (11.5 ft-lb) torque.

6-4-16 OIL PUMP DRIVE GEAR

- 1) Pull oil pump drive gear and shaft assembly out of oil pump bracket.

NOTE: Put thrust washer on outside of gear.

In reassembly;

Look into oil pump shaft hole of oil pump bracket and note position of flats on internal drive pin. So assemble oil pump drive gear that slot in gear shaft couples with the flats on drive pin. When this takes place, gear hub fits up against crankcase boss.

6-4-17 GOVERNOR

- 1) Remove thrust plate from between camshaft and governor flyweight.
- 2) Straighten lock washer, unscrew nut, and remove governor plate from camshaft.

In reassembly;

So install thrust plate that its flange fits in the jaw between heavy end and thrust tab of all four flyweights.

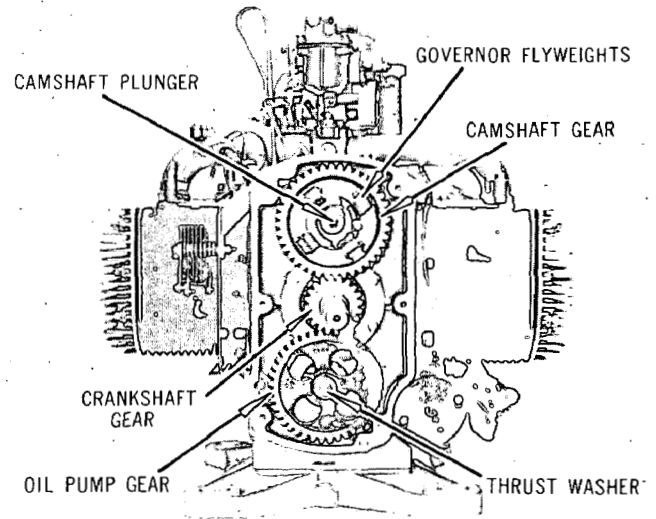

Fig. 6-4-4

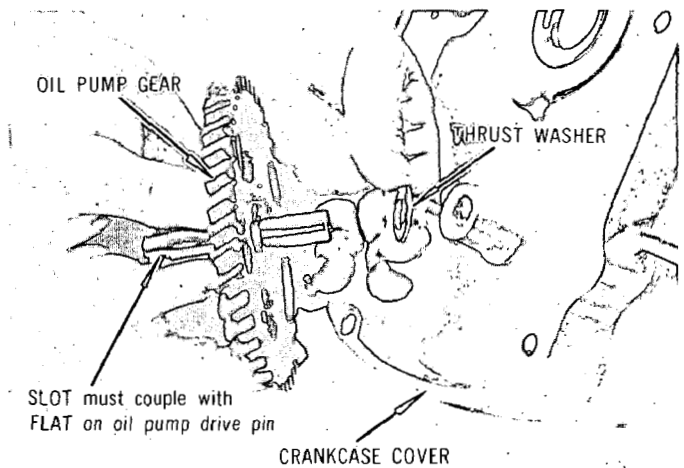

Fig. 6-4-5

6-4-18 CAMSHAFT GEAR

- 1) Remove camshaft gear from camshaft using aluminum bar and hammer.
- 2) Knock off woodruff key and remove spacer.

In reassembly;

- 1) Insert woodruff key in keyseat in camshaft and mount camshaft gear on camshaft, bringing marked tooth of crankshaft gear between two marked teeth of camshaft gear. (refer to Fig. 6-4-6)

CAUTION: IF VALVE TIMING IS OFF, ENGINE WILL NOT FUNCTION PROPERLY, OR MAY NOT RUN AT ALL.

- 2) Mount lock washer and tighten nut securely. If torque wrench is available, tighten to 553kg-cm (40 ft-lbs).
- 3) Fold lockwasher over hexagon flat of lock nut.

6-4-19 CRANKSHAFT GEAR

- 1) Straighten lock washer, place 38mm open end wrench onto lock nut and give wrench handle a sharp blow in the unscrewing direction with a soft hammer.
- 2) Remove lock nut, washer, and crankshaft gear from crankshaft.
- 3) Knock off woodruff key and remove spacer.

In reassembly;

Make sure woodruff key is in place in keyseat in crankshaft. Mount both spacer and crankshaft gear with the large internal chamfers toward the inside of engine. Prick punch timing mark on crankshaft gear tooth should face toward the outside. (Refer to Fig. 6-4-4)

- 2) Mount lock washer and tighten crankshaft gear lock nut securely to 898kg-cm (65 ft-lbs).
- 3) Fold lockwasher over hexagon flat of lock nut.

6-4-20 FLYWHEEL

- 1) Straighten out lock washer. Apply 38mm socket wrench on flywheel nut and give wrench handle a sharp blow in the unscrewing direction with a soft hammer. Unscrew nut and remove lock washer.
- 2) Attach flywheel puller to flywheel as shown in Fig. 6-4-7, and turn center bolt clockwise until flywheel becomes sufficiently loose to be removed. Knock key off crankshaft.

CAUTION: TAKE CARE NOT TO DAMAGE NEEDLE BEARING AT CRANKSHAFT END.

If flywheel puller is not available: While applying outward pull on flywheel, give several sharp blows on crankshaft end with a babbitt hammer. The flywheel will loosen sufficiently to be slid off the taper of the crankshaft.

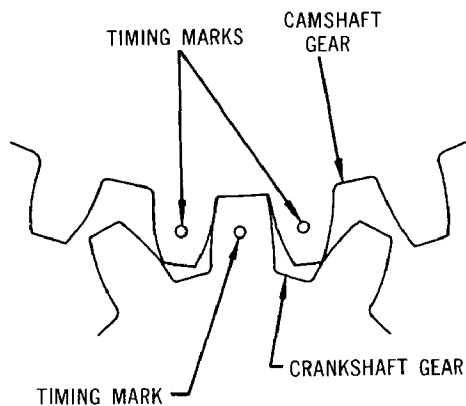

Fig. 6-4-6

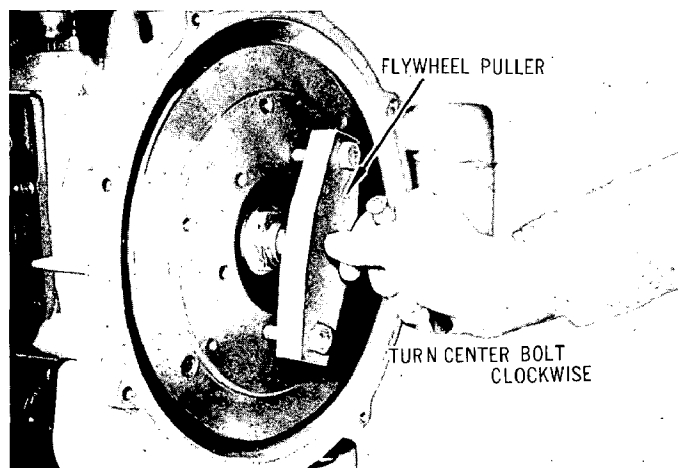

Fig. 6-4-7

In reassembly;

- 1) Make sure woodruff key is in position on crankshaft and keyway in flywheel is aligned accurately with key. After mounting, seat flywheel on crankshaft taper by slipping a piece of pipe over the end of crankshaft against crankshaft hub, and by striking the end of pipe sharply with a hammer.
- 2) Mount lockwasher and tighten flywheel nut securely to 895kg-cm (65 ft-lbs) torque.

Fold lock washer over hexagon flat of flywheel nut.

6-4-21 CYLINDER HEAD and SPARK PLUG

- 1) Remove spark plugs from cylinder heads, using 21mm socket wrench.
- 2) Unscrew mounting bolts (10mm, 16 pieces) with 17mm socket wrench and remove cylinder heads along with gaskets.

CAUTION: FOR REASSEMBLY, NOTE THE LOCATION OF FOUR TAPPED HEAD SPECIAL BOLTS FOR MUFFLER AND FUEL TANK BRACKET.

- 3) Remove carbon from combustion chambers and check cylinder head mounting face for distortion. If warpage is evident, replace head.

In reassembly;

- 1) Use new cylinder head gaskets and spark plugs. Mount gaskets (head) with their bead (folded edge) toward cylinder head face. Torque head bolts to 450~500kg-cm (32.5~36 ft-lbs).
- 2) Leave out spark plugs temporarily, for ease in turning engine over for remainder of assembly and for timing adjustment. When installing spark plugs, tighten to 345kg-cm (25 ft-lbs) torque.

6-4-22 INTAKE and EXHAUST VALVES

- 1) Remove tappet covers, breather bracket and gaskets from cylinders.
- 2) Lift valve springs, using compressor tool and remove retainer locks with long nose pliers.
- 3) Release compressor tool and remove intake valves, exhaust valves, springs and retainers.

CAUTION: DO NOT DAMAGE GASKET SURFACE OF TAPPET CHAMBER WITH COMPRESSOR TOOL.

- 4) Remove carbon and gum deposits from valves, seats, ports and guides.

In reassembly;

- 1) Replace valves, if valve face is pitted or warped.
- 2) Correct valve seat with 45° seat cutter tool, as illustrated in Fig. 6-4-9.

The finished seat width should be 1.1~1.4mm (0.047~0.059 inch).

Replace cylinder block when valve seat width and/or valve stem clearance become excessive. (see Fig. 6-4-10)

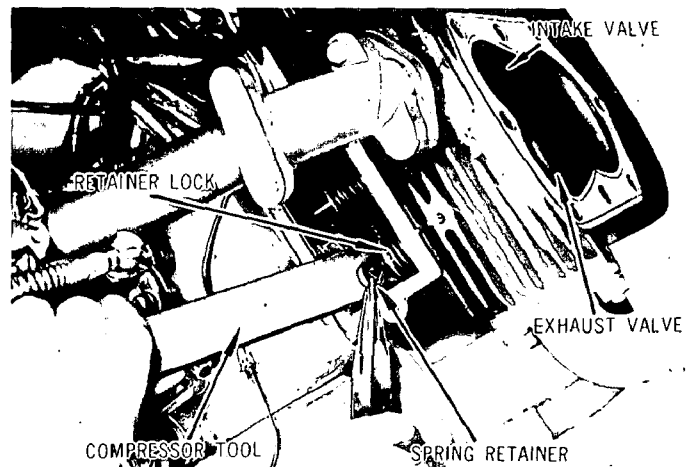

Fig. 6-4-8

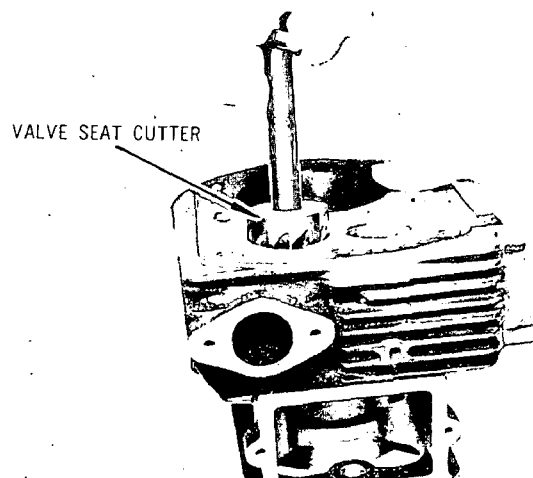

Fig. 6-4-9

A - VALVE FACE ANGLE		45°
B - SEAT ANGLE		45°
C - GUIDE INSIDE DIA.		8φ $\begin{matrix} +0.026 \\ 0 \end{matrix}$
D - VALVE STEM DIA.	INTAKE	8φ $\begin{matrix} -0.055 \\ -0.080 \end{matrix}$
	EXHAUST	8φ $\begin{matrix} -0.09 \\ -0.11 \end{matrix}$
MAXIMUM ALLOWABLE CLEARANCE BETWEEN C and D	INTAKE	0.091~0.116
	EXHAUST	0.176~0.146

VALVE and VALVE GUIDE CLEARANCE

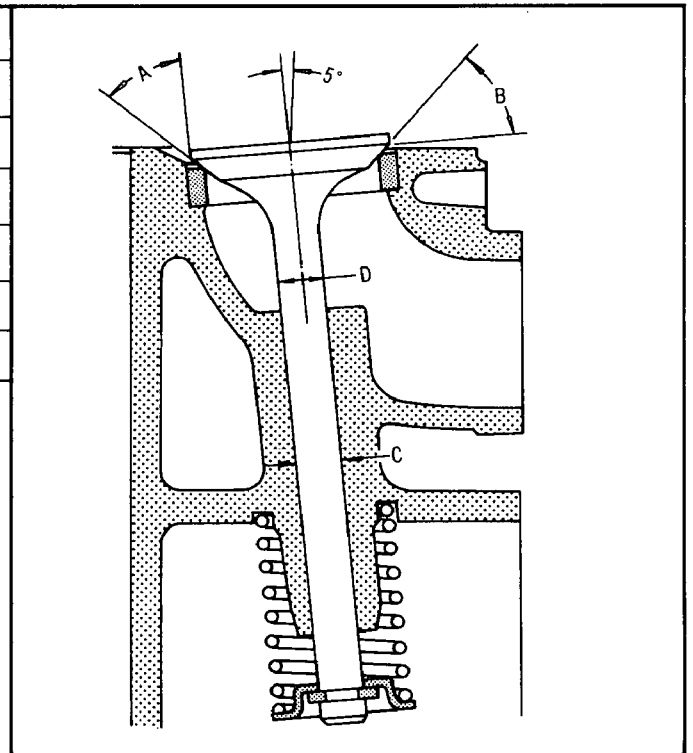

Fig. 6-4-10

- After correcting valve seats, lap valves in place until a uniform ring will show entirely around the face of valve. Clean valves, and wash block thoroughly in hot solution of soap in water. Wipe cylinder walls with clean lint-free rags soaked with light engine oil.

Assemble valve springs and spring retainers only after adjusting tappet clearance. (Refer to "TAPPET ADJUSTMENT")

4) TAPPET ADJUSTMENT

Rotate crankshaft until tappet is brought to its lowest position, hold valve down and insert feeler gauge between valve and tappet stem. The clearance for both intake and exhaust, with engine cold, must be 0.15~0.2mm (0.006~0.008 inch). If the clearance is less than it should be, grind end of valve stem a very little at a time and remeasure.

If the clearance is too large, sink valve seat with seat cutter tool. After obtaining correct clearance, assemble valve springs and spring retainers, and secure them in place with retainer locks. Check operation of valves by turning crankshaft over by hand and remeasure tappet clearance.

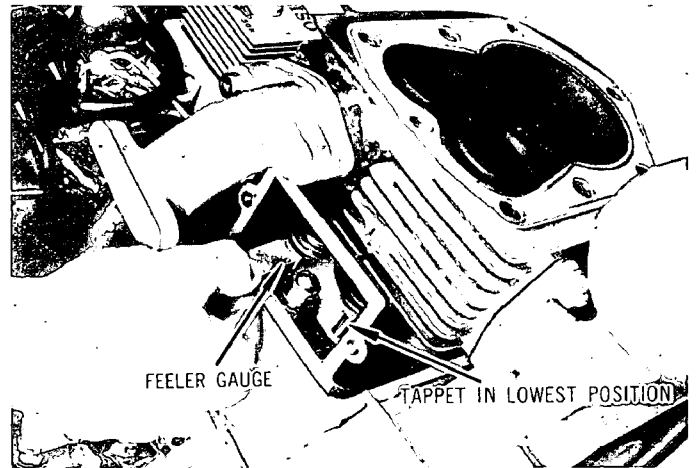

Fig. 6-4-11

6-4-23 CYLINDER BLOCK

If only the replacement of pistons and rings is required, it is not necessary that the complete engine be disassembled. To service the pistons and rings, the cylinder blocks are removed but the connecting rods may remain attached to the crankshaft.

- 1) Unscrew mounting nuts (10mm, 10 pieces) and remove cylinder blocks and gaskets from crankcase.

CAUTION: DO NOT ALLOW PISTON AND ROD TO FALL AGAINST CRANKCASE WHEN CYLINDER BLOCK IS REMOVED.

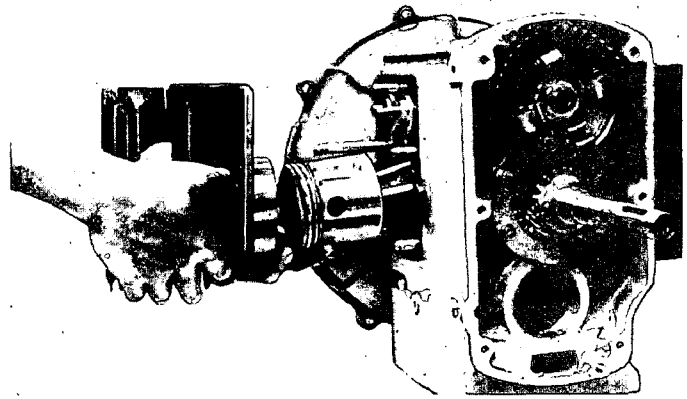

Fig. 6-4-12

- 2) Clean all dirt and foreign deposits from between cylinder block fins, and clean all carbon and gum deposits from valve chambers, seats and guide holes.
- 3) Mark cylinder blocks for identification so that they may be reassembled on the side they belong.

In reassembly;

Use a new cylinder base gasket. Apply oil to piston, rings and cylinder bore, and stagger piston ring gaps 180° apart around piston.

Tighten cylinder block mounting nuts to 310~350kg-cm (22.5~25.5 ft-lbs) torque.

6-4-24 PISTON AND PISTON RINGS

- 1) Remove piston pin retaining clips with long nose pliers. Gently tap piston pin out with a brass or aluminum bar and hammer.
- 2) Remove carbon deposit from piston, taking care not to scratch piston, and smooth out surface with oilstone.
- 3) Fit piston to cylinder bore—Measure diameter of piston in the center of thrust face at bottom of piston skirt. Refer to chart, Fig. 6-4-14 for clearance between piston and cylinder.
- 4) Remove piston rings from piston by widening ring gap and slipping rings over piston.

In reassembly;

1) PISTON RINGS

* Use a Ring Expander tool to prevent ring from becoming distorted or broken when installing onto piston.

* If an Expander tool is not available, install rings by first placing the open ends of ring on first piston land, and then carrying ring into correct groove, spreading it only far enough to slip over piston.

* Be extremely careful not to distort and brake ring.

Assemble rings in the order of oil ring, second ring and top ring. (see Fig. 6-4-13)

* Mount piston rings with a mark toward piston top.

Check for free movement of rings.

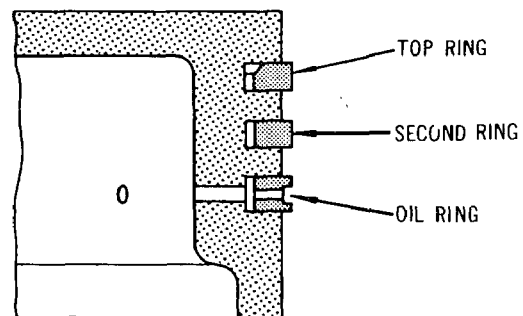

Fig. 6-4-13

2) PISTON

*Install piston to connecting rod by inserting piston pin. Be sure to insert clips at both ends of piston pin.

*Piston must be installed in cylinder with an identifying "F" mark on the piston top toward cooling blower end of engine.

6-4-25 CONNECTING ROD

- 1) Straighten out folded tabs of lock washers and unscrew bolts from connecting rod. Use 12mm thin wall socket wrench.
- 2) Remove lock washer, oil scraper and connecting rod cap
- 3) Mark connecting rod and piston assemblies so as to enable them to be reassembled in the same cylinders they were removed from.

In reassembly;

- 1) If the connecting rod bearing is scored, smooth the score out by using fine emery paper (#400).
- 2) Compressing piston rings with a suitable ring compressor, turn crankshaft to top of stroke and tap piston down until rod comes in contact with crank pin.

CAUTION: "F" MARK ON TOP OF PISTON MUST BE TOWARD BLOWER END OF ENGINE.

D (crankshaft pin Dia.)		$35\phi \begin{matrix} -0.050 \\ -0.075 \end{matrix}$
W (crankshaft pin Width)		$27 \begin{matrix} +0.1 \\ 0 \end{matrix}$
PISTON TO CYLINDER AT PISTON SKIRT THRUST FACE		0.048~0.108
PISTON RING GAP		0.05~0.25
PISTON RING SIDE CLEARANCE IN GROOVES	TOP RING	0.01~0.055
	SECOND RING	
	OIL RING	
CONNECTING ROD TO CRANK PIN	DIA.	0.050~0.100
	SIDE.	0.2~0.5
CONNECTING ROD TO PISTON PIN		0.026 ~ 0.046
PISTON PIN TO PISTON		0.009T ~ 0.01L

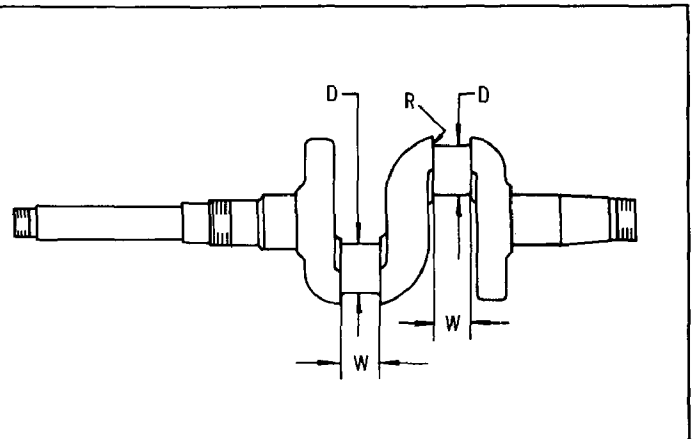

Fig. 6-4-14

- 3) The deep relief in the offset of connecting rod must be toward camshaft. Mount connecting rod cap so that cast dot on side of bolt boss matches up with an identical mark on connecting rod (both marks come on same side).

- 4) Attach oil scraper to rod cap with point of scraper toward bottom of crankcase.

(see illustration of "4-9 LUBRICATION SYSTEM" Fig. 4-9)

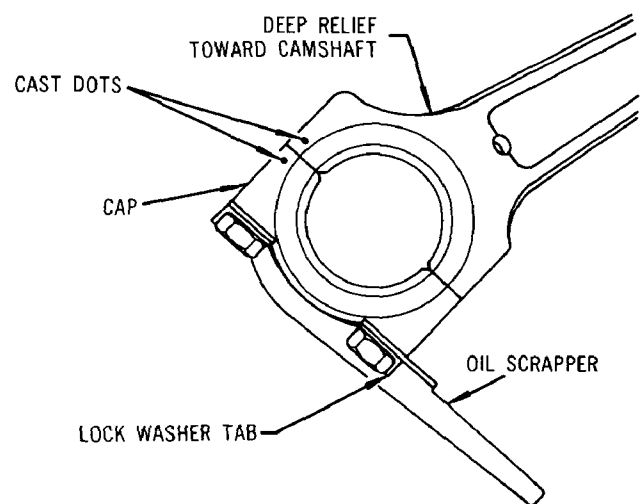

Fig. 6-4-15

- 5) Mount new lock washers and tighten rod bolts to 250~300kg-cm (18~22 ft-lbs) torque.
- 6) Check for free movement of connecting rods by turning crankshaft over slowly. If satisfactory, fold up tabs of lock washers against hexagon flat on connecting rod bolts.

6-4-26 MAIN BEARING COVER

- 1) Unscrew main bearing cover mounting bolts (10mm × 32, 7 pieces) and remove lock washers.
- 2) Evenly tap around the periphery of bearing cover with soft hammer until cover breaks free from crankcase.

** Carefully remove cover so as not to damage oil seal.*

In reassembly;

Apply a thin film of oil to crankcase face to hold gasket in place. Lubricate oil seal and take care not to damage lips when mounting. Tighten mounting bolts to 140~160kg-cm (10~15 ft-lbs) torque.

6-4-27 CAMSHAFT AND TAPPETS

- 1) Push tappets outward to clear cam lobes.
- 2) Tap gear end of camshaft with soft hammer and pull camshaft out through main bearing cover opening in crankcase.
- 3) Withdraw tappets and mark them so that they can be reinstalled in the same holes they are removed from.

Check faces for scuffing and stems for excessive wear. (see 12 CORRECTION TABLE)

In reassembly;

Put tappets back in their corresponding guide holes. This will eliminate unnecessary valve stem grinding for obtaining correct tappet clearance.

CAUTION: MOUNT TAPPET BEFORE INSTALLING CAMSHAFT.

6-4-28 CRANKSHAFT

- 1) Make sure that crankshaft gear key is removed from crankshaft.
- 2) Loosen crankshaft from main bearing by tapping lightly at blower end with soft hammer.

Pull crankshaft out from open end of crankcase.

In reassembly;

Clean crankcase thoroughly. Inspect crank pins for excessive wear, and main bearings and camshaft bearings for possible replacement.

6-4-29 ENGINE BASE

Set engine on main bearing cover. Unscrew mounting bolts (10mm × 42, 6 pieces) and remove base along with oil reservoir.

In reassembly;

Tighten engine base mounting bolts to 297~366kg-cm (21.5~26.5 ft-lbs) torque.

**Be careful not to damage oil pump strainer when mounting engine base.*

6-4-30 OIL PUMP

Unscrew pump bracket mounting screws and remove complete oil pump assembly from inside crankcase. Rotate crankshaft, if counterweights and connecting rods interfere with removal.

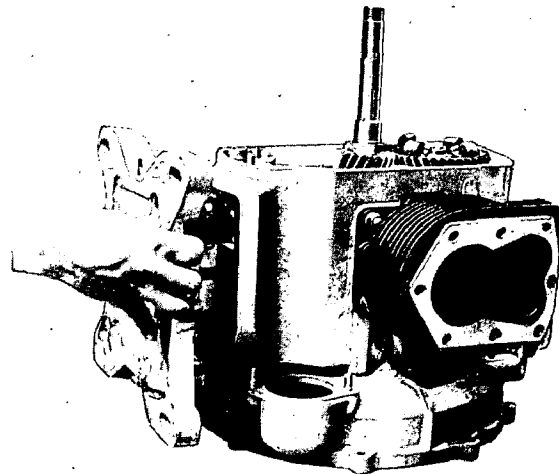

Fig. 6-4-16

In reassembly;

It is necessary that pump body and internal gears be correctly centered after they were removed from adapter, or replaced with a new assembly.

- 1) Place thin transparent gasket onto adapter flange surface. Mount pump body and internal gears to bracket temporarily, tightening four mounting screws in finger tight.
- 2) Insert drive gear shaft into pump bracket, turn drive gear until internal gears become centered and run free.
- 3) Securely tighten four mounting screws and confirm free rotation of gears.
- 4) When mounting oil pump to crankcase, make sure lock screw seats into hole in bracket. Mount gear and shaft per Fig. 6-4-3.

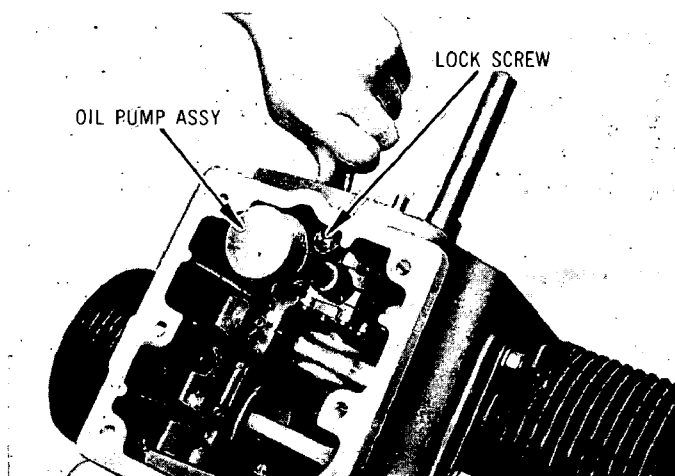

Fig. 6-4-17

6-5 CLUTCH DEVICE

1) LEVER BRACKET

Unscrew mounting bolts (6mm × 14, 3 pieces) and remove lever bracket from bell housing.

2) LEVER

Unscrew bolt to some extent and remove lever from clutch yoke shaft. Bolt need not be unscrewed completely.

3) BELL HOUSING

Unscrew bolts (8mm × 51, 8 pieces) and extract bell housing horizontally out of main bearing cover.

4) PRESSURE PLATE and CLUTCH DISC

Unscrew bolts (8mm × 45, 6 pieces) and remove pressure plate and clutch disc from flywheel.

CAUTION: TAKE CARE TO DISCRIMINATE A ◯ MARK STAMPED BOLT FROM OTHER BOLTS.

5) CLUTCH YOKE BOLTS.

Remove shaft clip, unscrew clutch yoke bolts (8mm × 30, 2 pieces) and extract clutch yoke shaft from bell housing by tapping lightly with soft hammer.

6) CLUTCH YOKE and CARBON BEARING

Remove clutch yoke and carbon bearing.

7) OIL SEAL RETAINER

Unscrew mounting bolts (6mm × 16, 4 pieces) and remove oil seal retainer from bell housing.

8) CLUTCH SHAFT

Remove clutch shaft from bell housing by tapping lightly with soft hammer.

In reassembly;

- 1) Take care not to fold oil seal when installing. Take special care not to fold oil seal for bearing guide.
- 2) Mount clutch disc and pressure plate on flywheel, taking care to locate the clutch disc spring concentrically with the crankshaft needle bearing. (use clutch mounting guide mandrel)
- 3) Screw ◯ marked bolt in ◯ marked screw hole in flywheel after putting it through ◯ marked hole in clutch cover.
- 4) Clamp clutch lever and clutch yoke shaft together after aligning slit in clutch lever boss and slit in clutch yoke shaft.

- 5) Fill needle bearing at crankshaft end with bearing grease amply. If bearing is overfilled, grease may thrown out during operation and contaminate lining to cause slip.

Fill ball bearing that supports clutch shaft with the same bearing grease until grease become flush with the side of bearing. Do not use conventional grease but use special bearing grease based on lithium soap.

6-6 REDUCTION DEVICE

1) OIL DRAIN PLUG

Remove oil drain plug and drain oil.

2) OIL GAUGE

Remove oil gauge from reduction case.

3) REDUCTION CASE COVER

Unscrew mounting bolts (8mm × 38, 8 pieces) and remove reduction case with Puller tool .

** In this case, remove only reduction case cover, and leave reduction shaft in case.*

4) DRIVING SPROCKET and SPACER

a) Disconnect chain at connecting link by removing connecting clip, and remove chain from driving sprocket.

b) Unscrew bolt (10mm × 22, 1 piece), remove washer for pulley and remove driving sprocket from driving shaft by tapping with aluminum bar and soft hammer.

c) Remove adjusting collers from shaft.

** Take careful note of the number of adjusting collers.*

d) Remove key and remove spacer from shaft.

5) CHAIN

Remove chain by turning reduction shaft by hand.

6) REDUCTION SHAFT

Extract reduction shaft along with sprocket ball bearing from redcution case, by tapping lightly with soft hammer.

7) Unscrew mounting bolts (8mm × 26, 8 pieces) and remove reduction case from mounting flange.

8) MOUNTING FLANGE

Unscrew mounting bolts (8mm × 51, 8 pieces) and remove mounting flange from main bearing cover.

In reassembly;

1) Bring front face of driving sprocket flush with front face of reduction case by adjusting with adjusting collers.

2) Install chain connecting clip securely, and first pass chain over driving and driven sprockets and then, mount sprockets on shafts.

6-7 CLUTCH AND REDUCTION DEVICE

First disassemble reduction device and then disassemble clutch device. For detailed procedures, refer to “6-5 CLUTCH DEVICE” and “6-6 REDUCTION DEVICE”.

NOTE: Ball bearings on clutch shaft are lubricated by oil in reduction case. No grease is necessary. Give grease only to needle bearing at crankshaft end.

7. ELECTRICAL EQUIPMENT

7-1 AC ALTERNATOR (for Model EY21AS)

The AC alternator provides electrical energy for the ignition system, battery, and a 35W lamp. The alternator circuit is rated at 12V. There are no maintenance or adjustment requirements because there is no brush, commutator, or belt. The stator and magnetic rotor are mounted within the blower, sealed off from moisture and dirt. A selenium rectifier converts the charge for the battery, from alternating current to direct current.

CAUTION:

- 1) DO NOT REVERSE BATTERY CONNECTIONS. THIS IS FOR NEGATIVE GROUND SYSTEM ONLY.
- 2) CONNECT BOOSTER BATTERIES PROPERLY—POSITIVE TO POSITIVE AND NEGATIVE TO NEGATIVE.
- 3) DO NOT POLARIZE ALTERNATOR.
- 4) DO NOT GROUND ANY WIRES FROM STATOR OR RECTIFIER THAT TERMINATE AT CONNECTORS.
- 5) DO NOT OPERATE ENGINE WITH BATTERY DISCONNECTED.
- 6) DISCONNECT AT LEAST ONE BATTERY LEAD IF A BATTERY CHARGER IS USED.
- 7) NEVER USE A FAST BATTERY CHARGER TO BOOST THE BATTERY OUTPUT.

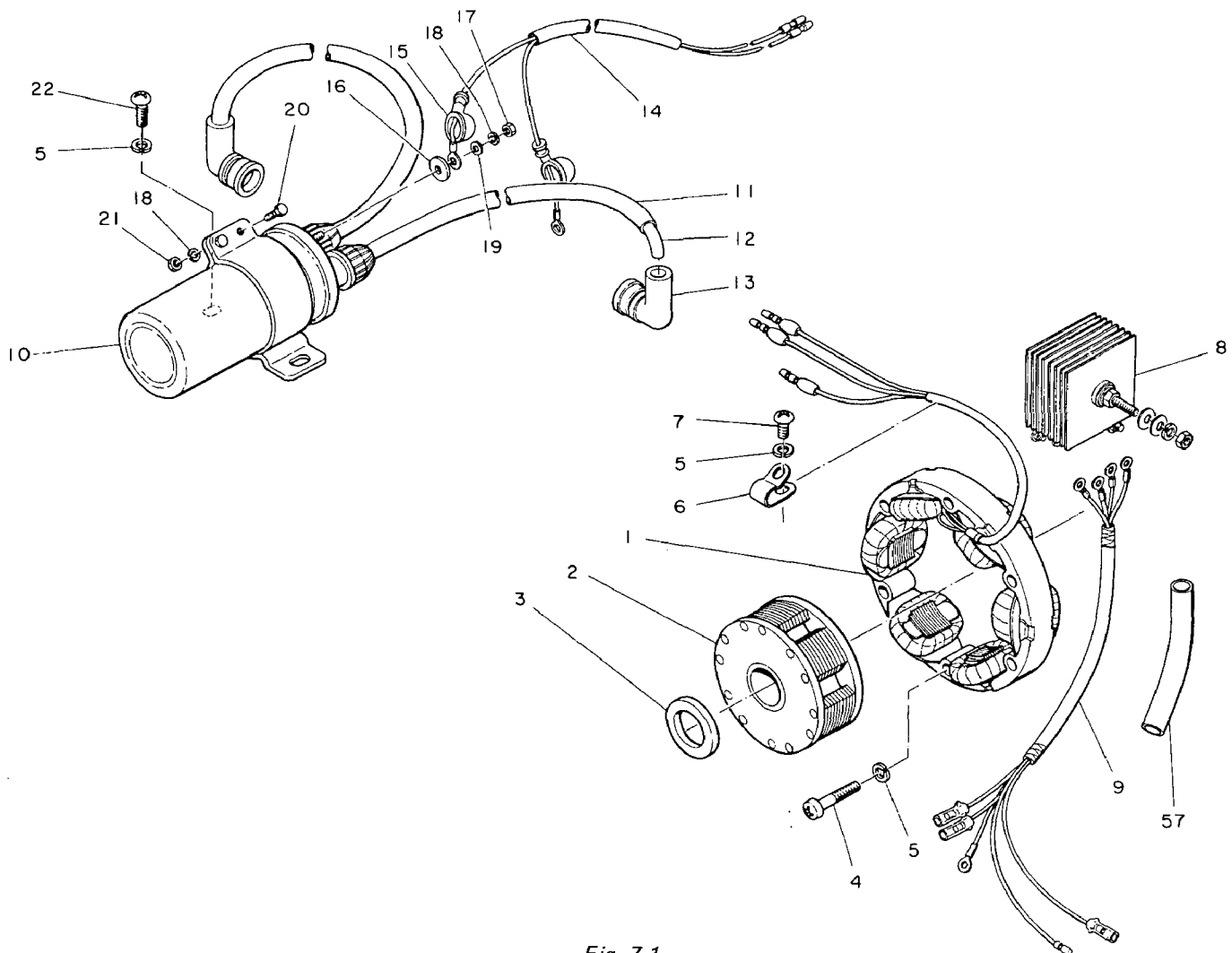

Fig. 7-1

7-2 STARTING MOTOR (for Model EY21AS)

The starting motor assembly consists of a motor section, including a stator, rotor, clutch and gear, and a magnetic switch section. When the starter button is depressed, the magnetic switch is actuated to energize the motor circuit and at the same time, the clutch shift lever is actuated to engage the clutch, so that as soon as the motor shaft starts to rotate, this rotation is transmitted over a flywheel ring gear to the crankshaft to start the engine.

When the starter button is released, the motor circuit is deenergized and simultaneously the clutch is disengaged to free the motor from the engine revolution.

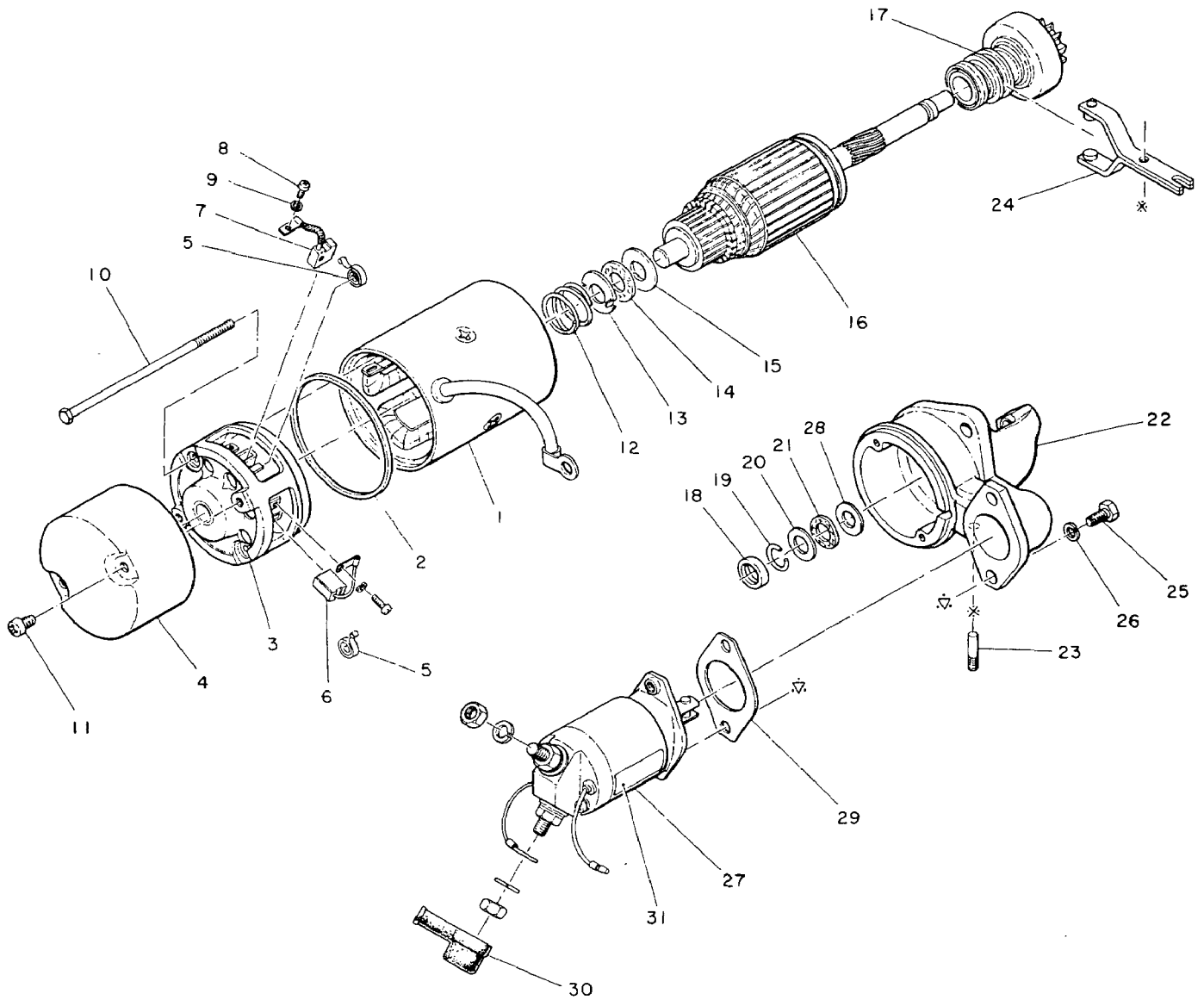

Fig. 7-2

CAUTION: DO NOT KEEP START BUTTON DEPRESSED OVER FIVE SECONDS. IF ENGINE FAILED TO START AT THE FIRST ATTEMPT, REPEAT AGAIN AFTER PAUSING FOR 10 SECONDS. REPLACE MOTOR BRUSHES WHEN THEY ARE WORN. AS POSITIVE BRUSH AND NEGATIVE BRUSH ARE DIFFERENT, TAKE CARE NOT TO CONFUSE THEM.

7-3 MAGNETO (for Model EY21B)

In model EY21B engines, the ignition spark is furnished by a magneto. The magneto is composed of a stator and an ignition coil (including condenser) mounted on the gear case cover and a rotor mounted on the crankshaft.

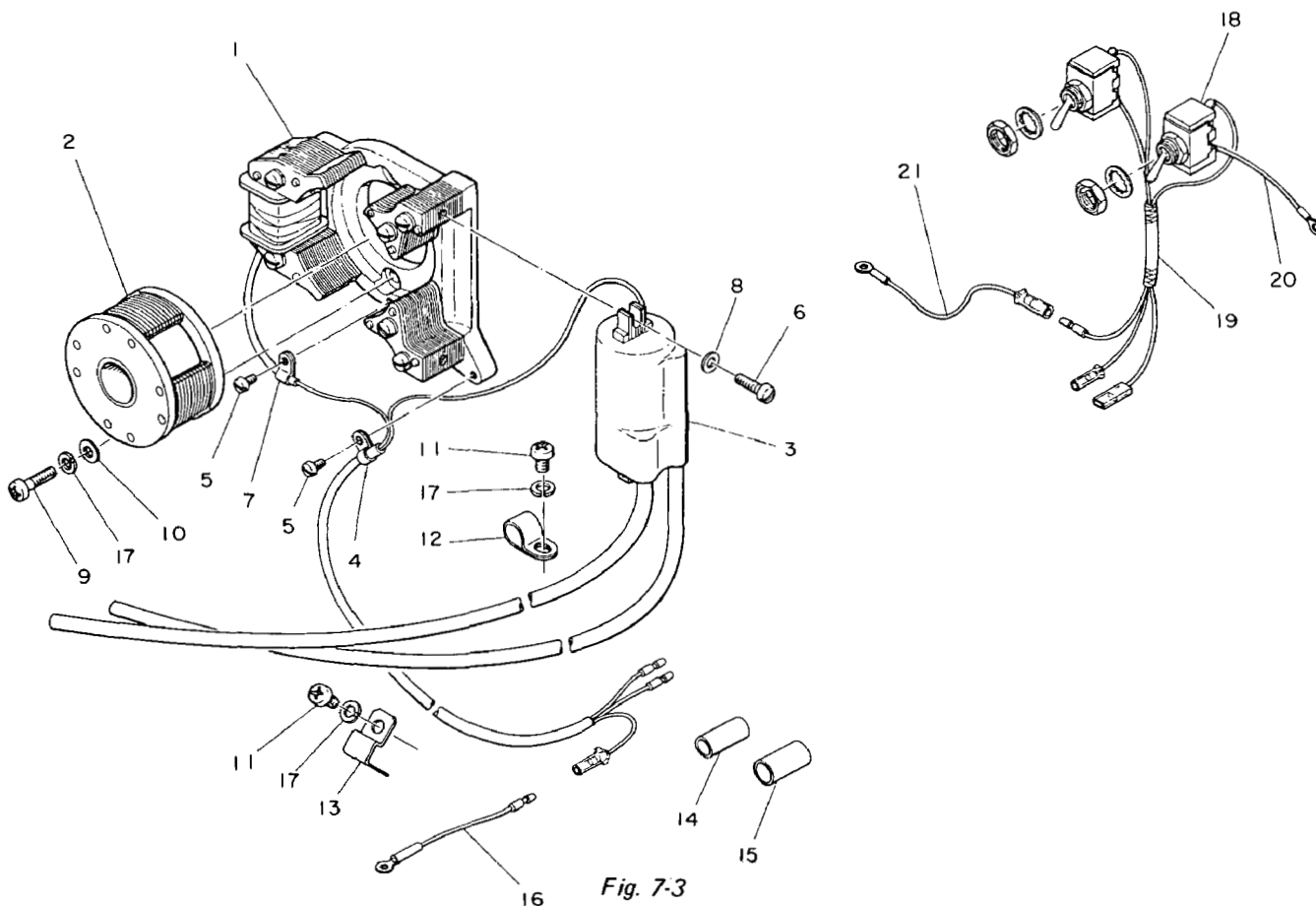

Fig. 7-3

7-4 BREAKER POINT ADJUSTMENT

The breaker points in the contact breaker should be checked whenever the ignition spark becomes weak. If there is evidence of pitting or pyramiding and replacement of the points is necessary, an adjustment of the gap to its proper dimension is also necessary.

The normal breaker point opening is 0.35mm (0.014 inch) at full separation. Because any change in gap opening will affect the ignition advance, set the gap before adjusting timing.

Referring to Fig. 7-4, adjust breaker point gap as follows, and then proceed with instructions in "7-5 TIMING ADJUSTMENT".

- 1) Remove breaker cover from contact breaker.

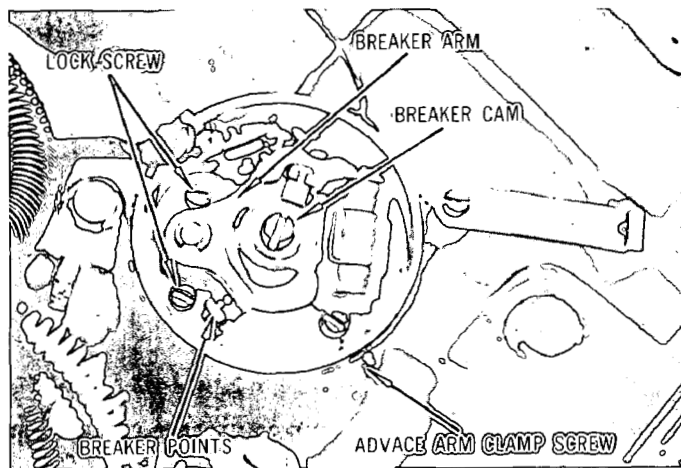

Fig. 7-4

- 2) Turn crankshaft over until breaker arm comes in contact with either of the high points of the breaker cam. (maximum point opening).
- 3) Loosen two contact support plate lock screws just enough to allow movement of plate.
- 4) Insert 0.35mm (0.014 inch) feeler gauge between the points.
- 5) Apply a screw driver to adjusting tab and move contact support plate just enough to bring the points to such an opening that a slight drag is felt while sliding the feeler gauge between them.
- 6) Tighten lock screws and recheck breaker point gap.
- 7) Pull a strip of 8~10mm wide white paper through the closed points to remove oil and sust.

7-5 TIMING ADJUSTMENT

The static timing is 8° before the TDC. This spark advance of 8° is obtained when the breaker point opening is adjusted according to Section "7-4 BREAKER POINT ADJUSTMENT".

The breaker cam which rotates at half the engine speed is equipped with an automatic spark advancer. The advance starts at a crankshaft speed of 600 rpm, and continues on to a maximum running spark advance of 18° before the TDC at 2000 rpm and over.

The advance timing is more accurately adjusted through the following procedures using a timing light as shown in Fig.7-5-1.

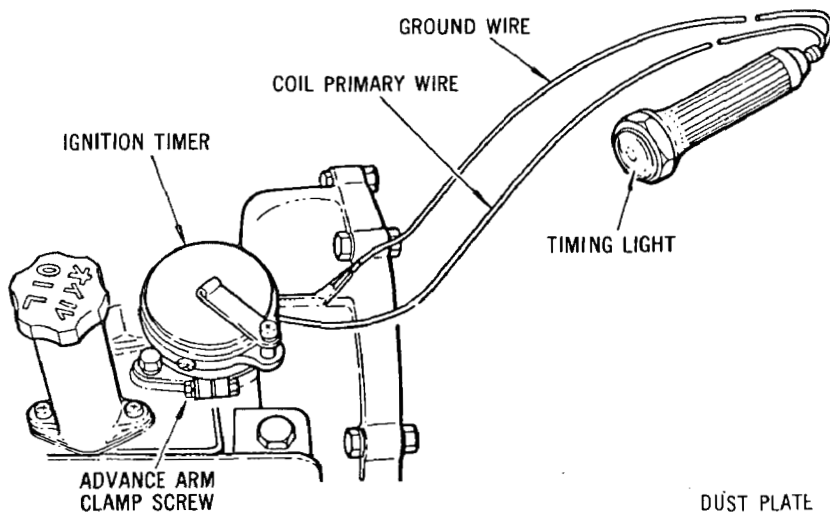

Fig. 7-5-1

For timing adjustment, the following alignment marks are provided: (see Fig. 7-5-2)

- ▲ mark on blower housing
- timing hole in dust plate

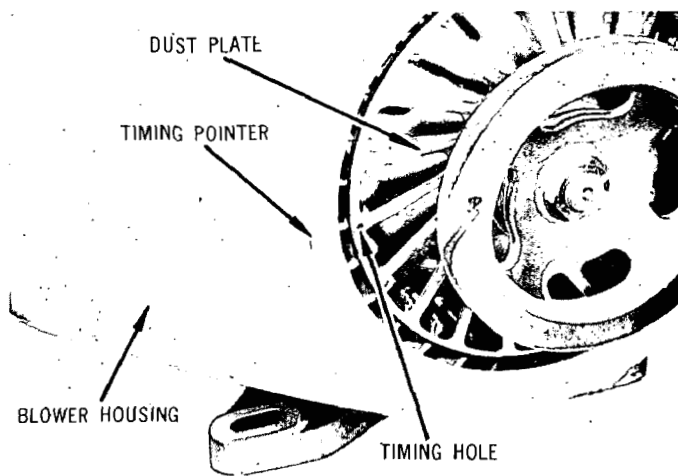

Fig. 7-5-2

- 1) Remove spark plugs for ease in turning engine over and aligning timing marks.
- 2) Disconnect primary wire connector at ignition timer and connect one lead wire of timing light to the wire leading from the timer.
Connect other lead wire of timing light to a convenient ground location on the engine.
- 3) Turn engine over slowly with the rope pulley in the clockwise direction, until the timing hole in the dust plate lines up with the ▲ mark on the blower housing. See Fig. 7-5-2. If the timing light just went out (or on, if an alternate type light is used) as the two timing marks came into alignment, one of the two cylinders is in correct timing.
- 4) If the timing light goes out before or after the timing marks line up, align the timing marks and slightly loosen the ignition timer advance arm clamp screw, shown in Fig. 7-4. Turn the timer body slowly clockwise or counter-clockwise until the breaker points are just beginning to open and the timing light just goes out. Tighten clamp screw. See Fig. 7-4.
- 5) Leave the timing light connected and turn the rope pulley one complete revolution, in the clockwise direction, to check the ignition timing of the other cylinder. If timing is not exact, and light goes out within 2° (about 1/8 inch) above or below the timing mark, timing is satisfactory.
- 6) If there is a considerable difference between the two cylinders—more than $\pm 2^\circ$ —mark the blower housing so that the difference can be split between the two cylinders. Revert back to paragraph 4) and change the timing of the first cylinder by one-half the distance from the mark made on blower housing to the pointer, i.e.—if 2nd cylinder is retarded by 4° (about 1/4 inch), set ignition timing so that the first cylinder is advanced by 2° —the 2nd cylinder should then be retarded by only 2° .
- 7) Connect primary wire and mount ignition timer cover.

7-6 SPARK TESTING

If difficulty is experienced in starting the engine or if engine misfires, the strength of the ignition spark should be checked: Remove spark plug from one of the cylinders—then with the ignition cable connected to it, lay the spark plug on a convenient metal part of the engine so that the gap can be observed as you rotate the crankshaft several times by the rope starter. Repeat this operation with the spark plug and ignition cable of the other cylinder. If good strong sparks occur, the ignition system can be eliminated as the source of trouble. If there are weak sparks or no spark at all, refer to the Sections, “7-4 BREAKER POINT ADJUSTMENT” and “7-5 TIMING ADJUSTMENT”.

Be sure that spark plugs are in good condition and correctly gapped, when making this check.

7-7 BATTERY (for Model EY21AS)

7-7-1 BATTERY CAPACITY

Prepare a battery of the following capacity: 12V, 24AH

7-7-2 CHARGING

Charge selection switch should be set at the “LOW” position for normal operation with accessory lamp off.

When a quick battery charge is required, set charge select switch to “HIGH” position and disconnect accessory lamp. DO NOT overcharge—when bubbles appear in the electrolyte, set charge select switch back to “LOW” position. If accessory lamp is used, connect lamp back into circuit and operate switch in “HIGH” position.

7-7-3 CAUTIONS IN OPERATION

Check electrolyte level once a month and give the following treatment according to need:

- 1) Add distilled water, if electrolyte level is found below specified position. When distilled water is not available, cooled boiled drinking water may be used as an emergency replacement.
Add up each cell individually.
- 2) The battery exterior is liable to be soiled. Keep it clean by wiping with dry cloth from time to time.
Especially maintain the terminals clean, and apply grease to protect them from rusting.
- 3) Even when the engine is not operated, the battery discharges steadily through self-discharge. When the engine is stored long, keep the battery charged by charging it monthly to maintain the engine ready for operation all the time.
- 4) If the starting motor does not run at all or runs with a hitch, this is due to over-discharge of the battery. Charge it immediately, or it will be deteriorated beyond recovery.

8. GOVERNOR

8-1 GOVERNOR LINKAGE

No particular governor adjustment is required other than properly mounting the control linkage and regulating the speed for continuous engine operation. A slotted hole in the governor lever-link assembly, that fits on to a flat on the governor shaft, eliminates any need for throttle linkage adjustment. Thus, the ratio of carburetor throttle opening to governor lever travel is automatically obtained.

Mount and hook up governor linkage per Fig. 8-1, then adjust engine operating speed per Speed Regulation, Fig. 8-2.

8-2.

8-2 GOVERNOR ADJUSTMENT

The governed operating speed is obtained by hooking the governor spring into the correct hole of the governor lever-link and then regulating the spring tension by means of an adjusting stop screw. The governor lever-link has 3 holes for hooking the governor spring into, with the No. 1 hole closest to the governor shaft.

To acquire a particular load rpm, as specified in chart in Fig. 8-2, adjust the governor to the NO load rpm (over-run), in the following manner:

Load R.P.M.	No Load R.P.M.	Spring Hole No.
1800	2000	2
2000	2200	2
2200	2390	2
2400	2580	2
2600	2770	2
2800	2960	2
3000	3150	2
3200	3350	2
3400	3540	2
3600	3730	2
3800	3920	2

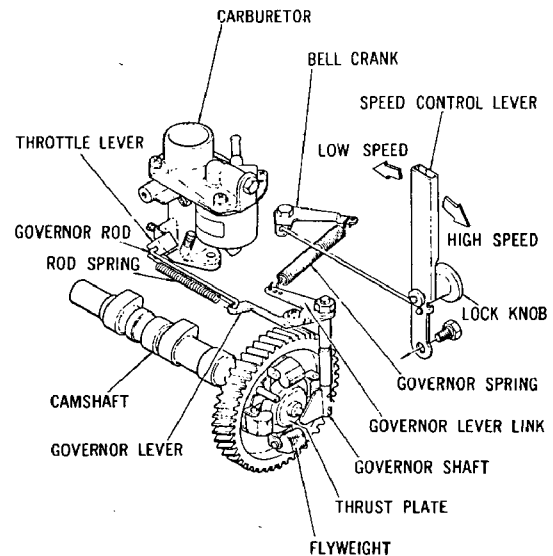

Fig. 8-1

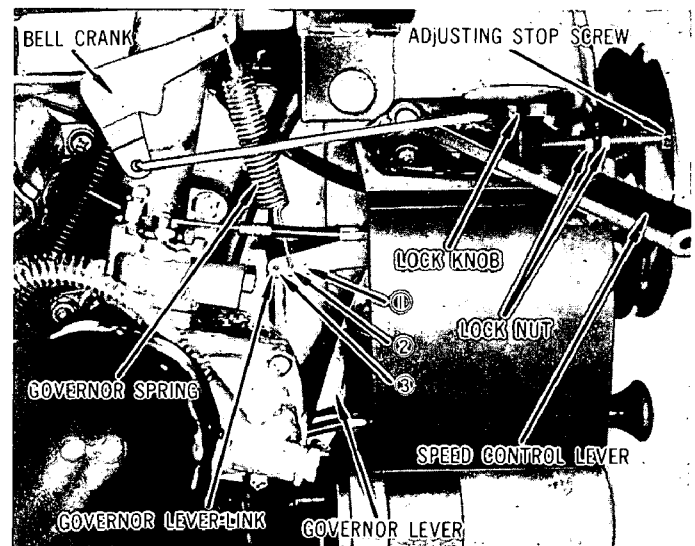

Fig. 8-2

- 1) Hook governor spring from hole in bell crank to the numbered hole in governor lever-link relative to the desired load speed.
- 2) Loosen lock-knob enough so that speed control lever is free to move.
- 3) Loosen lock nuts on the adjusting stop screw.
- 4) While operating engine without load, hold the speed control lever against the adjusting stop screw. Place a tachometer or revolution counter against the end of the crankshaft and regulate the spring tension by turning adjusting stop screw in or out until required no load speed is obtained. Tighten adjusting screw lock nuts.
- 5) Tighten lock knob if engine is to operate at a fixed speed. For remote speed control operation, leave lock knob loosened so that control lever is free to move.

9. CARBURETOR

9-1 OPERATION and CONSTRUCTION

Model EY21AS and EY21B engines are equipped with a down draft carburetor that has a float controlled fuel system and independent starter (choke) system. There is no choke valve in the air intake.

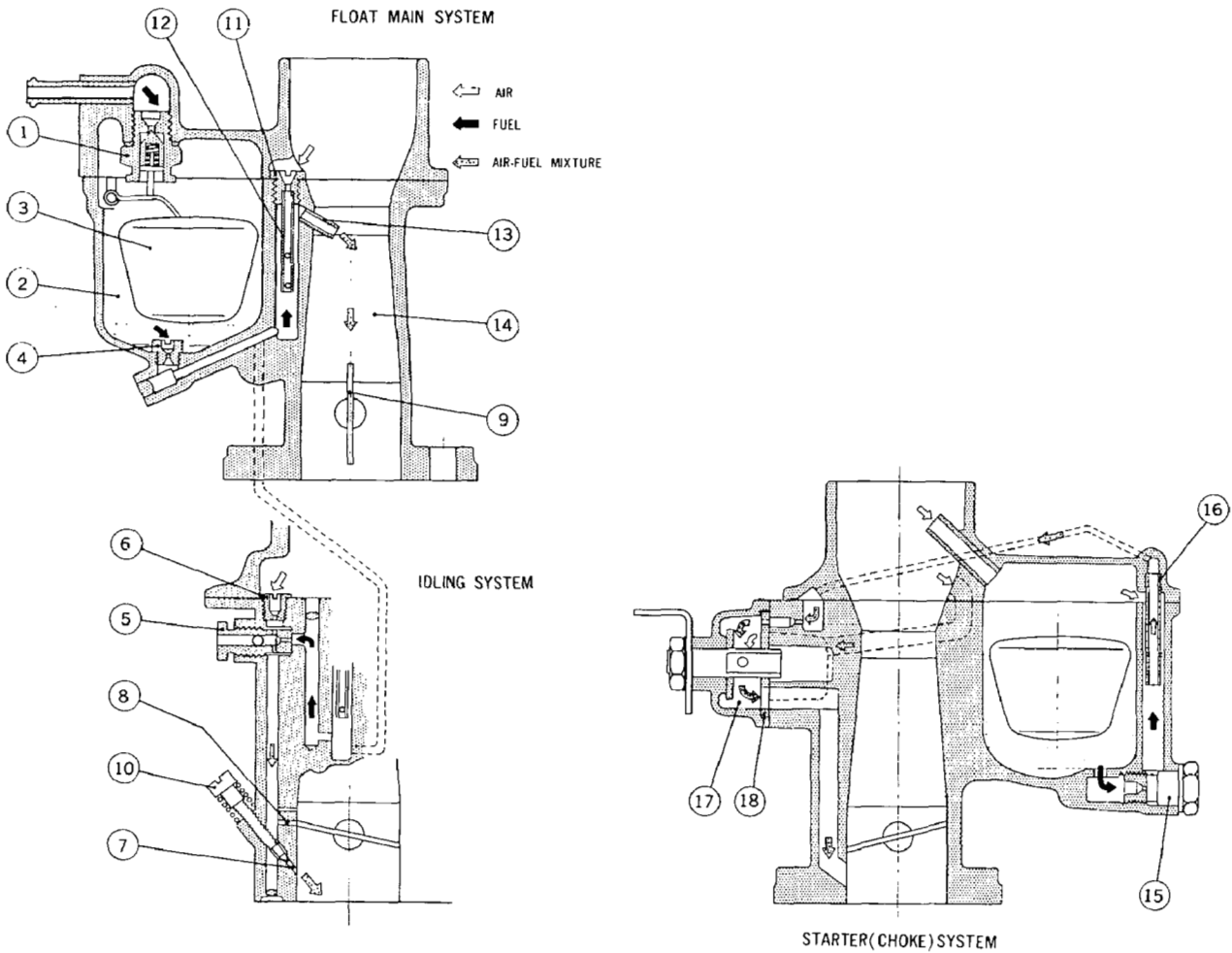

Fig. 9-1-1

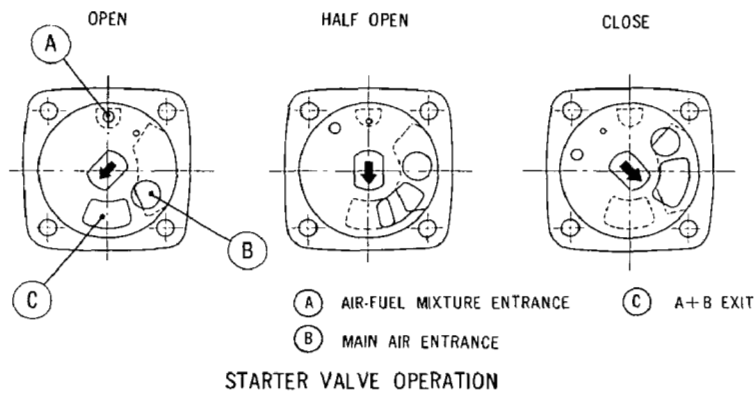

Fig. 9-1-2

9-1-1 FLOAT SYSTEM

Fuel in the fuel tank is pumped by a diaphragm type fuel pump driven by the camshaft into the float chamber through a needle valve.

When the fuel in the float chamber reaches a predetermined level, the float is pushed up so that the needle valve is forced to close against the fuel pressure and to maintain the fuel at a definite level.

When the engine is stopped, the fuel pump is stopped also, and the fuel supply is stopped automatically.

9-1-2 PILOT SYSTEM

The pilot system supplies fuel to the engine during idle and low speed operation. Fuel is taken through the main jet and metered through the pilot jet. The fuel is then mixed and atomized together with air metered through the pilot air jet. This rich mixture is then discharged through the pilot outlet to the intake manifold.

During idle running, air is introduced through the bypass to make the air-fuel mixture lean and to help atomize the fuel. The resulting mixture is regulated in the space between the pilot outlet and the pilot adjusting screw, before being discharged together with a small amount of air into the throttle bore.

When the throttle valve is opened a little more, the bypass is subjected to a negative pressure, allowing a fuel mixture to discharge from the bypass to help meet the demands of the engine.

The pilot adjusting screw controls the ratio of the fuel mixture; the further it is screwed in, the richer the air-fuel mixture becomes.

9-1-3 STARTER SYSTEM (choke)

The fuel system, unlike conventional carburetors, has a special independent starter system. Fuel from the float bowl is metered through the starter jet and is mixed with air introduced through the air vent inside the starter bleed tube. The mixture then flows into the starter valve where additional air from the main air intake maintains a correct air-fuel ratio for easy starting.

9-1-4 MAIN SYSTEM (high speed)

The main system controls the air-fuel mixture during medium and high speed operation, as well as during heavy load and acceleration when high power output is required.

Fuel from the float chamber is metered through the main jet and is mixed with air from the main air jet. The mixture is then atomized in the main air bleed, and discharged into the throttle bore through the main nozzle. Here the atomized fuel is further mixed with air from the air cleaner to produce the correct air-fuel mixture for efficient engine operation.

9-2 DISASSEMBLY AND REASSEMBLY

Besides mechanical failures, most troubles are attributed to an incorrect mixing ratio. The most common causes of incorrect fuel-air mixtures are clogged jets, restricted air and fuel passages, and variations in the fuel level. In order to obtain the full performance of the carburetor, the air cleaner and carburetor must be maintained clean so that air and fuel flow without restriction. A regular grade of good fresh gasoline will help keep the carburetor clean. (see Fig. 9-2-1)

9-2-1 CLEANING

Thoroughly clean all metal parts in fuel (gasoline) and rinse in cleaning solvent. Blow out all passages in throttle body and float chamber with reduced air pressure. Be sure all carbon deposits have been removed from throttle bore and idle discharge holes. Reverse the flow of compressed air through all passages to insure the removal of all dirt.

CAUTION: NEVER USE A DRILL OR METAL WIRE TO CLEAN JETS. THEY ARE LIABLE TO DAMAGE THE ORIFICE AND CAUSE AN ENGINE MALFUNCTION. BLOW AIR TO CLEAN THEM.

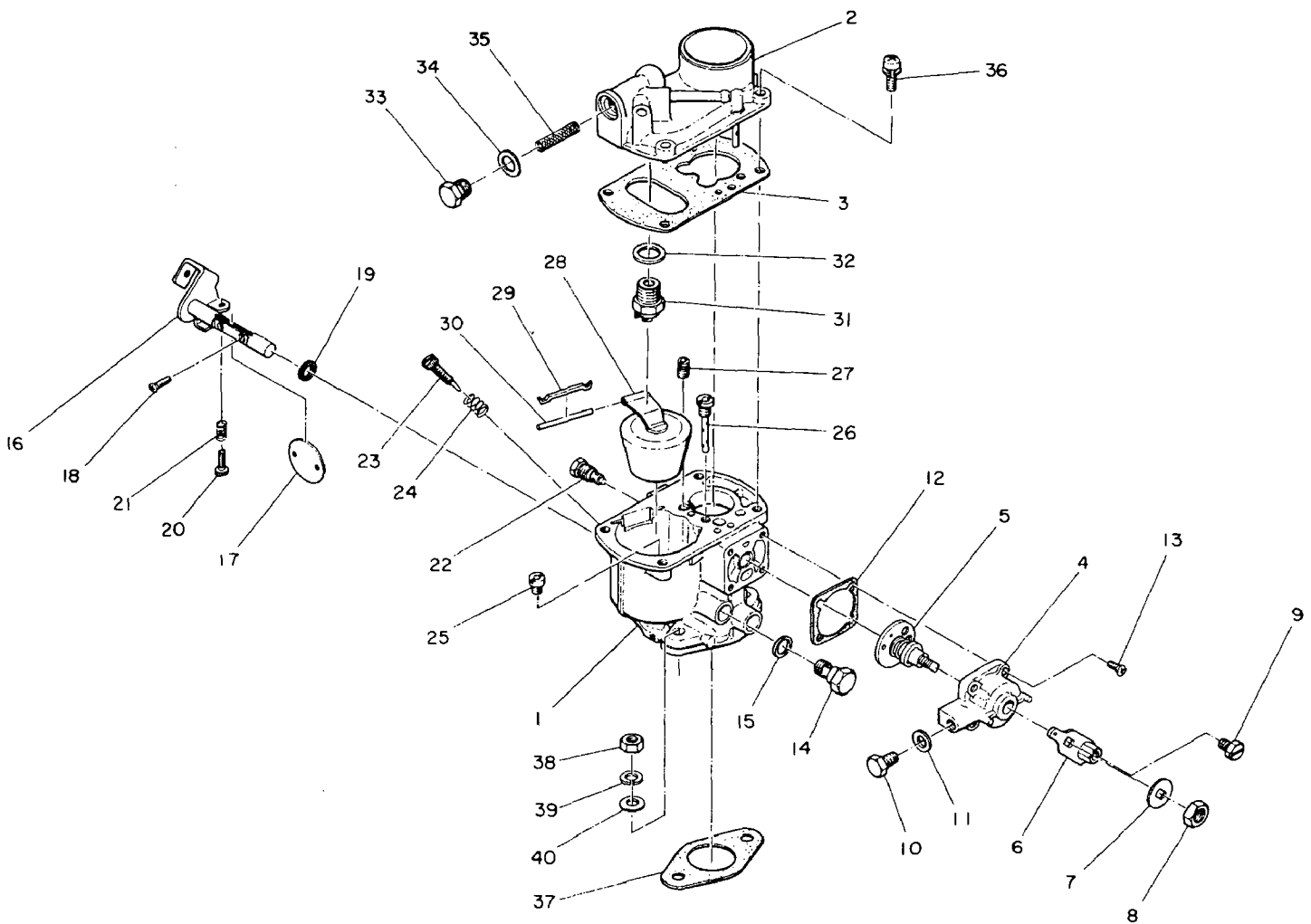

Fig. 9-2-1

9-2-2 FLOAT SYSTEM

- 1) Unscrew screw (36), remove upper body (2), and remove float (28), spindle (30), and stopper (29).
- 2) Remove needle valve (31) from upper body (2).

In reassembly;

- 1) Check float with a depth gauge and if necessary, bend float lever to obtain the setting indicated in Fig. 9-2-2. When bending, be sure the top of lever that contacts the fuel valve remains flat and parallel.

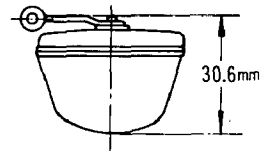

Fig. 9-2-2

- 2) Install spindle stopper (29) into recess in lower body (1) with the offset ends of the stopper against the exposed ends of the spindle (30). The middle section of the retainer will be away from the float arm, allowing it to operate freely.

CAUTION: IF STOPPER IS REVERSED, MIDDLE SECTION WILL PRESS AGAINST SPINDLE, PREVENT FUEL LEVEL CONTROL, AND CAUSE FLOODING.

- 3) Replace needle valve (31) as a needle valve and seat assembly.

9-2-3 THROTTLE SYSTEM

- 1) Unscrew screw (18), remove throttle valve (17), and extract throttle shaft (16).

Take care not to damage ends of throttle valve.

- 2) Unscrew throttle stop screw (20) to remove spring (21).

In reassembly;

Make sure that throttle shaft turns freely and does not bind. Set throttle stop screw per instructions in "9-3 ADJUSTMENTS".

9-2-4 STARTER SYSTEM

- 1) Unscrew nut (8) and remove lever (6) and washer (7).
- 2) Unscrew screw (13), and remove starter valve body (4) along with valve (5) from lower body (1).

In reassembly;

Replace packing (12) with a new one.

Turn valve shaft so that arrow on end of shaft points down, and mount lever with control wire swivel block in the same direction (down). See starter valve illustration, Fig. 9-1-2. After tightening shaft nut, fold washer over hexagon flat of nut.

9-2-5 PILOT SYSTEM

- 1) Remove pilot jet (22). Use correct tool to prevent damage.
- 2) Unscrew pilot screw (23) and remove spring (24).

In reassembly;

- 1) Tighten pilot jet firmly to prevent fuel leakage and a possible poor engine performance.
- 2) Replace pilot screw if tapered end is deformed. Do not overtighten.

9-2-6 MAIN SYSTEM

Remove main jet (25) and main air jet (26). Use correct tool to prevent damage.

In reassembly;

Tighten main jet securely. If not tightened securely, an engine disorder may result through a too rich fuel mixture.

9-3 ADJUSTMENTS

The idle adjustment should be made after the engine has been sufficiently warmed up.

** Initial Settings*

- 1) Gently seat the pilot adjusting screw and then back screw out (counter-clockwise) about one turn.

CAUTION: DO NOT SEAT PILOT SCREW TOO FIRMLY – THIS MAY DAMAGE THE NEEDLE POINT AND PREVENT A SATISFACTORY ADJUSTMENT.

- 2) Turn throttle stop screw clockwise, until it just contacts the stop lug when throttle valve is fully closed – then turn screw two full turns.

CAUTION: DO NOT OVERTIGHTEN PILOT SCREW WHEN CLOSING IT FULLY. THE NEEDLE POINT MIGHT BE DAMAGED BY OVERTIGHTENING.

** After Engine is Warmed Up*

- 1) With engine running, turn pilot adjusting screw in or out until the engine runs evenly just before slowing down.
- 2) Turn throttle stop screw slightly to obtain an idle speed of about 1000 rpm.
- 3) Make slight adjustments with both the pilot adjusting screw and throttle stop screw until a smooth idle speed of 1000 rpm is obtained, with air cleaner mounted and engine running at normal operating temperature.

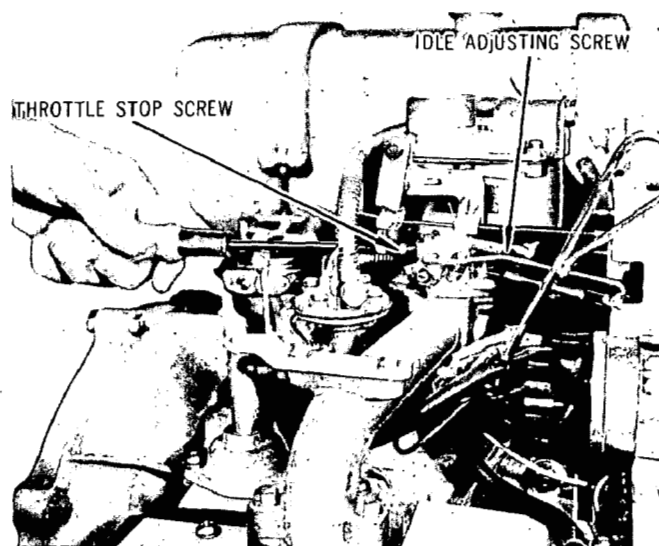

Fig. 9-3

10. RUN-IN OPERATION OF REASSEMBLED ENGINE

An engine that has been completely overhauled by having the cylinders rebored and fitted with new pistons, rings, valves and connecting rods should be thoroughly "RUN-IN" before being put back into service.

Good bearing surfaces and running clearances between the various parts can only be established by operating the engine under reduced speeds and loads for a short period of time.

LOAD	SPEED	TIME
No load	2500 r.p.m.	10 minutes
No load	3000 r.p.m.	10 minutes
No load	3600 r.p.m.	10 minutes
6 h.p.	3600 r.p.m.	30 minutes
12 h.p.	3600 r.p.m.	60 minutes

While engine is being tested – check for oil leaks.

Make final carburetor adjustments and regulate the engine operating speed.

11. TROUBLE SHOOTING

For a gasoline engine to start and run satisfactorily, the following three requirements must be met:

- 1) The cylinder filled with a proper fuel-air mixture.
- 2) An appropriate compression in the cylinder.
- 3) Good sparks at correct time to ignite the mixture.

If all the three requirements are not met simultaneously, an engine can not be started. There are also other factors such as a heavy load at starting and too long an exhaust pipe causing a high back pressure, which contribute to hard starting. The most common causes of engine troubles are given below:

11-1 STARTING DIFFICULTIES

11-1-1 STARTER

The starter does not run smoothly or does not run at all. (Model EY21AS)

Cause	Remedy	Preventive measure
Run down battery	<ol style="list-style-type: none"> 1) Charge battery if over-discharged. Start engine with rope, and run engine with light switch turned to LIGHTING position but without lighting, to charge quickly. Take care not to over-charge. 2) If battery is defective, repair or replace. 	<ol style="list-style-type: none"> 1) Do not leave engine switch at RUN position while engine is standing still. During storage, charge battery once a month. Also check for loss of magnetism in AC generator, breakdown of selenium rectifier, and failure of charging circuit. 2) Never let electrodes be exposed above electrolyte. Add up distilled water.
Defects in switch or circuit wire	<ol style="list-style-type: none"> 1) Replace defective switch. 2) Repair or replace defective circuit wire. 	
Defects in starter itself	Replace defective starter.	

11-1-2 FUEL SYSTEM

Cause	Remedy	Preventive measure
Defects in fuel tank system	<ol style="list-style-type: none"> 1) Clean clogged tank outlet. 2) Clean clogged fuel strainer. 3) If incorrect fuel is poured into tank or water is mixed, drain tank completely and fill it with correct fuel. 4) When fuel pipe is locked with air, expell air. 	<ol style="list-style-type: none"> 1) Be sure to use a filter when adding fuel. 2) Use automobile gasoline as fuel.
Defects in fuel pump or carburetor	<ol style="list-style-type: none"> 1) If clogged with dust, clean. 2) If defective, replace. Clean jets and other orifices if they are clogged. 	

11-1-3 COMPRESSION SYSTEM

Cause	Remedy	Preventive measure
Gas leak through head gasket or other parts	<ol style="list-style-type: none"> 1) If head gasket is defective, replace. 2) If head bolts are loose, tighten. 3) If spark plugs are loose, tighten. 4) If spark plugs are defective, replace. 	
Defects in intake or exhaust valve	<ol style="list-style-type: none"> 1) If valve seating is not snug, lap. 2) If foreign matter (mostly carbon) is deposited on valve seat, remove it and adjust tappet clearance. 3) If valve is stuck in valve guide, clean valve and valve guide. 4) If valve is pushed up, grind valve stem end and adjust tappet clearance to 0.15~0.2mm. 5) If valve spring is broken, replace. 	<p>Do not use poor grade oil. Change oil regularly.</p>
Defects in piston assembly	<ol style="list-style-type: none"> 1) If piston is worn, replace. 2) If cylinder is worn, re-bore and use oversize piston rings. 3) If piston rings are worn, replace. 4) If piston rings are stuck, clean or replace rings. 	<ol style="list-style-type: none"> 1) Keep air cleaner always clean. 2) Do not use poor grade oil. Change oil regularly.

11-1-4 ELECTRIC SYSTEM

Cause	Remedy	Preventive measure
Defects in ignition coil (EY21AS)	If wire or insulation is broken, replace coil.	Do not leave engine switch at start position long, while engine is standing still, as coil is burned by this.
Defects in magneto (EY21B)	<ol style="list-style-type: none"> 1) If wire or insulation is broken, replace magneto. 2) If magnetism is weak, re-magnetize (at the magneto maker) or replace. 	
Defects in spark plug	<ol style="list-style-type: none"> 1) If contaminated, wash in gasoline, remove foreign material and dry. 2) If spark plug is broken and lost insulation, replace plug. 3) Adjust spark gap to 0.5–0.6mm. 	<ol style="list-style-type: none"> 1) Use spark plugs of specified heat range. Do not use poor grade oil. Clean air cleaner and avoid dust entry. 2) When spark gap is adjusted, if center electrode is hit or bent, insulator may get damaged.

Cause	Remedy	Preventive measure
Defects in high-voltage cable	1) If cable is burnt, replace (EY21AS) 2) If cable is burnt, replace cable along with coil. (EY21B)	Take care not to let cable come in contact with exhaust pipe and muffler.
Defects in contact breaker	1) If breaker points are rough, smooth out surface with emery paper (#400). 2) If breaker point gap is incorrect, adjust it to specified 0.35 ± 0.05 mm by loosening contact support plate lock screws. 3) If spark timing is incorrect, adjust it to 8° before TDC. 4) If breaker is defective in insulation, replace breaker. 5) If condenser is defective, replace.	

11-1-5 OTHER CAUSES

Cause	Remedy	Preventive measure
Improper oil Too heavy load	Change oil according to seasons. If belt is too tight, correct tension. If load is still too heavy, use clutched engine.	
Too much resistance in starting	Piston or connecting rod seized	Do not use poor grade oil.
	Clutch not disengaging perfectly.	

11-2 IDLING OUT OF ORDER

- 1) If the pilot adjusting screw in the carburetor is incorrectly adjusted, readjust by backing off one full turn from fully closed position.
- 2) All the causes for starting difficulty are also causes for idling disorder.

11-3 OVERHEAT and NOCKING

- 1) If ignition timing is too far advanced, readjust.
- 2) If carbon deposit is excessive in combustion chamber, Remove.
- 3) If spark plug heat is range too low, replace with correct plug.
- 4) If fuel air mixture is too lean, clean jets and orifices in carburetor.

- 5) If air leak is in suction system, replace parts or tighten junctions.
- 6) If engine is overloaded, reduce load below cruising load.

11-4 ENGINE POWER LOST

- 1) If the cylinders, pistons and/or piston rings are worn, replace them, or rebore cylinders and install oversize piston rings.
If piston rings are stuck, clean them.
- 2) If the carburetor is out of order, readjust it or clean it.
- 3) If the fuel pump is out of order, clean it or replace it.
- 4) If there is a leakage in the suction system, replace defective parts or tighten junctions.
- 5) If the spark plugs are defective (contamination, gas leak, poor insulation), clean or replace.
- 6) If the valves do not seat snugly in the valve seats, lap.
- 7) If the ignition coil (EY21AS)/magneto (EY21B) and/or contact breaker are defective, replace or readjust.
- 8) If the air cleaner is clogged, clean.

11-5 EXCESSIVE FUEL CONSUMPTION

- 1) If the fuel-air mixture is too rich, clean the jets and orifices in the carburetor.
- 2) If the throttle shaft in the carburetor is worn, replace it.
- 3) If fuel leaks, tighten fuel system junctions or replace defective parts.
- 4) Fuel consumption increases also when the output is lost. Perform measures given in 11.4.

11-6 EXCESSIVE OIL CONSUMPTION

- 1) If the crankcase is overfilled with oil, reduce to the specified volume.
- 2) If the piston rings are worn, broken or defective in sealing, replace.
- 3) If the piston rings are stuck, clean or replace.
- 4) If the slots in oil rings or orifices in pistons are clogged, clean.
- 5) If the cylinders are worn or scored, replace or rebore.
- 6) If the gas vent does not operate properly, correct or replace.
- 7) If oil leaks, tighten the leaking joints or replace defective parts.
- 8) If poor grade oil is used, change with good oil.

11-7 ENGINE HUNTING

- 1) If the governor lever and spring lever are incorrectly adjusted, correct their adjustment.
- 2) If the fuel-air mixture is too lean, clean the carburetor.
- 3) If the pilot screw in the carburetor is incorrectly adjusted, readjust it.
- 4) If the governor spring is deformed permanently, replace it.
- 5) If the thrust plate does not function properly, correct it.
- 6) If the fly plate and thrust plate are worn, replace.
- 7) If the governor shaft does not function properly, correct it.

11-8 CLUTCH and REDUCER OUT OF ORDER

- 1) If the clutch can not be engaged or disengaged by the manipulation of the clutch lever, adjust it according to "6-5 CLUTCH DEVICE".
- 2) If the chain and sprocket are worn, replace.

11-9 OTHER COMPLAINTS

- 1) If fuel overflows, from the carburetor (much fuel flows out of inlet pipe oil discharge), this is due to a faulty float valve function or float function. Replace defective parts or correct them.
- 2) If the engine suddenly stops with abnormal noise, the pistons or the connecting rods assemblies are seized. Correct them or replace them.

12. CHECKS AND CORRECTIONS

After disassembling and cleaning the engine parts, check them, and if necessary, correct them according to the correction table.

The correction table applies whenever engines are repaired. Its contents should be thoroughly understood by those who undertake the repairing.

Its specifications must be abided by to effect correct maintenance.

Below, terms employed in the correction table are explained.

1) CORRECTION

All operations performed on the engine parts for the purpose of improving or recovering the engine performance, consisting of repairs, readjustments, and replacements.

2) STANDARD SIZE

The design dimension of the part without the tolerance.

3) CORRECTION TOLERANCE

The tolerance on the re-finished part dimension or on the readjusted dimension.

4) CORRECTION LIMIT

The limit on the part and adjustment, beyond which any dimensional and functional changes, due to wear, burn, and other causes will adversely affect the normal engine performance.

5) USE LIMIT

The limit, beyond which the part is no longer usable, due to defects in function or strength.

NOTE: All dimensions in the "CORRECTION TABLE" are given in millimeter, except where otherwise specified.

CORRECTION TABLE

ITEM	STANDARD SIZE	CORRECTION		USE LIMIT	REMARKS	TOOL	CORRECTION METHOD	
		TOLERANCE	LIMIT					
Flatness of cylinder head		0.05	0.15			Surface plate, Feeler	Correct	
Cylinder	Bore	75 dia.	+0.030 0	difference between max. and mjn. 0.15	1.15		Cylinder gauge	Boring
	Roundness		0.010					
	Cylindricity		0.015					
	Valve seat contact width		1.2~1.5	2.5			Seat cutter	Correct
	Valve guide I.D.	8 dia.	+0.036~0	0.2	0.2	at middle portion	Cylinder gauge	Replace
Piston	O.D. at skirt, in thrust direction (inch. over size)	Old S.T.D. 74.95 dia. B 75.13 dia. C 75.38 dia. D 75.63 dia. E 75.88 dia. New B 75.20 dia. C 75.45 dia. D 75.70 dia. E 75.95 dia.	0 -0.03	-0.1	-0.1	New type: from Nov. 1971	Micro-meter	Replace
	Width of ring groove	Top 2.5 2nd 2.5 Oil 4.0	+0.025 0	0.15	0.15		Vernier calipers, Cylinder gauge	
	Piston pin hole	18 dia.	-0.004 -0.015	0.035	0.035			
	Clearance between piston and cylinder		0.048~0.108	0.3	0.3	Clearance of between cylinder max. ID and OD at skirt of piston, in thrust direction	Cylinder gauge, Micrometer	
	Clearance between piston ring and ring groove		0.01~ 0.055	0.15	0.15		Feeler gauge	
	Fit between piston & piston pin		0.009T ~0.010L	0.06L	0.06L		Micrometer	
Piston Ring	Ring gap	Top 2nd Oil	0.05~ 0.25	1.0 1.5 1.5	1.0 1.5 1.5	As inserted in cylinder skirt	Feeler gauge	Replace
	Ring width	Top 2.5 2nd 2.5 Oil 4		-0.1	-0.1		Micro-meter	
	Piston pin O.D.	18 dia.	-0.006~ -0.014	-0.04	-0.04		Micro-meter	Replace
Connecting Rod	Large end I.D.	35 dia.	+0.025~0	0.1			Cylinder gauge	Replace or Correct
	Clearance between rod large end I.D. and crankpin		0.05~0.10	0.2			Cylinder gauge, Micro-meter	
	Small end I.D.	18 dia.	+0.03~ +0.02	0.08	0.08		Cylinder gauge	
	Clearance between small end I.D. and piston pin		0.026~0.046	0.12	0.12		Cylinder gauge, Micrometer	

ITEM		STANDARD SIZE	CORRECTION		USE LIMIT	REMARKS	TOOL	CORRECTION METHOD
			TOLERANCE	LIMIT				
Connecting Rod	Large end side clearance		0.2~0.5	1.0	1.0		Feeler gauge	Replace
	Parallelism between large end and small end bores		0.05	0.1	0.1	Measure on test bar (l=50) inserted in small end by dial-gauge.	Test bar	Replace or Correct
	Distance between large end and small end bores	136.5			0.5		Dial indicator	Replace
Crankshaft	Crankpin O.D.	35 dia.		0.15	0.5		Micro-meter	Replace or Correct
	Crankpin O.D. roundness		0.005				Micro-meter Dial indicator	
	Crankpin O.D. cylindricity		0.005					
	Crankpin O.D. parallelism		0.010					
	Crankshaft journal O.D.	Drive S. 35 dia. Mag. S.	+0.010~ -0.005 -0.010~ -0.025	-0.03	-0.03		Micro-meter	Replace
Camshaft	Cam lobe height	34.65		-0.25	-0.25		Micro-meter	Replace
	Journal O.D.	Drive S. 20 dia. Mag. S.	-0.005~ -0.020	0.05	0.05			
Valve spring	Free length	46		-1.5	-1.5		Vernier calipers	Replace
	Squareness			1		For total length	Square	
Intake & Exhaust Valves	Valve stem O.D.	Intake 8 dia. Exhaust 8 dia.	-0.055~ -0.080 -0.090~ -0.110	-0.15	-0.15		Micro-meter	Replace
	Clearance between stem and guide	Intake Exhaust	0.091~0.116 0.126~0.146	0.30	0.30	at middle	Cylinder gauge	
	Tappet clearance		0.15~0.20	0.05~ 0.25			Feeler gauge	Correct
	Clearance between groove and retainer		0.04~0.15	0.5	0.5		Feeler gauge	Replace
	Stem end length	4		-2	-2		Vernier calipers	
Tappet	Total length	87.49		-0.5	-0.5		Cylinder gauge Micrometer	
	Clearance between stem and guide		0.025~0.060	0.2	0.2			
Carburetor	Metering needle unscrew	Fixed	±1/4			26BC1		
	Pilot screw unscrew	1.0	±1/4					
Electric Device	Spark plug	NGK B-4						
	Spark gap		0.5~0.6	1			Feeler gauge	Adjust or Replace
	Spark timing	8° before T.D.C. (static timing)	±3°	±5°		23° (at operation)	Timing tester	Adjust
	Point opening	0.35	±0.05	±0.1			Contact breaker spanner	
Point gap	up 7				at 200 r.p.m.			

ITEM	Hp/rpm	CORRECTION LIMIT	REMARKS
MAX, Output	15/3,600	Below 110% of rated output	
Continuous Rated Output	10/3,000		

ITEM	RATIO	CORRECTION LIMIT	REMARKS
Fuel Consumption	3.8 l/hr	Above 135% standard rating	at continuous rating
Lubricant Consumption	85 cc/hr	200	at continuous rating

ITEM	liter	REMARKS
Specified Lubricant Quantity	2.5	Use the class MM or higher grade Mobile Oil. Below -10°C (14°F) SAE 10W – 30 -10°C (14°F) ~ 20°C (68°F) SAE #20 20°C (68°F) ~ 40°C (104°F) SAE #30
Oil Change		First Time: Change oil after 20 hours operation. Second Time and thereafter: Change oil every 50 hours operation.

ITEM	kg/cm ² /rpm	TOOL	CORRECTION LIMIT
Cylinder Pressure	6/350	Pressure gauge	70% of normal value

ITEM	rpm	TOOL	REMARKS
Min, accelerating revolution	below 1,000	Tachometer	

ITEM	kg – cm	ft – lb	TOOL
Cylinder head clamp bolt	450 ~ 500	32 ~ 36	Torque wrench
Connecting rod bolts	250 ~ 300	18 ~ 22	“
Cylinder clamp nuts	310 ~ 350	22 ~ 25	“
Main bearing cover bolts	140 ~ 160	10 ~ 11	“
Spark plug	320 ~ 370	23 ~ 26	“

13. MAINTENANCE AND STORING

The following maintenance jobs apply when the engine is operated correctly under normal conditions. The indicated maintenance intervals are by no means guarantees for maintenance-free operations during these intervals. For example, if the engine is operated in extremely dusty conditions, the air cleaner should be cleaned every day, instead of every 50 hours.

13-1 DAILY CHECKS AND MAINTENANCE

Checks and maintenance	Reasons for requiring them
Remove dust from whatever parts that accumulated dust.	The governor linkage is especially susceptible to dust.
Check for external oil leakage. If any, re-tighten or replace.	If an engine is operated with an oil leakag unnoticed, a serious trouble may develop.
Check for external fuel leakage. If any, re-tighten or replace.	Not only wasteful but also dangerous.
Check screw tightness. If any loose one is found, re-tighten.	Loose screws and nuts will result in vibration and accidents.
Check oil level in crankcase and add up as necessary.	If an engine is operated without sufficient oil, it will fail.
Check oil level in reduction case and add up as necessary.	If an engine is operated without sufficient oil, it will fail.

13-2 EVERY 50 HOURS (10 DAYS) CHECKS AND MAINTENANCE

Checks and maintenance	Reasons for requiring them
Change crankcase oil	Contaminated oil accelerates wear.
Check electrolyte level in battery. Add up as necessary	Battery may get completely deteriorated.
Clean spark plug.	Engine output is reduced.

13-3 EVERY 100–200 HOURS (MONTHLY) CHECKS AND MAINTENANCE

Checks and maintenance	Reasons for requiring them
Clean carburetor and air cleaner.	The engine will get out of order
Clean fuel strainer and fuel tank.	The engine will get out of order.
Clean spark plug gap and breaker points	Engine output is reduced.
Change reduction case oil.	If an engine is operated without sufficient oil, it will fail.

13-4 EVERY 300–600 HOURS CHECKS AND MAINTENANCE

Checks and maintenance	Reasons for requiring them
Dismantle cylinder head and remove carbon.	The engine will be out of order
Check intake and exhaust valves, lap valve face, and adjust tappet clearance.	Engine output will be lost and engine will get out of order.
Dismantle cooling blower and clean AC generator.	Battery charging becomes insufficient.
Disassemble and clean carburetor.	Engine will be out of order.

13-5 EVERY 700–1000 HOURS CHECKS AND MAINTENANCE

Checks and maintenance	Reasons for requiring them
Perform overhauls, clean, correct or replace parts.	Engine output will be lost and engine will get out of order.
Replace piston rings	Engine output will be lost and engine will get out of order.

13-6 PREPARATION FOR LONG ABEYANCE

- 1) Perform the above 13-1, 13-2 and 13-3 maintenance jobs.
- 2) Drain fuel from the fuel tank.
- 3) To prevent rust in the cylinder bore, apply oil through the spark plug holes and turn the crankshaft several revolutions by hand.
If the engine is operated with a 1:1 gasoline–oil mixture as the fuel for one minute (white smoke comes out), rust-prevention is perfect.
- 4) Bring the spark timing mark and the dust plate hole in alignment.
- 5) Clean the engine outside with oiled cloth.
- 6) Store the engine in dry place.
- 7) Charge the battery once a month.
- 8) Disconnect the battery negative lead and keep it disconnected during storage.



Robin Engine





Robin Engine





Robin Engine



Robin America, Inc.

940 Lively Blvd., Wood Dale, IL 60191 • Tel: (708) 350-8200 • Fax: (708) 350-8212