

P66 Series Electronic Fan Speed Controls

Product Bulletin

Code No. LIT-125465
Issued September 30, 2009
Supersedes March 23, 2006

The P66 Series Electronic Fan Speed Controls are refrigerant pressure actuated, electronic motor-speed controllers. The P66 controls are designed for use with single-phase permanent split-capacitor motors that are approved by the motor manufacturer for speed control applications.

The P66 controls provide condenser pressure control by directly sensing condenser refrigerant pressure and automatically adjusting the condenser fan motor speed according to the sensed pressure.

The P66 provides an alternative to fan cycling control in many small and medium size refrigeration and Heating, Ventilating, and Air Conditioning (HVAC) applications.

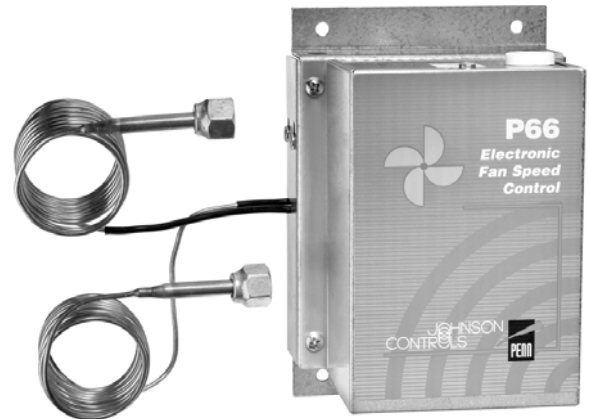

Figure 1: P66 Dual Sensor Fan Speed Control

Table 1: Features and Benefits

Features	Benefits
Exclusive Johnson Controls/PENN® Pressure Transducer	Responds quickly to condenser pressure changes and condenser air delivery requirements
Soft Start Capability	Provides a smooth fan startup, which reduces motor-starting noise and abrupt changes in motor speed
208-240/277/480 VAC, 60 Hz Motor Control	Suitable for a wide range of condenser fan motor applications
One or Two Pressure Transducers	Applicable to single- and multi-circuit condensers. The dual-sensor P66 control models select the higher pressure input to control the fan speeds.
Two Effective Throttling Ranges (ETRs)	Provide either a 30 or 60 psi (207 or 414 kPa) ETR
NEMA 1 or NEMA 3R (Rainproof) Enclosure	Allows indoor and panel mounting or outdoor mounting applications
Built-in Voltage Surge Protection, Radio Frequency Interference (RFI) Suppression, and Ground Terminal Screw	Achieves trouble-free operation

Application

IMPORTANT: Use this P66 Series Electronic Fan Speed Control only as an operating control. Where failure or malfunction of the P66 control could lead to personal injury or property damage to the controlled equipment or other property, additional precautions must be designed into the control system. Incorporate and maintain other devices, such as supervisory or alarm systems or safety or limit controls, intended to warn of or protect against failure or malfunction of the P66 control.

The P66 Series Electronic Fan Speed Controls are pressure-actuated electronic motor-speed controllers designed primarily to control condenser fan motors on Heating, Ventilating, Air Conditioning, and Refrigeration (HVAC/R) applications (Figure 2). These controls regulate the supply voltage to the fan motor in response to the sensed refrigerant pressure, providing direct response to changes in condenser pressure, regardless of the variations in air delivery curves.

P66 controls are available with one or two pressure sensor inputs. In dual sensor models, the control selects the input with the greatest demand.

P66 control models are also available with NEMA 3R (Rainproof) enclosures for outdoor applications (Figure 1). These models come with a plastic enclosure, appropriate gaskets, and low voltage wire leads for 24 VAC power. In addition, the critical high voltage components are encapsulated in a potting compound.

Note: NEMA 1 models **cannot** be retrofitted in the field to obtain the NEMA 3R (Rainproof) rating.

A P66 and speed control motor can replace On/Off fan cycling controls, multiple speed motors, condenser flood-back systems, temperature fan-speed controls, and modulating louver systems.

Typical applications include:

- computer room air conditioning
- commercial air conditioning
- commercial refrigeration



CAUTION: Risk of Property Damage

Use only single-phase Permanent Split-Capacitor (PSC) motors approved by the manufacturer for speed control applications with the P66 control. Failure to use a single-phase PSC motor may damage the motor and other property.

The P66 Series controls must be applied only to single-phase motors intended for use with a solid-state motor speed control. An applicable motor must be a single-phase, permanent split-capacitor motor and must be:

- ball-bearing construction only (Sleeve-bearing motors are not acceptable for use with P66 controls.)
- designed to handle non-sinusoidal waveforms generated by solid-state motor speed controls
- designed to dissipate the motor heat generated at reduced speed operation

Operation

Condensing unit installation, operation, and maintenance determine the overall capability to maintain a satisfactory pressure by means of fan speed control. Within the operating range, the P66 control provides air delivery in direct proportion to heat rejection requirements. This allows the refrigeration system to perform efficiently, even in very low ambient temperatures.

The P66 pressure transducer provides direct response to changes in condenser pressure, regardless of the variations in fan delivery curves. The dual input models select the pressure input from the transducer sensing the highest pressure.

See Figure 2 for a typical operational sequence for a P66 control.

Repair and Replacement

Do not make field repairs. For a replacement control, contact the Original Equipment Manufacturer or your local Johnson Controls/PENN distributor.

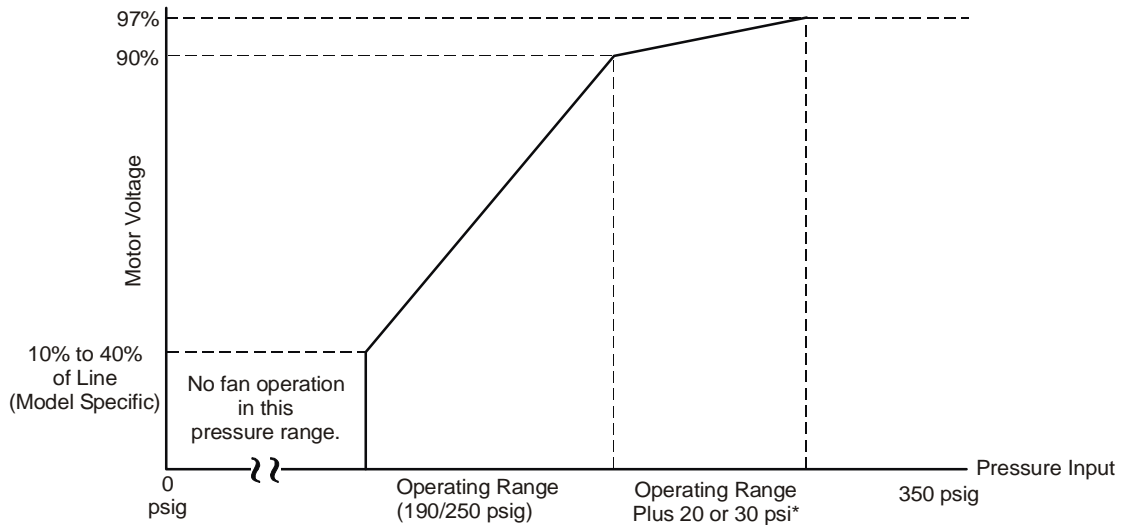

*20 psi for 30 psi Effective Throttling Range (ETR)
 30 psi for 60 psi Effective Throttling Range (ETR)

FIG:P66_OP_CHART

Figure 2: Operation Chart for the P66 Fan Speed Control

Table 2: P66 Control Operation

Pressure Input	Motor Voltage
Pressure is between 0 psig and the low end of the operating range.	0 to 5 volts
Pressure is at the low end of the operating range.	Start voltage: 10% to 40% of line - Model Specific (See Table 3.)
Pressure is in the operating range.	Motor voltage varies directly with system pressure from start voltage to 90% of line voltage.
Pressure is above the operating range.	A further pressure increase of 20 to 30 psi increases motor voltage to 97% of the applied voltage.

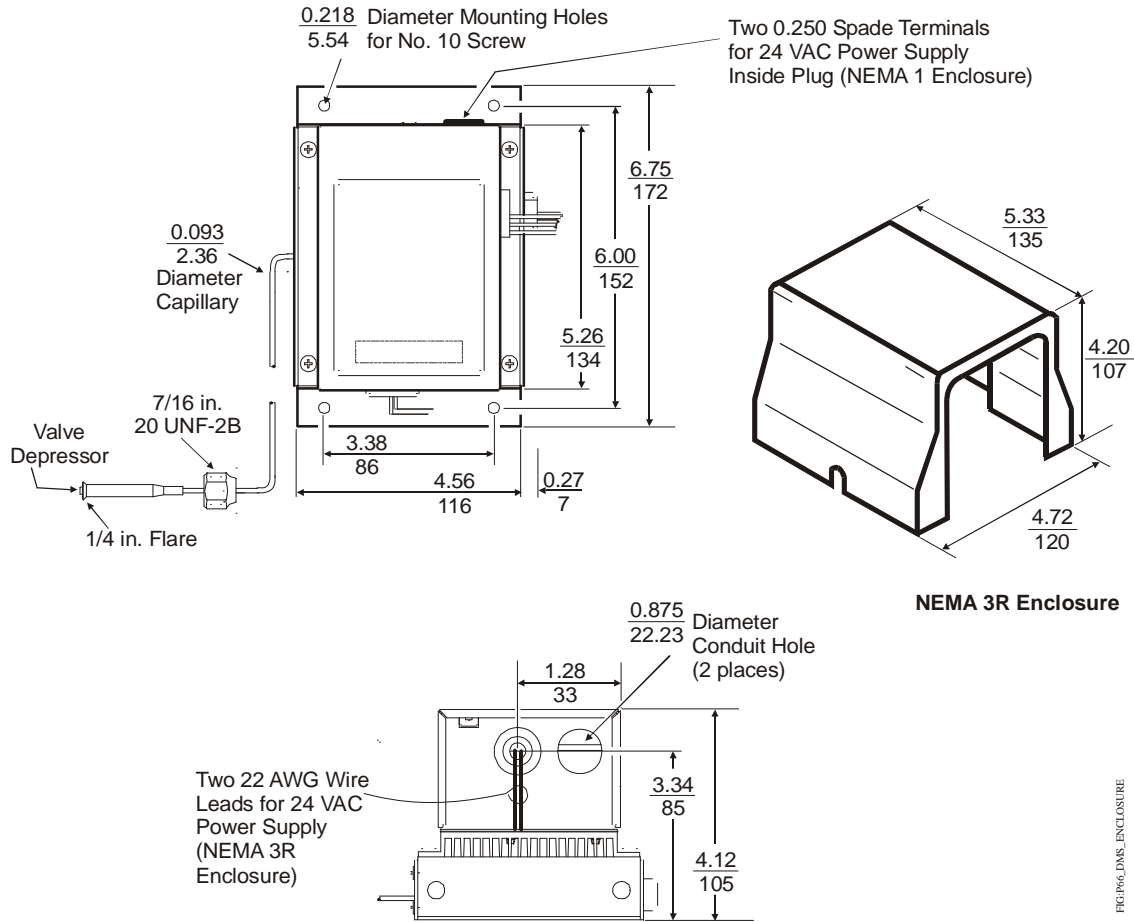

Figure 3: P66 Control and NEMA 3R Enclosure Dimensions, in./mm

Ordering Information

Table 3: P66 Series Control Model Information¹

Product Code Number	Operating Pressure Range (psig)	Start Voltage (% of Supply Voltage)	Capillary Length (in.)
Single Input Sensor Models			
P66AAB-1C	190-250	10	60
P66AAB-4C	135-165	10	60
P66AAB-6C	170-230	16	60
P66AAB-9C	170-230	40	60
P66AAB-10C	190-250	16	120
P66AAB-11C	140-200	16	60
P66AAB-13C	60-90	16	60
P66AAB-14C	220-280	40	120
P66AAB-15C	190-250	40	60
P66AAB-19C	115-145	40	60
P66AAB-25C	180-240	10	120
P66AAB-26C	220-280	40	60
P66AAB-34C	320-410	40	60
P66AAD-1C*	160-220	25	60
Dual Input Sensor Models			
P66BAB-1C	190-250	10	60
P66BAB-3C	170-230	16	60
P66BAB-4C	190-250	16	120
P66BAB-5C	190-250	40	60
P66BAB-9C	320-410	40	60
P66BAD-1C*	160-220	25	60
NEMA 3R Models			
P66ABB-21C	220-280	16	120
P66ABB-24C	190-250	16	60
P66ABB-27C	170-230	40	60

1. All models are rated for 208-240/277/480 volt; 60 Hz except those with Product Code Numbers followed by an asterisk, indicating 50 Hz Models.

Table 4: Fan Speed Control Replacement Guide (Part 1 of 2)¹

Original Control Model Number	Replacement P66 Product Code Number
P15AJ-39	P66AAB-4C
P15AK-11	P66AAB-6C
P15AK-12	P66ABB-21C
P15AK-13	P66AAB-6C
P15AK-14	P66AAB-1C
P15DJ-5	P66AAB-6C
P15JJ-2 (Liebert® models)	P66AAB-1C
P15JJ-2 (Non Liebert models)	P66AAB-9C

Table 4: Fan Speed Control Replacement Guide (Part 2 of 2)¹

Original Control Model Number	Replacement P66 Product Code Number
P15JJ-7	P66ABB-21C
P15JJ-8	P66AAB-1C
P65AAB-1	P66AAB-1C
P65AAB-2	P66AAB-1C
P65AAB-4	P66AAB-4C
P65AAB-6	P66AAB-6C
P65AAB-9	P66AAB-9C
P65AAB-10	P66AAB-10C
P65BAB-1	P66BAB-1C
P65BAB-2	P66BAB-1C
P65BAB-5	P66BAB-5C
P65AAB-2	P66AAB-1C
P66AAB-18	P66AAB-25C
P66AAB-21	P66ABB-21C
P66BAB-2	P66BAB-1C
P66BAB-4	P66BAB-1C

1. When two P15s are used in parallel with one motor, replace both P15s with one P66BAB. Select the P66BAB with an operating range similar to that of the P15s being replaced. When replacing a P15 or P65 with a P66, 24 VAC must be provided. It is recommended that the P66 be used only with low heat rise ball bearing motors that are approved by the motor manufacturer for fan speed control operation. Start voltage for P15 motors = 40%.

Technical Specifications

P66 Series Electronic Fan Speed Controls (Part 1 of 2)

Pressure Ratings: Low Pressure Models	Control Range: 80 to 200 psig (552 to 1,379 kPa) Effective Throttling Range: 30 psig (207 kPa) Maximum Working Pressure: 200 psig (1,379 kPa) Maximum Overpressure: 250 psig (1,724 kPa)
Pressure Ratings: Medium Pressure Models	Control Range: 140 to 350 psig (965 to 2,413 kPa) Effective Throttling Range: 60 psig (414 kPa) Maximum Working Pressure: 350 psig (2,413 kPa) Maximum Overpressure: 400 psig (2,758 kPa)
Pressure Ratings: High Pressure Models	Control Range: 300 to 500 psig (2,068 to 3,447 kPa) Effective Throttling Range: 90 psig (621 kPa) Maximum Working Pressure: 500 psig (3,447 kPa) Maximum Overpressure: 610 psig (4,206 kPa)
Control Voltage	24 VAC, Class 2, 1 A
Line Voltage Range	208 to 480 VAC
Start Voltage	10% to 40% of line (Original Equipment Manufacturer [OEM] specified - model specific)
Electrical Ratings: 208 VAC	Full Load Amperes: 8.0 Locked Rotor Amperes: 16.5 Ambient Temperature Maximum: 130°F/54°C
Electrical Ratings: 240 VAC	Full Load Amperes: 8.0 Locked Rotor Amperes: 16.5 Ambient Temperature Maximum: 130°F/54°C

P66 Series Electronic Fan Speed Controls (Part 2 of 2)

Electrical Ratings: 277 VAC	Full Load Amperes: 6.9 Locked Rotor Amperes: 14.3 Ambient Temperature Maximum: 130°F/54°C
Electrical Ratings: 480 VAC	Full Load Amperes: 4.0 Locked Rotor Amperes: 10.5 Ambient Temperature Maximum: 150°F/66°C
Ambient Temperature Minimum	-40°F/-40°C (at all voltages)
Ambient Storage Temperature	-40°F/-40°C to 185°F/85°C
Construction	Control Case: Galvanized steel case and cover Base and Sensors: Galvanized steel Plastic Enclosure: UV stabilized polycarbonate with closed cell foam gasket (NEMA 3R models only)
Enclosure	NEMA 1 or NEMA 3R (Rainproof)
Wiring Connections	Low Voltage: 1/4 in. quick connects (NEMA 1); Two 6 in. 22 AWG Wire Leads (NEMA 3R) Line Voltage: 10-32 Screw Terminals
Pressure Connections	60 in./1.5 m or 120 in./3.0 m copper capillary with 1/4 in./6 mm flare nut and Schrader® valve depressor
Mounting	Vertical only; two holes for No. 10 screws at the top and bottom
Compliance	UL Recognized (U.S.): File SA516, Guide SDFY2 UL Recognized (Canada): File SA516, Guide SDFY8

The performance specifications are nominal and conform to acceptable industry standards. For application at conditions beyond these specifications, contact Johnson Controls Application Engineering at 1-800-275-5676. Johnson Controls, Inc. shall not be liable for damages resulting from the misapplication or misuse of its products.



Building Efficiency

507 E. Michigan Street, Milwaukee, WI 53202

Metasys® and Johnson Controls® are registered trademarks of Johnson Controls, Inc. All other marks herein are the marks of their respective owners. © 2009 Johnson Controls, Inc.