



PA-500, PA-2000 Series, and PA-4000 Series Firewalls Security Policy

Version: C

Palo Alto Networks

Revision Date: 5/31/2011

www.paloaltonetworks.com © 2011 Palo Alto Networks. May be reproduced only in its original entirety (without revision). Palo Alto Networks, PAN-OS, and Panorama are trademarks of Palo Alto Networks, Inc. All other trademarks are the property of their respective owners.

P/N 880-000018-00C

CHANGE RECORD

Table 1 - Change Record

<i>Revision</i>	<i>Date</i>	<i>Author</i>	<i>Description of Change</i>
A	8/23/2010	N. Campagna	Initial authoring
B	1/24/2011	N. Campagna	Added detail to the identity and authentication of IPSec endpoints.
C	5/31/2011	N. Campagna	Added FW Version 3.1.7-h1

Contents

1	Module Overview	6
2	Security Level.....	13
3	Modes of Operation	14
3.1	<i>FIPS Approved Mode of Operation</i>	14
3.2	<i>Approved and Allowed Algorithms</i>	15
3.3	<i>Non-Approved, Non-Allowed Algorithms</i>	15
4	Ports and Interfaces	17
5	Identification and Authentication Policy	19
5.1	<i>Assumption of Roles</i>	19
6	Access Control Policy.....	21
6.1	<i>Roles and Services</i>	21
6.2	<i>Unauthenticated Services</i>	21
6.3	<i>Definition of Critical Security Parameters (CSPs)</i>	22
5.3a	<i>Definition of Public Keys</i>	23
6.4	<i>Definition of CSPs Modes of Access</i>	25
7	Operational Environment.....	26
8	Security Rules	26
9	Physical Security Policy.....	28
9.1	<i>Physical Security Mechanisms</i>	28
9.2	<i>Operator Required Actions</i>	32
10	Mitigation of Other Attacks Policy	33
11	References.....	33
12	Definitions and Acronyms	33
13	Appendix A – PA-500 – FIPS Accessories/Tamper Seal Installation	35
14	Appendix B - PA-2000 Series – FIPS Accessories/Tamper Seal Installation.....	40
15	Appendix C - PA-4000 Series – FIPS Accessories/Tamper Seal Installation.....	44

Tables

Table 1 - Change Record	2
Table 2 - Validated Version Information	11
Table 3 - Module Security Level Specification.....	13
Table 4 - FIPS Approved Algorithms Used in Current Module	15
Table 5 – FIPS Allowed Algorithms Used in Current Module	15
Table 6 - Non-Approved, Non-Allowed Algorithms Used in Current Module.....	15
Table 7 – PA-500 FIPS 140-2 Ports and Interfaces	17
Table 8 – PA-2000 Series FIPS 140-2 Ports and Interfaces.....	17
Table 9 – PA-4000 Series FIPS 140-2 Ports and Interfaces.....	17
Table 10 - Roles and Required Identification and Authentication	19
Table 11 – Strengths of Authentication Mechanisms	20
Table 12 – Authenticated Service Descriptions.....	21
Table 13 – Authenticated Services	21
Table 14 - Unauthenticated Services	21
Table 15 - Private Keys and CSPs.....	22
Table 16 - Public Keys.....	23
Table 17 - CSP Access Rights within Roles & Services	25
Table 18 - Inspection/Testing of Physical Security Mechanisms.....	32

Figures

Figure 1 - PA-500 Front Image	8
Figure 2 - PA-500 Back Image.....	8
Figure 3 - PA-500 with Front Opacity Shield	8
Figure 4 - PA-500 with Side Opacity Shield	8
Figure 5 - PA-2020 / PA-2050 Front Images	9
Figure 6 - PA-2020 / PA-2050 Back Image.....	9
Figure 7 - PA-2020 / PA-2050 Front Opacity Shield	9
Figure 8 - PA-2020 / PA-2050 with Side Opacity Shield	9
Figure 9 - PA-4020 / PA-4050 Front Image	10
Figure 10 - PA-4060 Front Image	10
Figure 11 - PA-4020 / PA-4050 / PA-4060 Back Image.....	10
Figure 12 - Logical Block Diagram	12

Figure 13 - PA-500 Front Tamper Seal Placement (1)	28
Figure 14 - PA-500 Left Side Tamper Seal Placement (2)	28
Figure 15 - PA-500 Right Side Tamper Seal Placement (2)	29
Figure 16 - PA-500 Rear Tamper Seal Placement (4)	29
Figure 17 - PA-2000 Series Front Tamper Seal Placement (1)	29
Figure 18 - PA-2000 Series Left Side Tamper Seal Placement (3)	29
Figure 19 - PA-2000 Series Right Side Tamper Seal Placement (3)	30
Figure 20 - PA-2000 Series Rear Tamper Seal Placement (2)	30
Figure 21 - PA-4000 Series Rear Tamper Seal Placement – From Top (4)	30
Figure 22 - PA-4000 Series Rear Side Tamper Seal Placement – From Underside (4)	31
Figure 23 - PA-4000 Series Right Side Tamper Seal Placement (1)	31
Figure 24 - PA-4000 Series Left Side Tamper Seal Placement (1)	31

1 Module Overview

The Palo Alto Networks PA-500, PA-2000 Series, and PA-4000 Series firewalls (hereafter referred to as the modules) are multi-chip standalone modules that provide network security by enabling enterprises to see and control applications, users, and content – not just ports, IP addresses, and packets – using three unique identification technologies: App-ID, User-ID, and Content-ID. These identification technologies, found in Palo Alto Networks' enterprise firewalls, enable enterprises to create business-relevant security policies – safely enabling organizations to adopt new applications, instead of the traditional “all-or-nothing” approach offered by traditional port-blocking firewalls used in many security infrastructures.

Features and Benefits

- **Application visibility and control:** Accurate identification of the applications traversing the network enables policy-based control over application usage at the firewall, the strategic center of the security infrastructure.
- **Visualization tools:** Graphical visibility tools, customizable reporting and logging enables administrators to make a more informed decision on how to treat the applications traversing the network.
- **Application browser:** Helps administrators quickly research what the application is, its' behavioral characteristics and underlying technology resulting in a more informed decision making process on how to treat the application.
- **User-based visibility and control:** Seamless integration with enterprise directory services (Active Directory, LDAP, eDirectory) facilitates application visibility and policy creation based on user and group information, not just IP address. In Citrix and terminal services environments, the identity of users sitting behind Citrix or terminal services can be used to enable policy-based visibility and control over applications, users and content. An XML API enables integration with other, 3rd party user repositories.
- **Real-time threat prevention:** Detects and blocks application vulnerabilities, viruses, spyware, and worms; controls web activity; all in real-time, dramatically improving performance and accuracy.
- **File and data filtering:** Taking full advantage of the in-depth application inspection being performed by App-ID, administrators can implement several different types of policies that reduce the risk associated with unauthorized file and data transfer.
- **Legacy firewall support:** Support for traditional inbound and outbound port-based firewall rules mixed with application-based rules smoothes the transition to a Palo Alto Networks next generation firewall.

- **Networking architecture:** Support for dynamic routing (OSPF, RIP, BGP), virtual wire mode and layer 2/layer 3 modes facilitates deployment in nearly any networking environment.
- **Policy-based Forwarding:** Forward traffic based on policy defined by application, source zone/interface, source/destination address, source user/group, and service.
- **Virtual Systems:** Create multiple virtual “firewalls” within a single device as a means of supporting specific departments or customers. Each virtual system can include dedicated administrative accounts, interfaces, networking configuration, security zones, and policies for the associated network traffic.
- **VPN connectivity:** Secure site-to-site connectivity is enabled through standards-based IPsec VPN support while remote user access is delivered via SSL VPN connectivity.
- **Quality of Service (QoS):** Deploy traffic shaping policies (guaranteed, maximum and priority) to enable positive policy controls over bandwidth intensive, non-work related applications such as streaming media while preserving the performance of business applications.
- **Real-time bandwidth monitor:** View real-time bandwidth and session consumption for applications and users within a selected QoS class.
- **Purpose-built platform:** combines single pass software with parallel processing hardware to deliver the multi-Gbps performance necessary to protect today’s high speed networks.

Note: Modules are shown in figures with no opacity shields included to demonstrate module interfaces and other physical characteristics. Pictures are included of each chassis with the opacity shields in place.

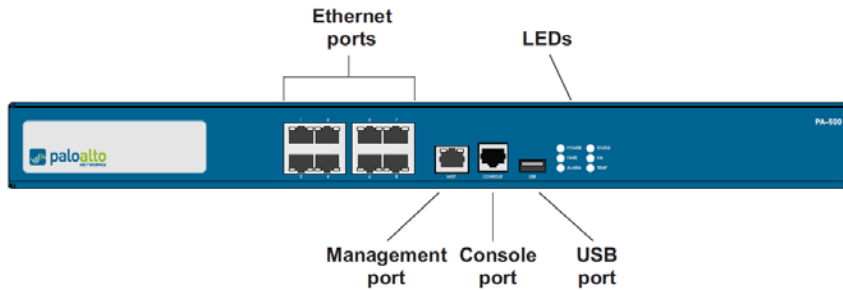

Figure 1 - PA-500 Front Image

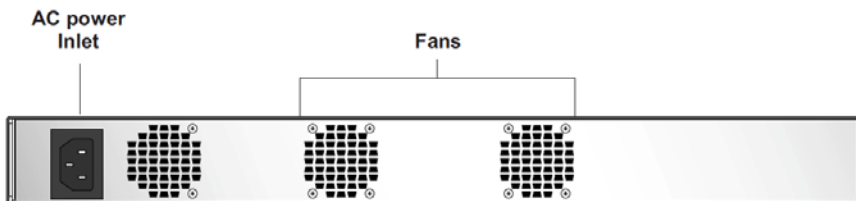

Figure 2 - PA-500 Back Image

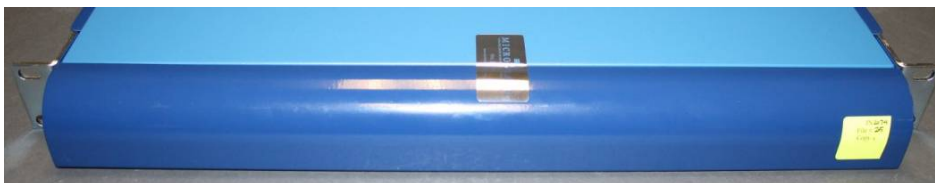

Figure 3 - PA-500 with Front Opacity Shield



Figure 4 - PA-500 with Side Opacity Shield

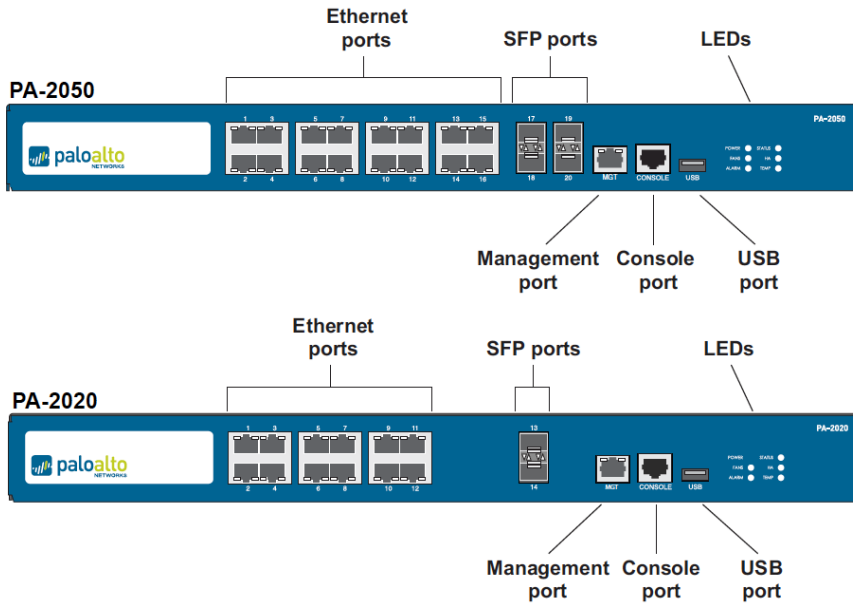

Figure 5 - PA-2020 / PA-2050 Front Images

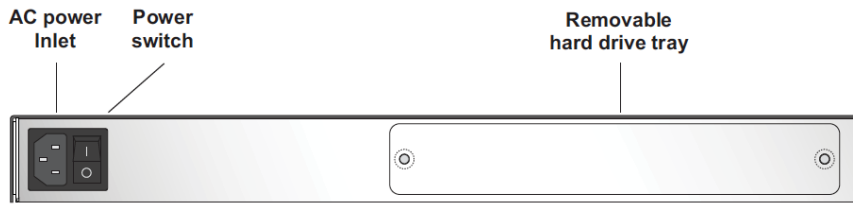

Figure 6 - PA-2020 / PA-2050 Back Image

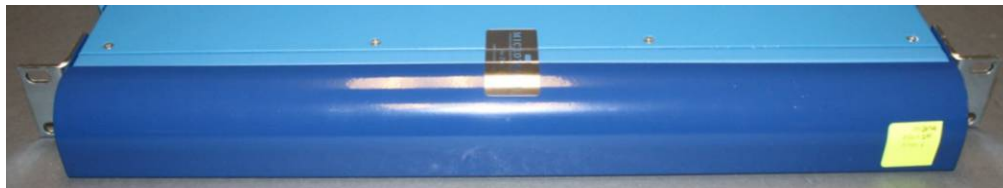

Figure 7 - PA-2020 / PA-2050 Front Opacity Shield



Figure 8 - PA-2020 / PA-2050 with Side Opacity Shield

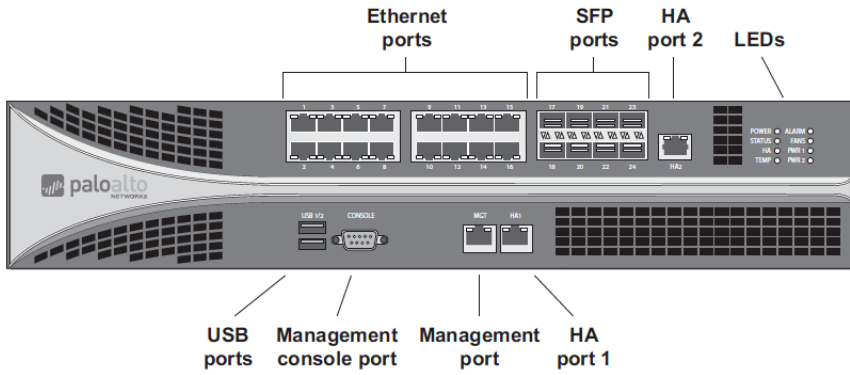

Figure 9 - PA-4020 / PA-4050 Front Image

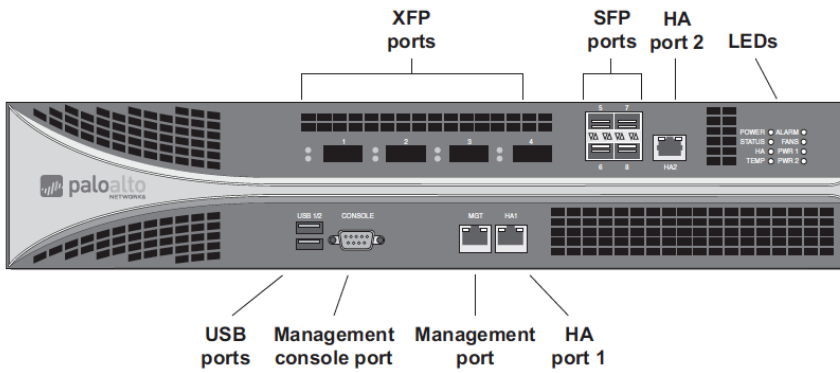

Figure 10 - PA-4060 Front Image

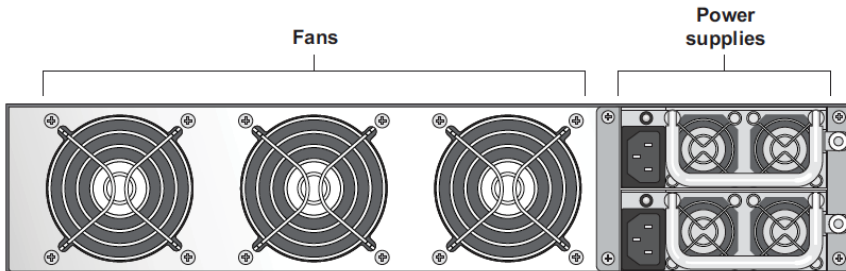

Figure 11 - PA-4020 / PA-4050 / PA-4060 Back Image



Figure 12 - PA-4020 / PA-4050 / PA-4060 Left Side with Opacity Shield

The configurations for this validation are:

Table 2 - Validated Version Information

Module	Part Number	Hardware Version	FIPS Kit Part Number	FIPS Kit Hardware Version	Firmware Version
PA-500	910-000006-00D	Rev. D	920-000005-001	Rev. 1	3.1.2 or 3.1.7-h1
PA-2020	910-000004-00K	Rev. K	920-000004-001	Rev. 1	3.1.2 or 3.1.7-h1
PA-2050	910-000003-00K	Rev. K	920-000004-001	Rev. 1	3.1.2 or 3.1.7-h1
PA-4020	910-000002-00Q	Rev. Q	920-000003-001	Rev. 1	3.1.2 or 3.1.7-h1
PA-4050	910-000001-00P	Rev. P	920-000003-001	Rev. 1	3.1.2 or 3.1.7-h1
PA-4060	910-000005-00G	Rev. G	920-000003-001	Rev. 1	3.1.2 or 3.1.7-h1

Figure 12 depicts the logical block diagram for the modules. The cryptographic boundary includes all of the logical components of the modules and the boundary is the physical enclosure of the firewall.

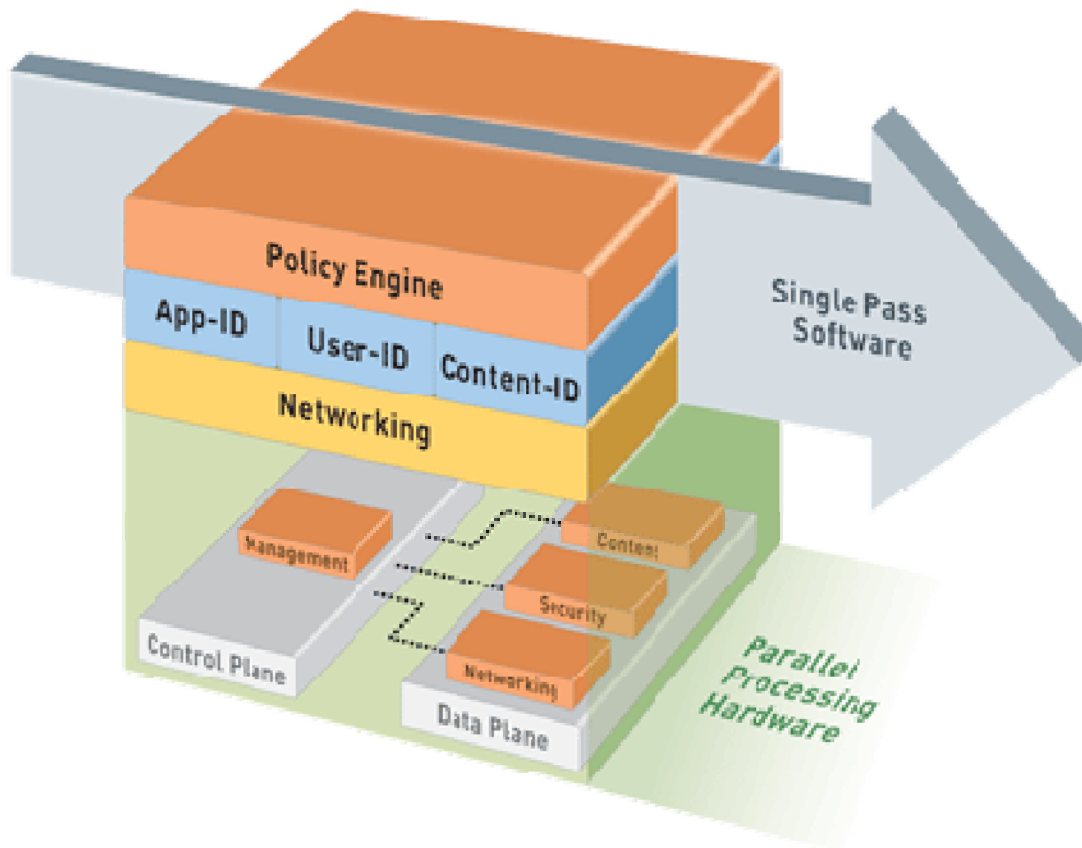

Figure 12 - Logical Block Diagram

2 Security Level

The cryptographic modules meet the overall requirements applicable to Level 2 security of FIPS 140-2.

Table 3 - Module Security Level Specification

Security Requirements Section	Level
Cryptographic Module Specification	3
Module Ports and Interfaces	2
Roles, Services and Authentication	3
Finite State Model	2
Physical Security	2
Operational Environment	N/A
Cryptographic Key Management	2
EMI/EMC	2
Self-Tests	2
Design Assurance	3
Mitigation of Other Attacks	N/A

3 Modes of Operation

3.1 *FIPS Approved Mode of Operation*

The modules support both a FIPS mode and a non-FIPS mode. The following procedure will put the modules into the FIPS mode of operation:

- During initial boot up, break the boot sequence via the console port connection (by pressing the m button when instructed to do so) to access the main menu.
- Select “Continue.”
- Select the “Set FIPS Mode” option to enter FIPS mode.
- Select “Enable FIPS Mode”.
- When prompted, select “Reboot” and the module will re-initialize and continue into FIPS mode.
- The module will reboot.
- In FIPS mode, the console port is available only as a status output port.

The module will automatically indicate the FIPS Approved mode of operation in the following manner:

- Status output interface will indicate “***** FIPS MODE ENABLED *****” via the CLI session.
- Status output interface will indicate “FIPS Mode Enabled Successfully” via the console port.
- The module will display “FIPS mode” at all times in the status bar at the bottom of the web interface.

Should one or more power-up self-tests fail, the FIPS Approved mode of operation will not be achieved. Feedback will consist of:

- The module will reboot and enter a state in which the reason for the reboot can be determined.
- To determine which self-test caused the system to reboot into the error state, connect the console cable and follow the on-screen instructions to view the self-test output.
- Install FIPS kit opacity shields and tamper evidence seals according to Section 9.
- The tamper evidence seals and opacity shields shall be installed for the module to operate in a FIPS Approved mode of operation.

3.2 *Approved and Allowed Algorithms*

The cryptographic modules support the following FIPS Approved algorithms.

Table 4 - FIPS Approved Algorithms Used in Current Module

FIPS Approved Algorithm	CAVP Cert. #
AES	1378
TDES	950
RSA	675
DSA	451
HMAC-SHA-1, HMAC-SHA-256	810
SHA-1, SHA-2	1259
ANSI x9.31 RNG	760

The cryptographic modules support the following non-FIPS Approved algorithms that are allowed for use in FIPS mode.

Table 5 – FIPS Allowed Algorithms Used in Current Module

FIPS Allowed Algorithm
Diffie-Hellman (key establishment methodology provides 112 bits of encryption strength)
RSA (key wrapping, key establishment methodology provides 112 bits of encryption strength)
NDRNG (used to seed ANSI x9.31 RNG)
MD5 (within TLS)

3.3 *Non-Approved, Non-Allowed Algorithms*

The cryptographic modules support the following non-Approved algorithms. No security claim is made in the current modules for any of the following non-Approved algorithms.

Table 6 - Non-Approved, Non-Allowed Algorithms Used in Current Module

Non-FIPS Allowed Algorithm in Non-FIPS Mode
MD5 – used for hashing of non-security relevant data; in CHAP authentication with RADIUS servers; in authentication for OSPF, RIP, and BGP dynamic routing protocols; for password hashing on Data Leakage Protection and Administrator passwords; and to integrity check URL filtering database downloads (note this is in addition to HMAC-SHA-1 authentication/integrity check). MD5 is also used to authenticate communications with the security module. MD5 is also used to hash administrator passwords.

Non-FIPS Allowed Algorithm in Non-FIPS Mode

RC4 – used to encrypt SSL communications with the security module.

Camellia - used to encrypt SSL communications with the security module.

RC2 - used to encrypt SSL communications with the security module.

SEED - used to encrypt SSL communications with the security module.

DES - used to encrypt SSL communications with the security module.

4 Ports and Interfaces

The modules are multi-chip standalone modules with ports and interfaces as shown below.

Table 7 – PA-500 FIPS 140-2 Ports and Interfaces

Interface	PA-500	FIPS 140-2 Designation	Name and Description
RJ45	1	Data input, control input, data output, status output	Console port
RJ45	1	Data input, control input, data output, status output	Out of band management
RJ45	8	Data input, control input, data output, status output	10/100/1000 Ethernet interface
100-240 Vcc	1	Power input	Power interface
LEDs	6	Status output	Status indicators
USB	1	Disabled except for power	Used in manufacturing

Table 8 – PA-2000 Series FIPS 140-2 Ports and Interfaces

Interface	PA-2050	PA-2020	FIPS 140-2 Designation	Name and Description
RJ45	1	1	Data input, control input, data output, status output	Console port
RJ45	1	1	Data input, control input, data output, status output	Out of band management
SFP	4	2	Data input, control input, data output, status output	Ethernet optical gigabit interface
RJ45	16	12	Data input, control input, data output, status output	10/100/1000 Ethernet interface
100-240 Vcc	1	1	Power input	Power interface
LEDs	6	6	Status output	Status indicators
USB	1	1	Disabled except for power	Used in manufacturing

Table 9 – PA-4000 Series FIPS 140-2 Ports and Interfaces

Interface	PA-4060	PA-4050	PA-4020	FIPS 140-2 Designation	Name and Description
DB9	1	1	1	Data input, control input, data output, status output	Console port
RJ45	1	1	1	Data input, control input,	Out of band

Interface	PA-4060	PA-4050	PA-4020	FIPS 140-2 Designation	Name and Description
				data output, status output	management
XFP	4	0	0	Data input, control input, data output, status output	Ethernet optical 10-gigabit interface
SFP	4	8	8	Data input, control input, data output, status output	Ethernet optical gigabit interfaces
RJ45	2	2	2	Data input, control input, data output, status output	10/100/1000 HA Ethernet interface
RJ45	0	16	16	Data input, control input, data output, status output	10/100/1000 Ethernet Interfaces
100-240 Vcc	2	2	2	Power input	Power interface
LEDs	8	8	8	Status output	Status indicators
USB	2	2	2	Disabled except for power	Used in manufacturing

5 Identification and Authentication Policy

5.1 Assumption of Roles

The modules support four distinct operator roles, User and Cryptographic Officer (CO), Remote Access VPN, and Site-to-site VPN. The cryptographic modules enforce the separation of roles using unique authentication credentials associated with operator accounts. The modules support concurrent operators.

The modules do not provide a maintenance role or bypass capability.

Table 10 - Roles and Required Identification and Authentication

Role	Description	Authentication Type	Authentication Data
CO	This role has access to all services offered by the modules. Within the PAN-OS software, this role maps to the “Superuser” administrator role.	Identity-based operator authentication	Username and password (optional certificate based authentication can be added in addition to username and password)
User	This role has limited access to services offered by the modules. This role does not have access to modify or view the passwords associated with other administrator accounts, it may not view or alter CSPs of any type stored on the module. Within the PAN-OS software, this role maps to the “Superuser (read-only)” administrator role (also referred to as “Superreader”).	Identity-based operator authentication	Username and password (optional certificate based authentication can be added in addition to username and password)
Remote Access VPN (RA VPN)	Remote user accessing the network via VPN.	Identity-based operator authentication	Username and password (optional certificate based authentication can be added in addition to username and password)
Site-to-site VPN (S-S VPN)	Remote VPN device establishing a VPN session to facilitate access to the network.	Identity-based operator authentication	IKE/IPSec Pre-shared keys - Identification with the IP Address and authentication with the Pre-Shared Key .

Table 11 – Strengths of Authentication Mechanisms

Authentication Mechanism	Strength of Mechanism
Username and Password	Minimum length is 6 alphanumeric characters (62 possible characters). The probability that a random attempt will succeed or a false acceptance will occur is $1/(62^6)$ which is less than $1/1,000,000$. The probability of successfully authenticating to the module within one minute is $10/(62^6)$, which is less than $1/100,000$. The firewall's configuration supports at most ten attempts to authenticate in a one-minute period.
Certificate based authentication	The security modules support certificate-based authentication using 2048 bit RSA keys. Such keys possess an equivalent strength of 112 bits. The probability that a random attempt will succeed is $1/(2^{112})$ which is less than $1/1,000,000$. The probability of successfully authenticating to the module within a one minute period is $3,600,000/(2^{112})$, which is less than $1/100,000$. The firewall supports at most 60,000 new sessions per second to authenticate in a one-minute period.
IKE/IPSec pre-shared keys	The 160 bit key length supports 2^{160} different combinations. The probability of successfully authenticating to the module is $1/(2^{160})$, which is less than $1/1,000,000$. The number of authentication attempts is limited by the number of new connections per second supported (60,000) on the fastest platform of the Palo Alto Networks firewalls. The probability of successfully authenticating to the module within a one minute period is $3,600,000/(2^{160})$, which is less than $1/100,000$.

6 Access Control Policy

6.1 Roles and Services

Table 12 – Authenticated Service Descriptions

Service	Description
Security Configuration Management	Configuring and managing cryptographic parameters and setting/modifying security policy, including creating User accounts and additional CO accounts.
Other Configuration	Networking parameter configuration, logging configuration, and other non-security relevant configuration.
View Other Configuration	Read-only of non-security relevant configuration (see above).
Show Status	View status via the web interface or command line interface.
VPN	Provide network access for remote users or site-to-site connections.
Firmware update	Provides a method to update the firmware on the firewall.

Table 13 – Authenticated Services

Service	Crypto Officer	User	RA VPN	S-S VPN
Security Configuration Management	Y	N	N	N
Other Configuration	Y	N	N	N
View Other Configuration	Y	Y	N	N
Show Status	Y	Y	Y	Y
VPN	N	N	Y	Y
Firmware update	Y	N	N	N

6.2 Unauthenticated Services

The cryptographic module supports the following unauthenticated services:

Table 14 - Unauthenticated Services

Service	Description
Zeroize	The device will overwrite all CSPs.
Self-Tests	Run power up self-tests on demand by power cycling the module.
Show Status (LEDs)	View status of the module via the LEDs.

Zeroize

The zeroization procedure is invoked when the operator exits FIPS mode. The procedure consists of overwriting configuration data including all CSPs. The operator must be in control of the module during the entire procedure to ensure that it has successfully completed. During the zeroization procedure, no other services are available.

6.3 Definition of Critical Security Parameters (CSPs)

The modules contain the following CSPs:

Table 15 - Private Keys and CSPs

CSP #	Key Name	Type	Description
1	Web interface private key	RSA	Decrypts TLS session key and provides authentication services (admin web interface, captive portal, SSL VPN portal)
2	TLS PreMaster Secret	TLS Secret	Secret value used to derive the TLS session keys
3	TLS DH Private Components	DH	Diffie Hellman (Group 14) 2048 bit private component used in key establishment
4	TLS-HMAC	HMAC-SHA-1	Authentication keys used in all https connections to the security module's web interface.
5	TLS session keys	AES, TDES	Used in all https connections to the security module's web interface.
6	SSH-Firewall private key	RSA	Used to identify the security appliance in SSH. The security modules support 512, 1024, and 2048 bit keys and only 2048 bit keys are supported in FIPS mode.
7	SSH-HMAC	HMAC-SHA-1	Authentication keys used in all SSH connections to the security module's command line interface.
8	SSH session keys	AES, TDES	Used in all SSH connections to the security module's command line interface.
9	SSH DH Private Components	DH	Diffie Hellman (Group 14) 2048 bit private component used in key establishment
10	S-S VPN IPsec/IKEv1 authentication	HMAC-SHA-1	Used to authenticate the peer in an IKE/IPsec tunnel connection.
11	S-S VPN IPsec/IKEv1 session key	AES, TDES	Used to encrypt IKE/IPsec data. These are AES (128 bit, 192 bit, 256 bit) or triple DES keys.
12	S-S VPN IPsec/IKEv1 Diffie Hellman Private Components	DH	Diffie Hellman (Group 14) 2048 bit private component used in key establishment
13	S-S VPN IPSEC pre-shared keys	Part of HMAC	Entered manually by an administrator in the CO role. Used in authentication.

CSP #	Key Name	Type	Description
14	RA VPN IPSec session key	AES-128	Used to encrypt remote access sessions utilizing IPSec.
15	RA VPN IPSec authentication HMAC	HMAC-SHA-1	Used in authentication of remote access IPSec data.
16	Firmware code integrity check	HMAC-SHA-256	Used to check the integrity of crypto-related code.
17	Firmware Content encryption key	AES-256	Used to decrypt firmware, software, and content.
18	CO, User, RA VPN Password	Password	Entered by the Operator.
19	File encryption key	AES-256	Used to encrypt crypto-related files on the firewall.
20	RNG seed key	AES	Seed key used in RNG.
21	RNG seed value		Seed used to initialize RNG.
22	DLP Private key	RSA	Used to encrypt DLP data. Only 2048 bit keys are supported.

5.3a Definition of Public Keys

The modules contain the following public keys:

Table 16 - Public Keys

Key Name	Type	Description
Web interface certificates	RSA-2048	Used to establish TLS sessions between firewall and user for web interface (management), captive portal, and remote access SSL VPN portal
CA certificate	RSA-2048	Used to trust a CA for SSL decryption sessions
Client CA certificate	RSA-2048	Used to verify client certificates for firewall administrators
Client OCSP verify CA certificate	RSA-2048	Used for certificate validation via OCSP
TLS peer public key	RSA-2048	Cert coming in from web server in outbound TLS decryption - used to encrypt the session key for client session with web server
TLS DH public components	DH – 2048 (Group 14)	Used in key agreement
SSH DH public components	DH – 2048 (Group 14)	Used in key agreement
SSH – Firewall public key	RSA-2048	Used firewall in authentication process

S-S VPN - IPSec/IKEv1 Diffie Hellman public component	DH – 2048 (Group 14)	Used in key agreement
Public key for firmware content load test	RSA-2048	Used to authenticate firmware and content to be installed on the firewall
DLP public key	RSA-2048	Used to encrypt data loss prevention data
Client public key	RSA-2048	Used to authenticate User, CO, or remote access VPN users

6.4 Definition of CSPs Modes of Access

Table 17 defines the relationship between access to CSPs and the different module services. The modes of access shown in the table are defined as:

- **R = Read**: The module reads the CSP. The read access is typically performed before the module uses the CSP.
- **W = Write**: The module writes the CSP. The write access is typically performed after a CSP is imported into the module, or the module generates a CSP, or the module overwrites an existing CSP.
- **Z = Zeroize**: The module zeroizes the CSP.

Table 17 - CSP Access Rights within Roles & Services

Role	Authorized Service	Mode	Cryptographic Key or CSP
CO	Security Configuration Management	RW	1, 2, 3, 4, 5, 6, 7, 8, 9, 16, 17, 18, 19, 20, 21, 22
CO	Other Configuration	RW	1, 2, 3, 4, 5, 6, 7, 8, 9,
User, CO	Show Status	R	1, 2, 3, 4, 5, 6, 7, 8, 9
Unauthenticated	Zeroize	Z	All CSPs are zeroized.
S-S VPN	VPN	R	10, 11, 12, 13
RA VPN	VPN	R	1, 2, 3, 4, 5, 14, 15
CO	Firmware Update	RW	17
Unauthenticated	Self-Tests	W	20, 21
Unauthenticated	Show Status (LEDs)	N/A	N/A

7 Operational Environment

The FIPS 140-2 Area 6 Operational Environment requirements are not applicable because the PA-500, PA-2000 Series, and PA-4000 Series Firewalls do not contain modifiable operational environments.

8 Security Rules

The module design corresponds to the module security rules. This section documents the security rules enforced by the cryptographic module to implement the security requirements of this FIPS 140-2 Level 2 module.

1. The cryptographic module shall provide four distinct operator roles. These are the User role, Remote Access VPN role, Site-to-site VPN role, and the Cryptographic Officer role.
2. The cryptographic module shall provide identity-based authentication.
3. The cryptographic module shall clear previous authentications on power cycle.
4. When the module has not been placed in a valid role, the operator shall not have access to any cryptographic services.
5. The cryptographic module shall perform the following tests
 - A. Power up Self-Tests
 1. Cryptographic algorithm tests
 - a. TDES Known Answer Tests
 - b. AES Known Answer Test
 - c. DSA Pairwise Consistency Test
 - d. RSA Known Answer Test
 - e. HMAC-SHA-1, SHA-2 Known Answer Test
 - f. SHA-1 Known Answer Test
 - g. RNG Known Answer Test
 - h. NDRNG Test
 2. Firmware Integrity Test – A 128 bit EDC (using MD5) is calculated on non-security related code. Security related code is verified with HMAC-SHA-256.
 - B. Critical Functions Tests
N/A
 - C. Conditional Self-Tests
 1. Continuous Random Number Generator (RNG) test – performed on NDRNG and RNG, 128 bits
 2. RSA Pairwise Consistency Test (when a key generation fails, the error message displayed is “Cannot verify key and certificate. Maybe the passphrase is incorrect.”)

3. Software/Firmware Load Test – Verify signature on software/firmware at time of load
6. The operator shall be capable of commanding the module to perform the power-up self-test by cycling power of the module.
7. Power-up self tests do not require any operator action.
8. Data output shall be inhibited during key generation, self-tests, zeroization, and error states.
9. Status information does not contain CSPs or sensitive data that if misused could lead to a compromise of the module.
10. The module ensures that the seed and seed key inputs to the Approved RNG are not equal.
11. There are no restrictions on which keys or CSPs are zeroized by the zeroization service.
12. The module maintains separation between concurrent operators.
13. The module does not support a maintenance interface or role.
14. The module does not have any external input/output devices used for entry/output of data.
15. The module does not enter or output plaintext CSPs.
16. The module does not output intermediate key generation values.

Vendor imposed security rules:

1. The module does not support the update of the logical serial number or vendor ID.
2. The module does not provide access to revenue related data structures while plaintext CSPs are present.
3. If the cryptographic module remains inactive in any valid role for the administrator specified time interval, the module automatically logs out the operator.
4. The module enforces a timed access protection mechanism that supports at most ten authentication attempts per minute. After the administrator specified number of consecutive unsuccessful Password validation attempts have occurred, the cryptographic module shall enforce a wait period of at least 1 minute before any more login attempts can be attempted. This wait period shall be enforced even if the module power is momentarily removed.

9 Physical Security Policy

9.1 Physical Security Mechanisms

The multi-chip standalone modules are production quality containing standard passivation. Chip components are protected by an opaque enclosure. There are tamper evident seals that are applied on the modules by the Crypto-Officer. The seals prevent removal of the opaque enclosure without evidence. The Crypto-Officer should inspect the seals for evidence of tamper every 30 days. If the seals show evidence of tamper, the Crypto-Officer should assume that the modules have been compromised and contact Customer Support.

Note: For ordering information, see Table 2 for FIPS kit part numbers and versions.

Refer to Appendix A for instructions on installation of the tamper seals and opacity shields. The locations of the nine (9) tamper evident seals implemented on the PA-500 are shown in Figure 13 through Figure 16 below.

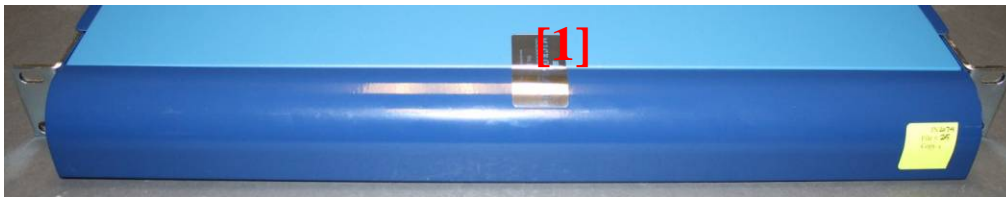

Figure 13 - PA-500 Front Tamper Seal Placement (1)

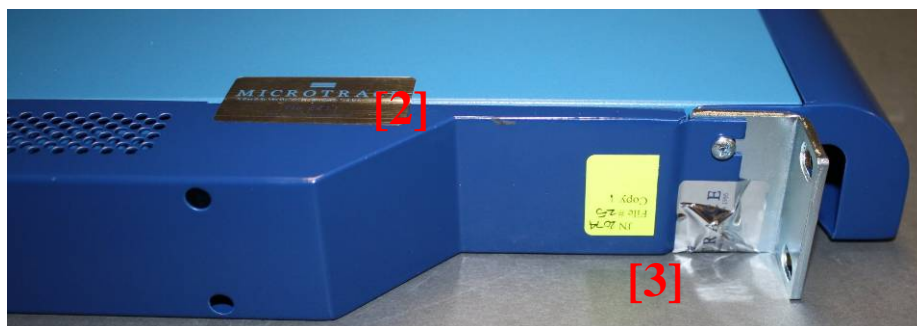

Figure 14 - PA-500 Left Side Tamper Seal Placement (2)



Figure 15 - PA-500 Right Side Tamper Seal Placement (2)



Figure 16 - PA-500 Rear Tamper Seal Placement (4)

Refer to Appendix B for instructions on installation of the tamper seals and opacity shields. The locations of the nine (9) tamper evident seals on the PA-2000 Series modules are shown in Figure 17 through Figure 20 below.

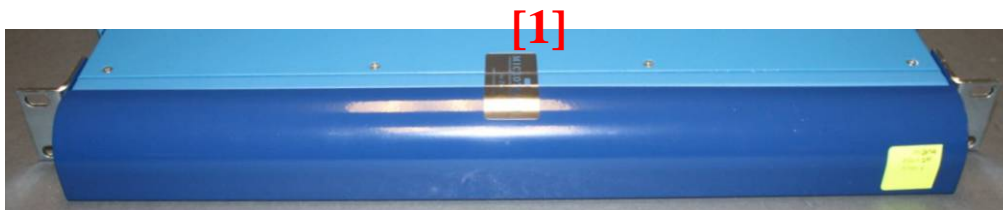

Figure 17 - PA-2000 Series Front Tamper Seal Placement (1)



Figure 18 - PA-2000 Series Left Side Tamper Seal Placement (3)



Figure 19 - PA-2000 Series Right Side Tamper Seal Placement (3)



Figure 20 - PA-2000 Series Rear Tamper Seal Placement (2)

Refer to Appendix C for instructions on installation of the tamper seals and opacity shields. The locations of the ten (10) tamper evident seals implemented on the PA-4000 Series modules are shown in Figure 21 through Figure 24 below.

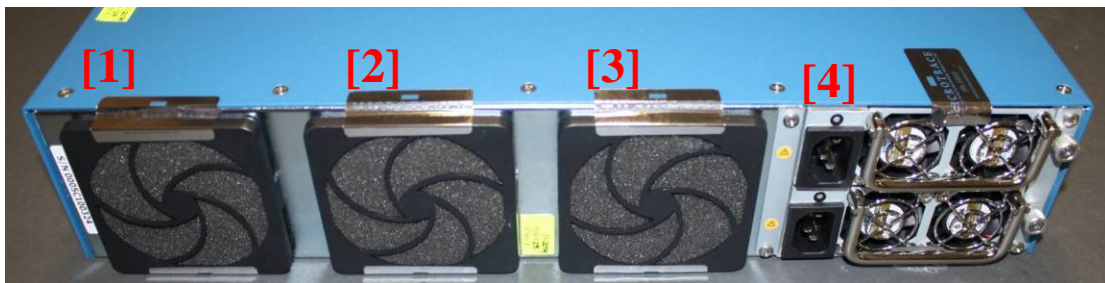

Figure 21 - PA-4000 Series Rear Tamper Seal Placement - From Top (4)

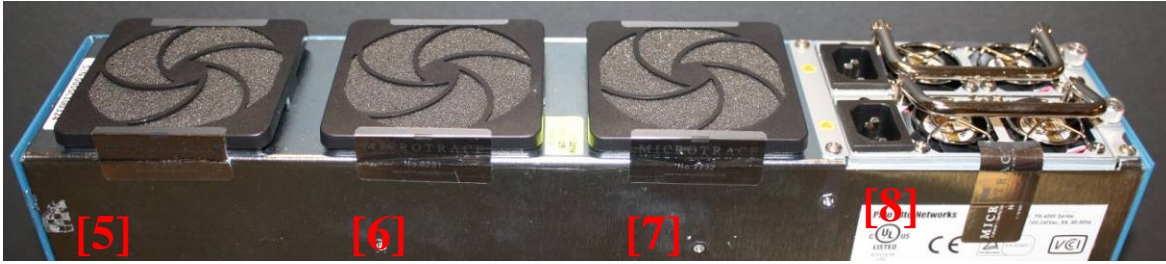

Figure 22 - PA-4000 Series Rear Side Tamper Seal Placement – From Underside (4)

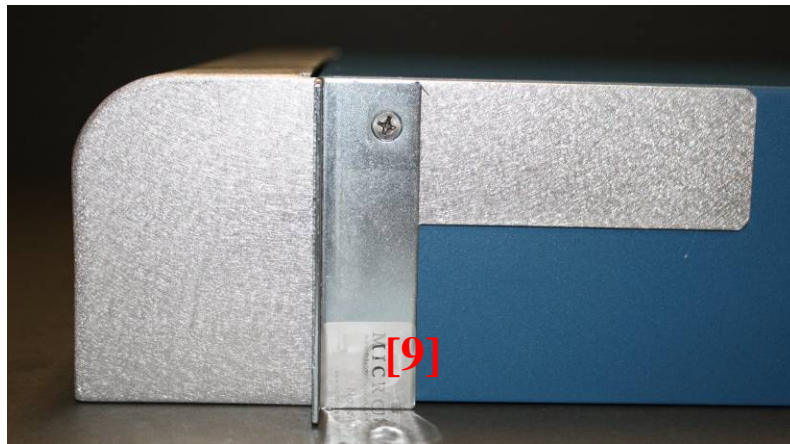

Figure 23 - PA-4000 Series Right Side Tamper Seal Placement (1)

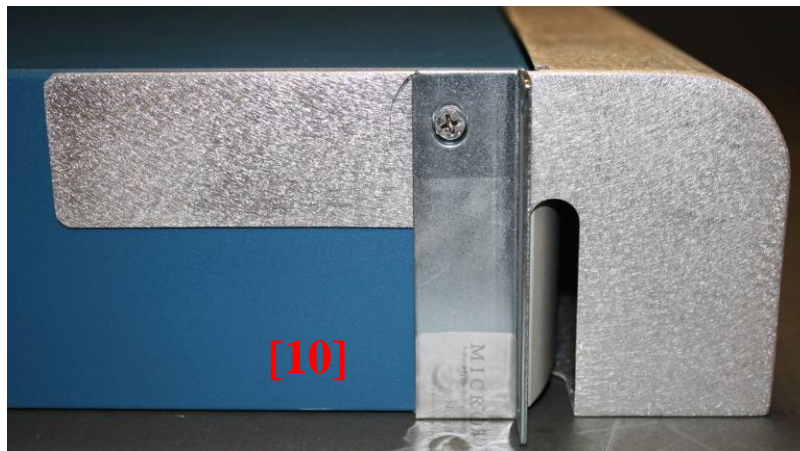

Figure 24 - PA-4000 Series Left Side Tamper Seal Placement (1)

9.2 Operator Required Actions

Table 18 - Inspection/Testing of Physical Security Mechanisms

Model	Physical Security Mechanisms	Recommended Frequency of Inspection/Test	Inspection/Test Guidance Details
PA-4060, PA-4050, PA-4020, PA-2050, PA-2020, PA-500	Tamper Evident Seals	30 Days	<i>Verify integrity of tamper evident seals in the locations identified in the FIPS Kit Installation Guide</i>
PA-4020, PA-4050, PA-4060	Front Cover	30 days	<i>Verify that front cover has not been deformed from its original shape thereby reducing its effectiveness</i>
PA-500, PA-2020, PA-2050	Front Cover and Side Plenums	30 days	<i>Verify that front cover and side plenums have not been deformed from their original shape thereby reducing their effectiveness</i>

10 Mitigation of Other Attacks Policy

The module has not been designed to mitigate any specific attacks outside of the scope of FIPS 140-2, so these requirements are not applicable.

11 References

[FIPS 140-2] FIPS Publication 140-2 *Security Requirements for Cryptographic Modules*

12 Definitions and Acronyms

API – Application Programming Interface

App-ID – Application Identification - Palo Alto Networks' ability to identify applications and apply security policy based on the ID rather than the typical port and protocol-based classification.

BGP – Border Gateway protocol – Dynamic routing protocol

CA – Certificate authority

Content-ID – Content Identification – Palo Alto Networks' threat prevention features including Antivirus, Antispyware, and Intrusion Prevention.

CO – Cryptographic Officer

DB9 – Console port connector

DLP – Data loss prevention

Gbps – Gigabits per second

HA – High Availability

IKE – Internet Key Exchange

IP – Internet Protocol

IPSec – Internet Protocol Security

LDAP – Lightweight Directory Access Protocol

LED – Light Emitting Diode

NDRNG – Non-deterministic random number generator

OCSP – Online Certificate Status Protocol

OSPF – Open Shortest Path First – Dynamic routing protocol

PAN-OS – Palo Alto Networks' Operating System

QoS – Quality of Service

RA VPN – Remote Access Virtual Private Network

RIP – Routing Information Protocol – Dynamic routing protocol

RJ45 – Networking Connector

RNG – Random number generator

S-S VPN – Site to site Virtual Private Network

SFP – Small Form-factor Pluggable Transceiver

SSL – Secure Sockets Layer

TLS – Transport Layer Security

USB – Universal Serial Bus

User-ID – User Identification – Palo Alto Networks' ability to apply security policy based on who initiates the traffic rather than the typical IP-based approach.

VPN – Virtual Private Network

XFP – 10 Gigabit Small Form Factor Pluggable Transceiver

XML – Extensible Markup Language

13 Appendix A – PA-500 – FIPS Accessories/Tamper Seal Installation

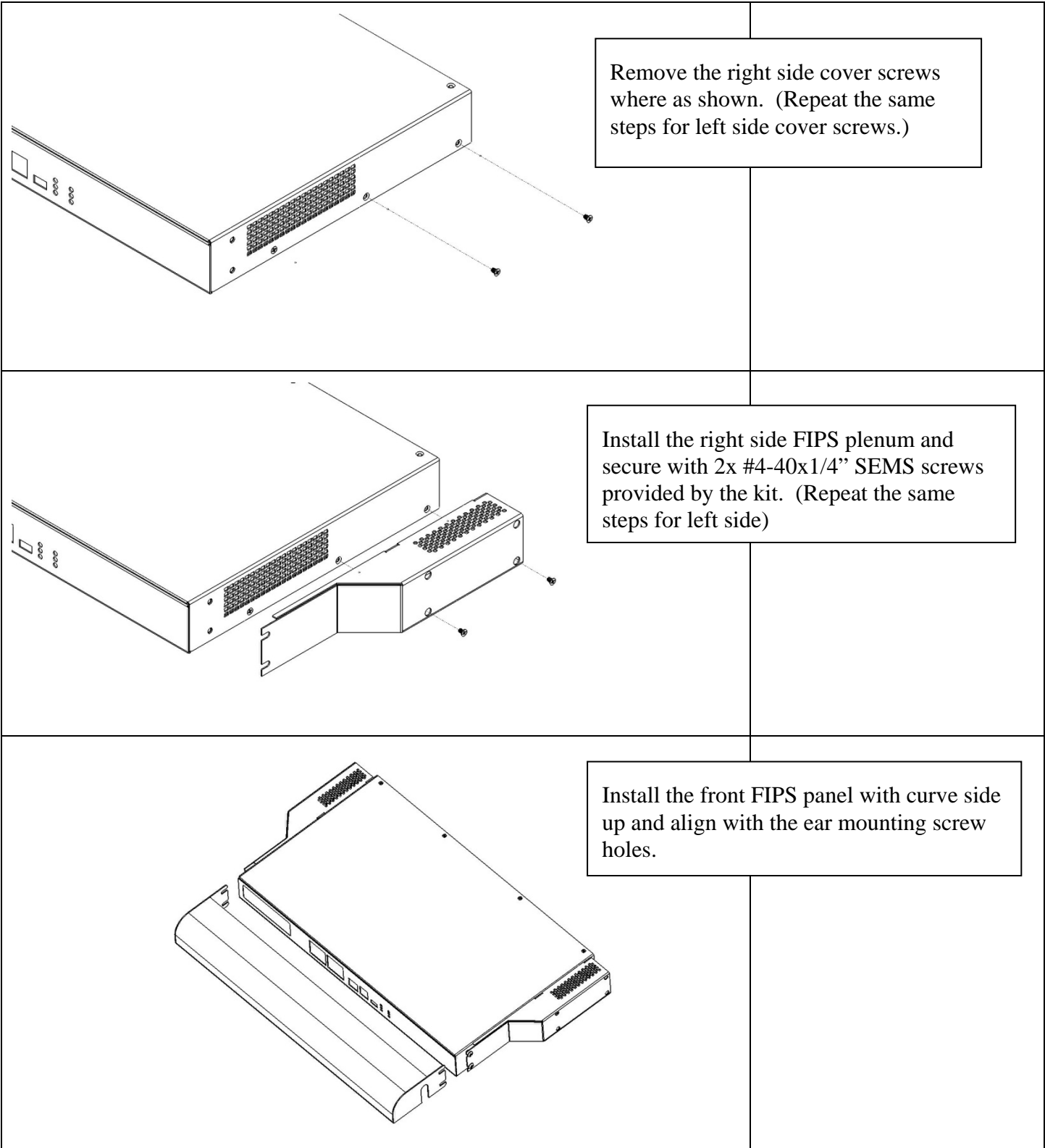

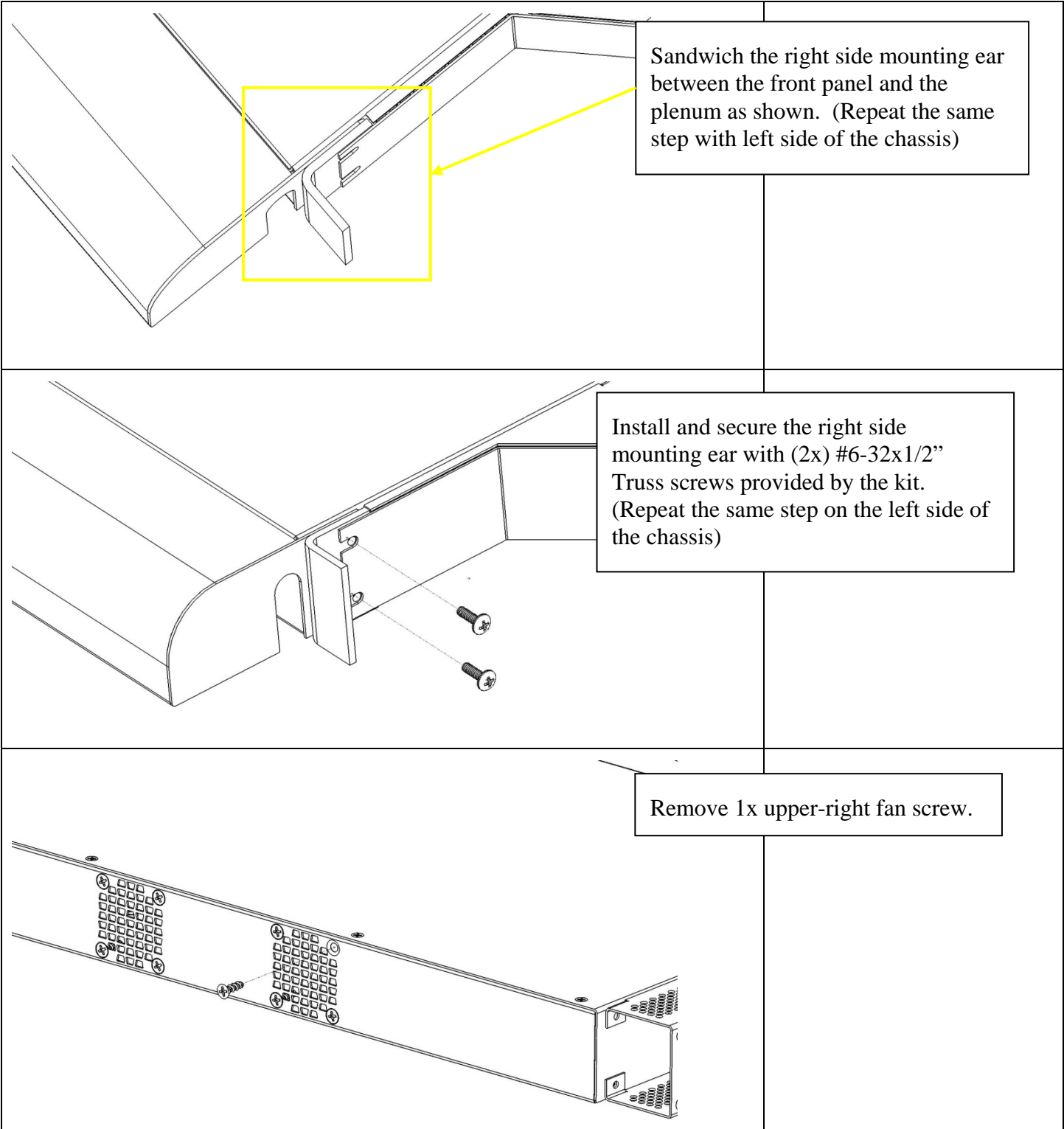

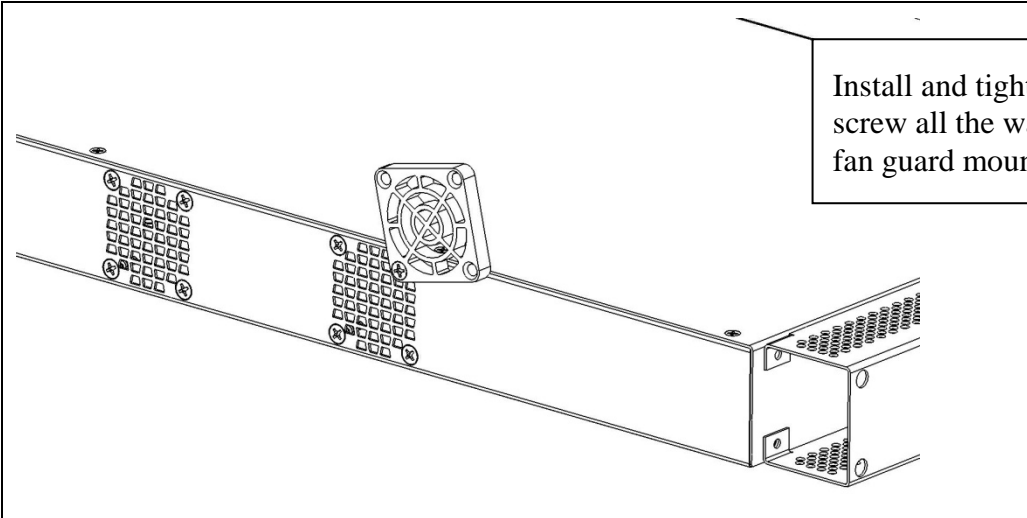

Install and tighten (do not tighten the screw all the way) the screw to one of the fan guard mounting holes as shown.

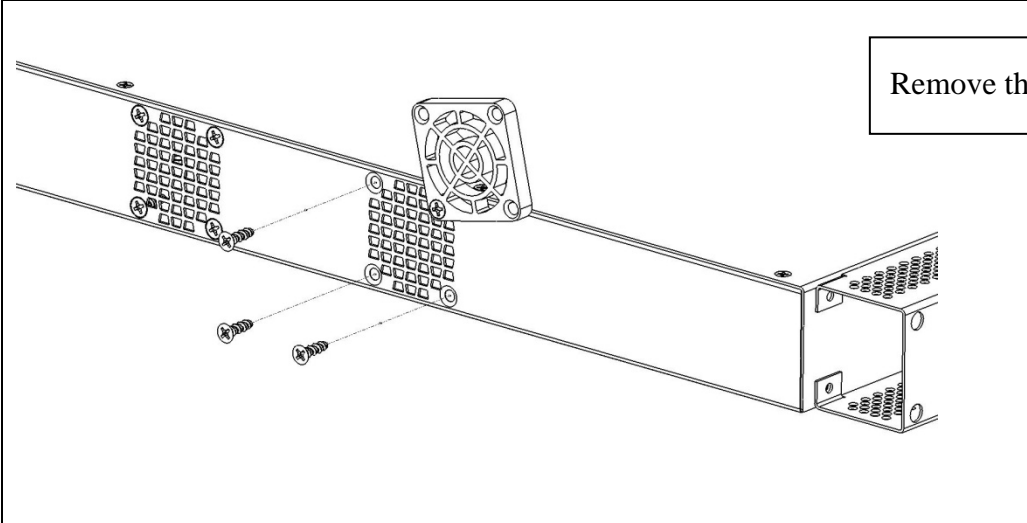

Remove the other 3x fan screws

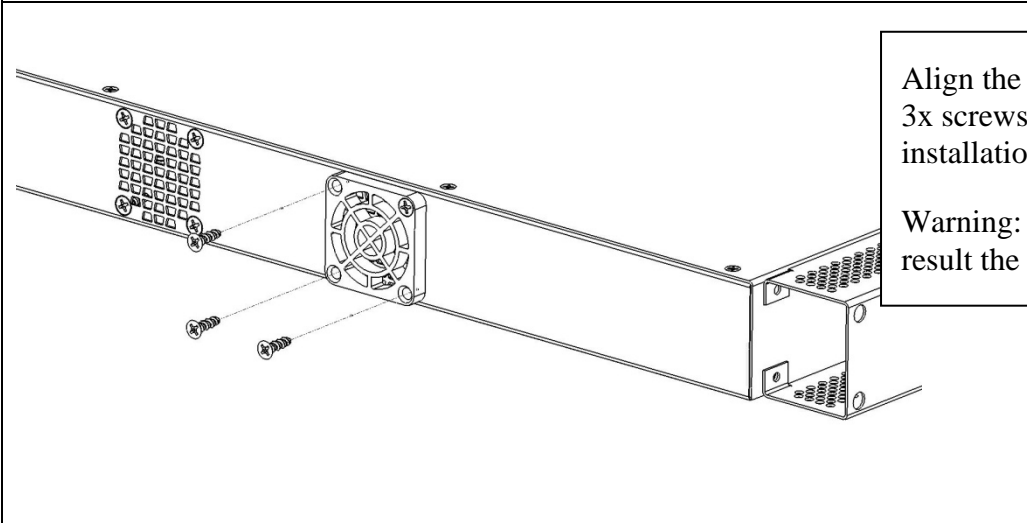

Align the fan guard and secure with 3x screws as shown. Repeat above installation steps for the other fan.

Warning: Over tighten the screw will result the fan guard to crack.

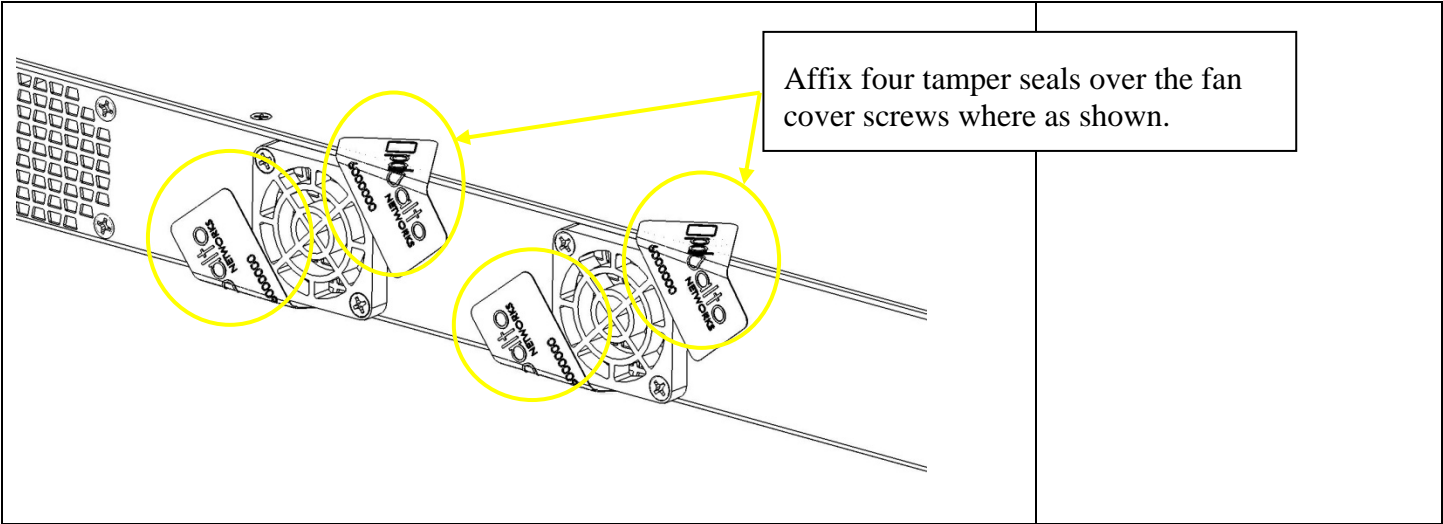

Affix four tamper seals over the fan cover screws where as shown.

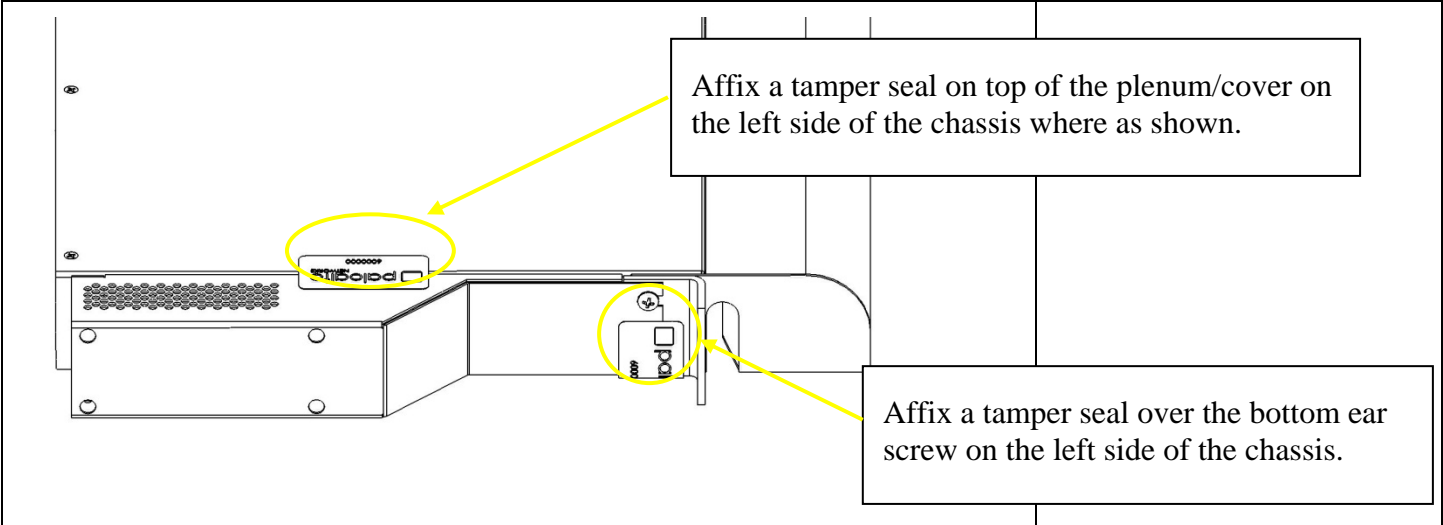

Affix a tamper seal on top of the plenum/cover on the left side of the chassis where as shown.

Affix a tamper seal over the bottom ear screw on the left side of the chassis.

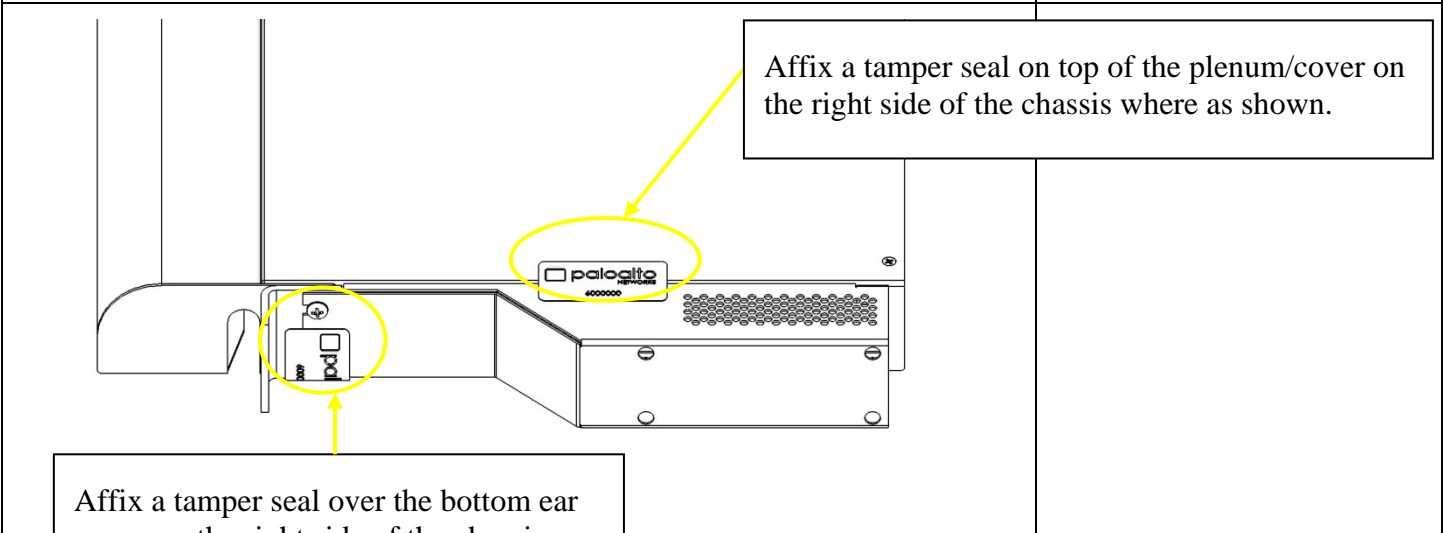

Affix a tamper seal on top of the plenum/cover on the right side of the chassis where as shown.

Affix a tamper seal over the bottom ear screw on the right side of the chassis.

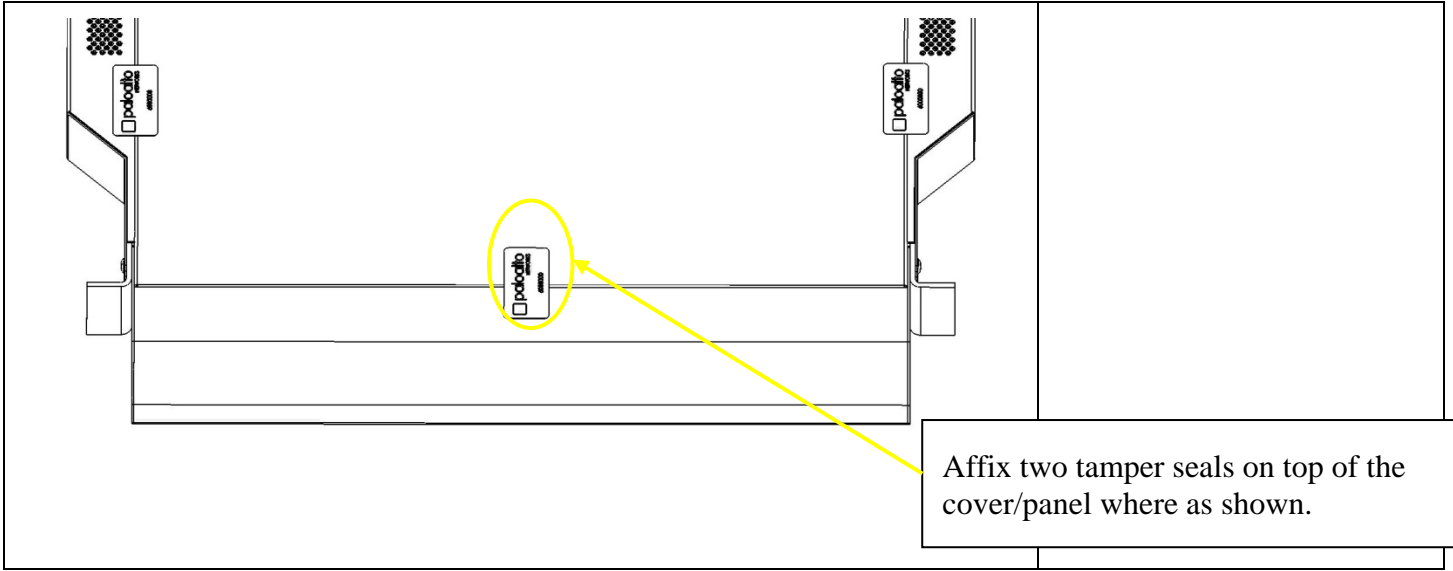

14 Appendix B - PA-2000 Series – FIPS Accessories/Tamper Seal Installation

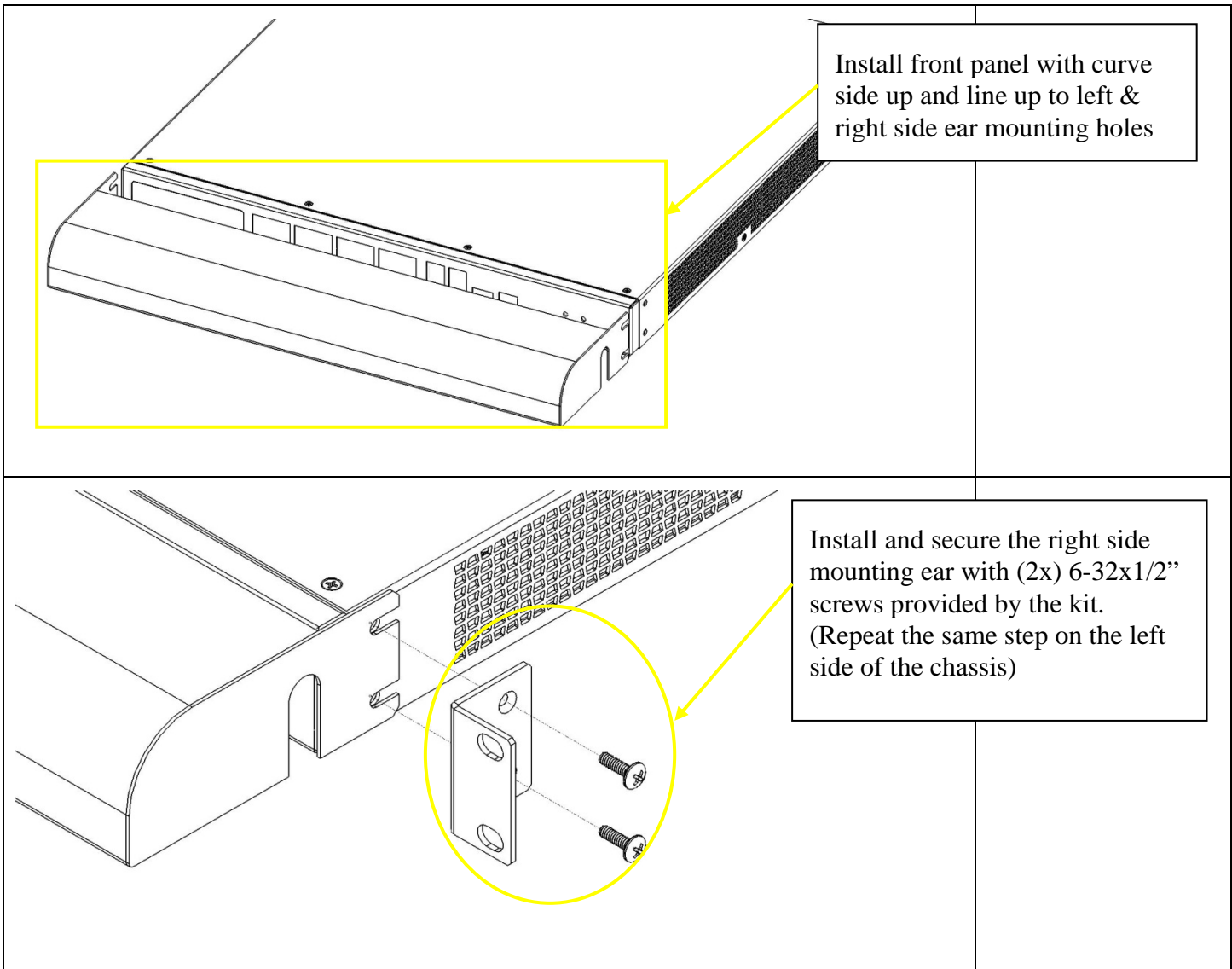

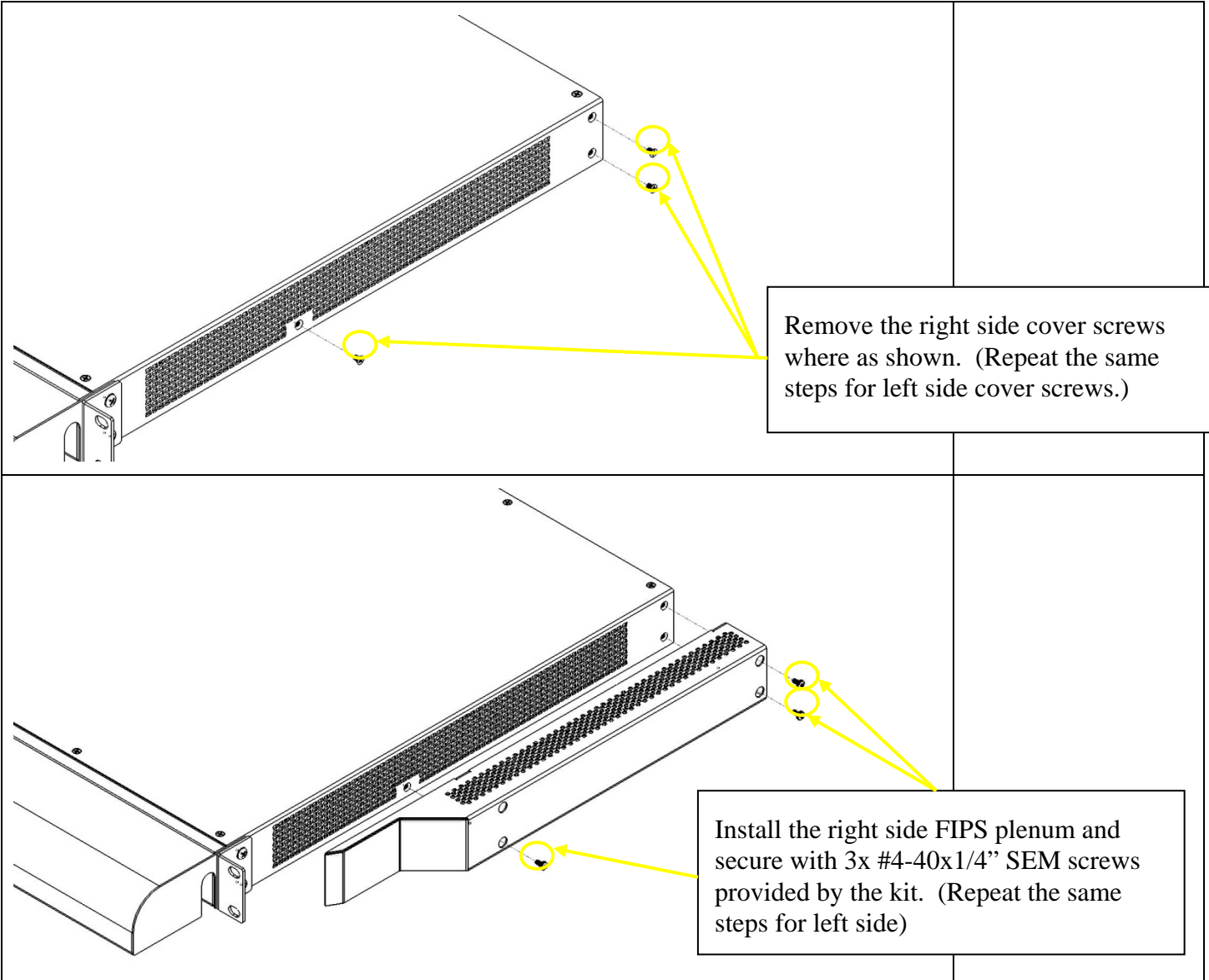

Affix a tamper seal to cover the right side bottom ear mounting bracket screw. (Repeat the same steps for the left side)

Affix a tamper seal at right side of the chassis between the top cover and the FIPS plenum. Affix another one between the bottom chassis and the FIPS plenum where as shown. (Repeat the same steps for left side)

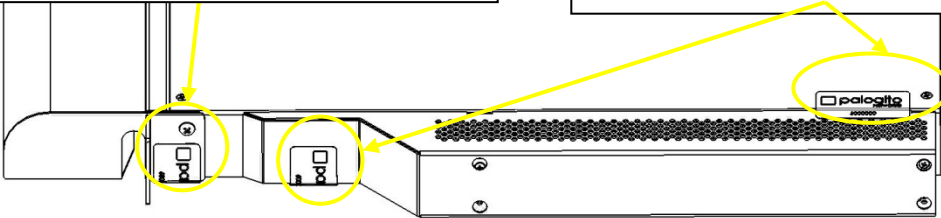

Affix a tamper seal on the top cover/rear chassis where as shown.

Affix a tamper seal on the top cover/HDD tray where as

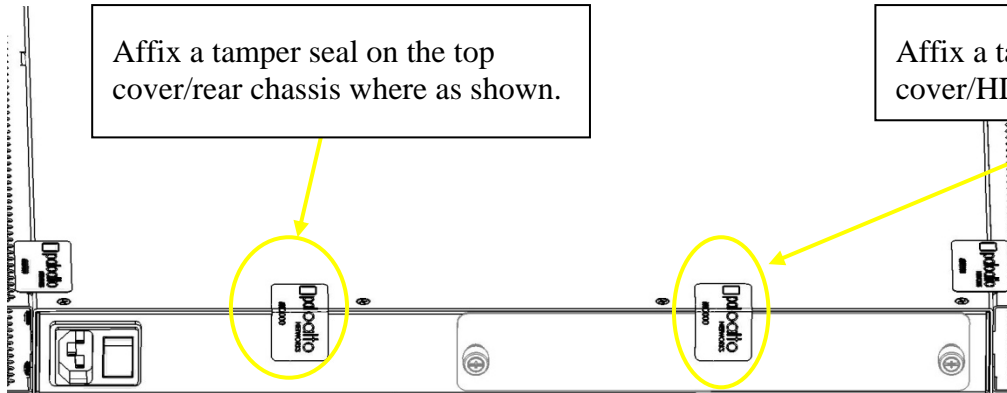

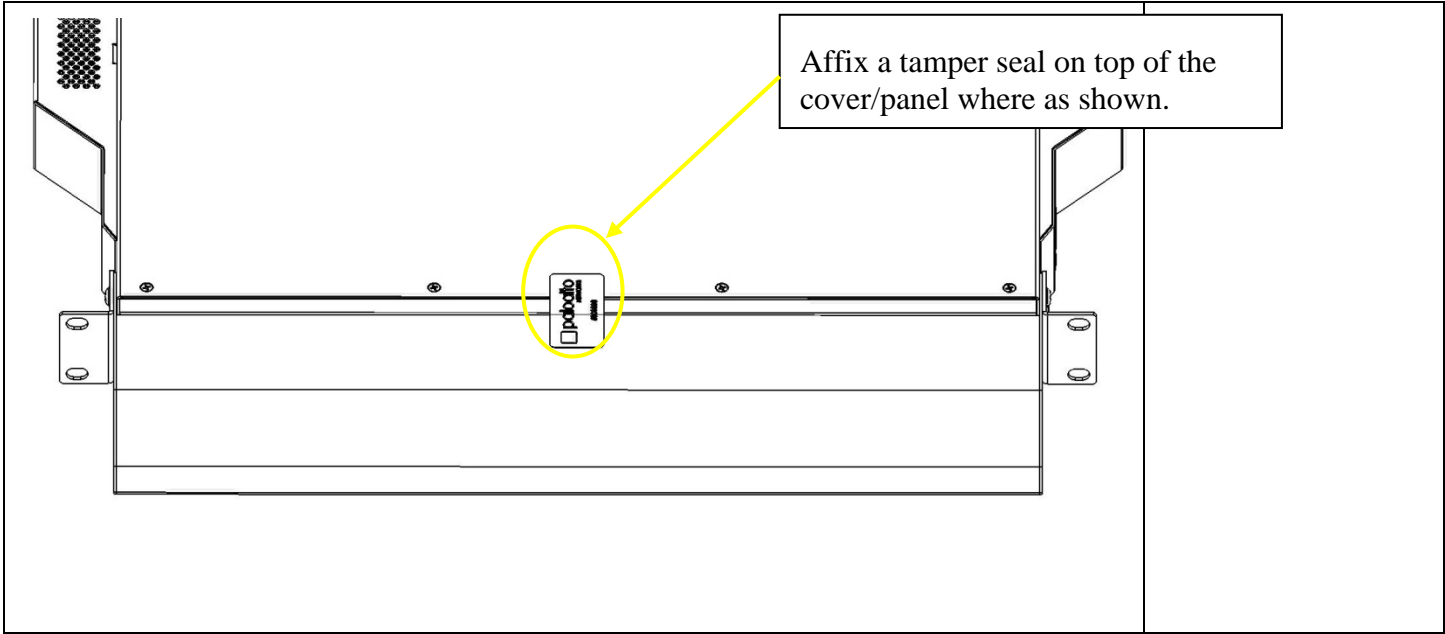

15 Appendix C - PA-4000 Series – FIPS Accessories/Tamper Seal Installation

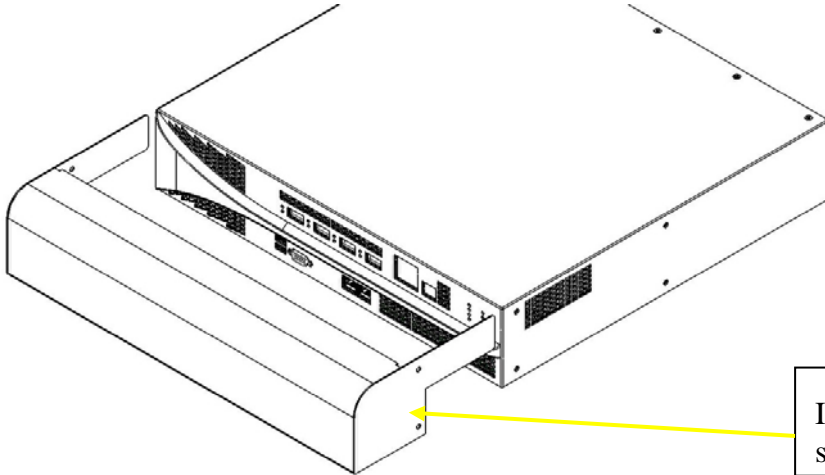

Install the front panel FIPS plenum as shown.

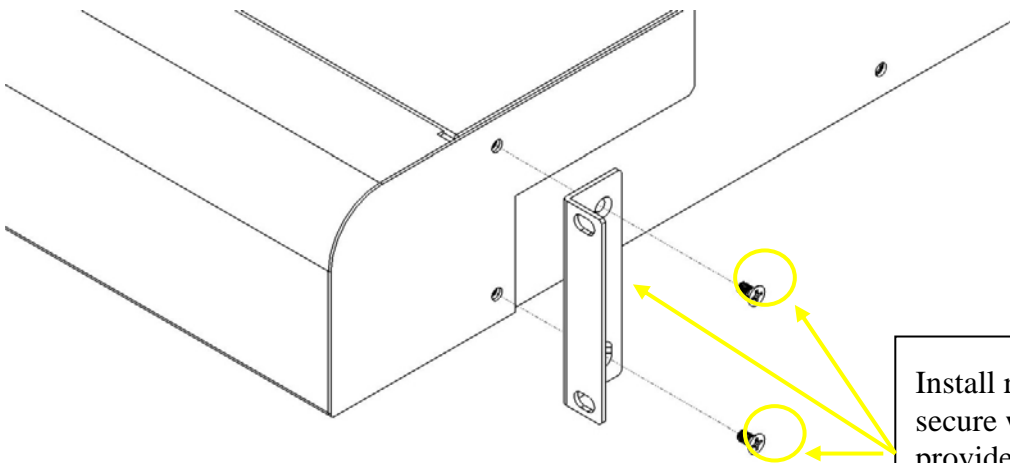

Install right mounting bracket and secure with (2x) 8-32x3/8" screws provided by the kit. Repeat the same steps for the right mounting bracket.

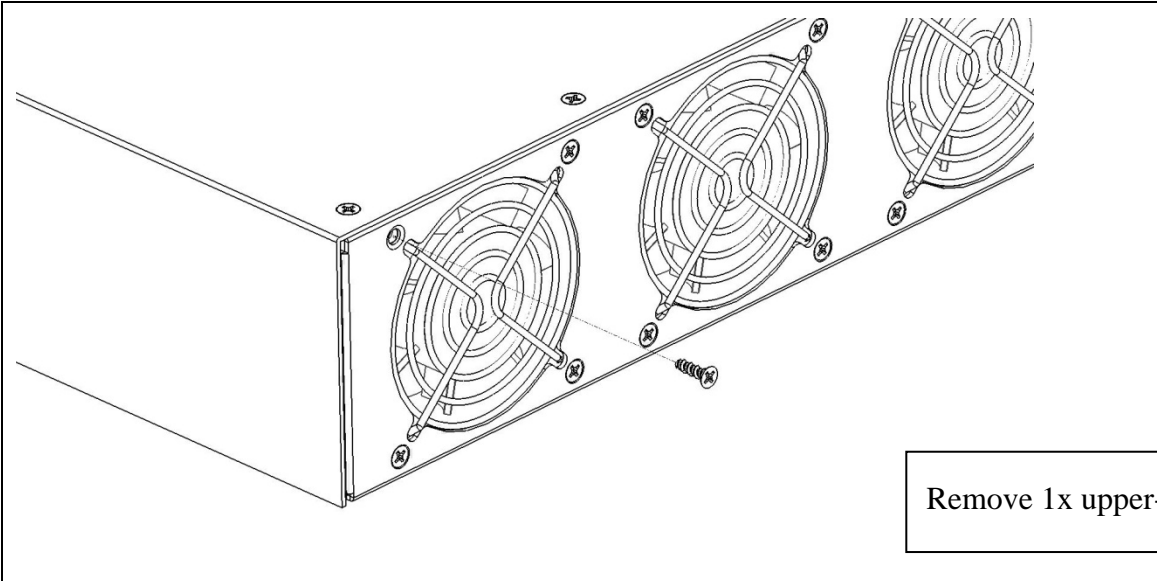

Remove 1x upper-left fan screw.

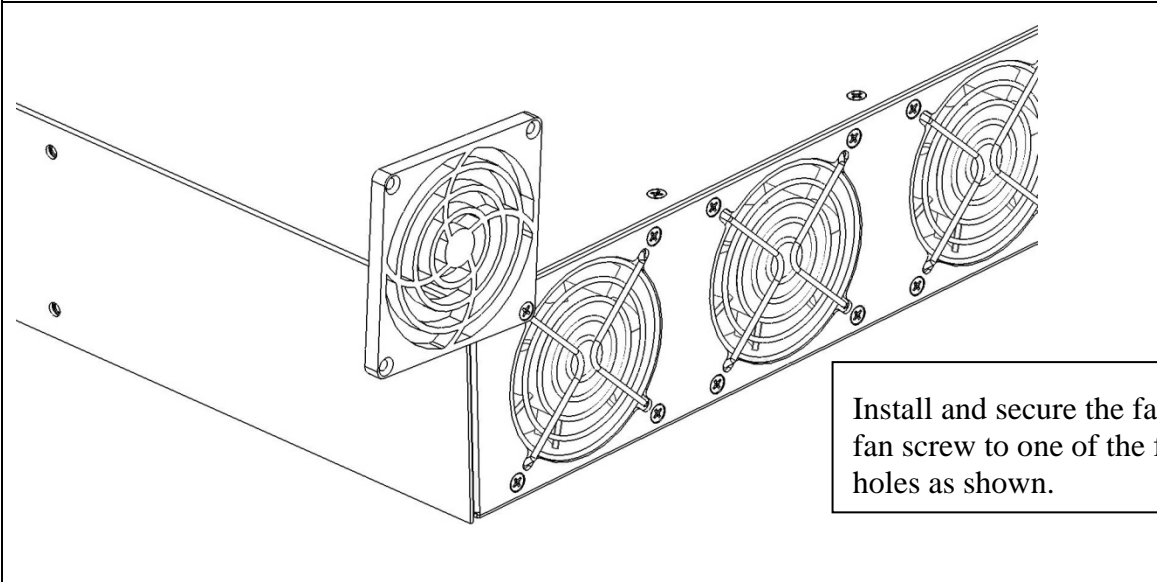

Install and secure the fan guard with the fan screw to one of the fan guard mounting holes as shown.

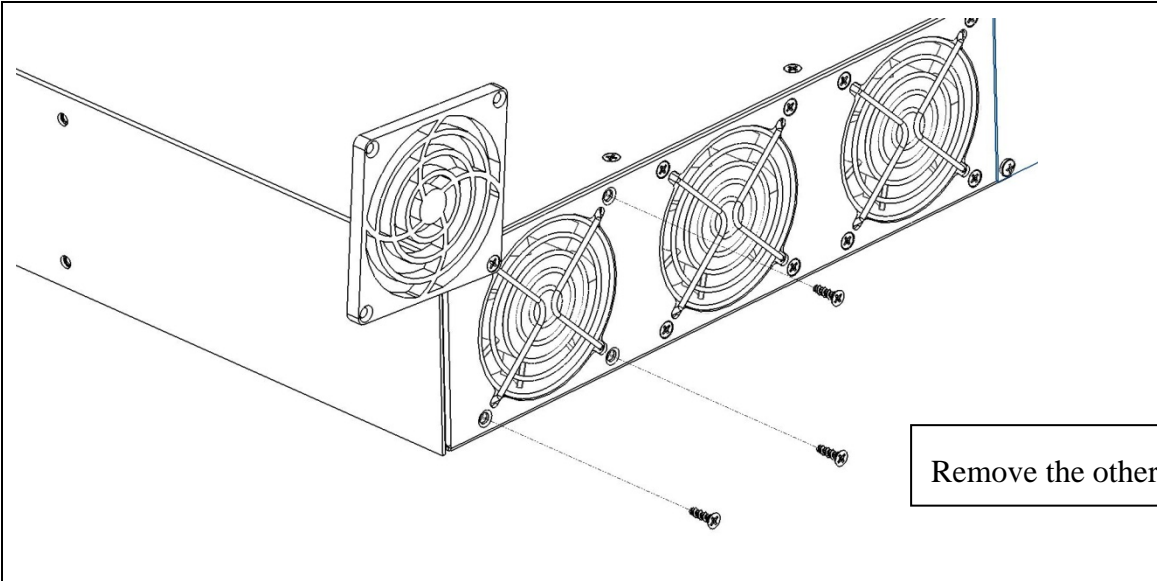

Remove the other 3x fan screws

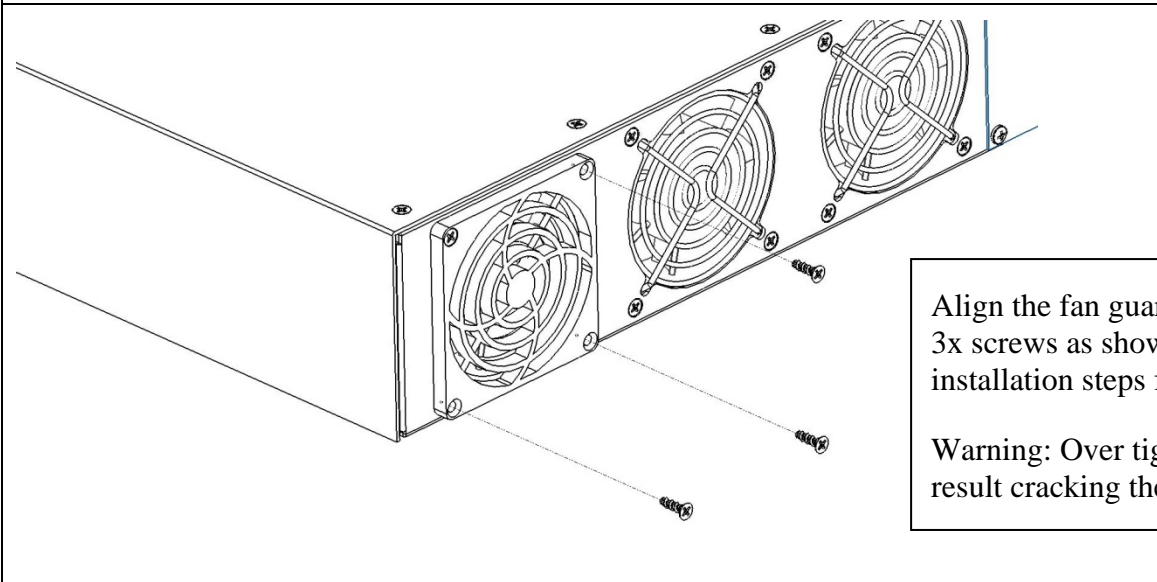

Align the fan guard and secure with 3x screws as shown. Repeat above installation steps for the other fans.

Warning: Over tighten the screw will result cracking the fan guard.

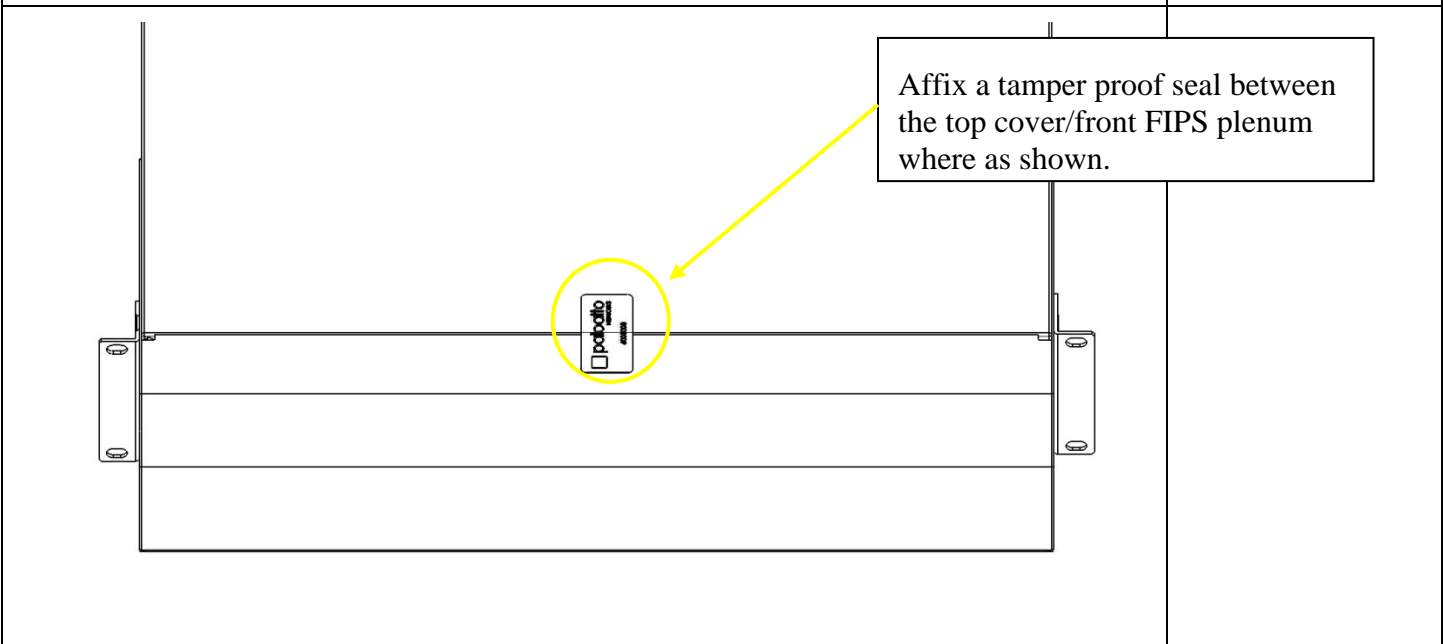
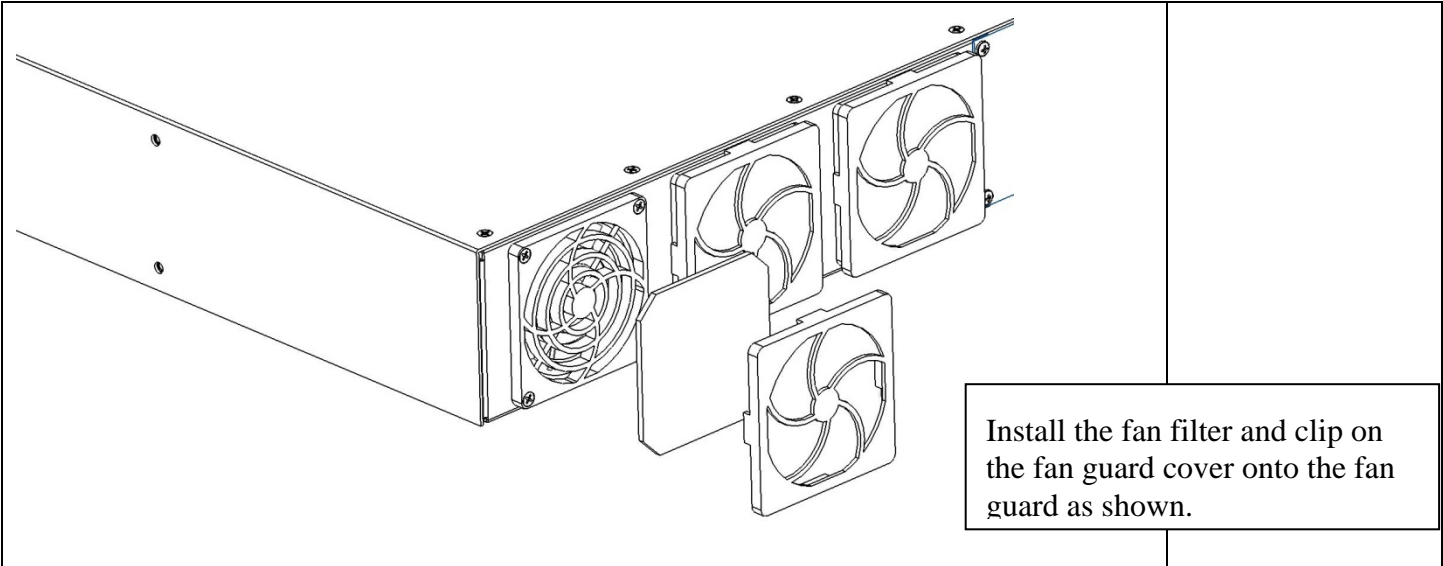

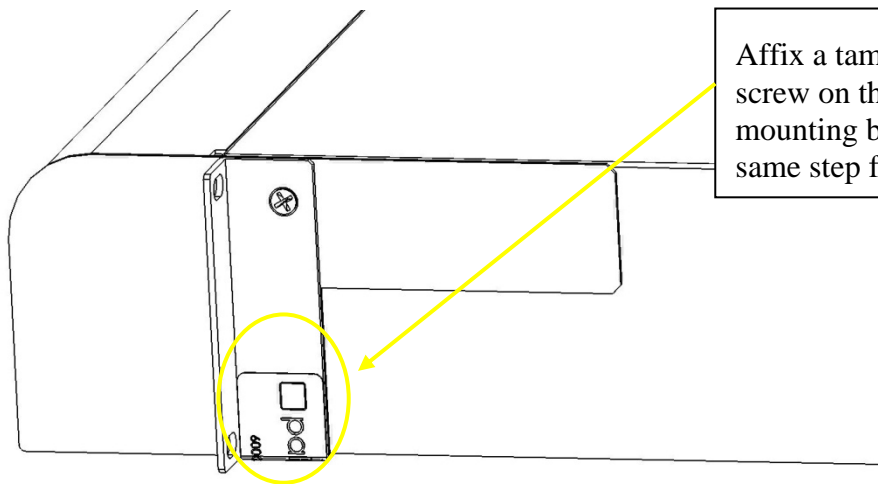

Affix a tamper proof seal over screw on the lower right side mounting bracket. Repeat the same step for left side bracket.

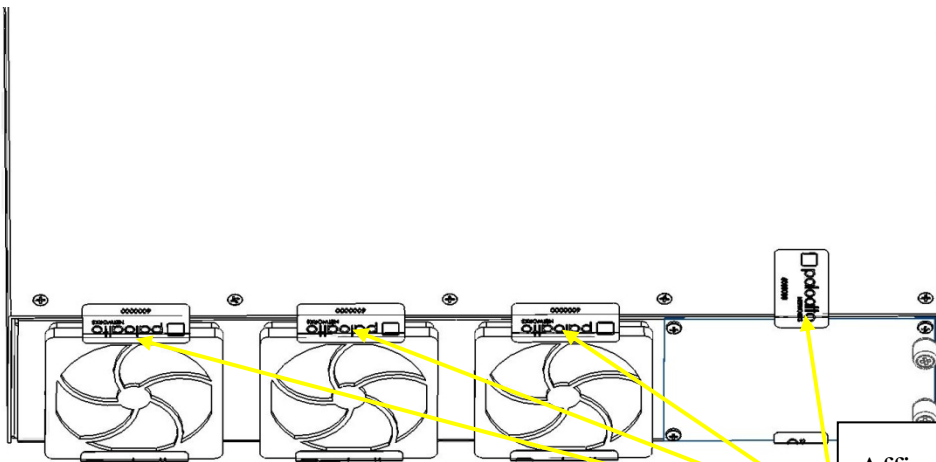

Affix four tamper proof seals between the top cover/fan guards and top cover/PSU where as shown.

