

POWERMATIC[®]

Operating Instructions and Parts Manual 8-inch Jointer Models 60C and 60HH



Powermatic
427 New Sanford Rd.
LaVergne, TN 37086
Ph.: 800-274-6848
www.powermatic.com

Part No. M-1610084
Revision B2 02/2014
Copyright © 2014 Powermatic

Warranty and Service

Powermatic warrants every product it sells against manufacturers' defects. If one of our tools needs service or repair, please contact Technical Service by calling 1-800-274-6846, 8AM to 5PM CST, Monday through Friday.

Warranty Period

The general warranty lasts for the time period specified in the literature included with your product or on the official Powermatic branded website.

- Powermatic products carry a limited warranty which varies in duration based upon the product. (See chart below)
- Accessories carry a limited warranty of one year from the date of receipt.
- Consumable items are defined as expendable parts or accessories expected to become inoperable within a reasonable amount of use and are covered by a 90 day limited warranty against manufacturer's defects.

Who is Covered

This warranty covers only the initial purchaser of the product from the date of delivery.

What is Covered

This warranty covers any defects in workmanship or materials subject to the limitations stated below. This warranty does not cover failures due directly or indirectly to misuse, abuse, negligence or accidents, normal wear-and-tear, improper repair, alterations or lack of maintenance.

Warranty Limitations

Woodworking products with a Five Year Warranty that are used for commercial or industrial purposes default to a Two Year Warranty. Please contact Technical Service at 1-800-274-6846 for further clarification.

How to Get Technical Support

Please contact Technical Service by calling 1-800-274-6846. **Please note that you will be asked to provide proof of initial purchase when calling.** If a product requires further inspection, the Technical Service representative will explain and assist with any additional action needed. Powermatic has Authorized Service Centers located throughout the United States. For the name of an Authorized Service Center in your area call 1-800-274-6846 or use the Service Center Locator on the Powermatic website.

More Information

Powermatic is constantly adding new products. For complete, up-to-date product information, check with your local distributor or visit the Powermatic website.

How State Law Applies

This warranty gives you specific legal rights, subject to applicable state law.

Limitations on This Warranty

POWERMATIC LIMITS ALL IMPLIED WARRANTIES TO THE PERIOD OF THE LIMITED WARRANTY FOR EACH PRODUCT. EXCEPT AS STATED HEREIN, ANY IMPLIED WARRANTIES OF MERCHANTABILITY AND FITNESS FOR A PARTICULAR PURPOSE ARE EXCLUDED. SOME STATES DO NOT ALLOW LIMITATIONS ON HOW LONG AN IMPLIED WARRANTY LASTS, SO THE ABOVE LIMITATION MAY NOT APPLY TO YOU.

POWERMATIC SHALL IN NO EVENT BE LIABLE FOR DEATH, INJURIES TO PERSONS OR PROPERTY, OR FOR INCIDENTAL, CONTINGENT, SPECIAL, OR CONSEQUENTIAL DAMAGES ARISING FROM THE USE OF OUR PRODUCTS. SOME STATES DO NOT ALLOW THE EXCLUSION OR LIMITATION OF INCIDENTAL OR CONSEQUENTIAL DAMAGES, SO THE ABOVE LIMITATION OR EXCLUSION MAY NOT APPLY TO YOU.

Powermatic sells through distributors only. The specifications listed in Powermatic printed materials and on the official Powermatic website are given as general information and are not binding. Powermatic reserves the right to effect at any time, without prior notice, those alterations to parts, fittings, and accessory equipment which they may deem necessary for any reason whatsoever.

Product Listing with Warranty Period

90 Days – Parts; Consumable items
1 Year – Motors, Machine Accessories
2 Year – Woodworking Machinery used for industrial or commercial purposes
5 Year – Woodworking Machinery

NOTE: Powermatic is a division of JPW Industries, Inc. References in this document to Powermatic also apply to JPW Industries, Inc., or any of its successors in interest to the Powermatic brand.

Table of Contents

Warranty and Service.....	2
Table of Contents.....	3
Warning.....	4
Introduction.....	6
Specifications.....	6
Features and Terminology - 60C and 60HH Jointers.....	7
Unpacking.....	8
Assembly.....	9
Assembling Jointer to Stand.....	9
Cutterhead Guard.....	9
Aligning Pulleys.....	10
Installing Drive Belt.....	10
Installing Belt Guard and Door.....	11
Installing Switch Arm.....	11
Installing Dust Chute.....	11
Installing Fence Handwheel.....	12
Knife Gauge Assembly (<i>model 60C only</i>).....	12
Storing the Push Blocks.....	12
Electrical Connections.....	12
Extension Cords.....	14
Adjustments.....	14
Installing and Adjusting Knives (<i>Straight Cutterhead only</i>).....	14
Replacing and Rotating Knife Inserts (<i>Helical Cutterhead Only</i>).....	16
Leveling Tables.....	17
Adjusting Depth of Cut.....	18
Infeed Table Depth Stop.....	18
Setting Outfeed Table.....	18
Spring Cutting.....	19
Fence Movement.....	19
Fence Stops.....	20
Operating Controls.....	21
Basic Jointer Operation.....	22
Jointing Short or Thin Work.....	22
Direction of Grain.....	22
Hand Placement.....	22
Surfacing.....	22
Jointing Warped Surfaces.....	23
Edge Jointing.....	23
Beveling.....	23
Skewing (Shear Cutting).....	24
Taper Cuts.....	24
Rabbeting.....	25
Maintenance.....	25
Sharpening Knives (<i>model 60C only</i>).....	26
Cutterhead Maintenance.....	26
Table Removal.....	27
Troubleshooting – Mechanical and Electrical Problems.....	28
Troubleshooting – Operating Problems.....	30
Replacement Parts.....	31
Parts List: Base Assembly (60C and 60HH).....	31
Base Assembly (60C and 60HH).....	33
Parts List: Fence Assembly (60C and 60HH).....	34
Fence Assembly (60C and 60HH).....	35
Parts List: Straight Cutterhead Assembly (60C only).....	36
Parts List: Helical Cutterhead Assembly (60HH only).....	37
Parts List: Stand Assembly (60C and 60HH).....	38
Stand Assembly (60C and 60HH).....	40
Electrical Connections – Single Phase, 230 Volt.....	41
Electrical Connections – 3 Phase, 230 Volt.....	42
Electrical Connections – 3 Phase, 460 Volt.....	43

Warnings

1. Read and understand the entire owner's manual before attempting assembly or operation.
2. Read and understand the warnings posted on the machine and in this manual. Failure to comply with all of these warnings may cause serious injury.
3. Replace the warning labels if they become obscured or removed.
4. This jointer is designed and intended for use by properly trained and experienced personnel only. If you are not familiar with the proper and safe operation of a jointer, do not use until proper training and knowledge have been obtained.
5. Do not use this jointer for other than its intended use. If used for other purposes, Powermatic disclaims any real or implied warranty and holds itself harmless from any injury that may result from that use.
6. Always wear approved safety glasses/face shields while using this jointer. Everyday eyeglasses only have impact resistant lenses; they are not safety glasses.
7. Before operating this jointer, remove tie, rings, watches and other jewelry, and roll sleeves up past the elbows. Remove all loose clothing and confine long hair. Non-slip footwear or anti-skid floor strips are recommended. Do **not** wear gloves.
8. Wear ear protectors (plugs or muffs) during extended periods of operation.
9. Some dust created by power sanding, sawing, grinding, drilling and other construction activities contains chemicals known to cause cancer, birth defects or other reproductive harm. Some examples of these chemicals are:
 - Lead from lead based paint.
 - Crystalline silica from bricks, cement and other masonry products.
 - Arsenic and chromium from chemically treated lumber.

Your risk of exposure varies, depending on how often you do this type of work. To reduce your exposure to these chemicals, work in a well-ventilated area and work with approved safety equipment, such as face or dust masks that are specifically designed to filter out microscopic particles.
10. Do not operate this machine while tired or under the influence of drugs, alcohol or any medication.
11. Make certain the switch is in the **OFF** position before connecting the machine to the power supply.
12. Make certain the machine is properly grounded.
13. Make all machine adjustments or maintenance with the machine unplugged from the power source. A machine under repair should be RED TAGGED to show that it should not be used until maintenance is complete.
14. Remove adjusting keys and wrenches. Form a habit of checking to see that keys and adjusting wrenches are removed from the machine before turning it on.
15. Keep safety guards in place at all times when the machine is in use. If removed for maintenance purposes, use extreme caution and replace the guards immediately after maintenance is complete.
16. Check damaged parts. Before further use of the machine, a guard or other part that is damaged should be carefully checked to determine that it will operate properly and perform its intended function. Check for alignment of moving parts, binding of moving parts, breakage of parts, mounting and any other conditions that may affect its operation. A guard or other part that is damaged should be properly repaired or replaced.
17. Provide for adequate space surrounding work area and non-glare, overhead lighting.
18. Keep the floor around the machine clean and free of scrap material, oil and grease.
19. Keep visitors a safe distance from the work area. **Keep children away.**
20. Make your workshop child proof with padlocks, master switches or by removing starter keys.
21. Give your work undivided attention. Looking around, carrying on a conversation and "horse-play" are careless acts that can result in serious injury.

Warnings

22. Maintain a balanced stance at all times so that you do not fall or lean against the cutterhead or other moving parts. Do not overreach or use excessive force to perform any machine operation.
23. Use the right tool at the correct speed and feed rate. Do not force a tool or attachment to do a job for which it was not designed. The right tool will do the job better and more safely.
24. Use recommended accessories; improper accessories may be hazardous.
25. Maintain tools with care. Keep knives and knife inserts sharp and clean for the best and safest performance. Follow instructions for lubricating and changing accessories.
26. Remove loose items and unnecessary work pieces from the area before starting the machine.
27. Turn off the machine and disconnect from power before cleaning. Use a brush or compressed air to remove chips or debris — do not use your hands.
28. Do not stand on the machine. Serious injury could occur if the machine tips over.
29. Never leave the machine running unattended. Turn the power off and do not leave the machine until it comes to a complete stop.
30. When working a piece of wood on the jointer, follow the 3-inch radius rule: The hands must never be closer than 3 inches to the cutterhead.
31. Always use a hold-down or push block when surfacing stock less than 12 inches long, or 3 inches wide, or 3 inches thick.
32. Do not perform jointing operations on material shorter than 8 inches in length, narrower than 3/4 inches, or less than 1/4 inch thick.
33. Do not make cuts deeper than 1/8 inch to avoid overloading the machine and to minimize chance of kickback.
34. Never apply pressure to stock directly over the cutterhead. This may result in the stock tipping into the cutterhead along with the operator's fingers. Position hands away from extreme ends of stock, and push through with a smooth, even motion. Never back workpiece toward the infeed table.
35. "Pull-out" and the danger of kicked back stock can occur when the workpiece has knots, holes or foreign materials such as nails. It can also occur when the stock is fed against the grain. The grain should run in the same direction you are cutting. Before attempting to joint or plane, each workpiece must be carefully examined for stock condition and grain orientation.

NOTE: At certain times it may be necessary to plane against the grain when working with a swirl grain wood or burl. With this type of work the operator must use a lesser depth of cut and a slow rate of feed.
36. Do not use jointer in a dangerous environment, do not use in damp or wet locations, or expose the machine to rain. Keep work area well lighted.
37. Maintain the proper relationships of infeed and outfeed table surfaces and cutterhead knife path.
38. Support the workpiece adequately at all times during operation; maintain control of work at all times.
39. Do not back the workpiece toward the infeed table.
40. Always keep cutterhead and drive guards in place and in proper operation.

Familiarize yourself with the following safety notices used in this manual:

CAUTION This means that if precautions are not heeded, it may result in minor injury and/or possible machine damage.

WARNING This means that if precautions are not heeded, it may result in serious or possibly even fatal injury.

Introduction

This manual is provided by Powermatic covering the safe operation and maintenance procedures for a Powermatic Model 60C or 60HH Jointer. This manual contains instructions on installation, safety precautions, general operating procedures, maintenance instructions and parts breakdown. This machine has been designed and constructed to provide years of trouble free operation if used in accordance with instructions set forth in this manual. If there are any questions or comments, please contact either your local supplier or Powermatic. Powermatic can also be reached at our web site: www.powermatic.com.

Specifications

Model Number.....	60C	60HH
Stock Numbers:		
2HP 1PH 230V	1610084K.....	1610086K
3HP 3PH 230/460V (prewired 230V)*	1610085K.....	1610087K
Maximum depth of cut (in.)	1/2.....	1/2
Maximum rabbeting cut (in.).....	1/2.....	1/2
Cutterhead style	straight with 3 knives.....	helical w/ 54 four-sided inserts
Knife size (LxWxT)(in.)	8 x 11/16 x 1/8.....	0.59 x 0.59 x 0.10
Cutterhead speed (RPM).....	7000.....	7000
Knife cuts per minute.....	21,000.....	not applicable
Table size (LxH)(in.)	73 x 8-1/2.....	73 x 8-1/2
Infeed table length (in.)	35-1/4.....	35-1/4
Outfeed table length (in.)	35-1/2.....	35-1/2
Fence size (LxH)(in.)	38 x 4-3/4.....	38 x 4-3/4
Fence tilt (deg.)	45 and 90.....	45 and 90
Fence positive stops (deg.).....	45 forward, 90, 45 backward.....	45 forward, 90, 45 backward
Dust port diameter (in.)	4.....	4
Sound rating @ 20" (dB).....	93.....	92
Height, floor to outfeed table (in.).....	32.....	32
Footprint of cabinet (LxW)(in.).....	24 x 17.....	24 x 17
Overall size (LxWxH)(in.).....	73 x 25 x 46.....	73 x 25 x 46
Overall height of jointer without stand (in.)	13-1/2.....	13-12
Weights:		
Jointer (Net/Shipping)(lbs.)	295/363.....	297/366
Stand, 1PH (Net/Shipping)(lbs.)	114/119.....	114/119
Stand, 3PH (Net/Shipping)(lbs.)	118/123.....	118/123

***NOTE:** For 460V operation, magnetic switch (part no.PJ882-526C) must be purchased separately and installed. A qualified electrician is recommended.

The above specifications were current at the time this manual was published, but because of our policy of continuous improvement, Powermatic reserves the right to change specifications at any time and without prior notice, without incurring obligations.



Read and understand the entire contents of this manual before attempting set-up or operation! Failure to comply may cause serious injury.

Features and Terminology - 60C and 60HH Jointers

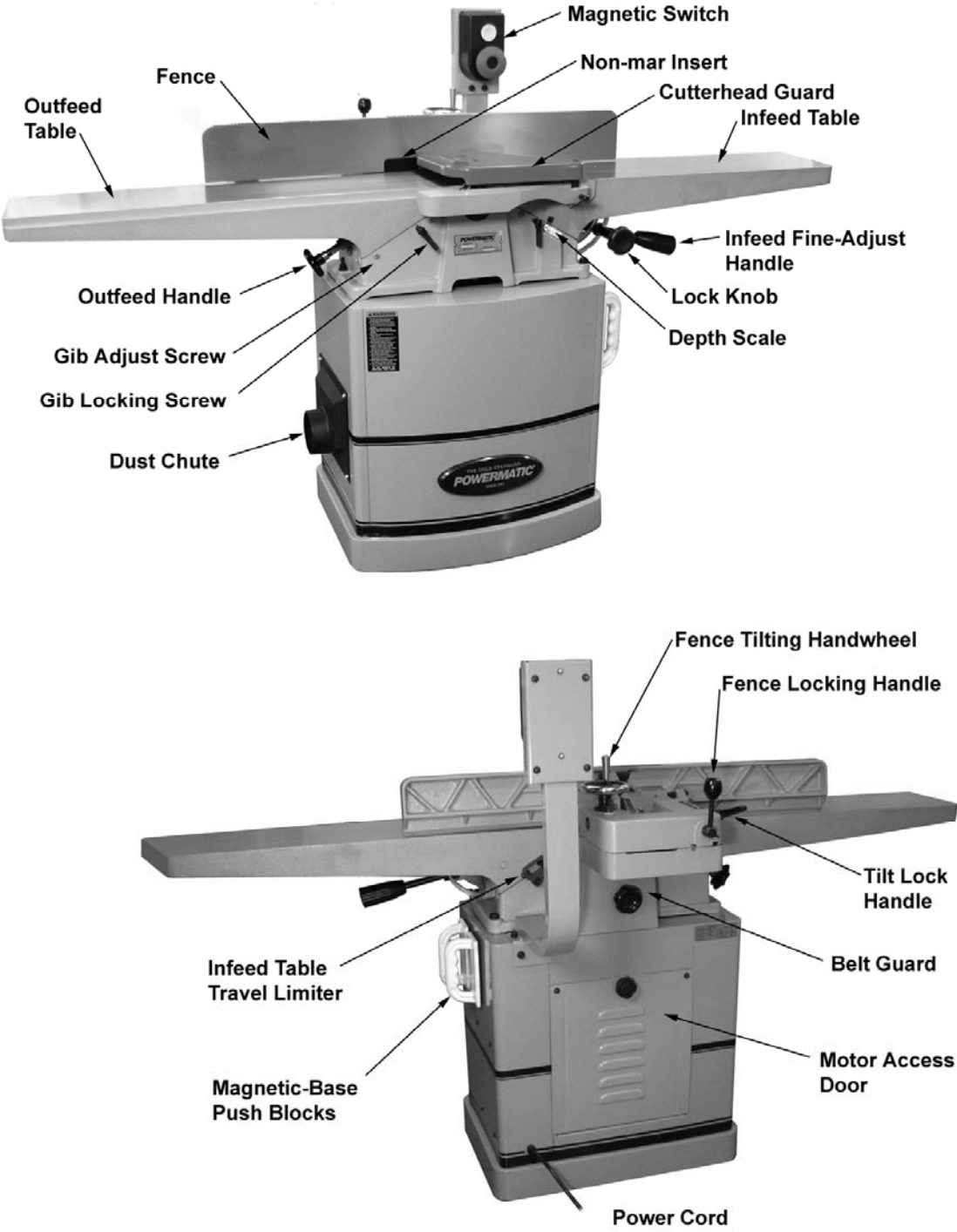

Figure 1

Unpacking

Open shipping cartons and check for shipping damage. Report any damage immediately to your distributor and shipping agent. Do not discard any shipping material until the Jointer is assembled and running properly.

Compare the contents of your cartons with the following parts list to make sure all parts are intact. Missing parts, if any, should be reported to your distributor. Read the instruction manual thoroughly for assembly, maintenance and safety instructions.

Contents of the Shipping Container

The following are included with both straight and helical cutterhead models (see Figures 2, 3, 4):

- 1 Jointer Assembly (A)
- 1 Stand Assembly (B)
- 1 Switch Arm (C)
- 1 Dust Chute (D)
- 1 Drive Belt (E)
- 1 Door (F)
- 2 Push Blocks (G)
- 1 Handwheel (H)
- 1 Cutterhead Guard (J)
- 2 Open End Wrenches, 12/14, 8/10mm (K)
- 1 Hex (Allen) Wrenches, 3mm, 4mm, 6mm (L)
- 1 Screwdriver (M)
- 1 Hardware Bag containing:
 - 3 Carriage Bolts, 3/8"-16 x 2-3/8" (AA)
 - 6 Flat Washers, 3/8" (BB)
 - 3 Lock Washers, 3/8" (CC)
 - 3 Hex Nuts, 3/8" (DD)
 - 4 Socket Head Cap Screws, 5/16"-18x3/4" (EE)
 - 4 Flat Washers, 5/16" (FF)
 - 4 Lock Washers, 5/16" (GG)
 - 4 Pan Head Screws, 1/4"-20 x 1/2" (HH)
 - 4 Flat Washers, 1/4" (JJ)
 - 2 Pan Head Screws, M6 x 12 (KK)
 - 2 Flat Washers, M6 (LL)
- 1 Owner's Manual (not shown)
- 1 Warranty Card (not shown)

Included with straight cutterhead models (60C) only:

- 1 Knife Setting Gauge Assembly (N)

Included with helical cutterhead models (60HH) only (see Figure 5):

- 2 Star Point Screwdrivers (O)
- 5 Knife Inserts (P)
- 10 Knife Insert Screws (R)

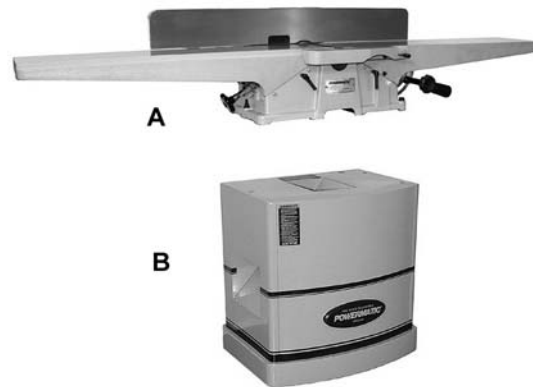

Figure 2

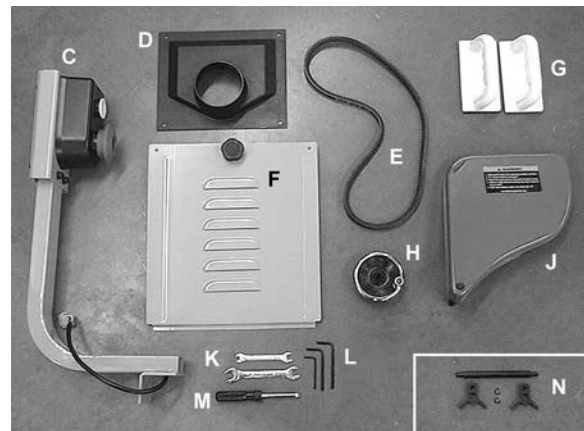

Figure 3

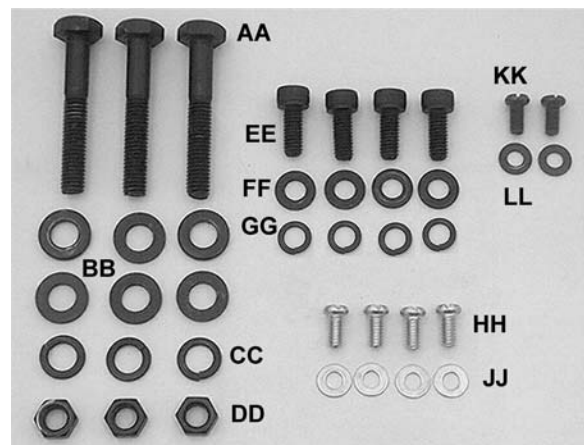

Figure 4

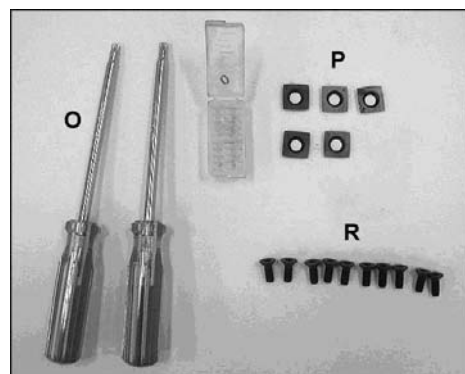

Figure 5 (helical cutterhead only)

Assembly

Exposed metal surfaces, such as the table and fence, have been given a protective coating at the factory. This coating should be removed with a soft cloth and solvent (such as mineral spirits) once the machine has been assembled. Do not use an abrasive pad as it may scratch the exposed surfaces.

NOTE: If any procedure described herein needs further clarification, consult the assembly drawings at the back of this manual.

Tools required for assembly:

3mm, 4mm and 6mm hex (Allen) wrenches
17mm, 14mm, (two)12mm open-end wrenches
screwdriver

Assembling Jointer to Stand

Refer to Figure 6.

1. Locate the *stand* on a level floor. If desired, the stand can be secured to the floor using two anchor bolts (not provided) through the holes inside the bottom of the stand. If using an optional mobile base, be sure to lock the wheels before assembling, operating or adjusting the jointer.

⚠WARNING The jointer is very heavy. Exercise proper caution when lifting it.

2. Use a hoist or forklift with straps, to lift the jointer onto the stand. (The front of the jointer should face the same direction as curved front of the stand.)
3. Shift the jointer atop the stand until the 3-hole pattern aligns in jointer base and stand.
4. Secure jointer base to stand with three 3/8"-16 x 2-3/8" carriage bolts (AA), six 3/8" flat washers (BB), three 3/8" lock washers (CC) and three 3/8" hex nuts (DD). (Note: On the left hand hole, it may be easier to insert the carriage bolt from beneath as shown.) Only finger tighten bolts until all three are properly inserted; then fully tighten the hex nuts with a 14mm wrench and a 17mm wrench on the heads of the screws.

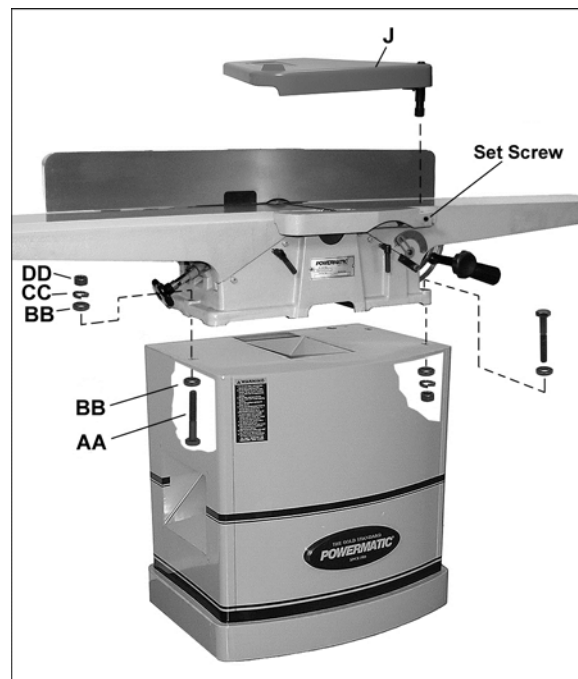

Figure 6

Cutterhead Guard

Place the post of the *cutterhead guard* (J, Figure 6) into the hole on the rabbeting ledge as shown. (**Always use caution when working near the cutterhead knives!**) Rotate the *set screw* with a 4mm hex wrench until it tightens into the groove on the cutterhead guard post.

The guard is spring tensioned. When mounted, it must have enough tension to completely cover the cutterhead, and press firmly against the fence. Test the tension by swinging the guard away from the fence and then releasing it. The guard should snap back to the fence.

NOTE: The guard must operate freely and must not drag on the rabbeting ledge or infeed table. If dragging occurs, check that the set screw (Figure 6) is tight. If guard still drags, the guard assembly may need adjustment or replacement.

Removing Guard:

Some adjustment procedures, and rabbeting operations, will require removal of the guard. Loosen set screw on rabbet ledge and vertically lift guard out of the hole.

Aligning Pulleys

Check that the motor pulley and cutterhead pulley are aligned; this will keep the belt vertical and help prevent excess wear on it. If adjustment is necessary, loosen the set screws in the motor pulley using a hex wrench, and slide the pulley as needed until alignment is achieved. Re-tighten set screws.

Installing Drive Belt

Refer to Figure 7.

1. Remove the belt guard (shown in Figure 9).
2. Place one end of the belt through the opening in the stand and into the groove of the cutterhead pulley.
3. Reach through the dust chute opening in the side of the stand with a 12mm wrench, and keep the motor mount screw heads stationary, while loosening the hex nuts with a second 12mm wrench from inside the stand (Figure 7).
4. Lift up on the motor to provide slack, and place the lower end of the drive belt into the motor pulley groove.
5. Let the motor slide back down and push down on it until the belt is properly tensioned. **NOTE:** There should be only moderate deflection, usually about $\frac{1}{2}$ " , in the belt midway between the pulleys when using light finger pressure (Figure 8).
6. Tighten the four hex nuts on the motor mount screws (Figure 7).

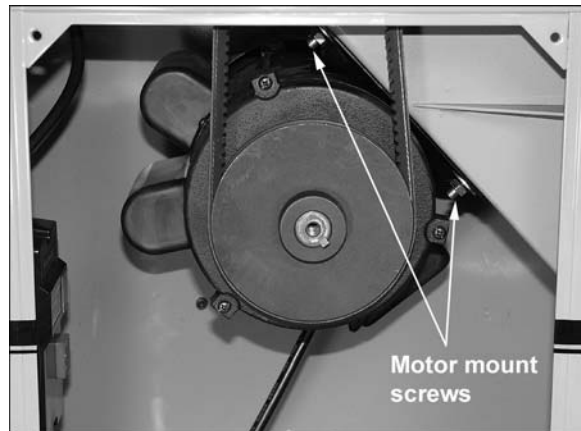

Figure 7

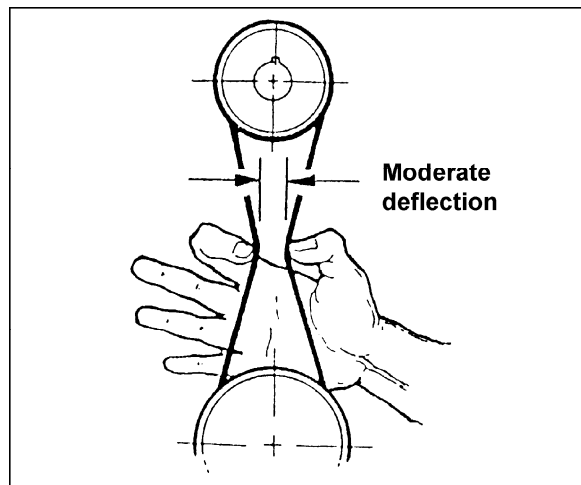

Figure 8

Installing Belt Guard and Door

Refer to Figure 9.

Mount the *belt guard* over the shaft as shown, and install the knob to secure it in place.

Set the lip of the *door* over the bottom edge of the stand opening. Rotate the door knob to hold the door to the stand.

NOTE: When the jointer is being operated, the two *M6 pan head screws (KK)* and *M6 flat washers (LL)* should be installed to fully secure the door. At this moment, however, leave these screws off until the switch has been installed.

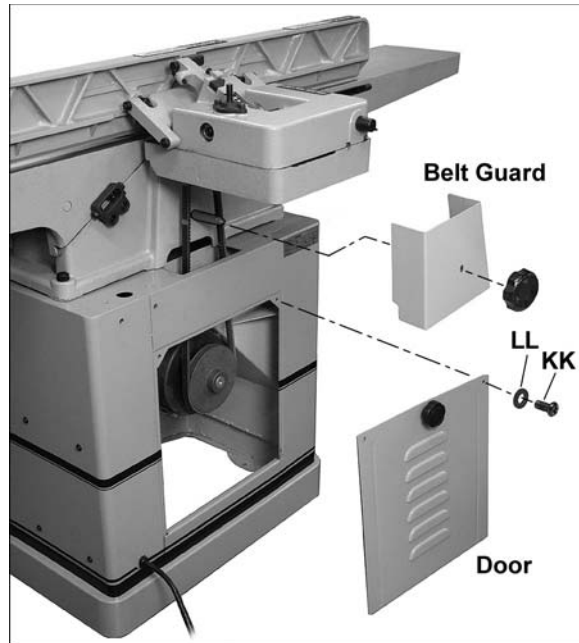

Figure 9

Installing Switch Arm

Refer to Figure 10.

1. Align the holes of the *switch arm* with the holes on the jointer stand, while slipping the electrical cord down through the larger hole in the stand.
2. Secure the switch arm with four *5/16"-18 x 3/4" socket head cap screws (EE)*, four *5/16" lock washers (GG)*, and four *5/16" flat washers (FF)*, using a 6mm hex wrench.
3. Open the stand door, and join the connectors of the switch cord and motor cord, as shown in the detail in Figure 10.

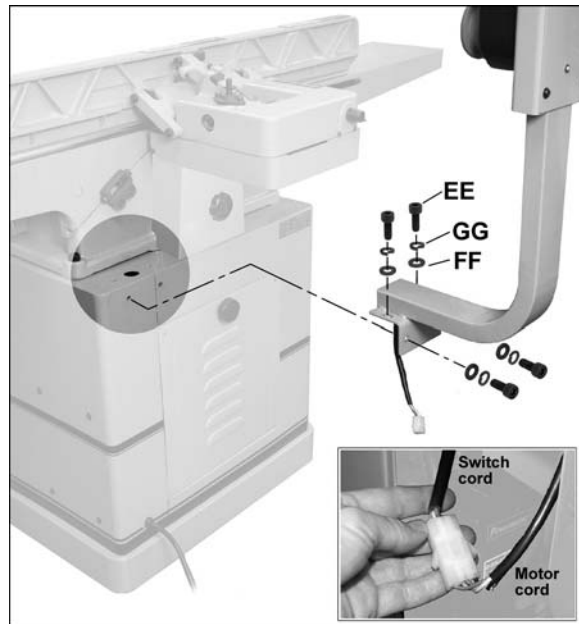

Figure 10

Installing Dust Chute

Refer to Figure 11.

It is strongly recommended that a dust collection system (not provided) be connected to the jointer. It will help keep your shop clean, and reduce the risk of health problems due to wood dust. The dust collector should have sufficient capacity for this size jointer. Visit our website at www.powermatic.com to see a range of available dust collection units.

Place the *dust chute* over the opening in the jointer stand, and secure with four *1/4"-20 x 1/2" pan head screws (HH)* and four *1/4" flat washers (JJ)*.

Connect a suitable dust collection hose to the dust chute on the jointer and secure it with a hose clamp. NOTE: *Dryer vent hose is not acceptable for this purpose.*

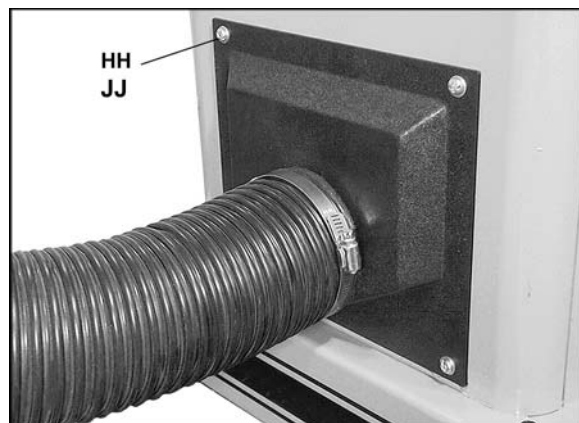

Figure 11
(hose and clamp not provided)

Installing Fence Handwheel

Refer to Figure 12.

Install the *handwheel* (H) onto the shaft, and tighten the set screw with a 3mm hex wrench.

Knife Gauge Assembly (model 60C only)

Refer to Figure 13.

The knife gauge assembly consists of a bar, two end pieces and two e-clips. Slide the end pieces onto the ends of the bar as shown, and use a pliers to push the e-clips into the grooves on the bar.

Storing the Push Blocks

The two provided push blocks have a magnetic base – you can attach them to the jointer stand or any metallic surface, to keep them within easy reach.

Electrical Connections

⚠WARNING Electrical connections must be made by a qualified electrician in compliance with all relevant codes. This machine must be properly grounded to help prevent electrical shock and possible fatal injury.

The Jointer is equipped with either a single phase, 230 volt motor; or a three phase, 230/460 volt motor.

The **single phase** unit is factory wired for 230 volts. The jointer has a ground plug that looks like the plug illustrated in Figure 14. Or, you may “hard-wire” the jointer directly to a service panel. It is recommended that the **single phase** jointer be connected to a dedicated, *minimum* 20 amp circuit with a 20 amp circuit breaker or time delay fuse. **Local codes take precedence over recommendations.**

The **three phase** motor is pre-wired for 230 volt. It may be re-connected for 460 volts by changing the connections as illustrated in the diagram in the starter box (see “Converting from 230 Volt to 460 Volt”). “Hard-wire” the machine directly to a control panel, and make sure a disconnect is available for the operator.

It is recommended that the **three phase** jointer, when operated at **230 volts**, be connected to a dedicated, *minimum* 20 amp circuit with a 20 amp circuit breaker or time delay fuse. When operated at **460 volts**, connect the jointer to a dedicated, *minimum* 15 amp circuit with 15 amp circuit breaker or time delay fuse. **Local codes take precedence over recommendations.**

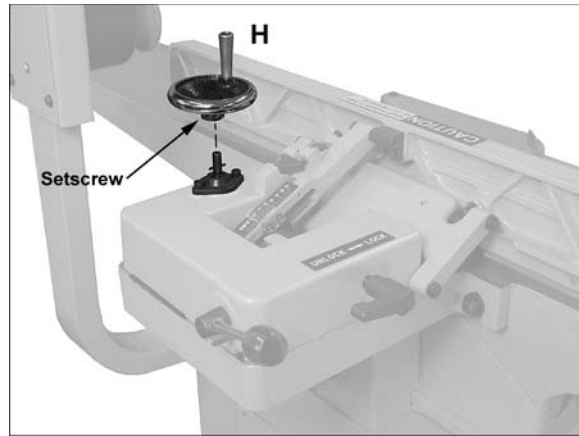

Figure 12

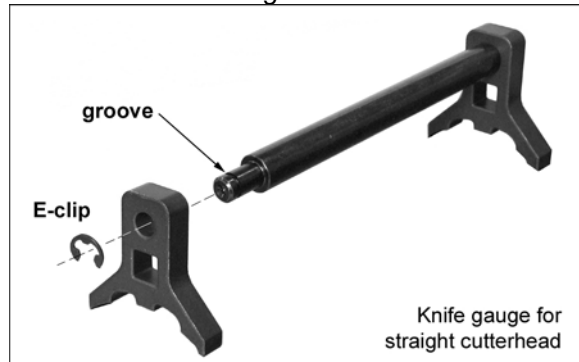

Figure 13
(model 60C only)

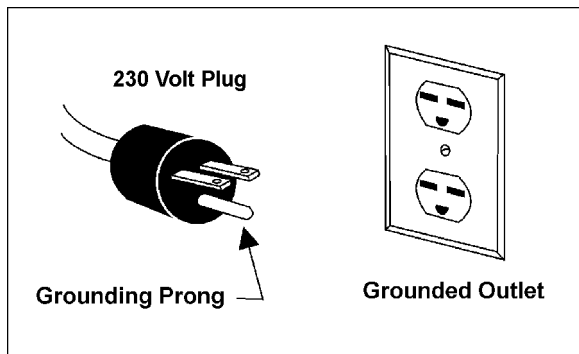

Figure 14

If the jointer is to be hard-wired to a panel, make sure a disconnect is available for the operator. During hard-wiring of the machine, make sure the fuses have been removed or the breakers have been tripped in the circuit to which the jointer will be connected. Place a warning placard on the fuse holder or circuit breaker to prevent it being turned on while the machine is being wired.

Grounding Instructions

This machine should be connected to a grounded metal permanent wiring system; or to a system having an equipment – grounding conductor. In the event of a malfunction or breakdown, grounding provides a path of least resistance for electric current to reduce the risk of electric shock.

Improper connection of the equipment-grounding conductor can result in a risk of electric shock. The conductor with insulation having an outer surface that is green with or without yellow stripes, is the equipment-grounding conductor. If repair or replacement of the electric cord or plug is necessary, do not connect the equipment-grounding conductor to a live terminal.

Check with a qualified electrician or service personnel if the grounding instructions are not completely understood, or if in doubt as to whether the tool is properly grounded. Repair or replace a damaged or worn cord immediately.

IMPORTANT: Make sure the electrical characteristics listed on the motor nameplate match those of the power source, and make sure the circuit on which the jointer will be used is properly fused and that wire size is correct.

Converting from 230 Volt to 460 Volt (Three Phase Only)

Consult the wiring diagram inside the starter box cover. A similar diagram is also included at the back of this manual. The Jointer must comply with all local and national codes after being wired.

1. Replace the current contactor with the 460V magnetic contactor (part no. PJ882-526C; purchased separately).
2. Re-connect the incoming leads to the motor in accordance with 460 volt operation, as shown in the wiring diagram.
3. If using a plug, install a proper UL/CSA listed plug suitable for 460 volt operation.

Three-Phase Test Run

On the **three-phase** unit, after wiring has been completed, you should check that the incoming leads have been connected properly:

1. Connect machine to power source and press the start button. *Make sure cutterhead is clear of all obstructions!* (See page 21 for more detailed instructions on the switch.)
2. The cutterhead should rotate clockwise as viewed from the front of the machine. If the cutterhead rotation is incorrect, press the stop button and **disconnect machine from power**.
3. Switch any two of the three leads to the motor, then re-connect to power.

Extension Cords

Make sure your extension cord is in good condition. Always use a cord that is heavy enough to carry the current your product will draw; the cord rating must be suitable for the amperage listed on the machine's motor plate. An undersized cord will cause a drop in line voltage resulting in loss of power and overheating.

Use the chart in Figure 15 as a general guide in choosing the correct size cord. If in doubt, use the next heavier gauge. The smaller the gauge number, the heavier the cord.

Recommended Gauges (AWG) of Extension Cords

Amps	Extension Cord Length *					
	25 feet	50 feet	75 feet	100 feet	150 feet	200 feet
< 5	16	16	16	14	12	12
5 to 8	16	16	14	12	10	NR
8 to 12	14	14	12	10	NR	NR
12 to 15	12	12	10	10	NR	NR
15 to 20	10	10	10	NR	NR	NR
21 to 30	10	NR	NR	NR	NR	NR

*based on limiting the line voltage drop to 5V at 150% of the rated amperes.

NR: Not Recommended.

Figure 15

Adjustments

⚠WARNING Disconnect machine from power source before making adjustments.

Tools required for adjustments:

- 8mm & 12mm wrenches
- 4mm hex wrench
- machinist's protractor or adjustable square
- steel straight edge

Installing and Adjusting Knives (Straight Cutterhead only)

Refer to Figure 16.

⚠CAUTION Use care when working with or around sharp knives. Make sure power to the machine has been disconnected.

When installing new knives, remove only one knife at a time. Clean the knife slot and install the new knife. Adjust and snug new knife in cutterhead before proceeding to next knife.

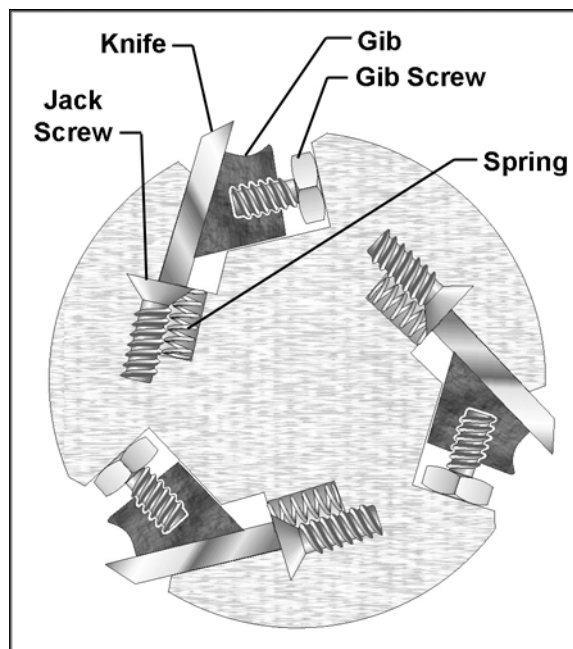
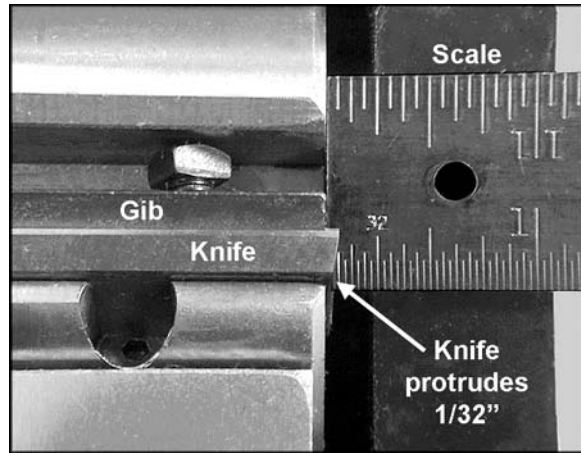

Figure 16
(straight cutterhead only)

1. Disconnect machine from power source.
2. Remove the belt guard so that you can rotate the cutterhead by turning the motor pulley or by moving the drive belt. **Do not** grab the cutterhead itself to rotate it.
3. Remove the old knives by loosening gib screws with an 8mm wrench, and allowing the springs to push the knife upward. Remove knife and gib.
4. Clean the gib and the knife slot. Sandwich new knife and gib together and drop into slot. Make sure the knife is oriented properly as shown in Figure 16.



*Figure 17
(straight cutterhead only)*

IMPORTANT: To position the knives for rabbet cuts, take a shop scale with 1/32" graduations and place it against the end of the cutterhead. See Figure 17. Slide the knife out until it is at the 1/32" mark on the scale; that is, the knife will now be 1/32" beyond the edge of the cutterhead. The gib should remain in normal position, even with the edge of the cutterhead. This adjustment will ensure that the knife clears the end of the gib and cutterhead, and has good contact with the workpiece. (See under "Basic Jointer Operation" for further information on rabbeting procedures.)

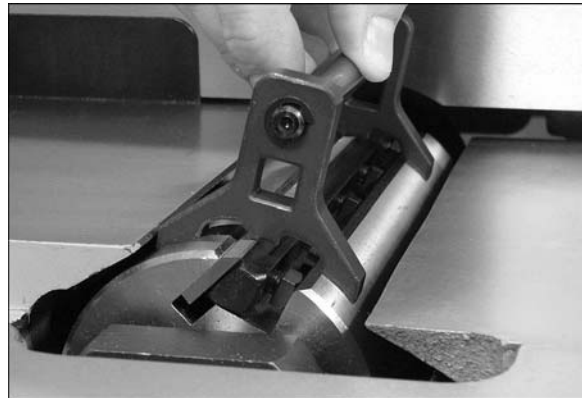

*Figure 18
(straight cutterhead only)*

5. The height of the knife in the slot, both for rabbeting and normal jointer work, must now be set properly, to ensure correct operation as well as minimize the hazard of kickback. Proceed as follows:
 6. Rotate the cutterhead (using the belt or pulley) until the tip of the knife is at the top of the cutterhead arc. Place the knife setting gauge (Figure 18) over the cutterhead so the tip of the knife contacts the center of the gauge, and all four "feet" of the gauge rest firmly upon the cutterhead, as the knife is pushed down into its slot. The gauge will position the knives at approximately .015" above the cutterhead. Knife height should not vary more than .002-.003" across the length of the cutterhead.
 7. Tightening the gib screws should be done in increments, to prevent any distortion to the cutterhead or buckling of knives. While holding the gauge down on one knife, snug down the five gib screws, beginning with the center screw and working your way to the ends. Do not fully tighten yet.
 8. Rotate the cutterhead to the next slot and repeat steps #6 and #7, only making the knives snug.
 9. Repeat for the third knife.

10. The tightening process should continue at least two more times, each time tightening the screws more on all three knives. On the third time, they should all be firmly tightened.

▲WARNING Before starting the jointer, make sure all gib screws are firmly tightened. A loose knife thrown from the cutterhead can cause severe or fatal injury.

11. After replacing knives, the outfeed table must be checked and adjusted so that it is level with the high point of the knives. See “Setting Outfeed Table” on pages 18-19.

Replacing and Rotating Knife Inserts (Helical Cutterhead Only)

▲WARNING Knife inserts are extremely sharp; use caution when working with or around them. Disconnect power.

The knife inserts on the model PJ-882HH are four-sided. When dull, simply remove each insert, rotate it 90° for a fresh edge, and re-install it.

Two star-point screwdrivers are provided. Insert one screwdriver into a screw to hold the cutterhead stationary, while using the other to loosen and remove a knife insert screw. See Figure 19. It is advisable to rotate all inserts at the same time to maintain consistent cutting. However, if one or more knife inserts develops a nick, rotate only those inserts that are affected.

Each knife insert has an etched reference mark so that you can keep track of rotations.

IMPORTANT: When removing or rotating inserts, clean saw dust from the screw, the insert, and the cutterhead platform. Dust accumulation between these elements can prevent the insert from seating properly, and may affect the quality of the cut.

Before installing each screw, lightly coat the screw threads with machine oil and wipe off any excess.

Securely tighten each screw which holds the knife inserts before operating the planer!

▲WARNING Make sure all knife insert screws are tightened securely. Loose inserts may be propelled at high speed from a rotating cutterhead, causing injury.

Make sure the outfeed table is set level with the knife inserts See “Setting Outfeed Table” on page 18-19.



Figure 19
(helical cutterhead only)

Leveling Tables

Refer to Figure 20.

The tables have been leveled with each other from the factory, but this should be confirmed by the user, and checked periodically, by placing a steel straight edge across both tables. If tables are not level, this may be the result of loose gibs. Correct as follows:

1. Loosen hex nuts on the gib screws (A) with a 12mm wrench, then loosen the gib screws with a 4mm hex wrench. Loosen the table lock handle (B).
2. Remove the lower hex nut and gib screw (A) and check screw hole to make sure that punch mark in the gib is aligned with the screw hole. If punch mark is not visible, or it does not line up with screw hole, use a screwdriver to lightly tap the gib back into alignment.
3. Re-install the lower gib screw (A) but do not tighten.
4. Carefully tighten the table lock screw (B). The table will begin to move toward the straight edge.
5. When aligned, re-set the gib screws (A) until tight. If table does not align with straight edge, use the adjusting arm (C) for the infeed table, or handwheel (D) for the outfeed table, until the table is flush with the straight edge.
6. Tighten the gib screws (A) then back them off approximately 1/4 turn or until the table moves freely, and re-set the lock nuts on the gib screws.

If table will still not line up:

Remove gib screws (A, Figure 20) and table locking handle (B) and remove gib. Check gib to see that set screws do not go all the way through the gib or dimple the opposite side. If either of these conditions exist, replace with a new gib.

Also, check to be sure the ways are clean and free of pitch and sawdust. Lubricate gib and way with a good grade of non-hardening grease.

Re-install the gib, making certain that the punch mark lines up with the locking screw holes. Re-install gib screws. Repeat steps 3 through 6 above.

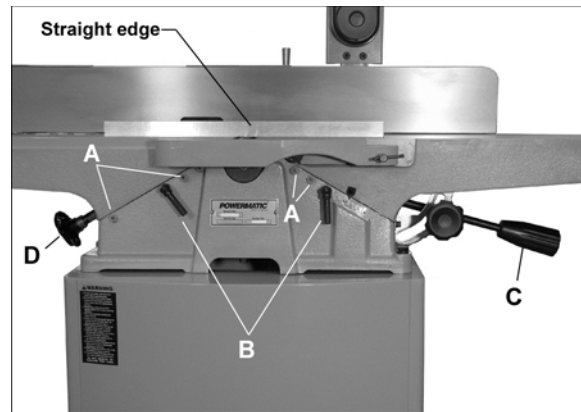

Figure 20

Adjusting Depth of Cut

Refer to Figure 21.

Depth of cut is determined by the height of the infeed table relative to the cutterhead. Setting the infeed table is achieved with both a rapid adjust and a fine adjust.

Rapid Adjust:

1. Loosen the lock screw (A) and the locking handle (B).
2. Raise or lower the height adjustment handle (C) until the scale (D) reads just under the correct depth of cut.

Fine Adjust:

3. Rotate the locking handle (B) until it is snug, then fine-tune the adjustment by rotating the height adjustment handle (C) until the scale reads exact. (Clockwise raises the table, counter-clockwise lowers the table.) A full rotation of the fine adjustment handle equals 1/16" travel of the infeed table.
4. When set, re-tighten lock screw (A).

Periodically check the accuracy of the depth of cut scale (D, Figure 21) by raising the infeed table until it is flush with the peak of the cutterhead arc (using a straight edge across table and cutterhead). The scale should read zero depth. If it does not, re-adjust the pointer above the scale.

Infeed Table Depth Stop

The infeed table depth stop (A, Figure 22) limits the cut to a maximum depth of 1/8". For normal operations, the depth of cut should never exceed 1/8".

1. Lower the infeed table to 1/8", which will cause the depth stop limiter to engage.
2. Pull out on the stop handle (B).
3. Continue lowering the table to the desired depth of cut.

Setting Outfeed Table

For accurate work in most jointing operations, the outfeed table must be exactly level with the knives at their highest point of revolution.

1. Raise the outfeed table to its highest point, and place a straight edge across it.
2. Rotate the cutterhead (using the belt or pulley) until one knife is at its highest point.
3. Loosen the locking handle on the outfeed table, and rotate the handwheel to lower the outfeed table until the straight edge contacts a knife. Rock the cutterhead slightly to make sure the apex of the knife is contacting the straight edge. Lock the outfeed table at that setting.

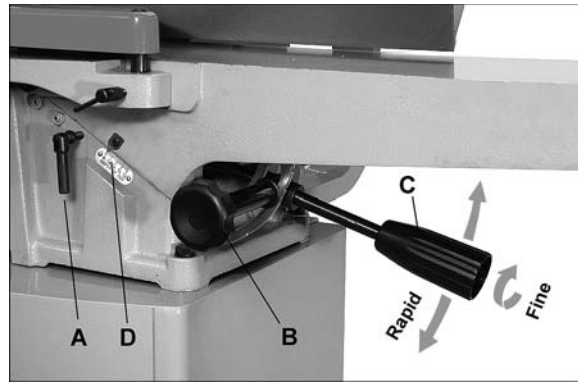

Figure 21

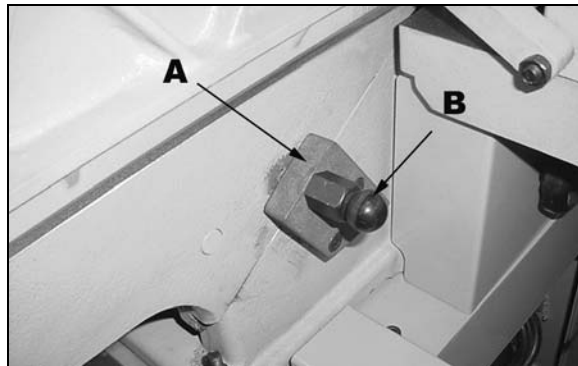

Figure 22

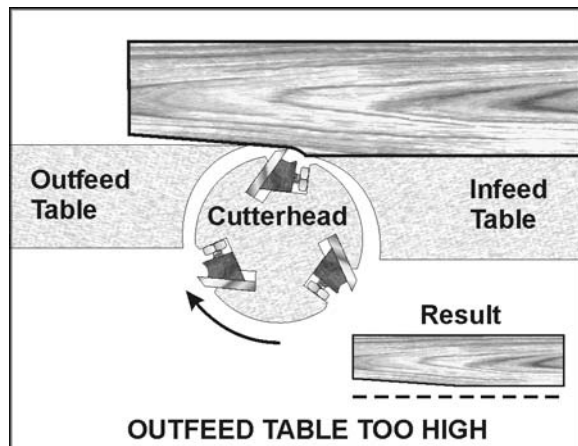

Figure 23

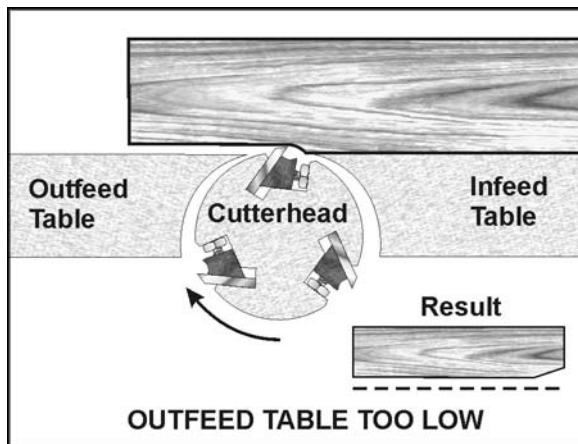

Figure 24

After the outfeed table has been set at the correct height, it should not be changed except for special operations or after replacing knives.

Examples of incorrect settings:

If the outfeed table is too high, the finished surface of the workpiece will be tapered (Figure 23).

If the outfeed table is too low, the work will be gouged at the end of the cut (Figure 24)

As a final check of the outfeed table adjustment, run a piece of wood slowly over the knives for 6 to 8 inches; it should rest firmly on both tables (Figure 25) with no open space under the finished cut.

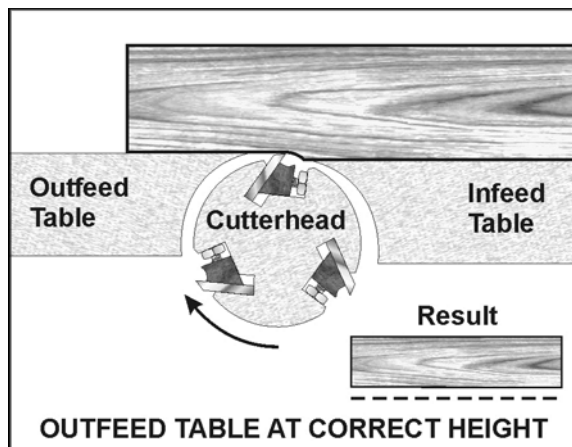

Figure 25

Spring Cutting

Refer to Figure 26.

To spring cut, the outfeed table is lowered below the level of the cutterhead, as shown in Figure 26. Loosen both gib screws (A) on the outfeed table. Amount of end-drop is controlled with the table lock screw (B). Tighten handle to reduce amount of drop. A 1/32" drop usually creates the ideal concave for spring joints. After completing a spring cut, return the outfeed table in line with the cutterhead knives.

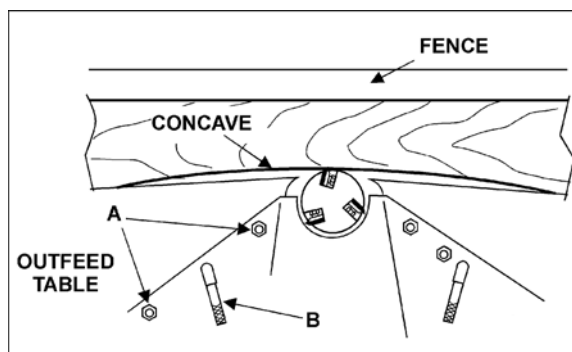

Figure 26

Fence Movement

Refer to Figure 27.

To slide the fence forward or backward on the table, loosen lock handle (A), slide the fence to desired position and tighten lock handle (A) to secure fence. **Lift up on fence when tilting or sliding, to prevent scratching the table.**

NOTE: The lock handle (A, Figure 27) may be adjusted to a more convenient position by loosening the hex nut below the casting (B, Figure 28), turning the handle to the proper position, and retightening the hex nut.

To tilt the fence **forward**:

1. Loosen locking handle (C, Figure 27).
2. Place an angle measuring device on the table and against the fence. Tilt the fence to desired angle using the handwheel, and tighten locking handle (C) to secure the setting.

To tilt the fence **back**:

1. Loosen locking handle (C, Figure 27).
2. Flip the stop block (D) out of the way.
3. Tilt the fence to desired angle using the handwheel, and tighten locking handle (B) to secure the setting.

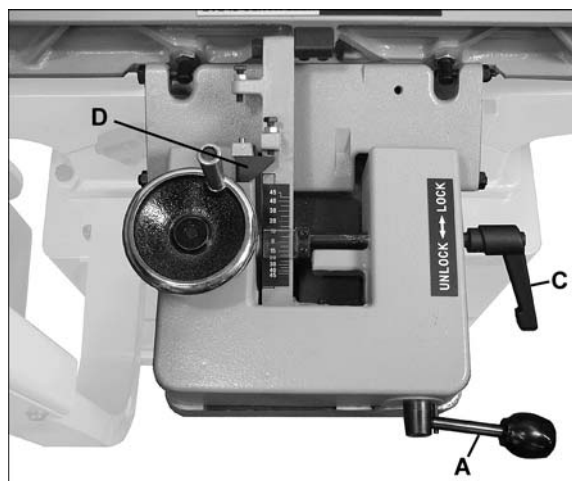

Figure 27

CAUTION When the tilted operation is finished and the fence is returned to 90 degrees, don't forget to flip the stop block back to its original position.

Fence Stops

See Figure 29.

Periodically check the 90 degree and 45 degree tilt accuracy of the fence with an angle measuring device, such as an adjustable square or machinist's protractor. If adjustments are necessary, proceed as follows:

90-degree stop:

1. The 90-degree stop is controlled by the screw (E, Figure 29).
2. Loosen the locking handle (C) and the hex nut on the screw (F).
3. Set a square on the table and against the fence, and rotate the handwheel (G) to move the fence flush against the square. Rotate the screw (E) until it contacts the stop block (D).
4. Tighten the hex nut (F) and the locking handle (C).

45 degree forward stop:

1. The 45 degree forward stop is controlled by a screw (H, Figure 29) that is located at the bottom end of the link bar.
2. Loosen the locking handle (C) and the hex nut on the screw (H).
3. Set a 45 degree measuring device on the table and against the fence, and tilt the fence until it is flush against the device, and therefore at a 45 degree angle.
4. Rotate the screw (H) until it contacts the casting below it.
5. Tighten hex nut (H) and locking handle (C).

45 degree back stop:

1. Flip the stop block (D, Figure 29) out of the way.
2. The 45 degree back stop is controlled by the screw (J).
3. Loosen the locking handle (C) and the hex nut on the screw (K).
4. Use an angle measuring device set at 45 degrees beyond the right angle (a total of 135 degrees) and place it on the table and against the fence. Tilt the fence until it is flush with the protractor.
5. Rotate the screw (J) to the proper height.
6. Tighten hex nut (K) and locking handle (C).

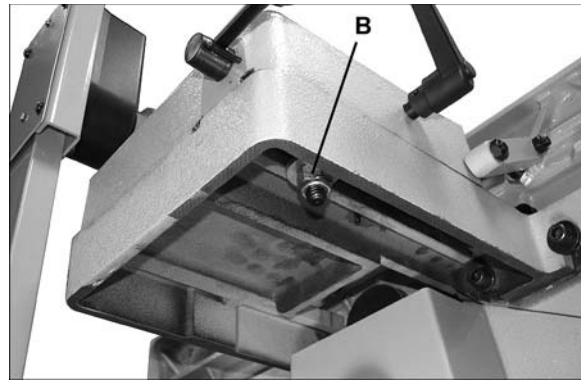

Figure 28

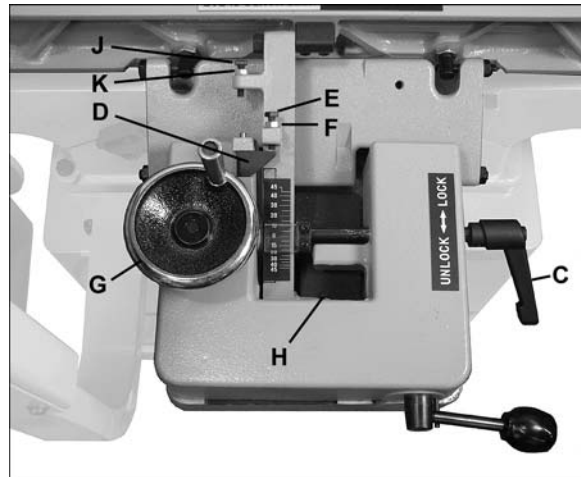

Figure 29

Operating Controls

Start/Stop

Power Indicator Light – The *start switch* has a power indicator lamp which is *on whenever there is power connected* to the Jointer, not just when the Jointer is running. *Do not assume that no light means there is no power to the machine.* If the bulb is bad, there will be no indication. Always check before use.

⚠WARNING Do not rely that no light means no power to the machine. Always check for power first. Failure to comply may cause serious injury!

Refer to Figure 30:

Start – Press the green start switch.

When power is connected to the machine, the green light is always on regardless of whether the Jointer is running or not.

Stop – Press the red switch to stop.

Reset – In the event that the Jointer stops without pressing the stop button, as the result of a tripped fuse or circuit breaker, etc.:

Press red button to reset main switch.

Press the green button to restart the machine.

Safety Key

The start/stop switch on the Jointer comes equipped with a magnetic safety key. When in place on the switch as shown in Figure 30, the magnetic safety key trips a relay which will allow the machine to start and stop when the respective switches are pressed. Being magnetic, the lock can be removed to make the machine inoperable and can be hidden for safe storage by attaching it to another magnetic surface.

When using the Jointer, place the key on the switch cover lining up the arrow on the key with the REMOVE arrow on the cover. Then rotate the key so that the arrow lines up with the LOCK arrow on the cover. This will prevent the safety key from coming loose from vibration when the machine is in use.

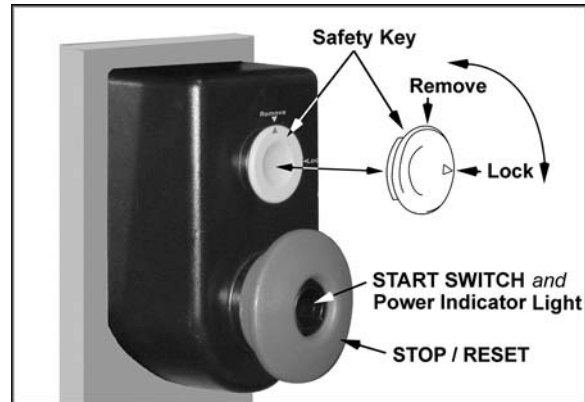

Figure 30

Basic Jointer Operation

NOTE: If you are inexperienced at jointing, use scrap pieces of lumber to check settings and get the feel of operations before attempting regular work.

This section briefly discusses general rules as well as some of the basic cuts using a jointer, such as surfacing, edging, beveling, skewing, rabbeting and taper cuts.

⚠ WARNING Always use cutterhead guard (except during rabbeting) and keep hands away from cutterhead.

Jointing Short or Thin Work

When jointing short or thin pieces, use a push pad or push block to eliminate all danger to the hands. Two push blocks are included with your jointer. Many users make their own push blocks from scrap material to suit the particular job at hand. Three examples are shown in Figure 31.

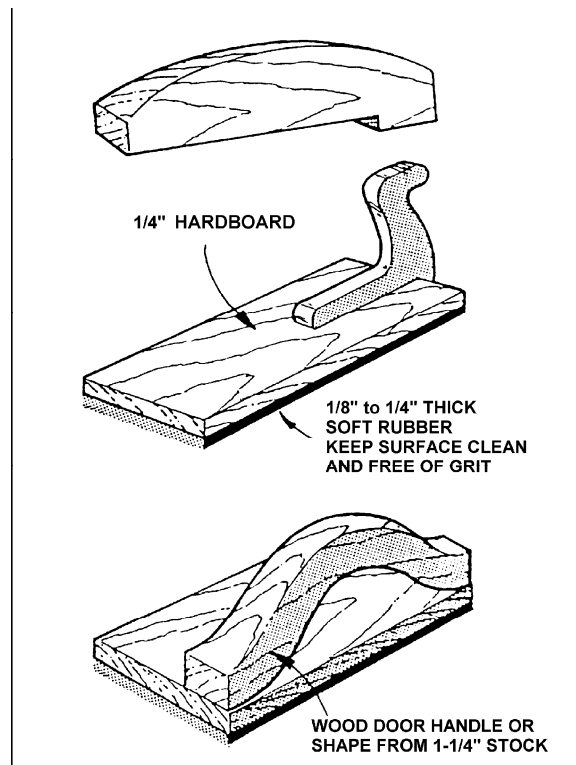

Figure 31
User-made pushblocks

Direction of Grain

Avoid feeding work into the jointer against the grain. This will result in chipped and splintered edges (Figure 32). Feed with the grain to obtain a smooth surface (Figure 33).

Hand Placement

At the start of the cut, the left hand holds the work firmly against the infeed table and fence while the right hand pushes the work toward the knives. After the cut is under way, the new surface rests firmly on the outfeed table. The left hand should press down on this part, at the same time maintaining flat contact with the fence. The right hand presses the work forward and before the right hand reaches the cutterhead it is moved to the work on the outfeed table. **Follow the 3 inch rule. Never pass hands directly over the cutterhead.**

Surfacing

Jointing the face of stock, or surfacing, is shown in Figure 34. The use of push blocks or pads will help ensure against the operator's hands coming into contact with the cutterhead in the event of a kickback, or as the trailing end of the board passes over the cutterhead.

Adjust the infeed table for depth of cut. Cuts of approximately 1/16" at a time are recommended, as this allows better control over the material being surfaced. More passes can then be made to reach the desired depth.

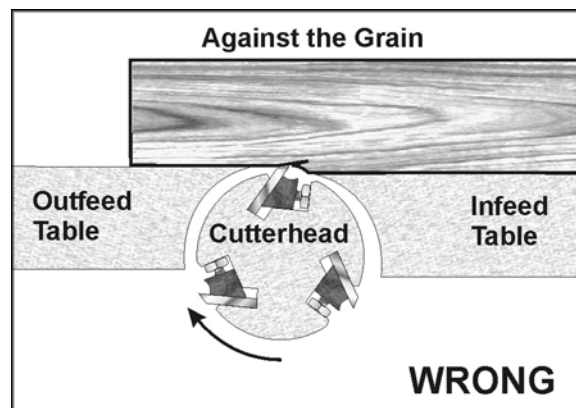

Figure 32

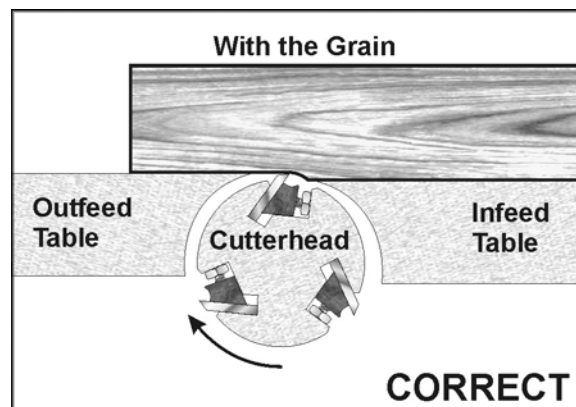

Figure 33

IMPORTANT: When stock is longer than twice the length of the infeed and outfeed tables, an assistant or support table must be used to support the stock.

WARNING Always use a hold down or push block when surfacing short stock or stock less than 3 inches thick.

Jointing Warped Surfaces

If the wood to be jointed is dished or warped, take light cuts until the surface is flat. Avoid forcing such material down against the table; excessive pressure will spring it while passing the knives, and it will simply spring back and remain curved after the cut is completed.

Edge Jointing

This is the most common operation for the jointer. Set guide fence square with the table. Depth of cut should be the minimum required to obtain a straight edge. Do not make cuts deeper than 1/8" in a single pass. Hold the best face of the piece firmly against the fence throughout the feed. See Figure 35.

When edging stock wider than 3 inches, lap the fingers over the top of the wood, extending them back over the fence so that the fence casting will act as a stop for the hands in the event of a kickback.

Beveling

Never make cuts deeper than 1/16 inch when beveling. Make certain material being beveled is over 12 inches long, more than 1/4" thick and 1" wide.

CAUTION Although the fence may be tilted in or out for a bevel cut, it is recommended for safety reasons that the fence be tilted in toward the operator, making a cradled cut.

Set fence to desired angle. For stock wider than 3", hold with the fingers close together near the top of the stock, lapping over the board and extending over the fence. When beveling material less than 3" wide, use beveled push blocks.



Figure 34



Figure 35

Skewing (Shear Cutting)

When edging or facing burl or birds-eye maple, it is not unusual to deface or mar the surface being finished. This is caused by the cutterhead knives occasionally cutting against the grain. In order to prevent the defacing or marring of this type wood, it is necessary to skew, or angle finish, the material being worked.

Refer to Figure 36.

1. Release the fence locking handle (A, Figure 36) and remove the hex nut and washer (B) holding the fence to the fence support. Remove the fence assembly.
2. Remove the key (C) and the 1/4"-20 x 1/4" socket head cap screw (D) from the fence support. (The socket head screw keeps the non-mar insert from hitting the key.)
3. Position the fence assembly at the desired angle across the cutterhead.
4. Secure the fence to the support with the hex nut and washer (B), then tighten the fence locking handle (A).

When resuming work with normal stock, always re-install the key and the socket head cap screw!

Taper Cuts

A useful jointer operation is cutting an edge to a taper. The method can be used on a wide variety of work. Tapered legs of furniture are a common example. Instead of laying the piece on the infeed table, lower the forward end of the work onto the outfeed table. **Do this very carefully**, as the piece will span the knives, and they will take a "bite" from the work with a tendency to kick back unless the piece is firmly held. Now push the work forward as in ordinary jointing.

The effect is to plane off all the stock in front of the knives to increasing depth, leaving a tapered surface. The ridge left by the knives when starting the taper may be removed by taking a very light cut according to the regular method for jointing, with the infeed table raised to its usual position.

Practice is required in taper operations, and the beginner is advised to make trial cuts on waste material. Taper cuts over part of the length and a number of other special operations can easily be done as the operator gains experience.

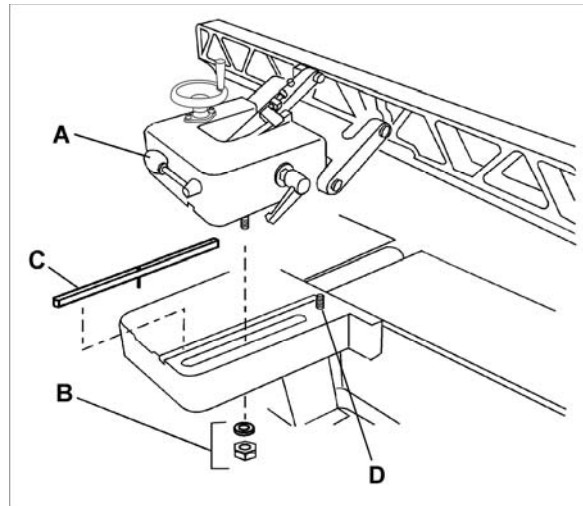

Figure 36

Rabbeting

⚠WARNING A rabbet cut requires removal of the cutter guard. Use extreme caution and keep hands clear of cutterhead. Always replace guard immediately after rabbeting operation is completed.

Refer to Figure 37.

A rabbet is a groove cut along the edge of a board. Never rabbet a piece of wood less than 12" long. Use push blocks to rabbet cut whenever possible.

1. Disconnect machine from power source.
2. Set fence for the desired width of the rabbet.
3. Check the width of the rabbet by measuring the distance from the end of a knife in the cutterhead to the fence. (See figure 17 to set knives for rabbeting.)
4. Lower infeed table 1/32" at a time and make successive cuts until the desired depth of rabbet has been obtained. NOTE: It is easier and safer to take a series of shallow cuts.

When *rabbeting* long pieces, follow the same procedure as for *surfacing* long pieces (refer to previous "Surfacing" section.)

Maintenance

⚠WARNING Disconnect machine from power source before doing any maintenance.

The table and fence surfaces must be kept clean and free of rust for best results. Some users prefer a light coat of paste wax. Another option is talcum powder applied with a blackboard eraser rubbed in vigorously once a week, which will fill casting pores and form a moisture barrier. Products in aerosol form are also available in major hardware stores and supply catalogs. Whatever method is chosen, the coating should protect the metal and provide a smooth surface, without staining the wood.

The fence assembly should slide easily over the fence support. Keep the fence support greased.

The bearings in the cutterhead are sealed and do not require lubrication.

Gum and pitch which collect on the knives cause excessive friction as the work continues, resulting in overheating of the knives, less efficient cutting, and consequent reduction in the life of the knives. Use an oven cleaner or gum and pitch remover to wipe such residue off the knives.



Figure 37

Sharpening Knives (*model 60C only*)

Knives should be kept sharp. This will contribute to better stock finish, longer machine life, and safer operation.

A jointer knife hone provides a simple way to sharpen straight knives. Hones are available from many woodworking supply stores. Carefully read any instructions that accompany the hone.

⚠WARNING Use caution and proceed slowly when sharpening knives. Disconnect jointer from power source, and wear approved eye protection.

When finished sharpening knives, they should be re-set level to the outfeed table. See the “*Installing and Adjusting Knives*” section in this manual.

Knives can usually be whetted several times in the cutterhead before having to be removed and re-ground.

TIP: If the jointer is used frequently, keeping a spare set of knives on hand is recommended. Extra knives (stock no. 6296046, set of 3) may be obtained from your Powermatic distributor, or by calling Powermatic at 1-800-274-6848.

Cutterhead Maintenance

The entire cutterhead assembly may be removed for bearing replacement or other maintenance procedures.

1. Disconnect jointer from power source.
2. Remove fence assembly from jointer (see Figure 36 and accompanying instructions).
3. Loosen motor mounting and push up on motor to create slack in belt (see page 10)
4. Remove drive belt from cutterhead pulley.
5. Lower both infeed and outfeed tables.
6. Loosen the two socket head cap screws on the fence support and pivot the fence support out of the way (see Figure 38).
7. Remove rabbeting ledge by loosening the two hex cap screws and washers (A, Figure 39).
8. Loosen the two bolts (B, Figure 39) that secure the cutterhead to the bed – these are accessed from the underside of the bearing blocks.

⚠CAUTION Either remove the knives or knife inserts from the cutterhead, or wrap cloths around it to prevent injury.

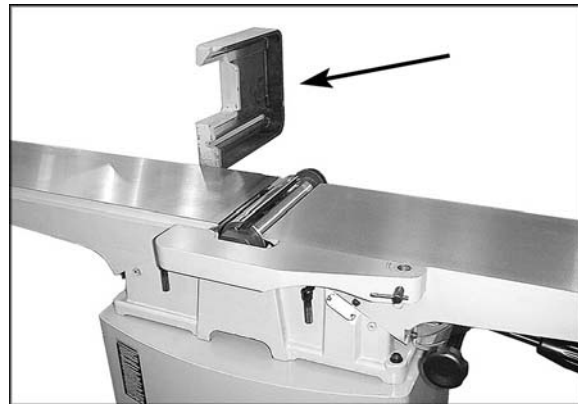

Figure 38

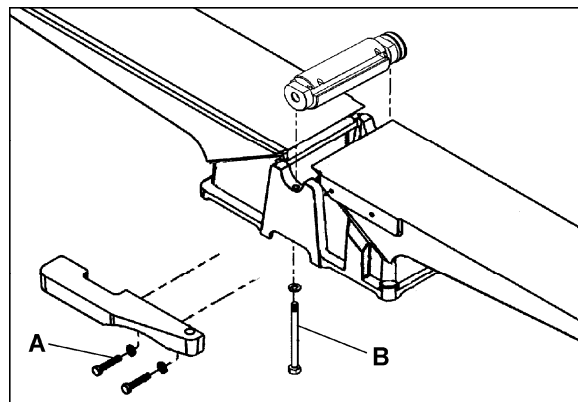

Figure 39

9. Lift cutterhead straight up from base.
10. Remove pulley and both bearing housings.

IMPORTANT: The bearings are press fitted; if they need replacement, this should be done by qualified service personnel only.

To re-install cutterhead, reverse the above procedure. Before re-installing, make sure the machine's curved seats of the base casting are free of dirt, dust or grease, to help ensure a tight fit.

NOTE: Whenever the cutterhead is re-installed on the jointer, the tables must be leveled in relationship to it. See the appropriate sections in this manual.

You may wish to keep an extra cutterhead on hand to maintain shop productivity.

Table Removal

Should the table(s) ever need to be removed, such as for gib maintenance or replacement, proceed as follows:

1. Disconnect jointer from power source.
2. Remove fence assembly except for the support casting.
3. Remove cutter guard.
4. Lower infeed and outfeed tables and remove cutterhead.
5. Loosen the gib set screws and table lock screws.

CAUTION After gib screws are loosened, table could suddenly slide down.

6. Remove infeed or outfeed table by sliding upward.

Troubleshooting – Mechanical and Electrical Problems

Trouble	Probable Cause	Remedy
Machine will not start/restart or repeatedly trips circuit breaker or blows fuses.	No incoming power.	Verify unit is connected to power, on-button is pushed in completely, and stop-button is disengaged.
	Overload automatic reset has not reset.	When jointer overloads on the circuit breaker built into the motor starter, it takes time for the machine to cool down before restart. Allow unit to adequately cool before attempting restart. If problem persists, check amp setting on the motor starter inside the electrical enclosure – it should match the amps on the motor as indicated on the motor plate.
	Jointer frequently trips.	One cause of overloading trips which are not electrical in nature is too deep of a cut. The solution is to take a lighter cut. If too deep a cut is not the problem, then check the amp setting on the overload relay. Match the full load amps on the motor as noted on the motor plate. If amp setting is correct then there is probably a loose electrical lead.
	Building circuit breaker trips or fuse blows.	Verify that jointer is on a circuit of correct size. If circuit size is correct, there is probably a loose electrical lead. Also check amp setting on motor starter.
	Switch or motor failure (how to distinguish).	Examine motor starter for burned or failed components. If damage is found, replace starter. If no visible damage found, have starter tested. If you have access to a voltmeter, you can separate a starter failure from a motor failure by first, verifying incoming voltage at 220+/-20 and second, checking the voltage between starter and motor at 220+/-20. If incoming voltage is incorrect, you have a power supply problem. If voltage between starter and motor is incorrect, you have a starter problem. If voltage between starter and motor is correct, you have a motor problem.
	Motor overheated.	Clean motor of dust or debris to allow proper air circulation. Allow motor to cool down before restarting.
	Motor failure.	If electric motor is suspect, have it tested by qualified service personnel. Repair or replace as needed.
	Electrical leads are attached incorrectly.	Double check to confirm all electrical connections are correct. Refer to appropriate wiring diagrams posted on the machine and at the back of this manual, to make any needed corrections.

Trouble	Probable Cause	Remedy
Machine will not start/restart or repeatedly trips circuit breaker or blows fuses.	Loose electrical connections.	Inspect all motor leads for tightness. Look for any signs of electrical arcing which would indicate loose connections or circuit overload.
	On/off switch failure.	If the on/off switch is suspect, you have two options: Have a qualified electrician test the switch for function, or purchase a new on/off switch and establish if that was the problem on changeout.

Troubleshooting – Operating Problems

Trouble	Probable Cause	Remedy
Finished stock is concave on back end.	Knife is higher than outfeed table.	Raise outfeed table until it aligns with tip of knife. See pages 18-19.
Finished stock is concave on front end.	Outfeed table is higher than knife.	Lower outfeed table until it aligns with tip of knife. See pages 18-19.
Stock has slight bevel after edge jointing.	Fence not perpendicular to table.	Square up fence with table.
Chip out.	Cutting against the grain.	Cut with the grain whenever possible.
	Dull knives/knife inserts.	Sharpen or replace knives. Rotate knife inserts.
	Feeding workpiece too fast.	Use slower rate of feed.
	Cutting too deeply.	Make shallower cuts.
	Knots, imperfections in wood.	Inspect wood closely for imperfections; use different stock if necessary.
Fuzzy, rough, or torn grain.	Wood has high moisture content.	Allow wood to dry or use different stock.
	Dull knives/knife inserts.	Sharpen or replace knives. Rotate knife inserts.
	Knives are cutting against grain.	Cut with the grain.
Board thickness does not match depth of cut scale.	Depth of cut scale is incorrect.	Loosen screw and adjust scale accordingly.
Cutterhead slows while operating.	Feeding too quickly, or applying too much pressure to workpiece.	Feed more slowly, or apply less pressure to workpiece.
	Excessive depth of cut.	Reduce depth of cut.
	Dull knives/knife inserts.	Sharpen or replace knives. Rotate knife inserts.
"Chatter" marks on workpiece.	Knives incorrectly set on straight cutterhead.	Set knives properly using provided knife setting gauge. Check that knife slots are clean and free of dust or debris.
	Feeding workpiece too fast.	Feed workpiece slowly and consistently.
Uneven knife marks on workpiece.	Knives are nicked, or out of alignment.	<i>Straight cutterhead:</i> Replace nicked knives; align knives properly using knife-setting gauge. See pages 14-16. <i>Helical cutterhead:</i> Rotate nicked inserts. See page 16.

Replacement Parts

Replacement parts are listed on the following pages. To order parts or reach our service department, call 1-800-274-6848, Monday through Friday (see our website for business hours, www.powermatic.com). Having the Model Number and Serial Number of your machine available when you call will allow us to serve you quickly and accurately.

Parts List: Base Assembly (60C and 60HH)

Index No.	Part No.	Description	Size	Qty
1	6296000	Rear Table		1
2	TS-0267041	Set Screw	1/4"-20x3/8"	6
3	6296001	Collar		1
4	6296002	Bracket		1
5	6296003	Key	5x5x12mm	1
6	6296004	Lead Screw		1
7	6296005	Bracket		1
8	TS-0720091	Lock Washer	3/8"	2
9	TS-0209061	Cap Screw	3/8"-16x1-1/4"	2
10	TS-0720111	Lock Washer	1/2"	2
11	6296009	Cap Screw	1/2"-12NCx1-1/2"	2
12	6296010	Bolt		2
13	TS-0561021	Hex Nut	5/16"-18	6
14	TS-0267091	Set Screw	1/4"-20x1"	6
15	60B-215	Base		1
16	6296013	Gib		2
17	TS-0208041	Socket Head Cap Screw	5/16"-18x3/4"	3
18	6296015	Retaining Ring	ETW-6	3
19	6296132	Bar		1
20	6296016	Bolt		1
21	6296017	Shaft		1
22	6296018	Lock Bracket		1
23	6296019	Bracket		1
24	6296020	Ball		2
25	6296021	Shaft		1
26	6296022	Retaining Ring	ETW-12	2
27	6296023	Worm		1
28	6296024	Key	5x5x20	1
29	6296025	Adjusting Base		1
30	TS-0680021	Flat Washer	1/4"	1
31	TS-0050031	Hex Cap Screw	1/4"-20x3/4"	1
32	6296029	Worm Shaft		1
33	6296028	Handle		1
34	TS-0680021	Flat Washer	1/4"	2
35	TS-0207021	Socket Head Cap Screw	1/4"-20x1/2"	6
36	TS-0720071	Lock Washer	1/4"	5
37	6296033	Clamp Knob		1
38	TS-0680061	Flat Washer	1/2"	1
39	6296035	Lock Plate		1
40	6296036	Plate		1
41	60B-241	Front Table		1
42	6296038	Handwheel		1
43	6296039	Phillips Pan Head Screw	5/16"-18x1/2"	1
44	TS-0680041	Flat Washer	3/8"	1
45	60B-245	Rabbeting Ledge		1
46	TS-0680041	Flat Washer		3
47	TS-0060051	Hex Cap Screw	3/8"-16x1"	2

Index No.	Part No.	Description	Size	Qty
48	6296044	Pointer		1
49	TS-081B012	Phillips Pan Head Screw	#8-32x1/4"	1
50	6296056	Bolt		1
51	6296057	Belt Guard		1
52	6296058	Knob		1
53	60C-253	Spring		1
54	60C-254	Set Block		1
55	60C-255	Limit Rod		1
56	6296063	Collar		1
57	TS-0680031	Flat Washer	5/16"	6
59	6296167	Depth Scale		1
60	VS020500	Rivet	2x5mm	4
61	TS-0267021	Socket Set Screw	1/4"-20x1/4"	4
62	6296151	Collar		2
63	60C-263	Push Block		2
64	TS-0208021	Socket Head Cap Screw	5/16"-18x1/2"	1
65	6296166	Flat Washer	5/16"x3/4"D	2
66	TS-0209071	Socket Head Cap Screw	3/8"-16x1-1/2"	2
67	TS-1550071	Flat Washer	3/8"x3/4"D	1
68	6296089	Key	9.5mmx273mm	1
69	6296088	Spring Pin	4x14mm	1
70	60C-270	Base Slide		1
71	TS-0270051	Socket Set Screw	5/16"-18x1/2"	1
	60B-270	Cutterhead Guard Assembly (Index # 72 thru 77)		1
72	60B-272	Warning Label		1
73	60B-273	Cutterhead Guard		1
74	JSG96-223	Retaining Ring	STW-11	1
75	60B-275	Spring		1
76	60B-276	Shaft		1
77	60B-277	Spring Pin	6x36mm	2
78	60C-278	I.D. Label	1Ph	1
	60C-278A	I.D. Label	3Ph	1
	60HH-278	I.D. Label	1Ph	1
	60HH-278A	I.D. Label	3Ph	1
79	TS-0207021	Socket Head Cap Screw	1/4"-20x1/4"	1
80	60C-280	Stud		1
81	5DF-B05	Knob		1
82	60HH-282	L-Plate (not shown)		2

Base Assembly (60C and 60HH)

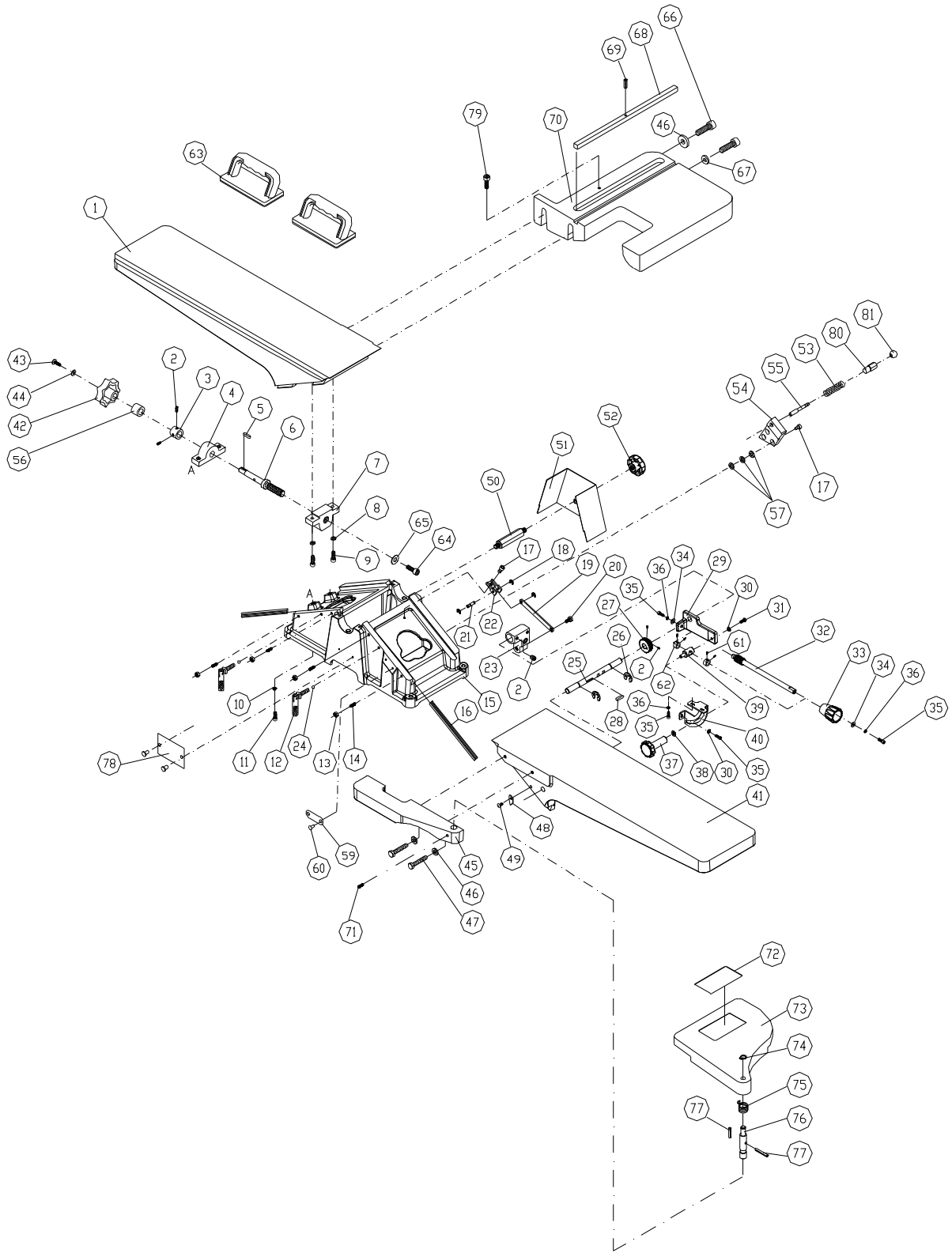

Parts List: Fence Assembly (60C and 60HH)

Index No.	Part No.	Description	Size	Qty
	PJ882-FA	Fence Assembly (Index #1 thru 49)		
1	PJ882-101	Hand Wheel		1
2	TS-0267021	Socket Set Screw	1/4"-20x1/4"	3
3	TS-0207031	Socket Head Cap Screw	1/4"-20x5/8"	4
4	PJ882-104	Bearing Cover		1
5	PJ882-105	C-Ring	STW-12	2
6	PJ882-106	Worm Shaft		1
7	BB-6001ZZ	Ball Bearing	6001ZZ	2
8	PJ882-108	Pin	Ø3x20mm	1
9	TS-0810012	Round Head Slotted Machine Screw	#10-24x1/4"	2
10	TS-0680011	Flat Washer	3/16"	2
11	PJ882-111	Pointer		1
12	6285945	Knob		1
13	6296069	Locking Shaft		1
14	6285944	Handle Stud		1
15	TS-0207021	Socket Head Cap Screw	1/4"-20x1/2"	1
16	6296084	Bolt		1
17	TS-0680061	Flat Washer	1/2"	1
18	PJ882-118	Nylon Nut	1/2"-12	1
19	PJ882-119	Locking Handle		1
20	PJ882-120	Bushing		1
21	PJ882-121	Stop Block		1
22	PJ882-122	Fence Bracket		1
23	PJ882-123	Worm		1
24	PJ882-124	Retaining Ring	RTW-28	1
25	TS-0050031	Hex Cap Screw	1/4"-20x3/4"	1
26	PJ882-126	Rack		1
27	PJ882-127	Locking Handle Nut		1
28	PJ882-128	Locking Link		1
29	TS-0561011	Hex Nut	1/4"-20	3
30	TS-0050051	Hex Cap Screw	1/4"-20x1"	2
31	PJ882-131	Safety Plate		1
32	TS-081F031	Phillips Flat Head Machine Screw	1/4"-20x1/2"	2
33	6296070	Pin	5mmx50mm	1
34	TS-0206021	Socket Head Cap Screw	#10-24x1/2"	5
35	6296073	Screw		1
36	6296082	Fence Link		1
37	6285942	Cone Point Screw		4
38	TS-0561031	Hex Nut	3/8"-16	4
39	TS-0720071	Lock Washer	1/4"	2
40	6285940	Pivot Stud		2
41	TS-0561052	Hex Nut	1/2"-20UNF	2
42	PJ882-142	Fixed Block		1
43	PJ882-143	Fence		1
44	PJ882-144	Insert		1
45	60B-130	Caution Label (Setting Knives)		1
46	60B-129	Caution Label (Hands Clear)		1
47	PJ882-147	Label (Lock/ Unlock)		1
48	PJ882-148	Scale Label		1
49	PJ882-333	Spring Pin	Ø4x25mm	1

Fence Assembly (60C and 60HH)

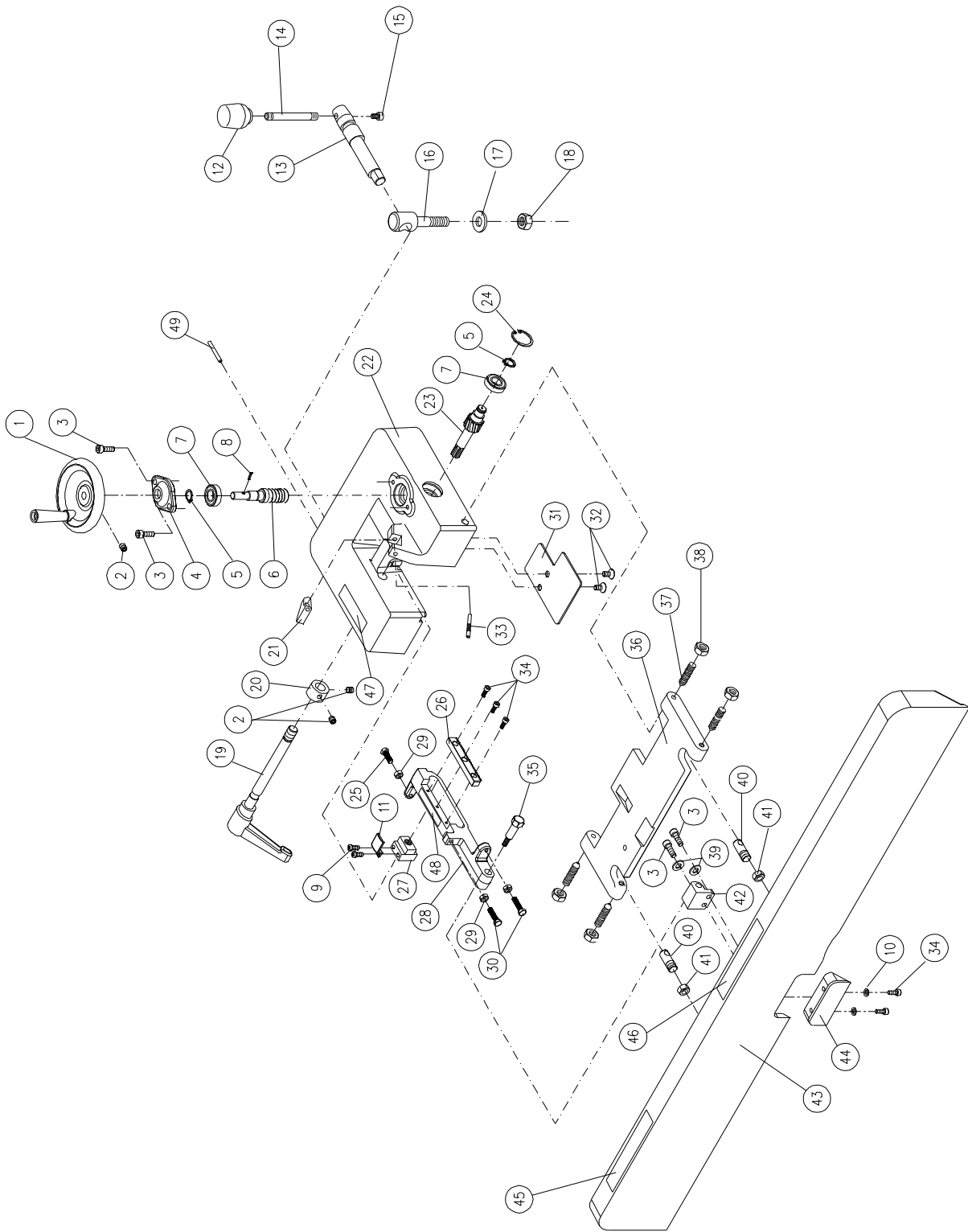

Parts List: Straight Cutterhead Assembly (60C only)

Index No.	Part No.	Description	Size	Qty
.....	60B-300	Cutterhead Assembly (Index # 1 thru 5, and 10 thru 13)		1
1.....	6296046	Knife		3
2.....	6296153	Knife Gib		3
3.....	6296048	Key	5x5x25mm	1
4.....	6296049	Ball Bearing	6203-2NSE	2
5.....	6296050	Bearing Housing		2
6.....	TS-0267021	Set Screw	1/4"-20x1/4"	2
7.....	6296051	Pulley		1
8.....	6285853	Bolt		2
9.....	TS-0720091	Lock Washer	3/8"	2
10.....	6296154	Square Head Screw		15
11.....	6296053	Cutterhead		1
12.....	6296054	Spring		6
13.....	6296055	Flat Head Screw	M5-0.8Px12	6
.....	60B-301	Knife Gauge Assembly (Index # 14, 15, 16)		1
14.....	6296155	Knife Gauge		2
15.....	6296156	Knife Gauge Bar		1
16.....	6296157	E-Clip	ETW-6	2

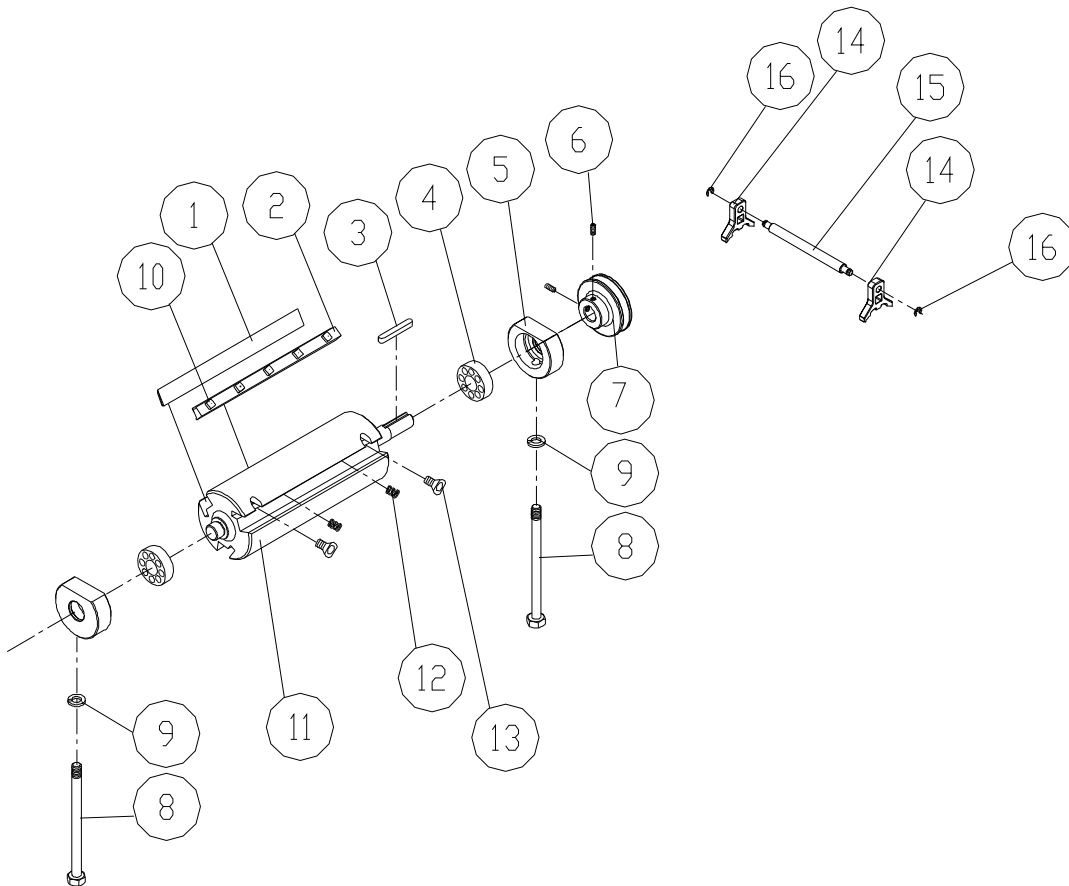

Parts List: Helical Cutterhead Assembly (60HH only)

Index No.	Part No.	Description	Size	Qty
.....	60HH-CA	Cutterhead Assembly (Index #1 thru 8)		1
1.....	TS-0267021	Socket Set Screw	1/4"-20x1/4"	2
2.....	6296051	Pulley		1
3.....	6296050	Bearing Housing		2
4.....	6296049	Ball Bearing	6203-2NSE	2
5.....	JWP208HH-111	Knife Insert Screw	#10-32x1/2"	54
6.....	1791212	Knife Insert (set of 10)		total 54
7.....	6296048	Key	5x5x25mm	1
8.....	60HH-308	Helical Cutterhead		1
9.....	TS-0720091	Lock Washer	3/8"	2
10.....	6285853	Bolt		2
11.....	JJ6HH-113	Star Point Screwdriver (not shown)		2

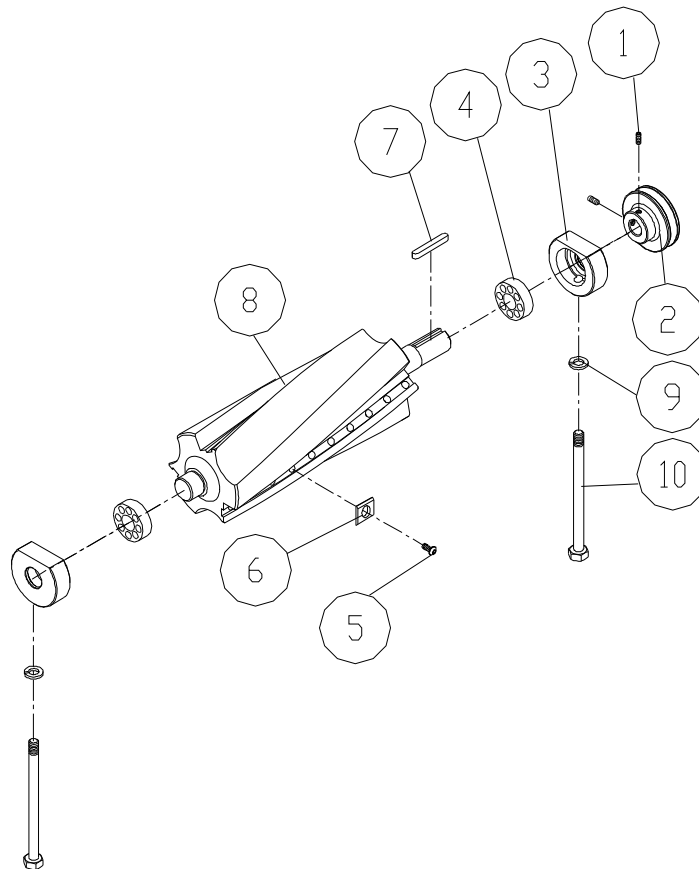

Parts List: Stand Assembly (60C and 60HH)

Index No.	Part No.	Description	Size	Qty
	2365025	60C/60HH Stand Assembly (Index #1 thru 51)	2HP, 1Ph, 230V	1
	2365026	60C/60HH Stand Assembly (Index #1 thru 51)	3HP, 3Ph, 230/460V	1
1	60C-401A	Stand	1Ph	1
	60C-401B	Stand	3Ph	1
2	60B-402	Door		1
3	60B-403	Carriage Bolt	3/8"-16x2-3/8"	3
4	TS-1550071	Flat Washer	3/8"	6
5	TS-1534042	Phillips Pan Head Machine Screw	M6x12	2
6	TS-1550041	Flat Washer	M6	2
7	6285975	Screw Knob		1
8	6285976	Door Lock		1
9	6285977	Hex Nut	3/8"-16	1
10	60B-410	Carriage Bolt	5/16"-18x3/4"	4
11	6285805	Flat Washer	5/16"	4
12	VB-A44	V-Belt	A-44	1
13	60B-413	Motor Pulley		1
14	TS-0267021	Set Screw	1/4"-20x1/4"	2
15	60B-415	Motor	2HP, 1Ph, 230V	1
	60B-415MF	Motor Fan (not shown)		1
	60B-415MFC	Motor Fan Cover (not shown)		1
	60B-415CS	Centrifugal Switch (not shown)		1
	60B-415MDC	Motor Dustproof Cover (not shown)		1
	60B-415CC	Capacitor Cover (not shown)		2
	60B-415SC	Starting Capacitor (not shown)	400MFD, 125VAC	1
	60B-415RC	Running Capacitor (not shown)	30uf, 350VAC	1
	60B-415A	Motor	3HP, 3Ph, 230/460V	1
16	6285988	Lock Washer	5/16"	4
17	6285966	Hex Nut	5/16"-18	1
18	60B-418	Motor Cord	1Ph	1
	60B-418A	Motor Cord	3Ph	1
19	60C-419	Control Switch		1
20	PM2000-298	Safety Key For Switch		1
21	60C-421	Power Cord	1PH	1
	60C-421A	Power Cord	3PH	1
22	60C-422	Switch Arm		1
23	6285909	Flat Washer	1/4"	4
24	6285910	Pan Head Screw	1/4"-20x1/2"	4
25	60B-425	Dust Chute		1
26	6285978	Key	5x5x30mm	1
27	60C-427	Cord Protector		1
28	PJ882-526A	Magnetic Switch	1Ph 230V	1
	PJ882-526ACS	Contactors Switch (not shown)	1Ph 230V	1
	PJ882-526AOR	Overload Relays (not shown)		1
	PJ882-526B	Magnetic Switch	3Ph 230V	1
	PJ882-526BCS	Contactors Switch (not shown)	3Ph 230V	1
	PJ882-526ORA	Overload Relay (not shown)		1
	PJ882-526C	Magnetic Switch	3Ph 460V	1
	PJ882-526CCS	Contactors Switch (not shown)	3Ph 460V	1
	PJ882-526COR	Overload Relay (not shown)		1
29	JWBS18-447	Screw	M5x8	10
30	TS-1550031	Flat Washer	M5	6
31	PJ882-551	Machine Screw	M5x50	2
32	PJ882-548	Switch Plate		1
33	TS-0732041	Star Washer	M5	2
34	TS-0208041	Socket Head Cap Screw	5/16"-18x3/4"	4
35	TS-0720081	Lock Washer	5/16"	4
36	TS-0680031	Flat Washer	5/16"	4

37.....	PM2000-105	Powermatic Nameplate.....	1
38.....	6296150.....	Warning Label.....	1
39.....	60C-439.....	Strain Relief.....	1Ph
	60C-439A	Strain Relief.....	3Ph
40.....	60B-440	Strain Relief.....	1
41.....	60C-441	Motor Label	1Ph
	60C-441A	Motor Label	3Ph
42.....	TS-0720091	Lock Washer	3/8".....
43.....	TS-0570031	Hex Nut.....	3/8"-16.....
45.....	TS-081C022	Phillips Pan Head Machine Screw	#10-24x3/8".....
46.....	60C-446.....	Control Cord.....	1
47.....	60B-447.....	Strain Relief.....	1
	60B-447A.....	Strain Relief.....	1
48.....	60B-448.....	Switch Plate	1
49.....	TS-1533042.....	Phillips Pan Head Machine Screw	M5x0.8x12.....
50.....	PM2700-440	Wide Stripe.....	sold per ft.
51.....	PM2700-441	Narrow Stripe	sold per ft.
52.....	60C-452.....	Cord Plate	1
53.....	TS-0810012.....	Round Head Slotted Machine Screw.....	#10-24x1/4
54.....	PJ882-533	Cord Protector.....	1
55.....	PJ882-557	Junction Box.....	1
56.....	PJ882-558	Junction Box Cover	1
57.....	PJ882-559	Grounding Cord.....	1

Stand Assembly (60C and 60HH)

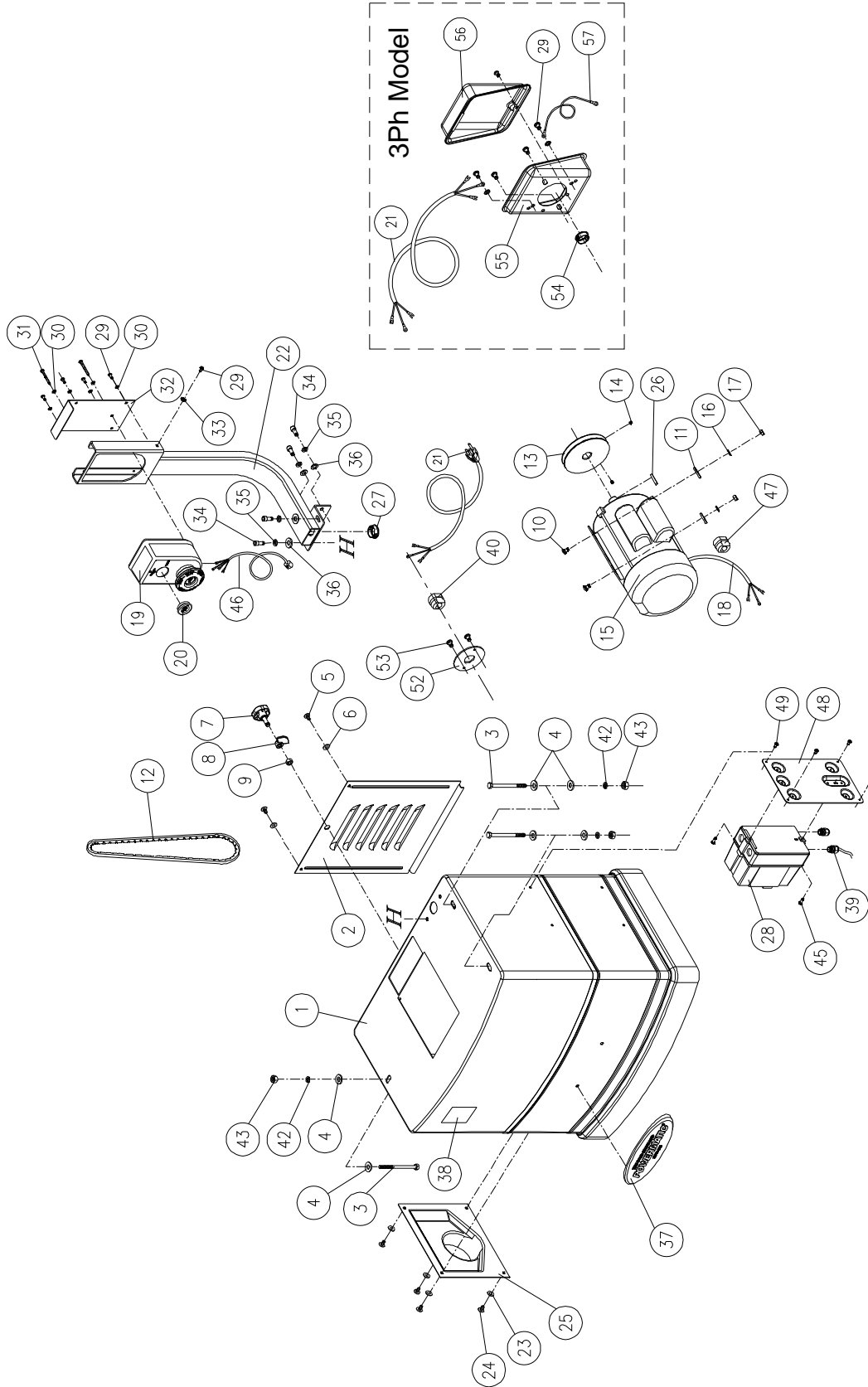

Electrical Connections – 3 Phase, 230 Volt

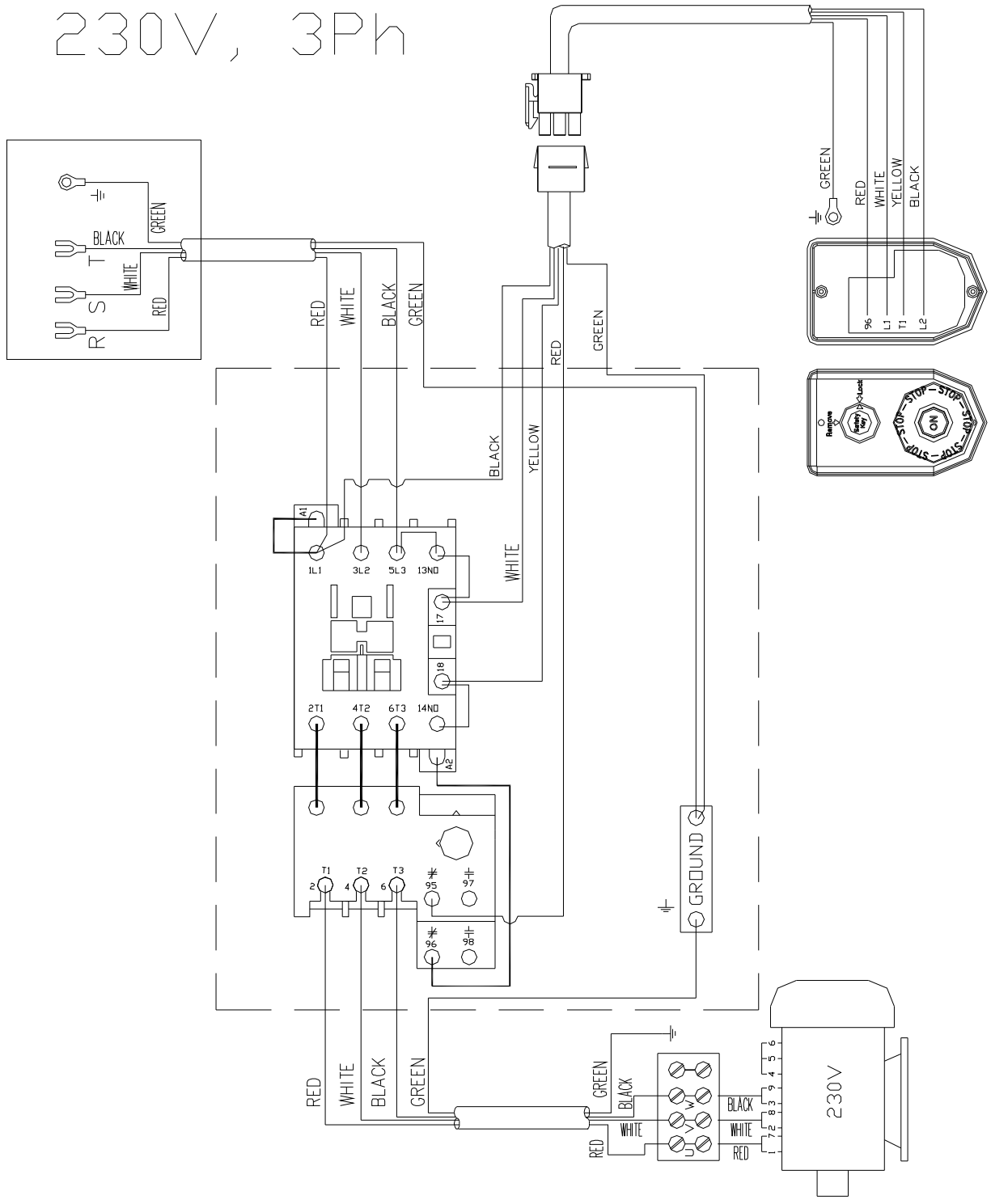

Electrical Connections – 3 Phase, 460 Volt

460V, 3Ph

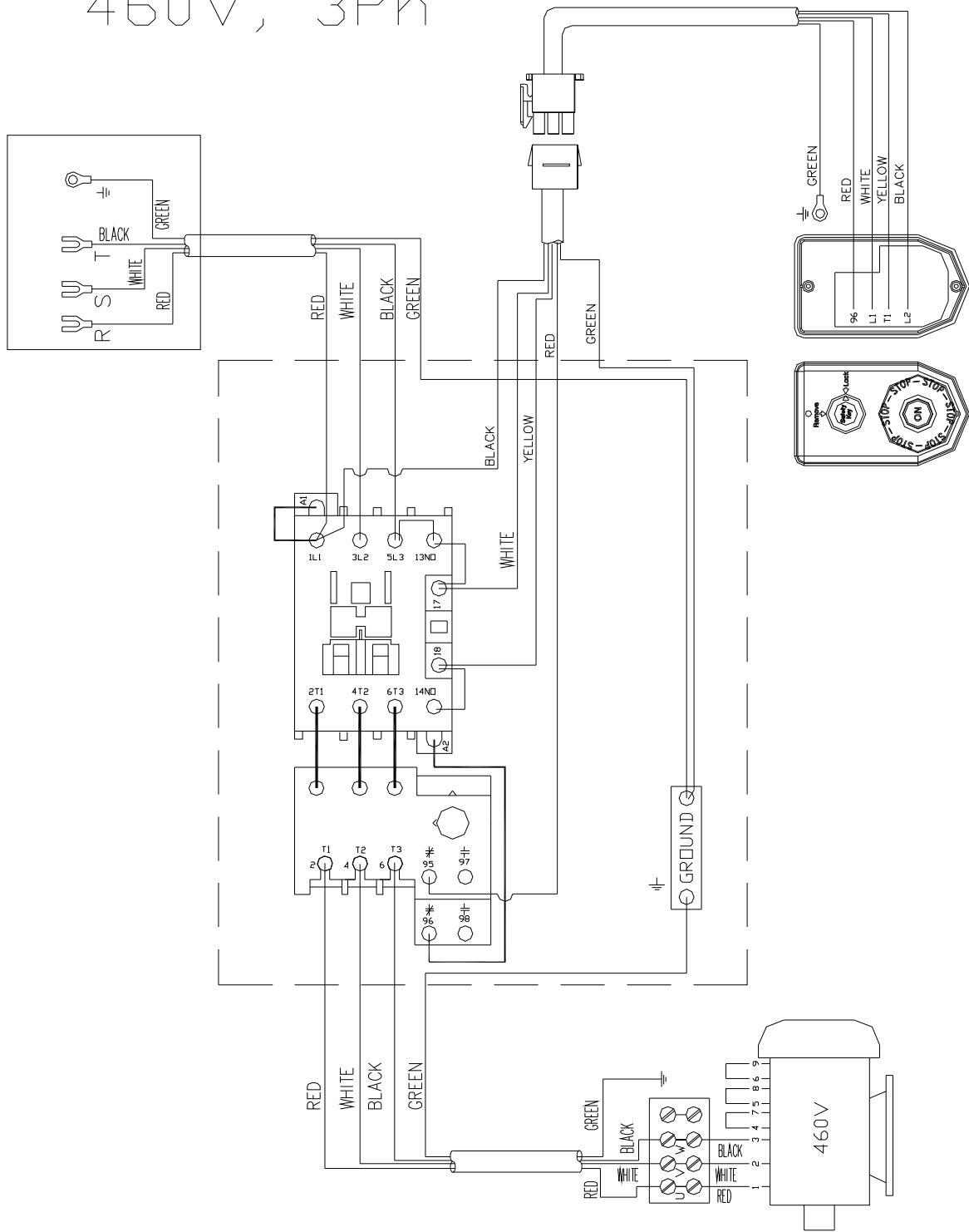



427 New Sanford Rd.
LaVergne, TN 37086
Phone: 800-274-6848
www.powermatic.com