



M165959C

PTO Generator Trailer

ITEM # 165959

For use on 13000, 27500, and 60000
PTOG North Star Generators or Other
PTO Generators up to 60kW.

PLACE MANUAL NAMEPLATE HERE

OWNER'S MANUAL

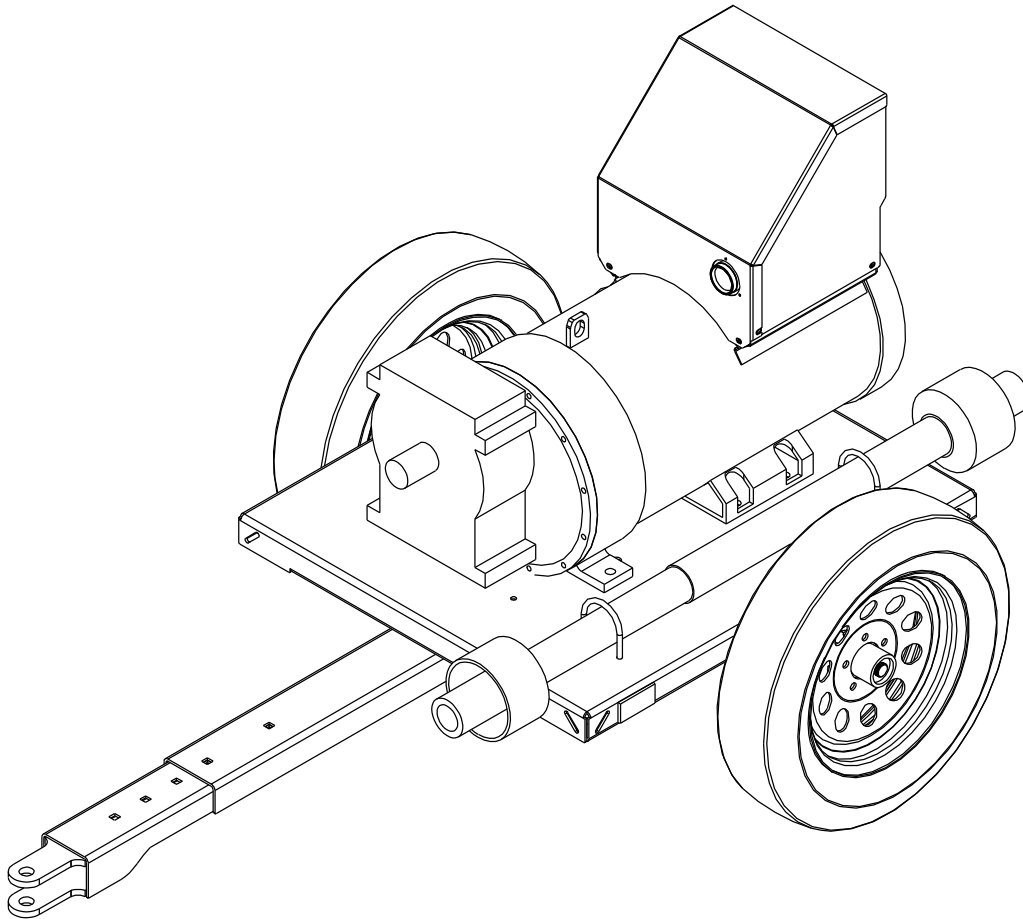

00641

**Any Questions, Comments, or Problems?
Call Customer Service at 1-800-270-0810**

THANK YOU

Thank you for purchasing a NorthStar PTO Trailer. Your trailer is designed for long life, dependability, and the top performance you demand. Please take time now to read through this manual so you can better understand the machine's operation and safety precautions. Everyone who uses this trailer must read and understand this manual. Enjoy the exceptional performance of your NorthStar PTO Trailer.

IMPORTANT

Make certain the operator:

- Reads and understands the manuals pertaining to this trailer and generator.
- Is instructed in safe and proper operation of this trailer and generator.

NOTICE

K-BAR Industries Incorporated reserves the right to make improvements in design and/or changes in specifications at any time without incurring any obligation to install them on units previously sold.

WARNINGS

NEVER load the trailer with more than 1200 lbs.

NEVER use this trailer for PTO Generators over 60 kW.

NEVER exceed 30 mph with this trailer.

ALWAYS replace damaged reflectors.

ALWAYS read your owners manual before operating.

ALWAYS check for loose fasteners before each use.

ALWAYS engage PTO while tractor is idling.

ALWAYS read your PTO Generator manual before operating.

STEP 1

- Open hardware bag and separate the components.

FASTENERS (actual size)

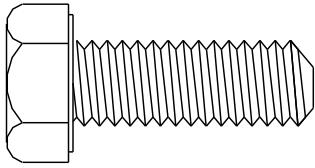

1/2-13 X 1.25" Long
Hex Head Bolt Qty. 8

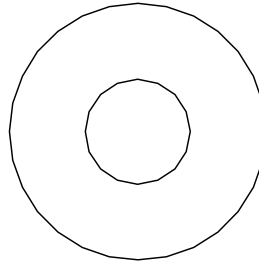

1/2" Flat Washer
Qty. 18

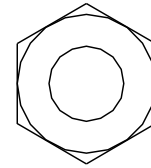

1/2-13 Ny-Loc Nut
Qty. 10

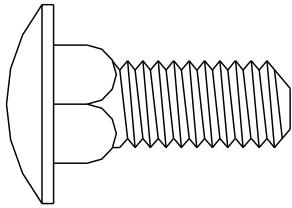

1/2-20 X 1.25" Long
Carriage Bolt Qty. 2

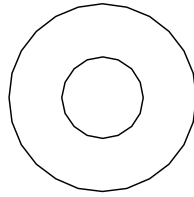

3/8" Flat Washer
Qty. 6

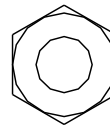

3/8-16 Hex Nut
Qty. 2

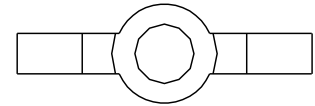

3/8-16 Ny-Loc Wing Nut
Qty. 6

MISCELLANEOUS COMPONENTS (not actual size)



Lug Bolts
Qty. 10

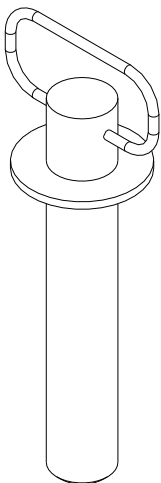

Hitch Pin with Chain
and Lynch Pin
Qty. 1

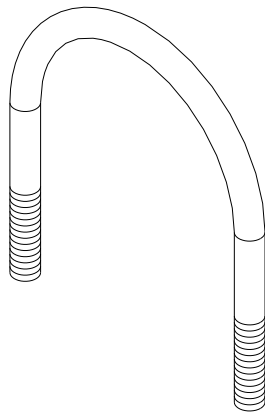

PTO Implement
Shaft Retainer
Qty. 2



Cord Hooks
Qty. 2

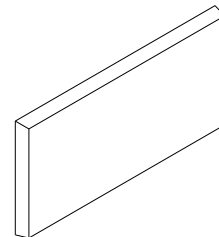

Red Reflector
Qty. 2

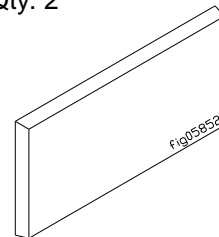

Amber Reflector
Qty. 2

STEP 2

- Remove remaining components from the box. Discard unpainted shipping bracket. Place trailer Base on two supports at least twelve(12) inches high.

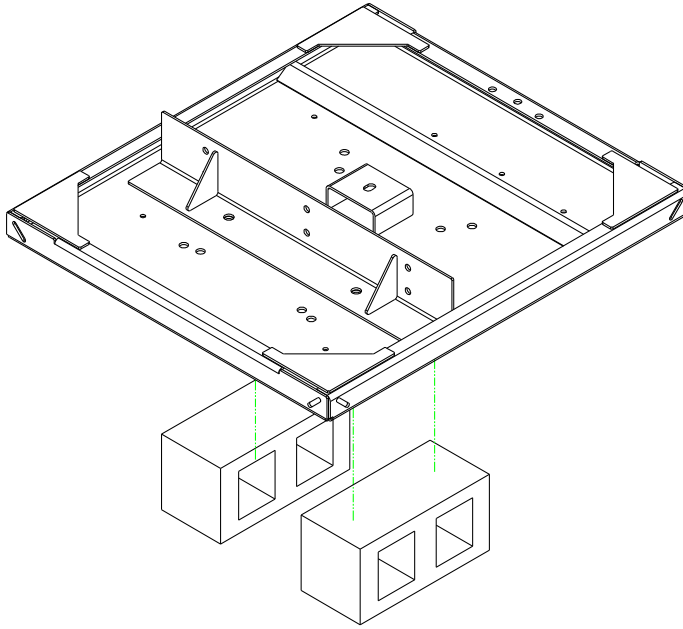

00673

STEP 3

- Bolt the Axle to the Base with (6) 1/2"-13 x 1.25 hex head bolts, (12) 1/2" flat washers, and (6) 1/2-13 Ny-Loc nuts.

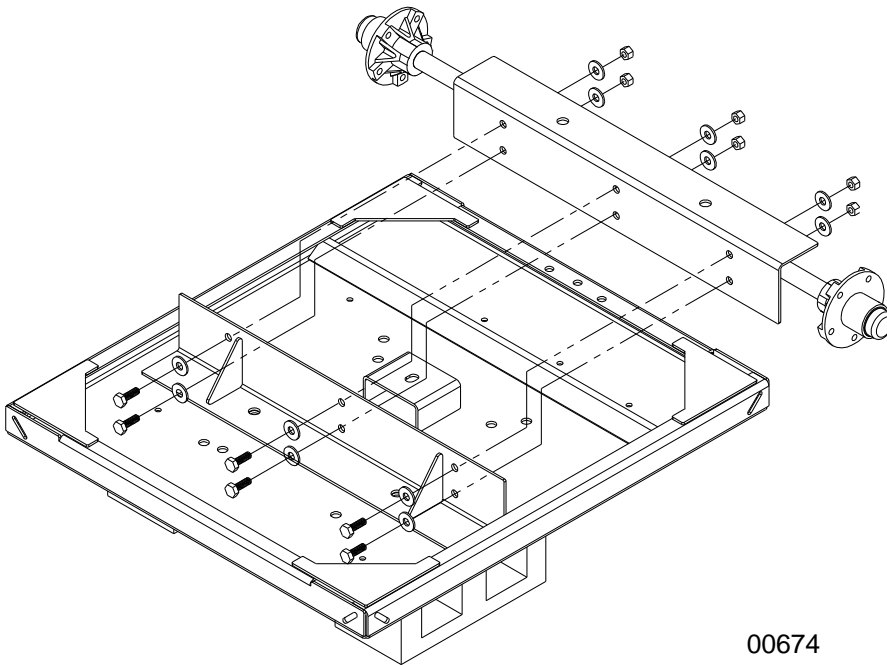

00674

STEP 4

- Assemble Tongue Arm to Base with (2) 1/2-13 X 1.25" hex head bolts, (4) 1/2 Flat Washers, and (2) 1/2-13 Ny-Loc Nuts. Assemble Tongue to Tongue Arm with (2) 1/2-13 X 1.25 Carriage bolts, (2) 1/2 flat washers, and (2) 1/2-13 Ny-Loc nuts. Note: The Tongue Arm and Tongue is adjustable to fit many different PTO Generators and PTO Implement Shafts. You may need to adjust the Tongue to fit your implement shaft. The Tongue Arm pivots and is adjustable to fit different PTO Generators, if you have a NorthStar PTO Generator use the center hole.

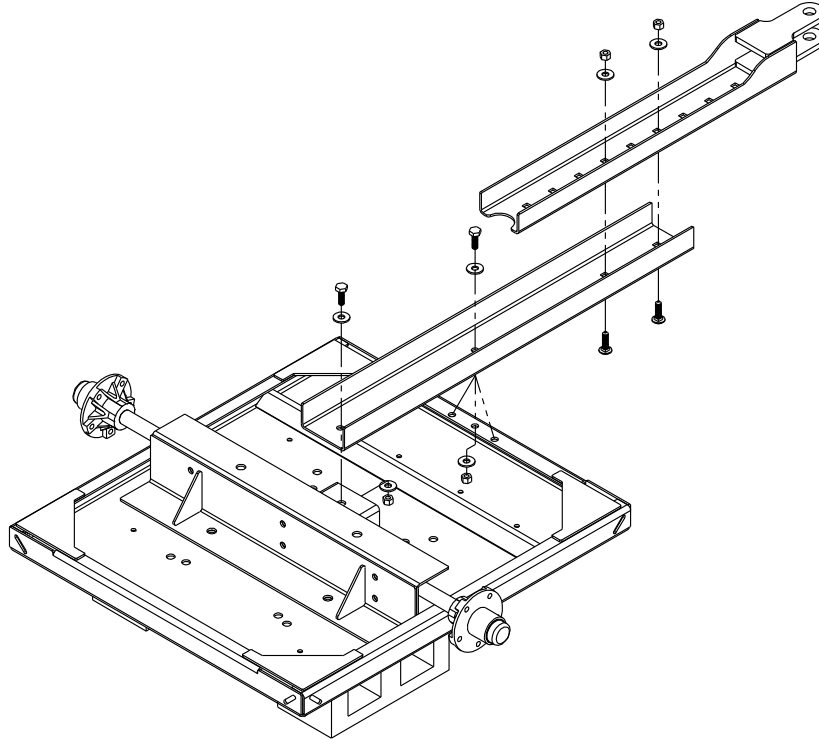

00675

STEP 5

- Assembly wheels to hubs with the 10 lug nuts.

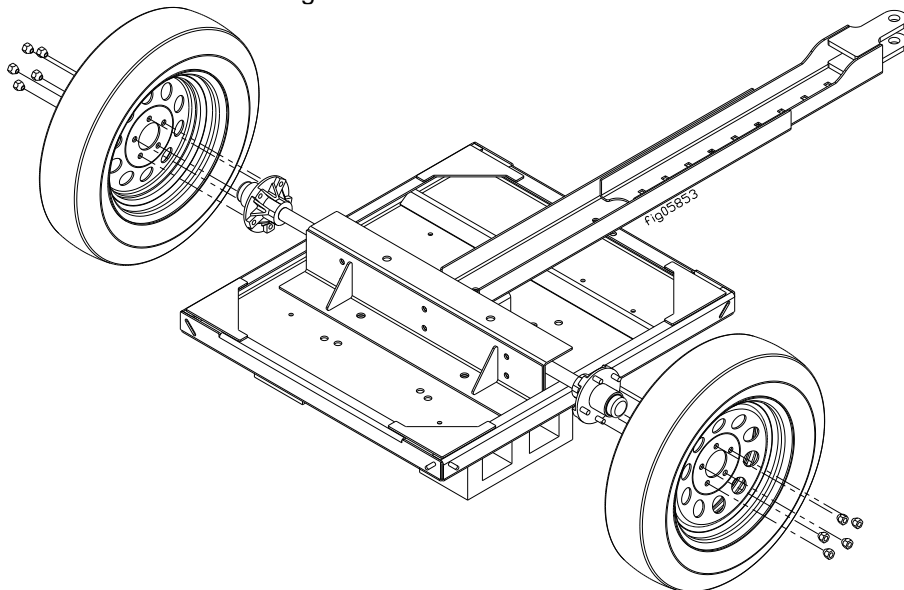

STEP 6

- Apply the (2) red reflectors to the rear of the trailer and (2) amber reflectors to front sides of the trailer as shown. Assemble the (2) cord hooks to the trailer with (2) 3/8-16 hex nuts, (2) 3/8 flat washers, and (2) 3/8-16 Ny-Loc wing nuts. Assemble the (2) PTO Implement shaft retainer to the trailer with (4) 3/8 flat washers, and (4) 3/8-16 Ny-Loc wing nuts. Discard any remaining fasteners.

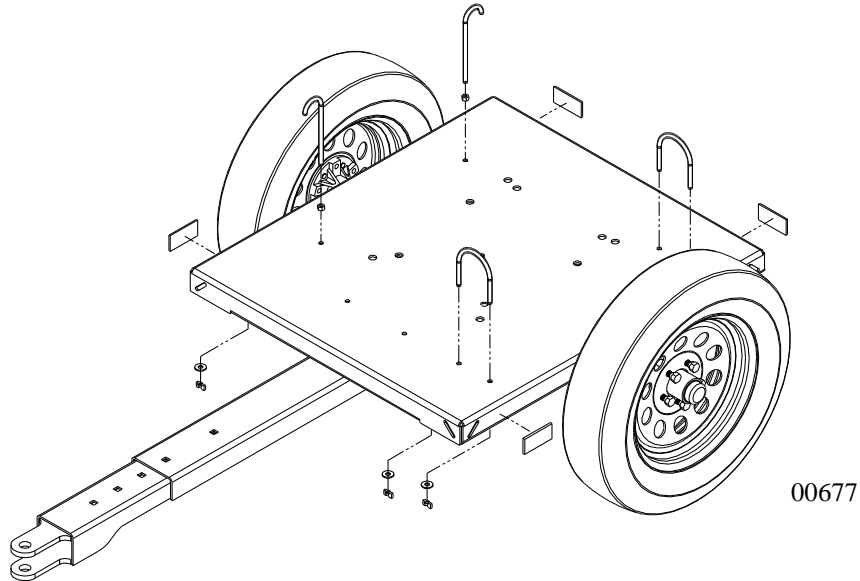

STEP 7

- Mount NorthStar PTO Generators to trailer using one of the three following bolt patterns. For other PTO

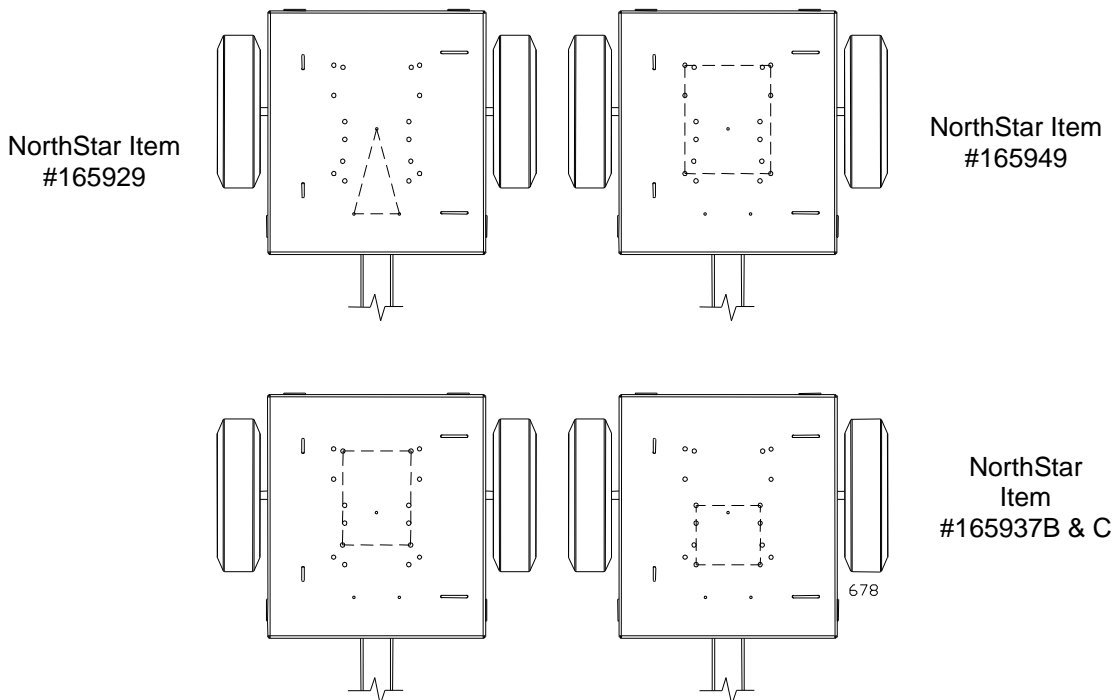

Generators you may need to drill mounting holes.

Maintenance

Item	Function Required	3 Months or 1000 Miles	12 Months or 6000 Miles
Bearings	Inspect for wear, clean and repack		•
Seals	Inspect for leakage, Replace in worn		•
Spindle Nut	Check torque value and tightness		•
Wheel Nuts	Check torque value	•	

Ultra Pack Hub Lubrication

This hub has the Ultra Pack lubrication system included. The bearings can be periodically lubricated without removing the hub from the spindle.

Step 1: Remove the rubber dust cap plug.

Step 2: Use a grease gun and pump grease into the grease fitting on the rear of the hub, while slowly rotating the hub.

Step 3: The old grease will be pushed out of the hub and out through the dust cap. As the new fresh grease exits the dust cap, remove the grease gun and re-insert the rubber dust cap plug.

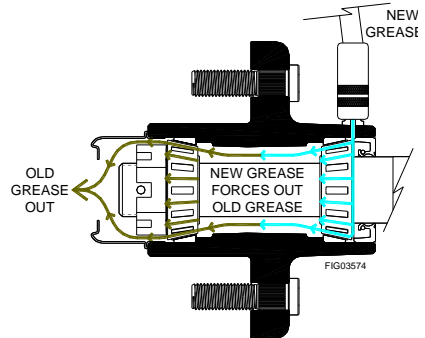

Exploded View – Rev. C

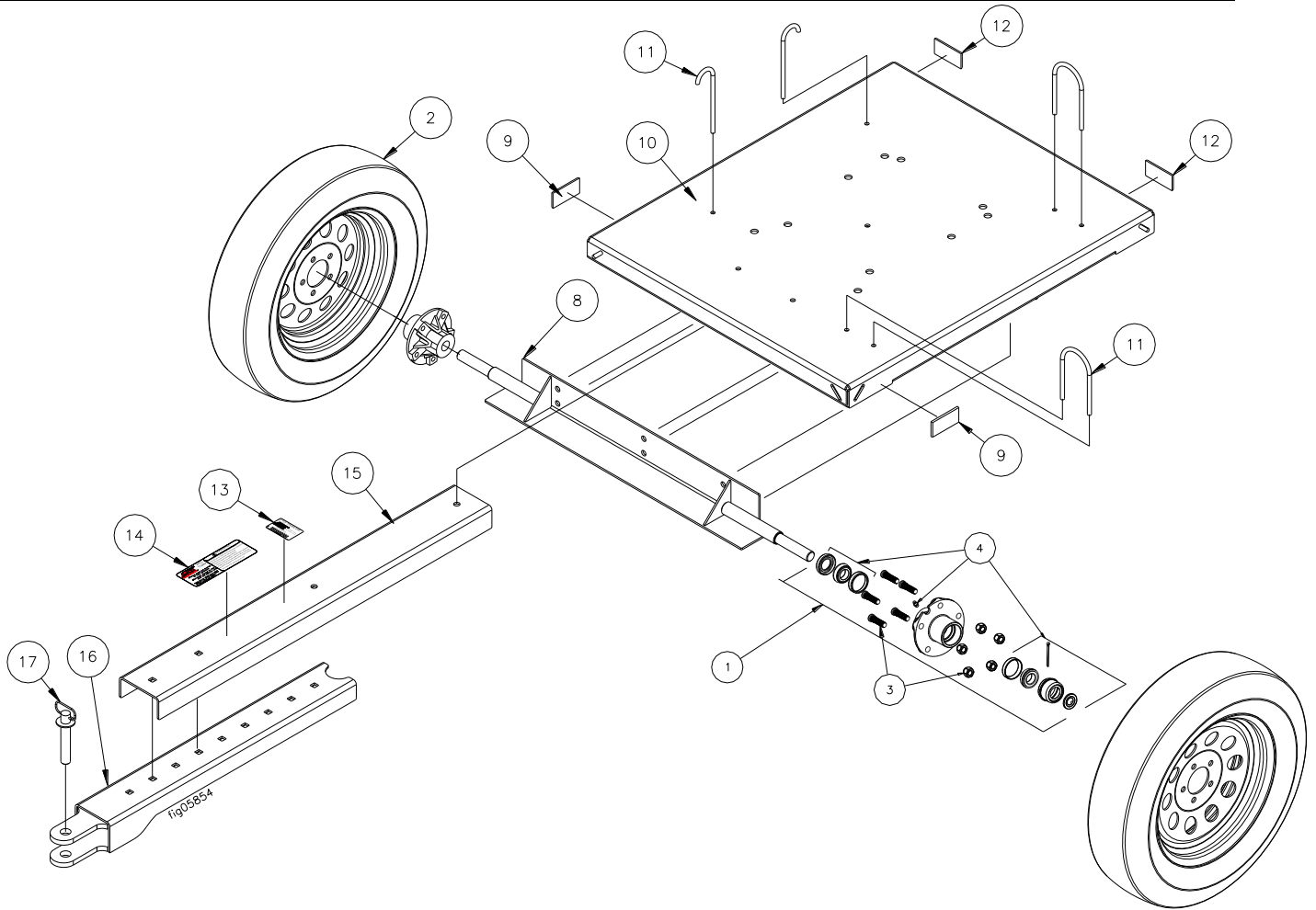

Diag #	Part #	Description	Qty
1	794906	Hub Assembly	2
2	780199	Tire, 13"LRB 5H	2
3	783925	Lug Stud and nut kit	10
4	785446	Bearing Renew Kit(includes oil seal, bearings, dust cap, cotter pin, and grease zerk)	2
8	34198	Axle	1
9	34215	Amber Reflector	2
10	34197	Base	1
11	34201	Bolt Bag	1
12	34215	Red Reflector	2
13	35068	Nameplate	1
14	34205	Decal	1
15	34187	Pivot Tongue	1
16	34199	Tongue	1
17	34226	Hitch Pin W/ Chain and Lynch Pin	1