

ASPEN II STRIP w/SLE Software

GEM Software Manual



Main Home Page

**Appendix B:
Equipment Constants**

**Appendix H:
Formatted Process Programs**

Table of Contents

**Appendix C:
Event IDs**

**Appendix I:
Programming Examples**

SECS I Hardware

**Appendix D:
Variable IDs**

**Appendix J:
Event Report File Structure**

SECS II Message Summary

**Appendix E:
Remote Commands**

**Appendix K:
Material Handling Diagram**

SECS II Messages

**Appendix F:
Remote Control Operation**

**Appendix L:
Aspen SECS II Scenarios**

State Diagrams and Transition Tables

**Appendix G:
Process Program Descriptions**

**Appendix M:
SML File**

**Appendix A:
Alarm IDs**



Aspen II SLE SECS II/GEM Manual

Service Information

Mattson's Technical Support and Customer Support Departments are open 24 hours per day, 7 days per week. Please have your model number, serial number, and phone number ready when you call any of the numbers listed on this page.

Global Customer and Technical Support

Contact Customer Support for billing and shipping questions, field support for warranty and installation questions. Customer support will direct your service call to the appropriate department, such as Technical Support or Spare Parts.

Phone: 1 (800) 315-6607 (USA, toll-free, 24/7) or
(845) 575-6203 (International, 24/7)
FAX: (510) 226-8241

Plasma Products Global Technical Support

email: plasmaproductstechsupport@mattson.com

Spare Parts

Contact Spare Parts for spare parts orders.

Phone: 1 (800) 315-6607 (USA, toll-free, 24/7) or
(845) 575-6203 (International, 24/7)
FAX: (510) 492-6369 (USA/Asia)
(610) 280-8407 (Europe)
email: partssupport@mattson.com

Mattson Corporate Headquarters

2800 Bayview Drive
Fremont, CA 94538
Tel: (510) 657-5900
email: info@mattson.com
On the web at: www.mattson.com

About this Manual

Contact Mattson Technical Publications for additions or corrections to this Manual at techpubs@mattson.com

Disclaimer

Mattson Technology, Inc. makes no representations or warranties with respect to this manual, except as outlined in the product warranty. Further, Mattson reserves the right to make changes in the specifications of the product described in the manual at any time, without notice, and without obligation to Mattson Technology.

Copyright ©2002 by Mattson Technology Inc.

Copyright under International, Pan American, and Universal Copyright Conventions. All rights reserved. This manual may not be reproduced, either wholly or in part, for any reason whatsoever, without the prior written permission of Mattson Technology, Inc.

TABLE OF CONTENTS

1.0	SECS I Hardware	1-1
1.1	Applicable Equipment	1-1
1.2	SECS I Hardware	1-1
1.3	Loading The SIB	1-1
1.4	SIB Configuration	1-1
1.5	Equipment Monitoring of Host and Message Spooling	1-3
1.6	Software Revision	1-3
2.0	Support SECS II Message Summary	2-1
3.0	Supported SECS II Messages	3-1
3.1	SxF0	3-1
	SxF0 Abort Transaction	3-1
3.2	S1Fx	3-1
	S1F1 Are You There Request (R)	3-1
	S1F2 On Line Data (D)	3-1
	S1F3 Selected Equipment Status Request (SSR)	3-1
	S1F4 Selected Equipment Status Data (SSD)	3-2
	S1F9 Material Transfer Status Request (TSR)	3-2
	S1F10 Material Transfer Status Data (TSD)	3-2
	S1F11 Status Variable Namelist (SVNR)	3-2
	S1F12 Status Variable Namelist Reply (SVNRR)	3-3
	S1F13 Establish Communication Request (ECR)	3-3
	S1F14 Establish Communications Request Acknowledge (CRA)	3-3
	S1F15 Request OFF-LINE (ROFL)	3-4
	S1F16 OFF-LINE Acknowledge	3-4
	S1F17 Request ON-LINE (RONL)	3-4
	S1F18 ON-LINE Acknowledge (ONLA)	3-4
3.3	S2Fx	3-4
	S2F13 Equipment Constant Request (ECR)	3-4
	S2F14 Equipment Constant Data (ECD)	3-5
	S2F15 New Equipment Constant Send (ECS)	3-5
	S2F16 New Equipment Constant Acknowledge (ECA)	3-5
	S2F17 Date and Time Request (DTR)	3-5
	S2F18 Date and Time Data (DTD)	3-6
	S2F21 Remote Command Send (RCS)	3-6
	S2F22 Remote Command Acknowledge (RCA)	3-6
	S2F23 Trace Initialize Send (TIS)	3-6
	S2F24 Trace Initialize Acknowledge (TIA)	3-7
	S2F25 Loopback Diagnostic Request (LDR)	3-7
	S2F26 Loopback Diagnostic Data (LDD)	3-7
	S2F27 Initiate Processing Request (IPR)	3-7
	S2F28 Initiate Processing Acknowledge (IPA)	3-8
	S2F29 Equipment Constant Namelist Request (ECNR)	3-8

Table of Contents

	S2F30	Equipment Constant Namelist (ECN)	3-8
	S2F31	Date and Time Set Request (DTS)	3-8
	S2F32	Date and Time Set Acknowledge (DTA)	3-9
	S2F33	Define Report (DR)	3-9
	S2F34	Define Report Acknowledge (DRA)	3-10
	S2F35	Link Event Report (LER)	3-10
	S2F36	Link Event Report Acknowledge (LERA)	3-11
	S2F37	Enable/Disable Event Report (EDER)	3-11
	S2F38	Enable/Disable Event Report Acknowledge (EERA)	3-11
	S2F39	Multi-Block Inquire (DMI)	3-11
	S2F40	Multi-Block Grant (DMBG)	3-12
	S2F41	Host Command Send (HCS)	3-12
	S2F42	Host Command Acknowledge (HCA)	3-12
	S2F43	Reset Spooling Streams and Functions	3-13
	S2F44	Reset Spooling Acknowledge (RSA)	3-14
	S2F45	Variable Limit Attribute Request (VLAR)	3-14
	S2F46	Variable Limit Attribute Acknowledge (VLAA)	3-15
	S2F47	Variable Limit Attribute Request (VLAR)	3-16
	S2F48	Variable Limit Attributes Send (VLAS)	3-16
3.4	S3Fx		3-17
	S3F11	Material ID Request (MIDR)	3-17
	S3F12	Material ID Request Acknowledge (MIRA)	3-17
	S3F13	Material ID Send	3-17
	S3F14	Material ID Acknowledge	3-18
3.5	S4Fx		3-18
	S4F1	Ready to Send Material (RSN)	3-18
	S4F2	Ready to Send Acknowledge (RSA)	3-18
	S4F3	Send Material (SMN)	3-18
	S4F5	Handshake Complete (HCN)	3-19
	S4F7	Not Ready to Send (ABN)	3-19
	S4F9	Stuck in Sender (SSN)	3-19
	S4F11	Stuck in Receiver (SRN)	3-19
	S4F13	Send Incomplete Time-Out (SIN)	3-20
	S4F15	Material Received (MRN)	3-20
	S4F17	Request to Receive Material (RTR)	3-20
	S4F18	Request to Receive Acknowledge (RRA)	3-20
3.6	S5Fx		3-21
	S5F1	Alarm Report Send (ARS)	3-21
	S5F2	Alarm Report Acknowledge (ARA)	3-21
	S5F3	Enable/Disable Alarm Send (EAS)	3-21
	S5F4	Enable/Disable Acknowledge (EAA)	3-22
	S5F5	List Alarms Request (LAR)	3-22
	S5F6	List Alarm Data (LAD)	3-22
	S5F7	List Enabled Alarm Request (LEAR)	3-22
	S5F8	List Enabled Alarm Data (LEAD)	3-22
3.7	S6Fx		3-23
	S6F1	Trace Data Send (TDS)	3-23
	S6F2	Trace Data Acknowledge (TDA)	3-23
	S6F3	Discrete Variable Data Send (DVS)	3-23
	S6F4	Discrete Variable Data Acknowledge (DVA)	3-24
	S6F5	Multi-Block Data Send Inquire (MBI)	3-24

	S6F6	Multi-Block Grant (MBG)	3-24
	S6F9	Formatted Variable Send (FVS)	3-25
	S6F10	Formatted Variable Acknowledge (FVA)	3-25
	S6F11	Event Report Send (ERS)	3-25
	S6F12	Event Report Acknowledge (ERA)	3-26
	S6F13	Annotated Event Report Send (AERS)	3-26
	S6F14	Annotated Event Report Acknowledge (ERA)	3-27
	S6F15	Event Report Request (ERR)	3-27
	S6F16	Event Report Data (ERD)	3-27
	S6F17	Annotated Event Report Request (AERR)	3-27
	S6F18	Annotated Event Report Data (AERD)	3-27
	S6F19	Individual Report Request (IRR)	3-28
	S6F20	Individual Report Data (IRD)	3-28
	S6F21	Annotated Individual Report Request (IRR)	3-28
	S6F22	Individual Report Data (IRD)	3-28
	S6F23	Request Spooled Data (RSD)	3-29
	S6F24	Request Spooled Data Acknowledgment Send	3-29
3.8	S7Fx		3-29
	S7F1	Process Program Load Inquire (PPI)	3-29
	S7F2	Process Program Load Grant (PPG)	3-29
	S7F3	Process Program Send (PPS)	3-30
	S7F4	Process Program Acknowledge (PPA)	3-30
	S7F5	Process Program Request (PPR)	3-30
	S7F6	Process Program Data (PPD)	3-30
	S7F7	Process Program ID Request (PIR)	3-30
	S7F8	Process Program ID Data (PID)	3-31
	S7F17	Delete Process Program Send (DPS)	3-31
	S7F18	Delete Process Program Acknowledge (DPA)	3-31
	S7F19	Current EPPD Request (RER)	3-31
	S7F20	Current EPPD Data (RED)	3-31
	S7F23	Formatted Process Program Send (FPS)	3-32
	S7F24	Formatted Process Program Acknowledge (FPA)	3-32
	S7F25	Formatted Process Program Request (FPR)	3-32
	S7F26	Formatted Process Program Data (FPD)	3-33
	S7F65	Route Upload Request (RUR)	3-33
	S7F66	Route Upload (RUP)	3-34
	S7F67	Route Download (RDL)	3-34
	S7F68	Route Download Acknowledge (RDA)	3-34
	S7F71	Non-Route Process Program Load Inquire (NPPI)	3-35
	S7F72	Non-Route Program Load Grant (NPPG)	3-35
	S7F73	Non-Route Formatted Process Program Send (NFPS)	3-36
	S7F74	Non-Route Formatted Process Program Acknowledge (NFPA)	3-36
	S7F75	Non-Route Formatted Process Program Request (NFPR)	3-36
	S7F76	Non-Route Formatted Process Program Data (NFPD)	3-37
3.9	S9Fx		3-37
	S9F1	Unrecognized Device ID (UDN)	3-37
	S9F3	Unrecognized Stream Type (USN)	3-37
	S9F5	Unrecognized Function Type (UFN)	3-37
	S9F7	Illegal Data (IDN)	3-37
	S9F9	Transaction Timer Time-Out (TTN)	3-38
	S9F11	Data Too Long (DLN)	3-38

Table of Contents

	S9F13	Conversation Time-Out (CTN)	3-38
3.10	S10Fx		3-38
	S10F1	Terminal Request (TRN)	3-38
	S10F2	Terminal Request Acknowledge (TRA)	3-38
	S10F3	Terminal Display, Single (VTN)	3-38
	S10F4	Terminal Display, Single Acknowledge (VTA)	3-39
	S10F5	Terminal Display, Multi-Block (VTN)	3-39
	S10F6	Terminal Display, Multi-Block Acknowledge (VMA)	3-39
4.0	State Diagrams and Transition Tables		4-1
4.1	Communication State		4-1
4.2	Control State		4-3
4.3	Processing State		4-5
4.4	Limit State		4-7
4.5	Alarm State		4-8
	Appendix A—Alarm IDs		A-1
	Appendix B—Equipment Constants		B-1
	Appendix C—Event IDs		C-1
	Appendix D—Variable IDs		D-1
	Appendix E—Remote Commands		E-1
	Appendix F—Remote Control Operation		F-1
	Using S4 Functions to Remove Cassettes from the Aspen Equipment		F-1
	Using S4 Functions to Insert Cassette into the Aspen Equipment		F-2
	Cassettes Transfer Without S4 Messages		F-2
	Aspen Requests to Open Cassette Door		F-2
	Wafer Location Requests		F-2
	Appendix G—Process Program Body Description		G-1
	Appendix H—Formatted Process Program		H-1

Appendix I—Programming Examples I-1

S2F15 New Equipment Constant Send I-1

S2F23 Trace Initialize Send I-1

S2F23 Delete Trace Send I-1

S3F13 Material ID Send I-2

S2F33 Define Report Send I-2

S2F35 Link Event Send I-2

S2F37 Enable All Events Send I-2

Appendix J—Event Report Configuration File Structure J-1

Appendix K—Material Handling Diagram K-1

Appendix L—Aspen SECS II Scenarios L-1

Scenario Semi-Auto Mode / Remote Mode L-1

Scenario Full-Auto Mode/AGV Mode L-5

Appendix M—SML File M-1

Table of Contents

1.0 SECS I Hardware

1.1 Applicable Equipment

This document is applicable to the Aspen II Strip, ICPsm and Lite Etch semiconductor processing equipment manufactured by Mattson Technology, Inc. It is not applicable to the Aspen II CVD or RTP systems.

1.2 SECS I Hardware

The Aspen computer system is equipped with a GW Associates SECS I Interface Board (SIB301) which handles communication between the Aspen equipment and the SECS host computer.

The SIB is linked to the system using a DB-25 female connector. Using RS232C, the SIB transmits on pin 2, receives on pin 3, and uses pin 7 for common.

The SECS I Interface Board supports bi-directional communication with contention resolution by means of using the ENQ, EOT, and ACK protocol. System bytes are used with the message transaction and are represented by way of bytes 7 through 10 of the block header. Message interleaving and multi-open transactions are supported by the SECS I protocol.

1.3 Loading The SIB

The SIB requires that software be loaded from a program file to the board each time the computer is cold-started. To perform this loading manually, enter <loadsib> and the program will load the SIB and give diagnostic messages to the user. Each time the Aspen equipment control program is executed, the SIB operation is automatically examined. If the SIB is found not to be operating, the software automatically reloads the SIB and restarts its operation. If the SIB does not become operational during the restart procedure, then a message stating that the SIB is unusable will be displayed. For automatic board loading, the "loadsib" file must exist in the /user/qnx directory.

1.4 SIB Configuration

In order for the SIB to properly interface with the local SECS system, various parameters must be configured on the SIB. The parameters are stored in a disk file called CFGSIB.DAT. Each time the Aspen equipment control program is executed, the configuration file is read into the SIB. To create or edit the configuration file, enter <edcfg>. The upper part of the display will show the current configuration. If the configuration file does not exist, then the display will show the default parameter settings. When the editing program is executed, the operation of the SIB is checked and the status of the SIB is displayed in the upper right hand corner. If the SIB is found to be operating, then it will display "SIB is Running"; otherwise, "SIB is down" will be displayed. The display will also show a customer identification number. This number is used for software control and portability. The lower part of the display provides editing selections. To edit a selected parameter, enter the first letter of the selection. If an out-of-range value is entered for the selection, the default value will be automatically entered for that selection. The upper part of the display will reflect the changes made by editing.

The configuration editor can be used to ascertain the type of problem the SIB may have if the SIB does not become operational. When exiting the editor, the editor configures the SIB with the current data from the editor and then checks the SIB status. If the check fails, the editor will display the errors to the user.

[C]ustomer ID:

Provides editing of the customer identification number. The customer number range is from 0 through 32767. Default is 0. The customer number is used to define the file name for the file used to configure the S6F3 static report generation. Other customer specials in software may be enabled by their specific Customer ID.

[D]evice ID:

The device number is the number that identifies the device to a node or a host. The device number range is from 0 through 32767. Default is 0.

[P]rotocol:

Protocol describes the type of communication being used. SECS is the only standard protocol the Aspen system supports. The system does allow the user to append additional sub-protocols to the fixed SECS protocol. If AS1F2 is included, then the SIB will automatically reply to the host S1F1 primary message without the Aspen application program operating. If AS2F26 is included, then the SIB will automatically answer the host's loopback S2F25 call without operation of the Aspen application program. To include or exclude these protocols, enter the protocol selection and answer [Y]es or [N]o to the selection questions.

[B]aud Rate:

The available baud rates are: 19200, 9600, 4800, 2400, 1200, 600, 300, 150, and 110. The default baud rate is 9600. Baud rate 19200 has been verified to work on current software.

[T]imers:

T1: Inter Character Time-out, accepts values from 0.1 through 25.5 seconds. Default value is 0.5 seconds.
T2: Block Protocol Time-out, accepts values from 0.1 through 25.5 seconds. Default value is 3.0 seconds.
T3: Reply Time-out, accepts values from 1.0 through 120 seconds. Default is 30.0 seconds.
T4: Inter Block, accepts values from 1.0 through 120 seconds. Default is 10.0 seconds.

[R]etry:

Retry parameter accepts values from 0 through 31. Default is 3.

[S]4 Cassette Transfer Message:

Use S4 Messages to do the cassette transfer in remote control mode. Default is No.

[I]dle Notification Timer:

Aspen will send the report to the host if the system is in idle longer than the specified time. Default is 0 hours and no report will be sent to the host. Units are hours.

[Q]uit:

Exits the configuration editor without saving the configuration data to disk along with not configuring the SIB with the currently displayed parameters.

[E]xit:

Exits the configuration editor along with saving the currently displayed parameters and configuring the SIB with the same parameter values.

1.5 Equipment Monitoring of Host and Message Spooling

The Aspen equipment supports establishing communications with the host. By default, the Aspen equipment uses the S1F1 message. The host can change this to S1F13 by using the S2F15 New Equipment Constant message. [See details in the S2F15 description.](#) The Equipment Constant, the defined reports, report enabling, event linkage to report, spooling enabling and data constants received from the host will be stored on disk and will be reloaded each time the Aspen equipment is rebooted.

Each time the Aspen operational control software is executed, the software will send a S1F1 (or S1F13) formatted message to the host to determine if the host is online. If there is no reply from the host, the Aspen will assume that the host is down and will not attempt to send any equipment-generated messages to the host. Aspen will only resend the S1F1 (or S1F13) message once every minute until the host responds to the Aspen equipment. If a reply or a back online message S1F1 (or S1F13) has been received by the equipment in three pollings, any equipment-generated messages will be sent to the host. Otherwise, the equipment-generated messages will be moved to the spooling queue or be dropped, depending on whether the message is being predefined as spooling enabled or disabled. Once the equipment has received a reply or a back online message, the equipment changes its not-communicating status to communicating status and waits for a S6F65 spool command message from the host to determine how to dispense the messages.

The host may preselect the streams and functions that are to be spooled by using the S2F65 message. The default setup is with all messages disabled.

Anytime that a message sent to the host fails in the transaction, the host will be assumed to be down and the equipment will again retry the host with a S1F1 (or S1F13) message once every minute until the host is found to be online. During the time that the host is offline, the spooling scheme will be active.

If the equipment receives a primary message besides S1F1 and S1F13 from the host during the time that the equipment sees the host condition as being down, the Aspen will ignore the message and will continue to resend a S1F1 or S1F13 message to the host once every minute. When the communication line is established, the equipment spooled messages will not be automatically sent but held in the spooler waiting the S6F65 Spool Reset message from the host.

Each message generated by the equipment will automatically be placed into a message spool from which the message is sent to the host. If the sending of the message to the host fails, the message will remain in the spool. If the message is successfully sent to the host, the message will be removed from the spool. If the equipment attempts to send the message more than twice and the host continues to reject that one message while accepting the S1F1 (or S1F13) message, then the Aspen equipment will drop the message from the spool. All spooled messages are sent first-in, first-out.

Approximately 250 messages can be stored in the message spool, depending on the size of the stored messages.

1.6 Software Revision

This manual details all the functions available in the Aspen equipment SECS II SLE GEM software revision S9.09g9h which is compatible with SLE software version 9.09, Rev. G9H.

2.0 Supported SECS II Message Summary

S/F	Description	H ↔ E
SxF0	Abort Transaction	→
S1F1	Are You There Request	↔
S1F2	On Line Data	↔
S1F3	Selected Equipment Status Report	→
S1F4	Selected Equipment Status Data	←
S1F9	Material Transfer Status Request	→
S1F10	Material Transfer Status Data	←
S1F11	Status Variable Namelist Request	→
S1F12	Status Variable Namelist Reply	←
S1F13	Establish Communication Request	↔
S1F14	Establish Communication Data	↔
S1F15	Request OFF-LINE	→
S1F16	OFF-LINE Acknowledge	←
S1F17	Request ON-LINE	→
S1F18	ON-LINE Acknowledge	←
S2F13	Equipment Constant Request	→
S2F14	Equipment Constant Data	←
S2F15	New Equipment Constant Send	→
S2F16	New Equipment Constant Acknowledge	←
S2F17	Date and Time Request	↔
S2F18	Date and Time Data	↔
S2F21	Remote Command Send	→
S2F22	Remote Command Acknowledge	←
S2F23	Trace Initialize Send	→
S2F24	Trace Initialize Acknowledge	←
S2F25	Loopback Diagnostic Request	→
S2F26	Loopback Diagnostic Data	←
S2F27	Initiate Processing Request	→

Supported SECS II Message Summary

S/F	Description	H ↔ E
S2F28	Initiate Processing Acknowledge	←
S2F29	Equipment Constant Namelist Request	→
S2F30	Equipment Constant Namelist	←
S2F31	Date and Time Set Request	→
S2F32	Date and Time Set Acknowledge	←
S2F33	Define Report	→
S2F34	Define Report Acknowledge	←
S2F35	Link Event Report	→
S2F36	Link Event Report Acknowledge	←
S2F37	Enable/Disable Event Report	→
S2F38	Enable/Disable Event Report Acknowledge	←
S2F39	Multi-block Inquire	→
S2F40	Multi-block Grant	←
S2F41	Host Command Send	→
S2F42	Host Command Acknowledge	←
S2F43	Reset Spooling Streams and Functions	→
S2F44	Reset Spooling Streams and Functions Acknowledge	←
S2F45	Define Variable Limit Attributes	→
S2F46	Variable Limit Attribute Acknowledge	←
S2F47	Variable Limit Attribute Request	→
S2F48	Variable Limit Attributes Send	←
S3F11	Material ID Request	←
S3F12	Material ID Request Acknowledge	→
S3F13	Material ID Send	→
S3F14	Material ID Acknowledge	←
S4F1	Ready to Send Material	↔
S4F2	Ready to Send Acknowledge	↔
S4F3	Send Material	↔

Supported SECS II Message Summary

S/F	Description	H ↔E
S4F5	Handshake Complete	↔
S4F7	Not Ready to Send	↔
S4F9	Stuck in Send	←
S4F11	Stuck in Receiver	←
S4F13	Send Incomplete Timeout	←
S4F15	Material Received	←
S4F17	Request to Receive Material	↔
S4F18	Request to Receive Material Acknowledge	↔
S5F1	Alarm Report Send	←
S5F2	Alarm Report Acknowledge	→
S5F3	Enable/Disable Alarm Send	→
S5F4	Enable/Disable Alarm Acknowledge	←
S5F5	List Alarm Request	→
S5F6	Alarm Data	←
S5F7	List Enabled Alarm Request	→
S5F8	List Enabled Alarm	←
S6F1	Trace Data Send	←
S6F2	Trace Data Acknowledge	→
S6F3	Discrete Variable Data Send	←
S6F4	Discrete Variable Data Acknowledge	→
S6F5	Multi-block Data Send Inquire	←
S6F6	Multi-block Grant	→
S6F9	Formatted Variable Send	←
S6F10	Formatted Variable Acknowledge	→
S6F11	Event Report Send	←
S6F12	Event Report Acknowledge	→
S6F13	Annotated Event Report Send	←
S6F14	Annotated Event Report Acknowledge	→

Supported SECS II Message Summary

S/F	Description	H ↔ E
S6F15	Event Report Request	→
S6F16	Event Report Data	←
S6F17	Annotated Event Report Request	→
S6F18	Annotated Event Report Data	←
S6F19	Individual Report Request	→
S6F20	Individual Report Data	←
S6F21	Annotated Individual Report Request	→
S6F22	Annotated Individual Report Data	←
S6F23	Request Spooled Data	→
S6F24	Request Spooled Data Acknowledge	←
S7F1	Process Program Load Inquire	→
S7F2	Process Program Load Grant	←
S7F3	Process Program Send	→
S7F4	Process Program Acknowledge	←
S7F5	Process Program Request	→
S7F6	Process Program Data	←
S7F7	Process Program ID Request	←
S7F8	Process Program ID Data	→
S7F17	Delete Process Program Send	→
S7F18	Delete Process Program Acknowledge	←
S7F19	Current EPPID Request	→
S7F20	Current EPPID Data	←
S7F23	Formatted Process Program Send	→
S7F24	Formatted Process Program Acknowledge	←
S7F25	Formatted Process Program Request	→
S7F26	Formatted Process Program Data	←
S7F27	Process Program Verification Send	→
S7F28	Process Program Verification Acknowledge	←

Supported SECS II Message Summary

S/F	Description	H ↔E
S7F65	Route Upload Request	→
S7F66	Route Upload	←
S7F67	Route Download	→
S7F68	Route Download Acknowledge	←
S7F71	Non-Route Process Program Load Inquire	→
S7F72	Non-Route Process Program Load Grant	←
S7F73	Non-Route Formatted Process Program Send	→
S7F74	Non-Route Formatted Process Program Acknowledge	←
S7F75	Non-Route Formatted Process Program Request	→
S7F76	Non-Route Formatted Process Program Data	←
S9F1	Unrecognized Device ID	←
S9F3	Unrecognized Stream Type	←
S9F5	Unrecognized Function Type	←
S9F7	Illegal Data	←
S9F9	Transaction Timer Timeout	←
S9F11	Data Too Long	←
S9F13	Conversation Timeout	←
S10F1	Terminal Request	←
S10F2	Terminal Request Acknowledge	→
S10F3	Terminal Display Single	→
S10F4	Terminal Display Single Acknowledge	←

3.0 Supported SECS II Messages

3.1 SxF0

SxF0 Abort Transaction **S,H→E**

If the Aspen equipment receives a function zero message, it will drop the aborted spooled message.

3.2 S1Fx

S1F1 Are You There Request (R) **S,H↔E, reply**

Establishes if the equipment is online.

Structure:

Header only

S1F2 On Line Data (D) **S,H↔E**

Data signifying that the equipment is alive.

Structure:

L,2

1. <MDLN> (ASCII)
2. <SOFTREV> (ASCII)

Exceptions:

1. The host sends a zero length list to Aspen.
2. If AS1F2 is included with the SECS protocol, the SIB will reply with a single-byte binary message.

Note SOFTREV is the SECS II module's software revision, not the Aspen module.

S1F3 Selected Equipment Status Request (SSR) **S,H→E, reply**

Request for the equipment to report selected status variable IDs. The SVID's numbers are the same as the VID's shown in Appendix D.

Structure:

L,n

1. <SVID1> (2 byte unsigned)
- :
- :
- n. <SVIDn>

Exception:

A zero length list (n = 0) means report all SVIDs. Aspen

Note The SLE software cannot support reporting all SVIDs because the size of the message will exceed the buffer storage in the SECS II card. Send for the SVIDs in groups of 100. There are over 250 SVIDs.

S1F4 Selected Equipment Status Data (SSD)**M,H←E**

Aspen reports the value of each SVID requested in the order requested.

Structure:

```
L,n
  1. <SV1>      (variable data type)
  :
  :
  n. <SVn>
```

Exceptions:

If n = 0, no response can be made. A zero length return for SVIDi means that SVIDi does not exist.

S1F9 Material Transfer Status Request (TSR)**S,H→E, reply**

Host requests a status report of the material transfer ports. The Aspen is equipped with two ports that handle both the input and output material handling operations.

Structure:

Header Only.

S1F10 Material Transfer Status Data (TSD)**S,H←E**

Aspen reports to the host the transfer status of its two material ports.

Structure:

```
L,2
  1. <TSIP1, TSIP2> (1 byte binary)
  2. <TSOP1, TSOP2> (1 byte binary)
```

TSIP:

```
  1 = Empty State.
  2 = Schedule State.
  3 = Track on State.
  4 = Stuck in Receiver State.
  5 = Full State.
```

TSOP:

```
  1 = Empty State.
  2 = Scheduled State.
  3 = Track on State.
  4 = Stuck in Sender State.
  5 = Full State.
```

S1F11 Status Variable Namelist (SVNR)**S,H→E, reply**

A request to Aspen to identify certain status variables.

Structure:

```
L,n
  1. <SVID1>      (2 byte unsigned)
  :
  :
  n. <SVIDn>
```

S1F12 Status Variable Namelist Reply (SVNRR)**M,H←E**

Aspen reports to the host the name and units of the requested Status Variables.

Structure:

- L,n
 - 1. L,3
 - 1. <SVID1> (2 byte unsigned)
 - 2. <SVNAME1> (ASCII)
 - 3. <UNITS> (ASCII)
 - :
 - :
 - n. L,3
 - 1. <SVIDn>
 - 2. <SVNAMEn>
 - 3. <UNITS>

S1F13 Establish Communication Request (ECR)**S,H↔E, reply**

To provide a formal means of initializing communications at a logical application level both on power-up and following a break in communications.

Structure:

- L,2
 - 1. <MDLN> (ASCII)
 - 2. <SOFTREV> (ASCII)

Exception:

The host sends a zero length list to the equipment.

Note Aspen can be switched between the S1F1/S1F13 messages by setting the equipment constant #7 flag. The default is S1F1. [See S2F15 for details.](#)

S1F14 Establish Communications Request Acknowledge (CRA)**S,H↔E**

Accept or deny Establish Communications Request. MDLN and SOFTREV are on-line data and are valid only if COMMACK = 0.

Structure:

- L,2
 - 1. <COMMACK> (1 byte binary)
 - 2. L,2
 - 1. <MDLN> (ASCII)
 - 2. <SOFTREV> (ASCII)

COMMACK:

- 0 = Accepted.
- 1 = Denied, try again.

Exception:

The host sends a zero length list for item 2 to Aspen.

S1F15 Request OFF-LINE (ROFL) S,H→E

The host requests that the equipment transition to the OFF-LINE state.

Structure:

Header only.

S1F16 OFF-LINE Acknowledge S,H←E

Acknowledge or error.

Structure:

0 = OFF-LINE acknowledge.

S1F17 Request ON-LINE (RONL) S,H→E

The host requests that the equipment transition to the ON-LINE state.

Structure:

Header only.

S1F18 ON-LINE Acknowledge (ONLA) S,H←E

Acknowledge or error.

Structure:

0 = ON-LINE accepted.

1 = ON-LINE Not Allowed.

2 = Equipment Already ON-LINE.

3.3 S2Fx**S2F13 Equipment Constant Request (ECR) S,H→E, reply**

Host requests Aspen to send the current <Equipment Constant Values>.

Structure:

```
L,n
  1. <ECID1>      (2 byte unsigned)
  :
  :
  n. <ECIDn>
```

Aspen will also accept <ECID1,...,ECIDn> (1 unsigned integer array) for compatibility with previous implementations.

Exception:

A zero length list will cause Aspen to send all <ECVs>.

S2F14 Equipment Constant Data (ECD)**M,H←E**

Data response to the host in the order requested.

Structure:

```

L,n
  1. <ECV1>      (Equipment Constant data type)
  :
  :
  n. <ECVn>

```

Exceptions:

If n = 0, then no response exists. A zero length ECVi means that ECIDi does not exist.

S2F15 New Equipment Constant Send (ECS)**S,H→E, reply**

Changes to any of the equipment constant variables causes all of the variables in the Equipment Constant disk file to be updated. The equipment constant IDs <Equipment Constant IDs> and <Equipment Constant Values> on each Aspen are shown in Appendix E.

Structure:

```

L,n
  1. L,2
     1. <ECID1>    (2 byte unsigned)
     2. <ECV1>    (ECV variable data type)
  2. L,2
  :
  :
  n. L,2
     1. <ECIDn>
     2. <ECVn>

```

S2F16 New Equipment Constant Acknowledge (ECA)**S,H←E**

Acknowledge or error of the requested changes of the new equipment constant.

Structure:

```
<EAC>      (1 byte binary)
```

```

0 = Accepted.
1 = Denied. At least one constant does not exist.
2 = Denied. Busy.
3 = Denied. Out of Range.

```

S2F17 Date and Time Request (DTR)**S,H↔E, reply**

Useful to check equipment time base to synchronize with the host time base. Aspen will request the Host to send the Date and Time when the communication status changed from Not Communicating to Communicating.

Structure:

Header only.

S2F18 Date and Time Data (DTD)**S,H↔E**

Actual time data.

Structure:

<TIME> (12 byte ASCII “yymmddhhmmss” in case EC13 is set to 0,
16 byte ASCII “yyyymmddhhmmsscc” in case EC13 is set to 1.)

S2F21 Remote Command Send (RCS)**S,H→E, reply**

While in remote mode, the host can command the equipment to pause its operations, continue its operations, or abort its operations. If an abort command is received, the equipment will be switched back to engineering mode and all operation will stop. To restart the equipment for processing, the equipment has to be returned to remote mode and a S2F27 message used to initiate processing.

Structure:

<RCMD> (1 byte unsigned)

1 = Abort.
2 = Continue.
4 = Pause.
6 = Stop (Set inner wafer count to 0).

S2F22 Remote Command Acknowledge (RCA)**S,H←E**

Acknowledge or error.

Structure:

<CMDA> (1 byte binary)

0 = Completed.
2 = Can not perform now. Not in remote mode.
4 = Recipe name not found.

S2F23 Trace Initialize Send (TIS)**S,H→E, reply**

Trace initialize send allows the host to describe a timed data acquisition routine to the Aspen. The host sends the trace identification <TRID>, data sample period <DSPER>, “hhmmss”, total samples <TOTSMP>, and report group size <REPGSZ>. The report group size is defaulted to <1>. The status variables may be selected from Appendix D.

Structure:

L, 5

1. <TRID> (2 byte unsigned)
2. <DSPER> (6 byte ASCII)
3. <TOTSMP> (2 byte unsigned)
4. <REPGSZ> (2 byte unsigned)
5. L,n
 1. <SVID1> (2 byte unsigned)
 2. <SVID2>
 - :
 - :
 - n. <SVIDn>

S2F24 Trace Initialize Acknowledge (TIA)**S,H←E**

Acknowledge or error.

Structure:

<TIAACK> (1 byte binary)

0 = OK.

1 = Too many SVIDs.

2 = No more trace space.

S2F25 Loopback Diagnostic Request (LDR)**S,H→E, reply**

A diagnostic message for checkout of protocol and communication circuits. The ASCII string sent is echoed back.

Structure:

<ABS> (binary array)

S2F26 Loopback Diagnostic Data (LDD)**S,H←E**

The echoed ASCII string.

Structure:

<ABS> (binary array)

S2F27 Initiate Processing Request (IPR)**S,H→E, reply**

The Aspen equipment is required to be in the remote mode before it can accept this command. The host can use this message to start the processing of a single batch of wafers that have been loaded into the outer cassette nests. This single message can be used in place of the S3F11 and S7F7 messages which also provides material id and processing recipe information to the Aspen equipment. It is assumed that a maximum of two cassettes will make up a batch of wafers.

Structure:

L,3

1. <LOC> (1 byte binary)

2. <PPID> (25 byte ASCII)

L,n

1. <MID1> (16 byte ASCII max.)

:

:

n. <MIDn>

LOC =0 = Left Cassette

LOC =1 = Right Cassette

LOC =2 = Both Cassettes

Exceptions:

A zero length PPID indicates no process program is being specified and the equipment is to take the current outer recipe number. A zero length MID list indicates no MID is to be associated with the material to be processed.

S2F28 Initiate Processing Acknowledge (IPA)**S,H←E**

<CMDA> (1 byte binary)

0 = Completed.

2 = Cannot perform now.

4 = Recipe name not found.

S2F29 Equipment Constant Namelist Request (ECNR)**S,H→E, reply**

The host requests Aspen to send the selected equipment constant list.

Structure:

L,n

1. <ECID1> (2 byte unsigned)
- :
- :
- n. <ECIDn>

Exception:

If n = 0, Aspen will reply with the entire equipment constant name list.

S2F30 Equipment Constant Namelist (ECN)**M,H←E**

Data Response.

Structure:

L,n

1. L,6
 1. <ECID> (2 byte unsigned)
 2. <ECNAME> (ASCII)
 3. <ECMIN> (ECID data type)
 4. <ECMAX> (ECID data type)
 5. <ECDEF> (ECID data type)
 6. <UNITS> (ASCII)
- :
- :
- n. L,6

S2F31 Date and Time Set Request (DTS)**S,H→E, reply**

Aspen will set the new date and time based on the message received.

Structure:

<TIME> (12 byte ASCII "yyymmddhhmmss" in case EC13 is set to 0,
16 byte ASCII "yyymmddhhmmsscc" in case EC13 is set to 1)

S2F32 Date and Time Set Acknowledge (DTA)

S,H←E

Acknowledge or error.

Structure:

<TIACK> (1 byte binary)

0 = OK.

1 = Error.

S2F33 Define Report (DR)

M,H→E, reply

The define report message allows the host to describe a group of reports to the Aspen. The reports include <Report ID> and <Variable Data ID>. The variable data is collected and updated by the Aspen throughout its operation. The type of report is determined by the <Equipment Constant ID> No. 1. If it is set to true, it means that an annotated event report (S6F13) will be sent to the host. If it is set to false, an un-annotated (S6F11) event report will be sent. If this is a multi-block message, then the S2F39/S2F40 Inquire/Grant transaction is required.

Structure:

```

L,2
  1. <DATAID> (2 byte unsigned)
  2. L,a
      1. L,2
          1. <RPTID> (2 byte unsigned)
          2. L,b
              1. <VID1> (2 byte unsigned)
              :
              :
              b. <VIDb>
          :
          :
          a. L,2
              1. <RPTID>
              2. L,c
                  1. <VID1>
                  :
                  :
                  c. <VIDc>

```

Exceptions:

1. If a = 0, a list of zero length following <DataID>, will delete all report definitions and associated links.
2. If b = 0, a zero length following <Report ID>, deletes report type <Report ID> and all <Collected Event ID> links to this <Report ID> will be eliminated.

S2F34 Define Report Acknowledge (DRA)**S,H←E**

Acknowledge or error. If an error condition is detected, the entire message is rejected.

Structure:

<DRACK> (1 byte binary)

- 0 = Defined Report Accepted.
- 1 = Insufficient Space for Report.
- 2 = Invalid Report Format.
- 3 = Duplicated Report ID.
- 4 = At least one VID does not exist.
- 5 = At least one RPTID does not exist for deletion.

S2F35 Link Event Report (LER)**M,H→E, reply**

Link Report message allows the host to link Collected Event IDs, <Collected Event ID>, to the various defined reports. Linked event reports will default to disabled. If this message is a multi-block message, the S2F39/S2F40 Inquire/Grant transaction is required.

Structure:

```

L,2
  1. <DATAID> (2 byte unsigned)
  2. L,a
    1. L,2
      1. <CEID1> (2 byte unsigned)
      2. L,b
        1. <RPTID1> (2 byte unsigned)
        :
        :
        b. <RPTIDb>
      :
      :
    a. L,2
      1. <CEIDa>
      2. L,c
        1. <RPTID1>
        :
        :
        c. <RPTIDc>

```

Exception:

- A list of zero length following DATAID deletes all links to all events.
- A list of zero length following CEID deletes all report links to that event.

S2F36 Link Event Report Acknowledge (LERA)**S,H←E**

Acknowledge or error.

Structure:

<LRACK> (1 byte binary)

- 0 = CEID link accepted.
- 1 = Insufficient space.
- 2 = Invalid CEID format.
- 3 = At least one CEID link duplicated.
- 4 = At least one CEID does not exist.
- 5 = At least one RPTID does not exist.
- 6 = Invalid DATAID.

S2F37 Enable/Disable Event Report (EDER)**S,H→E, reply**

Message allows the host to enable or disable reporting for a group of events (Collected Event IDs) by setting Collected Event Enable/Disable to true for enabling or false for disabling.

Structure:

- L,2
 - 1. <CEED> (1 byte boolean)
 - 2. L,n
 - 1. <CEID1> (2 byte unsigned)
 - :
 - :
 - n. <CEIDn>

Exception:

A list of zero length following <CEED> means all CEIDs.

S2F38 Enable/Disable Event Report Acknowledge (EERA)**S,H←E**

Acknowledge or error.

Structure:

<LRACK> (1 byte binary)

- 0 = CEED accepted.
- 1 = At least one CEID not found.
- 2 = Invalid format.

S2F39 Multi-Block Inquire (DMI)**S,H→E, reply**

If an S2F33 or S2F35 message is more than one block, this transaction must precede the message.

Structure:

- L,2
 - 1. <DATAID> (2 byte unsigned)
 - 2. <DATALENGTH> (2 byte integer)

S2F40 Multi-Block Grant (DMBG)**S,H←E**

Grant permission to send multi-block message.

Structure:

<GRANT> (1 byte binary)

- 0 = Permission granted.
- 1 = Busy, try again.
- 2 = No space.
- 3 = Duplicate name.

S2F41 Host Command Send (HCS)**S,H→E, reply**

The Host requests Aspen to perform the specified remote command with its associated parameters in Remote Mode. The remote commands on each Aspen system are shown in Appendix E.

Structure:

L, 2

1. <RCMD> (ASCII e.g. TOP)
2. L, n (n = # of parameters)
 1. L, 2
 1. <CPNAME> (ASCII e.g. WAFER)
 2. <CPVAL> (1 byte binary, 2 byte integer/ ASCII)
 - :
 - n.

S2F42 Host Command Acknowledge (HCA)**S,H ←E**

Acknowledge Host command or error. If the command is not accepted due to one or more invalid parameters, then a list of invalid parameters will be returned containing the parameter name and reason for being invalid.

Structure:

L,2

1. <HCAACK> (binary)
2. L,n (n = # of invalid parameters)
 1. L, 2
 1. <CPNAME> (ASCII)
 2. <CPACK> (binary)
 - :
 - n.

where HCAACK:

- 0 = Acknowledge, command has been performed.
- 1 = Command does not exist.
- 2 = Cannot perform now.
- 3 = At least one parameter is invalid.
- 4 = Acknowledge, command will be performed and completion of the command will be reported by event.
- 5 = Deny, the same command is already accepted.

CPACK:

- 1 = Parameter Name does not exist.
- 2 = Illegal Value specified for CPVAL.
- 3 = Illegal Format specified for CPVAL.

Exception:

If n = 0, a zero length list indicates no invalid parameters.

S2F43 Reset Spooling Streams and Functions**S,H→E, reply**

This message allows the host to select specific streams and functions to be spooled whenever spooling is active. Alarm reporting (S5F1, S5F73) will not be spooled and will be sent to the host immediately. The following are the accepted streams and functions:

Streams	Functions
3	11
4	1, 17
6	1, 3, 11, 13
7	7

Structure:

```

L,m
  1. L,2
    1. <STRID>      (1 byte unsigned)
    2. L,n
      1. <FCNID1>   (1 byte unsigned)
      :
      n. <FCNIDn>
  m.L,2

```

Exceptions:

1. A zero length list, m = 0, turns off spooling for all streams and functions.
2. A zero length list, n = 0, turns on all functions for the associated stream. A defined list of functions for a stream in this message will replace any previously selected function.

S2F44 Reset Spooling Acknowledge (RSA)**M,H←E**

Acknowledge or error. If an error condition is detected, the entire message is rejected.

Structure:

- L,2
 - 1. <RSACK> (1 byte binary)
 - 2. L,m (m = # of invalid streams or functions)
 - 1. L,3
 - 1. <STRID> (1 byte unsigned)
 - 2. <STRACK1> (1 byte binary)
 - 3. L,n
 - 1. <FCNID> (1 byte unsigned)
 - :

RSACK:

- 0 = Acknowledge, spooling setup accepted.
- 1 = Spooling setup rejected.

STRACK:

- 1 = Spooling not allowed for stream.
- 2 = Stream unknown.
- 3 = Unknown function specified for this stream.
- 4 = Secondary function specified for this stream.

Exception:

If RSACK = 0, a zero length list, m = 0 indicates no invalid stream or functions.

S2F45 Define Variable Limit Attributes (DVLA)**M,H→E, reply**

Allows the host to define or modify an existing equipment variable limit definition. Each limit defined will overwrite that limit's previous definition. LIMITID should be a continuous number starting from 1 to 10.

The processing VID variables that are supported are:

- #11 First Chamber RF Power
- #13 First Chamber Process Pressure
- #14 First Chamber Gas 1
- #15 First Chamber Gas 2
- #16 First Chamber Gas 3
- #307 First Chamber Gas 4
- #308 First Chamber Gas 5
- #309 First Chamber Gas 6
- #310 First Chamber Gas 7
- #311 First Chamber Gas 8
- #17 First Chamber Temperature
- #61 Second Chamber RF Power
- #63 Second Chamber Process Pressure
- #64 Second Chamber Gas 1
- #65 Second Chamber Gas 2
- #66 Second Chamber Gas 3
- #407 Second Chamber Gas 4
- #408 Second Chamber Gas 5
- #409 Second Chamber Gas 6
- #410 Second Chamber Gas 7
- #411 Second Chamber Gas 8
- #67 Second Chamber Temperature

Structure:

- L,2
 - 1. <DATAID> (2 byte unsigned)
 - 2. L,m (m = # of variables in this definition)
 - 1. L,2
 - 1. <VID> (2 byte unsigned)
 - 2. L,n (n = # of limits for VID)
 - 1. L,2
 - 1. <LIMITID1> (1 byte binary)
 - 2. L,p
 - 1. <UPPER BOUND> (VID type)
 - 2. <LOWER BOUND> (VID type)
 - :
 - n. L,2
 - 1. <LIMITIDn>
 - 2. L,p
 - 1. <UPPER BOUND>
 - 2. <LOWER BOUND>
- m.L,2
 - 1. <VIDm>

Exceptions:

1. m = 0 sets all limits values for all monitored VIDs to “undefined”.
2. n = 0 sets all limit values for that VID to “undefined”.
3. A zero length list, p = 0, sets that limit to “undefined”.

S2F46 Variable Limit Attribute Acknowledge (VLAA)**M,H←E**

Acknowledge definition of variable limit attributes or error. If DVLA is not accepted due to one or more invalid parameters, then a list of invalid parameters will be returned containing the variable limit attribute and reason for being invalid. If an error condition is detected, the entire message is rejected.

Structure:

- L,2
 - 1. <VLAACK> (1 byte binary)
 - 2. L,m (m = number of invalid parameters).
 - 1. L,3
 - 1. <VID> (2 byte unsigned)
 - 2. <LVACK> (1 byte binary)
 - 3. L,n {n = 0 or 2}
 - 1. <LIMITID1> (1 byte binary)
 - 2. <LIMITACK> (1 byte binary)

VLAACK:

- 0 = Acknowledge, command will be performed.
- 1 = Limit attribute definition error.
- 2 = Cannot perform now.

LVACK: Reason of error

- 1 = Variable does not exist.
- 2 = Variable has no limits capability.
- 3 = Variable repeated in message.
- 4 = Limit value error as described in LIMITACK.

LIMITID: First limit in error for VID.

LIMITACK: Reason of error for LIMITID.

- 1 = LIMITID does not exist.
- 2 = UPPERDB > LIMITMAX.
- 3 = LOWERDB < LIMITMIN.
- 4 = UPPERDB < LOWERDB.
- 5 = Illegal format specified for UPPERDB or LOWERDB.
- 7 = Duplicate limit definition for this variable.

Exceptions:

- 1. A zero length list, m = 0, indicates no invalid variable attributes were found.
- 2. A zero length list, n = 0, indicates that there were no invalid limit values.

S2F47 Variable Limit Attribute Request (VLAR)

S,H→E, reply

This message allows the host to query the equipment for current variable limit attribute definitions.

Structure:

- L,m (m = #VIDs in this request)
- 1. <VID1> (2 byte unsigned)
 - :
 - :
 - m.<VIDm>

Exception:

A zero length list, m = 0, requests a list of all VID values that can have variable limit attributes.

S2F48 Variable Limit Attributes Send (VLAS)

M,H←E

Equipment sends values of requested variable limit attribute definitions in the order requested.

Structure:

- L,m (m = #VIDs in this request)
- 1. L,2
 - 1. <VID> (2 byte unsigned)
 - 2. L, p {p = 0,4}
 - 1. <UNITS1> (ASCII)
 - 2. <LIMITMIN1> (VID data type)
 - 3. <LIMITMAX1> (VID data type)
 - 4. L,n (n = # of limits for VID)
 - 1. L,3
 - 1. <LIMITID1> (1 byte binary)
 - 2. <UPPER BOUND> (VID type)
 - 3. <LOWER BOUND> (VID type)
 - :
 - n. L,3
 - 1. <LIMITIDn>
 - 2. <UPPER BOUND>
 - 3. <LOWER BOUND>
 - :
 - m.L,2
 - 1. <VIDm>

Exceptions:

1. p = 0 indicates that the corresponding VID can have no limit definition.
2. n = 0 means no limits are currently defined for the specified variable.

3.4 S3Fx

S3F11 Material ID Request (MIDR)

S,H←E, reply

While in the remote mode, Aspen requests material id information from the host with the S3F11 function call. If the S2F27 Initiate Processing Request has already been received or is being received, then the Material ID Request will not be needed. The Aspen equipment has two ports with port ID 1 for the left cassette and ID 2 for the right cassette.

Structure:

<PTN> (1 byte binary)

[See Appendix E.](#)

S3F12 Material ID Request Acknowledge (MIRA)

S,H→E

The host acknowledge the request for the Material ID.

Structure:

L,3
 1. <PTN> (1 byte binary)
 2. <MIDRA> (1 byte binary)
 3. <MID> (16 byte ASCII max.)

MIDRA:

- 0 = Acknowledge, MID follows.
- 1 = Acknowledge, will not send MID.
- 2 = Acknowledge, will send MID later in S3F13 message.

Note For all cases except MIDRA = 0, the <MID> will be ignored by the receiver of message S3F12. When MIDRA = 0, a zero length MID indicates that no MID is available.

[See Appendix E.](#)

S3F13 Material ID Send

S,H→E, reply

The host sends the Material ID of material at the specified port. This is the case where a request/acknowledge/send/acknowledge conversation is used for S3F11 and S3F13.

Structure:

L,2
 1. <PTN> (1 byte binary)
 2. <MID> (16 byte ASCII max.)

[See Appendix E.](#)

S3F14 Material ID Acknowledge**S,H←E**

Acknowledge or error.

Structure:

<MIDAC> (1 byte binary)

0 = Accepted.

1 = Invalid port number.

2 = Material is not present at identified port.

>2 = Error.

[See Appendix E.](#)**3.5 S4Fx****S4F1 Ready to Send Material (RSN)****S,H↔E, reply**

The sender advises the receiver that some material is awaiting transfer.

Structure:

L,2

1. <PTN> (1 byte binary)

2. <MID> (16 byte ASCII max.)

Note If a material ID field message length is zero, the material is unknown to the equipment.

[See Appendix E.](#)**S4F2 Ready to Send Acknowledge (RSA)****S,H↔E**

Acknowledge or error.

Structure:

<RSACK> (1 byte binary)

0 = OK.

1 = Invalid port.

2 = Port is already occupied.

3 = Port is busy, try again later.

4 = Aspen Equipment is not in remote mode.

[See Appendix E.](#)**S4F3 Send Material (SMN)****S,H↔E**

The receiver advises the sender that it is ready to receive material.

Structure:

L,2

1. <PTN> (1 byte binary)

2. <MID> (16 byte ASCII max.)

[See Appendix E.](#)

S4F5 Handshake Complete (HCN)**S,H↔E**

Aspen advises sender that material has been received or the host advises Aspen that material has been transferred. The sender may now stop its transfer mechanism.

Structure:

- L,2
- 1. <PTN> (1 byte binary)
- 2. <MID> (16 byte ASCII max.)

[See Appendix E.](#)

S4F7 Not Ready to Send (ABN)**S,H↔E**

Sender advises receiver that no material is being sent.

Structure:

- L,2
- 1. <PTN> (1 byte binary)
- 2. <MID> (16 byte ASCII max.)

[See Appendix E.](#)

S4F9 Stuck in Sender (SSN)**S,H←E**

Time between the receipt of the Send Material (SMN) and material leaving Aspen cassette nests exceeded the T1 time-out.

Structure:

- L,2
- 1. <PTN> (1 byte binary)
- 2. <MID> (16 byte ASCII max.)

[See Appendix E.](#)

S4F11 Stuck in Receiver (SRN)**S,H←E**

Time between Send Material (SMN) and the detection of the material at the Aspen cassette nests exceeded T2 time-out.

Structure:

- L,2
- 1. <PTN> (1 byte binary)
- 2. <MID> (16 byte ASCII max.)

[See Appendix E.](#)

S4F13 Send Incomplete Time-Out (SIN)**S,H←E**

The time between the receipt of the Send Material (SMN) and the receipt of Handshake Complete(HCN) exceeded T3 time-out.

Structure:

- L,2
1. <PTN> (1 byte binary)
 2. <MID> (16 byte ASCII max.)

[See Appendix E.](#)

S4F15 Material Received (MRN)**S,H←E**

Aspen sends Material Received message to the host.

Structure:

- L,2
1. <PTN> (1 byte binary)
 2. <MID> (16 byte ASCII max.)

[See Appendix E.](#)

S4F17 Request to Receive Material (RTR)**S,H↔E, reply**

In the remote control mode, the host and the Aspen equipment use this command to initiate a conversation to transfer the material to the specified port.

Structure:

- L,2
1. <PTN> (1 byte binary)
 2. <MID> (16 byte ASCII max.)

Note A zero length MID means equipment doesn't know MID.

S4F18 Request to Receive Acknowledge (RRA)**S,H↔E**

Acknowledge or error.

Structure:

<RRACK> (1 byte binary)

0 = Acknowledge.

1 = Error.

[See Appendix E.](#)

3.6 S5Fx**S5F1 Alarm Report Send (ARS)****S,H←E, reply**

When an enabled alarm occurs, Aspen will send the alarm to the host. Use S5F3 to enable the selected alarms.

Structure:

- L,3
1. <ALCD> (1 byte binary)
 2. <ALID> (2 byte unsigned)
 3. <ALTX> (ASCII)

ALCD:

- bit 7 set = Alarm occurs.
- bit 7 clear = Alarm cleared.

S5F2 Alarm Report Acknowledge (ARA)**S,H→E**

Acknowledge or error.

Structure:

- <ACKC5> (1 byte binary)

- 0 = Accepted.
- >0 = Error, not accepted.

S5F3 Enable/Disable Alarm Send (EAS)**S,H→E, reply**

The arrival of this message may change the state of the enable alarm bit on the Aspen equipment. The enable bit determines if the alarm will be sent to the host when such an alarm condition changes. The occurrence of an alarm will not be spooled by the Aspen system. The setting or change of alarm bits will be stored on the hard disk and will be retrieved on power-up.

Structure:

- L,2
1. <ALED> (1 byte binary)
 2. <ALID> (2 byte unsigned)

ALED:

- Bit 8 = 0 means disable alarm.
- Bit 8 = 1 means enable alarm.

ALID:

- 1 - 10 = Valid Alarm ID.
- 0 = enable or disable all alarms depending on ALED.

S5F4 Enable/Disable Acknowledge (EAA)**S,H←E**

Acknowledge or error.

Structure:

<ACKC5> (1 byte binary)

0 = Accepted.

>0 = Error, not accepted.

S5F5 List Alarms Request (LAR)**S,H→E, reply**

This message requests the Aspen equipment to send a list of selected alarms.

Structure:

<ALID1,.....,ALIDn> (2 byte unsigned array)

Exception:

A zero length item means send all alarms regardless of the state of ALED.

S5F6 List Alarm Data (LAD)**M,H←E**

This message contains the alarm data known to the equipment.

Structure:

L,m

1. L,3

1. <ALCD1> (1 byte binary)

2. <ALID1> (2 byte unsigned)

3. <ALTX1> (ASCII)

:

:

m.L,3

1. <ALCDm>

2. <ALIDm>

3. <ALTXm>

Exception:

If m = 0, no response can be made. A zero length returned for ALCDi or ALTXi means that value does not exist.

S5F7 List Enabled Alarm Request (LEAR)**S,H→E, reply**

List alarms which are enabled.

Structure:

Header only.

S5F8 List Enabled Alarm Data (LEAD)**M,H←E**

This message is similar to S5F6 except that it lists only alarms which are enabled.

Structure:

Same as S5F6.

3.7 S6Fx

S6F1 Trace Data Send (TDS)**S,H←E, reply**

When a time-out has occurred on a set trace timer, Aspen will send the identified defined trace to the host.

Structure:

- L,4
 - 1. <TRID> (2 byte unsigned)
 - 2. <SMPLN> (2 byte unsigned)
 - 3. <STIME> (16 byte ASCII "YYYYMMDDHHMMSSCC")
 - 4. L,n
 - 1. <SV1> (variable data type)
 - :
 - n. <SVn>

Exception:

A zero length STIME means no value is given and that the time is to be derived from SMPLN along with acknowledge of the request.

S6F2 Trace Data Acknowledge (TDA)**S,H→E**

Acknowledge or error.

Structure:

<ACKC6> (1 byte binary)

0 = Accepted.

>0 = Error, not accepted.

S6F3 Discrete Variable Data Send (DVS)**M,H←E, reply**

This report is defined by a report configuration file which uses a filename "CUSTnn.RPT" where nn is the customer ID number. The customer number is set by using the "edcfg" edit configuration program. The events are enabled and disabled by using the S2F15 message.

The report is sent to the host when an enabled event has occurred and the event report is defined in the report configuration file.

Structure:

- L,3
 - 1. <DATAID> (2 byte unsigned)
 - 2. <CEID> (2 byte unsigned)
 - 3. L,n
 - 1. L,2
 - 1. <DSID1> (2 byte unsigned)
 - 2. L,m
 - 1. L,2
 - 1. <DVNAME1>(ASCII)
 - 2. <DVVAL1> (variable data type)
 - 2. L,2
 - :
 - :

```

                m.L,2
                1. <DVNAMEm>
                2. <DVVALm>
    2. L,2
    :
    :
    n. L,2
        1. <DSIDn>
        2. etc.

```

S6F4 Discrete Variable Data Acknowledge (DVA)**S,H→E**

Acknowledge or error.

Structure:

<ACKC6> (1 byte binary)

0 = Accepted.

>0 = Error, not accepted.

S6F5 Multi-Block Data Send Inquire (MBI)**S,H←E, reply**

The Aspen equipment will send this inquire message to the host if the size of the event data to be sent is larger than one (244 byte) message block.

Structure:

```

    L,2
    1. <DATAID> (2 byte unsigned)
    2. <DATALENGTH> (2 byte integer)

```

S6F6 Multi-Block Grant (MBG)**S,H→E**

Grant permission to send.

Structure:

<GRANT6> (1 byte binary)

0 = Permission granted.

1 = Busy, try again.

2 = Not interested.

>2 = Other errors.

S6F9 Formatted Variable Send (FVS)**M,H←E, reply**

Same as S6F3 except the DVNAMEs are supplied from a predefined form that is known to the host. If S6F9 is multi-block, it must be preceded by the S6F5/S6F6 Inquire/Grant transaction.

Structure:

- ```

L,4
 1. <PFCD> (2 byte unsigned)
 2. <DATAID> (2 byte unsigned)
 3. <CEID> (2 byte unsigned)
 4. L,n
 1. L,2
 1. <DSID1> (2 byte unsigned)
 2. L,m
 1. <DVVAL1> (variable data type)
 :
 m.<DVVALm>
 2. L,2
 :
 :
 n. L,2
 1. <DSIDn>
 2. etc.

```

**S6F10 Formatted Variable Acknowledge (FVA)****S,H→E**

Acknowledge or error.

Structure:

- ```

<ACKC6>      (1 byte binary)

```

0 = Accepted.

>0 = Error, not accepted.

S6F11 Event Report Send (ERS)**M,H←E, reply**

This message with the <Variable Data> is sent to the host any time a linked, enabled <Collected Event ID> has occurred. If the message is a multi-block message, then a S6F5/S6F6 Inquire/Grant transaction will first be sent. In order to have this un-annotated report sent, the Equipment Constant number one must be set to false.

Structure:

- ```

L,3
 1. <DATAID> (2 byte unsigned)
 2. <CEID> (2 byte unsigned)
 3. L,a
 1. L,2
 1. <RPTID> (2 byte unsigned)
 2. L,b
 1. <V1> (variable data type)
 :
 :
 b. <Vb>
 :
 :

```

- a. L,2
  - 1. <RPTIDa>
  - 2. L,c
    - 1. <V1>
    - :
    - :
    - c. <Vc>

## Exceptions:

If there are no reports linked to the event, a 'null' report is assumed. A zero length list for # of reports means there are no reports linked to the given CEID.

**S6F12 Event Report Acknowledge (ERA)****S,H→E**

Acknowledge or error.

## Structure:

<ACKC6> (1 byte binary)

0 = Accepted.

>0 = Error, not accepted.

**S6F13 Annotated Event Report Send (AERS)****S,H←E, reply**

This message is the same as S6F11 except that the <Variable IDs> are sent with the data. If this message is a multi-block message, a S6F5/S6F6 Inquire/Grant transaction will first be sent.

## Structure:

- L,3
  - 1. <DATAID> (2 byte unsigned)
  - 2. <CEID> (2 byte unsigned)
  - 3. L,a
    - 1. L,2
      - 1. <RPTID1> (2 byte unsigned)
      - 2. L,b
        - 1. L,2
          - 1. <VID1> (2 byte unsigned)
          - 2. <V1> (variable data type)
          - :
          - :
        - b. L,2
          - 1. <VIDb>
          - 2. <Vb>
    - :
    - :
    - a. L,2
      - 1. <RPTIDa>
      - 2. L,c
        - 1. L,2
          - 1. <VID1>
          - 2. <V1>
          - :
          - :

- c. L,2
1. <VIDc>
  2. <Vc>

Exceptions:

If there are no reports linked to the event, a 'null' report is assumed. A zero length list for # of reports means there are no reports linked to the given CEID.

#### **S6F14 Annotated Event Report Acknowledge (ERA)**

**S,H→E**

Acknowledge or error.

Structure:

<ACKC6> (1 byte binary)

0 = Accepted.

>0 = Error, not accepted.

#### **S6F15 Event Report Request (ERR)**

**S,H→E, reply**

The host demands a given report group from Aspen.

Structure:

<CEID> (2 byte unsigned)

#### **S6F16 Event Report Data (ERD)**

**M,H←E**

Aspen sends reports linked to a given CEID to host.

Structure:

Identical to structure of S6F11.

Exception:

A zero length item means there are no reports linked to the given CEID.

#### **S6F17 Annotated Event Report Request (AERR)**

**S,H→E, reply**

The host requests annotated reports from Aspen by a given CEID.

Structure:

<CEID> (2 byte unsigned)

#### **S6F18 Annotated Event Report Data (AERD)**

**M,H←E**

Aspen sends annotated reports linked to a given CEID to host.

Structure:

Identical to structure of S6F13.

Exception:

A zero length item means there are no reports linked to the given CEID.



**S6F19 Individual Report Request (IRR)****S,H→E, reply**

The host requests a defined report from the Aspen Equipment.

Structure:

<RPTID> (2 byte unsigned)

**S6F20 Individual Report Data (IRD)****M,H←E**

Aspen will return an unannotated predefined report.

Structure:

L,n (# of variable data items)  
 1. <V1>  
 :  
 :  
 n. <Vn>

Exceptions:

A zero length list means the RPTID is not defined.

**S6F21 Annotated Individual Report Request (IRR)****S,H→E, reply**

The host requests an annotated defined report from the Aspen Equipment.

Structure:

<RPTID> (2 byte unsigned)

**S6F22 Individual Report Data (IRD)****M,H←E**

Aspen will return an annotated predefined report.

Structure:

L,n (# of variable data items);  
 1. L,2  
     1. <VID1> (2 byte unsigned)  
     2. <V1> (variable data type)  
 :  
 :  
 n. L,2  
     1. <VIDn>  
     2. <Vn>

Exceptions:

A zero length list means the RPTID is not defined.

**S6F23 Request Spooled Data (RSD)****S,H→E, reply**

This message allows the host to request transmission or deletion of the spooled data that the Aspen equipment has to send.

Structure:

<RSDC> (1 byte unsigned)

0 = Transmit Spooled Messages.

1 = Purge Spooled Messages.

**S6F24 Request Spooled Data Acknowledgment Send****S,H←E**

Acknowledge or error.

Structure:

<RSDA> (1 byte binary)

0 = Accepted.

1 = Denied, busy, try later.

2 = Denied, spool data does not exist.

**3.8 S7Fx****S7F1 Process Program Load Inquire (PPI)****S,H→E, reply**

This message is used to initiate a recipe program transfer between the host and the Aspen equipment.

Structure.

L,2

1. <PPID> (25 byte ASCII)

2. <LENGTH> (2 byte unsigned)

**S7F2 Process Program Load Grant (PPG)****S,H←E**

This message gives permission for the process recipe program to be loaded.

Structure:

<PPGNT> (1 byte binary)

0 = OK to download recipe file to Aspen.

1 = No space for the recipe file. Must delete a recipe first.

2 = Invalid PPID.

4 = Aspen is busy, try later.

5 = Mismatched Recipe Name.

---

**Note** The recipe is assumed to be returned to the equipment in the same format as it was given to the host.

---

[See Appendix G](#) for program body description.

**S7F3 Process Program Send (PPS)****S,H→E, reply**

The program is sent. If S7F3 is multi-block, it must be preceded by the S7F1/S7F2 Inquire/Grant transaction.

Structure:

- L,2
  1. <PPID> (25 byte ASCII)
  2. <PPBODY> (ASCII)

**S7F4 Process Program Acknowledge (PPA)****S,H←E**

Acknowledge or error.

Structure:

- <ACKC7> (1 byte binary)

- 0 = Accepted.
- 1 = Permission not granted.
- 4 = Process Program ID not found.
- 5 = Mode not supported.
- 6 = Other error.

**S7F5 Process Program Request (PPR)****S,H→E, reply**

This message requests that a process recipe program be uploaded to the host.

Structure:

- <PPID> (25 byte ASCII)

**S7F6 Process Program Data (PPD)****M,H←E**

This message is used to transfer a process program.

Structure:

- L,2
  1. <PPID> (25 byte ASCII)
  2. <PPBODY> (ASCII)

Exception:

- A zero length list means request denied.

**S7F7 Process Program ID Request (PIR)****S,H←E, reply**

This message is used when Aspen is in the remote mode to request a process program for use on the material identified.

Structure:

- <MID> (16 byte ASCII max.)

[See Appendix E.](#)

**S7F8 Process Program ID Data (PID)****S,H→E**

The host transmits a single matrix entry in response to S7F7.

Structure:

- L,2
1. <PPID> (25 byte ASCII)
  2. <MID> (16 byte ASCII max.)

[See Appendix E.](#)

**S7F17 Delete Process Program Send (DPS)****S,H→E, reply**

This message requests that a set of recipe programs be deleted from the Aspen equipment. Aspen accepts a <n> item list of ASCII format <Recipe Program Names>.

Structure:

- L,n
1. <PPID1> (25 byte ASCII)
  - :
  - :
  - n. <PPIDn>

---

**Note** If n = 0, Aspen will ignore this message and response with permission not granted.

---

**S7F18 Delete Process Program Acknowledge (DPA)****S,H←E**

Acknowledge or error.

Structure:

<ACKC7> (1 byte binary)

0 = Accepted.

1 = Permission not granted.

Permission not granted implies that the requested recipe name did not exist.

**S7F19 Current EPPD Request (RER)****S,H→E, reply**

This message is used to request the transmission of the Aspen recipe program directory.

Structure:

Header only.

**S7F20 Current EPPD Data (RED)****S,H←E**

Aspen responds with a list of 99 recipe names.

Structure:

- L,n
1. <PPID1> (25 byte ASCII)
  - :
  - n. <PPIDn>

**S7F23 Formatted Process Program Send (FPS)****M,H→E, reply**

This message allows movement of formatted process programs from host to equipment. If S7F23 is a multi-block, it must be preceded by the S7F1/F2 Inquire/Grant.

Use below structure to download by name or number. Recipe name will not change in tool memory.

Structure:

```

L,4
 1. <PPID> (A25)
 2. <MDLN> (A6)
 3. <SOFTREV> (A6)
 4. L,c
 1. L,2
 1. <CCODE> (U2)
 2. L,p
 1. <PPARM1>
 :
 p. <PPARMp>
 :
 :
 c. L,2

```

---

**Note** The value of c and p depends on the system type. See [Appendix H](#) for the description of c, p, and PPARAMs.

---

**S7F24 Formatted Process Program Acknowledge (FPA)****S,H←E**

Acknowledge or error.

Structure:

```
<ACK7> (B1)
```

0 = Accepted.

1 = Permission not granted.

6 = Invalid recipe.

**S7F25 Formatted Process Program Request (FPR)****S,H→E,reply**

This message is used by the host to request a particular process program from the equipment.

Structure:

```
<PPID> (ASCII 25)
```

**S7F26 Formatted Process Program Data (FPD)****M,H←E**

This message is used to transfer a process program in response to a request for the PPID.

Structure:

- ```

L,4
  1. <PPID>      (A25)
  2. <MDLN>      (A6)
  3. <SOFTREV>   (A6)
  4. L,c
      1. L,2
          1. <CCODE> (U2)
          2. L,p
              1. <PPARM1>
              :
              p. <PPARMp>
          :
          :
      c. L,2
  
```

Note The value of c and p depends on the system type. See [Appendix H](#) for the description of c, p, and PPARMs and the difference between Strip and SLE Structure.

Exception:

A zero length list indicates the request was denied.

Note The next four Streams and Functions (S7F65, S7F66, S7F67 and S7F68) are to accommodate the routing function of the SLE software.

S7F65 Route Upload Request (RUR)**S,H→E**

This message requests the tool to send a list of all 99 routes to the host in the format described in S7F66.

Structure:

Header only.

S7F66 Route Upload (RUP)**S,H←E**

Aspen responds to S7F65 with a list of all 99 routes and settings to the host in the format shown below.

Structure:

```

L,99          (1 byte binary)
  L,5          (Route 1)
    <Route Index>(1)  (U2)
    <Type Route>(0-4) (U2)
                                0 = Right Chamber Only
                                1 = Back Chamber Only
                                2 = Parallel
                                3 = Sequence Right Chamber First
                                4 = Sequence Back Chamber First
    <Right Chamber Recipe>      (1-99) (U2)
    <Back Chamber Recipe>      (1-99) (U2)
    <Sequential Cooling Time>   (0-10,000) (U2)
    <Route Name>                (ASCII 40 characters)
  L,5          (Route 2)\

```

Repeat for Routes 2 - 99.

S7F67 Route Download (RDL)**S,H←E**

This message downloads and overwrites a specific route from 1 to 99.

Structure:

```

L,1          (1 byte binary)
  L,5          (Route 1)
    <Route Index>(1)  (U2)
    <Type Route>(0-4) (U2)
                                0 = Right Chamber Only
                                1 = Back Chamber Only
                                2 = Parallel
                                3 = Sequence Right Chamber First
                                4 = Sequence Back Chamber First
    <Right Chamber Recipe>      (1-99) (U2)
    <Back Chamber Recipe>      (1-99) (U2)
    <Sequential Cooling Time>   (0-10,000) (U2)
    <Route Name>                (ASCII 40 characters)

```

S7F68 Route Download Acknowledge (RDA)**S,H←E**

Acknowledge.

Structure:

Header only.

Note The following messages (S7F71 through S7F76) allow uploading and downloading of formatted recipe data by number of recipe (PPID) if the tool is not in routing mode (i.e. Routing is Disabled in the CN page for both inner and outer cassette nests).

Always select the chamber to download to or upload from with S2F41 Remote Command(s) “Back Recipe” or “Right Recipe” before sending the S7F75 Upload or S7F71 Download requests.

Downloads will not change the PPID (recipe name), only the recipe content unless the recipe is currently named “EMPTY RECIPE” and, in that case, will name the recipe “RCP##-FromHost” which can be renamed at the tool in the MN D Menu in Engineering Mode.

S7F71 Non-Route Process Program Load Inquire (NPPI)

S,H→E

This message is used to initiate a recipe program transfer between the host and the Aspen equipment.

Structure:

- L,2
- 1. <PPID> (U2) 1-99
- 2. <LENGTH> (U2)

S7F72 Non-Route Program Load Grant (NPPG)

S,H←E

This message give permission for the process recipe program to be loaded.

Structure:

<PPGNT> (1 byte binary)

- 0 = OK to download recipe file to the Aspen.
- 1 = No space for the recipe file. A recipe must be deleted first.
- 2 = Invalid PPID
- 4= Aspen is busy, try later.
- 5 = Mis-matched recipe name.
- 6 = Other error.
- 7 = Routing not disabled.

Note The recipe is assumed to be returned to the equipment in the same format as it was given to the host.

See [Appendix G](#) for the Program Body Description.

S7F73 Non-Route Formatted Process Program Send (NFPS)**S,H→E**

This message allows movement of formatted process programs from the host to the equipment. If the S7F73 is a multi-block, it must be preceded by the S1F71/F72 Inquire/Grant.

Structure:

```

L,4
  1. <PPID>      (U2)   1-99
  2. <MDLN>      (A6)
  3. <SOFTREV>   (A6)
  4. L,c
      1. L,2
          1. <CCODE>   (U2)
          2. L,p
              1. <PPARM1>
              :
              p. <PPARMp>
          :
          :
      c. L,2
  
```

Note The value of c and p depends on the system type. See [Appendix H](#) for the description of c, p, and PPARAMs.

S7F74 Non-Route Formatted Process Program Acknowledge (NFPA)**S,H←E**

Acknowledge or error.

Structure:

```
<ACK7>      (1 byte binary)
```

```

0 = Accepted.
1 = Permission not granted.
4 = No PPID.
5 = Mode not supported.
6 = Other error.
7 = Routing not disabled.
  
```

S7F75 Non-Route Formatted Process Program Request (NFPR)**S,H→E**

This message is used by the host to request a particular process program from the equipment.

Structure:

```
<PPID>      (U2)   1-99
```

S7F76 Non-Route Formatted Process Program Data (NFPD)**S,H←E**

This message is used to transfer a process program in response to a request for the PPID. Note that the PPID is still returned with the ASCII name.

Structure:

- ```

L,4
 1. <PPID> (A25)
 2. <MDLN> (A6)
 3. <SOFTREV> (A6)
 4. L,c
 1. L,2
 1. <CCODE> (U2)
 2. L,p
 1. <PPARM1>
 :
 p. <PPARMp>
 :
 :
 c. L,2

```

---

**Note** The value of c and p depends on the system type. See [Appendix H](#) for the description of c, p, and PPARMs.

---

Exception:

A zero length list indicates the request was denied.

**3.9 S9Fx****S9F1 Unrecognized Device ID (UDN)****S,H←E**

Structure:

```
<MHEAD> (10 byte binary)
```

**S9F3 Unrecognized Stream Type (USN)****S,H←E**

Structure:

```
<MHEAD> (10 byte binary)
```

**S9F5 Unrecognized Function Type (UFN)****S,H←E**

Structure:

```
<MHEAD> (10 byte binary)
```

**S9F7 Illegal Data (IDN)****S,H←E**

Structure:

```
<MHEAD> (10 byte binary)
```

**S9F9 Transaction Timer Time-Out (TTN) S,H←E**

Structure:  
 <SHEAD> (10 byte binary)

**S9F11 Data Too Long (DLN) S,H←E**

Structure:  
 <MHEAD> (10 byte binary)

**S9F13 Conversation Time-Out (CTN) S,H←E**

Data were expected but none were received within a reasonable length of time. Resources have been cleared.

Structure:  
 L,2  
 1. <MEXP> (ASCII)  
 2. <EDID> (ASCII)

**3.10 S10Fx****S10F1 Terminal Request (TRN) S,H←E**

Aspen can send up to 64 bytes to the Host.

Structure:  
 L,2  
 1. <TID> (1 byte binary)  
 2. <TEXT> (64 byte ASCII max.)  
  
 TID = 0

**S10F2 Terminal Request Acknowledge (TRA) S,H→E**

Acknowledge or error.

Structure:  
 <ACKA10> (1 byte binary)

**S10F3 Terminal Display, Single (VTN) S,H→E**

The host sends data which does not exceed 160 bytes to Aspen to be displayed on line 24 and line 25.

Structure:  
 L,2  
 1. <TID> (1 byte binary)  
 2. <TEXT> (160 byte ASCII max.)  
  
 TID = 0

**S10F4 Terminal Display, Single Acknowledge (VTA)****S,H←E**

Acknowledge or error.

Structure:

&lt;ACKA10&gt; (1 byte binary)

0 = Accepted for display.

1 = Message will not be displayed.

**S10F5 Terminal Display, Multi-Block (VTN)****S,H→E**

The host sends data to Aspen to be displayed on a full screen page.

Structure:

L,2

1. &lt;TID&gt; (1 byte binary)

2. L, n (n = 1 to 19)

1. &lt;TEXT&gt; (80 byte ASCII max.)

:

:

n. &lt;TEXT&gt; (80 byte ASCII max.)

**S10F6 Terminal Display, Multi-Block Acknowledge (VMA)****S,H←E**

Acknowledge or error.

Structure:

&lt;ACKA10&gt; (1 byte binary)

0 = Accepted for display.

1 = Message will not be displayed.



## 4.0 State Diagrams and Transition Tables

### 4.1 Communication State

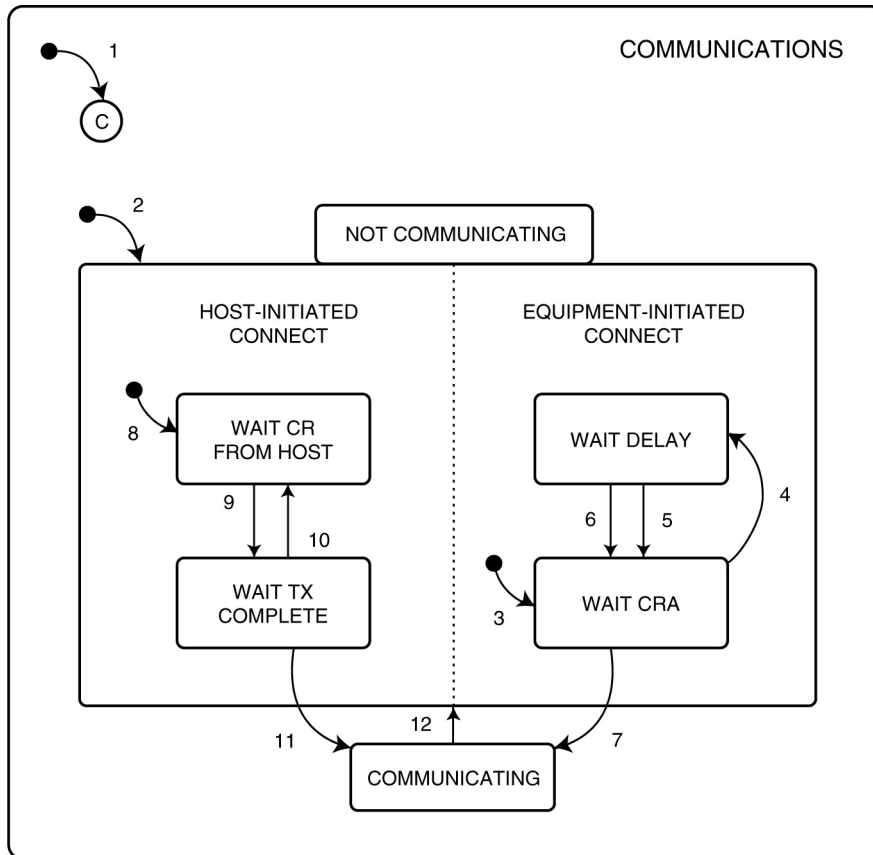

Figure 4-1. Communications State Diagram

Table 4-1: Communications State Transition Table

| #  | Current State                          | Trigger                                    | New State         | Action                                                                | Comments                                                                                                            |
|----|----------------------------------------|--------------------------------------------|-------------------|-----------------------------------------------------------------------|---------------------------------------------------------------------------------------------------------------------|
| 1  | (Entry to COMMUNICATIONS)              | System Initialization                      | System Default    | None.                                                                 | The system default may be set to DISABLED or ENABLED.                                                               |
| 2  | (Entry to ENABLED)                     | Any entry to ENABLED state                 | NOT COMMUNICATING | None.                                                                 | May enter from system initialization to ENABLED or through operator switch to ENABLED.                              |
| 3  | (Entry to EQUIPMENT-INITIATED CONNECT) | Any entry to NOT COMMUNICATING             | WAIT CRA          | Initialize communications. Set CommDelay timer "Expired". Send S1F13. | Begin the attempt to establish communications.                                                                      |
| 4  | WAIT CRA                               | Connection Transaction Failure             | WAIT DELAY        | Initialize CommDelay timer. Dequeue all messages queued to send.      | If appropriate, dequeued messages shall be placed in spool buffer in the order generated. Wait for timer to expire. |
| 5  | WAIT DELAY                             | CommDelay timer expired                    | WAIT CRA          | Discard message. No reply. Set CommDelay timer "Expired". Send S1F13. | Wait for S1F14. May receive S1F13 from Host.                                                                        |
| 6  | WAIT DELAY                             | Received a message other than S1F13.       | WAIT CRA          | Discard message. No reply. Set CommDelay timer "Expired". Send S1F13. | Indicates opportunity to establish communications.                                                                  |
| 7  | WAIT CRA                               | Received expected S1F14 with COMMACK = 0.  | COMMUNICATING     | None.                                                                 | Communications Established.                                                                                         |
| 8  | (Entry to HOST-INITIATED CONNECT)      | (Any entry to NOT COMMUNICATING)           | WAIT CR FROM HOST | None.                                                                 | Wait for S1F13 from Host.                                                                                           |
| 9  | WAIT CR FROM HOST                      | Received S1F13.                            | WAIT TX COMPLETE  | Send S1F14 with COMMACK = 0.                                          | Host seeks to establish communications.                                                                             |
| 10 | WAIT TX COMPLETE                       | S1F14 transmission failed.                 | WAIT CR FROM HOST | None.                                                                 | Communications are established.                                                                                     |
| 11 | WAIT TX COMPLETE                       | S1F14 transmission completed successfully. | COMMUNICATING     | None.                                                                 | Communications are established.                                                                                     |
| 12 | COMMUNICATING                          | Communication failure.                     | NOT COMMUNICATING | Dequeue all messages queued to send.                                  | Dequeued messages may be placed in spool buffer as appropriate.                                                     |

4.2 Control State

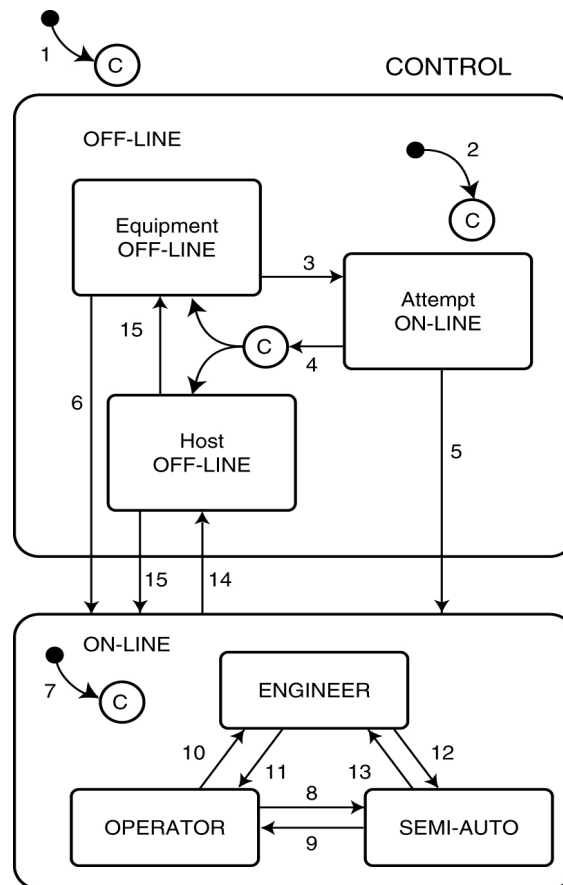

Figure 4-2. Control State Diagram

Table 4-2: Control State Transition Table

| # | Current State      | Trigger                                           | New State                                         | Action | Comments                                                            |
|---|--------------------|---------------------------------------------------|---------------------------------------------------|--------|---------------------------------------------------------------------|
| 1 | (Undefined)        | Entry into CONTROL state (system initialization). | CONTROL (Substate conditional on configuration).  | None.  | Equipment may be configured to default to ON-LINE or OFF-Line.*     |
| 2 | (Undefined)        | Entry into OFF-LINE state.                        | OFF-LINE (Substate conditional on configuration). | None.  | Equipment may be configured to default to any substate of OFF-LINE. |
| 3 | EQUIPMENT OFF-LINE | Operator actuates ON-LINE switch.                 | Attempt ON-LINE.                                  | None.  | Note that an SIF1 is sent whenever ATTEMPT ON-LINE is activated.    |



| #  | Current State   | Trigger                                                     | New State                                                      | Action | Comments                                                                                                                                           |
|----|-----------------|-------------------------------------------------------------|----------------------------------------------------------------|--------|----------------------------------------------------------------------------------------------------------------------------------------------------|
| 4  | Attempt ON-LINE | S1F0                                                        | New state conditional upon configuration.                      | None.  | This may be due to a communication failure, ** reply timeout, or receipt of S1F0. Configuration may be set to EQUIPMENT OFF-LINE or HOST OFF-LINE. |
| 5  | Attempt ON-LINE | Equipment receives expected S1F2 message from the host.     | ON-LINE                                                        | None.  | Host is notified of transition to ON-LINE at transition 7.                                                                                         |
| 6  | ON-LINE         | Operator actuates OFF-LINE switch.                          | EQUIPMENT OFF-LINE                                             | None.  | “Equipment OFF-LINE” event occurs***. Event reply will be discarded while OFF-LINE is active.                                                      |
| 7  | (Undefined)     | Entry to ON-LINE state.                                     | ON-LINE (Substate conditional on REMOTE/LOCAL switch setting.) | None.  | “Control State Local” or “Control State REMOTE” event occurs. Event reported based upon actual ON-LINE substate activated.                         |
| 8  | OPERATOR        | Operator sets control mode to SEMI-AUTO.                    | SEMI-AUTO                                                      | None.  | “Control State SEMI-AUTO” event occurs.                                                                                                            |
| 9  | SEMI-AUTO       | Operator sets control mode to OPERATOR.                     | OPERATOR                                                       | None.  | “Control State OPERATOR” event occurs.                                                                                                             |
| 10 | OPERATOR        | Operator sets control mode to ENGINEER.                     | ENGINEER                                                       | None.  | “Control State ENGINEER” event occurs.                                                                                                             |
| 11 | ENGINEER        | Operator sets control mode to OPERATOR.                     | OPERATOR                                                       | None.  | “Control State OPERATOR” event occurs.                                                                                                             |
| 12 | ENGINEER        | Operator sets control mode to SEMI-AUTO.                    | SEMI-AUTO                                                      | None.  | “Control State SEMI-AUTO” event occurs.                                                                                                            |
| 13 | SEMI-AUTO       | Operator sets control mode to ENGINEER.                     | ENGINEER                                                       | None.  | “Control State ENGINEER” event occurs.                                                                                                             |
| 14 | ON-LINE         | Equipment accepts “Set OFF-LINE” message from host (S1F15). | HOST OFF-LINE                                                  | None.  | “Control State OFF-LINE” event occurs.                                                                                                             |
| 15 | HOST OFF-LINE   | Equipment accepts host request to go ON-LINE (S1F17).       | ON-LINE                                                        | None.  | Host is notified to transition to ON-LINE at transition 7.                                                                                         |
| 16 | HOST OFF-LINE   | Operator actuates OFF-LINE switch.                          | EQUIPMENT OFF-LINE                                             | None.  | Equipment “OFF_LINE” event occurs.                                                                                                                 |

\* The configuration mentioned for transitions 1 and 2 should be a single setting. This would provide the user with a choice of entering EQUIPMENT OFF-LINE, ATTEMPT ON-LINE, HOST OFF-LINE, or ON-LINE states.

\*\* If SECS-I is used, this means the retry limit RTY is exceeded during the attempt to send a message.

\*\*\* Any host-initiated transaction open at the equipment must be completed. This may happen either by sending the appropriate reply to the host prior to sending the event message or by sending an SxF0 message following the event message (i.e. after the transaction).

4.3 Processing State

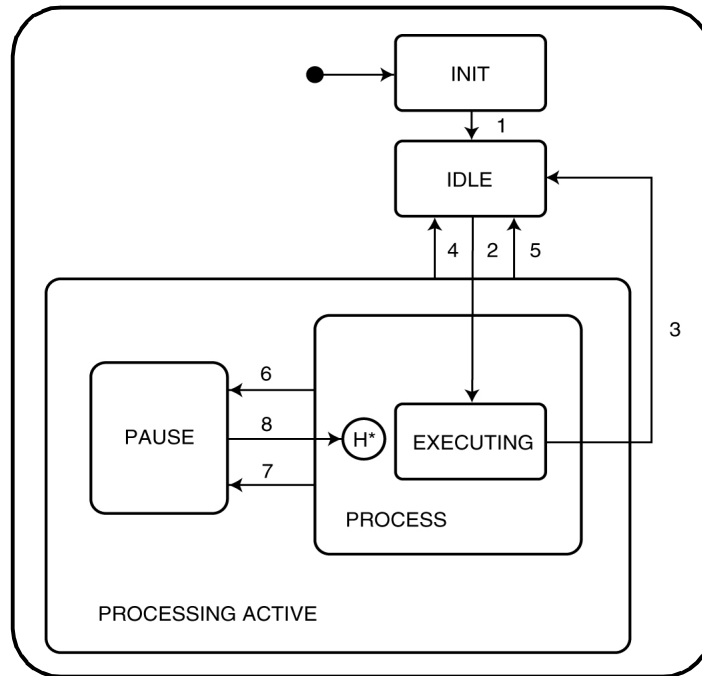

Figure 4-3. Processing State Diagram

Table 4-3: Processing State Transition Table

| # | Current State     | Trigger                                                                        | New State                 | Action                               | Comments                                                          |
|---|-------------------|--------------------------------------------------------------------------------|---------------------------|--------------------------------------|-------------------------------------------------------------------|
| 1 | INIT              | Equipment initialization complete.                                             | IDLE                      | None.                                | None.                                                             |
| 2 | IDLE              | Equipment has received a START command from the host or operator console.      | EXECUTING                 | This activity is equipment-specific. | None.                                                             |
| 3 | EXECUTING         | The processing task has been completed.                                        | IDLE                      | None.                                | None.                                                             |
| 4 | PROCESSING ACTIVE | The equipment has received a STOP command from the host or operator console.   | IDLE                      | None.                                | None.                                                             |
| 5 | PROCESSING ACTIVE | The equipment has received an ABORT command from the host or operator console. | IDLE                      | This activity is equipment-specific. | None.                                                             |
| 6 | PROCESS           | The equipment decides to PAUSE due to a condition such as an alarm.            | PAUSE                     | This activity is equipment-specific. | For this type of problem, an operator assist is usually required. |
| 7 | PROCESS           | The equipment has received a PAUSE command from the host or operator console.  | PAUSE                     | This activity is equipment-specific. | None.                                                             |
| 8 | PAUSE             | The equipment has received a RESUME command from the host or operator console. | Previous PROCESS substate | This activity is equipment-specific. | None.                                                             |

4.4 Limit State

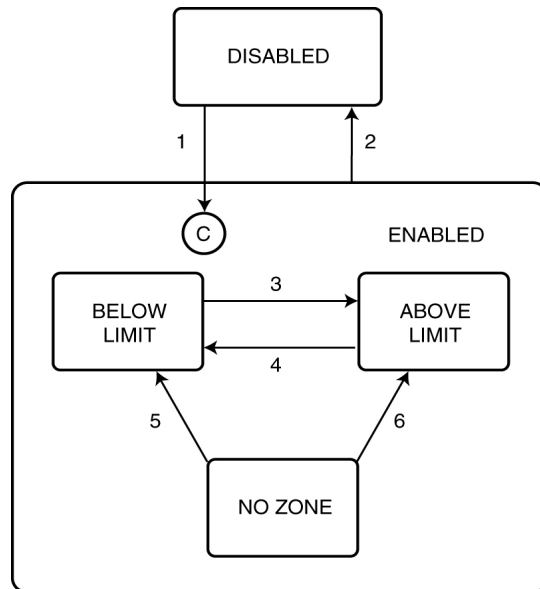

Figure 4-4. Limit State Diagram

Table 4-4: Limit State Transition Table

| # | Current State | Trigger                                       | New State   | Action | Comments                                                                              |
|---|---------------|-----------------------------------------------|-------------|--------|---------------------------------------------------------------------------------------|
| 1 | DISABLED      | Limit attributes defined with S2F45.          | ENABLED     | None.  | The substate of ENABLED is determined by the current value of the monitored variable. |
| 2 | ENABLED       | Limit attributes set to undefined with S2F45. | DISABLED    | None.  | None.                                                                                 |
| 3 | BELOW LIMIT   | Variable increases to be $\geq$ UPPERDB.      | ABOVE LIMIT | None.  | Zone Transition.                                                                      |
| 4 | ABOVE LIMIT   | Variable decreases to be $\leq$ LOWERDB.      | BELOW LIMIT | None.  | Zone Transition.                                                                      |
| 5 | NO ZONE       | Variable decreases to be $\leq$ LOWERDB.      | BELOW LIMIT | None.  | Zone Transition.                                                                      |
| 6 | NO ZONE       | Variable increases to be $\geq$ LOWERDB.      | ABOVE LIMIT | None.  | Zone Transition.                                                                      |

4.5 Alarm State

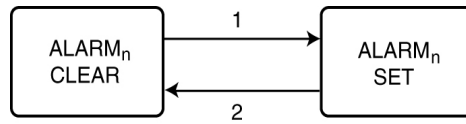

Figure 4-5. Alarm State Diagram

Table 4-5: Alarm State Transition Table

| # | Current State | Trigger                                                    | New State                | Action                                                                                                                                             | Comments                                                                      |
|---|---------------|------------------------------------------------------------|--------------------------|----------------------------------------------------------------------------------------------------------------------------------------------------|-------------------------------------------------------------------------------|
| 1 | ALARMn CLEAR  | Alarm <sub>n</sub> is detected on the equipment.           | ALARM <sub>n</sub> SET   | Initiate local actions (if any) to ensure safety. Update "AlarmSet" and "ALCD <sub>n</sub> " values. Generate and issue alarm message, if enabled. | Inhibited activities require operator or host intervention prior to resuming. |
| 2 | ALARMn SET    | Alarm <sub>n</sub> is no longer detected on the equipment. | ALARM <sub>n</sub> CLEAR | Update "AlarmSet" and "ALCD <sub>n</sub> " values. Generate and issue alarm message, if enabled.                                                   | Inhibited activities require operator or host intervention prior to resuming. |

## Appendix A—Alarm IDs

| Alarm ID No. | Message                        | Description                                                                                             | ALCD |
|--------------|--------------------------------|---------------------------------------------------------------------------------------------------------|------|
| 1            | MACHINE NOT SAFE               | Equipment Safety Error.<br>I/O Electrical control function is in question.                              | 82   |
| 2            | ROBOT FAILED                   | Unrecoverable Error.<br>The robot was unable to complete a motion that it was commanded to execute.     | 85   |
| 3            | CHAMBER PRESSURE FAILED        | Unrecoverable Error.<br>The reactor chamber pressure was unable to reach its assigned pressure.         | 85   |
| 4            | SHUTTLE PRESSURE SYSTEM FAILED | Unrecoverable Error.<br>Shuttle pressure system was not able to complete its requested pressure change. | 85   |
| 5            | SHUTTLE FAILED                 | Unrecoverable Error. The shuttle was unable to complete a motion that it was commanded to perform.      | 85   |
| 6            | RF FAILED                      | Parameter Control Error.<br>RF output is outside of process limits.                                     | 84   |
| 7            | GAS HANDLING ERROR             | Parameter Control Error.<br>Process Gas control system was not properly used.                           | 84   |
| 8            | <gas name>: GAS 1 FAILED       | Parameter Control Error.<br>Process Gas failed to work properly.                                        | 84   |
| 9            | <gas name>: GAS 2 FAILED       | Parameter Control Error.<br>Process Gas failed to work properly.                                        | 84   |
| 10           | <gas name>: GAS 3 FAILED       | Parameter Control Error.<br>Process Gas failed to work properly.                                        | 84   |
| 11           | LEFT CASSETTE UNLOAD ERROR     | Unrecoverable Error. AGV/SMIF left cassette unload fails during transfer.                               | 85   |
| 12           | RIGHT CASSETTE UNLOAD ERROR    | Unrecoverable Error. AGV/SMIF right cassette unload fails during transfer.                              | 85   |
| 13           | LEFT CASSETTE LOAD ERROR       | Unrecoverable Error. AGV/SMIF left cassette load fails during transfer.                                 | 85   |
| 14           | RIGHT CASSETTE LOAD ERROR      | Unrecoverable Error. AGV/SMIF right cassette load fails during transfer.                                | 85   |
| 15           | PIO SIGNAL ERROR               | Unrecoverable Error. AGV PIO signal error during cassette transfer.                                     | 85   |
| 16           | <gas name>: GAS 4 FAILED       | Parameter Control Error.<br>Process Gas failed to work properly.                                        | 84   |
| 17           | <gas name>: GAS 5 FAILED       | Parameter Control Error.<br>Process Gas failed to work properly.                                        | 84   |
| 18           | <gas name>: GAS 6 FAILED       | Parameter Control Error.<br>Process Gas failed to work properly.                                        | 84   |

## Appendix A—Alarm IDs

---

| <b>Alarm ID No.</b> | <b>Message</b>           | <b>Description</b>                                               | <b>ALCD</b> |
|---------------------|--------------------------|------------------------------------------------------------------|-------------|
| 19                  | <gas name>: GAS 7 FAILED | Parameter Control Error.<br>Process Gas failed to work properly. | 84          |
| 20                  | <gas name>: GAS 8 FAILED | Parameter Control Error.<br>Process Gas failed to work properly. | 84          |

## Appendix B—Equipment Constants

| ECID | Description                                                                                                                                                                                                                                     | Units  | Format          | Min. | Max. | Default |
|------|-------------------------------------------------------------------------------------------------------------------------------------------------------------------------------------------------------------------------------------------------|--------|-----------------|------|------|---------|
| 0    | Establish communication timeout. This value sets the time which Aspen will wait before re-attempting to check if the host is back online.                                                                                                       | sec.   | 2 byte unsigned | 1    | 3000 | 60      |
| 1    | Sets the event reporting to be either annotated or not. If set to false, annotation will be excluded. If set to true, annotation will be included with the event reporting.                                                                     |        | 1 byte boolean  | 0    | 1    | 1       |
| 2    | S4F9: T1 stuck in sender timeout.<br><b>Note:</b> The default value for T1 is taken from the recommended default value in the SEMI specification manual.                                                                                        | sec.   | 2 byte unsigned | 1    | 3000 | 10      |
| 3    | S4F11: T2 stuck in receiver timeout.<br><b>Note:</b> The default value for T2 is taken from the recommended default value in the SEMI specification manual.                                                                                     | sec.   | 2 byte unsigned | 1    | 3000 | 60      |
| 4    | S4F13: T3 send incomplete timeout.<br><b>Note:</b> The default value for T3 is taken from the recommended default value in the SEMI specification manual.                                                                                       | sec.   | 2 byte unsigned | 1    | 3000 | 70      |
| 5    | Enable or disable static event reports. A two-byte unsigned integer is used to set 16 events. The LSB is for event 1 and the MSB is for event 16. A value of zero will disable all 16 events. See <a href="#">Appendix C</a> for event listing. |        | 2 byte unsigned | 0000 | FFFF | 0000    |
| 6    | Same as Equipment Constant ID 5 except for the event number. A two-byte unsigned integer is assigned for event 17 to event 32.                                                                                                                  |        | 2 byte unsigned | 0000 | FFFF | 0000    |
| 7    | Sets the Establish Communication message to be either S1F1 or S1F13. If set to false (default), then the S1F1 message will be used. If set to true, then the S1F13 message will be used.                                                        |        | 1 byte boolean  | 0    | 1    | 0       |
| 8    | Sets the Spool Overwrite flag. If set to true, then the message spool will overwrite the oldest message when the spooled message area becomes full. If set to false, then the new messages will be dropped.                                     |        | 1 byte boolean  | 0    | 1    | 0       |
| 9    | Sets the Max. Spool Transmit message value. The minimum value is 0 messages and the max. (default) value is 250 messages. This value is used with the S2F43 spooling command.                                                                   | # msgs | 2 byte unsigned | 0    | 250  | 250     |
| 10   | GEM Equipment Flag.                                                                                                                                                                                                                             |        | 1 byte boolean  | 0    | 1    | 0       |
| 11   | Same as Equipment Constant ID 5 except for the event number. A two-byte unsigned integer is assigned for event 33 to event 48.                                                                                                                  |        | 2 byte unsigned | 0000 | FFFF | 0000    |



## Appendix B—Equipment Constants

---

| ECID | Description                                                                                                                                      | Units | Format          | Min. | Max. | Default |
|------|--------------------------------------------------------------------------------------------------------------------------------------------------|-------|-----------------|------|------|---------|
| 12   | Same as Equipment Constant ID 5 except for the event number. A two-byte unsigned integer is assigned for event 49 to event 64.                   |       | 2 byte unsigned | 0000 | FFFF | 0000    |
| 13   | Sets Four-Digit Year Flag. Year 2000 compliance with 16 digit date and time format. If flag is set, 16-digit format; otherwise, 12-digit format. |       | 1 byte boolean  | 0    | 1    | 0       |
| 14   | Auto Query S3F11. Aspen will send S3F11 if MID is not assigned in remote mode.                                                                   |       | 1 byte boolean  | 0    | 1    | 0       |
| 15   | Spooling Enabled / Disabled. If set to true, then message spooling is enabled. If set to false, then message spooling is disabled.               |       | 1 byte boolean  | 0    | 1    | 0       |

## Appendix C—Event IDs

| <CEID> | Message                       | Event Description                                                                                                                                                                       |
|--------|-------------------------------|-----------------------------------------------------------------------------------------------------------------------------------------------------------------------------------------|
| 1      | Setup Started.                | Start of swap cassettes. The Aspen system has started to set up for processing a batch of wafers contained in the cassettes which were positioned onto the shuttle.                     |
| 2      | Setup Completed.              | Swap cassettes and pin search completed. The shuttle has completed its rotation and is in place for processing the wafers. The robot has completed its pin search calibration function. |
| 3      | Process Started.              | Batch processing started. Processing of a complete batch of wafers has started. This event occurs as soon as the robot starts placing wafers into the process chamber.                  |
| 4      | RF On.                        | Beginning of an RF cycle.                                                                                                                                                               |
| 5      | RF Off.                       | RF cycle has completed.                                                                                                                                                                 |
| 6      | Process Completed.            | Batch processing completed. The processing of a complete batch of wafers has completed. The robot is idle and the shuttle is available for rotation.                                    |
| 7      | Paused.                       | System held. The Aspen system has been placed in holding mode.                                                                                                                          |
| 8      | Resumed.                      | System un-held. The Aspen system has been taken out of the holding mode.                                                                                                                |
| 9      | Aborted.                      | Reset. Reset command has been entered by means of the keyboard or operator button.                                                                                                      |
| 10     | Alarm Paused.                 | Equipment Error Handler. Equipment is hard down. The Aspen equipment is unable to continue its operation and requires personnel attention.                                              |
| 11     | Alarm Cleared.                | Replied to Error Handler. The alarm pause has been cleared by personnel by way of the keyboard.                                                                                         |
| 12     | Left Cassette Removed.        | The left cassette has been removed from the outer cassette nests.                                                                                                                       |
| 13     | Left Cassette Inserted.       | The left cassette has been inserted in the outer cassette nests.                                                                                                                        |
| 14     | Process Step Started.         | Indicates the start of a processing step.                                                                                                                                               |
| 15     | Process Step Ended.           | Indicates the termination of a processing step.                                                                                                                                         |
| 16     | Wafer Process Started.        | Start of a wafer process cycle.                                                                                                                                                         |
| 17     | Wafer Process Ended.          | Completion of a wafer process cycle.                                                                                                                                                    |
| 18     | Cassette Door Up.             | The cassette door is in the open position.                                                                                                                                              |
| 19     | Cassette Door Down.           | The cassette door is in the closed position.                                                                                                                                            |
| 20     | Unload Material Request.      | Aspen is presenting finished cassettes for unload.                                                                                                                                      |
| 21     | Unloading Material Completed. | Finished cassettes have been removed.                                                                                                                                                   |
| 22     | Load Material Request.        | Aspen is requesting that material be loaded.                                                                                                                                            |
| 23     | Loading Material Completed.   | One or two cassettes have been loaded.                                                                                                                                                  |

## Appendix C—Event IDs

| <CEID> | Message                                        | Event Description                                                                                                                                                                                                                |
|--------|------------------------------------------------|----------------------------------------------------------------------------------------------------------------------------------------------------------------------------------------------------------------------------------|
| 24     | RF Power Zone Transition.                      |                                                                                                                                                                                                                                  |
| 25     | Chamber Pressure Zone Transition.              |                                                                                                                                                                                                                                  |
| 26     | Gas 1 Flow Zone Transition.                    |                                                                                                                                                                                                                                  |
| 27     | Gas 2 Flow Zone Transition.                    |                                                                                                                                                                                                                                  |
| 28     | Gas 3 Flow Zone Transition.                    |                                                                                                                                                                                                                                  |
| 29     | Chamber Temperature Zone Transition.           |                                                                                                                                                                                                                                  |
| 30     | Spooling Deactivated.                          |                                                                                                                                                                                                                                  |
| 31     | End Point Completed.                           |                                                                                                                                                                                                                                  |
| 32     | Step Sampling Data Reporting.                  | Need to set SII field of recipe step to 'Y' for this event. The event will occur at half of the elapsed RF time if the step is not an end point step. For an end point step, the event will occur after end point has completed. |
| 33     | Top Wafer Number Request in Remote Mode.       |                                                                                                                                                                                                                                  |
| 34     | Bottom Wafer Number Request in Remote Mode.    |                                                                                                                                                                                                                                  |
| 35     | Recipe Selection Request in Remote Mode.       |                                                                                                                                                                                                                                  |
| 36     | Right Cassette Removed.                        | The right cassette has been removed from the outer cassette nests.                                                                                                                                                               |
| 37     | Right Cassette Inserted.                       | The right cassette has been inserted in the outer cassette nests.                                                                                                                                                                |
| 38     | Run Request in Remote Mode.                    |                                                                                                                                                                                                                                  |
| 39     | Prompt to Open Cassette Door.                  |                                                                                                                                                                                                                                  |
| 40     | Equipment Mode Changed.                        | Equipment mode switched between Operator/ Remote Mode and Engineering Mode.                                                                                                                                                      |
| 41     | Ready to Return Cassettes.                     | Inner cassettes were completed with no outer cassettes loaded. Send the event every five minutes.                                                                                                                                |
| 42     | Idle Notification.                             | Aspen idle timeout notification.                                                                                                                                                                                                 |
| 43     | Process Chamber Enabled/Disabled.              | Chamber has switched between enabled and disabled.                                                                                                                                                                               |
| 44     | Operator Changed ON-LINE to OFF-LINE.          |                                                                                                                                                                                                                                  |
| 45     | Prompt to Close Cassette Door.                 |                                                                                                                                                                                                                                  |
| 46     | Leak Test Completed.                           |                                                                                                                                                                                                                                  |
| 47     | Error or Warning Message.                      |                                                                                                                                                                                                                                  |
| 48     | Route Request in Remote Mode.                  | Tool requests route to run. (SLE Software Only)                                                                                                                                                                                  |
| *49    | End Point Completed. (Second chamber)          |                                                                                                                                                                                                                                  |
| *50    | Step Sampling Data Reporting. (Second chamber) |                                                                                                                                                                                                                                  |
| *51    | RF On. (Second chamber)                        | Beginning of an RF cycle.                                                                                                                                                                                                        |
| *52    | RF Off. (Second chamber)                       | RF cycle has completed.                                                                                                                                                                                                          |
| *53    | Process Step Started. (Second chamber)         | Indicates the start of a processing step.                                                                                                                                                                                        |
| *54    | Process Step Completed. (Second chamber)       | Indicates the termination of a processing step.                                                                                                                                                                                  |

| <CEID> | Message                                                    | Event Description                              |
|--------|------------------------------------------------------------|------------------------------------------------|
| *55    | Wafer Process Started. (Second chamber)                    | Start of a wafer process cycle.                |
| *56    | Wafer Process Completed. (Second chamber)                  | Completion of a wafer process cycle.           |
| *57    | RF Power Zone Transition. (Second chamber)                 |                                                |
| *58    | Chamber Pressure Zone Transition. (Second chamber)         |                                                |
| *59    | Gas 1 Flow Zone Transition. (Second chamber)               |                                                |
| *60    | Gas 2 Flow Zone Transition. (Second chamber)               |                                                |
| *61    | Gas 3 Flow Zone Transition. (Second chamber)               |                                                |
| *62    | Chamber Temperature Zone Transition (Second chamber)       |                                                |
| *63    | Process Chamber Enabled/Disabled. (Second chamber)         | Chamber switched between enabled and disabled. |
| 64     | Reserved.                                                  |                                                |
| 65     | Reserved.                                                  | Special feature for Hyundai in SLE software.   |
| 66     | Wafer Count Error.                                         |                                                |
| 67     | Request to Verify Single Cassette in Operator Choice Mode. |                                                |
| 68     | Request for Left Wafer Number.                             |                                                |
| 69     | Request for Right Wafer Number.                            |                                                |
| 70     | Left Pod in Place.                                         | (Fortrend PIO)                                 |
| 71     | Right Pod in Place.                                        | (Fortrend PIO)                                 |
| 72     | Load Left Cassette Request.                                | (Fortrend PIO)                                 |
| 73     | Load Right Cassette Request.                               | (Fortrend PIO)                                 |
| 74     | Load Left Cassette Completed.                              | (Fortrend PIO)                                 |
| 75     | Load Right Cassette Completed.                             | (Fortrend PIO)                                 |
| 76     | Unload Left Cassette Request.                              | (Fortrend PIO)                                 |
| 77     | Unload Right Cassette Request.                             | (Fortrend PIO)                                 |
| 78     | Unload Left Cassette Completed.                            | (Fortrend PIO)                                 |
| 79     | Unload Right Cassette Completed.                           | (Fortrend PIO)                                 |
| 80     | Ready to Remove Left Pod.                                  | (Fortrend PIO)                                 |
| 81     | Ready to Remove Right Pod.                                 | (Fortrend PIO)                                 |
| 82     | Left Pod Removed.                                          | (Fortrend PIO)                                 |
| 83     | Right Pod Removed.                                         | (Fortrend PIO)                                 |
| 84     | Left PIO Communication Error.                              | (Fortrend PIO)                                 |
| 85     | Right PIO Communication Error.                             | (Fortrend PIO)                                 |
| 86     | Wafer Mapping Completed.                                   |                                                |
| 87     | Cassette Shuttle Up.                                       |                                                |

## Appendix C—Event IDs

| <CEID> | Message                             | Event Description                                                                          |
|--------|-------------------------------------|--------------------------------------------------------------------------------------------|
| 88     | End Point Failure. (First Chamber)  | An end point failure occurs. Check VID 81 End Point Failure Data for detailed information. |
| 89     | Equipment Status Changed.           |                                                                                            |
| 90     | End Point Failure. (Second Chamber) | An end point failure occurs. Check VID 81 End Point Failure Data for detailed information. |
| 91     | AGV Unload Left Completed.          | (AGV)                                                                                      |
| 92     | AGV Unload Right Completed.         | (AGV)                                                                                      |
| 93     | AGV Load Left Completed.            | (AGV)                                                                                      |
| 94     | AGV Load Right Completed.           | (AGV)                                                                                      |
| 95     | AGV Unload Left Request.            | (AGV)                                                                                      |
| 96     | AGV Unload Right Request.           | (AGV)                                                                                      |
| 97     | AGV Load Left Request.              | (AGV)                                                                                      |
| 98     | AGV Load Right Request.             | (AGV)                                                                                      |
| 99     | Reserved.                           |                                                                                            |
| 100    | Left Pod In Place.                  | (SMIF) Pod Placed on SMIF.                                                                 |
| 101    | Right Pod In Place.                 | (SMIF) Pod Placed on SMIF.                                                                 |
| 102    | Load Left Pod Request.              | (SMIF) Pod is locked and ready to load.                                                    |
| 103    | Load Right Pod Request.             | (SMIF) Pod is locked and ready to load.                                                    |
| 104    | Load Left Pod Completed.            | (SMIF) Cassette is loaded on tool from pod.                                                |
| 105    | Load Right Pod Completed.           | (SMIF) Cassette is loaded on tool from pod.                                                |
| 106    | Unload Left Pod Request.            | (SMIF) Cassette is ready to unload and no pod is on loader.                                |
| 107    | Unload Right Pod Request.           | (SMIF) Cassette is ready to unload and no pod is on loader.                                |
| 108    | Unload Left Pod Completed.          | (SMIF) Cassette unloaded from tool to pod.                                                 |
| 109    | Unload Right Pod Completed.         | (SMIF) Cassette unloaded from tool to pod.                                                 |
| 110    | Left Pod Ready to Remove.           | (SMIF) Pod unlocked and ready to remove from SMIF.                                         |
| 111    | Right Pod Ready to Remove.          | (SMIF) Pod unlocked and ready to remove from SMIF.                                         |
| 112    | Left Pod Removed.                   | (SMIF) Pod removed.                                                                        |
| 113    | Right Pod Removed.                  | (SMIF) Pod removed.                                                                        |
| 114    | Left Pod Communication Error.       | (SMIF)                                                                                     |
| 115    | Right Pod Communication Error.      | (SMIF)                                                                                     |
| 116    | Lock Left Pod Completed.            | (SMIF) Pod is locked on SMIF.                                                              |
| 117    | Lock Right Pod Completed.           | (SMIF) Pod is locked on SMIF.                                                              |
| 118    | Load Left Pod Incomplete.           | (SMIF)                                                                                     |
| 119    | Load Right Pod Incomplete.          | (SMIF)                                                                                     |
| 120    | Unload Left Pod Incomplete.         | (SMIF)                                                                                     |

| <CEID> | Message                                    | Event Description |
|--------|--------------------------------------------|-------------------|
| 121    | Unload Right Pod Incomplete.               | (SMIF)            |
| 122    | Reserved.                                  |                   |
| 123    | Reserved.                                  |                   |
| 124    | Reserved.                                  |                   |
| 125    | Reserved.                                  |                   |
| 126    | Reserved.                                  |                   |
| 127    | Reserved.                                  |                   |
| 128    | Reserved.                                  |                   |
| 129    | Reserved.                                  |                   |
| 130    | Reserved.                                  |                   |
| 131    | Reserved.                                  |                   |
| 132    | Preconditioning Start.                     |                   |
| 133    | Preconditioning Complete.                  |                   |
| *134   | Preconditioning Start. (Second Chamber)    |                   |
| *135   | Preconditioning Complete. (Second Chamber) |                   |
| 136    | Wafer Cycle Start.                         |                   |
| 137    | Wafer Cycle Complete.                      |                   |
| 138    | Recipe Modified.                           |                   |
| 139    | Recipe Route Modified.                     |                   |
| 140    | Gas 4 Zone Transition.                     |                   |
| 141    | Gas 5 Zone Transition.                     |                   |
| 142    | Gas 6 Zone Transition.                     |                   |
| 143    | Gas 7 Zone Transition.                     |                   |
| 144    | Gas 8 Zone Transition.                     |                   |
| *145   | Gas 4 Zone Transition. (Second chamber)    |                   |
| *146   | Gas 5 Zone Transition. (Second chamber)    |                   |
| *147   | Gas 6 Zone Transition. (Second chamber)    |                   |
| *148   | Gas 7 Zone Transition. (Second chamber)    |                   |
| *149   | Gas 8 Zone Transition. (Second chamber)    |                   |
| 150    | Low Power Zone Transition.                 |                   |
| 151    | Second Low Power Zone Transition.          |                   |
| 152    | Wafer Mapping Data Request.                |                   |

\* The second chamber's Event IDs are only valid in a dual-chamber system. If a system is configured with only one chamber, no matter on which side the chamber is mounted, the second chamber's Event IDs will be invalid. The Aspen system always uses the first set of Event IDs for single-chamber systems.

For dual-chamber systems, the first chamber is assigned to the RIGHT chamber and the second chamber is assigned to the BACK chamber.



## Appendix D—Variable IDs

The limit value of the items marked with \* in the Limit column can be defined by S2F87.

The available Aspen Variable IDs <VID> and associated data is as follows:

| <VID> | Data Description                                                                                                                  | Units | Format                 | Limit |
|-------|-----------------------------------------------------------------------------------------------------------------------------------|-------|------------------------|-------|
| 0     | Date and Time<br>yyymmddhhmmss if ECID 13 is set to 0.<br>yyyymmddhhmmsscc if ECID 13 is set to 1.                                |       | 12 or 16 byte<br>ASCII |       |
| 1     | Processing Recipe Name (First Chamber)                                                                                            |       | 25 byte ASCII          |       |
| 2     | Processing Recipe Step Number (First Chamber)                                                                                     |       | 2 byte integer         |       |
| 3     | RF Power Setting (First Chamber)                                                                                                  | Watts | 2 byte integer         |       |
| 4     | Process Pressure Setting (First Chamber)                                                                                          | Torr  | 4 byte floating        |       |
| 5     | RF Time Setting (First Chamber)                                                                                                   | sec   | 4 byte floating        |       |
| 6     | Gas 1 Flow Setting (First Chamber)                                                                                                | sccm  | 2 byte unsigned        |       |
| 7     | Gas 2 Flow Setting (First Chamber)                                                                                                | sccm  | 2 byte unsigned        |       |
| 8     | Gas 3 Flow Setting (First Chamber)                                                                                                | sccm  | 2 byte unsigned        |       |
| 9     | Process Delay Time (First Chamber)                                                                                                | sec   | 4 byte floating        |       |
| 10    | Temperature Setting (First Chamber)                                                                                               | °C    | 2 byte integer         |       |
| 11    | RF Forward Power Actual (First Chamber)                                                                                           | Watts | 2 byte integer         | *     |
| 12    | RF Elapsed Time Actual (First Chamber)                                                                                            | sec   | 4 byte floating        |       |
| 13    | Process Pressure Actual (First Chamber)                                                                                           | Torr  | 4 byte floating        | *     |
| 14    | Gas 1 Flow Actual (First Chamber)                                                                                                 | sccm  | 2 byte unsigned        | *     |
| 15    | Gas 2 Flow Actual (First Chamber)                                                                                                 | sccm  | 2 byte unsigned        | *     |
| 16    | Gas 3 Flow Actual (First Chamber)                                                                                                 | sccm  | 2 byte unsigned        | *     |
| 17    | Temperature Actual (First Chamber)                                                                                                | °C    | 2 byte integer         | *     |
| 18    | Left Wafer Number in Chamber (First Chamber)                                                                                      |       | 2 byte unsigned        |       |
| 19    | Loadlock Pressure                                                                                                                 | Torr  | 4 byte floating        |       |
| 20    | Shuttle Pressure                                                                                                                  | Torr  | 4 byte floating        |       |
| 21    | Left Outer Material ID                                                                                                            |       | 16 byte ASCII          |       |
| 22    | Right Outer Material ID                                                                                                           |       | 16 byte ASCII          |       |
| 23    | Left Inner Material ID                                                                                                            |       | 16 byte ASCII          |       |
| 24    | Right Inner Material ID                                                                                                           |       | 16 byte ASCII          |       |
| 25    | Aspen Equipment Mode<br>0 = Engineering Mode<br>1 = Operator Mode<br>2 = Remote Mode (Semi-Auto Mode)<br>3 = Auto Mode (AGV Mode) |       | 1 byte binary          |       |



## Appendix D—Variable IDs

| <VID> | Data Description                                                                                        | Units | Format          | Limit |
|-------|---------------------------------------------------------------------------------------------------------|-------|-----------------|-------|
| 26    | Aspen Equipment Status<br>0 = Idle<br>1 = Processing<br>2 = Paused<br>3 = Down                          |       | 1 byte binary   |       |
| 27    | Left Outer Cassette Nest Status<br>0 = No Cassette<br>1 = Unfinished Cassette<br>2 = Finished Cassette  |       | 1 byte binary   |       |
| 28    | Left Inner Cassette Nest Status<br>0 = No Cassette<br>1 = Unfinished Cassette<br>2 = Finished Cassette  |       | 1 byte binary   |       |
| 29    | Cassette Door Status<br>0 = Door Up<br>1 = Door Down<br>2 = Door Between Up and Down Position           |       | 1 byte binary   |       |
| 30    | RF Reverse Power Actual (First Chamber)                                                                 | Watts | 2 byte integer  |       |
| 31    | End Point Time (First Chamber)                                                                          | sec   | 4 byte floating |       |
| 32    | Right Wafer Number in Chamber (First Chamber)                                                           |       | 2 byte unsigned |       |
| 33    | Right Outer Cassette Nest Status<br>0 = No Cassette<br>1 = Unfinished Cassette<br>2 = Finished Cassette |       | 1 byte binary   |       |
| 34    | Right Inner Cassette Nest Status<br>0 = No Cassette<br>1 = Unfinished Cassette<br>2 = Finished Cassette |       | 1 byte binary   |       |
| 35    | Left Wafer Number on Top Plate Of Cooldown Chamber                                                      |       | 2 byte unsigned |       |
| 36    | Right Wafer Number on Bottom Plate of Cooldown Chamber                                                  |       | 2 byte unsigned |       |
| 37    | Left Wafer Number on Top Plate of Cooldown Chamber                                                      |       | 2 byte unsigned |       |
| 38    | Right Wafer Number on Bottom Plate of Cooldown Chamber                                                  |       | 2 byte unsigned |       |

**Appendix D—Variable IDs**

| <b>&lt;VID&gt;</b> | <b>Data Description</b>                                                                                                                                                                                                                                                                                                                                                                                                                                                                                                                                                                                | <b>Units</b> | <b>Format</b>   | <b>Limit</b> |
|--------------------|--------------------------------------------------------------------------------------------------------------------------------------------------------------------------------------------------------------------------------------------------------------------------------------------------------------------------------------------------------------------------------------------------------------------------------------------------------------------------------------------------------------------------------------------------------------------------------------------------------|--------------|-----------------|--------------|
| 39                 | Equipment Remote Status<br>0 = Not Ready to Load, Unload, or Run Outer Cassettes<br>1 = Ready to Open Cassette Door with Outer Cassettes Present<br>2 = Ready to Open Cassette Door Without Outer Cassettes Present<br>3 = Ready to Unload Outer Cassettes<br>4 = Ready to Load Outer Cassettes<br>5 = Ready to Accept the Top Wafer Number<br>6 = Ready to Accept the Bottom Wafer Number<br>7 = Ready to Accept the Recipe Number<br>8 = Ready to Run the Outer Cassettes<br>9 = Ready to have Wafer Map Accepted<br>10 = Ready to Accept Left Wafer Count<br>11 = Ready to Accept Right Wafer Count |              | 2 byte integer  |              |
| 40                 | End Point Left CO <sub>2</sub> Data (First Chamber)                                                                                                                                                                                                                                                                                                                                                                                                                                                                                                                                                    |              | 2 byte integer  |              |
| 41                 | End Point Left O <sub>2</sub> Data (First Chamber)                                                                                                                                                                                                                                                                                                                                                                                                                                                                                                                                                     |              | 2 byte integer  |              |
| 42                 | End Point Right CO <sub>2</sub> Data (First Chamber)                                                                                                                                                                                                                                                                                                                                                                                                                                                                                                                                                   |              | 2 byte integer  |              |
| 43                 | End Point Right O <sub>2</sub> Data (First Chamber)                                                                                                                                                                                                                                                                                                                                                                                                                                                                                                                                                    |              | 2 byte integer  |              |
| 44                 | Process Chamber Status (First Chamber)<br>0 = Disabled<br>1 = Enabled                                                                                                                                                                                                                                                                                                                                                                                                                                                                                                                                  |              | 2 byte integer  |              |
| 45                 | Wafers of Inner Cassettes Processed                                                                                                                                                                                                                                                                                                                                                                                                                                                                                                                                                                    |              | 2 byte integer  |              |
| 46                 | Outer Cassettes Recipe Name (First Chamber)                                                                                                                                                                                                                                                                                                                                                                                                                                                                                                                                                            |              | 25 byte ASCII   |              |
| 47                 | Inner Cassettes Recipe Number (First Chamber)                                                                                                                                                                                                                                                                                                                                                                                                                                                                                                                                                          |              | 2 byte integer  |              |
| 48                 | Outer Cassettes Recipe Number (First Chamber)                                                                                                                                                                                                                                                                                                                                                                                                                                                                                                                                                          |              | 2 byte integer  |              |
| 49                 | Chamber Location Process Chamber Variables<br>0 = Back Chamber Installed<br>1 = Right Chamber Installed<br>2 = Right and Back Chambers Installed                                                                                                                                                                                                                                                                                                                                                                                                                                                       |              | 2 byte integer  |              |
|                    |                                                                                                                                                                                                                                                                                                                                                                                                                                                                                                                                                                                                        |              |                 |              |
| *51                | Processing Recipe Name (Second Chamber)                                                                                                                                                                                                                                                                                                                                                                                                                                                                                                                                                                |              | 25 byte ASCII   |              |
| *52                | Processing Recipe Step Number (Second Chamber)                                                                                                                                                                                                                                                                                                                                                                                                                                                                                                                                                         |              | 2 byte integer  |              |
| *53                | RF Power Setting (Second Chamber)                                                                                                                                                                                                                                                                                                                                                                                                                                                                                                                                                                      | Watts        | 2 byte integer  |              |
| *54                | Process Pressure Setting (Second Chamber)                                                                                                                                                                                                                                                                                                                                                                                                                                                                                                                                                              | Torr         | 4 byte floating |              |
| *55                | RF Time Setting (Second Chamber)                                                                                                                                                                                                                                                                                                                                                                                                                                                                                                                                                                       | sec          | 4 byte floating |              |
| *56                | Gas 1 Flow Setting (Second Chamber)                                                                                                                                                                                                                                                                                                                                                                                                                                                                                                                                                                    | sccm         | 2 byte unsigned |              |
| *57                | Gas 2 Flow Setting (Second Chamber)                                                                                                                                                                                                                                                                                                                                                                                                                                                                                                                                                                    | sccm         | 2 byte unsigned |              |
| *58                | Gas 3 Flow Setting (Second Chamber)                                                                                                                                                                                                                                                                                                                                                                                                                                                                                                                                                                    | sccm         | 2 byte unsigned |              |
| *59                | Process Delay Time (Second Chamber)                                                                                                                                                                                                                                                                                                                                                                                                                                                                                                                                                                    | sec          | 4 byte floating |              |
| *60                | Temperature Setting (Second Chamber)                                                                                                                                                                                                                                                                                                                                                                                                                                                                                                                                                                   | °C           | 2 byte integer  |              |

**Appendix D—Variable IDs**

| <b>&lt;VID&gt;</b> | <b>Data Description</b>                                                                                                                                                                                                                                                                                                                          | <b>Units</b> | <b>Format</b>   | <b>Limit</b> |
|--------------------|--------------------------------------------------------------------------------------------------------------------------------------------------------------------------------------------------------------------------------------------------------------------------------------------------------------------------------------------------|--------------|-----------------|--------------|
| *61                | RF Forward Power Actual (Second Chamber)                                                                                                                                                                                                                                                                                                         | Watts        | 2 byte integer  |              |
| *62                | RF Elapsed Time Actual (Second Chamber)                                                                                                                                                                                                                                                                                                          | sec          | 4 byte floating |              |
| *63                | Process Pressure Actual (Second Chamber)                                                                                                                                                                                                                                                                                                         | Torr         | 4 byte floating |              |
| *64                | Gas 1 Flow Actual (Second Chamber)                                                                                                                                                                                                                                                                                                               | sccm         | 2 byte unsigned |              |
| *65                | Gas 2 Flow Actual (Second Chamber)                                                                                                                                                                                                                                                                                                               | sccm         | 2 byte unsigned |              |
| *66                | Gas 3 Flow Actual (Second Chamber)                                                                                                                                                                                                                                                                                                               | sccm         | 2 byte unsigned |              |
| *67                | Temperature Actual (Second Chamber)                                                                                                                                                                                                                                                                                                              | °C           | 2 byte integer  |              |
| *68                | Left Wafer Number in Chamber (Second Chamber)                                                                                                                                                                                                                                                                                                    |              | 2 byte unsigned |              |
| *69                | Right Wafer Number in Chamber (Second Chamber)                                                                                                                                                                                                                                                                                                   |              | 2 byte unsigned |              |
| *70                | RF Reverse Power Actual (Second Chamber)                                                                                                                                                                                                                                                                                                         | Watts        | 2 byte integer  |              |
| *71                | End Point Time (Second Chamber)                                                                                                                                                                                                                                                                                                                  | sec          | 4 byte floating |              |
| *72                | End Point Left CO <sub>2</sub> Data (Second Chamber)                                                                                                                                                                                                                                                                                             |              | 2 byte integer  |              |
| *73                | End Point Left O <sub>2</sub> Data (Second Chamber)                                                                                                                                                                                                                                                                                              |              | 2 byte integer  |              |
| *74                | End Point Right CO <sub>2</sub> Data (Second Chamber)                                                                                                                                                                                                                                                                                            |              | 2 byte integer  |              |
| *75                | End Point Right O <sub>2</sub> Data (Second Chamber)                                                                                                                                                                                                                                                                                             |              | 2 byte integer  |              |
| *76                | Process Chamber Status (Second Chamber)<br>0 = Disabled<br>1 = Enabled                                                                                                                                                                                                                                                                           |              | 1 byte binary   |              |
| *77                | Outer Cassettes Recipe Name (Second Chamber)                                                                                                                                                                                                                                                                                                     |              | 25 byte ASCII   |              |
| *78                | Inner Cassettes Recipe Number (Second Chamber)                                                                                                                                                                                                                                                                                                   |              | 2 byte integer  |              |
| *79                | Outer Cassettes Recipe Number (Second Chamber)                                                                                                                                                                                                                                                                                                   |              | 2 byte integer  |              |
| 80                 | Hex Option in the Configuration File<br>1H = Extension Exercise<br>4H = Lift Exercise<br>10H = No Pin Search<br>40H = Robot Exercise<br>100H = Display Wafer Map<br>200H = No Gas Checking<br>400H = Automatic Operator<br>800H = No Wafer on Pad Check<br>2000H = Inhibit RF Power Checking<br>4000H = Read End Point<br>8000H = Force Exercise |              | 2 byte unsigned |              |
| 81                 | End Point Failure Data (First Chamber)<br>Bit 0 - 3<br>0 = Side Chamber<br>Bit 4 - 7<br>0 = Left Head (facing the screen display)<br>1 = Right Head<br>Bit 8 - 15<br>1 - 26 = Wafer Number                                                                                                                                                       |              | 2 byte unsigned |              |

**Appendix D—Variable IDs**

| <b>&lt;VID&gt;</b> | <b>Data Description</b>                                                                                                                                                                                       | <b>Units</b> | <b>Format</b>   | <b>Limit</b> |
|--------------------|---------------------------------------------------------------------------------------------------------------------------------------------------------------------------------------------------------------|--------------|-----------------|--------------|
| 82                 | End Point Failure Data (Second Chamber)<br>Bit 0 - 3<br>1 = Back Chamber<br>Bit 4 - 7<br>0 = Left Head (facing the screen display)<br>1 = Right Head<br>Bit 8 - 15<br>1 - 26 = Wafer Number                   |              | 2 byte unsigned |              |
| 91                 | Left Outer Cassette ID                                                                                                                                                                                        |              | 18 byte ASCII   |              |
| 92                 | Right Outer Cassette ID                                                                                                                                                                                       |              | 18 byte ASCII   |              |
| 93                 | Left Inner Cassette ID                                                                                                                                                                                        |              | 18 byte ASCII   |              |
| 94                 | Right Inner Cassette ID                                                                                                                                                                                       |              | 18 byte ASCII   |              |
| 95                 | Operator ID                                                                                                                                                                                                   |              | 18 byte ASCII   |              |
| 100                | Total Wafers                                                                                                                                                                                                  |              | 4 byte unsigned |              |
| 101                | Pin Search Data                                                                                                                                                                                               |              | 41 byte ASCII   |              |
| 102                | Leak Test Data                                                                                                                                                                                                |              | 2 byte unsigned |              |
| 103                | Error or Warning Message                                                                                                                                                                                      |              | 80 byte ASCII   |              |
| 104                | Left Wafer Map (SMIF Wafer Map)                                                                                                                                                                               |              | 4 byte unsigned |              |
| 105                | Right Wafer Map (SMIF Wafer Map)                                                                                                                                                                              |              | 4 byte unsigned |              |
| 106                | Left Outer Cassette Port (Hardware Port Number)                                                                                                                                                               |              | 2 byte integer  |              |
| 107                | Right Outer Cassette Port (Hardware Port Number)                                                                                                                                                              |              | 2 byte integer  |              |
| 108                | Wafer Account Mode<br>0 = Wafer Locations (Top & Bottom Wafer Numbers Entered)<br>1 = Wafer Counts with Lot ID (Left ID, Left Count, etc.)<br>2 = Wafer Counts without Lot ID (Left Count, Right Count, etc.) |              | 2 byte integer  |              |
| 109                | Left Outer Wafer Number Assigned                                                                                                                                                                              |              | 2 byte integer  |              |
| 110                | Right Outer Wafer Number Assigned                                                                                                                                                                             |              | 2 byte integer  |              |
| 111                | Left Outer Wafer Number Processed                                                                                                                                                                             |              | 2 byte integer  |              |
| 112                | Right Outer Wafer Number Processed                                                                                                                                                                            |              | 2 byte integer  |              |
| 113                | Left Inner Wafer Number Assigned                                                                                                                                                                              |              | 2 byte integer  |              |
| 114                | Right Inner Wafer Number Assigned                                                                                                                                                                             |              | 2 byte integer  |              |
| 115                | Left Inner Wafer Number Processed                                                                                                                                                                             |              | 2 byte integer  |              |
| 116                | Right Inner Wafer Number Processed                                                                                                                                                                            |              | 2 byte integer  |              |

**Appendix D—Variable IDs**

| <b>&lt;VID&gt;</b> | <b>Data Description</b>                                                                                                                                 | <b>Units</b> | <b>Format</b>   | <b>Limit</b> |
|--------------------|---------------------------------------------------------------------------------------------------------------------------------------------------------|--------------|-----------------|--------------|
| 117                | Chamber Selected for Recipe Load<br>(Returns 10 for Side Chamber; Returns 11 for Back Chamber)                                                          |              | 2 byte integer  |              |
| 158                | Inner Routing Recipe Number                                                                                                                             |              | 2 byte integer  |              |
| 159                | Outer Routing Recipe Number                                                                                                                             |              | 2 byte integer  |              |
| 160                | Inner Routing Selection<br>0 = Right Chamber Only<br>1 = Back Chamber Only<br>2 = Parallel<br>3 = Sequential, Right First<br>4 = Sequential, Back First |              | 2 byte integer  |              |
| 161                | Outer Routing Selection<br>0 = Right Chamber Only<br>1 = Back Chamber Only<br>2 = Parallel<br>3 = Sequential, Right First<br>4 = Sequential, Back First |              | 2 byte integer  |              |
| 162                | Process Mode (First Chamber)<br>0 = Regular Process<br>1 = Endpoint Calibration<br>2 = Precondition Process                                             |              | 2 byte integer  |              |
| 163                | Process Mode (Second Chamber)<br>0 = Regular Process<br>1 = Endpoint Calibration<br>2 = Precondition Process                                            |              | 2 byte integer  |              |
| 164                | Left Wafer Number Cycle Start/Complete                                                                                                                  |              | 2 byte integer  |              |
| 165                | Right Wafer Number Cycle Start/Complete                                                                                                                 |              | 2 byte integer  |              |
| 166                | Left Wafer Endpoint Time Independent Head (First Chamber)                                                                                               |              | 4 byte floating |              |
| 167                | Right Wafer Endpoint Time Independent Head (First Chamber)                                                                                              |              | 4 byte floating |              |
| 168                | Left Wafer Endpoint Time Independent Head (Second Chamber)                                                                                              |              | 4 byte floating |              |
| 169                | Right Wafer Endpoint Time Independent Head (Second Chamber)                                                                                             |              | 4 byte floating |              |
| 170                | Right Chamber RF Run Time (Hours)                                                                                                                       |              | 4 byte integer  |              |
| 171                | Second Right Chamber RF Run Time (Hours)                                                                                                                |              | 4 byte integer  |              |
| 172                | Third Right Chamber RF Run Time (Hours)                                                                                                                 |              | 4 byte integer  |              |
| 173                | Fourth Right Chamber RF Run Time (Hours)                                                                                                                |              | 4 byte integer  |              |
| 174                | Fifth Right Chamber RF Run Time (Hours)                                                                                                                 |              | 4 byte integer  |              |
| 175                | Back Chamber RF Run Time (Hours)                                                                                                                        |              | 4 byte integer  |              |

**Appendix D—Variable IDs**

| <b>&lt;VID&gt;</b> | <b>Data Description</b>                                                                              | <b>Units</b> | <b>Format</b>          | <b>Limit</b> |
|--------------------|------------------------------------------------------------------------------------------------------|--------------|------------------------|--------------|
| 176                | Second Back Chamber RF Run Time (Hours)                                                              |              | 4 byte integer         |              |
| 177                | Third Back Chamber RF Run Time (Hours)                                                               |              | 4 byte integer         |              |
| 178                | Fourth Back Chamber RF Run Time (Hours)                                                              |              | 4 byte integer         |              |
| 179                | Fifth Back Chamber RF Run Time (Hours)                                                               |              | 4 byte integer         |              |
|                    |                                                                                                      |              |                        |              |
| 181                | Right Chamber Gas 1 MFC Size                                                                         |              | 2 byte integer         |              |
| 182                | Right Chamber Gas 2 MFC Size                                                                         |              | 2 byte integer         |              |
| 183                | Right Chamber Gas 3 MFC Size                                                                         |              | 2 byte integer         |              |
| 184                | Right Chamber Gas 4 MFC Size                                                                         |              | 2 byte integer         |              |
| 185                | Right Chamber Gas 5 MFC Size                                                                         |              | 2 byte integer         |              |
| 186                | Right Chamber Gas 6 MFC Size                                                                         |              | 2 byte integer         |              |
| 187                | Right Chamber Gas 7 MFC Size                                                                         |              | 2 byte integer         |              |
| 188                | Right Chamber Gas 8 MFC Size                                                                         |              | 2 byte integer         |              |
|                    |                                                                                                      |              |                        |              |
| 191                | Back Chamber Gas 1 MFC Size                                                                          |              | 2 byte integer         |              |
| 192                | Back Chamber Gas 2 MFC Size                                                                          |              | 2 byte integer         |              |
| 193                | Back Chamber Gas 3 MFC Size                                                                          |              | 2 byte integer         |              |
| 194                | Back Chamber Gas 4 MFC Size                                                                          |              | 2 byte integer         |              |
| 195                | Back Chamber Gas 5 MFC Size                                                                          |              | 2 byte integer         |              |
| 196                | Back Chamber Gas 6 MFC Size                                                                          |              | 2 byte integer         |              |
| 197                | Back Chamber Gas 7 MFC Size                                                                          |              | 2 byte integer         |              |
| 198                | Back Chamber Gas 8 MFC Size                                                                          |              | 2 byte integer         |              |
|                    |                                                                                                      |              |                        |              |
| 200                | Spool Count Actual                                                                                   |              | 2 byte unsigned        |              |
| 201                | Spool Count Total                                                                                    |              | 4 byte unsigned        |              |
| 202                | Spool Start Time<br>yymmddhhmmss if ECID 13 is set to 0.<br>yyyymmddhhmmsscc if ECID 13 is set to 1. |              | 12 or 16 byte<br>ASCII |              |
| 203                | Spool Full Time<br>yymmddhhmmss if ECID 13 is set to 0.<br>yyyymmddhhmmsscc if ECID 13 is set to 1.  |              | 12 or 16 byte<br>ASCII |              |
| 204                | Spool State<br>0 = Spool Inactive<br>1 = Spool Active                                                |              | 1 byte binary          |              |
| 205                | Route Enabling Inner Cassettes<br>0 = Common Recipe<br>1 = Routing Mode<br>2 = Recipe Per Wafer      |              | 1 byte binary          |              |

**Appendix D—Variable IDs**

| <b>&lt;VID&gt;</b> | <b>Data Description</b>                                                                         | <b>Units</b> | <b>Format</b>   | <b>Limit</b> |
|--------------------|-------------------------------------------------------------------------------------------------|--------------|-----------------|--------------|
| 206                | Route Enabling Outer Cassettes<br>0 = Common Recipe<br>1 = Routing Mode<br>2 = Recipe Per Wafer |              | 1 byte binary   |              |
| 207                | Current Active Chamber<br>0 = Side Chamber<br>1 = Back Chamber                                  |              | 2 byte unsigned |              |
|                    |                                                                                                 |              |                 |              |
| 211                | Number of the Recipe Modified                                                                   |              | 2 byte unsigned |              |
| 212                | Name of the Recipe Modified                                                                     |              | 25 byte ASCII   |              |
| 213                | Number of the Recipe Route Modified                                                             |              | 2 byte unsigned |              |
| 214                | Name of the Recipe Route Modified                                                               |              | 40 byte ASCII   |              |
| 215                | Tool Total Maintenance Wafer Count                                                              |              | 4 byte integer  |              |
| 216                | Right Chamber Processed Wafer Count                                                             |              | 4 byte integer  |              |
| 217                | Second Right Chamber Processed Wafer Count                                                      |              | 4 byte integer  |              |
| 218                | Third Right Chamber Processed Wafer Count                                                       |              | 4 byte integer  |              |
| 219                | Fourth Right Chamber Processed Wafer Count                                                      |              | 4 byte integer  |              |
| 220                | Fifth Right Chamber Processed Wafer Count                                                       |              | 4 byte integer  |              |
| 221                | Back Chamber Processed Wafer Count                                                              |              | 4 byte integer  |              |
| 222                | Second Back Chamber Processed Wafer Count                                                       |              | 4 byte integer  |              |
| 223                | Third Back Chamber Processed Wafer Count                                                        |              | 4 byte integer  |              |
| 224                | Fourth Back Chamber Processed Wafer Count                                                       |              | 4 byte integer  |              |
| 225                | Fifth Back Chamber Processed Wafer Count                                                        |              | 4 byte integer  |              |
| 226                | Tool Total Maintenance Wafer Setpoint                                                           |              | 4 byte integer  |              |
| 227                | Right Chamber Wafer Setpoint                                                                    |              | 4 byte integer  |              |
| 228                | Second Right Chamber Wafer Setpoint                                                             |              | 4 byte integer  |              |
| 229                | Third Right Chamber Wafer Setpoint                                                              |              | 4 byte integer  |              |
| 230                | Fourth Right Chamber Wafer Setpoint                                                             |              | 4 byte integer  |              |
| 231                | Fifth Right Chamber Wafer Setpoint                                                              |              | 4 byte integer  |              |
| 232                | Tool Total Maintenance Wafer Setpoint                                                           |              | 4 byte integer  |              |
| 233                | Back Chamber Wafer Setpoint                                                                     |              | 4 byte integer  |              |
| 234                | Second Back Chamber Wafer Setpoint                                                              |              | 4 byte integer  |              |
| 235                | Third Back Chamber Wafer Setpoint                                                               |              | 4 byte integer  |              |
| 236                | Fourth Back Chamber Wafer Setpoint                                                              |              | 4 byte integer  |              |
| 237                | Fifth Back Chamber Wafer Setpoint                                                               |              | 4 byte integer  |              |
| 238                | Right Chamber RF Run Setpoint (Hours)                                                           |              | 4 byte integer  |              |
| 239                | Second Right Chamber RF Run Setpoint (Hours)                                                    |              | 4 byte integer  |              |
| 240                | Third Right Chamber RF Run Setpoint (Hours)                                                     |              | 4 byte integer  |              |

**Appendix D—Variable IDs**

| <b>&lt;VID&gt;</b> | <b>Data Description</b>                      | <b>Units</b> | <b>Format</b>   | <b>Limit</b> |
|--------------------|----------------------------------------------|--------------|-----------------|--------------|
| 241                | Fourth Right Chamber RF Run Setpoint (Hours) |              | 4 byte integer  |              |
| 242                | Fifth Right Chamber RF Run Setpoint (Hours)  |              | 4 byte integer  |              |
| 243                | Back Chamber RF Run Setpoint (Hours)         |              | 4 byte integer  |              |
| 244                | Second Back Chamber RF Run Setpoint (Hours)  |              | 4 byte integer  |              |
| 245                | Third Back Chamber RF Run Setpoint (Hours)   |              | 4 byte integer  |              |
| 246                | Fourth Back Chamber RF Run Setpoint (Hours)  |              | 4 byte integer  |              |
| 247                | Fifth Back Chamber RF Run Setpoint (Hours)   |              | 4 byte integer  |              |
|                    |                                              |              |                 |              |
| 301                | Total RF Time (First Chamber)                |              | 4 byte floating |              |
| 302                | Gas 4 Flow Set (First Chamber)               | sccm         | 2 byte unsigned |              |
| 303                | Gas 5 Flow Set (First Chamber)               | sccm         | 2 byte unsigned |              |
| 304                | Gas 6 Flow Set (First Chamber)               | sccm         | 2 byte unsigned |              |
| 305                | Gas 7 Flow Set (First Chamber)               | sccm         | 2 byte unsigned |              |
| 306                | Gas 8 Flow Set (First Chamber)               | sccm         | 2 byte unsigned |              |
| 307                | Gas 4 Flow Actual (First Chamber)            | sccm         | 2 byte unsigned |              |
| 308                | Gas 5 Flow Actual (First Chamber)            | sccm         | 2 byte unsigned |              |
| 309                | Gas 6 Flow Actual (First Chamber)            | sccm         | 2 byte unsigned |              |
| 310                | Gas 7 Flow Actual (First Chamber)            | sccm         | 2 byte unsigned |              |
| 311                | Gas 8 Flow Actual (First Chamber)            | sccm         | 2 byte unsigned |              |
|                    |                                              |              |                 |              |
| *401               | Total RF Time (Second Chamber)               |              | 4 byte floating |              |
| *402               | Gas 4 Flow Set (Second Chamber)              | sccm         | 2 byte unsigned |              |
| *403               | Gas 5 Flow Set (Second Chamber)              | sccm         | 2 byte unsigned |              |
| *404               | Gas 6 Flow Set (Second Chamber)              | sccm         | 2 byte unsigned |              |
| *405               | Gas 7 Flow Set (Second Chamber)              | sccm         | 2 byte unsigned |              |
| *406               | Gas 8 Flow Set (Second Chamber)              | sccm         | 2 byte unsigned |              |
| *407               | Gas 4 Flow Actual (Second Chamber)           | sccm         | 2 byte unsigned |              |
| *408               | Gas 5 Flow Actual (Second Chamber)           | sccm         | 2 byte unsigned |              |
| *409               | Gas 6 Flow Actual (Second Chamber)           | sccm         | 2 byte unsigned |              |
| *410               | Gas 7 Flow Actual (Second Chamber)           | sccm         | 2 byte unsigned |              |
| *411               | Gas 8 Flow Actual (Second Chamber)           | sccm         | 2 byte unsigned |              |
|                    |                                              |              |                 |              |
| 501                | Lot RF Time Minimum (With Event 20)          | sec          | 2 byte unsigned |              |
| 502                | Lot RF Time Maximum (With Event 20)          | sec          | 2 byte unsigned |              |
| 503                | Lot RF Time Mean (With Event 20)             | sec          | 2 byte unsigned |              |
| 504                | Lot RF Time Sigma (With Event 20)            | sec          | 2 byte unsigned |              |
|                    |                                              |              |                 |              |



**Appendix D—Variable IDs**

| <b>&lt;VID&gt;</b> | <b>Data Description</b>                                | <b>Units</b> | <b>Format</b>   | <b>Limit</b> |
|--------------------|--------------------------------------------------------|--------------|-----------------|--------------|
| 1001               | Chamber Pressure Statistics, Minimum (First Chamber)   | Torr         | 4 byte floating |              |
| 1002               | RF Power Statistics, Minimum (First Chamber)           | Watts        | 2 byte integer  |              |
| 1003               | Temperature Statistics, Minimum (First Chamber)        | °C           | 2 byte integer  |              |
| 1004               | Gas 1 Flow Statistics, Minimum (First Chamber)         | sccm         | 2 byte unsigned |              |
| 1005               | Gas 2 Flow Statistics, Minimum (First Chamber)         | sccm         | 2 byte unsigned |              |
| 1006               | Gas 3 Flow Statistics, Minimum (First Chamber)         | sccm         | 2 byte unsigned |              |
| 1007               | Gas 4 Flow Statistics, Minimum (First Chamber)         | sccm         | 2 byte unsigned |              |
| 1008               | Gas 5 Flow Statistics, Minimum (First Chamber)         | sccm         | 2 byte unsigned |              |
| 1009               | Gas 6 Flow Statistics, Minimum (First Chamber)         | sccm         | 2 byte unsigned |              |
| 1010               | Gas 7 Flow Statistics, Minimum (First Chamber)         | sccm         | 2 byte unsigned |              |
| 1011               | Gas 8 Flow Statistics, Minimum (First Chamber)         | sccm         | 2 byte unsigned |              |
|                    |                                                        |              |                 |              |
| 1101               | Chamber Pressure Statistics, Maximum (First Chamber)   | Torr         | 4 byte floating |              |
| 1102               | RF Power Statistics, Maximum (First Chamber)           | Watts        | 2 byte integer  |              |
| 1103               | Temperature Statistics, Maximum (First Chamber)        | °C           | 2 byte integer  |              |
| 1104               | Gas 1 Flow Statistics, Maximum (First Chamber)         | sccm         | 2 byte unsigned |              |
| 1105               | Gas 2 Flow Statistics, Maximum (First Chamber)         | sccm         | 2 byte unsigned |              |
| 1106               | Gas 3 Flow Statistics, Maximum (First Chamber)         | sccm         | 2 byte unsigned |              |
| 1107               | Gas 4 Flow Statistics, Maximum (First Chamber)         | sccm         | 2 byte unsigned |              |
| 1108               | Gas 5 Flow Statistics, Maximum (First Chamber)         | sccm         | 2 byte unsigned |              |
| 1109               | Gas 6 Flow Statistics, Maximum (First Chamber)         | sccm         | 2 byte unsigned |              |
| 1110               | Gas 7 Flow Statistics, Maximum (First Chamber)         | sccm         | 2 byte unsigned |              |
| 1111               | Gas 8 Flow Statistics, Maximum (First Chamber)         | sccm         | 2 byte unsigned |              |
|                    |                                                        |              |                 |              |
| 1201               | Chamber Pressure Statistics, Average (First Chamber)   | Torr         | 4 byte floating |              |
| 1202               | RF Power Statistics, Average (First Chamber)           | Watts        | 2 byte integer  |              |
| 1203               | Temperature Statistics, Average (First Chamber)        | °C           | 2 byte integer  |              |
| 1204               | Gas 1 Flow Statistics, Average (First Chamber)         | sccm         | 2 byte unsigned |              |
| 1205               | Gas 2 Flow Statistics, Average (First Chamber)         | sccm         | 2 byte unsigned |              |
| 1206               | Gas 3 Flow Statistics, Average (First Chamber)         | sccm         | 2 byte unsigned |              |
| 1207               | Gas 4 Flow Statistics, Average (First Chamber)         | sccm         | 2 byte unsigned |              |
| 1208               | Gas 5 Flow Statistics, Average (First Chamber)         | sccm         | 2 byte unsigned |              |
| 1209               | Gas 6 Flow Statistics, Average (First Chamber)         | sccm         | 2 byte unsigned |              |
| 1210               | Gas 7 Flow Statistics, Average (First Chamber)         | sccm         | 2 byte unsigned |              |
| 1211               | Gas 8 Flow Statistics, Average (First Chamber)         | sccm         | 2 byte unsigned |              |
|                    |                                                        |              |                 |              |
| 1301               | Chamber Pressure Statistics, Deviation (First Chamber) | Torr         | 4 byte floating |              |

**Appendix D—Variable IDs**

| <b>&lt;VID&gt;</b> | <b>Data Description</b>                               | <b>Units</b> | <b>Format</b>   | <b>Limit</b> |
|--------------------|-------------------------------------------------------|--------------|-----------------|--------------|
| 1302               | RF Power Statistics, Deviation (First Chamber)        | Watts        | 2 byte integer  |              |
| 1303               | Temperature Statistics, Deviation (First Chamber)     | °C           | 2 byte integer  |              |
| 1304               | Gas 1 Flow Statistics, Deviation (First Chamber)      | sccm         | 2 byte unsigned |              |
| 1305               | Gas 2 Flow Statistics, Deviation (First Chamber)      | sccm         | 2 byte unsigned |              |
| 1306               | Gas 3 Flow Statistics, Deviation (First Chamber)      | sccm         | 2 byte unsigned |              |
| 1307               | Gas 4 Flow Statistics, Deviation (First Chamber)      | sccm         | 2 byte unsigned |              |
| 1308               | Gas 5 Flow Statistics, Deviation (First Chamber)      | sccm         | 2 byte unsigned |              |
| 1309               | Gas 6 Flow Statistics, Deviation (First Chamber)      | sccm         | 2 byte unsigned |              |
| 1310               | Gas 7 Flow Statistics, Deviation (First Chamber)      | sccm         | 2 byte unsigned |              |
| 1311               | Gas 8 Flow Statistics, Deviation (First Chamber)      | sccm         | 2 byte unsigned |              |
|                    |                                                       |              |                 |              |
| *2001              | Chamber Pressure Statistics, Minimum (Second Chamber) | Torr         | 4 byte floating |              |
| *2002              | RF Power Statistics, Minimum (Second Chamber)         | Watts        | 2 byte integer  |              |
| *2003              | Temperature Statistics, Minimum (Second Chamber)      | °C           | 2 byte integer  |              |
| *2004              | Gas 1 Flow Statistics, Minimum (Second Chamber)       | sccm         | 2 byte unsigned |              |
| *2005              | Gas 2 Flow Statistics, Minimum (Second Chamber)       | sccm         | 2 byte unsigned |              |
| *2006              | Gas 3 Flow Statistics, Minimum (Second Chamber)       | sccm         | 2 byte unsigned |              |
| *2007              | Gas 4 Flow Statistics, Minimum (Second Chamber)       | sccm         | 2 byte unsigned |              |
| *2008              | Gas 5 Flow Statistics, Minimum (Second Chamber)       | sccm         | 2 byte unsigned |              |
| *2009              | Gas 6 Flow Statistics, Minimum (Second Chamber)       | sccm         | 2 byte unsigned |              |
| *2010              | Gas 7 Flow Statistics, Minimum (Second Chamber)       | sccm         | 2 byte unsigned |              |
| *2011              | Gas 8 Flow Statistics, Minimum (Second Chamber)       | sccm         | 2 byte unsigned |              |
|                    |                                                       |              |                 |              |
| *2101              | Chamber Pressure Statistics, Maximum (Second Chamber) | Torr         | 4 byte floating |              |
| *2102              | RF Power Statistics, Maximum (Second Chamber)         | Watts        | 2 byte integer  |              |
| *2103              | Temperature Statistics, Maximum (Second Chamber)      | °C           | 2 byte integer  |              |
| *2104              | Gas 1 Flow Statistics, Maximum (Second Chamber)       | sccm         | 2 byte unsigned |              |
| *2105              | Gas 2 Flow Statistics, Maximum (Second Chamber)       | sccm         | 2 byte unsigned |              |
| *2106              | Gas 3 Flow Statistics, Maximum (Second Chamber)       | sccm         | 2 byte unsigned |              |
| *2107              | Gas 4 Flow Statistics, Maximum (Second Chamber)       | sccm         | 2 byte unsigned |              |
| *2108              | Gas 5 Flow Statistics, Maximum (Second Chamber)       | sccm         | 2 byte unsigned |              |
| *2109              | Gas 6 Flow Statistics, Maximum (Second Chamber)       | sccm         | 2 byte unsigned |              |
| *2110              | Gas 7 Flow Statistics, Maximum (Second Chamber)       | sccm         | 2 byte unsigned |              |
| *2111              | Gas 8 Flow Statistics, Maximum (Second Chamber)       | sccm         | 2 byte unsigned |              |
|                    |                                                       |              |                 |              |

## Appendix D—Variable IDs

| <VID> | Data Description                                        | Units | Format          | Limit |
|-------|---------------------------------------------------------|-------|-----------------|-------|
| *2201 | Chamber Pressure Statistics, Average (Second Chamber)   | Torr  | 4 byte floating |       |
| *2202 | RF Power Statistics, Average (Second Chamber)           | Watts | 2 byte integer  |       |
| *2203 | Temperature Statistics, Average (Second Chamber)        | °C    | 2 byte integer  |       |
| *2204 | Gas 1 Flow Statistics, Average (Second Chamber)         | sccm  | 2 byte unsigned |       |
| *2205 | Gas 2 Flow Statistics, Average (Second Chamber)         | sccm  | 2 byte unsigned |       |
| *2206 | Gas 3 Flow Statistics, Average (Second Chamber)         | sccm  | 2 byte unsigned |       |
| *2207 | Gas 4 Flow Statistics, Average (Second Chamber)         | sccm  | 2 byte unsigned |       |
| *2208 | Gas 5 Flow Statistics, Average (Second Chamber)         | sccm  | 2 byte unsigned |       |
| *2209 | Gas 6 Flow Statistics, Average (Second Chamber)         | sccm  | 2 byte unsigned |       |
| *2210 | Gas 7 Flow Statistics, Average (Second Chamber)         | sccm  | 2 byte unsigned |       |
| *2211 | Gas 8 Flow Statistics, Average (Second Chamber)         | sccm  | 2 byte unsigned |       |
|       |                                                         |       |                 |       |
| *2301 | Chamber Pressure Statistics, Deviation (Second Chamber) | Torr  | 4 byte floating |       |
| *2302 | RF Power Statistics, Deviation (Second Chamber)         | Watts | 2 byte integer  |       |
| *2303 | Temperature Statistics, Deviation (Second Chamber)      | °C    | 2 byte integer  |       |
| *2304 | Gas 1 Flow Statistics, Deviation (Second Chamber)       | sccm  | 2 byte unsigned |       |
| *2305 | Gas 2 Flow Statistics, Deviation (Second Chamber)       | sccm  | 2 byte unsigned |       |
| *2306 | Gas 3 Flow Statistics, Deviation (Second Chamber)       | sccm  | 2 byte unsigned |       |
| *2307 | Gas 4 Flow Statistics, Deviation (Second Chamber)       | sccm  | 2 byte unsigned |       |
| *2308 | Gas 5 Flow Statistics, Deviation (Second Chamber)       | sccm  | 2 byte unsigned |       |
| *2309 | Gas 6 Flow Statistics, Deviation (Second Chamber)       | sccm  | 2 byte unsigned |       |
| *2310 | Gas 7 Flow Statistics, Deviation (Second Chamber)       | sccm  | 2 byte unsigned |       |
| *2311 | Gas 8 Flow Statistics, Deviation (Second Chamber)       | sccm  | 2 byte unsigned |       |

The above <VID> numbers can be used in S1F3, S2F33, and S6F3 for getting equipment status and defining a report.

\* The second chamber's Variable IDs are only valid in dual chamber systems. If a system is configured with only one chamber, no matter on which side the chamber is mounted, the second chamber's Variable IDs will be invalid. The Aspen system always uses the first set of Variable IDs for single-chamber systems.

For dual-chamber systems, the first chamber is assigned to the RIGHT chamber and the second chamber is assigned to the BACK chamber.

## Appendix E—Remote Commands

The available Aspen Remote Commands are as follows:

| <RCMD>         | Description                                                                                                                                                          | <CPNAME>                       | <CPVAL>                                                  |
|----------------|----------------------------------------------------------------------------------------------------------------------------------------------------------------------|--------------------------------|----------------------------------------------------------|
| TOP            | Set the Top Wafer Number of the Outer Cassettes in Wafer Location Mode.                                                                                              | WAFER                          | 2 byte unsigned<br>1-25/26                               |
| BOTTOM         | Set the Bottom Wafer Number of the Outer Cassettes in Wafer Location Mode.                                                                                           | WAFER                          | 2 byte unsigned<br>1-25/26                               |
| LEFT           | Set the number of wafers of the Left Outer Cassette in Wafer Count Mode.                                                                                             | WAFER                          | 2 byte unsigned<br>0-25/26                               |
| RIGHT          | Set the number of wafers of the Right Outer Cassette in Wafer Count Mode.                                                                                            | WAFER                          | 2 byte unsigned<br>0-25/26                               |
| RECIPE         | Set the outer cassettes recipe with number or name.                                                                                                                  | NUMBER or<br>NAME              | 2 byte unsigned<br>1-99 or max.<br>25 byte ASCII         |
| ROUTING        | Set the outer cassettes route with number.                                                                                                                           | NUMBER                         | 2 byte unsigned<br>1-99                                  |
| RUN CONTINUOUS | Select Run Continuous in the RUN MENU without parameters.                                                                                                            |                                |                                                          |
| RUN SINGLE     | Select Run Single in the RUN MENU without parameters.                                                                                                                |                                |                                                          |
| HOLD           | Hold System command without parameters.                                                                                                                              |                                |                                                          |
| CONTINUE       | Resume System command without parameters.                                                                                                                            |                                |                                                          |
| ABORT          | Reset System command without parameters.                                                                                                                             |                                |                                                          |
| NO CASSETTES   | No more cassettes to load without parameters.                                                                                                                        |                                |                                                          |
| SIGNAL_TOWER   | Control Signal Tower Lights on, off and flash.                                                                                                                       | RED<br>YELLOW<br>GREEN<br>BLUE | 1 byte ASCII<br>0 = Turn Off<br>1 = Turn On<br>2 = Flash |
| OPEN DOOR      | Open the cassette door without parameters. Aspen has to be in either Full-Auto or Semi-Auto Mode and Remote Mode. Command is not available with SMIF installations.  |                                |                                                          |
| CLOSE DOOR     | Close the cassette door without parameters. Aspen has to be in either Full-Auto or Semi-Auto Mode and Remote Mode. Command is not available with SMIF installations. |                                |                                                          |
| MANUAL         | Go to Manual Mode without parameters.                                                                                                                                |                                |                                                          |

## Appendix E—Remote Commands

| <RCMD>          | Description                                                                                               | <CPNAME> | <CPVAL>                                                                     |
|-----------------|-----------------------------------------------------------------------------------------------------------|----------|-----------------------------------------------------------------------------|
| SEMI-AUTO       | Go to Semi-Auto Mode without parameters.                                                                  |          |                                                                             |
| FULL-AUTO       | Go to Full-Auto Mode without parameters.                                                                  |          |                                                                             |
| LOAD CASSETTE   | Load one or two cassettes from pods. (SMIF)                                                               | PORT     | 1 byte binary<br>1= Left Cassette<br>2= Right Cassette<br>3= Both Cassettes |
| UNLOAD CASSETTE | Unload one or two cassettes to pods. (SMIF)                                                               | PORT     | 1 byte binary<br>1= Left Cassette<br>2= Right Cassette<br>3= Both Cassettes |
| BACK RECIPE     | Selects the Back Chamber for uploading or downloading recipes for the S7 Stream.                          |          |                                                                             |
| RIGHT RECIPE    | Selects the Right Chamber for uploading or downloading recipes for the S7 Stream.                         |          |                                                                             |
| SKIP EMPTY      | In Wafer Locations mode, skip any empty slots found by the paddle sensors.                                |          |                                                                             |
| NO EMPTY SLOT   | In Wafer Locations mode, do not skip any empty slots found by the paddle sensors.                         |          |                                                                             |
| OPERATOR        | Set operator ID for VID95                                                                                 | ID       | 18 byte ASCII                                                               |
| BUZZER ON       | Turn on buzzer without parameters.                                                                        |          |                                                                             |
| BUZZER OFF      | Turn off buzzer without parameters.                                                                       |          |                                                                             |
| LEAK TEST       | Start Leak Test without parameters.                                                                       |          |                                                                             |
| ENGINEER-MODE   | Go to Engineering Mode without parameters. The system must be idle and mconf Mode Change must be enabled. |          |                                                                             |
| SELECTION       | Same function as the Operation Keys.                                                                      | KEY      | 2 byte integer<br>1-6                                                       |
| LOCK POD        | Lock one or two pods. (SMIF)                                                                              | PORT     | 1 byte binary<br>1= Left Pod<br>2= Right Pod<br>3= Both Pods                |
| UNLOCK POD      | Unlock one or two pods. (SMIF)                                                                            | PORT     | 1 byte binary<br>1= Left Pod<br>2= Right Pod<br>3= Both Pods                |
| ACCEPT MAP      | Confirm wafer mapping data without parameters.                                                            |          |                                                                             |

| <RCMD>          | Description                                                                                                                                                                                                                                                                                                                                                                                                     | <CPNAME>                                                                                                                                            | <CPVAL>                                                             |
|-----------------|-----------------------------------------------------------------------------------------------------------------------------------------------------------------------------------------------------------------------------------------------------------------------------------------------------------------------------------------------------------------------------------------------------------------|-----------------------------------------------------------------------------------------------------------------------------------------------------|---------------------------------------------------------------------|
| REJECT MAP      | Reject wafer mapping data without parameters.                                                                                                                                                                                                                                                                                                                                                                   |                                                                                                                                                     |                                                                     |
| SINGLE CASSETTE | Confirm single cassette operation without parameters.                                                                                                                                                                                                                                                                                                                                                           |                                                                                                                                                     |                                                                     |
| HEX             | Set Hex Option in CN page:<br>1 = 1H = Extension Exercise<br>4 = 4H = Lift Exercise<br>16 = 10H = No Pin Search<br>64 = 40H = Robot Exercise<br>256 = 100H = Display Wafer Map<br>512 = 200H = No Gas Checking<br>1024 = 400H = Auto Marathon Operator<br>2048 = 800H = No Wafer on Pad Check<br>8192 = 2000H = Inhibit RF Power Check<br>16384 = 4000H = Read End Point<br>32768 = 8000H = Exercise Atmosphere | OPTION                                                                                                                                              | 2 byte unsigned<br>0 - 65535                                        |
| ACTIVE          | Define the Active Chamber only on a dual-chamber system. It also selects which chamber receives the wafer first if not in routing mode or a parallel route if in routing mode.                                                                                                                                                                                                                                  | CHAMBER                                                                                                                                             | 2 byte unsigned<br>1= Side Chamber<br>2= Back Chamber               |
| SLOT MAP        | Send Wafer Map from Host to Aspen to use for wafer processing.                                                                                                                                                                                                                                                                                                                                                  | Port 1 (left)<br>Port 2 (right)                                                                                                                     | Binary 00 or 01 to Max. Wafer Count 25 or 26                        |
| RESET           | Resets CN and CN C page counters for Wafers Processed and RF Hours.<br>(Note: Reset hours on the desired chamber by first selecting it with the ACTIVE command.)                                                                                                                                                                                                                                                | RF HOURS<br>RF HOURS2<br>RF HOURS3<br>RF HOURS4<br>RF HOURS5<br><br>WAFS PROC<br>WAFS PROC1<br>WAFS PROC2<br>WAFS PROC3<br>WAFS PROC4<br>WAFS PROC5 | 2 byte unsigned<br>0 - 32767<br><br>4 byte integer<br>0 - 2 Billion |



## Appendix F—Remote Control Operation

The Aspen Equipment is switched from Engineering Mode to Remote Mode by typing <TR> toggle remote on the equipment keyboard. The status screen will then display "Remote Mode." The Aspen can be returned to the Engineering Mode by typing <TR>. The Host can switch the Aspen to Remote Mode with the S2F41 Remote Command.

While in the remote control mode, the Aspen SECS II software tracks the state and status of the equipment by receiving state transition information from the equipment control software and then replying with the appropriate equipment control messages at the proper time. All of the control information is generated with the Aspen/SECS II software, while the host only supplies material handling and processing recipe information. The host can determine which of the three modes, Engineering, Operator, or Remote, the equipment is currently in by using Variable ID 25.

The equipment has two ports. When viewed from the front of the system, the first port is assigned to the left cassette, which has an ID of "1". The second port is assigned to the right cassette, which has an ID of "2". All requested processing recipes must reside on the Aspen system disk before they can be used for processing.

While in Remote Mode, with the host responding to the Aspen system that it has no more cassettes to process, the cassette door will remain open. To close the cassette door for some reason, the operator must change the Aspen to Operator Mode and select the option from the front panel screen. To resume the Remote Mode, the operator must change the Aspen system to Semi-Auto or Full-Auto Mode, and the cassette door will open automatically.

If the host is not using S4Fx (S4F1 / S4F17) to unload the cassettes, please disregard the next section.

### Using S4 Functions to Remove Cassettes from the Aspen Equipment

The Aspen system has finished processing the wafers and the cassettes are in the cassette nest and ready to be removed from the Aspen system.

After the wafers have been processed, the Aspen will swap the inner and outer cassettes, backfill the shuttle and open the cassette door. The host can detect the event of Unload Material Request, obtain the status of the outer cassettes, and initiate the Material Transfer Request function by issuing S4F17 with Port ID to the Aspen equipment.

The Aspen will accept the message S4F17 if the Aspen equipment is in Remote Control Mode and there is a finished cassette at the specified port waiting for the transfer; otherwise, the Aspen will acknowledge with an error to the host. Then, the Aspen sends a S4F1 message, Ready to Send Material, to the host and waits for the acknowledge. When the host is ready to receive the cassette, a message S4F3 will be sent to the Aspen Equipment. Upon the receipt of S4F3, the Aspen follows the status of the cassette to be removed. If the T1 timeout occurs before the removal of the cassette, the Aspen will send S4F9, Stuck in Sender, and S4F7, Not Ready to Send, to the host, so the host can stop its transfer mechanism. If the Aspen detects that the cassette is gone but fails to receive S4F5 before the T3 timeout, a message, S4F13, Send Incomplete Receiver, will be sent to the host.

If the second port also requires a cassette to be unloaded, the host should initiate the transfer sequence again.

If the host is not using S4Fx (S4F1 / S4F17) to load the cassettes, disregard the next section.



### Using S4 Functions to Insert Cassettes into the Aspen Equipment

If the Aspen finds a port available to receive the material, the Aspen sends a message S4F17 (Request to Receive Material) with Port ID, Request to Receive Material, to the host and waits for a reply.

If the host acknowledges the message and sends a message S4F1, Ready to Send, to the Aspen, the Aspen will send a message S4F3, Send Material, to advise the host that it is ready to receive material. If the Aspen detects that the material has been transferred at the specified port, two messages, S4F5 and S4F15, which are Handshake Complete and Material Received, will be sent to the host and the Aspen will stop the transfer mechanism. If material is not received before the T3 timeout, the Aspen sends a S4F11 message, Stuck in Receiver, to the host.

If a S4F18, Request to Receive Acknowledge, message, which is the response of the S4F17, Request to Receive Material, message, indicates that the host is busy, the Aspen will wait for a minute and initiate the transfer again.

If a message S4F7, Not Ready to Send, is received by the Aspen which indicates that no material is being sent to the Aspen equipment, the Aspen monitor will display "**Host Has No Cass. To Send At Port #**". and sends a message S4F5, Handshake Complete, to the host. If none of two ports is loaded with material, Aspen will wait for a minute and initiate the transfer again.

If the material is loaded, the Aspen will then display "**Caution Cassette Door Will Be Closing**" on the monitor screen. This message will remain on the screen for 10 seconds and then the cassette door will begin to close.

If the Aspen detects that the cassettes are loaded without a Material ID, the Aspen will send S3F11, Material ID Request, to the host.

### Cassettes Transfer Without S4 Messages

The Aspen will not initiate the S4F17, Request to Receive Material, message and other S4 messages. In this case, the Aspen will ignore any S4 messages sent by the host. The host may send Material ID Send (S3F13) after the cassette has been manually loaded at the specified port.

### Aspen Requests to Open Cassette Door

An Event (39) will be sent to the host. If the Aspen is in Remote and Full-Auto or Semi-Auto mode, the host may send an OPEN DOOR command with S2F41, Host Command Send, to open the cassette door. Otherwise, the operator must press the panel button or palm buttons to open the door.

### Wafer Location Requests

#### 1. Aspen Requests Top Wafer Number

An Event (33) will be sent to the host to request the Top Wafer Number. The Aspen will wait for the host to send S2F41, Host Command Send, with TOP command and WAFER number.

#### 2. Aspen Requests Bottom Wafer Number

An Event (34) will be sent to the host to request the Bottom Wafer Number. The Aspen will wait for the host to send S2F41, Host Command Send, with BOTTOM command and WAFER number.

### 3. Aspen Requests Wafer Counts

An Event (68) will be sent to the host to request the Left Wafer Count and an Event (69) to request the Right Wafer Count. The Aspen will wait for the host to send S2F41 with the wafer counts.

---

**Note** If the Aspen tool has Wafer Mapping set to “Mattson” or “Receive from Host”, in the mconf screen, the Aspen system will not request any wafer data. It will go directly to the Route/Recipe Select screen after the cassettes are loaded.

---

**“Mattson” Wafer Mapping:** Once the “Run” command has been issued, the tool will map the wafers and send the information to the host computer while the cassette door is closing if Mattson wafer mapping hardware is installed.

**“From Host” Wafer Mapping:** The wafer map can be sent anytime before the cassette door is closed. The Aspen system will request the map from the host if it has not been received before the cassette door is closed with Event 152.

### 4. Aspen Requests Recipe Name, Number or Route Number

An Event (35) will be sent to the host. The Aspen will wait for the host to send S2F41 (Host Command Send) with RECIPE command and NUMBER or NAME. The Aspen will also accept S2F27, Initiate Process Request. If a zero length PPID of S2F27 (Initiate Process Report) is found, the Aspen will use the current outer recipe number. If in routing mode, an Event (48) will be sent to the host. The Aspen will wait for the host to send the S2F41 ROUTING command with NUMBER.

### 5. Aspen Requests Run Selection

An Event (38) will be sent to the host. The Aspen will wait for the host to send the S2F41 (Host Command Send) with RUN CONTINUOUS or RUN SINGLE command.

### 6. Aspen Requests to Close Cassette Door

An Event (45) will be sent to the host. If the Aspen is in Remote and Full-Auto or Semi-Auto Mode, the host may send the CLOSE DOOR command using S2F41 (Host Command Send) to close the cassette door; otherwise, the operator must press the panel button or palm buttons to close the door.

### 7. Aspen Requests Wafer Map Data and Reports Mapping Completed

If wafer mapping is set to “receive from host”, the Aspen sends Event (152) to request data if the data has not been received yet. If wafer mapping is set to “Mattson”, then wafer mapping is accomplished as the cassette door closes. Both Mattson Wafer Mapping and Wafer Map from Host will send Event (86) Wafer Mapping Completed.

### 8. Remote Command to Control the Operation

The host may also send the Remote Command Send (S2F21 or S2F41) to pause, reset, stop and resume the equipment operation.



## Appendix G—Process Program Body Description (PPBODY)

|       |                        |           |
|-------|------------------------|-----------|
| 13000 | Pressure               | (mTorr)   |
| 350   | RF Power               | (Watts)   |
| 150   | RF Time                | (dec sec) |
| 50    | Delay Time             | (dec sec) |
| 0     | Spare                  |           |
| 2000  | Gas 1 Flow             | (sccm)    |
| 0     | Gas 2 Flow             | (sccm)    |
| 0     | Gas 3 Flow             | (sccm)    |
| 0     | Gas 4 Flow             | (sccm)    |
| 0     | Gas 5 Flow             | (sccm)    |
| 0     | Gas 6 Flow             | (sccm)    |
| 0     | Gas 7 Flow             | (sccm)    |
| 0     | Gas 8 Flow             | (sccm)    |
| 0     | End Point              | (integer) |
| 0     | Process Attributes     | (integer) |
| 0     | Endpoint Detector Type | (integer) |
| 0     | Sensitivity Scale      | (integer) |
| 0     | Input Channel          | (integer) |
| 0     | Endpoint Delay Time    | (integer) |
| 0     | Upslope Value          | (integer) |
| 0     | Downslope Value        | (integer) |
| 0     | Maximum Debounce Count | (integer) |
| 0     | Final Threshold        | (integer) |
| 0     | Spare                  |           |
| 0     | Spare                  |           |
| 0     | Spare                  |           |
| 0     | Spare                  |           |
| 0     | Spare                  |           |
| 0     | Spare                  |           |
| 0     | Spare                  |           |
| 0     | Spare                  |           |
| 0     | Spare                  |           |
| 0     | Spare                  |           |
| 0     | Spare                  |           |
| 0     | Spare                  |           |
| 0     | Spare                  |           |
| 0     | Spare                  |           |
| 0     | Spare                  |           |

This is repeated for all 10 steps.



## Appendix H—Formatted Process Program

An example of the Formatted Process Program of the Aspen II system using SLE software is shown below:

Structure:

L,4

1. <PPID> (A25)
2. <MDLN> (A6)
3. <SOFTREV> (A6)
4. L,11
  1. L,2
    1. <CCODE> (U2)
    2. L,14

|          |                |      |
|----------|----------------|------|
| PPARM1.  | <TEMPERATURE>  | (I2) |
| PPARM2.  | <PRECONRECIPE> | (I2) |
| PPARM3.  | <PRECONFREQ>   | (I2) |
| PPARM4.  | <NUMBERSTEP>   | (I2) |
| PPARM5.  | <RESERVED>     | (I4) |
| PPARM6.  | <RESERVED>     | (I4) |
| PPARM7.  | <RESERVED>     | (I4) |
| PPARM8.  | <RESERVED>     | (I4) |
| PPARM9.  | <RESERVED>     | (I4) |
| PPARM10. | <RESERVED>     | (I4) |
| PPARM11. | <RESERVED>     | (I4) |
| PPARM12. | <RESERVED>     | (I4) |
| PPARM13. | <RESERVED>     | (I4) |
| PPARM14. | <RESERVED>     | (I4) |

---

**Note** The following step is repeated a total of ten times to represent each recipe step..

---

2. L,2

1. <CCODE> (U2)
2. L,36

|          |                       |      |
|----------|-----------------------|------|
| PPARM1.  | <PRESURE>             | (I4) |
| PPARM2.  | <RF POWER>            | (I2) |
| PPARM3.  | <RF TIME>             | (U2) |
| PPARM4.  | <RF DELAY TIME>       | (U2) |
| PPARM5.  | <RESERVED>            | (U2) |
| PPARM6.  | <GAS FLOW 1>          | (U2) |
| PPARM7.  | <GAS FLOW 2>          | (U2) |
| PPARM8.  | <GAS FLOW 3>          | (U2) |
| PPARM9.  | <GAS FLOW 4>          | (U2) |
| PPARM10. | <GAS FLOW 5>          | (U2) |
| PPARM11. | <GAS FLOW 6>          | (U2) |
| PPARM12. | <GAS FLOW 7>          | (U2) |
| PPARM13. | <GAS FLOW 8>          | (U2) |
| PPARM14. | <ENDPOINT>            | (U2) |
| PPARM15. | <ATTRIBUTE>           | (U2) |
| PPARM16. | <EPD INSTALL>         | (I2) |
| PPARM17. | <SCALE/SENSITIVITY>   | (I2) |
| PPARM18. | <EP CHANNEL>          | (I2) |
| PPARM19. | <START DELAY TIME>    | (I2) |
| PPARM20. | <UPSLOPE THRESHOLD>   | (I2) |
| PPARM21. | <DOWNSLOPE THRESHOLD> | (I4) |
| PPARM22. | <PEAK DEBOUNCE>       | (I4) |

## Appendix H—Formatted Process Program

---

PPARM23. <FINAL THRESHOLD> (I2)  
PPARM24. <MINIMUM PROCESS TIME> (I2)  
PPARM25. <FLAT PEAK DEVIATION> (I2)  
PPARM26. <FLAT PEAK COUNT> (I2)  
PPARM27. <MINIMUM CHANGE> (I2)  
PPARM28. <EP GAIN LEFT A> (I2)  
PPARM29. <EP GAIN LEFT B> (I2)  
PPARM30. <EP GAIN RIGHT A> (I2)  
PPARM31. <EP GAIN RIGHT B> (I2)  
PPARM32. <RESERVED> (I2)  
PPARM33. <RESERVED> (I2)  
PPARM34. <RESERVED> (I2)  
PPARM35. <RESERVED> (I2)  
PPARM36. <RESERVED> (I2)

## Appendix I—Programming Examples

### S2F15 New Equipment Constant Send

```
<L
 <L [2]
 <U2 0> * ECID: Retry host timer.
 <I2 60> * ECV: Seconds
 >
 <L [2]
 <U2 1> * ECID: Annotated Reports.
 <BOOLEAN T> * ECV: Enabled.
 >
 <L [2]
 <U2 2> * ECID: Send material timer.
 <I2 10> * ECV: Seconds
 >
 <L [2]
 <U2 3> * ECID: Receive material timer.
 <I2 60> * ECV: Seconds
 >
 <L [2]
 <U2 4> * ECID Handshake time-out timer.
 <I2 70> * ECV Seconds
 >
> .
```

### S2F23 Trace Initialize Send

```
<L [5]
 <U2 1>
 <A '000100'>
 <U2 10000>
 <U2 1>
 <L
 <U2 10> * SVID Set temperature
 <U2 17> * SVID Actual temperature
 <U2 13> * SVID Actual process pressure
 <U2 19> * SVID Actual loadlock pressure
 <U2 20> * SVID Actual shuttle pressure
 >
> .
```

### S2F23 Delete Trace Send

```
<L [5]
 <U2 1>
 <A '000000'>
 <U2 0>
 <U2 1>
 <L
 >
> .
```



**S3F13 Material ID Send**

```
<L [2]
 <B 01>
 <A '090491STD4VAC'>
> .
```

**S2F33 Define Report Send**

```
<L [2]
 <U2 1> * Data ID No. 1.
 <L [1]
 <L [2]
 <U2 1> * Report ID No. 1.
 <L [6]
 <U2 0> * Variable Data ID No. 0.
 <U2 18> * Variable Data ID No. 18.
 <U2 13> * Variable Data ID No. 13.
 <U2 14> * Variable Data ID No. 13.
 <U2 11> * Variable Data ID No. 11.
 <U2 17> * Variable Data ID No. 17.
 >
 >
 >
> .
```

**S2F35 Link Event Send**

```
<L [2]
 <U2 1> * Data ID No. 1.
 <L
 <L [2]
 <U2 4> * Event ID No. 4. [RF ON]
 <L [1]
 <U2 1> * Report ID No. 1.
 >
 >
 >
> .
```

**S2F37 Enable All Events Send**

```
<L [2]
 <BOOLEAN T>
 <L>
> .
```

## Appendix J—Event Report Configuration File Structure

File "CUST??.RPT" contains the defined event report records. The customer ID number will be used to fill the "??" in the file name. For example, the file name will be "CUST99.RPT" for customer ID 99. The structure of the record is as follows:

DATAID, PFCD, CEID, DSID, VID, VID, VID.....

All IDs are in numeric format.

The same CEID may be assigned in more than one record. The Aspen will link them into one report.

If the Aspen cannot find the file or the CEID in the file, the Aspen will search the host-defined report generated by S2F33, S2F35 and S2F37 upon the occurrence of an enabled event.



## Appendix K—Material Handling Diagram

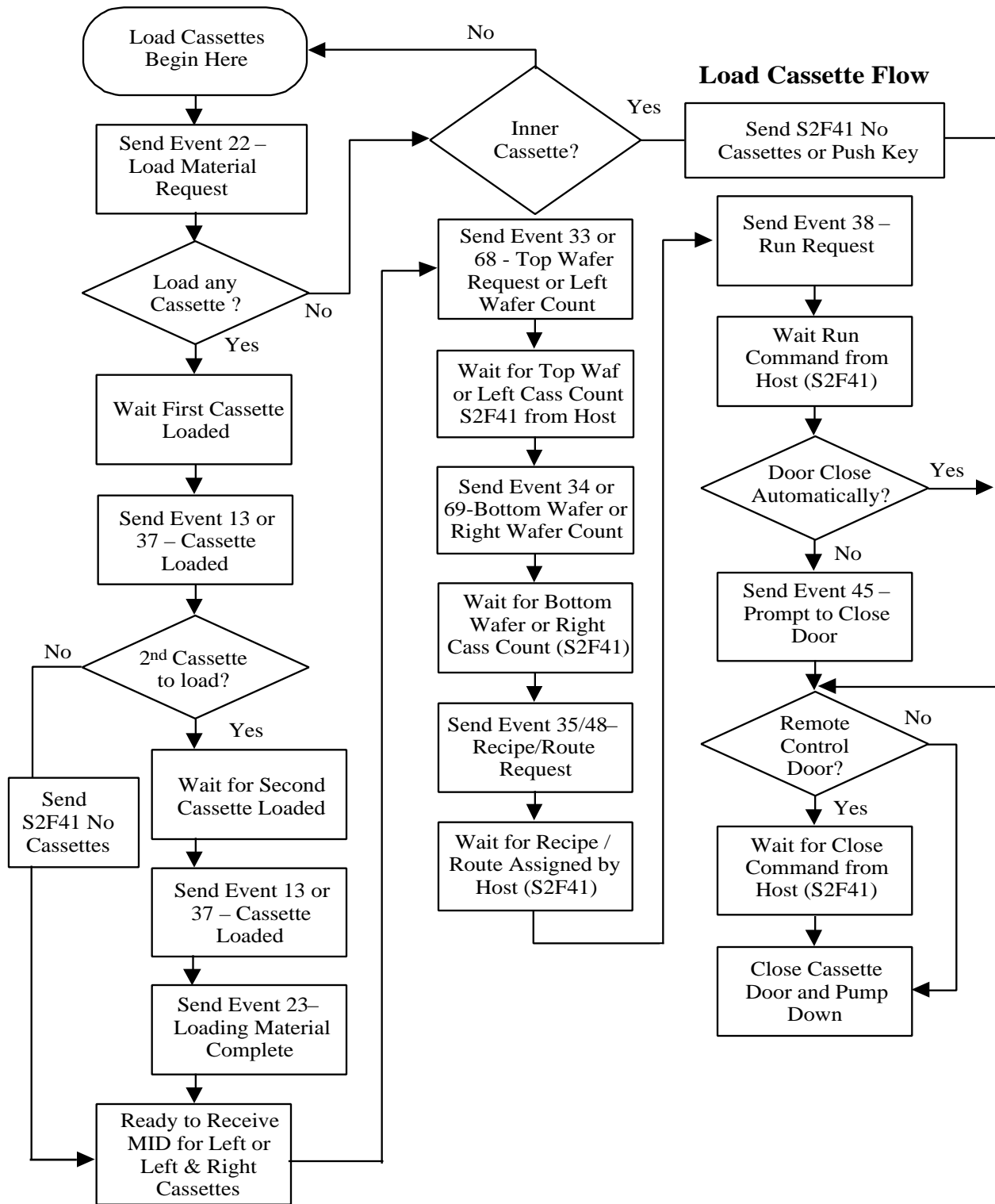

Figure K-1. Load Cassette Software Flow

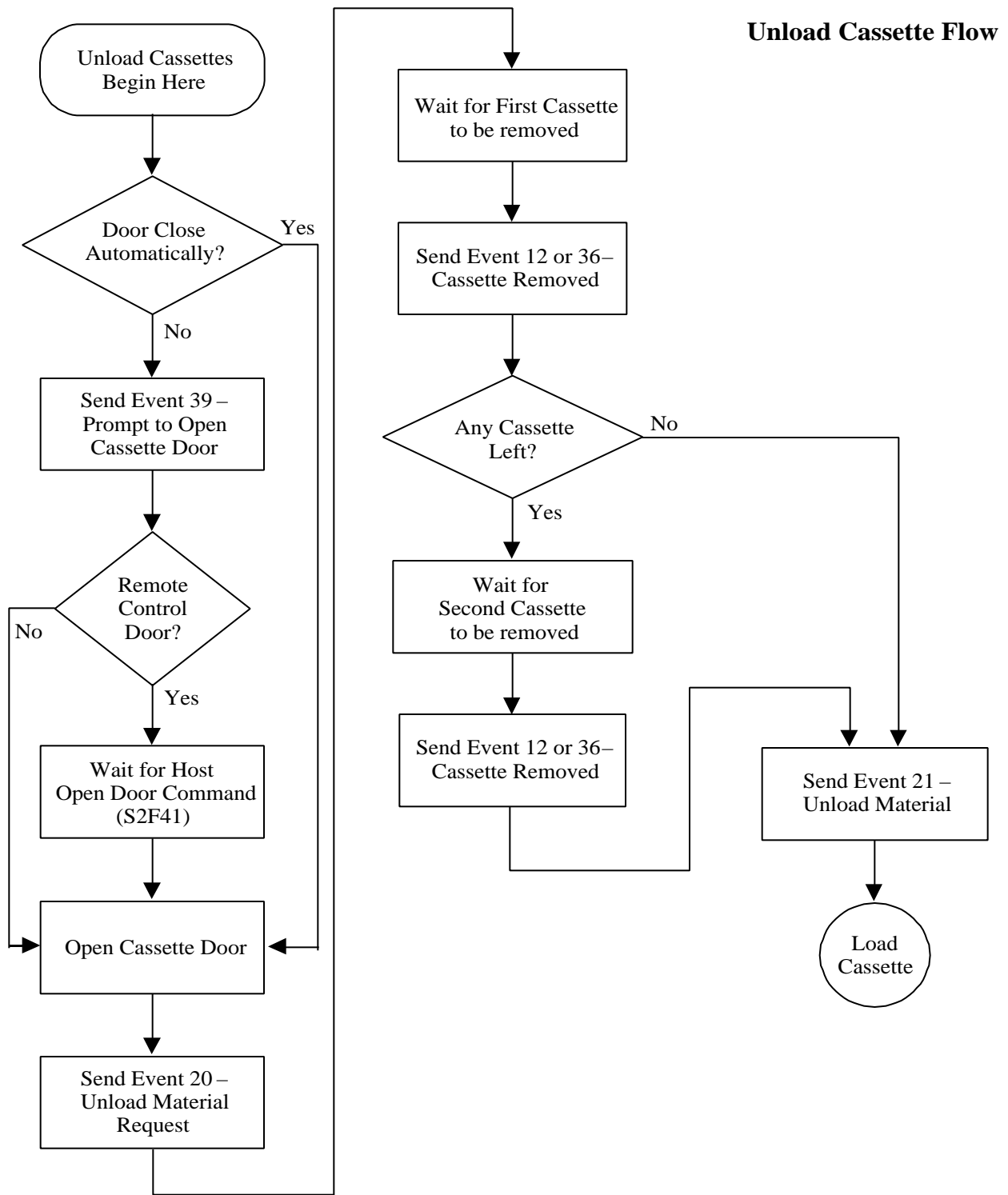

Figure K-2. Unload Cassette Software Flow

## Appendix L—Aspen SECS II Scenarios

### Scenario Semi-Auto Mode / Remote Mode

| Host                                                        | S/F                | Aspen                                            |
|-------------------------------------------------------------|--------------------|--------------------------------------------------|
|                                                             |                    | Power up and Aspen defaults to Engineering Mode. |
|                                                             | S1F1 ←<br>S1F2 →   | On-line check                                    |
| <TIME>                                                      | S2F17 ←<br>S2F18 → | Time request                                     |
| <ACK6>                                                      | S6F11 ←<br>S6F12 → | Mode change <CEID=40>                            |
| <ACK6>                                                      | S6F11 ←<br>S6F12 → | Load request for batch 1<CEID=22>                |
|                                                             |                    | Operator puts cassette on left                   |
| <ACK6>                                                      | S6F11 ←<br>S6F12 → | Load complete on left <CEID=13>                  |
|                                                             |                    | Operator put cassette on right                   |
| <ACK6>                                                      | S6F11 ←<br>S6F12 → | Load complete on right <CEID=37>                 |
| Set lot ID on left <MID>, <PTN>                             | S3F13 →<br>S3F14 ← | <MIDAC>                                          |
| Set lot ID on right <MID>, <PTN>                            | S3F13 →<br>S3F14 ← | <MIDAC>                                          |
| <ACK6>                                                      | S6F11 ←<br>S6F12 → | Top wafer number request <CEID=33>               |
| Send <RCMD>, <CPNAME>, <CPVAL><br>'TOP' 'WAFER' 25          | S2F41 →<br>S2F42 ← | <CMDA>                                           |
| <ACK6>                                                      | S6F11 ←<br>S6F12 → | Bottom wafer number request <CEID=34>            |
| Send <RCMD>, <CPNAME>, <CPVAL><br>'BOTTOM' 'WAFER' 1        | S2F41 →<br>S2F42 ← | <CMDA>                                           |
| <ACK6>                                                      | S6F11 ←<br>S6F12 → | Recipe request <CEID=35>                         |
| Set recipe <RCMD>, <CPNAME>, <CPVAL><br>'RECIPE' 'NUMBER' 2 | S2F41 →<br>S2F42 ← | <CMDA>                                           |
| <ACK6>                                                      | S6F11 ←<br>S6F12 → | Process start request <CEID=38>                  |
| (MIRA) <PTN>, <MIDRA>, <MID><br>1 0 'Test1'                 | S3F11 ←<br>S3F12 → | Material ID request PTN 1                        |
| (MIRA) <PTN>, <MIDRA>, <MID><br>2 0 'Test2'                 | S3F11 ←<br>S3F12 → | Material ID request PTN 2                        |
| Start process <RCMD ><br>'RUN CONTINUOUS'                   | S2F41 →<br>S2F42 ← | <CMDA>                                           |

or, do not  
send this

but, send  
this

| Host                                       | S/F                | Aspen                                  |                         |
|--------------------------------------------|--------------------|----------------------------------------|-------------------------|
|                                            |                    | Close Door                             |                         |
|                                            |                    | Pumpdown                               |                         |
|                                            |                    | Rotate Shuttle                         |                         |
| <ACK6>                                     | S6F11 ←<br>S6F12 → | Process start for batch 1 <CEID=3>     |                         |
|                                            |                    | Processing wafers on batch 1<br>:<br>: |                         |
|                                            |                    | Backfill                               |                         |
|                                            |                    | Open Door                              |                         |
| <ACK6>                                     | S6F11 ←<br>S6F12 → | Load request for batch 2 <CEID=22>     |                         |
|                                            |                    | Operator puts cassette on left         |                         |
| <ACK6>                                     | S6F11 ←<br>S6F12 → | Load complete on left <CEID=13>        |                         |
|                                            |                    | Operator puts cassette on right        |                         |
| <ACK6>                                     | S6F11 ←<br>S6F12 → | Load complete on right <CEID=37>       |                         |
| Set lot ID on left <MID>, <PTN>            | S3F13 →<br>S3F14 ← | <MIDAC>                                | or, do not<br>send this |
| Set lot ID on right <MID>, <PTN>           | S3F13 →<br>S3F14 ← | <MIDAC>                                |                         |
| <ACK6>                                     | S6F11 ←<br>S6F12 → | Top wafer number request <CEID=33>     |                         |
| Set top wafer <RCMD>, <CPNAME>, <CPVAL>    | S2F41 →<br>S2F42 ← | <CMDA>                                 |                         |
| <ACK6>                                     | S6F11 ←<br>S6F12 → | Bottom wafer number request <CEID=34>  |                         |
| Set bottom wafer <RCMD>, <CPNAME>, <CPVAL> | S2F41 →<br>S2F42 ← | <CMDA>                                 |                         |
| <ACK6>                                     | S6F11 ←<br>S6F12 → | Recipe request <CEID=35>               |                         |
| Set Route/Recipe <RCMD>, <CPNAME>, <CPVAL> | S2F41 →<br>S2F42 ← | <CMDA>                                 |                         |
| <ACK6>                                     | S6F11 ←<br>S6F12 → | Process start request <CEID=38>        |                         |
| (MIRA) <PTN>, <MIDRA>, <MID>               | S3F11 ←<br>S3F12 → | Material ID request PTN 1              | but, send<br>this       |
| (MIRA) <PTN>, <MIDRA>, <MID>               | S3F11 ←<br>S3F12 → | Material ID request PTN 2              |                         |

| Host                     | S/F                | Aspen                                   |
|--------------------------|--------------------|-----------------------------------------|
| Start process <RCMD >    | S2F41 →<br>S2F42 ← | <CMDA>                                  |
|                          |                    | Close Door                              |
|                          |                    | Pumpdown                                |
|                          |                    | ::<br>Processing wafers on Batch 1<br>: |
| <ACK6>                   | S6F11 ←<br>S6F12 → | Process complete on Batch 1 <CEID=6>    |
|                          |                    | Rotate Shuttle                          |
| <ACK6>                   | S6F11 ←<br>S6F12 → | Process start for Batch 2 <CEID=3>      |
|                          |                    | :<br>Processing wafers on Batch 2<br>:  |
|                          |                    | Backfill                                |
|                          |                    | Open Door                               |
| <ACK6>                   | S6F11 ←<br>S6F12 → | Unload request for Batch 1 <CEID=20>    |
|                          |                    | Operator removes the cassette on left   |
| <ACK6>                   | S6F11 ←<br>S6F12 → | Unload complete on left <CEID=12>       |
|                          |                    | Operator removes the cassette on right  |
| <ACK6>                   | S6F11 ←<br>S6F12 → | Unload complete on right <CEID=36>      |
| <ACK6>                   | S6F11 ←<br>S6F12 → | Load request for next batch <CEID=22>   |
| No more cassettes <RCMD> | S2F41 →<br>S2F42 ← | <CMDA>                                  |
|                          |                    | Close Door                              |
|                          |                    | Pumpdown                                |
|                          |                    | :<br>Processing wafers on Batch 2<br>:  |
| <ACK6>                   | S6F11 ←<br>S6F12 → | Process complete on Batch 2 <CEID=6>    |
|                          |                    | Rotate Shuttle                          |
|                          |                    | Backfill                                |
|                          |                    | Open Door                               |
| <ACK6>                   | S6F11 ←<br>S6F12 → | Unload request for Batch 2 <CEID=20>    |



| Host   | S/F                | Aspen                                  |
|--------|--------------------|----------------------------------------|
|        |                    | Operator removes the cassette on left  |
| <ACK6> | S6F11 ←<br>S6F12 → | Unload complete on left <CEID=12>      |
|        |                    | Operator removes the cassette on right |
| <ACK6> | S6F11 ←<br>S6F12 → | Unload complete on right <CEID=36>     |

**Scenario Full-Auto Mode/AGV Mode**

| Host                                   | S/F                                                                                          | Aspen                                                                                                                                                                                                                                                                                                                                                                                                                                                                                                  |              |                                                                                              |                                       |                       |  |  |
|----------------------------------------|----------------------------------------------------------------------------------------------|--------------------------------------------------------------------------------------------------------------------------------------------------------------------------------------------------------------------------------------------------------------------------------------------------------------------------------------------------------------------------------------------------------------------------------------------------------------------------------------------------------|--------------|----------------------------------------------------------------------------------------------|---------------------------------------|-----------------------|--|--|
|                                        |                                                                                              | Power up and Aspen defaults to Engineering Mode.                                                                                                                                                                                                                                                                                                                                                                                                                                                       |              |                                                                                              |                                       |                       |  |  |
|                                        | S1F1 ←<br>S1F2 →                                                                             | On-line check                                                                                                                                                                                                                                                                                                                                                                                                                                                                                          |              |                                                                                              |                                       |                       |  |  |
| <TIME>                                 | S2F17 ←<br>S2F18 →                                                                           | Time request                                                                                                                                                                                                                                                                                                                                                                                                                                                                                           |              |                                                                                              |                                       |                       |  |  |
| <ACK6>                                 | S6F11 ←<br>S6F12 →                                                                           | Mode change <CEID=40>                                                                                                                                                                                                                                                                                                                                                                                                                                                                                  |              |                                                                                              |                                       |                       |  |  |
| <ACK6>                                 | S6F11 ←<br>S6F12 →                                                                           | AGV load request on left <CEID=97><br>(Batch 1)                                                                                                                                                                                                                                                                                                                                                                                                                                                        |              |                                                                                              |                                       |                       |  |  |
| <ACK6>                                 | S6F11 ←<br>S6F12 →                                                                           | AGV load request on right <CEID=98><br>(Batch 1)                                                                                                                                                                                                                                                                                                                                                                                                                                                       |              |                                                                                              |                                       |                       |  |  |
| Host commands the AGV to move to Aspen |                                                                                              |                                                                                                                                                                                                                                                                                                                                                                                                                                                                                                        |              |                                                                                              |                                       |                       |  |  |
|                                        |                                                                                              | <table border="1"> <tr> <td><b>Aspen</b></td> <td>                     CS_0 ←<br/>                     CS_1 ←<br/>                     CS_2 ←<br/>                     VALID ←<br/>                     L_REQ →<br/>                     TR_REQ ←<br/>                     READY →<br/>                     BUSY ←<br/>                     COMPT ←                 </td> <td><b>AGV</b><br/>Left cassette transfer</td> </tr> <tr> <td>Left cassette loaded</td> <td></td> <td></td> </tr> </table>   | <b>Aspen</b> | CS_0 ←<br>CS_1 ←<br>CS_2 ←<br>VALID ←<br>L_REQ →<br>TR_REQ ←<br>READY →<br>BUSY ←<br>COMPT ← | <b>AGV</b><br>Left cassette transfer  | Left cassette loaded  |  |  |
| <b>Aspen</b>                           | CS_0 ←<br>CS_1 ←<br>CS_2 ←<br>VALID ←<br>L_REQ →<br>TR_REQ ←<br>READY →<br>BUSY ←<br>COMPT ← | <b>AGV</b><br>Left cassette transfer                                                                                                                                                                                                                                                                                                                                                                                                                                                                   |              |                                                                                              |                                       |                       |  |  |
| Left cassette loaded                   |                                                                                              |                                                                                                                                                                                                                                                                                                                                                                                                                                                                                                        |              |                                                                                              |                                       |                       |  |  |
| <ACK6>                                 | S6F11 ←<br>S6F12 →                                                                           | AGV load complete on left <CEID=93>                                                                                                                                                                                                                                                                                                                                                                                                                                                                    |              |                                                                                              |                                       |                       |  |  |
|                                        |                                                                                              | <table border="1"> <tr> <td><b>Aspen</b></td> <td>                     CS_0 ←<br/>                     CS_1 ←<br/>                     CS_2 ←<br/>                     VALID ←<br/>                     L_REQ →<br/>                     TR_REQ ←<br/>                     READY →<br/>                     BUSY ←<br/>                     COMPT ←                 </td> <td><b>AGV</b><br/>Right cassette transfer</td> </tr> <tr> <td>Right cassette loaded</td> <td></td> <td></td> </tr> </table> | <b>Aspen</b> | CS_0 ←<br>CS_1 ←<br>CS_2 ←<br>VALID ←<br>L_REQ →<br>TR_REQ ←<br>READY →<br>BUSY ←<br>COMPT ← | <b>AGV</b><br>Right cassette transfer | Right cassette loaded |  |  |
| <b>Aspen</b>                           | CS_0 ←<br>CS_1 ←<br>CS_2 ←<br>VALID ←<br>L_REQ →<br>TR_REQ ←<br>READY →<br>BUSY ←<br>COMPT ← | <b>AGV</b><br>Right cassette transfer                                                                                                                                                                                                                                                                                                                                                                                                                                                                  |              |                                                                                              |                                       |                       |  |  |
| Right cassette loaded                  |                                                                                              |                                                                                                                                                                                                                                                                                                                                                                                                                                                                                                        |              |                                                                                              |                                       |                       |  |  |
| <ACK6>                                 | S6F11 ←<br>S6F12 →                                                                           | AGV load complete on right <CEID=94>                                                                                                                                                                                                                                                                                                                                                                                                                                                                   |              |                                                                                              |                                       |                       |  |  |
| Set lot ID on left <MID>, <PTN>        | S3F13 →<br>S3F14 ←                                                                           | <MIDAC>                                                                                                                                                                                                                                                                                                                                                                                                                                                                                                |              |                                                                                              |                                       |                       |  |  |
| Set lot ID on right <MID>, <PTN>       | S3F13 →<br>S3F14 ←                                                                           | <MIDAC>                                                                                                                                                                                                                                                                                                                                                                                                                                                                                                |              |                                                                                              |                                       |                       |  |  |
| <ACK6>                                 | S6F11 ←<br>S6F12 →                                                                           | Top wafer number request <CEID=33>                                                                                                                                                                                                                                                                                                                                                                                                                                                                     |              |                                                                                              |                                       |                       |  |  |

| Host                                                                                         | S/F                    | Aspen                                                                                                                                                                                                                                                                                                            |       |     |                                                                                              |                        |                      |  |
|----------------------------------------------------------------------------------------------|------------------------|------------------------------------------------------------------------------------------------------------------------------------------------------------------------------------------------------------------------------------------------------------------------------------------------------------------|-------|-----|----------------------------------------------------------------------------------------------|------------------------|----------------------|--|
| Set top wafer <RCMD>, <CPNAME>, <CPVAL>                                                      | S2F41 →<br>S2F42 ←     | <CMDA>                                                                                                                                                                                                                                                                                                           |       |     |                                                                                              |                        |                      |  |
| <ACK6>                                                                                       | S6F11 ←<br>S6F12 →     | Bottom wafer number request <CEID=34>                                                                                                                                                                                                                                                                            |       |     |                                                                                              |                        |                      |  |
| Set bottom wafer <RCMD>, <CPNAME>, <CPVAL>                                                   | S2F41 →<br>S2F42 ←     | <CMDA>                                                                                                                                                                                                                                                                                                           |       |     |                                                                                              |                        |                      |  |
| <ACK6>                                                                                       | S6F11 ←<br>S6F12 →     | Recipe request <CEID=35>                                                                                                                                                                                                                                                                                         |       |     |                                                                                              |                        |                      |  |
| Set recipe <RCMD>, <CPNAME>, <CPVAL>                                                         | S2F41 →<br>S2F42 ←     | <CMDA>                                                                                                                                                                                                                                                                                                           |       |     |                                                                                              |                        |                      |  |
| <ACK6>                                                                                       | S6F11 ←<br>S6F12 →     | Process start request <CEID=38>                                                                                                                                                                                                                                                                                  |       |     |                                                                                              |                        |                      |  |
| Start process <RCMD>                                                                         | S2F41 →<br>S2F42 ←     | <CMDA>                                                                                                                                                                                                                                                                                                           |       |     |                                                                                              |                        |                      |  |
|                                                                                              |                        | Close Door                                                                                                                                                                                                                                                                                                       |       |     |                                                                                              |                        |                      |  |
|                                                                                              |                        | Pumpdown                                                                                                                                                                                                                                                                                                         |       |     |                                                                                              |                        |                      |  |
|                                                                                              |                        | Rotate Shuttle                                                                                                                                                                                                                                                                                                   |       |     |                                                                                              |                        |                      |  |
| <ACK6>                                                                                       | S6F11 ←<br>S6F12 →     | Process start on Batch 1 <CEID=3>                                                                                                                                                                                                                                                                                |       |     |                                                                                              |                        |                      |  |
|                                                                                              |                        | :<br>Processing wafers on Batch 1<br>:                                                                                                                                                                                                                                                                           |       |     |                                                                                              |                        |                      |  |
|                                                                                              |                        | Backfill                                                                                                                                                                                                                                                                                                         |       |     |                                                                                              |                        |                      |  |
|                                                                                              |                        | Open Door                                                                                                                                                                                                                                                                                                        |       |     |                                                                                              |                        |                      |  |
| <ACK6>                                                                                       | S6F11 ←<br>S6F12 →     | AGV load request on left <CEID=97><br>(Batch 2)                                                                                                                                                                                                                                                                  |       |     |                                                                                              |                        |                      |  |
| <ACK6>                                                                                       | S6F11 ←<br>S6F12 →     | AGV load request on right <CEID=98><br>(Batch 2)                                                                                                                                                                                                                                                                 |       |     |                                                                                              |                        |                      |  |
| Host commands the AGV to move to Aspen                                                       |                        |                                                                                                                                                                                                                                                                                                                  |       |     |                                                                                              |                        |                      |  |
|                                                                                              |                        | <table border="1"> <thead> <tr> <th>Aspen</th> <th>AGV</th> </tr> </thead> <tbody> <tr> <td>CS_0 ←<br/>CS_1 ←<br/>CS_2 ←<br/>VALID ←<br/>L_REQ →<br/>TR_REQ ←<br/>READY →<br/>BUSY ←<br/>COMPT ←</td> <td>Left cassette transfer</td> </tr> <tr> <td>Left cassette loaded</td> <td></td> </tr> </tbody> </table> | Aspen | AGV | CS_0 ←<br>CS_1 ←<br>CS_2 ←<br>VALID ←<br>L_REQ →<br>TR_REQ ←<br>READY →<br>BUSY ←<br>COMPT ← | Left cassette transfer | Left cassette loaded |  |
| Aspen                                                                                        | AGV                    |                                                                                                                                                                                                                                                                                                                  |       |     |                                                                                              |                        |                      |  |
| CS_0 ←<br>CS_1 ←<br>CS_2 ←<br>VALID ←<br>L_REQ →<br>TR_REQ ←<br>READY →<br>BUSY ←<br>COMPT ← | Left cassette transfer |                                                                                                                                                                                                                                                                                                                  |       |     |                                                                                              |                        |                      |  |
| Left cassette loaded                                                                         |                        |                                                                                                                                                                                                                                                                                                                  |       |     |                                                                                              |                        |                      |  |
| <ACK6>                                                                                       | S6F11 ←<br>S6F12 →     | AGV load complete on left <CEID=93>                                                                                                                                                                                                                                                                              |       |     |                                                                                              |                        |                      |  |

| Host                                      | S/F                | Aspen                                     |                                                                                                                                           |
|-------------------------------------------|--------------------|-------------------------------------------|-------------------------------------------------------------------------------------------------------------------------------------------|
|                                           |                    | <u>Aspen</u><br><br>Right cassette loaded | <u>AGV</u><br>Right cassette transfer<br><br>CS_0 ←<br>CS_1 ←<br>CS_2 ←<br>VALID ←<br>L_REQ →<br>TR_REQ ←<br>READY →<br>BUSY ←<br>COMPT ← |
| <ACK6>                                    | S6F11 ←<br>S6F12 → | AGV load complete on right <CEID=94>      |                                                                                                                                           |
| Set lot ID on left <MID>, <PTN>           | S3F13 →<br>S3F14 ← | <MIDAC>                                   |                                                                                                                                           |
| Set lot ID on right <MID>, <PTN>          | S3F13 →<br>S3F14 ← | <MIDAC>                                   |                                                                                                                                           |
| <ACK6>                                    | S6F11 ←<br>S6F12 → | Top wafer number request <CEID=33>        |                                                                                                                                           |
| Set top wafer <RCMD>, <CPNAME>, <CPVAL>   | S2F41 →<br>S2F42 ← | <CMDA>                                    |                                                                                                                                           |
| <ACK6>                                    | S6F11 ←<br>S6F12 → | Bottom wafer number request <CEID=34>     |                                                                                                                                           |
| Set bottom wafer<RCMD>, <CPNAME>, <CPVAL> | S2F41 →<br>S2F42 ← | <CMDA>                                    |                                                                                                                                           |
| <ACK6>                                    | S6F11 ←<br>S6F12 → | Recipe request <CEID=35>                  |                                                                                                                                           |
| Set recipe <RCMD>, <CPNAME>, <CPVAL>      | S2F41 →<br>S2F42 ← | <CMDA>                                    |                                                                                                                                           |
| <ACK6>                                    | S6F11 ←<br>S6F12 → | Process start request <CEID=38>           |                                                                                                                                           |
| Start process <RCMD >                     | S2F41 →<br>S2F42 ← | <CMDA>                                    |                                                                                                                                           |
|                                           |                    | Close Door                                |                                                                                                                                           |
|                                           |                    | Pumpdown                                  |                                                                                                                                           |
|                                           |                    | :<br>Processing wafers on Batch 1<br>:    |                                                                                                                                           |
| <ACK6>                                    | S6F11 ←<br>S6F12 → | Process complete on Batch 1 <CEID=6>      |                                                                                                                                           |
|                                           |                    | Rotate Shuttle                            |                                                                                                                                           |
| <ACK6>                                    | S6F11 ←<br>S6F12 → | Process start for batch 2 <CEID=3>        |                                                                                                                                           |

| Host                                   | S/F                | Aspen                                               |                                                                                               |                                       |
|----------------------------------------|--------------------|-----------------------------------------------------|-----------------------------------------------------------------------------------------------|---------------------------------------|
|                                        |                    | : Processing wafers on Batch 2<br>:                 |                                                                                               |                                       |
|                                        |                    | Backfill                                            |                                                                                               |                                       |
|                                        |                    | Open Door                                           |                                                                                               |                                       |
| <ACK6>                                 | S6F11 ←<br>S6F12 → | AGV unload request on left <CEID=95><br>(Batch 1)   |                                                                                               |                                       |
| <ACK6>                                 | S6F11 ←<br>S6F12 → | AGV unload request on right <CEID=96><br>(Batch 1)  |                                                                                               |                                       |
| Host commands the AGV to move to Aspen |                    |                                                     |                                                                                               |                                       |
|                                        |                    | <u>Aspen</u><br><br>Left cassette removed           | CS_0 ←<br>CS_1 ←<br>CS_2 ←<br>VALID ←<br>UN_REQ →<br>TR_REQ ←<br>READY →<br>BUSY ←<br>COMPT ← | <u>AGV</u><br>Left cassette transfer  |
| <ACK6>                                 | S6F11 ←<br>S6F12 → | AGV unload complete on left <CEID=91>               |                                                                                               |                                       |
|                                        |                    | <u>Aspen</u><br><br>Right cassette removed          | CS_0 ←<br>CS_1 ←<br>CS_2 ←<br>VALID ←<br>UN_REQ →<br>TR_REQ ←<br>READY →<br>BUSY ←<br>COMPT ← | <u>AGV</u><br>Right cassette transfer |
| <ACK6>                                 | S6F11 ←<br>S6F12 → | AGV unload complete on right <CEID=92>              |                                                                                               |                                       |
| <ACK6>                                 | S6F11 ←<br>S6F12 → | AGV load request on left <CEID=97><br>(Next Batch)  |                                                                                               |                                       |
| <ACK6>                                 | S6F11 ←<br>S6F12 → | AGV load request on right <CEID=98><br>(Next batch) |                                                                                               |                                       |
| No more cassettes <RCMD>               | S2F41 →<br>S2F42 ← | <CMDA>                                              |                                                                                               |                                       |
|                                        |                    | Close Door                                          |                                                                                               |                                       |
|                                        |                    | Pumpdown                                            |                                                                                               |                                       |

| Host                                   | S/F                | Aspen                                              |                                                                                               |                                       |
|----------------------------------------|--------------------|----------------------------------------------------|-----------------------------------------------------------------------------------------------|---------------------------------------|
|                                        |                    | : Processing wafers on Batch 2<br>:                |                                                                                               |                                       |
| <ACK6>                                 | S6F11 ←<br>S6F12 → | Process complete on Batch 2 <CEID=6>               |                                                                                               |                                       |
|                                        |                    | Rotate Shuttle                                     |                                                                                               |                                       |
|                                        |                    | Backfill                                           |                                                                                               |                                       |
|                                        |                    | Open Door                                          |                                                                                               |                                       |
| <ACK6>                                 | S6F11 ←<br>S6F12 → | AGV unload request on left <CEID=95><br>(Batch 2)  |                                                                                               |                                       |
| <ACK6>                                 | S6F11 ←<br>S6F12 → | AGV unload request on right <CEID=96><br>(Batch 2) |                                                                                               |                                       |
| Host commands the AGV to move to Aspen |                    |                                                    |                                                                                               |                                       |
|                                        |                    | <b>Aspen</b><br><br>Left cassette removed          | CS_0 ←<br>CS_1 ←<br>CS_2 ←<br>VALID ←<br>UN_REQ →<br>TR_REQ ←<br>READY →<br>BUSY ←<br>COMPT ← | <b>AGV</b><br>Left cassette transfer  |
| <ACK6>                                 | S6F11 ←<br>S6F12 → | AGV unload complete on left <CEID=91>              |                                                                                               |                                       |
|                                        |                    | <b>Aspen</b><br><br>Right cassette remove          | CS_0 ←<br>CS_1 ←<br>CS_2 ←<br>VALID ←<br>UN_REQ →<br>TR_REQ ←<br>READY →<br>BUSY ←<br>COMPT ← | <b>AGV</b><br>Right cassette transfer |
| <ACK6>                                 | S6F11 ←<br>S6F12 → | AGV unload complete on right <CEID=92>             |                                                                                               |                                       |



## Appendix M—SML File

---

**Note** The following is a transcript of the *strip.sml* file for the Aspen Strip System. The actual *strip.sml* file can be obtained from Mattson Technology by sending an email request to [plasmaproductstechsupport@mattson.com](mailto:plasmaproductstechsupport@mattson.com). It is also supplied on the Aspen II Strip Electronic Documentation CDROM.

---

---

**Note** Lines beginning with an asterisk (\*) in this file are comments that should not be compiled when the file is used.

---

```

** Mattson Technology Incorporated
** Copyright (c) 1997. All Rights Reserved
**
** DESCRIPTION: STRIP SML FILE
** Version 1.3
**
** Modification Log:
** DATE INITIALS VERSION DESCRIPTION
** 06/18/97 CRB1 1.3 Changed the header.
** 05/13/97 CRB1 1.2 Added S1F15 New Equipment Constant Send (ECS)
** Messages, Added S2F65 Reset Spooling Streams
** and Functions testing, Added S6F65 Request
** Spooled Data (RSD), Added S2F41 'WHITE' and
** 'BLUE' light commands, Made an old and a new
** S2F37 Enable Event Reports for older code testing
** 05/11/97 CRB1 1.1 Added S1F9 Material Transfer Status Request (TSR)
** Added S1F11 Status Variable Namelist (SVNR)
** Added S2F13 Zero length for all Equipment Constants
** 04/17/97 CRB1 1.0 Added Asyst SMIF 2200 LPT robot commands to S2F41
** 'LOCK POD'
** 'UNLOCK POD'
** 'LOAD CASSETTE'
** 'UNLOAD CASSETTE'
** Alarm Event # 16, 'SMIF LOADER ERROR'
** CEID's
** 100 - Left Pod put on
** 101 - Right Pod put on
** 102 - Load Left Cassette request
** 103 - Load Right Cassette request
** 104 - Loader load left complete
** 105 - Loader load right complete
** 106 - Loader unload left request
** 107 - Loader unload right request
** 108 - Loader unload left complete
** 109 - Loader unload right complete
```



## Appendix M—SML File

---

```
** 110 - Loader left ready to remove
** 111 - Loader right ready to remove
** 112 - Loader left removed
** 113 - Loader right removed
** 114 - Loader left comm error
** 115 - Loader right comm error
**

* Abort Transaction

S1F0:S1F0 .

* HANDSHAKE COMMAND

S1F1:'S1F1' W.

'S1F2'.

* Status Request

S1F3L0: S1F3 W
 <L [0]
 >.

S1F3AspenMode: S1F3 W
 <L
 <U2 25> * Equipment Mode
 >.

S1F3Door:'S1F3' W
 <L
 <U2 29> * ASPEN Cass Door Status
 >.

S1F3CassStatus:'S1F3' W
 <L
 <U2 27> * Left Outer Cassette Nest Status
 <U2 33> * right outer cassette status
 >.
```

S1F3ChamberStatus:'S1F3' W

```
<L
<U2 25> * ASPEN Equipment Mode
<U2 27> * Left Outer Cassette Nest Status
<U2 33> * right outer cassette status
<U2 44> * SIDE CHAMBER status
<U2 76> * BACK CHAMBER status
>.
```

S1F3PortStatusLeft:'S1F3' W

```
<L
<U2 27> * Left Outer Cassette Nest Status
>.
```

S1F3PortStatusRight:'S1F3' W

```
<L
<U2 33> * right outer cassette status
>.
```

S1F3All:'S1F3' W

```
<L [43]
<U2 0> *Date & Time
<U2 1> *Processing Recipe Name
<U2 2> *Processing Recipe step.
<U2 3> *RF Power setting
<U2 4> *Proc Press setting
<U2 5> *RF time setting
<U2 6> *Gas 1 Flow setting
<U2 7> *Gas 2 Flow setting
<U2 8> *Gas 3 Flow setting
<U2 9> *Proc Delay Time
<U2 10> *Temperature setting
<U2 11> *RF Fwd Power Actual
<U2 12> *RF Elapse Time Act.
<U2 13> *Proc Press Actual
<U2 14> *Gas 1 Flow Actual
<U2 15> *Gas 2 Flow Actual
<U2 16> *Gas 3 Flow Actual
<U2 17> *Temperature Actual
<U2 18> *Current Wafer No.
<U2 19> *Load Lock Press.
<U2 20> *Shuttle Press.
<U2 21> *Left Outer Material ID Nest[0]
<U2 22> *Right Outer Material ID Nest[1]
<U2 23> *Left Inner Material ID Nest[0]
<U2 24> *Right Inner Material ID Nest[1]
```

## Appendix M—SML File

---

```
<U2 25> *ASPEN Equipment Mode
<U2 26> *ASPEN Equipment Status
<U2 27> *Left Outer Cassette Nest Status
<U2 28> *Left Inner Cassette Nest Status
<U2 29> *Cassette Door Status
<U2 30> *RF Rev Power Actual
<U2 31> *RF Rev Power Actual
<U2 32> *Right Wafer # in Chamber
<U2 33> * right outer cassette status
<U2 34> * right inner cassette status
<U2 49> *Chamber location of preceding
<U2 100> *Total Wafers
<U2 101> *Pin Search Data
<U2 200> *Spool Count Actual
<U2 201> *Spool Count Total
<U2 202> *Spool Start Time
<U2 203> *Spool Full Time
<U2 204> *Spool State
>.
```

```

* STATUS REQUEST

S1F3SecsStatus:'S1F3' W
 <L
 <U2 0> *Date & Time
 <U2 5> *RF time setting
 <U2 9> *Proc Delay Time
 <U2 12> *RF Elapse Time Act.
 <U2 31> *end point
 >.
```

```

* HEX OPTION REQUEST

S1F3HexOption:'S1F3' W
 <L
 <U2 80> *HEX Option
 >.
```

```

* CIDs REQUEST

S1F3Cid1:'S1F3' W
 <L
 <U2 91> *CID 1
```

```
>.

S1F3Cid2:'S1F3' W
 <L
 <U2 92> *CID 2
 >.

S1F3Cid3:'S1F3' W
 <L
 <U2 93> *CID 3
 >.

S1F3Cid4:'S1F3' W
 <L
 <U2 94> *CID 4
 >.

S1F3CidAll:'S1F3' W
 <L
 <U2 91> *CID 1
 <U2 92> *CID 2
 <U2 93> *CID 3
 <U2 94> *CID 4
 >.

S1F3Mid1:'S1F3' W
 <L
 <U2 21> *MID 1
 >.

S1F3Mid2:'S1F3' W
 <L
 <U2 22> *MID 2
 >.

S1F3Mid3:'S1F3' W
 <L
 <U2 23> *MID 3
 >.

S1F3Mid4:'S1F3' W
 <L
 <U2 24> *MID 4
 >.

S1F3MidAll:'S1F3' W
```

## Appendix M—SML File

---

```
<L
 <U2 21> *MID 1
 <U2 22> *MID 2
 <U2 23> *MID 3
 <U2 24> *MID 4
>.

* MATERIAL TRANSFER STATUS DATA (TSD)

* Host requests a status report for the material transfer ports.
* Aspen is equipped with 2 ports, inside (the first report) and
* outside (the second report).
*
S1F9MtrlXferReq:'S1F9' W
 <L [0]
 >.

* STATUS VARIABLE NAME LIST (SVNR)

* A request to Aspen to identify certain status variables.
*
S1F11StatVairNamLst:'S1F11' W
 <L
 <U2 0> *Date and Time
 <U2 1> *Processing Recipe Name
 <U2 2> *Processing Recipe Step Number
 <U2 3> *RF Power Setting
 <U2 4> *Process Pressure Setting
 >.

* ESTAB.COMM.REQUEST

S1F13CommReq:'S1F13' W
 <L [0]
 >.
'S1F14'
 <L [0]
 >.

* ON-LINE OFF LINE .REQUEST

S1F15ReqOFFLine:'S1F15' W.
```

S1F17ReqONLine:'S1F17' W.

```

* Abort Transaction

S2F0:S2F0 .
```

```

* Equipment Constant Request

S2F13AllZero:'S2F13' W
 <L [0]
 >.
```

```
S2F13AllList:'S2F13' W
 <L[13]
 <U2 0> *Establish Communication timeout
 <U2 1> *Set Event Report
 <U2 2> *t1 stuck sender timeout
 <U2 3> *t2 stuck receiver timeout
 <U2 4> *t3 send incomplete timeout
 <U2 5> *Enable/disable static event report 1-16
 <U2 6> *Enable/disable static event report 17-32
 <U2 7> *Set Establish Communication message
 <U2 8> *Set spool overwrite flag
 <U2 9> *Set Max spool transmit
 <U2 10> *Set GEM flag enable
 <U2 11> *Enable/disable static event report 33-48
 <U2 12> *Enable/disable static event report 49-64
 >.
```

```

* New Equipment Constant

S2F15All:'S2F15' W
 <L [13]
 <L [2]
 <U2 0> *Establish Communication
 <U2 60> *Default=60 1->300
 >

 <L [2]
 <U2 1> *Event Report
 <BOOLEAN F> *Set excluded annotation
 >
```

## Appendix M—SML File

---

```
<L [2]
 <U2 2> *S4F9 t1 sender timeout
 <U2 10> *Default=10 1->3000
 >

<L [2]
 <U2 3> *S4F11 t2 receiver timeout
 <U2 60> *Default=60
 >

<L [2]
 <U2 4> *S4F13 t3 incomplete timeout
 <U2 60> *Default=60
 >

<L [2]
 <U2 5> *Disable Static event reports
 <U2 0> *1 to 16
 >

<L [2]
 <U2 6> *Disable Static event report
 <U2 0> *17 to 30
 >

<L [2]
 <U2 7> *Set Establish Communication OFF
 <BOOLEAN F> *Not use S1F13
 >

<L [2]
 <U2 8> *Set spool overwrite flag
 <BOOLEAN F> *
 >

<L [2]
 <U2 9> *Set Max spool transmit message value
 <U2 1> *Default=250
 >

<L [2]
 <U2 10> *Set GEM flag OFF
 <BOOLEAN F> *Not use S5F73
 >

<L [2]
```

```

 <U2 11> *Disable Static event reports
 <U2 0> *33 to 48
 >

 <L [2]
 <U2 12> *Disable Static event report
 <U2 0> *49 to 64
 >
>.

* Establish Communications time-out

S2F15CommTime1Sec:'S2F15' W
 <L [1]
 <L [2]
 <U2 0> *Establish Communications time-out
 <U2 1> *Set time-out to 1 sec
 >
>.

S2F15CommTime60Sec:'S2F15' W
 <L [1]
 <L [2]
 <U2 0> *Establish Communications time-out
 <U2 60> *Set time-out to 60 sec
 >
>.

* Included annotation event report

S2F15Annotated:'S2F15' W
 <L [1]
 <L [2]
 <U2 1> *Event Report
 <BOOLEAN T> *Set included annotation
 >
>.

* Excluded annotation event report

S2F15NotAnnotated:'S2F15' W
 <L [1]

```



## Appendix M—SML File

---

```

 <L [2]
 <U2 1> *Event Report
 <BOOLEAN F> *Set excluded
 >
 >.

* Spool Overwrite Flag

S2F15SpoolOWOn:'S2F15' W
 <L [1]
 <L [2]
 <U2 8> *Set Spool Overwrite flag ON
 <BOOLEAN T>
 >
 >.

S2F15SpoolOWOff:'S2F15' W
 <L [1]
 <L [2]
 <U2 8> *Set Spool Overwrite flag OFF
 <BOOLEAN F>
 >
 >.

* Max Spool Transmit

S2F15SpoolXmit1:'S2F15' W
 <L [1]
 <L [2]
 <U2 9> *Set Spool Xmit = 1 Message
 <U2 1>
 >
 >.

S2F15SpoolXmit5:'S2F15' W
 <L [1]
 <L [2]
 <U2 9> *Set Spool Xmit = 5 Message
 <U2 5>
 >
 >.

S2F15SpoolXmit250:'S2F15' W
 <L [1]
```

```

 <L [2]
 <U2 9> *Set Spool Xmit = 250 Message
 <U2 250>
 >
 >.

```

```

S2F15SpoolXmit999:'S2F15' W
 <L [1]
 <L [2]
 <U2 9> *Set Spool Xmit = 999 Message
 <U2 999>
 >
 >.

```

```

* GEM flag on

S2F15GemOn:'S2F15' W
 <L [1]
 <L [2]
 <U2 10> *Set GEM flag ON
 <BOOLEAN T>
 >
 >.

```

```

* GEM flag off

S2F15GemOff:'S2F15' W
 <L [1]
 <L [2]
 <U2 10> *Set GEM flag OFF
 <BOOLEAN F>
 >
 >.

```

```

* Establish communication on

S2F15s1f13On:'S2F15' W
 <L [1]
 <L [2]
 <U2 7> *Set Establish Communication ON
 <BOOLEAN T> *
 >
 >.

```

## Appendix M—SML File

---

```

* Establish communication off

S2F15s1f13Off:'S2F15' W
 <L [1]
 <L [2]
 <U2 7> *Set Establish Communication OFF
 <BOOLEAN F> *
 >
 >.
```

```

* Disable All Events

S2F15DisableAllEvents:'S2F15' W
 <L [4]
 <L [2]
 <U2 5> *Disable Static event reports
 <U2 0> *1 to 16
 >
 <L [2]
 <U2 6> *Disable Static event report
 <U2 0> *17 to 30
 >
 <L [2]
 <U2 11> *Disable Static event reports
 <U2 0> *33 to 48
 >
 <L [2]
 <U2 12> *Disable Static event report
 <U2 0> *49 to 64
 >
 >.
```

```

* Enable All Events

S2F15EnableAllEvents:'S2F15' W
 <L [4]
 <L [2]
 <U2 5> *Enable Static event reports
 <U2 65535> *1 to 16
 >
 <L [2]
 <U2 6> *Enable Static event report
```

```

 <U2 65535> *17 to 30
 >
 <L [2]
 <U2 11> *Enable Static event reports
 <U2 65535> *33 to 48
 >
 <L [2]
 <U2 12> *Enable Static event report
 <U2 65535> *49 to 64
 >
 >.

```

```

```

```
* DATE/TIME Request
```

```

```

```
S2F17:'S2F17' W.
```

```

```

```
* Set Time and Date
```

```

```

```
*'S2F18'
```

```
* <A '951121123456'>. *Time Or <A '2000113023590000' > *16 bit
```

```
* SECS-SIM-Pro now handles this and returns
```

```
* dynamically the current date.
```

```
*
```

```

```

```
* Remote Command Abort Send
```

```

```

```
S2F21Abort:'S2F21' W
```

```
 <L[1]
```

```
 <U1 1> *RCMD 1=abort 2=continue 4=pause 6=stop
```

```
 >.
```

```

```

```
* Remote Command Continue Send
```

```

```

```
S2F21Continue:'S2F21' W
```

```
 <L[1]
```

```
 <U1 2> *RCMD 1=abort 2=continue 4=pause 6=stop
```

```
 >.
```

```

```

```
* Remote Command Pause Send
```

```

```

```
S2F21Pause:'S2F21' W
```

## Appendix M—SML File

---

```
<L [1]
<U2 4> *RCMD 1=abort 2=continue 4=pause 6=stop
>.

* Remote Command STOP Send

S2F21Stop:'S2F21' W
 <L [1]
 <U2 6> *RCMD 1=abort 2=continue 4=pause 6=stop
 >.

* Trace Initialize Send (TIS)

Trace1:'S2F23' W
 <L [5]
 <U2 1> *TRID Trace Identification Number Trace ID = 1
 <A '000001'> *Sample Period hmmmss = 1 second
 <U2 10> *Number of Samples at the above period 10 samples
 <U2 1> *Report Group Size = 1
 <L
 <U2 11> *RF Fwd Power Actual
 <U2 12> *RF Elapse Time Act.
 <U2 13> *Proc Press Actual
 <U2 14> *Gas 1 Flow Actual
 <U2 15> *Gas 2 Flow Actual
 <U2 16> *Gas 3 Flow Actual
 <U2 17> *Temperature Actual
 <U2 19> *Load Lock Press.
 <U2 20> *Shuttle Press.
 <U2 30> *RF Rev Power Actual
 >
>.

* Trace ON

S2F23Trace7:'S2F23' W
 <L [5]
 <U2 7> *Trace ID 7
 <A '000001'> *Trace time 1 min.
 <U2 15> *Total Wafer 10
 <U2 1> *REPGSZ=1
 <L [6]
 <U2 0> *Date & Time
```

```

 <U2 200> *Spool Count Actual
 <U2 201> *Spool Count Total
 <U2 202> *Spool Start Time
 <U2 203> *Spool Full Time
 <U2 204> *Spool State
 >
>.
```

S2F23TraceBackEndPoint:'S2F23' W

```

 <L [5]
 <U2 11> *Trace ID 11
 <A '000001'> *Trace time 1 sec.
 <U2 60> *Total traces 60
 <U2 1> *REPGSZ=1
 <L [4]
 <U2 40> * CO
 <U2 41> * O2
 <U2 42> * CO
 <U2 43> * O2
 >
>.
```

S2F23TraceRightEndPoint:'S2F23' W

```

 <L [5]
 <U2 12> *Trace ID 12
 <A '000001'> *Trace time 1 sec.
 <U2 60> *Total traces 60
 <U2 1> *REPGSZ=1
 <L [4]
 <U2 72> * CO
 <U2 73> * O2
 <U2 74> * CO
 <U2 75> * O2
 >
>.
```

S2F23TraceBackStopEndPoint:'S2F23' W

```

 <L [5]
 <U2 11> *Trace ID 11
 <A '000001'> *Trace time 1 sec.
 <U2 0> *Total traces 60
 <U2 1> *REPGSZ=1
 <L
 >
>.
```

## Appendix M—SML File

---

```
S2F23TraceRightStopEndPoint:'S2F23' W
 <L [5]
 <U2 12> *Trace ID 12
 <A '000001'> *Trace time 1 sec.
 <U2 0> *Total traces 60
 <U2 1> *REPGSZ=1
 <L
 >
>.
```

```

* Loopback Diag. Request

S2F25LoopbackDiag:'S2F25' W <B 0 1 2 4 8 16 32 64 80 FF>.
```

```

* Initial Process A Request

S2F27Test1:'S2F27' W
 <L [3]
 <U1 2>
 <A 'TEST 1'> * PPID
 <L [2]
 <A 'CA0001-00'> * MID
 <A 'CA0002-00'> * MID
 >
>.
```

```

* Initial Process A Request

S2F27Test2A:'S2F27' W
 <L [3]
 <U1 2>
 <A 'TEST 2'> * PPID
 <L [2]
 <A 'CA0001-00'> * MID
 <A 'CA0002-00'> * MID
 >
>.
```

```

* Initial Process B Request

S2F27Test2B:'S2F27' W
 <L [3]
```

```

<U1 2>
<A 'TEST 2'> * PPID
<L [2]
 <A 'samsungmattsnl1'> * MID
 <A 'samsungmattsnl2'> * MID
>
>.

```

```

```

```
* Equip.Constant Namelist
```

```

```

```
S2F29All:'S2F29' W
```

```

<L [13]
 <U2 0> *Establish Communication timeout
 <U2 1> *Set Event Report
 <U2 2> *t1 stuck sender timeout
 <U2 3> *t2 stuck receiver timeout
 <U2 4> *t3 send incomplete timeout
 <U2 5> *Enable/disable static event repot
 <U2 6> *Enable/disable static event repot
 <U2 7> *Set Establish Communication message
 <U2 8> *Set spool overwrite flag
 <U2 9> *Set Max spool transmit
 <U2 10> *Set GEM flag enable
 <U2 11> *Enable/disable event 33 to 48
 <U2 12> *Enable/disable event 49 to 64
>.

```

```

```

```
* Date & Time set Request
```

```

```

```
S2F31:'S2F31' W
```

```
 <A '95022220093000'>.
```

```

```

```
* Define Report
```

```

```

```
S2F33DefineReport:'S2F33' W
```

```

<L [2]
 <U2 1> *Data ID
<L
 <L [2]
 <U2 1> *Load Request Report 1
 <L [2]
 <U2 21> *Left outer MID

```



## Appendix M—SML File

---

```

 <U2 22> *Right outer MID
 >
>
<L [2]
<U2 2> *Process Start - Report 2
<L [3]
 <U2 21> *Left outer MID
 <U2 22> *Right outer MID
 <U2 1> *PPID
 >
>
<L [2]
<U2 3> *Process End - Report 3
<L [3]
 <U2 21> *Left outer MID
 <U2 22> *Right outer MID
 <U2 1> *PPID
 >
>
<L [2]
<U2 4> *Unload Request - Report 4
<L [3]
 <U2 21> *Left outer MID
 <U2 22> *Right outer MID
 <U2 1> *PPID
 >
>
<L [2]
<U2 5> *Unload Left Cassette - Report 5
<L [2]
 <U2 21> *Left Outer Cassette MID
 <U2 22> *Right Outer Cassette MID
 >
>
<L [2]
<U2 6> *Unload Right Cassette - Report 6
<L [2]
 <U2 21> *Left Outer Cassette MID
 <U2 22> *Right Outer Cassette MID
 >
>
<L [2]
<U2 7> *Unload complete - Report 7
<L [2]
 <U2 21> *Left Outer Cassette MID
 <U2 22> *Right Outer Cassette MID
```

```

 >
 >
<L [2]
 <U2 8> *Equipment Mode Change - Report 8
 <L [9]
 <U2 27> *
 <U2 28> *
 <U2 33> *
 <U2 34> *
 <U2 17> *
 <U2 6> *
 <U2 7> *
 <U2 104> *
 <U2 105> *
 >
>
<L [2]
 <U2 9>
 <L [1]
 <U2 44> * SIDE CHAMBER status
 * <U2 76> * BACK CHAMBER status
 >
>
<L [2]
 <U2 10> * End point failure - Report 10
 <L [1]
 <U2 81> * End point failure data
 >
>
<L [2]
 <U2 11> * Sampling process data (right) - Report 11
 <L [10]
 <U2 11> *RF Fwd Power Actual
 <U2 12> *RF Elapse Time Act.
 <U2 13> *Proc Press Actual
 <U2 14> *Gas 1 Flow Actual
 <U2 15> *Gas 2 Flow Actual
 <U2 16> *Gas 3 Flow Actual
 <U2 17> *Temperature Actual
 <U2 19> *Load Lock Press.
 <U2 20> *Shuttle Press.
 <U2 30> *RF Rev Power Actual
 >
>
<L [2]
 <U2 12> * Sampling process data (back) - Report 12

```

## Appendix M—SML File

---

```
<L [10]
 <U2 11> *RF Fwd Power Actual
 <U2 12> *RF Elapse Time Act.
 <U2 13> *Proc Press Actual
 <U2 14> *Gas 1 Flow Actual
 <U2 15> *Gas 2 Flow Actual
 <U2 16> *Gas 3 Flow Actual
 <U2 17> *Temperature Actual
 <U2 19> *Load Lock Press.
 <U2 20> *Shuttle Press.
 <U2 30> *RF Rev Power Actual
>
>
<L [2]
<U2 13> *Door open Report 13
<L [2]
 <U2 21> *Left outer MID
 <U2 22> *Right outer MID
>
>
<L [2]
<U2 14> *Door close Report 14
<L [2]
 <U2 21> *Left outer MID
 <U2 22> *Right outer MID
>
>
>
>.
```

\*\*\*\*\*

\* Clear Define Report

\*\*\*\*\*

S2F33ClearReport:'S2F33' W

<L [2]

<U2 0> \*Data ID

<L>

>.

\*\*\*\*\*

\* Link Event Report

\*\*\*\*\*

S2F35LinkReport:'S2F35' W

<L [2]

```

<U2 1> *DATA ID
<L
 <L [2]
 <U2 22> *Load Request
 <L [1]
 <U2 1> *Report ID 1
 >
 >
 <L [2]
 <U2 3> *Process Start
 <L [1]
 <U2 2> *Report ID 2
 >
 >
<L [2]
 <U2 6> *Process End
 <L [1]
 <U2 3> *Report ID 3
 >
>
 <L [2]
 <U2 20> *Unload Request
 <L [1]
 <U2 4> *Report ID 4
 >
 >
 <L [2]
 <U2 12> *Unload left Cassette
 <L [1]
 <U2 5> *Report ID 5
 >
 >
 <L [2]
 <U2 36> *Unload right Cassette
 <L [1]
 <U2 6> *Report ID 6
 >
 >
 <L [2]
 <U2 21> *Unload Complete
 <L [1]
 <U2 7> *Report ID 7
 >
 >
 <L [2]
 <U2 40> *Equipment Mode Changed

```

**Appendix M—SML File**

---

```
<L [1]
 <U2 8> *Report ID 8
 >
>
<L [2]
 <U2 43> *Chamber status changed
 <L [1]
 <U2 9> *Report ID 9
 >
 >
<L [2]
 <U2 90> *Endpoint Failure
 <L [1]
 <U2 10> *Report ID 10
 >
 >
<L [2]
 <U2 32> *Sampling process data (right)
 <L [1]
 <U2 11> *Report ID 11
 >
 >
<L [2]
 <U2 50> *Sampling process data (back)
 <L [1]
 <U2 12> *Report ID 12
 >
 >
<L [2]
 <U2 18> *door open
 <L [1]
 <U2 13> *Report ID 13
 >
 >
<L [2]
 <U2 19> *door close
 <L [1]
 <U2 14> *Report ID 14
 >
 >
>
>.
```

```

* En/Disable Event Report

```

```

S2F37EnableReportOld:'S2F37' W
 <L [2]
 <BOOLEAN T> *CEID
 <L
 <U2 3> *Process Started
 <U2 6> *Process Complete
 <U2 12> *left Cassette Removed
 <U2 13> *left Cassette Inserted
 <U2 14> *process step start
 <U2 15> *process step end
 <U2 16> *wafer process start
 <U2 17> *wafer process end
 <U2 18> *Door open
 <U2 19> *Door close
 <U2 20> *Unload Mat'l Complete
 <U2 21> *Unloading Mat'l Request
 <U2 22> *Load Mat'l Request
 <U2 23> *Loading Mat'l Complete
 <U2 33> *change to top wafer screen
 <U2 34> *change to bottom wafer screen
 <U2 35> *change to recipe number
 <U2 36> *right cassette removed
 <U2 37> *right cassette inserted
 <U2 38> *request to run menu
 <U2 40> *Equipment mode change
 <U2 41> *Request to rotate inner cassette out
 <U2 42> *idle timeout
 <U2 43> *Chamber status
 <U2 44> *Operator change to off-line
 <U2 90> *End point failure
 <U2 91> *AGV unload left complete
 <U2 92> *AGV unload right complete
 <U2 93> *AGV load left complete
 <U2 94> *AGV load right complete
 <U2 95> *AGV unload left request
 <U2 96> *AGV unload right request
 <U2 97> *AGV load left request
 <U2 98> *AGV load right request
 <U2 32> *Sampling process data (right)
 <U2 50> *Sampling process data (back)
 >
 >.

```

```

S2F37EnableReport:'S2F37' W
 <L [2]
 <BOOLEAN T> *CEID

```

<L  
<U2 3> \*Process Started  
<U2 6> \*Process Complete  
<U2 12> \*left Cassette Removed  
<U2 13> \*left Cassette Inserted  
<U2 14> \*process step start  
<U2 15> \*process step end  
<U2 16> \*wafer process start  
<U2 17> \*wafer process end  
<U2 18> \*Door open  
<U2 19> \*Door close  
<U2 20> \*Unload Mat'l Complete  
<U2 21> \*Unloading Mat'l Request  
<U2 22> \*Load Mat'l Request  
<U2 23> \*Loading Mat'l Complete  
<U2 33> \*change to top wafer screen  
<U2 34> \*change to bottom wafer screen  
<U2 35> \*change to recipe number  
<U2 36> \*right cassette removed  
<U2 37> \*right cassette inserted  
<U2 38> \*request to run menu  
<U2 40> \*Equipment mode change  
<U2 41> \*Request to rotate inner cassette out  
<U2 42> \*idle timeout  
<U2 43> \*Chamber Chamber status  
<U2 44> \*Operator change to off-line  
<U2 90> \*End Point failure  
<U2 91> \*AGV unload left complete  
<U2 92> \*AGV unload right complete  
<U2 93> \*AGV load left complete  
<U2 94> \*AGV load right complete  
<U2 95> \*AGV unload left request  
<U2 96> \*AGV unload right request  
<U2 97> \*AGV load left request  
<U2 98> \*AGV load right request  
<U2 32> \*Sampling process data (right)  
<U2 50> \*Sampling process data (back)  
<U2 100> \*Left Pod put on  
<U2 101> \*Right Pod put on  
<U2 102> \*Load Left Cassette request  
<U2 103> \*Load Right Cassette request  
<U2 104> \*Loader load left complete  
<U2 105> \*Loader load right complete  
<U2 106> \*Loader unload left request  
<U2 107> \*Loader unload right request  
<U2 108> \*Loader unload left complete

```

 <U2 109> *Loader unload right complete
 <U2 110> *Loader left ready to remove
 <U2 111> *Loader right ready to remove
 <U2 112> *Loader left removed
 <U2 113> *Loader right removed
 <U2 114> *Loader left comm error
 <U2 115> *Loader right comm error
 >
>.
```

```

* En/Disable Event Report

S2F37DisableReport:'S2F37' W
```

```

 <L [2]
 <BOOLEAN F> *CEED
 <L>
 >.
```

```

* Send Top/Bottom Wafer

```

```

S2F41Top25:'S2F41' W
 <L [2]
 <A 'TOP'>
 <L
 <L [2]
 <A 'WAFER'>
 <U2 25>
 >
 >
>.
```

```

S2F41Bottom1:'S2F41' W
 <L [2]
 <A 'BOTTOM'>
 <L
 <L [2]
 <A 'WAFER'>
 <U2 1>
 >
 >
>.
```



## Appendix M—SML File

---

S2F41Bottom25:'S2F41' W

```
<L [2]
 <A 'BOTTOM'>
 <L
 <L [2]
 <A 'WAFER'>
 <U2 25>
 >
 >
>.
```

S2F41Bottom15:'S2F41' W

```
<L [2]
 <A 'BOTTOM'>
 <L
 <L [2]
 <A 'WAFER'>
 <U2 15>
 >
 >
>.
```

```

* SEND LEFT/RIGHT WAFER COUNTS

```

S2F41Left25:'S2F41' W

```
<L [2]
 <A 'LEFT'>
 <L
 <L [2]
 <A 'WAFER'>
 <U2 25>
 >
 >
>.
```

/\* Count Sent can be 0 - 26 \*/

S2F41Right4:'S2F41' W

```
<L [2]
 <A 'RIGHT'>
 <L
 <L [2]
 <A 'WAFER'>
 <U2 4>
 >
 >
>.
```

```

>.

* SEND RECIPE BY NUMBER OR NAME

S2F41Recipe1:'S2F41' W
 <L [2]
 <A 'RECIPE'>
 <L
 <L [2]
 <A 'NUMBER'>
 <U2 1>
 >
 >
 >.

S2F41Recipe2:'S2F41' W
 <L [2]
 <A 'RECIPE'>
 <L
 <L [2]
 <A 'NUMBER'>
 <U2 2>
 >
 >
 >.

S2F41RecipeStripAll:'S2F41' W
 <L [2]
 <A 'RECIPE'>
 <L
 <L [2]
 <A 'NAME'>
 <A 'STRIPALL'> /*Name must match existing recipe on tool*/
 >
 >
 >.

* SEND RUN COMMANDS

S2F41RunContinous:'S2F41' W
 <L [2]
 <A 'RUN CONTINUOUS'>
 <L
 >
 >.

```

## Appendix M—SML File

---

```
S2F41RunSingle:'S2F41' W
 <L [2]
 <A 'RUN SINGLE'>
 <L
 >
 >.
```

```
S2F41Abort:'S2F41' W
 <L [2]
 <A 'ABORT'>
 <L
 >
 >.
```

```
S2F41Continue:'S2F41' W
 <L [2]
 <A 'CONTINUE'>
 <L
 >
 >.
```

```
S2F41Hold:'S2F41' W
 <L [2]
 <A 'HOLD'>
 <L
 >
 >.
```

```
S2F41NoCass:'S2F41' W
 <L [2]
 <A 'NO CASSETTES'>
 <L
 >
 >.
```

```

* CONTROL LIGHT TOWER LIGHTS

```

```
S2F41GreenOn:'S2F41' W
 <L [2]
 <A 'SIGNAL_TOWER'>
 <L
 <L [2]
 <A 'GREEN ' >
 <A '1'>
 >
 >
```

```
>
>.

S2F41GreenFlash:'S2F41' W
 <L [2]
 <A 'SIGNAL_TOWER'>
 <L
 <L [2]
 <A 'GREEN ' >
 <A '2'>
 >
 >
 >.

S2F41GreenOff:'S2F41' W
 <L [2]
 <A 'SIGNAL_TOWER'>
 <L
 <L [2]
 <A 'GREEN'>
 <A '0'>
 >
 >
 >.

S2F41RedOn:'S2F41' W
 <L [2]
 <A 'SIGNAL_TOWER'>
 <L
 <L [2]
 <A 'RED ' >
 <A '1'>
 >
 >
 >.

S2F41RedOff:'S2F41' W
 <L [2]
 <A 'SIGNAL_TOWER'>
 <L
 <L [2]
 <A 'RED'>
 <A '0'>
 >
 >
 >.
```

## Appendix M—SML File

---

S2F41RedFlash:'S2F41' W

```
<L [2]
 <A 'SIGNAL_TOWER'>
 <L
 <L [2]
 <A 'RED'>
 <A '2'>
 >
 >
>.
```

S2F41YellowOn:'S2F41' W

```
<L [2]
 <A 'SIGNAL_TOWER'>
 <L
 <L [2]
 <A 'YELLOW '>
 <A '1'>
 >
 >
>.
```

S2F41YellowOff:'S2F41' W

```
<L [2]
 <A 'SIGNAL_TOWER'>
 <L
 <L [2]
 <A 'YELLOW '>
 <A '0'>
 >
 >
>.
```

S2F41YellowFlash:'S2F41' W

```
<L [2]
 <A 'SIGNAL_TOWER'>
 <L
 <L [2]
 <A 'YELLOW '>
 <B 2>
 >
 >
>.
```

S2F41WhiteOn:'S2F41' W

```
<L [2]
 <A 'SIGNAL_TOWER'>
 <L
 <L [2]
 <A 'WHITE'>
 <A '1'>
 >
 >
>.
```

S2F41WhiteOff:'S2F41' W

```
<L [2]
 <A 'SIGNAL_TOWER'>
 <L
 <L [2]
 <A 'WHITE'>
 <A '0'>
 >
 >
>.
```

S2F41WhiteFlash:'S2F41' W

```
<L [2]
 <A 'SIGNAL_TOWER'>
 <L
 <L [2]
 <A 'WHITE'>
 <B 2>
 >
 >
>.
```

S2F41BlueOn:'S2F41' W

```
<L [2]
 <A 'SIGNAL_TOWER'>
 <L
 <L [2]
 <A 'BLUE'>
 <A '1'>
 >
 >
>.
```

S2F41BlueOff:'S2F41' W

```
<L [2]
 <A 'SIGNAL_TOWER'>
```

## Appendix M—SML File

---

```
<L
<L [2]
 <A 'BLUE'>
 <A '0'>
>
>
>.
```

S2F41BlueFlash:'S2F41' W

```
<L [2]
 <A 'SIGNAL_TOWER'>
 <L
 <L [2]
 <A 'BLUE'>
 <B 2>
 >
 >
>.
```

\*\*\*\*\*

\* OPEN/CLOSE CASSETTE DOOR

\*\*\*\*\*

S2F41OpenDoor:'S2F41' W

```
<L [2]
 <A 'OPEN DOOR'>
 <L
 >
>.
```

S2F41CloseDoor:'S2F41' W

```
<L [2]
 <A 'CLOSE DOOR'>
 <L
 >
>.
```

\*\*\*\*\*

\* SET EQUIPMENT MODES

\*\*\*\*\*

S2F41Manual:'S2F41' W

```
<L [2]
 <A 'MANUAL'>
 <L
```

```

>
>.

S2F41SemiAuto:'S2F41' W
 <L [2]
 <A 'SEMI-AUTO'>
 <L
 >
>.

S2F41FullAuto:'S2F41' W
 <L [2]
 <A 'FULL-AUTO'>
 <L
 >
>.

* SKIP EMPTY SLOTS YES/NO

S2F41SkipEmpty:'S2F41' W
 <L [2]
 <A 'SKIP EMPTY'>
 <L
 >
>.

S2F41NoEmptySlot:'S2F41' W
 <L [2]
 <A 'NO EMPTY SLOT'>
 <L
 >
>.

S2F41OPERATOR:'S2F41' W
 <L [2]
 <A 'OPERATOR'>
 <L [2]
 <A 'ID'>
 <A 'crb1'>
 >
 >
>.

S2F41BuzzerOn:'S2F41' W
 <L [2]
 <A 'BUZZER ON'>
 <L

```



## Appendix M—SML File

---

```
>
>.
```

```
S2F41BuzzerOff:'S2F41' W
```

```
<L [2]
 <A 'BUZZER OFF'>
 <L
 >
>.
```

```
S2F41LeakTest:'S2F41' W
```

```
<L [2]
 <A 'LEAK TEST'>
 <L
 >
>.
```

```
S2F41EngineerMode:'S2F41' W
```

```
<L [2]
 <A 'ENGINEER-MODE'>
 <L
 >
>.
```

```
S2F41SL1:'S2F41' W
```

```
<L [2]
 <A 'SELECTION'>
 <L
 <L [2]
 <A 'KEY'>
 <U2 1>
 >
 >
>.
```

```
S2F41SL2:'S2F41' W
```

```
<L [2]
 <A 'SELECTION'>
 <L
 <L [2]
 <A 'KEY'>
 <U2 2>
 >
 >
>.
```

```
S2F41SL3:'S2F41' W
 <L [2]
 <A 'SELECTION'>
 <L
 <L [2]
 <A 'KEY'>
 <U2 3>
 >
 >
 >.
```

```
S2F41SL4:'S2F41' W
 <L [2]
 <A 'SELECTION'>
 <L
 <L [2]
 <A 'KEY'>
 <U2 4>
 >
 >
 >.
```

```
S2F41SL5:'S2F41' W
 <L [2]
 <A 'SELECTION'>
 <L
 <L [2]
 <A 'KEY'>
 <U2 5>
 >
 >
 >.
```

```
S2F41SL6:'S2F41' W
 <L [2]
 <A 'SELECTION'>
 <L
 <L [2]
 <A 'KEY'>
 <U2 6>
 >
 >
 >.
```

```

* SMIF LOADER COMMANDS

```

## Appendix M—SML File

---

S2F41UnloadCassesL:'S2F41' W

<L [2]

<A 'UNLOAD CASSETTES'>

<L

<A 'PORT'>

<A '1'>

\* 1= LEFT, 2=RIGHT, 3=BOTH

>

>.

S2F41UnloadCassesR:'S2F41' W

<L [2]

<A 'UNLOAD CASSETTES'>

<L

<A 'PORT'>

<B 2>

\* 1= LEFT, 2=RIGHT, 3=BOTH

>

>.

S2F41UnloadCassesB:'S2F41' W

<L [2]

<A 'UNLOAD CASSETTES'>

<L

<A 'PORT'>

<B 3>

\* 1= LEFT, 2=RIGHT, 3=BOTH

>

>.

S2F41LockLeftPod:'S2F41' W

<L

<A 'LOCK POD'>

<L

<L

<A 'PORT'>

<B 1>

\* 1= LEFT, 2=RIGHT, 3=BOTH

>

>

>.

S2F41LockRightPod:'S2F41' W

<L

<A 'LOCK POD'>

<L

<L

<A 'PORT'>

<B 2>

\* 1= LEFT, 2=RIGHT, 3=BOTH

>

```
>
>.

S2F41LockBothPod:'S2F41' W
<L
 <A 'LOCK POD'>
 <L
 <L
 <A 'PORT'>
 <B 3>
 >
 >
>.
* 1= LEFT, 2=RIGHT, 3=BOTH

S2F41UnlockLeftPod:'S2F41' W
<L
 <A 'UNLOCK POD'>
 <L
 <L
 <A 'PORT'>
 <B 1>
 >
 >
>.
* 1= LEFT, 2=RIGHT, 3=BOTH

S2F41UnlockRightPod:'S2F41' W
<L
 <A 'UNLOCK POD'>
 <L
 <L
 <A 'PORT'>
 <B 2>
 >
 >
>.
* 1= LEFT, 2=RIGHT, 3=BOTH

S2F41UnlockBothPod:'S2F41' W
<L
 <A 'UNLOCK POD'>
 <L
 <L
 <A 'PORT'>
 <B 3>
 >
 >
>.
* 1= LEFT, 2=RIGHT, 3=BOTH
```

## Appendix M—SML File

---

S2F41LoadCassLeft:'S2F41' W

<L

<A 'LOAD CASSETTE'>

<L

<L

<A 'PORT'>

<B 1>

\* 1= LEFT, 2=RIGHT, 3=BOTH

>

>

>.

S2F41LoadCassRight:'S2F41' W

<L

<A 'LOAD CASSETTE'>

<L

<L

<A 'PORT'>

<B 2>

\* 1= LEFT, 2=RIGHT, 3=BOTH

>

>

>.

S2F41LoadCassBoth:'S2F41' W

<L

<A 'LOAD CASSETTE'>

<L

<L

<A 'PORT'>

<B 3>

\* 1= LEFT, 2=RIGHT, 3=BOTH

>

>

>.

S2F41UnloadCassLeft:'S2F41' W

<L

<A 'UNLOAD CASSETTE'>

<L

<L

<A 'PORT'>

<B 1>

\* 1= LEFT, 2=RIGHT, 3=BOTH

>

>

>.

S2F41UnloadCassRight:'S2F41' W

```

<L
 <A 'UNLOAD CASSETTE' >
 <L
 <L
 <A 'PORT' >
 <B 2> * 1= LEFT, 2=RIGHT, 3=BOTH
 >
 >
>.

S2F41UnloadCassBoth:'S2F41' W
<L
 <A 'UNLOAD CASSETTE' >
 <L
 <L
 <A 'PORT' >
 <B 3> * 1= LEFT, 2=RIGHT, 3=BOTH
 >
 >
>.

S2F41HexOptionSet:'S2F41' W * Allows host set Hex Option
<L
 <A 'HEX' >
 <L
 <L
 <A 'OPTION' >
 <U2 '2304' > /* Decimal Number 1 - 65535 */
 >
 >
>.

S2F41ActiveSide:'S2F41' W * Allows host selection of Active Chamber
<L
 <A 'ACTIVE' >
 <L
 <L
 <A 'CHAMBER' >
 <U2 1>
 >
 >
>.

S2F41ActiveBack:'S2F41' W

```

## Appendix M—SML File

---

```
<L
 <A 'ACTIVE'>
 <L
 <L
 <A 'CHAMBER'>
 <U2 2>
 >
 >
>.
```

/\* First binary is wafer 1 and last is Max Wafer 25 or 26\*/

```
S2F41WaferMapLeft:'S2F41' W * Allows host to send wafer map
<L
 <A 'SLOT MAP'>
 <L
 <L
 <A 'PORT 1'>
 <B '01 01 01 01 01 00 00 00 01 01 01 01 01 etc to Max Waf # >
 >
 >
>.
```

```
S2F41WaferMapRight:'S2F41' W
<L
 <A 'SLOT MAP'>
 <L
 <L
 <A 'PORT 2'>
 <B '01 01 01 01 01 00 00 00 01 01 01 01 01 etc to Max Waf # >
 >
 >
>.
```

/\* Send S2F41 Active Chamber First to select which chamber to reset Rf hours.\*/

```
S2F41RESETRFHOURS:'S2F41' W * Allows host to reset CN page Rf Hours
<L
 <A 'RESET'>
 <L
 <L
```

```

 <A 'RF HOURS'>
 <I2 '0' > * 0 - 500000
 >
>
>.
```

```

S2F41RESETWAFERSPROCESSED:'S2F41' W
<L
 <A 'RESET'>
 <L
 <L
 <A 'WAFS PROC'>
 <I2 '0' > *0 - 99999999
 >
 >
>.
```

```

S2F47:'S2F47' W
<L
>.
```

```

* Spooling Streams and Functions

```

```

S2F65SpoolOFF:'S2F65' W
<L
>.
```

```

S2F65SpoolON:'S2F65' W
<L [4]
 <L [2]
 <U1 3> *STRID Stream # = 3
 <L
 > * Zero list enable all Functions F11
 >
 <L [2]
 <U1 4> *STRID Stream # = 4
 <L
 > * Zero list enable all Functions F1,F17
 >
 <L [2]
 <U1 6> *STRID Stream # = 6
 <L
 > * Zero list enable all Functions F1,F3,F11,F13
 >
```



## Appendix M—SML File

---

```
<L [2]
 <U1 7> *STRID Stream # = 7
 <L
 > * Zero list enable all Functions F7
>
>.
```

S2F65SpoolONBad:'S2F65' W

```
<L [2]
 <L [2]
 <U1 2> *STRID Stream # = 1
 <L
 > * Zero list enables all Functions
 > * There is no Stream #1 Spooling
 <L [2]
 <U1 3> *STRID Stream # = 3
 <L [2]
 <U1 1> *There is no Stream #3 Spooling
 <U1 2> *for F1, F2
 >
 >
>.
```

\*\*\*\*\*  
\* Variable Limits Attributes  
\*\*\*\*\*

S2F85:'S2F85' W

```
<L
>.
```

S2F87DefineVarLimAttU:'S2F87' W

```
<L [2]
 <U2 1> * DATAID = 1
 <L
 > * Zero length make undefined
>.
```

S2F87DefineVarLimAttDBad:'S2F87' W

```
<L [2]
 <U2 1> * DATAID = 1, Only setting 2
VID's
 <L [2]
 <L [2]
 <U2 11>/* VID #11 RF Power 1st chamber, 2 VID Limits
Set
 <L [2]
```

```

 <L [2]
 <B 0> * Limit ID #0
 <L [2]
 <I2 100> * RF Power upper limit
 <I2 50> * RF Power lower limit
 >
 >
 <L [2]
 <B 1> * Limit ID #1
 <L [2]
 <I2 200> * RF Power upper limit
 <I2 50> * RF Power lower limit
 >
 >
 >
 <L [2]
 <U2 13> /* VID #13 Process Pressure, 1 VID Limits Set
 <L [1]
 <L [2]
 <B 0> * Limit ID #0
 <L [2]
 <F4 10.00>/*Process Press upper
limit
 <F4 0.50>/*Process Press lower
limit
 >
 >
 >
 >
 >
 >
 >.

```

```

S2F87DefineVarLimAttDOK:'S2F87' W
 <L [2]
 <U2 1> * DATAID = 1, Only setting 2 VID's
 <L [2]
 <L [2]
 <U2 11> /*VID #11 RF Pwr 1st cham, 2 VID Limits Set-
tings
 <L [2]
 <L [2]
 <B 1> * Limit ID #1
 <L [2]
 <I2 100> * RF Power upper limit
 <I2 50> * RF Power lower limit

```

**Appendix M—SML File**

```

 >
 >
 <L [2]
 <B 2> * Limit ID #2
 <L [2]
 <I2 200> * RF Power upper limit
 <I2 50> * RF Power lower limit
 >
 >
 >
 <L [2]
 <U2 13> /* VID #13 Process Pressure, 1 VID Limits Set-
ting
 <L [1]
 <L [2]
 <B 1> * Limit ID #1
 <L [2]
 <F4 10.00> * Process Press upper
limit
 <F4 0.50> * Process Press lower
limit
 >
 >
 >
 >
 >
 >.

* Abort Transaction

S3F0:S3F0 .

* Material ID Request Ack

*'S3F12'
* <L [3]
* <B 1> *Port No.
* <B 0> *MIDRA
* <A 'TEST1'> *MID
* >.

* Material ID Send

```

```
S3F13Mid1:'S3F13' W
 <L [2]
 <B 1> *Port No.
 <A 'CA0001-00'> *MID
 >.
```

```
S3F13Mid2:'S3F13' W
 <L [2]
 <B 2> *Port No.
 <A 'CA0002-00'> *MID
 >.
```

```
S3F13MID3:'S3F13' W
 <L [2]
 <B 1> *Port No.
 <A 'CA0003-00'> *MID
 >.
```

```
S3F13MID4:'S3F13' W
 <L [2]
 <B 2> *Port No.
 <A 'CA0004-00'> *MID
 >.
```

```

* Cassette ID Send

```

```
S3F13Cid1:'S3F13' W
 <L [2]
 <B 3> *Port No.
 <A 'CID-0000001'> *CID
 >.
```

```
S3F13Cid2:'S3F13' W
 <L [2]
 <B 4> *Port No.
 <A 'CID-0000002'> *CID
 >.
```

```
S3F13Cid3:'S3F13' W
 <L [2]
 <B 3> *Port No.
 <A 'CID-0000003'> *CID
 >.
```

**Appendix M—SML File**

---

S3F13Cid4:'S3F13' W

```
<L [2]
 <B 4> *Port No.
 <A 'CID-0000004'> *CID
>.
```

```

* Abort Transaction

S4F0:S4F0 .
```

```

* Ready to Send Material (RSN)

S4F1RdySndMarl1:'S4F1' W
 <L [2]
 <B 1> * Port Number Left
 <A 'crb1'>
 >.
```

```
S4F1RdySndMarl2:'S4F1' W
 <L [2]
 <B 1> * Port Number Right
 <A 'crb2'>
 >.
```

```
'S4F66'
 <B 0>.
```

```

* Abort Transaction

S5F0:S5F0 .
```

```

* Alarm Report Send

'S5F2'
 <B 0>.
```

```

* Disable Alarm Send

S5F3DisableAlarm:'S5F3' W
 <L [2]
 <B 00> *ALED
```

```

 <U2 0> *ALID
 >.

* Enable Alarm Send

S5F3EnableAlarm:'S5F3' W
 <L [2]
 <B 80> *ALED
 <U2 0> *ALID
 >.

* List All Alarm Request

S5F5All:'S5F5' W
 <U2>.

* List Alarm Request 2

S5F5Alarm123:'S5F5' W
 <U2 1 2 3>.

* List Enable Alarm Request

S5F7:'S5F7' W.

* Alarm notification Send

'S5F74'
 <B 0>.

* Abort Transaction

S6F0:S6F0 .

* Trace Data Send

'S6F2'
 <B 0>.

```

**Appendix M—SML File**

---

```

* Discrete Variable Data Send

'S6F4'
 <B 0>.
```

```

* Multi-block Data Send Inquire

'S6F6'
 <B 0>.
```

```

* Formatted Variable Send

'S6F10'
 <B 0>.
```

```

* Event Report Send

'S6F12'
 <B 0>.
```

```

* Annotated Event Report Send

'S6F14'
 <B 0>.
```

```

* Event Report Request

S6F15Ceid6:'S6F15' W
 <U2 6>. *CEID
```

```

* Annotated Event Report Request

S6F17Ceid6:'S6F17' W
 <U2 6>. *CEID
```

```

* Individual Report request

```

```

S6F19Rpid2:'S6F19' W
 <U2 2>. *RPTID

* Annotated Individual Report request

S6F21Rpid3:'S6F21' W
 <U2 3>. *RPTID

* Request Spooled Data (RSD)

S6F65ReqSpooledData:'S6F65' W
 <U1 0>. *RSDC Request Spooled Data Code 0 = Send

S6F65PurgeSpooledData:'S6F65' W
 <U1 1>. *RSDC Request Spooled Data Code 1 = Purge

* Abort Transaction

S7F0:S7F0 .

* Process Program Load Inquire

S7F1Test1:'S7F1' W
 <L [2]
 <A 'TEST 1'> *PPID
 <U2 333> *LENGTH
 >.

S7F1Test2:'S7F1' W
 <L [2]
 <A 'TEST 2'> *PPID
 <U2 333> *LENGTH
 >.

S7F1Test3:'S7F1' W
 <L [2]
 <A 'TEST 3' ' > *PPID
 <U2 333> *LENGTH
 >.

'S7F2'

```



## Appendix M—SML File

---

```
<B 0>.

'S7F4'
 <B 0>.

* Process Program Send

S7F3Test1:'S7F3' W
 <L [2]
 <A 'TEST 1'> *PPID
 <A '14000' 0x1E '350' 0x1E '100' 0x1E '2000' 0x1E '0'
 0x1E '0' 0x1E '50' 0x1E '0' 0x1E '0' 0x1E '250' 0x1E
 '0' 0x1E '0' 0x1E '0' 0x1E '0' 0x1E '0' 0x1E '0' 0x1E
 '0' 0x1E '0' 0x1E '0' 0x1E '0' 0x1E '0' 0x1E '0' 0x1E
 '0' 0x1E '0' 0x1E '0' 0x1E '0' 0x1E '0' 0x1E '0' 0x1E
 '0' 0x1E '0' 0x1E '0' 0x1E '0' 0x1E '0' 0x1E '0' 0x1E
 '0' 0x1E '0' 0x1E '0' 0x1E '0' 0x1E '0' 0x1E '0' 0x1E
 '0' 0x1E '0' 0x1E '0' 0x1E '0' 0x1E '0' 0x1E '0' 0x1E
 '0' 0x1E '0' 0x1E '0' 0x1E '0' 0x1E '0' 0x1E '0' 0x1E
 '0' 0x1E '0' 0x1E '0' 0x1E '0' 0x1E '0' 0x1E '0' 0x1E
 '0' 0x1E '0' 0x1E '0' 0x1E '0' 0x1E '0' 0x1E '0' 0x1E
 '0' 0x1E '0' 0x1E '0' 0x1E '0' 0x1E '0' 0x1E '0' 0x1E
 '0' 0x1E '0' 0x1E '0' 0x1E '0' 0x1E '0' 0x1E '0' 0x1E
 '0' 0x1E '0' 0x1E '0' 0x1E '0' 0x1E '0' 0x1E '0' 0x1E
 '0' 0x1E '0' 0x1E '0' 0x1E '0' 0x1E '0' 0x1E '0' 0x1E
 >.

S7F3Test2:'S7F3' W
 <L [2]
 <A 'TEST 2'> *PPID
 <A '14000' 0x1E '350' 0x1E '200' 0x1E '2000' 0x1E '0'
 0x1E '0' 0x1E '50' 0x1E '0' 0x1E '0' 0x1E '250' 0x1E
 '0' 0x1E '0' 0x1E '0' 0x1E '0' 0x1E '0' 0x1E '0' 0x1E
 '0' 0x1E '0' 0x1E '0' 0x1E '0' 0x1E '0' 0x1E '0' 0x1E
 >.

```



## Appendix M—SML File

---

```
'0' 0x1E '0' 0x1E '0' 0x1E '0' 0x1E '0' 0x1E '0' 0x1E '0' 0x1E
'0' 0x1E '0' 0x1E '0' 0x1E '0' 0x1E '0' 0x1E '0' 0x1E '0' 0x1E
'0' 0x1E '0' 0x1E '0' 0x1E '0' 0x1E '0' 0x1E '0' 0x1E '0' 0x1E
'0' 0x1E '0' 0x1E '0' 0x1E '0' 0x1E '0' 0x1E '0' 0x1E '0' 0x1E
'0' 0x1E '0' 0x1E '0' 0x1E '0' 0x1E '0' 0x1E '0' 0x1E '0' 0x1E
'0' 0x1E '0' 0x1E '0' 0x1E '0' 0x1E '0' 0x1E '0' 0x1E '0' 0x1E
'0' 0x1E '0' 0x1E '0' 0x1E '0' 0x1E '0' 0x1E '0' 0x1E '0' 0x1E
'0' 0x1E '0' 0x1E>
```

>.

```

```

```
* Process Program Request
```

```

```

```
S7F5Test1:'S7F5' W
```

```
<A 'TEST 1'>. *PPID
```

```
S7F5Test2:'S7F5' W
```

```
<A 'TEST 2'>. *PPID
```

```
S7F5Test3:'S7F5' W
```

```
<A 'TEST 3' >. *PPID
```

```

```

```
* Process Program ID Request
```

```

```

```
'S7F8'
```

```
<L [2]
```

```
<A 'TEST 1'> *PPID
```

```
<A 'CA0001-00'> *MID
```

```
>.
```

```

```

```
* Delete Process Program Send
```

```

```

```
S7F17Test1:'S7F17' W
```

```
<L [1]
```

```
<A 'TEST 1'> *PPID
```

```
>.
```

```
S7F17Test2:'S7F17' W
```

```
<L [1]
```

```
<A 'TEST 2'> *PPID
```

```
>.
```

```
S7F17Test3:'S7F17' W
 <L [1]
 <A 'TEST 3'> *PPID
 >.
```

```
S7F17Test12:'S7F17' W
 <L [2]
 <A 'TEST 1'> *PPID
 <A 'TEST 2'> *PPID
 >.
```

```
S7F17Test13:'S7F17' W
 <L []
 <A 'TEST 1'> *PPID
 <A 'TEST 3'> *PPID
 >.
```

```
S7F17Test23:'S7F17' W
 <L [2]
 <A 'TEST 2'> *PPID
 <A 'TEST 3'> *PPID
 >.
```

```

* Current EPPD Request

S7F19:'S7F19' W.
```

```

* Formatted Process Program Send

S7F23Test1:'S7F23' W
```

```
 <L [4]
 <A 'TEST 1'>
 <A 'ASPEN'>
 <A '2.06C9'>
 <L [11]
 <L [2] *STEP ONE OF RECIPE (STEP 1 - 10 USE AS SHOWN)
 <U2 0> *STEP 11 FOR ENDPOINT PARAMETERS
 <L [15]
 <U2 0> *RF TIME 1/10 SECONDS
 <U2 80> *RF DELAY TIME 1/10 SECONDS
 <I2 0> *RF POWER WATTS
 <I4 3500> *PROCESS PRESSURE MTORR
```

## Appendix M—SML File

---

```
<U2 5000> *GAS 1 FLOW SETTING SCCM
<U2 100> *GAS 2 FLOW SETTING SCCM
<U2 0> *GAS 3 FLOW SETTING SCCM
<I2 250> *TEMPERATURE SETTING DEGREES CELSIUS
<U2 0> *ENDPOINT ENABLE ONE STEP ONLY 0=NO 1=REG 2=PS
<U2 0> *ATTRIBUTE GN/PIN/EP1/RFT%/SII 0=NNNNN 63=YYYYY
<I2 1> *NEXT STEP 0=NO 1=YES
<I2 0> *PRECOND RECIPE 0 - 99
<I2 0> *PRECOND FREQ 0 - 10
<U2 0> *GAS 4 FLOW SETTING SCCM
<I4 0> *RESERVED
>
>
<L [2] *STEP 2
 <U2 0>
 <L [15]
 <U2 20>
 <U2 80>
 <I2 900>
 <I4 1100>
 <U2 800>
 <U2 100>
 <U2 0>
 <I2 250>
 <U2 0>
 <U2 0>
 <I2 1>
 <I4 0>
 <I4 0>
 <I4 0>
 <I4 0>
 >
>
<L [2]
 <U2 0>
 <L [15]
 <U2 0>
 <U2 0>
 <I2 0>
 <I4 0>
 <U2 0>
 <U2 0>
 <U2 0>
 <I2 0>
 <U2 0>
 <U2 0>
```

```
<I2 0>
<I4 0>
<I4 0>
<I4 0>
<I4 0>
>
>
<L [2]
 <U2 0>
 <L [15]
 <U2 0>
 <U2 0>
 <I2 0>
 <I4 0>
 <U2 0>
 <U2 0>
 <U2 0>
 <I2 0>
 <U2 0>
 <U2 0>
 <I2 0>
 <I4 0>
 <I4 0>
 <I4 0>
 <I4 0>
 >
>
<L [2]
 <U2 0>
 <L [15]
 <U2 0>
 <U2 0>
 <I2 0>
 <I4 0>
 <U2 0>
 <U2 0>
 <U2 0>
 <I2 0>
 <U2 0>
 <U2 0>
 <I2 0>
 <I4 0>
 <I4 0>
 <I4 0>
 <I4 0>
 >
>
```

## Appendix M—SML File

---

```
>
<L [2]
 <U2 0>
 <L [15]
 <U2 0>
 <U2 0>
 <I2 0>
 <I4 0>
 <U2 0>
 <U2 0>
 <U2 0>
 <I2 0>
 <U2 0>
 <U2 0>
 <I2 0>
 <I4 0>
 <I4 0>
 <I4 0>
 <I4 0>
 >
>
<L [2]
 <U2 0>
 <L [15]
 <U2 0>
 <U2 0>
 <I2 0>
 <I4 0>
 <U2 0>
 <U2 0>
 <U2 0>
 <I2 0>
 <U2 0>
 <U2 0>
 <I2 0>
 <I4 0>
 <I4 0>
 <I4 0>
 <I4 0>
 >
>
<L [2]
 <U2 0>
 <L [15]
 <U2 0>
 <U2 0>
```

```

 <I2 0>
 <I4 0>
 <U2 0>
 <U2 0>
 <U2 0>
 <I2 0>
 <U2 0>
 <U2 0>
 <I2 0>
 <I4 0>
 <I4 0>
 <I4 0>
 <I4 0>
 >
>
<L [2]
 <U2 0>
 <L [15]
 <U2 0>
 <U2 0>
 <I2 0>
 <I4 0>
 <U2 0>
 <U2 0>
 <U2 0>
 <I2 0>
 <U2 0>
 <U2 0>
 <I2 0>
 <I4 0>
 <I4 0>
 <I4 0>
 <I4 0>
 >
>
<L [2]
 <U2 0>
 <L [15]
 <U2 0>
 <U2 0>
 <I2 0>
 <I4 0>
 <U2 0>
 <U2 0>
 <U2 0>
 <I2 0>
 >

```



**Appendix M—SML File**

---

```

 <U2 0>
 <U2 0>
 <I2 0>
 <I4 0>
 <I4 0>
 <I4 0>
 <I4 0>
 >
>
<L [2] *STEP 11 FOR ENDPOINT PARAMETERS
 <U2 0>
 <L [15]
 <U2 2> *ENDPOINT TYPE 0=NONE 1=REGULAR 2=PEAK SEARCH
 <U2 0> *UPSLOPE THRESHOLD 1-200 COUNTS, 0=DISABLED
 <I2 0> *RESERVED
 <I4 100> *MINIMUM CHANGE 1 - 1000 COUNTS, 0 = DISABLED
 <U2 1> *SCALE/SENSITIVITY 1 - 8, 9 =DATA COLLECT, 0 = DIS-
ABLED
 <U2 1> *CHANNEL SELECT 0 = A, 1 = B, 2 = A&B
 <U2 10> *START DELAY TIME 0 TO 30 SECONDS
 <I2 50> *FINAL THRESHOLD 1 - 99%, 0 = DISABLED
 <U2 0> *PEAK DEBOUNCE 1 - 60 COUNTS 0 = DISABLED
 <U2 200> *MINIMUM TIME 0 - <Max Step Time IN DECI-SECONDS
 <I2 0> *DOWNSLOPE THRESHOLD 1 -200 COUNTS, 0 = DISABLED
 <I4 0> *FLAT PEAK DEVIATION 1 - 30 COUNTS, 0 = DISABLED
 <I4 0> *FLAT PEAK COUNTS 1 - 60, 0 = DISABLED
 <I4 0> *RESERVED
 <I4 0> *RESERVED
 >
>
>.

'S7F24' <B 0>..

* Invalid Formatted Process Program Send

S7F23Test1Invalid:'S7F23' W
 <L [4]
 <A 'TEST 1'>
 <A 'ASPEN'>
 <A '2.06C9'>
 <L [10]
 <L [2]
 <U2 0>
 <L [15]

```

```

 <U2 108>
 <U2 30>
 <I2 125> * 0 to 1200
 <I4 90010> * 50 to 9000 for ICP, other 500 to 90000
 <U2 500> * gas flow 1, MFC size 5000
 <U2 600> * gas flow 2
 <U2 700> * gas flow 3
 <I2 350>
 <U2 2>
 <U2 0>
 <I2 0>
 <I4 0>
 <I4 0>
 <I4 0>
 <I4 0>
 >
 >
<L [2]
 <U2 0>
 <L [15]
 <U2 108>
 <U2 30>
 <I2 250>
 <I4 3600>
 <U2 1900>
 <U2 2800>
 <U2 0>
 <I2 350>
 <U2 2>
 <U2 0>
 <I2 0>
 <I4 0>
 <I4 0>
 <I4 0>
 <I4 0>
 >
>
<L [2]
 <U2 0>
 <L [15]
 <U2 108>
 <U2 30>
 <I2 250>
 <I4 3600>
 <U2 1900>
 <U2 2800>

```

## Appendix M—SML File

---

```
<U2 0>
<I2 350>
<U2 2>
<U2 0>
<I2 0>
<I4 0>
<I4 0>
<I4 0>
<I4 0>
>
>
<L [2]
 <U2 0>
 <L [15]
 <U2 108>
 <U2 30>
 <I2 250>
 <I4 3600>
 <U2 1900>
 <U2 2800>
 <U2 0>
 <I2 350>
 <U2 2>
 <U2 0>
 <I2 0>
 <I4 0>
 <I4 0>
 <I4 0>
 <I4 0>
 >
>
<L [2]
 <U2 0>
 <L [15]
 <U2 108>
 <U2 30>
 <I2 250>
 <I4 3600>
 <U2 1900>
 <U2 2800>
 <U2 0>
 <I2 350>
 <U2 2>
 <U2 0>
 <I2 0>
 <I4 0>
```

```
<I4 0>
<I4 0>
<I4 0>
>
>
<L [2]
 <U2 0>
 <L [15]
 <U2 108>
 <U2 30>
 <I2 250>
 <I4 3600>
 <U2 1900>
 <U2 2800>
 <U2 0>
 <I2 350>
 <U2 2>
 <U2 0>
 <I2 0>
 <I4 0>
 <I4 0>
 <I4 0>
 <I4 0>
 >
>
<L [2]
 <U2 0>
 <L [15]
 <U2 108>
 <U2 30>
 <I2 250>
 <I4 3600>
 <U2 1900>
 <U2 2800>
 <U2 0>
 <I2 350>
 <U2 2>
 <U2 0>
 <I2 0>
 <I4 0>
 <I4 0>
 <I4 0>
 <I4 0>
 >
>
<L [2]
```

## Appendix M—SML File

---

```
<U2 0>
<L [15]
 <U2 108>
 <U2 30>
 <I2 250>
 <I4 3600>
 <U2 1900>
 <U2 2800>
 <U2 0>
 <I2 350>
 <U2 2>
 <U2 0>
 <I2 0>
 <I4 0>
 <I4 0>
 <I4 0>
 <I4 0>
 >
>
<L [2]
 <U2 0>
 <L [15]
 <U2 108>
 <U2 30>
 <I2 250>
 <I4 3600>
 <U2 1900>
 <U2 2800>
 <U2 0>
 <I2 350>
 <U2 2>
 <U2 0>
 <I2 0>
 <I4 0>
 <I4 0>
 <I4 0>
 <I4 0>
 >
>
<L [2]
 <U2 0>
 <L [15]
 <U2 108>
 <U2 30>
 <I2 250>
 <I4 3600>
```





```

 <A 'this is test14'>
 <A 'this is test15'>
 <A 'this is test16'>
 <A 'this is test17'>
 <A 'this is test18'>
 <A 'this is test19'>
 >
>.

```

S10F5STRIP1:'S10F5' W

<L [2]

<B 0>

<L [11]

<A ''>

<A ''>

<A ''>

<A ''>

<A ''>

<A ' |

<A ' |

<A ' |

<A ' |

<A ' |

<A ' |

>

>.

| Port Number | Lot ID   | PPID |
|-------------|----------|------|
| Port 1      | LOT00001 | SIN3 |
| Port 2      | LOT00002 | SIN3 |

S10F5STRIP2:'S10F5' W

<L [2]

<B 0>

<L [13]

<A ''>

<A ''>

<A ''>

<A ''>

<A ''>

<A ' |

<A ' |

<A ' |

<A ' |

<A ' |

<A ' |

<A ' |

<A ' |

>

| Port Number | Lot ID   | PPID |
|-------------|----------|------|
| Port 1      | LOT00001 | SIN3 |
| Port 2      | LOT00002 | SIN3 |
| Port 3      | LOT00003 | SIN3 |
| Port 4      | LOT00004 | SIN3 |



**Appendix M—SML File**

---

```

>.

S10F5STRIP3:'S10F5' W
 <L [2]
 <B 0>
 <L [11]
 <A ''>
 <A ''>
 <A ''>
 <A ''>
 <A ''>
 <A ''>
 <A '
 -----'>
 <A ' | Port Number Lot ID Next Step |'>
 <A ' |-----|'>
 <A ' | Port 1 LOT00001 Thickness |'>
 <A ' | Port 2 LOT00002 |'>
 <A ' |-----|'>
 >
 >.

```

```

* Auto response command

IF (S1F1 W) S1F2.
IF (S1F13 W) S1F14.
IF (S2F17 W) S2F18.
IF (S3F11 W) S3F12.
IF (S5F1 W) S5F2.
IF (S5F73 W) S5F74.
IF (S6F1 W) S6F2.
IF (S6F3 W) S6F4.
IF (S6F5 W) S6F6.
IF (S6F9 W) S6F10.
IF (S6F11 W) S6F12.
IF (S6F13 W) S6F14.
IF (S7F1 W) S7F2.
IF (S7F3 W) S7F4.
IF (S7F7 W) S7F8.
IF (S7F27 W) S7F28.
IF (S4F65 W) S4F66.

```