



Allen-Bradley

Technical Data

MicroLogix 1500 Programmable Controllers

Bulletin 1764



Table of Contents	MicroLogix 1500 System	3
	MicroLogix 1500 Components	5
	MicroLogix 1500 System Expansion	10
	Compact Expansion I/O	11
	Communications	15
	Programming Instructions	18
	Programming Software	18
	Network and Programming Cables	19
	Dimensions	20
	System Expansion Calculations	22
	For More Information	26

Tables and Figures	Table 1 - MicroLogix 1500 Controller General Specifications	5
	Figure 2 - Catalog Number Detail	5
	Table 3 - MicroLogix 1500 Controller Power and I/O Configuration	5
	Table 4 - Base Unit Power Supply Specifications	6
	Figure 5 - Choosing a Power Supply for the 1764-28BxB	6
	Table 6 - Base Unit Input Specifications	7
	Table 7 - Base Unit Output Specifications	7
	Table 8 - Relay Contact Rating	7
	Table 9 - Environmental Specifications	8
	Table 10 - Memory and Real-Time Clock Modules	9
	Table 11 - Compact Digital Input Modules Selection Chart	12
	Table 12 - Compact Digital Output Modules Selection Chart	12
	Table 13 - Compact Combination Input and Output Module Selection Chart	12
	Table 14 - Compact Analog I/O Modules Selection Chart	13
	Table 15 - Compact Temperature Input Modules Selection Chart	13
	Table 16 - Compact High-Speed Counter Module Selection Chart	13
	Table 17 - Compact DeviceNet Scanner Module Selection Chart	13
	Table 18 - Compact Power Supplies Specifications	14
	Table 19 - Compact Expansion Cables Selection Chart	14
	Table 20 - Compact End Caps Selection Chart	14
	Table 21 - MicroLogix 1500 Network Options	15
	Table 22 - DH-485 Network Specifications	16
	Table 23 - DeviceNet Specifications	16
	Table 24 - Ethernet Specifications	17
	Table 25 - Network Modules Specifications	17
	Table 26 - RSLogix 500 Selection Chart	18
	Table 27 - Controller and PC Port Identification	19
	Figure 28 - Network Interface Devices Communication Port Identification	19
	Table 29 - Network Cable Selection Chart	19
	Table 30 - Programming Cable Selection Chart	19
	Figure 31 - Compact I/O with MicroLogix 1500 Base Unit and Processor	20
	Figure 32 - Expansion Bank with Power Supply, Expansion Cable, and End Cap	20
	Figure 33 - Spacing for Single-Wide and One and One-Half-Wide Modules	21
	Figure 34 - Network Interface Devices Dimensions	21
	Table 35 - Selecting Hardware: Base Unit and Communications/Display Devices	22
	Table 36 - Selecting Hardware: Expansion I/O	23
	Table 37 - Base Unit Power Supply Loading - Verify the Current Limits	24
	Table 38 - Base Unit Power Supply Loading - Verify the Required Power	24
	Table 39 - Bank 1 Power Supply Loading - Verify the Current Limits	25
	Table 40 - Select End Cap and Expansion Cable	25
	Table 41 - Related Publications for MicroLogix 1500 Controllers	26
	Table 42 - MicroLogix 1000 and 1200 Technical Data Publications	26

MicroLogix 1500 System



The MicroLogix 1500 is a world-class programmable logic control platform with advanced features and performance. Many of these features allow this controller to be used in applications where much larger controllers were required in the past.

MicroLogix 1500 architecture features an innovative two-piece design with a small footprint. The processor and base units slide together to form the complete controller. The processor and base are independently replaceable, allowing you to maximize your embedded I/O options while minimizing inventory stocking costs.

Bulletin 1769 Compact I/O modules expand the controller's embedded I/O offerings and provide the additional flexibility to cover a wide range of applications. This high-performance modular and rackless I/O platform provides front accessibility for removal and insertion, lowering system cost and reducing maintenance time.

The MicroLogix 1500 controller utilizes Rockwell Software RSLogix 500 programming software and shares a common instruction set with the MicroLogix 1000, MicroLogix 1200 and SLC families of controllers.

New features are provided with an enhanced user interface that uses function files to consolidate programming parameters. This simplifies the user interface and increases controller performance.

A field-upgradable flash operating system ensures you will always be up-to-date with the latest features, without having to replace hardware. The controller can be easily updated with the latest firmware via a web site download.

Advantages

- Large memory to solve a variety of applications. Memory size:
 - 1764-LSP: 7K user program capacity
 - 1764-LRP:14K user program capacity
- Field-upgradable flash operating system
- High performance expansion I/O options (up to 16 modules depending on power budget and Base Unit)
- Advanced communications options including peer-to-peer and SCADA/RTU networks, DH-485, DeviceNet, and Ethernet
 - via the Communications Port on the Base Unit
 - via the additional RS-232 port on the 1764-LRP processor
- Communications toggle push button
- Data file download protection prevents critical user data from being altered via communications
- Battery (built-in and optional replacement)
- Mode switch for Run/Remote/Program
- Two built-in analog trim potentiometers
- Optional real-time clock
- Optional memory module
- Optional data access tool (DAT)
- 20 kHz high-speed counter, featuring 8 modes of operation
- Two high-speed outputs that can be configured as 20 kHz PTO (Pulse Train Output) or as PWM (Pulse Width Modulated) outputs
- Eight high-speed latching (pulse-catch) inputs
- 32-bit signed integer math
- Floating point data file
- Built-in PID capabilities
- ASCII read/write capability
- Recipe (RCP) instruction saves custom lists of recipe data
- Data logging (1764-LRP only) instruction stores data records with optional time stamp
- Four event interrupt inputs (EII)
- 1 ms high-resolution timers
- 1 ms selectable timed interrupt (STI)
- Finger-safe terminal blocks meet global safety standards
- Removable terminal blocks allow pre-wiring
- Regulatory agency certifications for world-wide market (CE, C-Tick, UL, c-UL, including Class I Division 2 Hazardous Location)

Controller Specifications

Table 1 MicroLogix 1500 Controller General Specifications

Specification	All 1764 Controllers
Memory Size and Type	if using 1764-LSP processor: 7K user memory (total user program plus data) if using 1764-LRP processor: 14K user memory (total user program plus data)
Data Elements	configurable, user-defined file structure, 4K max. data size
Throughput	1 ms (for a typical 1K word user program) ⁽¹⁾

(1) A typical user program contains bit, timer, counter, math and file instructions.

MicroLogix 1500 Components

Base Units

The Base Unit houses embedded inputs, outputs, power supply, and the channel 0 communications port. The base unit also provides the interface to expansion I/O when required by an application.

Figure 2 Catalog Number Detail

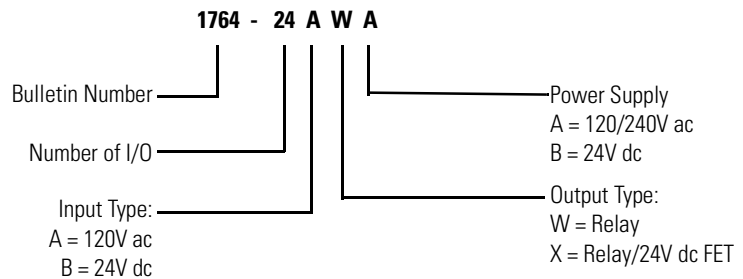

Table 3 MicroLogix 1500 Controller Power and I/O Configuration

Line Power	Inputs	Outputs	High Speed I/O	Catalog Number
120/240V ac	(12) 120V ac	(12) Relay, 2 isolated relays per unit	n/a	1764-24AWA
120/240V ac	(8) Standard 24V dc (4) Fast 24V dc	(12) Relay, 2 isolated relays per unit	(4) 20 kHz input	1764-24BWA
24V dc	(8) Standard 24V dc (8) Fast 24V dc	(6) Relay, 2 isolated relays per unit (4) Standard 24V dc FET (2) Fast 24V dc FET	(8) 20 kHz input (2) 20 kHz output	1764-28BXB

Table 4 Base Unit Power Supply Specifications

Specification		1764-24AWA	1764-24BWA	1764-28BXB
Power Supply Voltage		85 to 265V ac at 47 to 63 Hz	85 to 265V ac at 47 to 63 Hz	20.4 to 30V dc
Power Consumption		70 VA	88 VA	30W
Power Supply Max Inrush Current (max.)		120V ac: 25A for 8 ms 240V ac: 40A for 4 ms	120V ac: 25A for 8 ms 240V ac: 40A for 4 ms	24V dc: 4A for 150 ms
Maximum Load Current ⁽¹⁾	5V dc	2250 mA	2250 mA ⁽²⁾	2250 mA
	24V dc	400 mA	400 mA ⁽²⁾	400 mA
Maximum Load Power		16W	22W	16W
24V dc Sensor Power		n/a	400 mA ⁽²⁾ , 400 μ F capacitance max.	n/a

(1) See System Expansion Calculations on page 22 for an example system validation worksheet to calculate expansion I/O power usage.

(2) Do not allow the total load power consumed by the 5V dc, 24V dc, and sensor power outputs to exceed 22W.

Figure 5 Choosing a Power Supply for the 1764-28BXB

This figure contains information for selecting a power supply for applications using a 1764-28BXB base unit. Use the worksheets on page 22 to calculate the total power (Watts) consumed by the system. With that information, use the graphs below to choose a power supply. You can use either current or power, depending on how the power supply is rated.

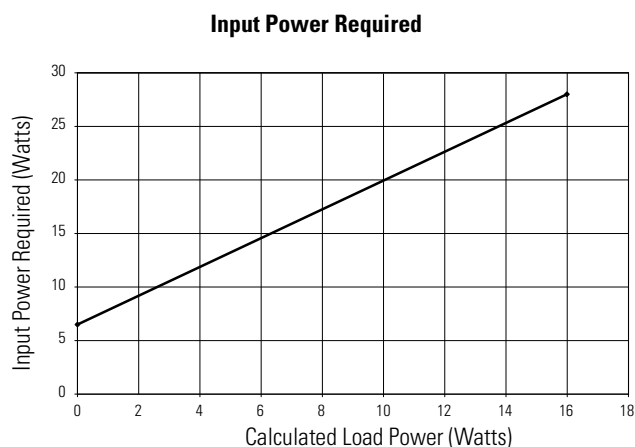
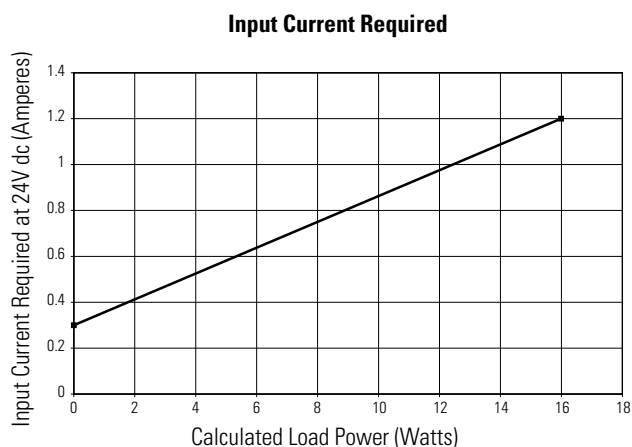

Table 6 Base Unit Input Specifications

Specification	1764-24AWA	1764-24BWA and 1764-28BXB	
		Inputs 0 thru 7	Inputs 8 and Higher
On-State Voltage Range	79 to 132V ac at 47 Hz to 63 Hz	14 to 30.0 V dc at 30°C (86°F) 14 to 26.4 V dc at 55°C (131°F)	10 to 30.0 V dc at 30°C (86°F) 10 to 26.4 V dc at 55°C (131°F)
Off-State Voltage Range	0 to 20V ac	0 to 5V dc	0 to 5V dc
Operating Frequency	n/a	1 kHz to 20 KHz	1 Hz to 500 Hz
Signal Delay	ON Delay = 20 ms OFF Delay = 20 ms	standard inputs: selectable from 0.5 to 16 ms high-speed inputs: selectable from 0.025 to 16 ms	
On-State Current Minimum Nominal Maximum	5.0 mA at 79V ac 12.0 mA at 120V ac 16.0 mA at 132V ac	2.5 mA at 14V dc 7.3 mA at 24V dc 12.0 mA at 30V dc	2.0 mA at 10V dc 8.9 mA at 24V dc 12.0 mA at 30V dc
Off-State Leakage Current	2.5 mA minimum	1.5 mA minimum	1.5 mA minimum
Nominal Impedance	12K Ω at 50 hZ 10K Ω at 60 Hz	3.3K Ω	2.7K Ω
Inrush Current (max)	250 mA at 120V ac	n/a	n/a

Table 7 Base Unit Output Specifications

Specification	1764-24AWA, -24BWA, -28BXB	1764-28BXB	
	Relay	FET Standard Operation	FET High-Speed Operation (Outputs 2 and 3 only)
Operating Voltage Range	5 to 125V dc 5 to 264V ac	20.4 to 26.4V dc	
Continuous Current per Point (max.)	See Table 8, Relay Contact Rating.	1A at 55°C (+131°F) 1.5A at 30°C (+86°F)	100 mA
Continuous Current per Common (max.)	8.0A	6.0A	
Continuous Current per Controller (max.)	24A at 150V 20A at 240V	18A at 150V 18A at 240V	
On-State Current (min.)	5.0 mA at 79V ac	2.5 mA at 14V dc	2.0 mA at 10V dc
Off-State Leakage Current (max.)	0 mA	1 mA	
Signal Delay (max.) - resistive load	ON Delay = 10 ms OFF Delay = 10 ms	ON Delay = 0.1 ms OFF Delay = 1.0 ms	ON Delay = 6 μ s OFF Delay = 18 μ s
Surge Current per Point (peak)	n/a	4A for 10 ms ⁽¹⁾	





(1) Repeatability is once every 2 seconds at +55°C (+131°F), once every 1 second at +30°C (+86°F).

Table 8 Relay Contact Rating

Maximum Voltage	Amperes		Amperes Continuous	Voltamperes	
	Make	Break		Make	Break
240V ac	7.5A	0.75A	2.5A	1800 VA	180 VA
120V ac	15A	1.5A			
125V dc	0.22A ⁽¹⁾		1.0A	28 VA	
24V dc	1.2A ⁽¹⁾		2.0A		

(1) For dc voltage applications, the make/break ampere rating for relay contacts can be determined by dividing 28 VA by the applied dc voltage. For example, 28 VA/48V dc = 0.58A. For dc voltage applications less than 48V, the make/break ratings for relay contacts cannot exceed 2A. For dc voltage applications greater than 48V, the make/break ratings for relay contact cannot exceed 1A.

Table 9 Environmental Specifications

Description	1764 Controllers
Operating Temperature	+0°C to +55°C (+32°F to +131°F)
Storage Temperature	-40°C to +85°C (-40°F to +185°F) ⁽¹⁾
Operating Humidity	5% to 95% relative humidity (non-condensing)
Vibration	Operating: 10 to 500 Hz, 5G, 0.030 in. max. peak-to-peak Relay Operation: 2G
Shock (without Data Access Tool installed)	Operating: 30G panel mounted (15G DIN Rail mounted) Relay operation: 7.5G panel mounted (5G DIN Rail mounted) Non-Operating: 40G panel mounted (30G DIN Rail mounted)
Shock (with Data Access Tool installed)	Operating: 20G panel mounted (15G DIN Rail mounted) Relay operation: 7.5G panel mounted (5G DIN Rail mounted) Non-Operating: 30G panel mounted (20G DIN Rail mounted)
Agency Certification	 UL Listed Industrial Control Equipment  UL Listed Industrial Control Equipment for use in Canada  UL Listed Industrial Control Equipment for use in Class I, Division 2 Hazardous Locations Groups A, B, C, D  Marked for all applicable directives  Marked for all applicable acts <small>N223</small>
Electrical/EMC	<p>The controller has passed testing at the following levels:</p> <ul style="list-style-type: none"> • EN 61000-4-2: 4 kV contact, 8 kV air, 4 kV indirect • EN 61000-4-3: 10V/m, 80 to 1000 MHz, 80% amplitude modulation, +900 MHz keyed carrier • EN 61000-4-4: 2 kV, 5 kHz; communications cable: 1 kV, 5 kHz • EN 61000-4-5: communications cable 1 kV galvanic gun I/O: 2 kV CM (common mode), 1 kV DM (differential mode) AC Power Supply: 4 kV CM (common mode), 2 kV DM (differential mode) DC Power Supply: 500V CM (common mode), 500V DM (differential mode) • EN 61000-4-6: 10V, communications cable 3V

(1) Recommended storage temperature for maximum battery life (5 years typical with normal operating/storage conditions) of the 1764-RTC, 1764-MM1RTC, and 1764-MM2RTC is -40°C to +40°C (-40°F to +104°F). Battery life is significantly shorter at elevated temperatures.

Processors



In the controller system, the processor unit provides logic processing, trim potentiometers, Run/Remote/Program mode switch, communications toggle push button and (using the 1764-LRP processor) an electrically isolated RS-232 port. The processor also provides the interface to the DAT, real-time clock, and memory modules.

There are two processor units: 1764-LSP and 1764-LRP.

Data Access Tool (1764-DAT)



The DAT plug-in tool provides an interface for on-the-fly data monitoring and adjustments. The DAT has five primary features:

- Direct access to 48 bit elements
- Direct access to 48 integer elements
- Two function keys
- Display of controller faults
- Removal and insertion under power

Real-Time Clock and Memory Modules

These optional modules attach to the processor unit. Both types of modules can be inserted or removed while the unit is under power.



Real-Time Clock Modules

Real-time clock modules establish a time-base for controller functions that need to be coordinated with real-time events. They provide year, month, day of month, day of week, hour, minute, and second information to the controller using the RTC function file.

Memory Modules

Memory modules allow:

- user programs and data to be stored as backup
- transport programs for use with other controllers
- safety/security for press control and other critical applications
- auto recovery, through a power cycle, after a controller fault
- comparison of programs
- Data file and memory module write protection

Table 10 Memory and Real-Time Clock Modules

Catalog Number	Function	Memory
1764-RTC	Real-Time Clock	not applicable
1764-MM1	Memory Module	8K
1764-MM1RTC	Memory Module and Real-Time Clock	8K
1764-MM2 ⁽¹⁾	Memory Module	16K
1764-MM2RTC ⁽¹⁾	Memory Module and Real-Time Clock	16K

(1) For the 1764-LRP processor to support larger program and data requirements.

MicroLogix 1500 System Expansion

To increase your I/O options, you can connect an additional bank of I/O to your MicroLogix 1500 controller.

In a MicroLogix 1500 system, a maximum of one 1769 Expansion cable can be used, allowing for two banks of I/O modules (one connected directly to the controller and the other connected via the cable). Each I/O bank⁽¹⁾ requires its own power supply (Bank 0 uses the controller's embedded power supply).

Only one power supply (embedded or expansion) may be used on an I/O bank. The expansion power supply cannot be connected directly to a controller. It must be connected using one of the expansion cables.

Vertical Orientation

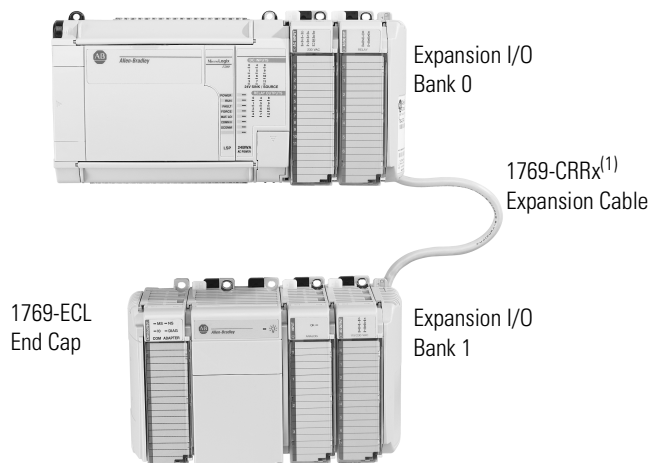

Horizontal Orientation

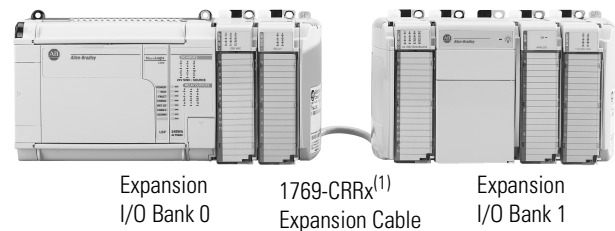

(1) The x in this catalog number can be either a 1 or a 3 representing the length of the cable: 1 = 1 foot (305 mm) and 3 = 3.28 feet (1 meter).

The following section of this document, Compact Expansion I/O, provides information for choosing Compact I/O expansion options.

Basically, you select the I/O options you need and then verify that the selections do not exceed the available power in the system. As shown above, the power can be provided from the Base Unit or an expansion power supply.

After reviewing the I/O options, use the worksheets in the “System Expansion Calculations” section on page 22 to list your I/O choices and determine the system power requirements. The worksheets will let you know if the system is within allowable limits.

A download is also available for system validation. On the Internet, go to <http://www.ab.com/micrologix> and navigate to MicroLogix 1500.

(1) An I/O bank is a group of I/O modules connected directly to one another. Banks are separated by cables.

Compact Expansion I/O



High-density Bulletin 1769 Compact I/O rackless expansion modules offer superior functionality and high value at a competitive price. With a variety of modules, they complement and extend the capabilities of the MicroLogix 1500 controller by maximizing flexibility of the I/O count and type.

Up to 16 modules can be used in a MicroLogix 1500 system when using a Series B Base Unit (up to 8 for Series A) dependent on power requirements. In addition to staying within the power limits, the modules must be distributed within the system using the following limitations:

- a maximum of 8 modules can be connected directly to the Base Unit
- a maximum of 8 modules can be connected to each side of the Expansion Power Supply

Compact I/O provides an excellent platform for future enhancements, so you can easily choose the level of control as your application needs grow.

Advantages

- Modular system
- Feature-rich I/O to address a wide range of applications
- Rackless design reduces system components
- Small footprint shrinks panel space requirements
- Front insertion and removal reduces assembly and replacement time
- Unique tongue-and-groove interlocking case design ensures a strong, mechanical connection between modules
- Software keying prevents incorrect module placement within a system
- Digital I/O modules available with AC/DC relay, 24V dc, and 120/240V ac voltages
- Analog I/O modules configurable for voltage or current
- Thermocouple, RTD, and High-Speed Counter input modules
- DeviceNet scanner communications module

Digital I/O Modules

Table 11 Compact Digital Input Modules⁽¹⁾ Selection Chart

Catalog Number	Description	Voltage Category	Number of Inputs	Commons per Module	Bus Current Draw (max.)
1769-IA16	AC	100/120V ac	16	1	115 mA at 5V dc
1769-IA8I	AC	100/120V ac	8	8	90 mA at 5V dc
1769-IM12	AC	200/240V ac	12	1	100 mA at 5V dc
1769-IQ16	DC (sink/source)	24V dc	16	2	115 mA at 5V dc

(1) Power Supply Distance Rating = 8. The maximum distance an I/O module may be located from the power supply is 8 modules.

Table 12 Compact Digital Output Modules⁽¹⁾ Selection Chart

Catalog Number	Description	Voltage Category	Number of Outputs	Commons per Module	Continuous Current per Point (max.)	Bus Current Draw (max.)
1769-OA8	AC	120/240V ac	8	2	0.25A at 60°C (140°F) 0.5A at 30°C (86°F)	145 mA at 5V dc
1769-OA16 ⁽²⁾	AC	120/240V ac	16	2	0.25A at 60°C (140°F) 0.5A at 30°C (86°F)	225 mA at 5V dc
1769-OB16	DC (source)	24V dc	16	1	0.5A at 60°C (140°F) 1.0A at 30°C (86°F)	200 mA at 5V dc
1769-OB16P	DC (source) with Electronic Protection	24V dc	16	1	0.5A at 60°C (140°F) 1.0A at 30°C (86°F)	160 mA at 5V dc
1769-OV16	DC (sink)	24V dc	16	1	0.5A at 60°C (140°F) 1.0A at 30°C (86°F)	200 mA at 5V dc
1769-OW8	AC/DC Relay	5 to 265V ac 5 to 125V dc	8	2	2.5A, Also see Table 8, Relay Contact Ratings on page 7.	125 mA at 5V dc 100 mA at 24V dc
1769-OW8I	AC/DC Relay	5 to 265V ac 5 to 125V dc	8	8		125 mA at 5V dc 100 mA at 24V dc
1769-OW16 ⁽²⁾	AC/DC Relay	5 to 265V ac 5 to 125V dc	16	2		205 mA at 5V dc 180 mA at 24V dc

(1) Power Supply Distance Rating = 8. The maximum distance an I/O module may be located from the power supply is 8 modules.

(2) Dimensionally one and one-half as wide as other modules.

Table 13 Compact Combination Input and Output Module⁽¹⁾ Selection Chart

Catalog Number	Description	Voltage Category	Number of Points	Commons per Module	Continuous Current per Point (max.)	Bus Current Draw (max.)
1769-IQ6XOW4	DC (sink/source) inputs	24V dc	6 inputs	2 (one for inputs, one for outputs)	n/a	105 mA at 5V dc
	AC/DC Relay outputs	5 to 265V ac 5 to 125V dc	4 outputs		2.5A	50 mA at 5V dc

(1) Power Supply Distance Rating = 8. The maximum distance an I/O module may be located from the power supply is 8 modules.

Analog I/O Modules

Table 14 Compact Analog I/O Modules⁽¹⁾ Selection Chart

Catalog Number	Description	Input Channels per Module	Output Channels per Module	Bus Current Draw (max.)
1769-IF4	14-bit current/voltage input module	4 differential or single-ended	n/a	120 mA at 5V dc 60 mA at 24V dc
1769-OF2	14-bit current/voltage output module	n/a	2 single-ended	120 mA at 5V dc 120 mA at 24V dc
1769-IF4XOF2	8-bit combination input/output module	4 differential or single-ended	2 single-ended	120 mA at 5V dc 160 mA at 24V dc

(1) Power Supply Distance Rating = 8. The maximum distance an I/O module may be located from the power supply is 8 modules.

Temperature Input Modules

Table 15 Compact Temperature Input Modules⁽¹⁾ Selection Chart

Catalog Number	Description	Input Channels per Module	Bus Current Draw (max.)
1769-IT6	supports thermocouple and millivolt signal measurement	6 input channels plus 2 CJC sensors	100 mA at 5V dc 40 mA at 24V dc
1769-IR6	supports RTD and direct resistance signal measurement	6 input channels	100 mA at 5V dc 45 mA at 24V dc

(1) Power Supply Distance Rating = 8. The maximum distance an I/O module may be located from the power supply is 8 modules.

High-Speed Counter Module

The 1769-HSC is a 1 MHz counter/encoder module with 4 on-board outputs and 12 virtual outputs. Use this module for high-speed control applications such as flow control, or measuring length, position, speed, frequency or duration. The module can simultaneously interface with up to 2 quadrature incremental encoders or 4 single-input counters.

Table 16 Compact High-Speed Counter Module Selection Chart⁽¹⁾

Catalog Number	Description	Input Channels per Module	Output Channels per Module	Bus Current Draw (max.)
1769-HSC	1 MHz High-Speed Counter/Encoder Module	(4) single-input counters, or (2) quadrature (ABZ) differential inputs -30 to +30V dc	(4) 5 to 30V dc sourcing outputs	425 mA at 5V dc

(1) Power Supply Distance Rating = 4. The maximum distance an I/O module may be located from the power supply is 4 modules.

DeviceNet Scanner Communications Module

Via the 1769-SDN, a MicroLogix 1500 controller can act as a DeviceNet master, slave, or peer. The 1769-SDN provides standard DeviceNet master functionality, as well as several new performance and ease-of-use features. You can message between devices using one of two methods (PCCC and Explicit messaging), and perform program upload, download, and monitoring through the scanner.

Table 17 Compact DeviceNet Scanner Module⁽¹⁾ Selection Chart

Catalog Number	Description	Bus Current Draw (max.)
1769-SDN	DeviceNet Scanner Module	440 mA at 5V dc

(1) Power Supply Distance Rating = 4. The maximum distance an I/O module may be located from the power supply is 4 modules.



Power Supplies, Expansion Cables, and End Caps

Power Supplies

Using an expansion I/O power supply increases the system's capacity for adding expansion I/O modules.

Table 18 Compact Power Supplies Specifications

Specification	1769-PA2	1769-PB2	1769-PA4	1769-PB4
Power Supply Voltage	85 to 265V ac (no jumper or DIP switch required) 47 to 63 Hz	19.2 to 31.2V dc	85 to 132V ac (170 to 265 or switch selectable)	19.2 to 31.2V dc
Power Consumption (max.)	100 VA at 120V ac 130 VA at 240V ac	50 VA at 24V dc	200 VA at 120V ac 240 VA at 240V ac	100 VA at 24V dc
Power Supply Inrush Current (max.)	25A at 132V ac 40A at 240V ac	30A at 31.2V dc	25A at 132V ac 40A at 240V ac	30A at 31.2V dc
Maximum Load Current	2A at 5V dc 0.8A at 24V dc	2A at 5V dc 0.8A at 24V dc	4A at 5V dc 2A at 24V dc	4A at 5V dc 2A at 24V dc
24V dc Sensor Power	250 mA (max.) at 55°C (131°F)	n/a	n/a	n/a

Expansion Cables

Expansion cables are required when adding a second bank of I/O modules. They are connected from the right side of the controller bank to either the left or right side of the expansion bank.



Table 19 Compact Expansion Cables Selection Chart

Cable Type	Length	Catalog Number
right bank-to-right bank	305 mm (1 ft)	1769-CRR1
right bank-to-right bank	1m (3.28 ft)	1769-CRR3
right bank-to-left bank	305 mm (1 ft)	1769-CRL1
right bank-to-left bank	1m (3.28 ft)	1769-CRL3

End Caps

In every expansion I/O system, an end cap must be used to terminate the end of the serial communication bus. The end cap is connected to the last I/O module in the system.

Table 20 Compact End Caps Selection Chart

End Cap	Catalog Number
right end cap	1769-ECR
left end cap	1769-ECL

Communications

MicroLogix 1500 Communications Advantages

- Enhanced RS-232 port (includes 24V dc power for network interface devices)
- 300; 600; 1200; 4800; 9600; 19,200 and 38,400 baud rates
- RTS/CTS hardware handshake signals
- Connection to DH-485, DeviceNet and Ethernet networks through the 1761-NET-AIC, 1761-NET-DNI and 1761-NET-ENI interface modules
- Connection to modems for remote communications
- ASCII messaging provides dial-out capability

The MicroLogix 1500 allows you to choose the network that best meets your needs.

Table 21 MicroLogix 1500 Network Options

If your application requires:	Use this network:
<ul style="list-style-type: none"> • Connection to dial-up modems for remote program maintenance or data collection • Connection to leased-line or radio modems for use in SCADA systems • Remote Terminal Unit (RTU) functions 	DF1 Full-Duplex DF1 Half-Duplex Slave
<ul style="list-style-type: none"> • Plant-wide and cell-level data sharing with program maintenance • Data sharing between 32 controllers • Program upload, download, and monitoring to all controllers • Compatibility with multiple Allen-Bradley HMI devices 	DH-485 via the 1761-NET-AIC
<ul style="list-style-type: none"> • Connection of low-level multi-vendor devices directly to plant floor controllers • Data sharing between 64 devices • Better diagnostics for improved data collection and fault detection • Less wiring and reduced start-up time than traditional, hard-wired systems 	DeviceNet via the 1761-NET-DNI
<ul style="list-style-type: none"> • Program upload/download • Peer-to-peer communication • E-mail communication • 10 base T-port with embedded LEDs 	EtherNet/IP via the 1761-NET-ENI
<ul style="list-style-type: none"> • Connection to modems for remote data collection in a SCADA system • Remote Terminal Unit (RTU) functions 	Modbus RTU Slave

The following section provides information about the network interface devices:

- AIC+ Advanced Interface Converter (1761-NET-AIC)
- DNI DeviceNet Interface (1761-NET-DNI)
- ENI Ethernet Interface (1761-NET-ENI)

Network Interface Devices

The network interface devices can be mounted on a panel or DIN rail. See Figure 28 on page 19 for device drawings.

AIC+ Advanced Interface Converter (1761-NET-AIC)

The AIC+ provides an interface to DH-485 networks from an RS-232 port. It can be used with all MicroLogix controllers, SLC 5/03 and higher, and a number of PanelView terminals. *All devices communicating on the network must be using DH-485 protocol. Do not use DH-485 protocol to communicate with modems.*

The AIC+ also provides isolation between all ports for a more stable network and protection for connected devices.

Table 22 DH-485 Network Specifications⁽¹⁾

Specification	1761-NET-AIC
Maximum Number of Nodes	32 per multidrop network
Maximum Length	1219m (4000 ft) per multidrop network

(1) See Table 25, Network Modules Specifications, for more 1761-NET-AIC specifications.

DNI DeviceNet Interface (1761-NET-DNI)

DNI capabilities:

- Peer-to-peer messaging between Allen-Bradley controllers and other devices using the DF1 Full-Duplex protocol
- Programming and on-line monitoring over the DeviceNet network
- With a DNI connected to a modem, you can dial in to any other DNI-controller combination on DeviceNet
- Other DeviceNet products can send explicit (Get or Set) messages with the DNI at any time
- The controller can initiate an explicit message to a UCMM (Unconnected Message Manager) compatible device on DeviceNet

Table 23 DeviceNet Specifications⁽¹⁾

Specification	1761-NET-DNI
Maximum Number of Nodes	64
Maximum Length	500m at 125K baud or 100m at 500K baud
DeviceNet Agency Certification	ODVA conformance 2.0-A12

(1) See Table 25, Network Modules Specifications, for more 1761-NET-DNI specifications.

ENI Ethernet Interface (1761-NET-ENI)

The ENI provides EtherNet/IP connectivity for all MicroLogix controllers and other DF1 Full-Duplex devices. The ENI allows you to easily connect a MicroLogix controller to a new or existing Ethernet network to update/download programs, communicate between controllers, and generate e-mail messages via SMTP (simple mail transport protocol).



Table 24 Ethernet Specifications⁽¹⁾

Specification	1761-NET-ENI
Communication Rate	10 MHz
Connector	10Base-T (RJ45)

(1) See Table 25, Network Modules Specifications, for more 1761-NET-ENI specifications.

AIC+, DNI, and ENI Specifications

Table 25 Network Modules Specifications

Specification	1761-NET-AIC	1761-NET-DNI	1761-NET-ENI
24V dc Power Source Requirements ⁽¹⁾	20.4 to 28.8V dc	11 to 25V dc	20.4 to 26.4V dc
24V dc Current Draw	120 mA	200 mA	100 mA
Inrush Current (max.)	200 mA	400 mA	200 mA
Internal Isolation	500V dc for 1 minute	500V dc for one minute	710V dc for one minute
Operating Temperature	0°C to +60°C (+32°F to +140°F)		(0°C to +55°C (+32°F to +131°F))
Storage Temperature	-40°C to +85°C (-40°F to +185°F)		
Humidity	5% to 95% non-condensing		
Vibration	operating: 10 to 500 Hz, 5.0g, 0.030 in. peak-to-peak, 2 hour each axis	operating: 5 to 2000 Hz, 2.5g, 0.015 in. peak-to-peak, 1 hour each axis non-operating: 5 to 2000 Hz, 5.0g, 0.030 in. peak-to-peak, 1 hour each axis	operating: 10 to 500 Hz, 5.0g, 0.030 in. peak-to-peak, 2 hour each axis
Shock	operating: 30g, ±3 times each axis non-operating: 50g, ±3 times each axis	operating: 30g, ±3 times each axis non-operating: 50g, ±3 times each axis	operating: 30g, ±3 times each axis non-operating: 35g (DIN rail mount) 50g (panel mount) ±3 times each axis
Agency Certification	 UL Listed Industrial Control Equipment UL Listed Industrial Control Equipment for use in Canada UL Listed Industrial Control Equipment for use in Class I, Division 2 Hazardous Locations Groups A, B, C, D  Marked for all applicable directives  Marked for all applicable acts		

(1) When the device is connected to a MicroLogix controller, power is provided by the MicroLogix controller's communication port.

Programming Instructions

The MicroLogix 1500 has the range of functionality necessary to address diverse applications. The controller uses the following types of instructions:

- Basic Instructions
- Comparison Instructions
- Data Instructions
- Communication Instruction, including ASCII
- Math Instructions
- Program Flow Control Instructions
- Application Specific Instructions
- High-Speed Counter Instruction
- High-Speed PTO (Pulse Train Output) and PWM (Pulse Width Modulated) Instructions
- Recipe Instruction
- Data Logging Instruction (1764-LRP only)

Programming Software

The RSLogix 500 ladder logic programming package helps you maximize performance, save project development time, and improve productivity. This product has been developed to operate on Windows[®] operating systems. RSLogix 500 can be used for programming both the SLC 500 and MicroLogix controller families.

Table 26 RSLogix 500 Selection Chart

Catalog Number	Description
9324-RL0300ENE	RSLogix 500 Standard Edition Programming Software for SLC 500 and MicroLogix controller families. (CD-ROM)
9324-RL0100ENE	RSLogix 500 Starter Edition Programming Software for MicroLogix controller families. (CD-ROM)
9324-RL0700NXENE	RSLogix 500 Professional Edition. CD-ROM also includes RSLogix Emulate 500, RSNetworx for DeviceNet and RSNetworx for ControlNet.

Network and Programming Cables

Use the communication cables listed below with MicroLogix 1500 controllers. Cables come in several lengths and connector styles to provide connectivity between MicroLogix controllers and other devices.

MicroLogix 1500 controllers require Series C versions of all 1761 cables.

Table 27 Controller and PC Port Identification

Device	Port
MicroLogix 1500 Base Unit Communications Port	8-pin Mini DIN
MicroLogix 1500 LRP Processor Communications Port	9-Pin D Shell
Personal Computer Communications Port	9-Pin D Shell

Figure 28 Network Interface Devices Communication Port Identification

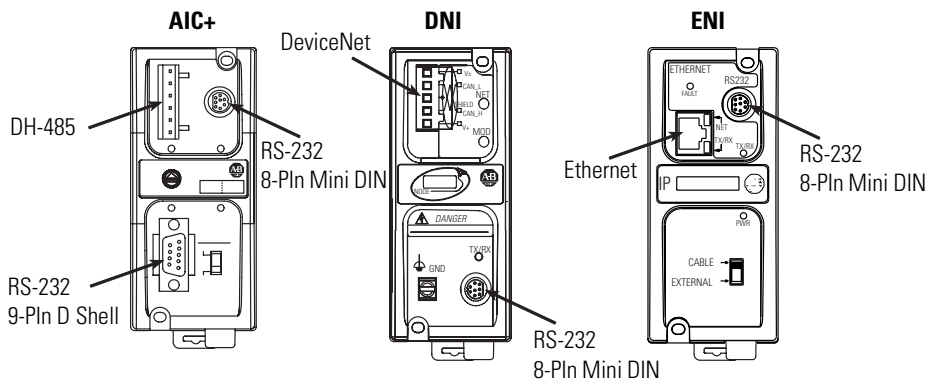

Table 29 Network Cable Selection Chart

Connectors	Length	Catalog Number	Connectors	Length	Catalog Number
8-pin Mini DIN to 8-pin Mini DIN	0.5m (1.5 ft)	1761-CBL-AM00	8-pin Mini DIN to 9-pin D Shell	0.5m (1.5 ft)	1761-CBL-AP00
8-pin Mini DIN to 8-pin Mini DIN	2m (6.5 ft)	1761-CBL-HM02	8-pin Mini DIN to 9-pin D Shell	2m (6.5 ft)	1761-CBL-PM02
8-pin Mini DIN to 8-pin Mini DIN	5m (16 ft)	2711-CBL-HM05	8-pin Mini DIN to 9-pin D Shell	5m (16 ft)	2711-CBL-PM05
8-pin Mini DIN to 8-pin Mini DIN	10m (32 ft)	2711-CBL-HM10	8-pin Mini DIN to 9-pin D Shell	10m (32 ft)	2711-CBL-PM10
9-pin D Shell to 9-pin D Shell	0.5m (1.5 ft)	1761-CBL-AC00	6-pin Phoenix to RJ45 (DH-485)	3m (10 ft)	1761-CBL-AS03
9-pin D Shell to 9-pin D Shell	3m (10 ft)	1747-CP3	6-pin Phoenix to RJ45 (DH-485)	9m (30 ft)	1761-CBL-AS09

Table 30 Programming Cable Selection Chart

MicroLogix 1000, 1200, and 1500 Channel 0 (8-pin Mini DIN)		MicroLogix 1500 with 1764-LRP Processor Channel 1 (9-pin RS-232)		Programming Device
Catalog Number	Length	Catalog Number	Length	
1761-CBL-PM02	2m (6.5 ft)	1747-CP3	3m (10 ft)	Personal Computer (9-pin D Shell)
1761-CBL-HM02	2m (6.5 ft)	n/a		Hand-Held Programmer (HHP)

Dimensions

NOTE: All dimensions are in mm (inches). Hole spacing tolerance: ± 0.04 mm (0.016 in.).

Figure 31 Compact I/O with MicroLogix 1500 Base Unit and Processor

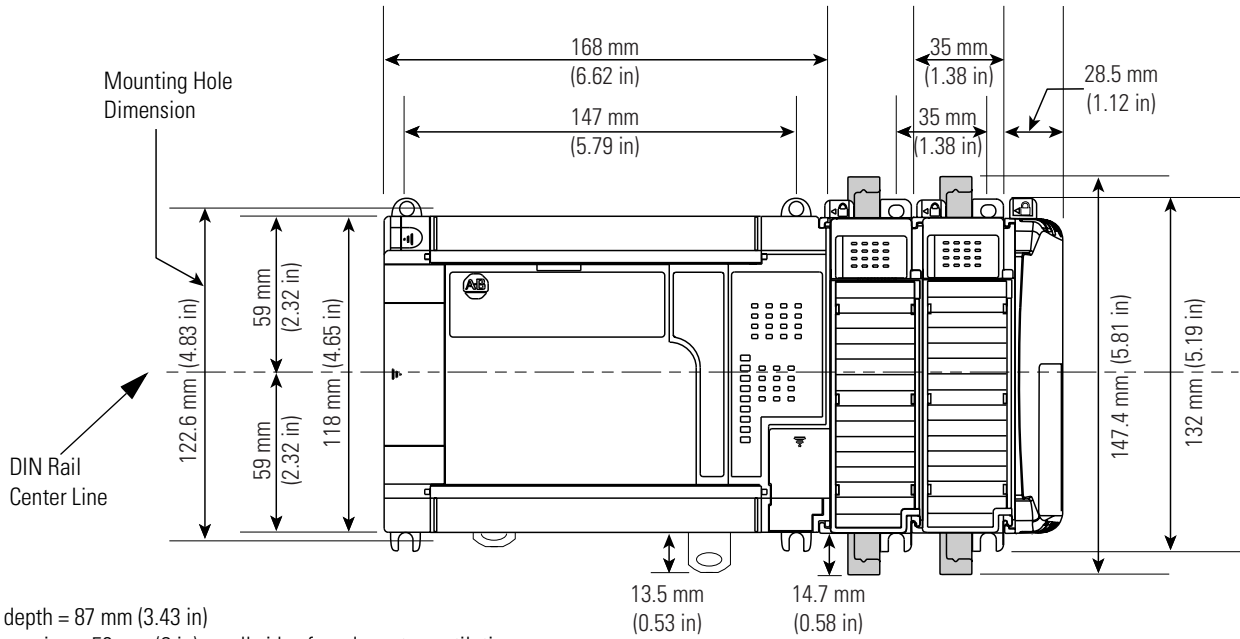

Figure 32 Expansion Bank with Power Supply, Expansion Cable, and End Cap

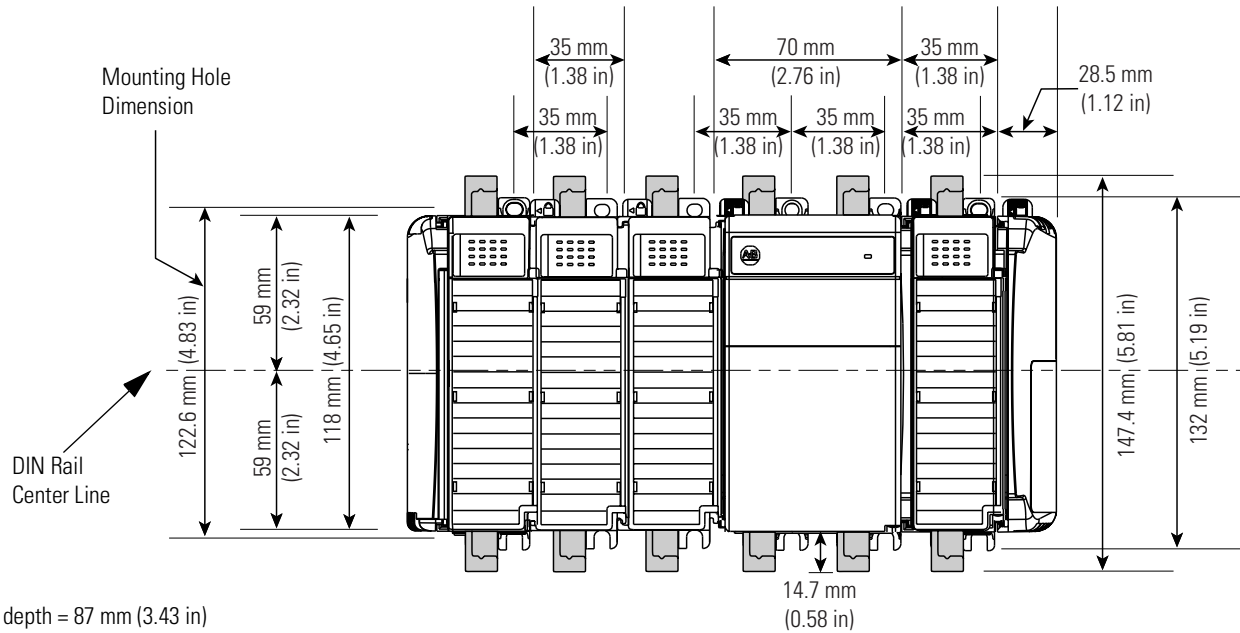
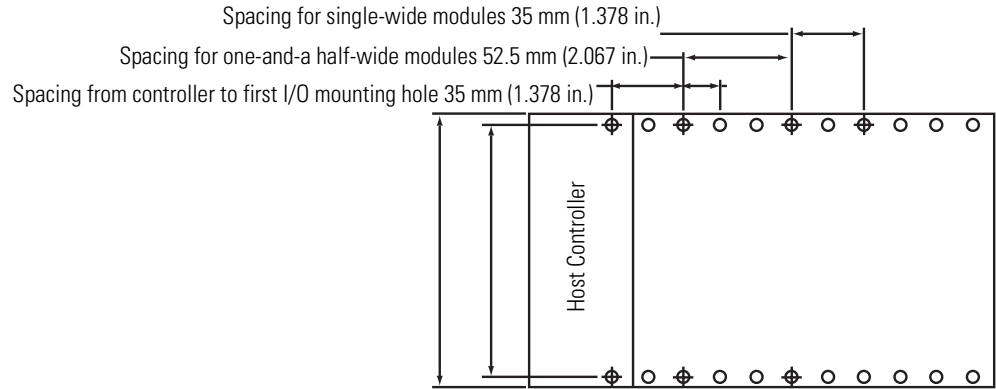

Figure 33 Spacing for Single-Wide and One and One-Half-Wide Modules

Panel Mounting Using the Dimensional Template:



Note: Overall hole spacing tolerance: ± 0.4 mm (0.016 in.).

Locate holes every 17.5 mm (0.689 in.) to allow for a mix of single-wide (e.g. 1769-IQ16) and one-and-one-half-wide modules (e.g. 1769-OA16).

Figure 34 Network Interface Devices Dimensions

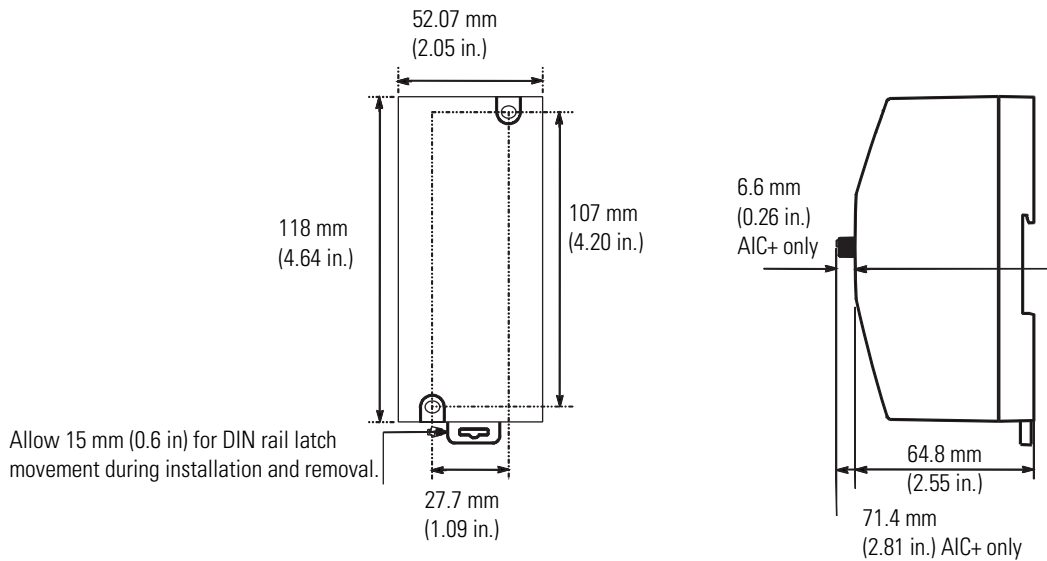

System Expansion Calculations

A download is also available for system validation. On the Internet, go to <http://www.ab.com/micrologix> and navigate to MicroLogix 1500.

The procedure in this publication consists of:

- Selecting System Devices
- Verifying the System Loading
- Selecting Expansion Cables and End Caps

Selecting System Devices

1. Use Table 35 to select the processor and optional communications or display devices. Enter a 1 in the “Select Devices” column.
2. Enter the current draw values in the “Calculated Current for System” columns. If an external power supply will be used to power communication devices, do not include their current draw values in this calculation. Add up the current draw values to determine the “SUBTOTAL1” values.

Table 35 Selecting Hardware: Base Unit and Communications/Display Devices

Catalog Number	Select Device(s)	Bus Current Draw Specification		Calculated Current for System	
		at 5V dc (mA)	at 24V dc (mA)	at 5V dc (mA)	at 24V dc (mA)
<i>Choose a Processor, LSP or LRP:</i>					
1764-LSP		300	0		
1764-LRP		380	0		
1764-DAT ⁽¹⁾ optional		350	0		
<i>Communications/Display Devices, optional, one only maximum:</i>					
1761-NET-AIC ⁽¹⁾		0	120 ⁽²⁾		
1761-NET-ENI ⁽¹⁾		0	100 ⁽²⁾		
2707-MVH232 or 2707-MVP232 ⁽¹⁾		0	80 ⁽²⁾		
SUBTOTAL1				(A1)	(B1)

(1) These are optional accessories. Current is consumed only if the accessory is installed.

(2) Current for the AIC+ and ENI may be supplied by controller communications port or from an external 24V dc source. No current is consumed from the controller when a user-supplied, external source is used. If an external source is to be used, do not select the device here. The current for a 2707-MVH232 or 2707-MVP232 MicroView Operator Interface is supplied from the controller communication port, when directly connected.

3. Use Table 36 to select the I/O modules. Enter the number of modules in either the “Base Unit Expansion” or the “Bank 1” column.

IMPORTANT

When planning the system layout, keep in mind that each module has a “Power Supply Distance Rating”. This is the maximum distance an I/O module may be located from the power supply. For most modules, the rating is 8. For the 1769-HSC and 1769-SDN, the rating is 4.

Depending on its configuration, the 1769-SDN may transfer large amounts of data into and out of the controller I/O image tables. Care should be taken when using more than three of these modules to verify that they are optimally configured. This will ensure that the maximum available 4K data table size will not be exceeded. Refer to the 1769-SDN User Manual for more details.

4. Enter the current draw values in the “Calculated Current” columns. Add up the current draw values to determine the “SUBTOTAL2” values.
5. Verify that the total number of modules does not exceed the system limits.

Table 36 Selecting Hardware: Expansion I/O

<i>Select I/O Modules for Each Bank:</i>			Bus Current Draw Specification (mA)		<i>Calculate Current Draw:</i>			
Expansion I/O Modules	Base Unit Expansion	Bank 1			Calculated Current for Base Unit Expansion (mA)		Calculated Current for Bank 1 Power Supply (mA)	
	n1	n2	X	Y	n1 x X	n1 x Y	n2 x X	n2 x Y
Catalog Number	Number of Modules⁽¹⁾		at 5V dc	at 24V dc	at 5V dc	at 24V dc	at 5V dc	at 24V dc
1769-IA16			115	0				
1769-IA8I			90	0				
1769-IF4 (Series A)			120	150				
1769-IF4 (Series B)			120	60				
1769-IF4XOF2			120	160				
1769-IM12			100	0				
1769-IQ16			115	0				
1769-IQ6XOW4			105	50				
1769-IR6			100	45				
1769-IT6			100	40				
1769-OA8			145	0				
1769-OA16			225	0				
1769-OB16			200	0				
1769-OB16P			160	0				
1769-OF2 (Series A)			120	200				
1769-OF2 (Series B)			120	120				
1769-OV16			200	0				
1769-OW8			125	100				
1769-OW8I			125	100				
1769-OW16			205	180				
1769-HSC			425	0				
1769-SDN			440	0				
TOTAL MODULES:			SUBTOTAL2:		(A2)	(B2)	(C)	(D)

(1) Up to 16 modules may be used in a MicroLogix 1500 system when using a Series B Base Unit and Series C processor (up to 8 for Series A Base Units).

A maximum of 8 modules can be connected directly to the Base Unit.

A maximum of 8 modules can be connected to each side of the Expansion Power Supply.

Verifying the System Loading

To have a valid system, both current and power requirements must be satisfied.

Verifying the Base Unit Loading

1. Enter the SUBTOTAL values from Tables 35 and 36. Add the total current draw for the Base Unit. Verify the values are within the maximum limits.

Table 37 Base Unit Power Supply Loading - Verify the Current Limits

Current from:	Calculated Current for System	
	at 5V dc (mA)	at 24V dc (mA)
For 1764-24BWA only, enter sum of any User 24V dc Sensor Current		(E)
MAXIMUM LIMIT		400 mA User 24V dc
Values from SUBTOTAL1	(A1)	(B1)
Values from SUBTOTAL2	(A2)	(B2)
TOTAL BASE UNIT CURRENT LOADING	(F)	(G)
MAXIMUM LIMIT	2250 mA at 5V dc	400 mA at 24V dc

2. Using the table below, verify that the MAXIMUM POWER LIMIT is not exceeded.

Table 38 Base Unit Power Supply Loading - Verify the Required Power

Catalog Number:	1764-24AWA, 1764-28BXB			1764-24BWA		
5V Power Calculation	(F)	x 5V	= W	(F)	x 5V	= W
24V Power Calculation	(G)	x 24V	= W	(G)	x 24V	= W
				(E)	x 24V	= W
Add up Total Watts			W			W
MAXIMUM POWER LIMIT			16W			22W

Verifying the Expansion Power Supply Loading

Using the values from SUBTOTAL2, verify that the system loading and I/O distribution are within the limits shown in Table 39. Consider future expansion when selecting a power supply.

Table 39 Bank 1 Power Supply Loading - Verify the Current Limits

Specification	Catalog Number	Calculated Current for System		24V dc User Output Capacity
		at 5V dc (mA)	at 24V dc (mA)	
Values from SUBTOTAL2 (on page 23):		(C)	(D)	
MAXIMUM CURRENT LIMIT	1769-PA2	2000	800	250 mA
	1769-PA4	4000	2000	n/a
	1769-PB2	2000	800	
	1769-PB4	4000	2000	
I/O Distribution - Distribute I/O modules such that the current consumed from either the left side or the right side of the power supply never exceeds the following values:	1769-PA2	2000	800	250
	1769-PA4	2000	1000	
	1769-PB2	2000	800	
	1769-PB4	2000	1000	

Selecting Expansion Cables and End Caps

Any system using Compact I/O must have an end cap. If I/O Bank 1 is used, an expansion cable is also required. Use the information on page 14 to make your selection and complete the table below.

Table 40 Select End Cap and Expansion Cable

Type of System	Requirement	Catalog Number Selected
Base Unit with Compact I/O only	right end cap	1769-ECR
Base Unit with Compact I/O and Bank 1, horizontal orientation	right-to-left expansion cable	
	right end cap	1769-ECR
Base Unit with Compact I/O and Bank 1, vertical orientation	right-to-right expansion cable	
	left end cap	1769-ECL

For More Information

Available Documentation

MicroLogix 1500 user documentation presents information according to the tasks you perform and the programming environment you use. Refer to the table below for information on MicroLogix 1500 publications.

Table 41 Related Publications for MicroLogix 1500 Controllers

Title	Publication Number
MicroLogix 1500 Programmable Controllers User Manual	1764-UM001
MicroLogix 1200 and MicroLogix 1500 Instruction Set Reference Manual	1762-RM001
Compact I/O System Overview	1769-SO001
1769 Compact I/O Power Supplies and Communication Bus Expansion Cables Technical Data	1769-TD001
Compact Analog I/O and Temperature Input Modules Technical Data	1769-TD004
Compact I/O Analog Modules User Manual	1769-UM002
Compact I/O 1769-IT6 Thermocouple/mV Input Module User Manual	1769-UM004
Compact I/O 1769-IR6 RTD/Resistance Input Module User Manual	1769-UM005
Compact 1769-HSC High Speed Counter Module User Manual	1769-UM006
Compact 1769-SDN DeviceNet Scanner Module User Manual	1769-UM009
AIC+ Advanced Interface Converter User Manual	1761-6.4
DeviceNet Interface User Manual	1761-6.5
Ethernet Interface User Manual	1761-UM006
Allen-Bradley Programmable Controller Grounding and Wiring Guidelines	1770-4.1

If you would like a technical data for the MicroLogix 1000 or MicroLogix 1200 controllers, refer to the following table.

Table 42 MicroLogix 1000 and 1200 Technical Data Publications

See this Document	Publication Number
MicroLogix 1000 Technical Data	1761-TD001
MicroLogix 1200 Technical Data	1762-TD001

MicroLogix Downloads

Visit the MicroLogix web site at <http://www.ab.com/micrologix> to learn more about MicroLogix products and download MicroLogix software utilities and manuals. Software utilities are available for configuring the DNI and ENI network interface devices. System validation worksheets are available to determine I/O power usage.

Manuals are available in PDF format. To purchase a printed manual or download a free electronic version, visit us at <http://www.theautomationbookstore.com>. For fast access to related publications, visit the MicroLogix Internet site <http://www.ab.com/micrologix>. Electronic versions of our manuals are available for you to search and download.

Rockwell Software Web Site

For more information on Rockwell Software products, such as RSLogix 500, please visit their web site at <http://www.rockwellsoftware.com>.

Allen-Bradley, SLC, MicroLogix, Compact, RSLogix, RSNetwork, ControlNet, MicroView, and PanelView are trademarks of Rockwell Automation.
DeviceNet is a trademark of Open DeviceNet Vendors Association (ODVA).

www.rockwellautomation.com

Corporate Headquarters

Rockwell Automation, 777 East Wisconsin Avenue, Suite 1400, Milwaukee, WI, 53202-5302 USA, Tel: (1) 414.212.5200, Fax: (1) 414.212.5201

Headquarters for Allen-Bradley Products, Rockwell Software Products and Global Manufacturing Solutions

Americas: Rockwell Automation, 1201 South Second Street, Milwaukee, WI 53204-2496 USA, Tel: (1) 414.382.2000, Fax: (1) 414.382.4444

Europe: Rockwell Automation SA/NV, Vorstlaan/Boulevard du Souverain 36-BP 3A/B, 1170 Brussels, Belgium, Tel: (32) 2 663 0600, Fax: (32) 2 663 0640

Asia Pacific: Rockwell Automation, 27/F Citicorp Centre, 18 Whitfield Road, Causeway Bay, Hong Kong, Tel: (852) 2887 4788, Fax: (852) 2508 1846

Headquarters for Dodge and Reliance Electric Products

Americas: Rockwell Automation, 6040 Ponders Court, Greenville, SC 29615-4617 USA, Tel: (1) 864.297.4800, Fax: (1) 864.281.2433

Europe: Rockwell Automation, Brühlstraße 22, D-74834 Elztal-Dallau, Germany, Tel: (49) 6261 9410, Fax: (49) 6261 17741

Asia Pacific: Rockwell Automation, 55 Newton Road, #11-01/02 Revenue House, Singapore 307987, Tel: (65) 351 6723, Fax: (65) 355 1733

Publication 1764-TD001A-EN-P - March 2002

Supersedes Publication 1764-S0001B-EN-P - May 2000

Copyright © 2002 Rockwell Automation. All rights reserved. Printed in the U.S.A.