



WHEEL, HUB, AND SPINDLE TORQUE TABLE

Item	Specification
Front Wheel Nuts	20 Ft. Lbs. (27 Nm)
Rear Wheel Nuts	50 Ft. Lbs. (68 Nm)
Front Spindle Nut	40 Ft. Lbs. (54 Nm)
Rear Hub Retaining Nut	80 Ft. Lbs. (109 Nm)

NOTE: Refer to exploded views and text for torque values of other fasteners

CAUTION: Locking nuts and bolts with preapplied locking agent must be replaced if removed. The self-locking properties of the nut or bolt are reduced or destroyed during removal.

FRONT HUB DISASSEMBLY/INSPECTION

1. Elevate front end and safely support machine under footrest / frame area.

CAUTION: Serious injury may result if machine tips or falls. Be sure machine is secure before beginning this service procedure. Wear eye protection when removing bearings and seals.

2. Check bearings for side play by grasping tire / wheel firmly (top and bottom) and checking for movement. It should rotate smoothly without binding or rough spots.



3. Remove wheel nuts and wheel.

4. Remove the two brake caliper bolts and the brake caliper.

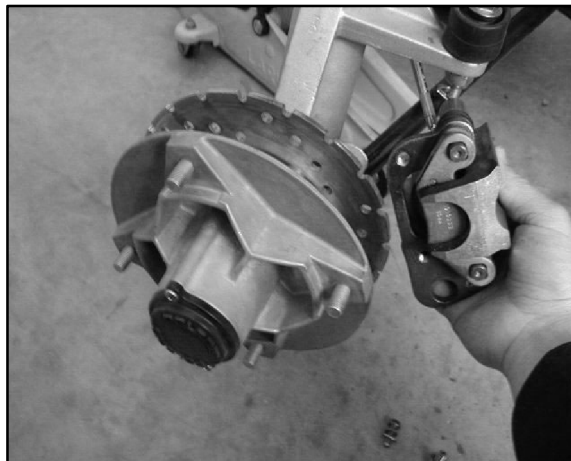

5. Remove hub cap, cotter pin, front spindle nut, and washer.
6. Rotate each bearing by hand and check for smooth rotation. Visually inspect bearing for moisture, dirt, or corrosion. Replace bearing if moisture, dirt, corrosion, or roughness is evident.
7. Place a shop towel on hub to protect surface. Carefully pry seal out of hub.

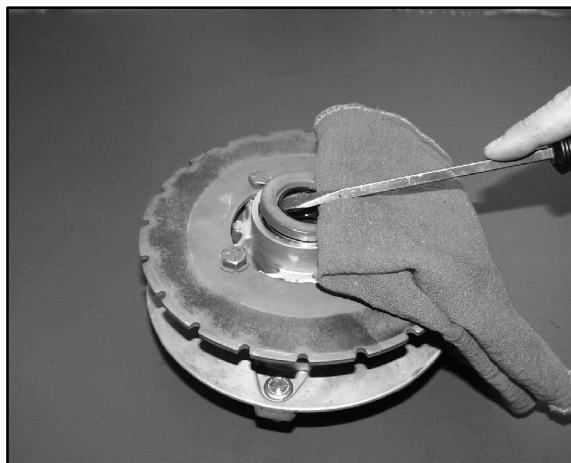



- Using a brass drift, tap bearing spacer to one side to expose inner bearing race. Drive bearing out using a drift through opposite side of hub and discard.

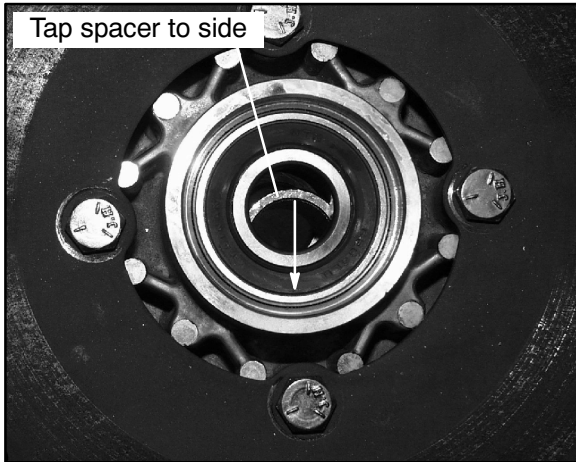

- Remove spacer and drive other bearing out and discard.
- Clean hub and spacer thoroughly.
- Inspect spacer for wear or damage. Measure length of spacer and replace if worn beyond service limit or if ends are rounded.

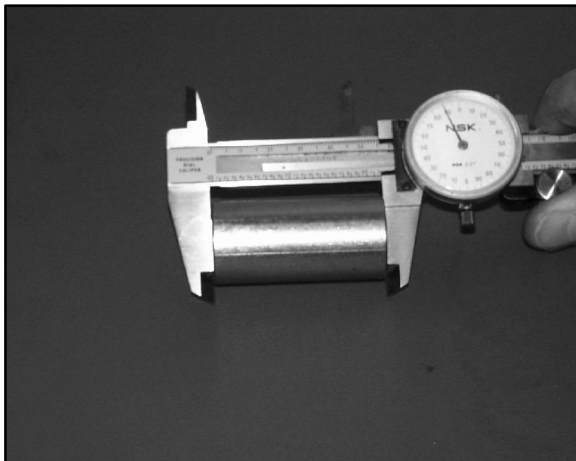

**Bearing Spacer Length:
Service Limit: 2.1850" (5.55 cm)**

FRONT HUB ASSEMBLY

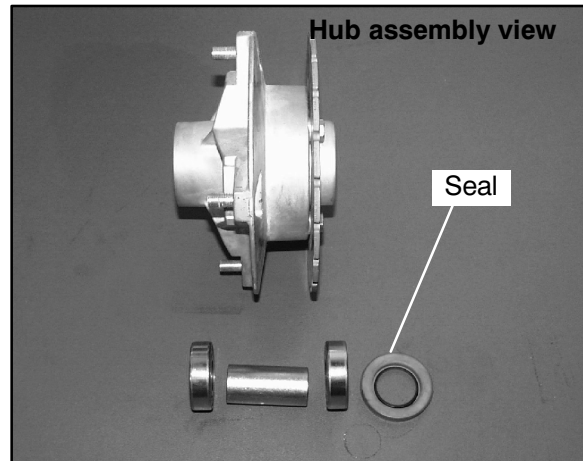

- Drive or press one new bearing into hub using a 1.180 (46 mm) bearing driver.

CAUTION: Do not drive on the inner race of the bearing.

Premium All-Season Grease
(PN 2871322) (3 oz. Tube)
(PN 2871423) (14 oz. Tube)

- Coat bearing spacer with grease and install into hub. Drive or press the other bearing into hub until seated against spacer.

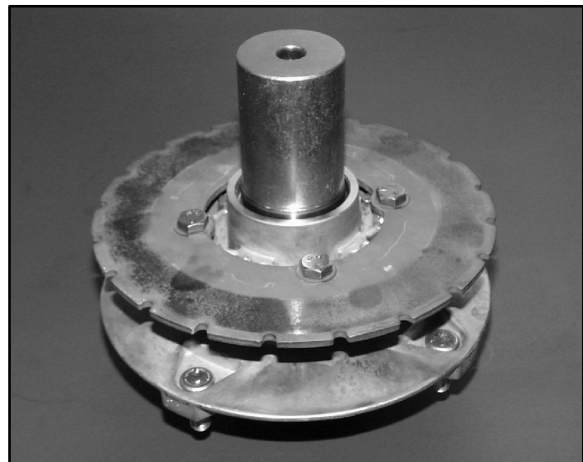

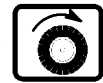

3. Install seal into hub (with numbers facing out) until flush with end of seal bore.

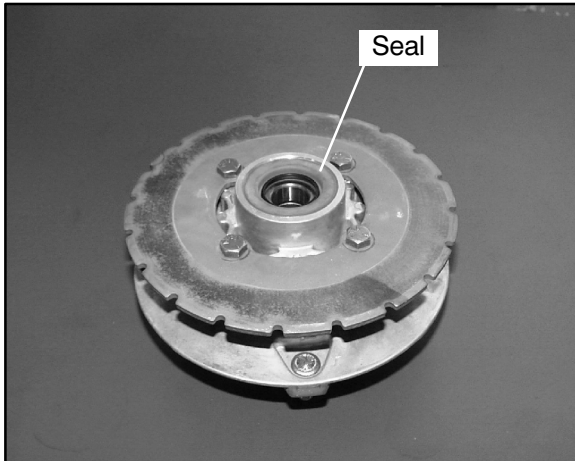

5. Install spindle nut and tighten to specification.

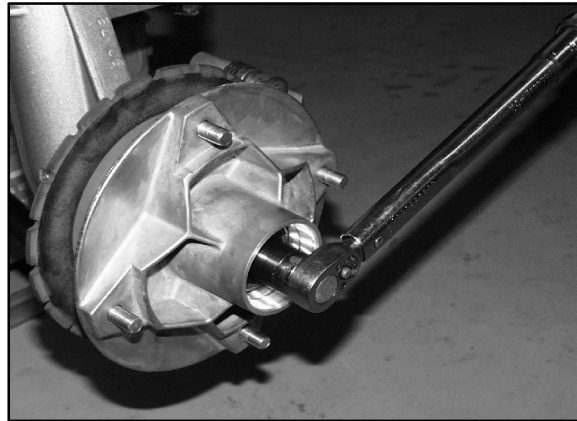

**2 x 4 Spindle Nut Torque:
40 ft. lbs. (55.0 Nm)**

FRONT HUB INSTALLATION

1. Inspect spindle seal and bearing surface for wear or damage.

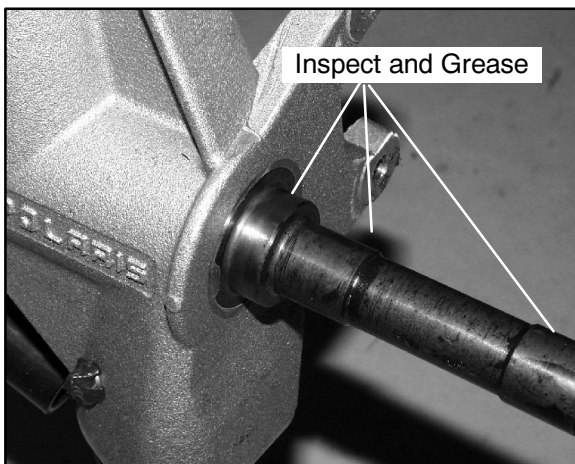

6. Install a new cotter pin. Tighten nut slightly if necessary to align cotter pin holes.
7. Rotate wheel and check for smooth operation. Bend both ends of cotter pin around end of spindle in different directions.
8. Lightly grease a new O-ring and install on hub cap. Install hub cap.
9. Rotate hub. It should rotate smoothly without binding or rough spots or side play.
10. Install brake caliper using new bolts. Tighten bolts to specified torque.

**Caliper Mounting Bolt Torque
18 ft. lbs. (25 Nm)**

2. Apply grease to spindle.
3. Install hub on spindle.
4. Apply grease to washer and install with domed side facing out.

11. Install wheel and wheel nuts and tighten evenly in a cross pattern to specified torque.

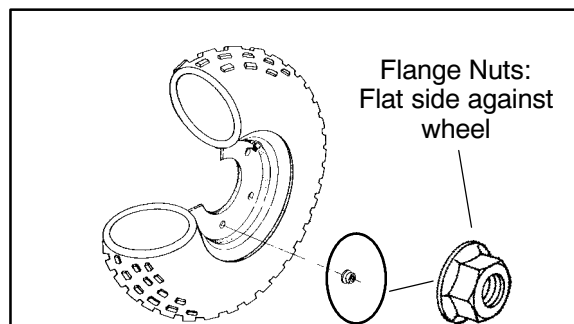
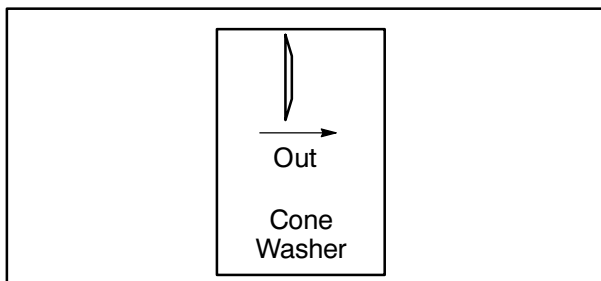

**Front Wheel Nut Torque
20 ft. lbs. (27 Nm)**



FRONT HUB EXPLODED VIEW

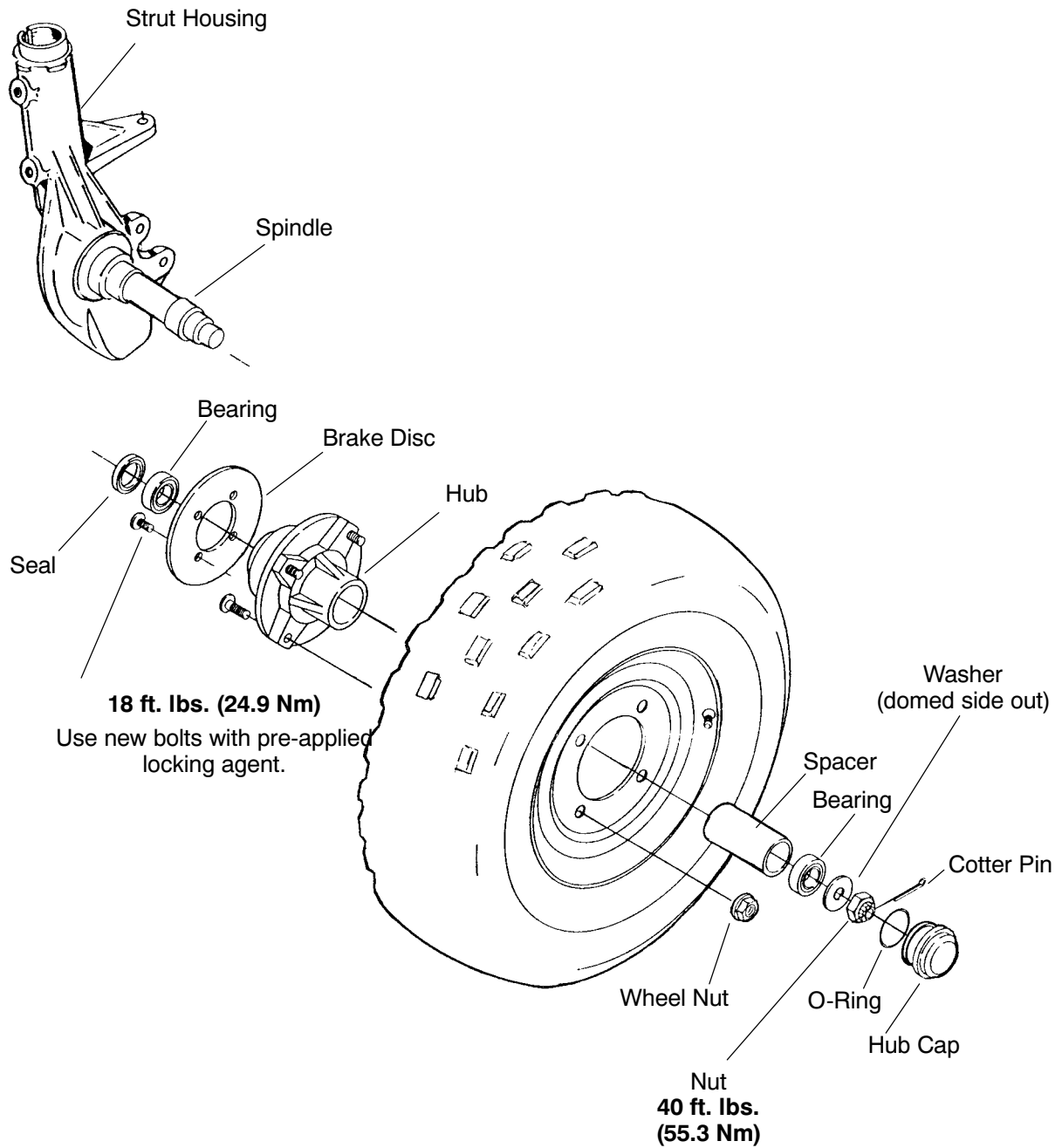

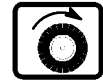

CONCENTRIC SWINGARM **REAR AXLE REMOVAL**

1. Securely support rear of machine with rear wheels off the floor. Remove rear wheels and hubs.
2. Remove drive chain.
3. Remove snap ring (A), lock sleeve (B) and foam seal (C) from axle.

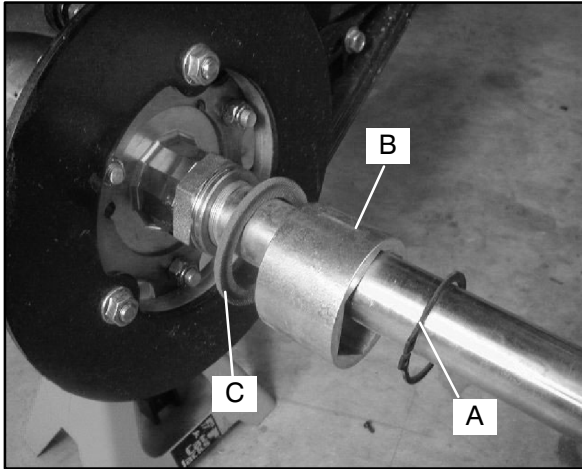

4. Remove sprocket hub nut (D).

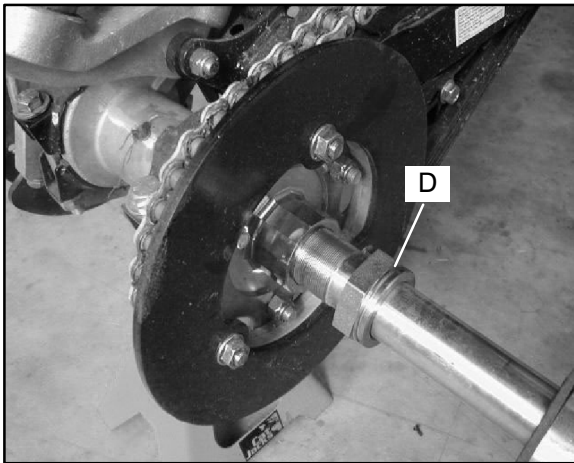

5. Remove the two rear brake caliper bolts. Remove the rear brake caliper.

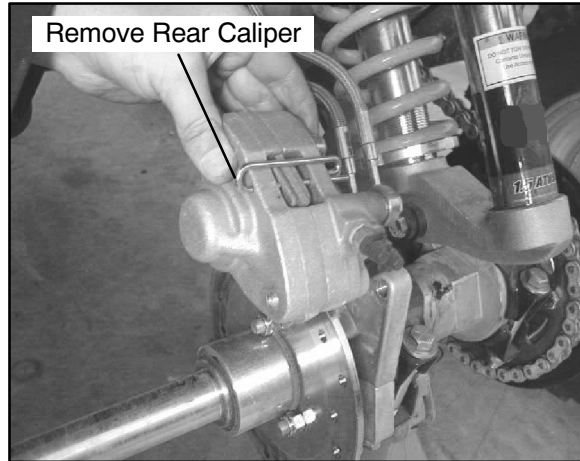

6. Support rear caliper with wire or a tie strap. Do not hang caliper by brake line.



7. Slide axle assembly out left side.

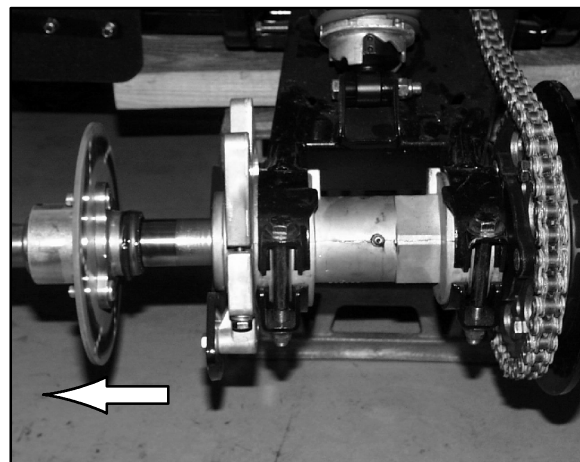



CONCENTRIC SWINGARM **REAR AXLE DISASSEMBLY**

1. Remove rear axle. (See Page 7.6)
2. Remove snap ring, collar, and foam seal.

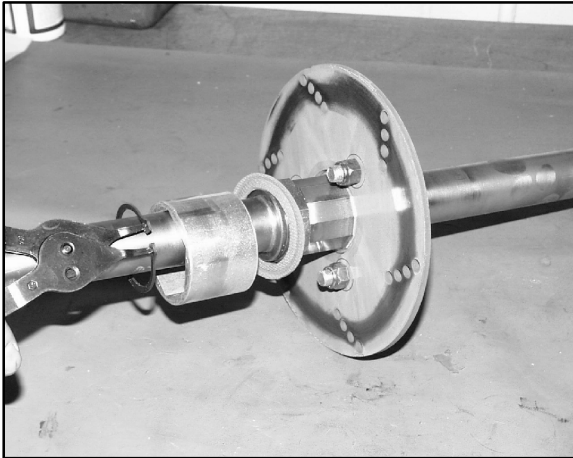

2. Install disc hub assembly on axle. Be sure hub covers stop ring. Install disc in soft jawed vise. Apply Never Seize to threads, install left axle nut and tighten to 120 ft. lbs (166 Nm). Keep tightening nut until flat aligns with flat on brake hub.

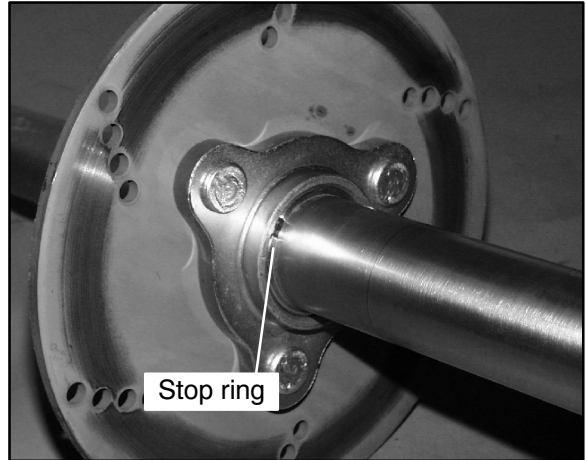

3. Remove nut, brake disc assembly, and stop ring.

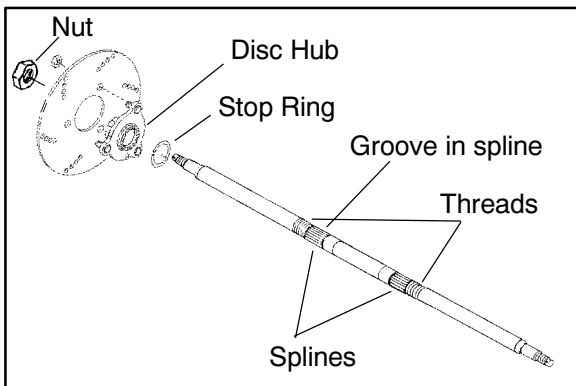

Axle Nut (Disc Side) Torque:

120 ft. lbs. (166 Nm)

3. Lubricate spacer and new O-ring. Install on axle.

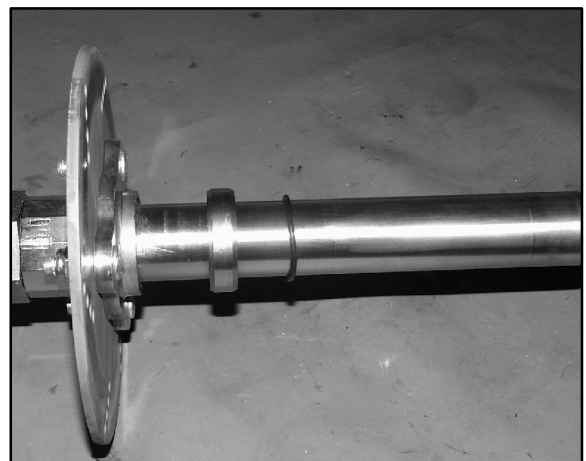

CONCENTRIC SWINGARM **REAR AXLE ASSEMBLY**

1. Install stop ring in groove on left side of axle.

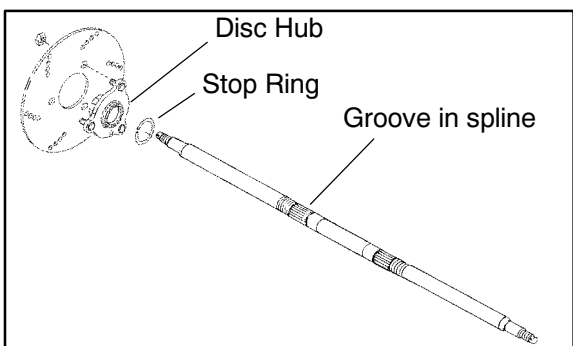

NOTE: Left side of axle is identified by the small groove in the middle of the spline.



4. Install foam seal and axle nut lock sleeve with taper toward nut. Install snap ring to retain the lock sleeve.

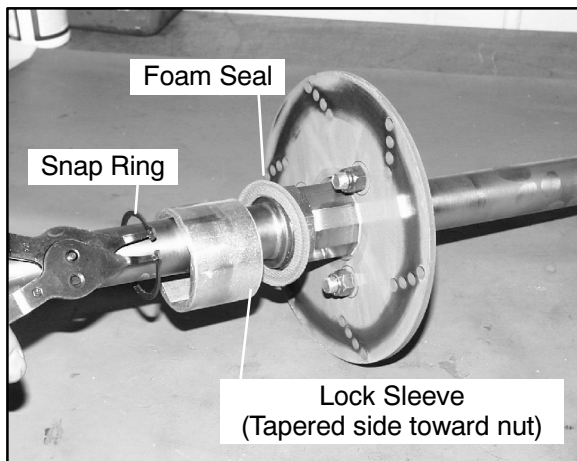

4. Install foam seal (C) and slide lock sleeve (B) onto the hub and install lock sleeve with taper inward. Install snap ring (A).

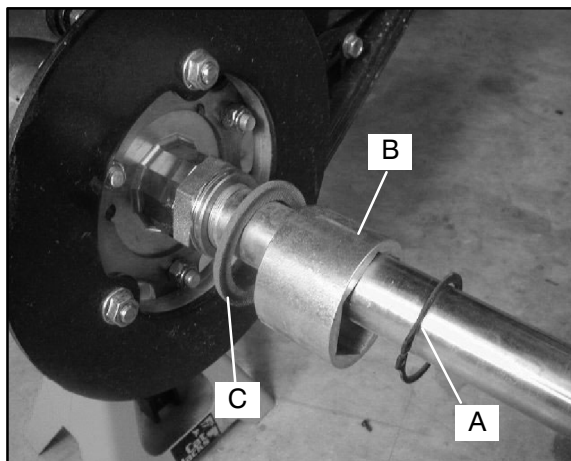

CONCENTRIC SWINGARM REAR AXLE INSTALLATION

1. Install axle from left to right.

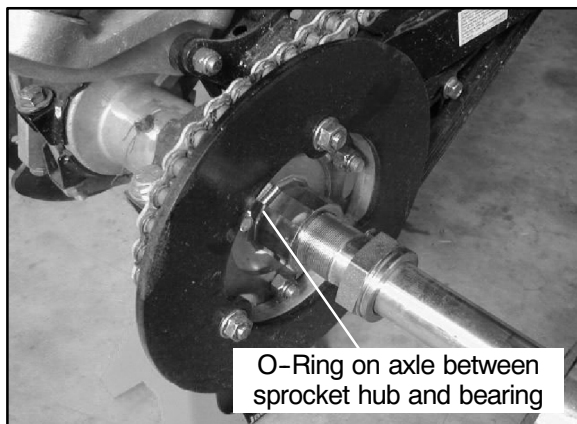

2. Lubricate and install a new O-ring on right side of axle. Slide new O-ring against RH axle bearing seal. Apply grease to sealing area on inside of sprocket hub and slide sprocket hub assembly onto the axle. Seat the hub against O-ring and bearing.
3. Apply Never Seize to threads of axle and install nut. Tighten nut with wrench to approximately 8-10 ft. lbs. (11-14 Nm). Align flat of nut with flat on hub. Axle must rotate smoothly without binding. If axle binds the nut is too tight. If axle movement (up and down or side to side) is detected, axle is too loose.

5. Install brake caliper and drive chain. Adjust drive chain (refer to Maintenance Chapter 2 for procedure). Torque eccentric pinch bolts to **30 ft. lbs. (41 Nm)** on models without a trailer hitch, or **40 ft. lbs. (55 Nm)** on models with a trailer hitch. Verify proper chain adjustment after torquing eccentric.



6. Torque brake caliper mounting bolts to 18 ft. lbs. (25 Nm).
7. Apply Never Seize to axle splines and install rear wheel hubs. Torque center hub nut to 80 ft. lbs. (109 Nm) and install a new cotter pin. Torque wheel nuts to 50 ft. lbs. (68 Nm).
8. Lubricate eccentric housing through grease fitting with Polaris Premium All Season Grease until grease is purged on each side of eccentric.

Axle Nut (Sprocket Side) Torque:

8-10 ft. lbs. (11-14 Nm)



CONCENTRIC SWINGARM REAR AXLE EXPLODED VIEW

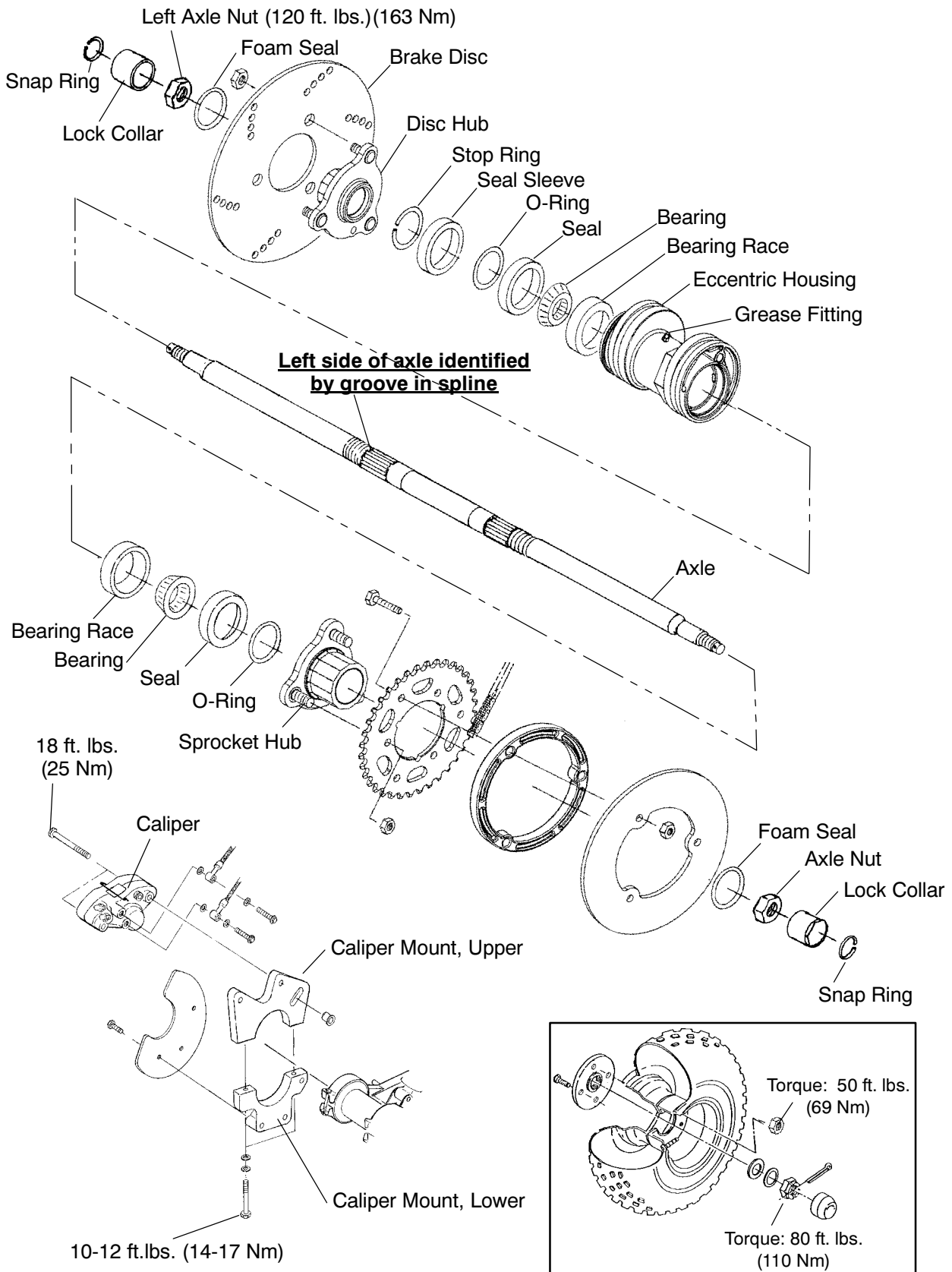

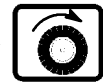

CONCENTRIC SWINGARM **REAR HOUSING REMOVAL**

1. Remove rear axle. (See Page 7.6)
2. Remove sprocket hub. Note sealing O-ring between sprocket hub and bearing.

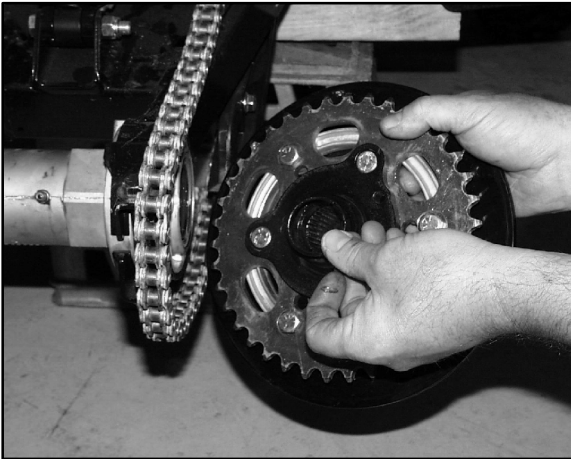

3. Remove brake caliper mounting bracket from the rear housing.

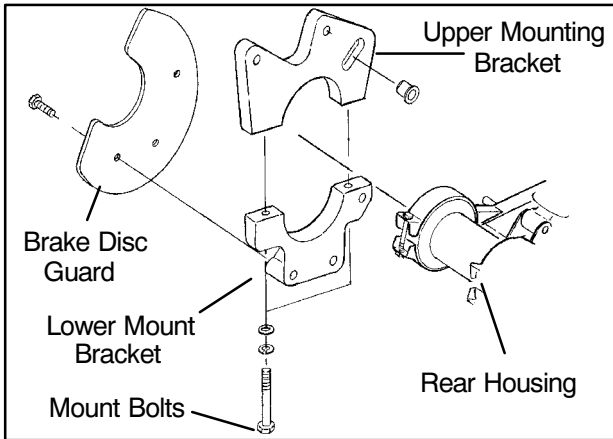

4. Remove brake caliper mount bushing from the upper mounting bracket. **NOTE:** Flange inward as shown.

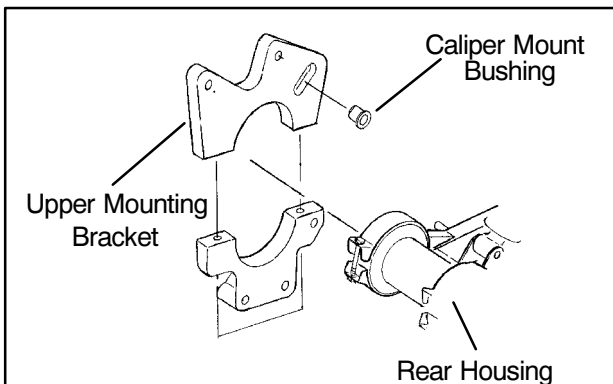

5. Remove the rear housing from the swingarm.

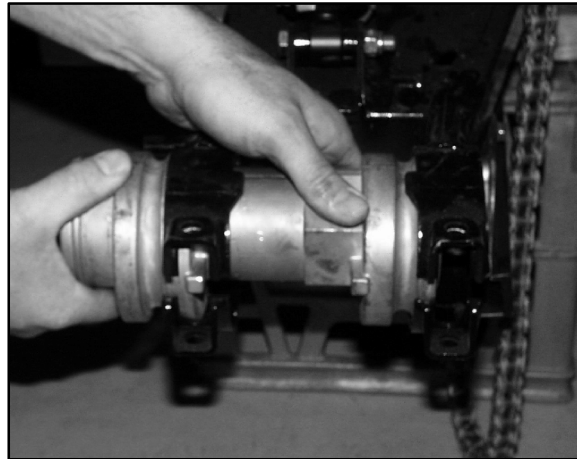

REAR HOUSING **DISASSEMBLY/BEARING** **SERVICE**

1. Remove seals from housing.

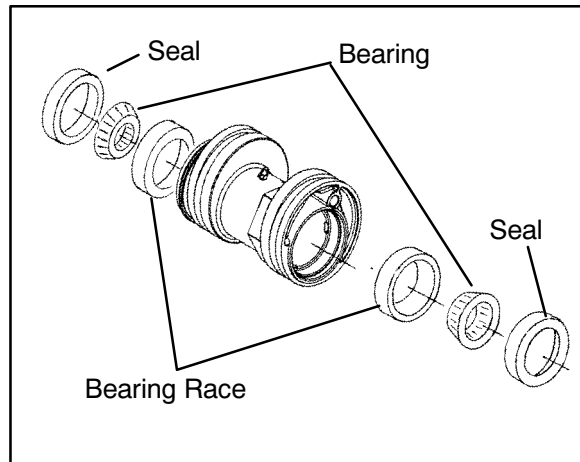

2. Remove bearings.
3. Drive bearing race out from opposite sides.
4. Inspect housing for cracks or wear. Replace if damaged.

REAR HOUSING **ASSEMBLY/BEARING** **SERVICE**

1. Drive in new bearing race with brass drift.
2. Lubricate and install new tapered bearings.
3. Lubricate and install new seals.



CONCENTRIC SWINGARM

REAR HOUSING

INSTALLATION

1. Place brake caliper pivot bushing on stud with flange inward as shown.

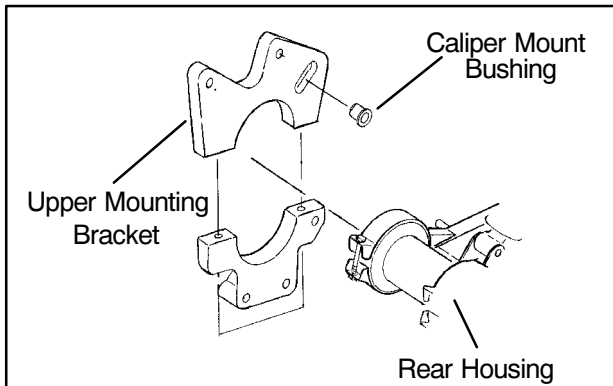

2. Loosely assemble upper and lower brake caliper mount. Do not tighten at this time.

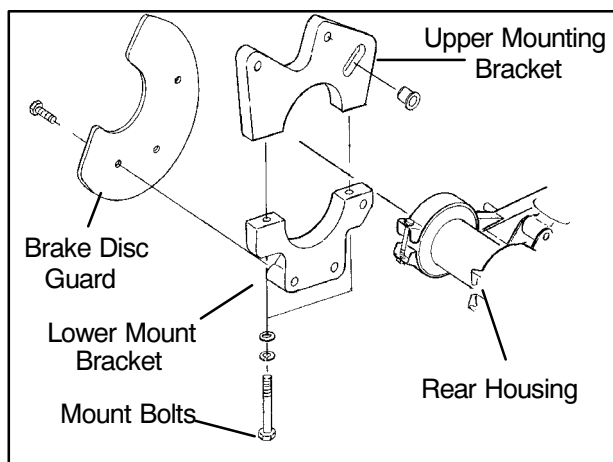

3. Install rear axle. (See Page 7.8)
4. Fill housing with grease until grease purges from both seals.



CHAPTER 8

TRANSMISSION SERVICE

Special Tools	8.2
Torque Specifications	8.2
Transmission Remove/Install	8.2
Transmission Disassembly	8.2-8.5
Transmission Assembly	8.6-8.7
Troubleshooting	8.7
Transmission Exploded View	8.7-8.8



SPECIAL TOOLS

PART NUMBER	TOOL DESCRIPTION
2871710	10" Center Distance Tool

TORQUE SPECIFICATIONS

Item	Specification
Transmission Case Bolts	12 ft. lbs. (16.6 Nm)
Bell Crank Nut	12 ft. lbs. (16.6 Nm)
Transmission Drain Plug	14 ft. lbs. (19.3 Nm)
Transmission Mounting Bolts	25 ft. lbs. (34.5 Nm)
Swing Arm Pivot Bolts (Concentric Swingarm)	150 ft. lbs. (207.5 Nm)

LUBRICATION

Refer to maintenance section for transmission lubricant type and capacity.

TRANSMISSION REMOVAL

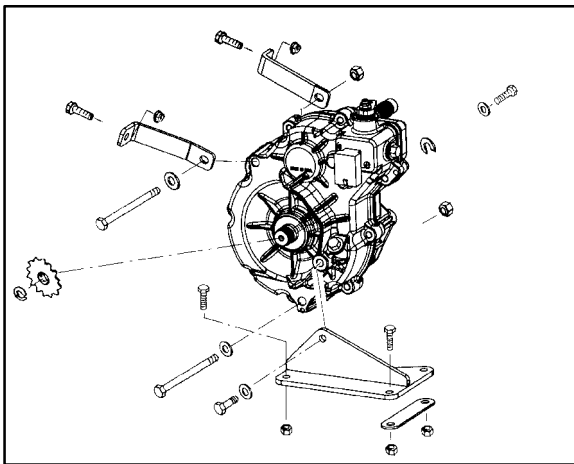

1. Remove seat, cab and air box.
2. Remove right side heat and reservoir bracket.
3. Remove PVT outer cover, both drive and driven clutch, and inner PVT cover (refer to Clutch Chapter 6).
4. Remove rear PVT bracket.
5. Remove carburetor.

6. Disconnect harness from gear position switch.
7. Remove drive chain and sprocket.
8. Remove mounting bolts and brackets as shown.
9. Remove through-bolt from bottom of transmission.
10. Remove transmission from right side of frame.

TRANSMISSION INSTALLATION

1. Reverse removal steps to install transmission.

NOTE: Install the Center Distance Tool (PN 2871710) on engine and transmission input shaft before tightening transmission mounting bolts. Align clutches as outlined in Clutch Chapter 6.

TRANSMISSION DISASSEMBLY

1. Remove gear position switch.

CAUTION:

If switch is not removed prior to disassembly, switch damage will result.

2. Place bellcrank in neutral position.
3. Remove sprocket retaining clip and sprocket.
4. Remove the transmission cover bolts.
5. With a soft face hammer tap on the (3) cover bosses and carefully remove the cover.

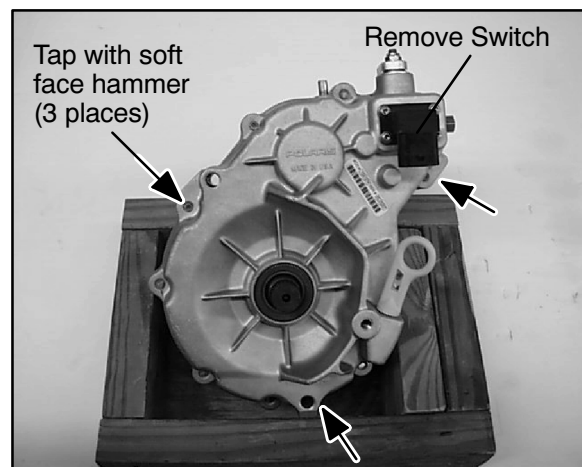

6. Remove detent plug, washer, spring and shifting bullet.

NOTE: Shifting bullet has a radiused end making it directional.

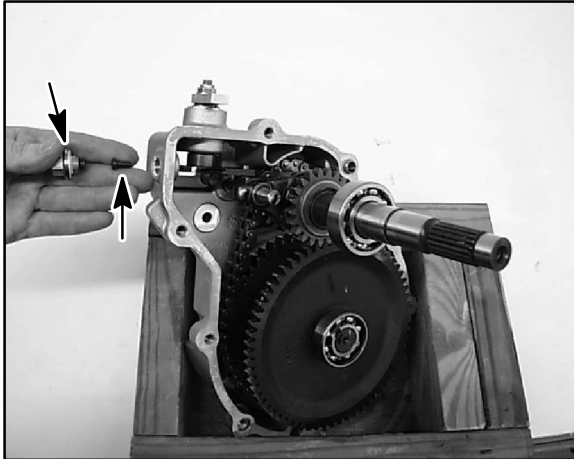

7. Using a wrench on the nut of the bellcrank, turn in a clockwise direction to assist with removal of shift assembly and drive gear.

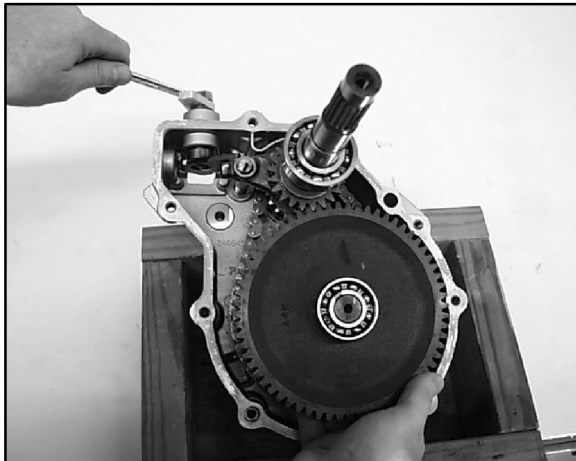

8. Remove shift assembly and gear as an assembly.

NOTE: Direction of shift fork.

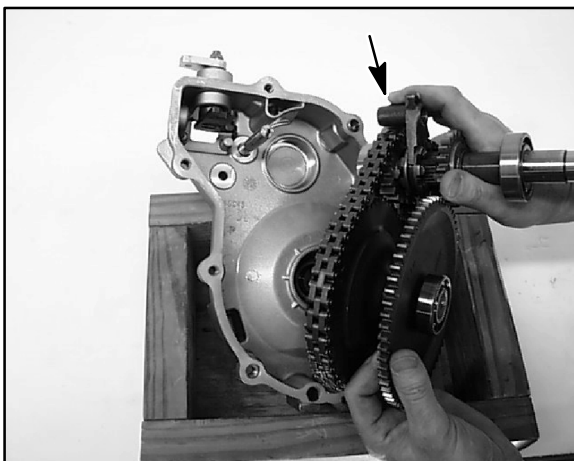

9. Inspect shift fork surface for wear or damage. Replace if necessary.

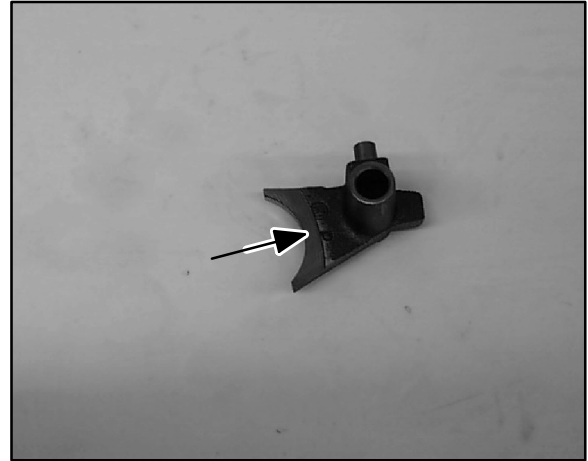

10. Remove shift fork guide pin.

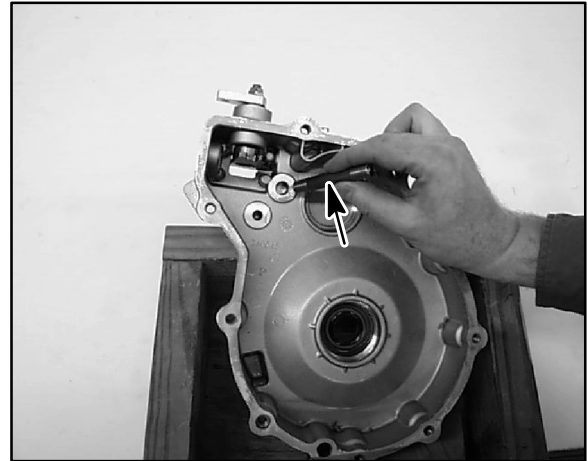

11. Mark orientation of bellcrank to the shift fork shaft.



12. Remove bellcrank. Use a small puller if necessary.

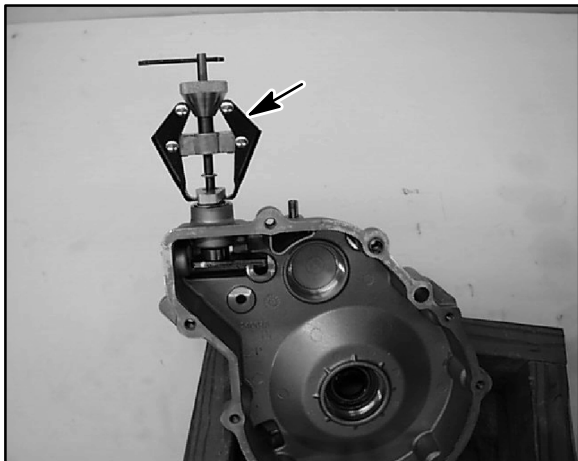

13. Remove snap ring and washer. Pull down and rotate shift fork shaft back and forth to remove.

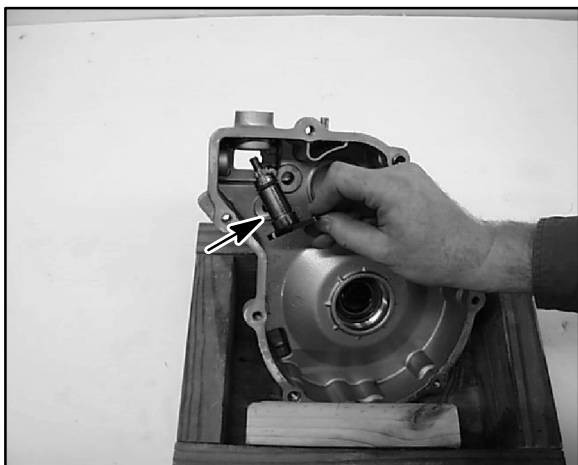

14. Inspect shift fork shaft O-ring. Replace if necessary. Lubricate O-ring to ease in reassembly and to protect O-ring during assembly.



15. Remove input shaft bearing.

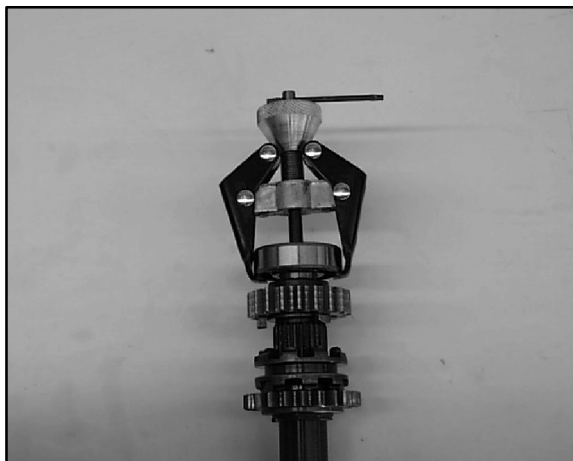

16. Inspect gears for galling and wear on teeth and bearing surface. Replace if necessary.

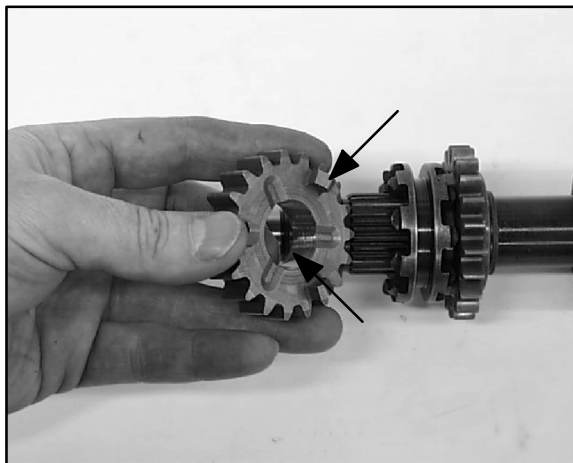

17. Remove bearing from other end of input shaft. Remove two snap rings and gear.





18. Inspect gear bushing. Replace if half of teflon surface is gone.

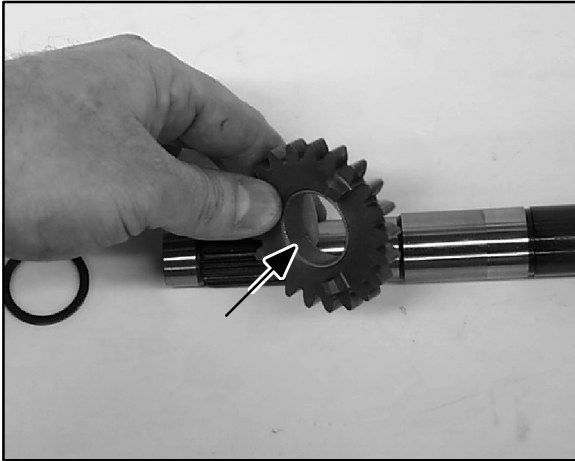

19. Inspect output shaft gear, sprocket and bearing. Replace if necessary.

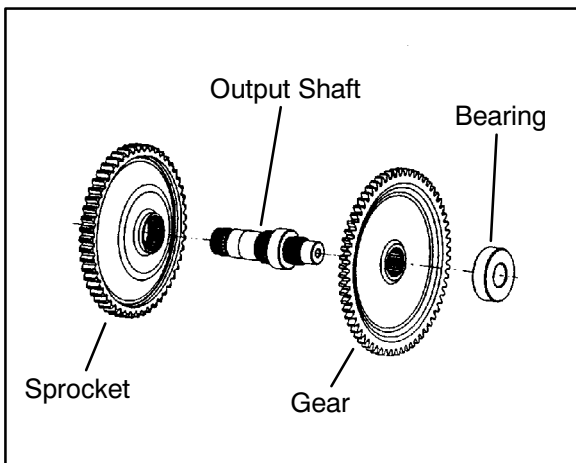

20. Stretch chain tight on a flat surface and measure the length of 8 pitches in a minimum of three places on chain. Replace chain if measurement is longer than 3.0904".

Chain Stretch Limit

8 pitch length = 3.0904" Maximum

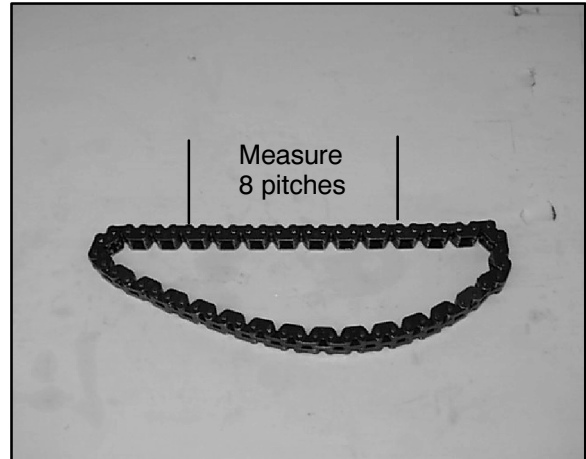

TRANSMISSION ASSEMBLY

1. Assemble input shaft assembly.

NOTE: Install bearings with numbers and letters facing out so they can be read after assembly. Sprocket cogs face the dog gear.

NOTE: Input gear cogs face inward on input shaft.

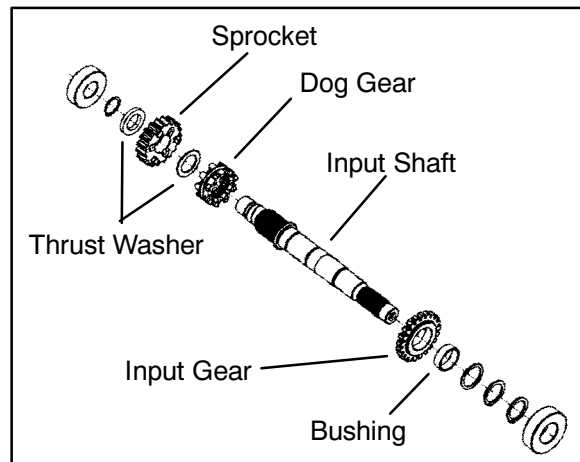

2. Assemble output shaft with sprocket, gear and bearing if they were disassembled.
3. Assemble output shaft assembly with chain to the input shaft assembly.
4. Install shift shaft, driven sprocket and gear into the case.



5. Install shift fork.

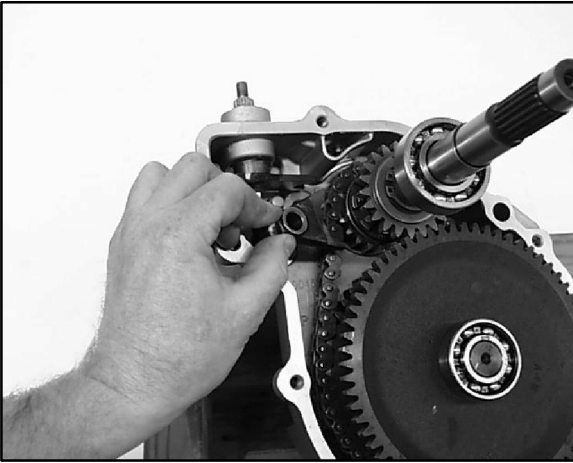

6. Insert fork guide pin.

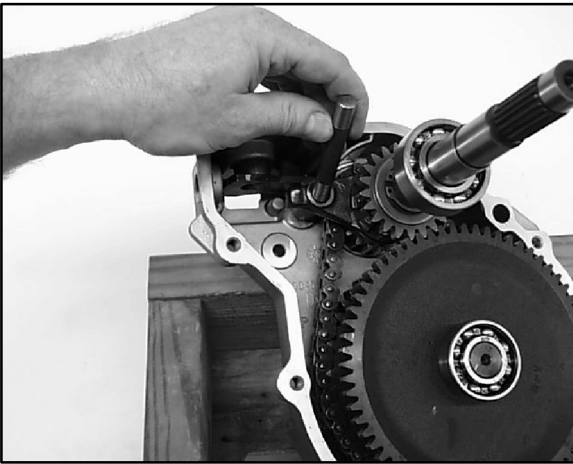

7. Prior to reinstalling the cover make sure the mating cover surfaces are clean and dry. Apply Crankcase Sealant (PN 2871557) to mating surfaces.



8. Reinstall cover and torque bolts in a criss-cross pattern in 3 steps to 18 ft. lbs. (25 Nm).

9. Install drain plug with a new sealing washer. Torque drain plug to 14 ft. lbs. (19 Nm).

10. Insert shifting bullet with tip in position as shown. Insert spring and plug. Torque plug to 14 ft. lbs. (19 Nm).

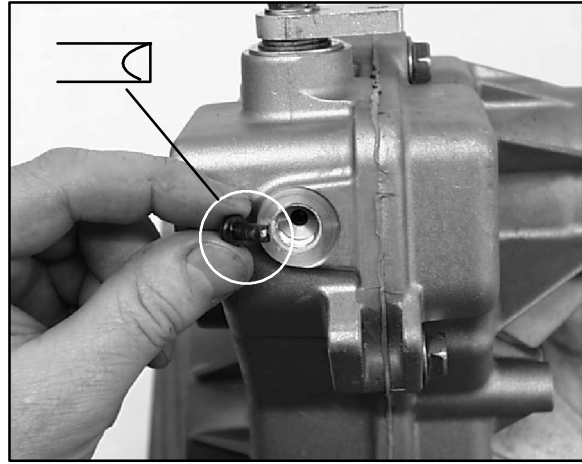

11. Install transmission and add Polaris Premium Synthetic Gear Case Lubricant (PN 2871477) in the recommended amount. Refer to Maintenance Chapter 2.

12. Install gear indicator switch. Apply Loctite™ 242 (PN 2871949) to threads of switch screws and torque to 13-16 in. lbs. (1.5-1.9 Nm).





TROUBLESHOOTING CHECKLIST

Check the following items when shifting difficulty is encountered.

- Idle speed adjustment
- Transmission oil type/quality
- Transmission torque stop adjustment
- Drive belt deflection
- Loose fasteners on rod ends
- Loose fasteners on shifter
- Worn rod ends, clevis pins, or pivot arm bushings

- Linkage rod adjustment and rod end positioning
- *Worn, broken or damaged internal transmission components

***NOTE:** To determine if shifting difficulty or problem is caused by an internal transmission problem, isolate the transmission by disconnecting linkage rods from transmission bellcranks. Manually select each gear range at the transmission bellcrank, and test ride vehicle. If it functions properly, the problem is outside the transmission.

If transmission problem remains, disassemble transmission and inspect all gear dogs for wear (rounding), damage. Inspect all bearings for wear.

TRANSMISSION EXPLODED VIEW

NOTE: See next page for exploded view of transmission.

Ref.	Qty	Description	Ref.	Qty	Description
	1	Asm., Gearcase	24.	1	Washer
1.	2	Bearing	25.	1	Plug, Detent, Extension
2.	1	Ring, Retaining	26.	1	Dipstick
3.	1	Washer, Thrust	27.	2	Seal
4.	1	Sprocket, 19T	28.	1	Tube, Vent
5.	1	Washer, Thrust	29.	1	Gearcase, RH
6.	1	Dog, Engagement, High/Reverse	30.	2	Pipe, Knock
7.	1	Shaft, Input	31.	1	Shaft, Shift
8.	1	Gear, 21T	32.	2	Fork, Shift
9.	1	Bushing	33.	1	Gearcase, LH
10.	1	Washer	34.	1	Decal, Switch
11.	2	Snap Ring	35.	9	Screw
12.	2	Bearing	36.	1	Screw
13.	1	Nut, FLEXLOC	37.	1	Nut
14.	1	Washer	38.	1	Plug, Torque Stop
15.	1	Bellcrank, HLR	39.	1	Bushing, Pivot
16.	1	Ring, Retaining	40.	1	Washer
17.	1	Washer	41.	1	Chain, Silent, 60P, 11W
18.	1	O-Ring	42.	1	Sprocket, 51T
19.	1	Shaft, Shift	43.	1	Shaft, Output
20.	1	Switch	44.	1	Gear, 64T
21.	4	Screw			
22.	1	Bullet, Shifting			
23.	1	Spring, Compression			



TRANSMISSION EXPLODED VIEW

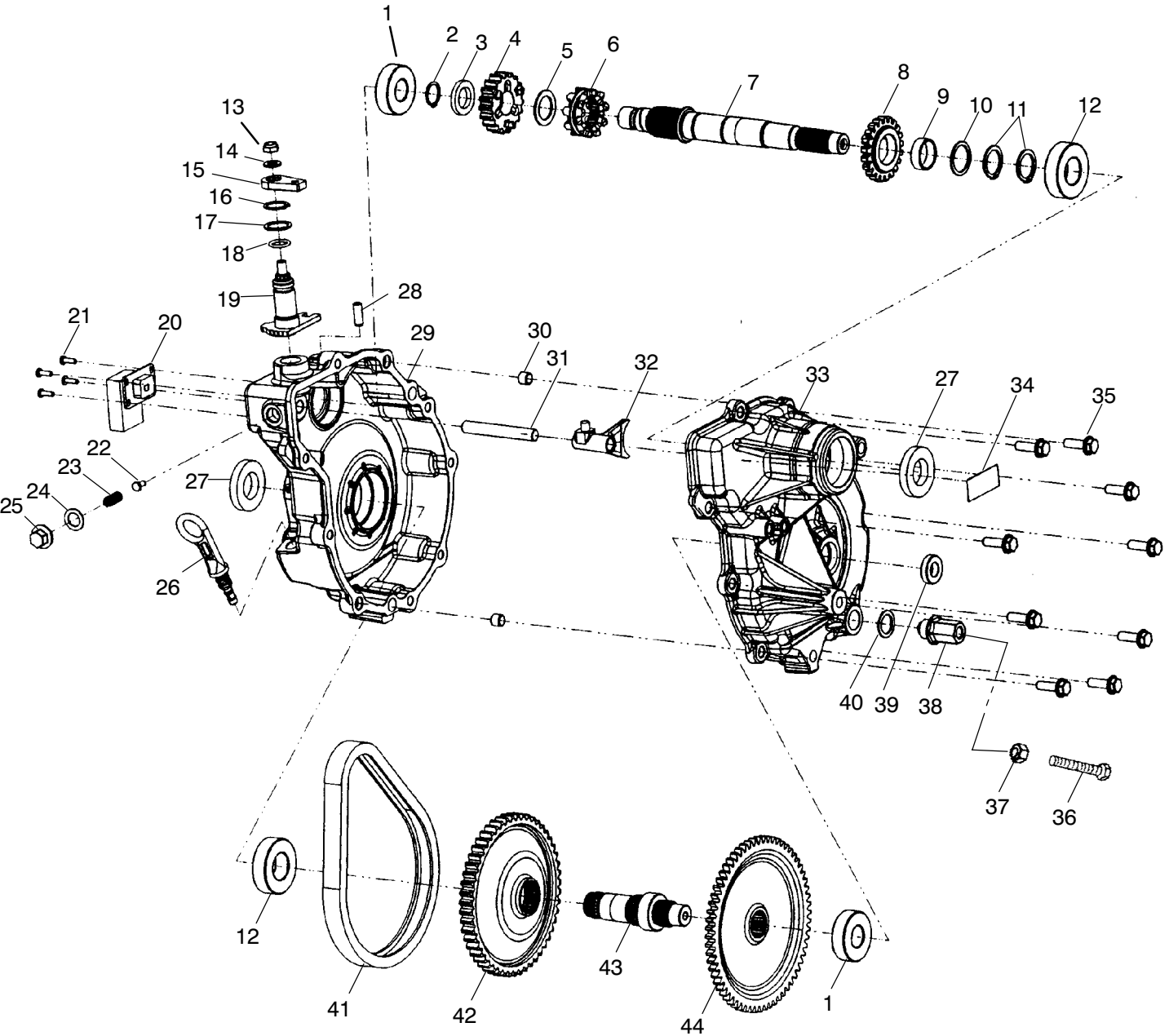



CHAPTER 9 **BRAKES**

Specifications/Torques	9.2
Special Tools	9.3
Brake System Service Notes	9.3
Brake Noise Troubleshooting	9.3
Hydraulic Brake System Operation ...	9.4
Brake System Main Components	9.5
Dual Hydraulic Caliper Bleeding	9.5
Fluid Replacement/Bleeding Procedure	9.6-9.7
Master Cylinder Disassembly	9.7
Master Cylinder Installation	9.8
Front Pad Removal	9.9-9.10
Front Pad Assembly	9.10-9.11
Front Disc Inspection	9.11
Front Disc Removal/Replacement	9.11-9.12
Front Caliper Removal	9.12
Front Caliper Disassembly	9.12-9.13
Front Caliper Inspection	9.13-9.14
Front Caliper Assembly	9.14
Front Caliper Installation	9.15
Front Caliper Exploded View	9.16
Rear Pad Removal	9.17
Rear Pad Installation	9.17-9.18
Rear Caliper Removal/Inspection	9.18-9.19
Rear Caliper Assembly	9.19-9.20
Rear Disc Inspection	9.20
Troubleshooting	9.21
Rear Caliper Exploded View	9.22

**SPECIFICATIONS**

Front Brake Caliper		
Item	Standard	Service Limit
Brake Pad Thickness	.298 ± .0073" / 7.56 ± .185 mm	.150" / 3.81 mm
Brake Disc Thickness	.150-.165" / 3.810-4.191 mm	.140" / 3.556 mm
Brake Disc Thickness Variance Between Measurements	-	.002" / .051 mm
Brake Disc Runout	-	.020" / .50 mm

Rear Brake Caliper		
Item	Standard	Service Limit
Brake Pad Thickness	.270 ± .005" / 6.85 ± .127 mm	.150" / 3.81 mm
Brake Disc Thickness	.177-.188" / 4.49-4.77 mm	.167" / 4.242 mm
Brake Disc Thickness Variance Between Measurements	-	.002" / .051 mm
Brake Disc Runout	-	.010" / .25 mm

Master Cylinder I.D.	.750"
----------------------	-------

TORQUE SPECIFICATIONS

Item	Torque (ft. lbs. except where noted*)	Torque (Nm)
Front Caliper Mounting Bolts	18.0	25
Rear Caliper Mounting Bolts	28	38
Master Cylinder Mounting Bolts	*25 in. lbs.	3.0
Master Cylinder Reservoir Cover Bolt	*5 in. lbs.	.56
Brake Line Banjo Bolt	15.0	21
Front Brake Disc	18.0	25
Front Wheel Mounting Nuts	20.0	28

NOTE: Refer to the tightening procedures in this chapter when torquing the bolts. Some special procedures are used when torquing certain bolts and fasteners.



SPECIAL TOOLS

PART NUMBER	TOOL DESCRIPTION
2870975	Mity Vac™ Pressure Test Tool

BRAKE SYSTEM SERVICE

NOTES

Disc brake systems are light weight, low maintenance, and perform well in the conditions ATVs routinely encounter. There are a few things to remember when replacing disc brake pads or performing brake system service to ensure proper system function and maximum pad service life.

- Optional pads are available to suit conditions in your area. Select a pad to fit riding style and environment.
- Do not over-fill the master cylinder fluid reservoirs.
- Make sure the brake levers return freely and completely.
- Adjust stop pin on front caliper after pad service.
- Check and adjust master cylinder reservoir fluid levels after pad service.
- Make sure atmospheric vent on reservoirs are unobstructed.

- Test for brake drag after any brake system service and investigate cause if brake drag is evident.
- Make sure caliper moves freely on guide pins.
- Inspect caliper piston seals for foreign material that could prevent caliper pistons from returning freely.
- Perform a brake burnishing procedure after installing new pads to maximize service life.

BRAKE NOISE TROUBLESHOOTING

NOTE: 2003 Model Trailblazer ATVs are equipped with anti-squeek brake pads, but in some extreme cases brake noise may occur.

Dirt or dust buildup on the brake pads and disc is the most common cause of brake noise (squeal caused by vibration). If cleaning does not reduce the occurrence of brake noise, Permatex™ Disc Brake Quiet (**PN 2872113**) can be applied to the back of the pads. Follow directions on the package. This will keep pads in contact with caliper piston(s) to reduce the chance of squeaks caused by dirt or dust. See table below.

Brake Noise Troubleshooting	
Possible Cause	Remedy
Dirt, dust, or imbedded material on pads or disc	Spray disc and pads with a non-flammable aerosol brake cleaner. Remove pads and/or disc hub to clean imbedded material from disc or pads.
<u>Pad(s) dragging on disc (noise or premature pad wear)</u> Improper adjustment Insufficient lever or pedal clearance Master cylinder reservoir overfilled Master cylinder compensating port restricted Master cylinder piston not returning completely Caliper piston(s) not returning Operator error (riding the brake / park brake applied)	Adjust pad stop (front calipers) Check position of controls & switches. Set to proper level Clean compensating port Inspect. Repair as necessary Clean piston(s) seal Educate operator
Loose wheel hub or bearings	Check wheel and hub for abnormal movement.
Brake disc warped or excessively worn	Replace disc
Brake disc misaligned or loose	Inspect and repair as necessary
Noise is from other source (chain, axle, hub, disc or wheel)	If noise does not change when brake is applied check other sources. Inspect and repair as necessary
Wrong pad for conditions	Change to a softer or harder pad



HYDRAULIC BRAKE SYSTEM OPERATION

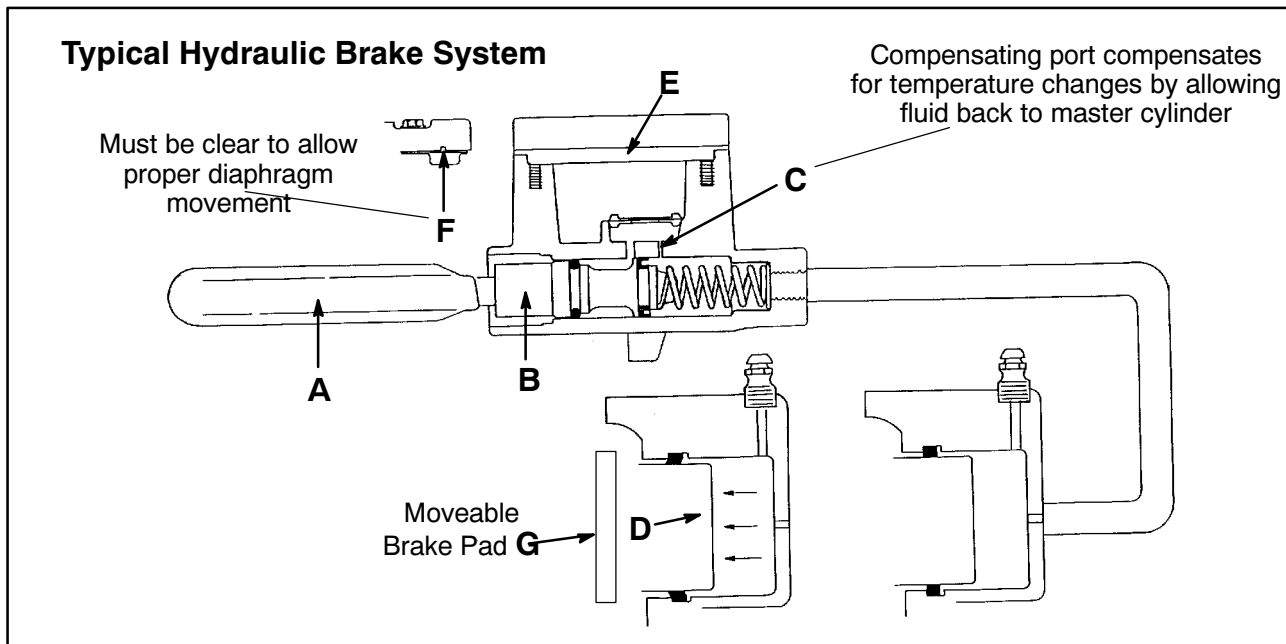

The Polaris brake system consists of the following components or assemblies: brake lever; master cylinder; hydraulic hose; brake calipers (slave cylinder); brake pads; and brake discs, which are secured to the drive line.

When the hand activated brake lever (A) is applied it contacts a piston (B) within the master cylinder. As the master cylinder piston moves inward it closes a small opening (compensating port) (C) within the cylinder and starts to build pressure within the brake system. As the pressure within the system is increased, the piston (D) located in the brake caliper moves outward and applies pressure to the moveable brake pad. This pad contacts the brake disc and moves the caliper in its floating bracket, pulling the stationary side pad into the brake disc. The resulting friction reduces brake disc and vehicle speed. As the lever pressure is increased, the braking affect is also increased.

The friction applied to the brake pads will cause the pads to wear. As these pads wear, the piston within the caliper moves further outward and becomes self adjusting. Fluid from the reservoir fills the additional area created when the caliper piston moves outward.

Brake fluid level is critical to proper system operation. Too little fluid will allow air to enter the system and cause the brakes to feel spongy. Too much fluid could cause brakes to drag due to fluid expansion.

Located within the master cylinder is the compensating port (C) which is opened and closed by the master cylinder piston assembly. The port is open when the lever is released and the master cylinder piston is outward. As the temperature within the hydraulic system changes, this port compensates for fluid expansion (heated fluid) or contraction (cooled fluid). During system service, be sure this port is open. Due to the high temperatures created within the system during heavy braking, it is very important that the master cylinder reservoir have adequate space to allow for fluid expansion. **Never overfill the reservoir!** Fill to 1/4" - 5/16" (.64 - .80 cm) from top of the cylinder.

This system also incorporates a diaphragm (E) as part of the cover gasket; and a vent port (F) located between the gasket and the cover. The combination diaphragm and vent allow for the air above the fluid to equalize pressure as the fluid expands or contracts. Make sure the vent is open and allowed to function. If the reservoir is over filled or the diaphragm vent is plugged the expanding fluid may build pressure in the brake system leading to brake failure.

When servicing Polaris ATV brake systems use only Polaris DOT 3 High Temperature Brake Fluid (PN 2870990). Polaris brake fluid is sold in 5.5 oz. bottles. **WARNING:** Once a bottle is opened, use what is necessary and discard the rest in accordance with local laws. Do not store or use a partial bottle of brake fluid. Brake fluid is hygroscopic, meaning it rapidly absorbs moisture. This causes the boiling temperature of the brake fluid to drop, which can lead to early brake fade and the possibility of serious injury.



BRAKE SYSTEM MAIN COMPONENTS

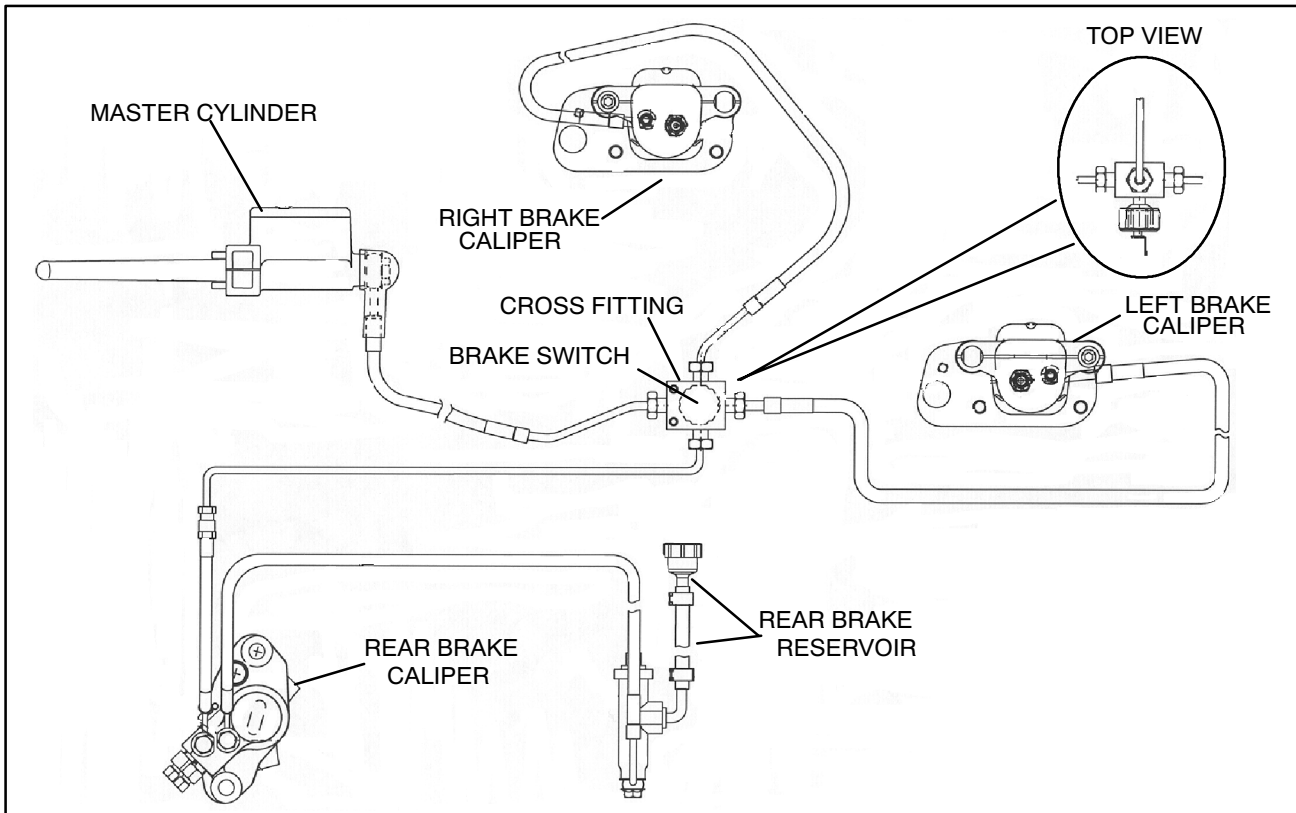

DUAL HYDRAULIC CALIPER BLEEDING

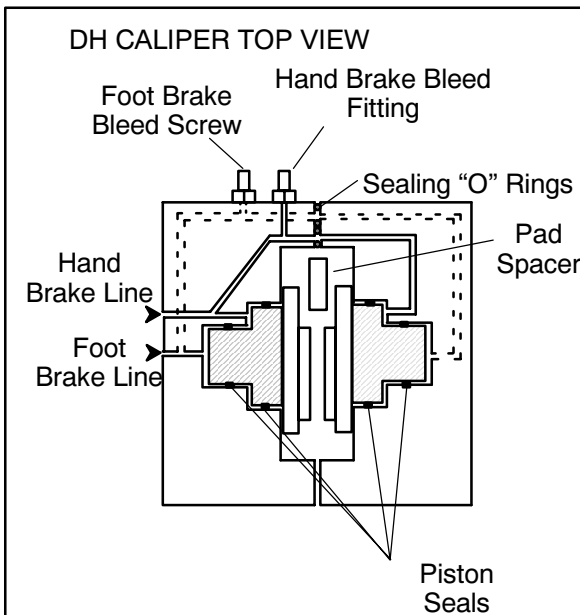

caliper piston, but remain separated by seals. The left hand brake system applies hydraulic pressure to both front calipers and only the *outer* diameter of the rear caliper piston. The right hand brake applies pressure to the inner portion of the rear caliper piston. Because the left and right hand brake hydraulic systems are separate, there are also two bleed screws - one for the outer fluid chamber (left hand brake), and one for the inner fluid chamber (right hand brake). The basic procedure for bleeding the brake system is the same as outlined on Page 9.6 - 9.7; however, each system must be bled separately.

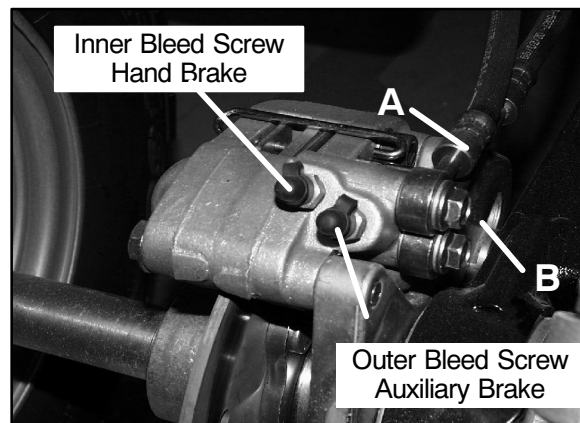

This caliper is a stepped piston design, with two independent hydraulic systems contained in the same caliper body. The caliper piston is T-shaped, which allows both left and right hand brake to use the same



- The upper most (inner) bleed screw and brake line (A) is for the left hand brake system.
- The lower (outer) bleed screw and brake line (B) is for the auxiliary brake system.

FLUID REPLACEMENT/BLEEDING PROCEDURE

NOTE: When bleeding the brakes or replacing the fluid always start with the caliper farthest from the master cylinder.

CAUTION:

Always wear safety glasses.

CAUTION:

Brake fluid will damage finished surfaces. Do not allow brake fluid to come in contact with finished surfaces.

BRAKE BLEEDING - FLUID CHANGE

NOTE: This procedure should be used to change fluid or bleed brakes during regular maintenance.

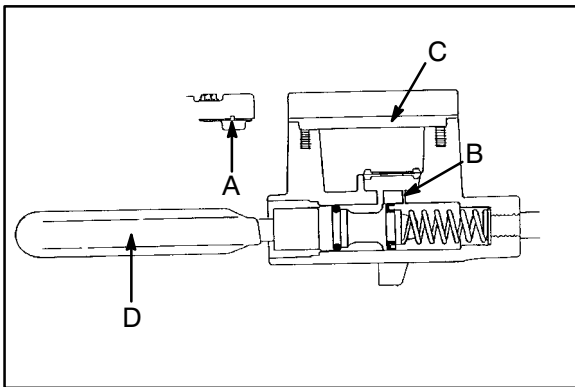

1. Clean reservoir cover thoroughly.
2. Remove screws, cover, and diaphragm (C) from reservoir.
3. Inspect vent slots (A) in cover and remove any debris or blockage.
4. If changing fluid, remove old fluid from reservoir with a Mity Vac™ (PN 2870975) or similar tool.

NOTE: Do not remove brake lever when reservoir fluid level is low.

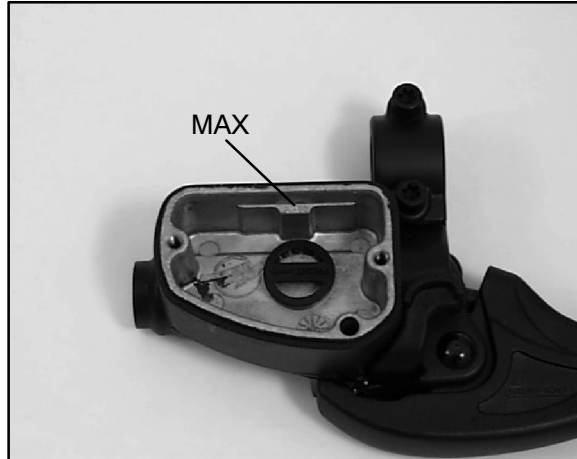

5. Add brake fluid to the upper level mark on reservoir.

Polaris DOT 3 Brake Fluid
(PN 2870990)

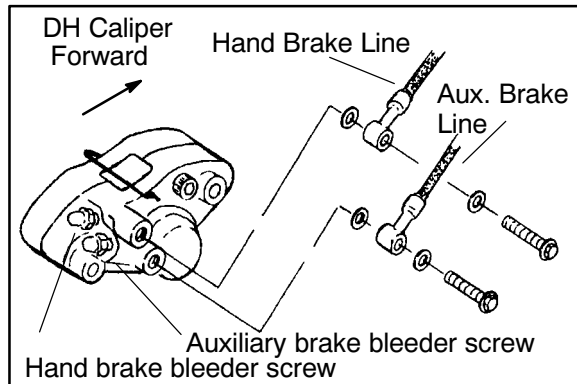

6. Begin bleeding procedure with the caliper that is farthest from the master cylinder. Install a box end wrench on caliper bleeder screw. Attach a clean, clear hose to fitting and place the other end in a clean container. Be sure the hose fits tightly on fitting.

NOTE: Fluid may be forced from compensation port (B) when brake lever is pumped. Place diaphragm (C) in reservoir to prevent spills. Do not install cover. Refer to Illustration on page 9.4.

7. *Slowly* pump brake lever (D) until pressure builds and holds.
8. While maintaining lever pressure, open bleeder screw. Close bleeder screw and release brake lever. **NOTE:** Do not release lever before bleeder screw is tight or air may be drawn into caliper.



- Repeat procedure until clean fluid appears in bleeder hose and all air has been purged. Add fluid as necessary to maintain level in reservoir.

CAUTION:

Maintain at least 1/2" (1.27 cm) of brake fluid in the reservoir to prevent air from entering the master cylinder.

- Tighten bleeder screw securely and remove bleeder hose.
- Repeat procedure Steps 5-9 for the remaining caliper(s).



- Add brake fluid to the proper level.

Master Cylinder Fluid Level:

MAX level inside reservoir

Sight glass must look dark, if sight glass is clear, fluid level is too low



- Install diaphragm, cover, and screws. Torque the screws to 5 in.lbs. (0.56 Nm).

Reservoir Cover Torque -

5 in. lbs. (0.56 Nm)

- Field test machine at low speed before putting into service. Check for proper braking action and lever reserve. With lever firmly applied, lever reserve should be no less than 1/2" (1.3 cm) from handlebar.
- Check brake system for fluid leaks and inspect all hoses and lines for wear or abrasion. Replace hose if wear or abrasion is found.

MASTER CYLINDER DISASSEMBLY

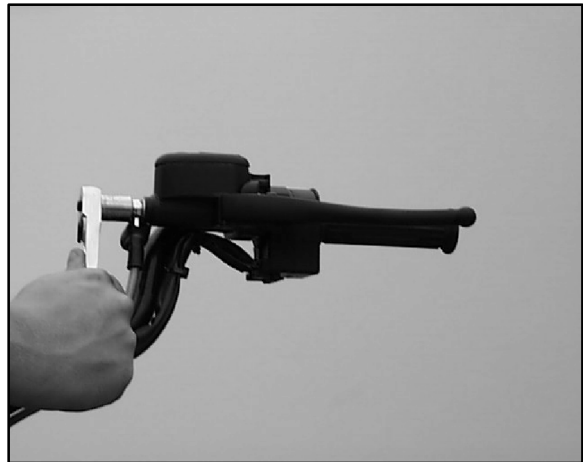

- Clean master cylinder and reservoir assembly. Make sure you have a clean work area to disassemble brake components.
- Place a shop towel under brake line connection at master cylinder. Loosen banjo bolt; remove bolt and sealing washers.

CAUTION:

Brake fluid will damage finished surfaces. Do not allow brake fluid to come in contact with finished surfaces.



3. Remove master cylinder from handlebars.

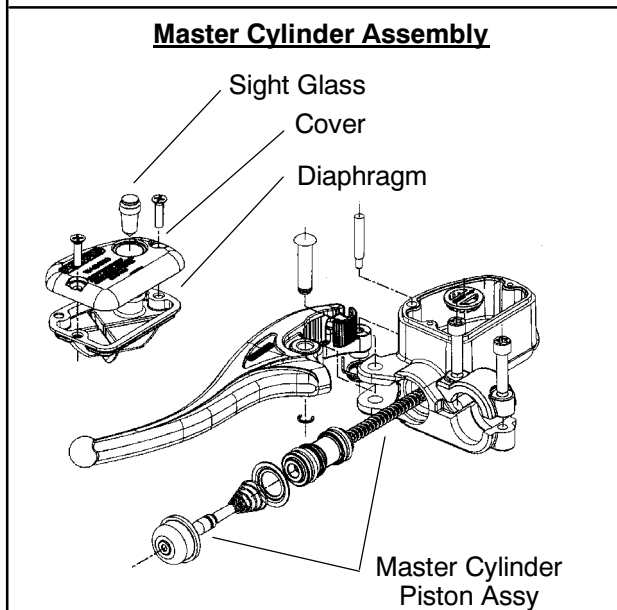
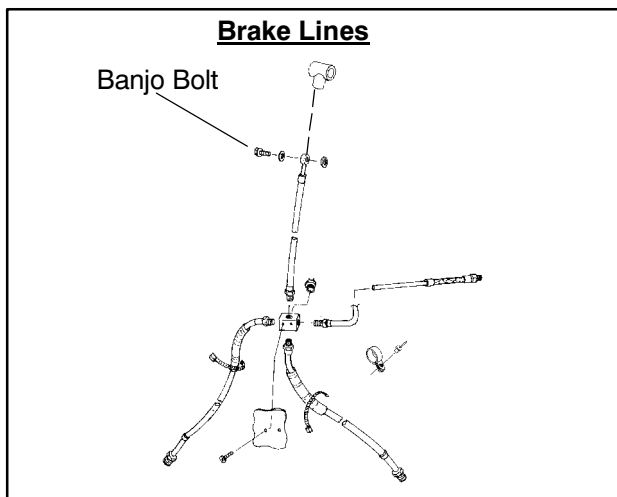

1. Install master cylinder on handlebars. Torque mounting bolts to 25 in. lbs. (3 Nm). Torque the inside bolt first as indicated in the illustration.

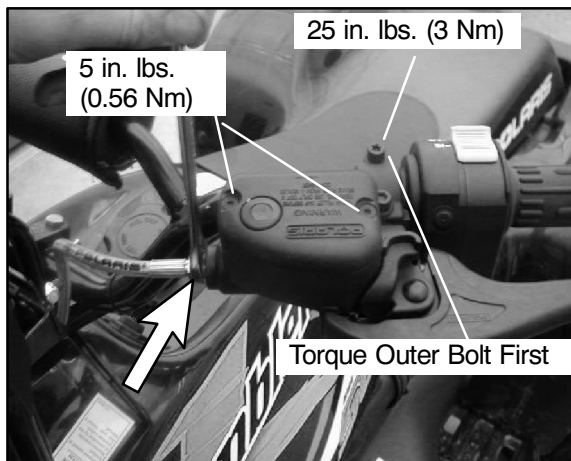

NOTE: To speed up the brake bleeding procedure the master cylinder can be purged of air before brake line is attached. Fill with DOT3 Brake Fluid (PN 2870990) and pump lever slowly two to three times with finger over the outlet end to purge master cylinder of air.

2. Place new sealing washers on each side of banjo line.

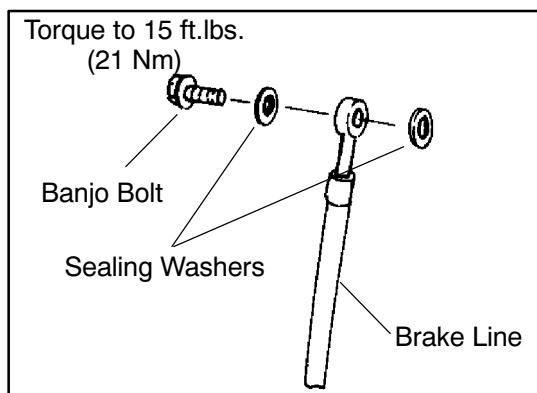

**Master Cylinder Mounting Bolt
Torque 25 in. lbs. (3 Nm)**

**Brake Line Banjo Bolt Torque
15 ft. lbs. (21 Nm)**

MASTER CYLINDER INSTALLATION

Master cylinders are not rebuildable. The complete master cylinder must be replaced. When replacing the brake master cylinder assembly, use the correct assembly. There are different brake master cylinders for the different Polaris ATV models. Refer to your parts manual or guide for the correct parts.

3. Install brake line on master cylinder *hand tight*.
4. Fill reservoir with DOT3 Brake Fluid (PN 2870990).



**Polaris DOT 3 Brake Fluid
(PN 2870990)**

5. Follow bleeding procedure on Pages 9.6-9.7. Check all connections for leaks and repair if necessary.

FRONT PAD REMOVAL

1. Elevate and support front of machine.

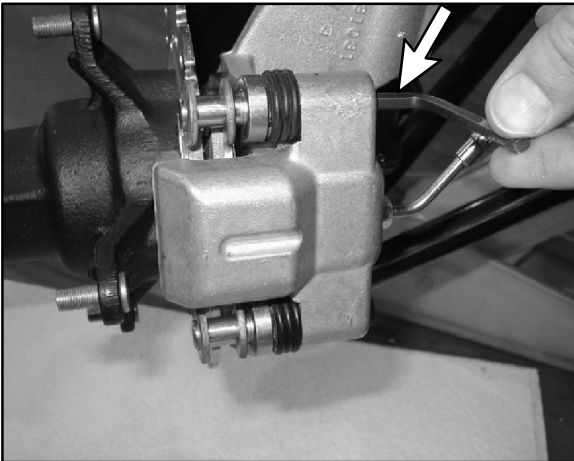

CAUTION:

Use care when supporting vehicle so that it does not tip or fall. Severe injury may occur if machine tips or falls.

2. Remove the front wheel. Loosen pad adjuster screw 2-3 turns.

3. Remove caliper from mounting bracket.

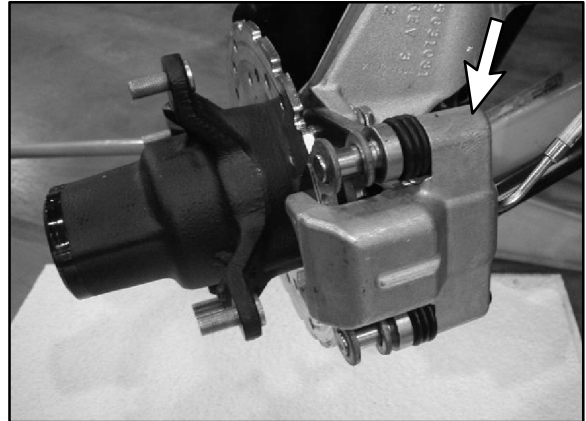

4. Push caliper piston into caliper bore slowly using a C-clamp or locking pliers with pads installed.

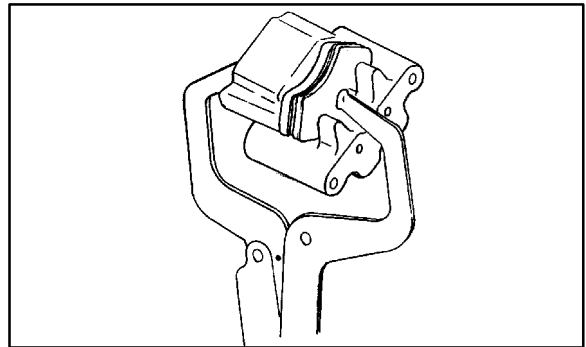

NOTE: Brake fluid will be forced through compensating port into master cylinder fluid reservoir when piston is pushed back into caliper. Remove excess fluid from reservoir as required.

5. Push mounting bracket inward and slip outer brake pad past edge. Remove inner pad.

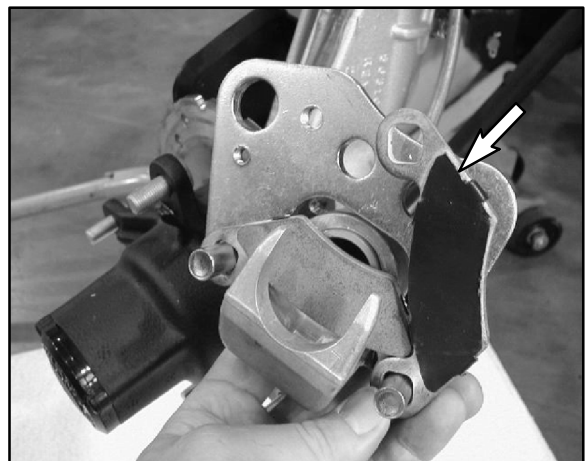



6. Measure the thickness of the pad material. Replace pads if worn beyond the service limit.

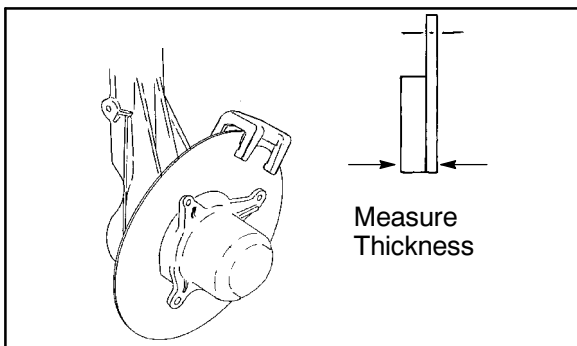

Front Brake Pad Thickness
 New .298" / 7.6 mm
 Service Limit .180" / 4.0 mm

FRONT PAD ASSEMBLY

1. Lubricate mounting bracket pins with a light film of Polaris Premium All Season Grease, and install rubber dust boots.



Polaris Premium All Season Grease
 (PN 2871423)

2. Compress mounting bracket and make sure dust boots are fully seated. Install pads with friction material facing each other. Be sure pads and disc are free of dirt or grease.



3. Install caliper on hub strut, and torque mounting bolts.

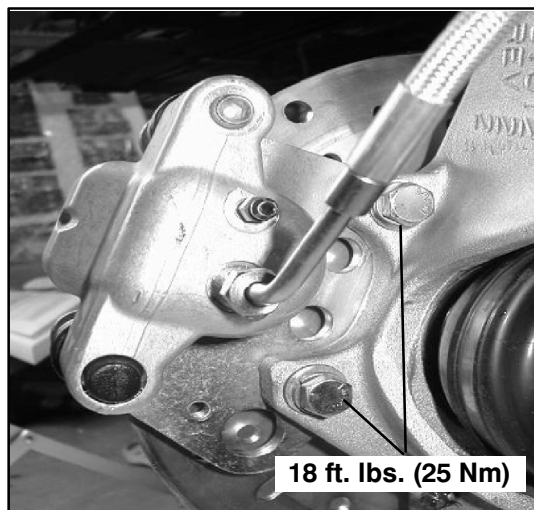

Front Caliper Mounting Bolts
 Torque: 18 ft. lbs. (25Nm)

4. Slowly pump the brake lever until pressure has been built up. Maintain at least 1/2" (12.7 mm) of brake fluid in the reservoir to prevent air from entering the brake system.



5. Install the adjuster screw and turn clockwise until stationary pad contacts disc, then back off 1/2 turn (counterclockwise).

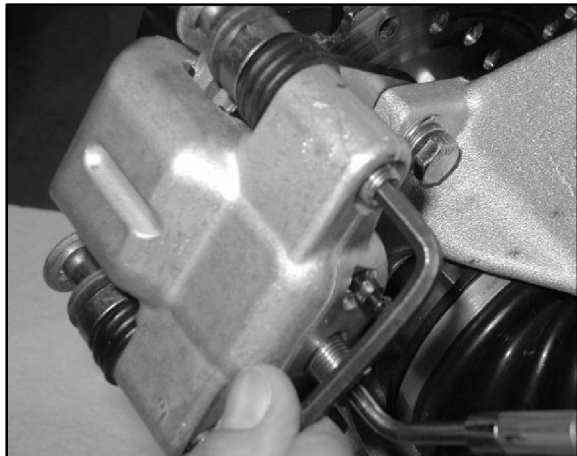

6. Verify fluid level in reservoir is up to MAX line inside reservoir and install reservoir cap.

Master Cylinder Fluid
Up to MAX line inside reservoir

7. Install wheels and torque wheel nuts.

Front Wheel Nut Torque
20 ft. lbs. (27 Nm)

BRAKE BURNISHING PROCEDURE

It is required that a burnishing procedure be performed after installation of new brake pads to extend service life and reduce noise.

Start machine and slowly increase speed to 30 mph. Gradually apply brakes to stop machine. Allow pads and disc to cool sufficiently during the procedure. Do not allow pads or disc to become hot or warpage may result. Repeat this procedure 10 times.

FRONT DISC INSPECTION

1. Visually inspect the brake disc for nicks, scratches, or damage.
2. Measure the disc thickness at eight different points around the pad contact surface using a 0-1" micrometer. Replace disc if worn beyond service limit.

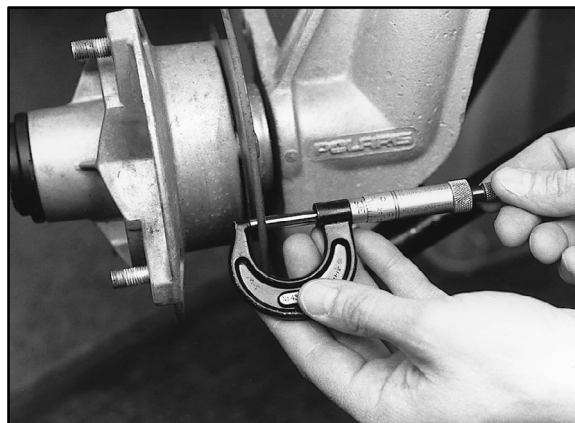

Brake Disc Thickness
New .150-.165" (3.81-4.19 mm)
Service Limit .140" / 3.556 mm

Brake Disc Thickness Variance
Service Limit: .002" (.051 mm)
difference between measurements.

3. Mount dial indicator as shown to measure disc runout. Slowly rotate the disc and read total runout on the dial indicator. Replace the disc if runout exceeds specifications.

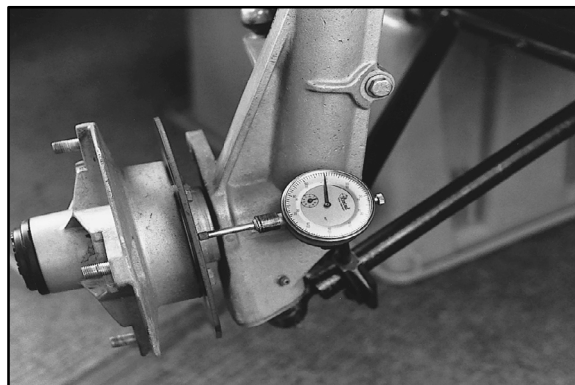

Brake Disc Runout
Service Limit .010" (.50 mm)

FRONT BRAKE DISC REMOVAL / REPLACEMENT

NOTE: To reduce the possibility of warpage, try removing the brake disc mounting bolts before applying heat to the bolts.



1. Apply heat to the hub in the area of the brake disc mounting bolts to soften the bolt locking agent.

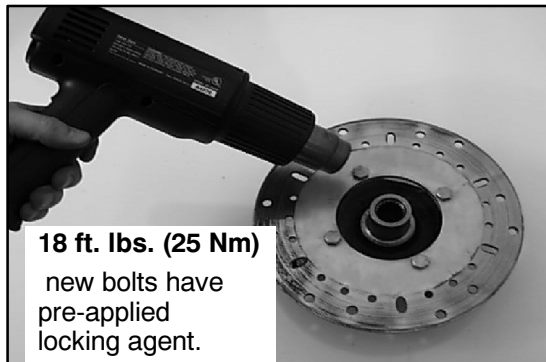

2. Remove bolts and disc.
3. Clean mating surface of disc and hub.
4. Install disc on hub.
5. Install new bolts and tighten to specified torque.

Front Brake Disc Mounting Bolt Torque

18 ft. lbs. (25 Nm)

CAUTION: Always use new brake disc mounting bolts. The bolts have a pre-applied locking agent which is destroyed upon removal.

FRONT CALIPER REMOVAL

CAUTION:

Use care when supporting vehicle so that it does not tip or fall. Severe injury may occur if machine tips or falls.

1. Remove brake pads. See Page 9.9.
2. Using a line wrench, loosen and remove brake line to caliper. Place a container under caliper to catch fluid draining from brake line.

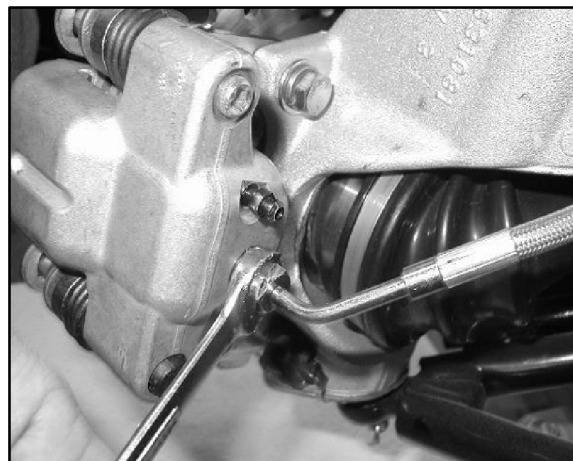

3. Remove brake caliper and drain fluid into container. Do not reuse brake fluid.

FRONT CALIPER DISASSEMBLY

1. Remove brake pad adjuster screw.

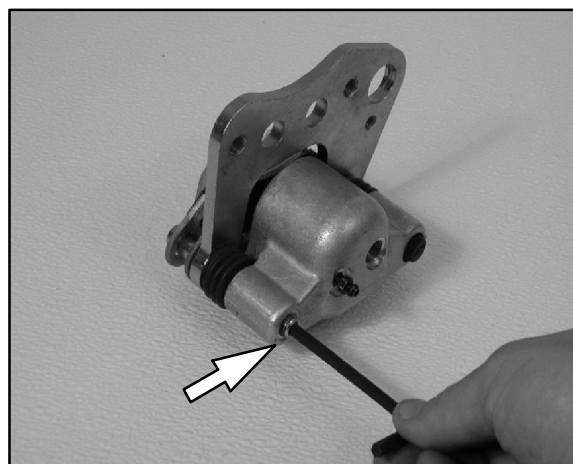

2. Push upper pad retainer pin inward and slip brake pads past edge.

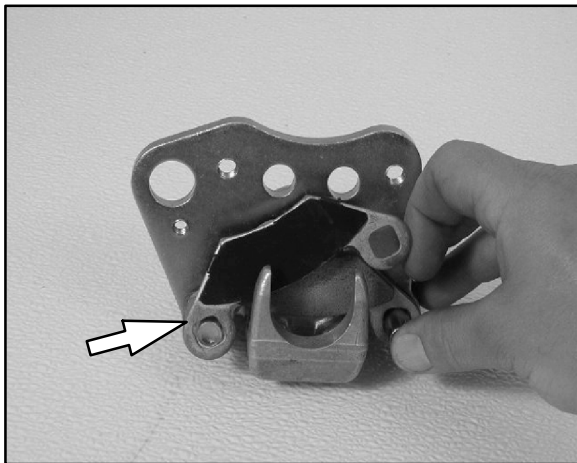

3. Remove mounting bracket, pin assembly and dust boot.

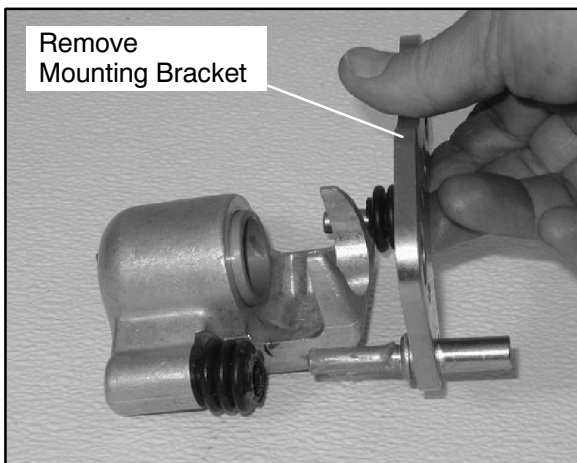

4. Remove piston, dust seal and piston seal.

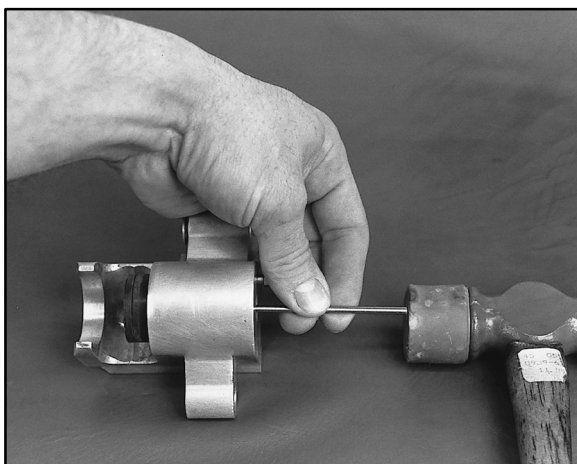

5. Clean the caliper body, piston, and retaining bracket with brake cleaner or alcohol.

NOTE: Be sure to clean seal grooves in caliper body.

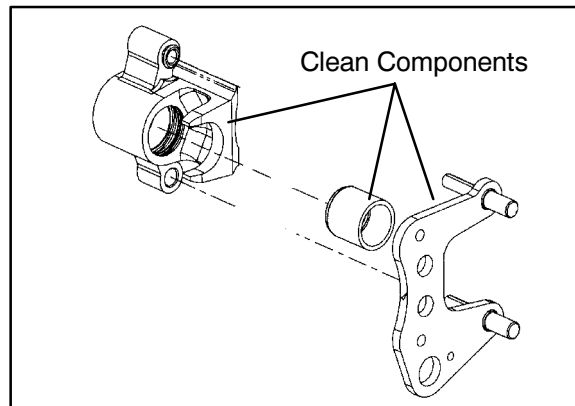

FRONT CALIPER INSPECTION

1. Inspect caliper body for nicks, scratches or wear. Measure bore size and compare to specifications. Replace if damage is evident or if worn beyond service limit.

Front Caliper Piston Bore I.D.
Std. 1.191-1.192" (30.25-30.28 mm)
Service Limit 1.193" (30.30 mm)



2. Inspect piston for nicks, scratches, wear or damage. Measure diameter and replace if damaged or worn beyond service limit.



3. Inspect the brake disc and pads as outlined for brake pad replacement this section. See Pages 9.10-9.11.

FRONT CALIPER REASSEMBLY

1. Install new O-rings (A) in the caliper body (B). Be sure groove is clean and free of residue or brakes may drag upon assembly.

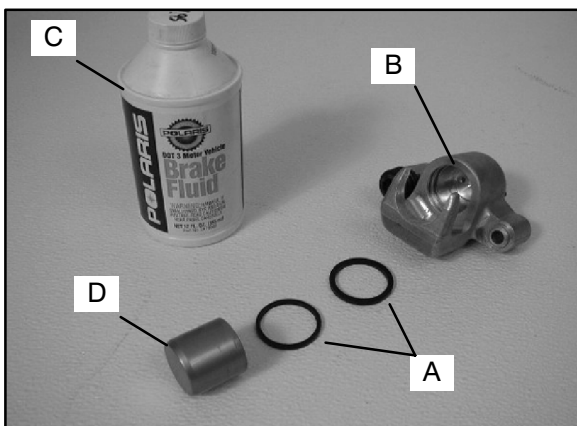

2. Coat piston with clean Polaris DOT 3 Brake Fluid (C). Install piston (D) with a twisting motion while pushing inward. Piston should slide in and out of bore smoothly, with light resistance.
3. Lubricate the mounting bracket pins with Polaris Premium All Season Grease, and install the rubber dust seal boots.



Polaris Premium All Season Grease

(PN 2871423)

4. Compress the mounting bracket and make sure the dust seals are fully seated. Install the pads as shown on Page 9.10. Clean the disc and pads with brake parts cleaner or denatured alcohol to remove any dirt, oil or grease.

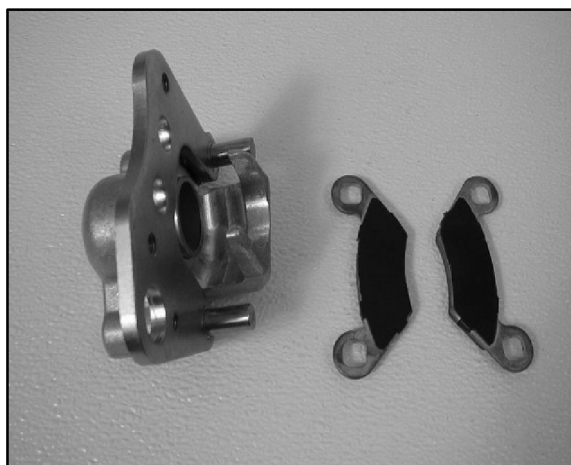



FRONT CALIPER INSTALLATION

1. Install caliper on hub strut, and torque mounting bolts.

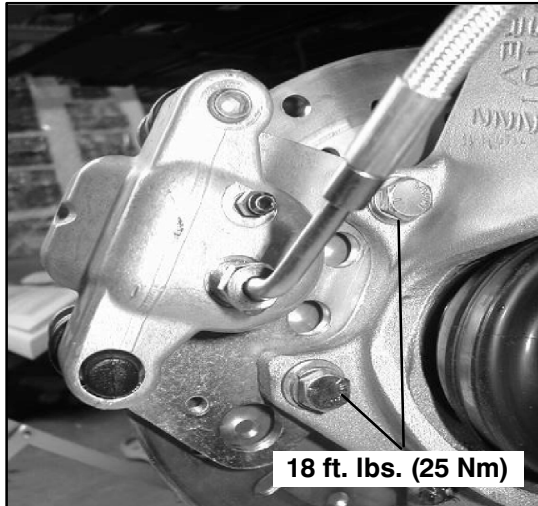

**Front Caliper Mounting Bolt Torque
18 ft. lbs. (25 Nm)**

2. Install brake line and tighten securely with a line wrench.
3. Install the adjuster screw and turn until stationary pad contacts disc, then back off 1/2 turn.

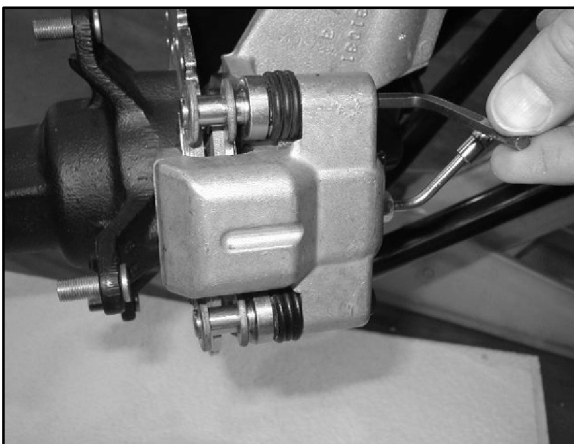

4. Follow brake bleeding procedure outlined on Pages 9.6-9.7.
5. Install wheels and torque wheel nuts to specification.

**Front Wheel Nut Torque
20 ft. lbs. (27 Nm).**



FRONT BRAKE CALIPER **EXPLODED VIEW**

3 APPLY POLARIS DOT 3 BRAKE FLUID TO COMPONENT

GREASE APPLY POLARIS ALL PURPOSE GREASE

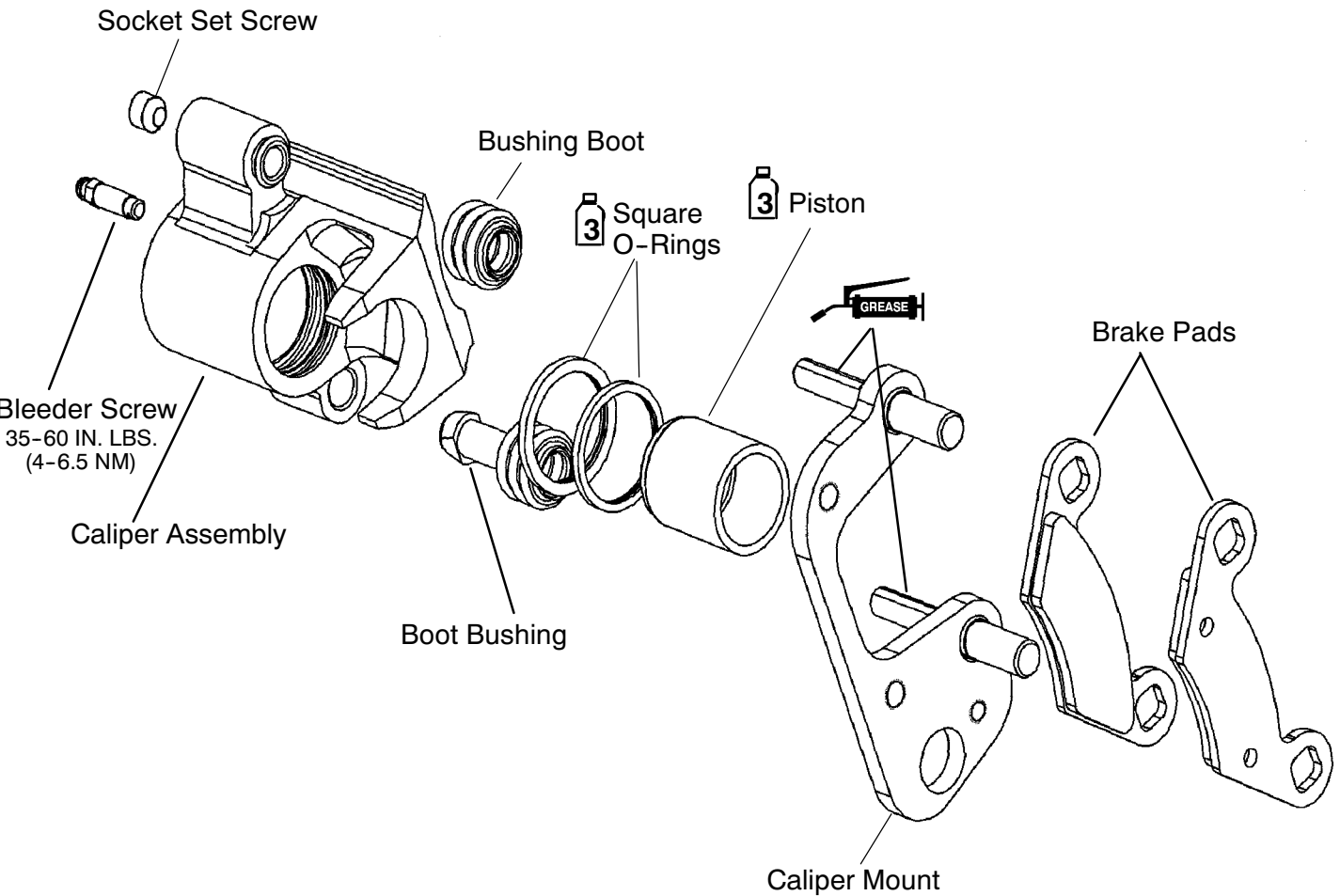



REAR BRAKE PAD REMOVAL

1. Remove caliper mounting bolts and lift caliper off of disc.

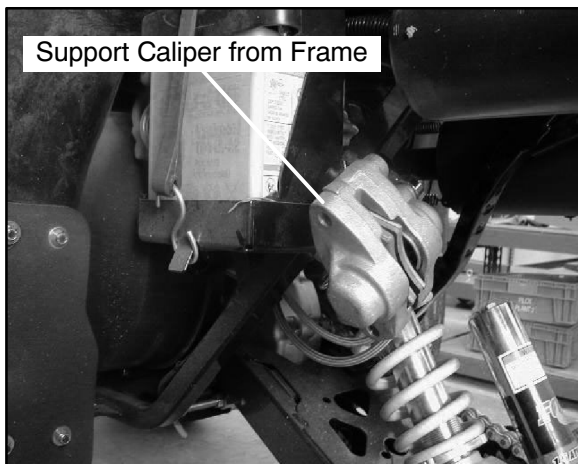

NOTE: When removing caliper, be careful not to damage brake line. Support caliper so as not to kink or bend brake line.

2. With pads installed, push the caliper pistons into their bores .

NOTE: Brake fluid will be forced through compensating port into master cylinder fluid reservoir when piston is pushed back into caliper. Remove excess fluid from reservoir as required.

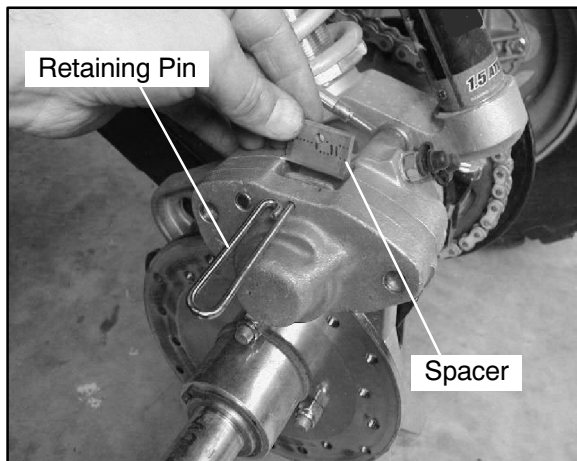

3. Remove brake pad retaining pin, and pad spacer.

NOTE: This is a spring pin, do not spread apart farther than necessary to remove it.

4. Measure the thickness of the pad material. Replace pads if worn beyond the service limit.

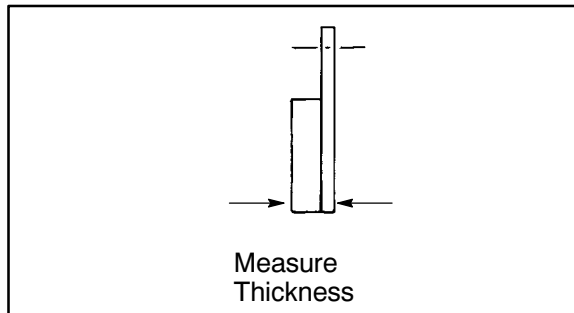

Rear Brake Pad Thickness
New .298 ± .005" (6.85 ± .127 mm)
Service Limit .150" (3.81 mm)

REAR BRAKE PAD INSTALLATION

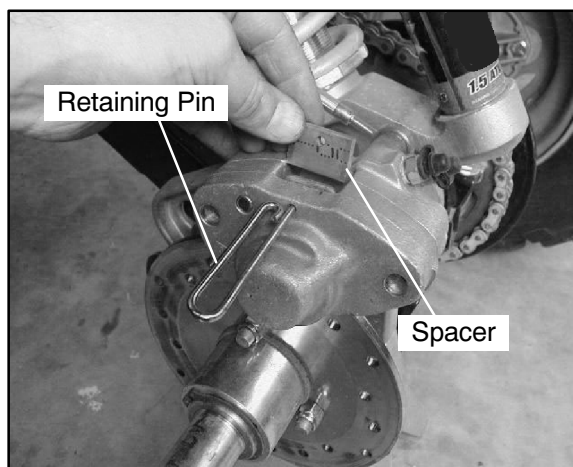

1. Install new pads in caliper body. Be sure to put aluminum spacer between pads. Install retainer.
2. Torque mounting bolts to specified torque.

DH Brake Caliper Mounting
Bolts Torque:
28 ft. lbs. (38 Nm)

3. Slowly pump the brake levers until pressure has been built up. Maintain at least 1/2" (12.7 mm) of brake fluid in the reservoir to prevent air from entering the master cylinder.



**Auxiliary Brake Master Cylinder
Fluid Level
Between MIN and MAX lines**

4. It is recommended that a burnishing procedure be performed after installation of new brake pads to extend service life and reduce noise. Start machine and slowly increase speed to 30 mph. Gradually apply brakes to stop machine. Repeat procedure 10 times.

REAR CALIPER REMOVAL/INSPECTION

1. Clean caliper area before removal.

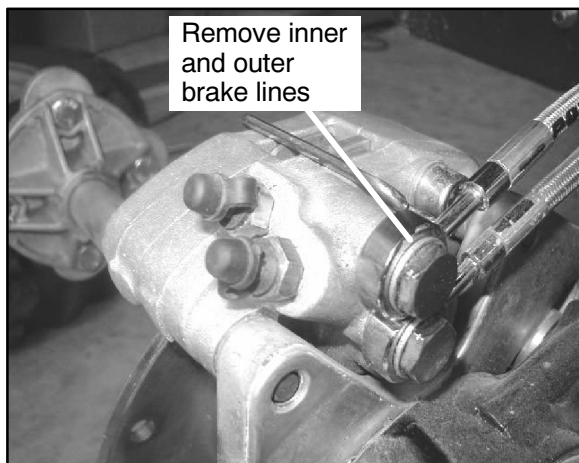

2. Using a wrench, remove left hand brake (outer) and right hand brake (inner) lines. Place a container to catch brake fluid draining from brake lines.

3. Remove the caliper and pads from the caliper.

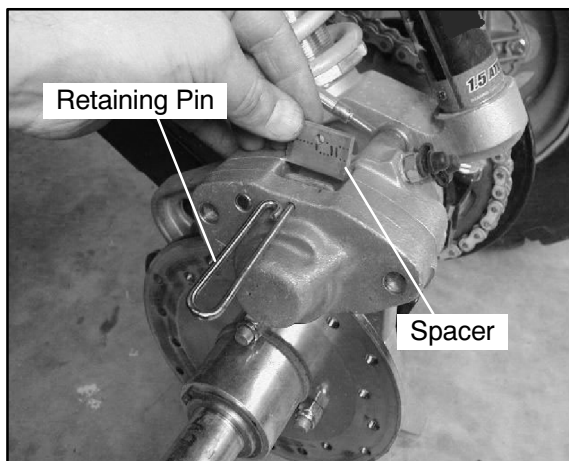

4. Remove Allen head screw and separate caliper halves and remove pistons with piston pliers.



5. Remove O-rings and clean O-ring grooves.
6. Clean disc, caliper body, and pistons with brake cleaner or alcohol.
7. Remove square-rings. Clean square-ring grooves.
8. Clean disc, caliper body, and piston with brake cleaner or alcohol.
9. Inspect caliper piston bores for scratches, severe corrosion, or galling and replace if necessary.

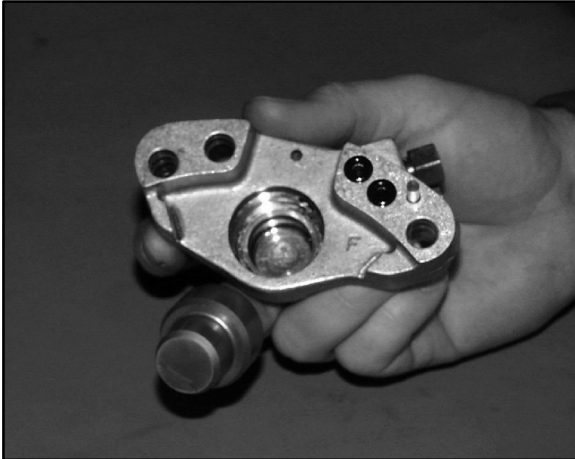

10. Inspect surface of caliper piston for nicks, scratches, or damage and replace if necessary.

REAR CALIPER ASSEMBLY

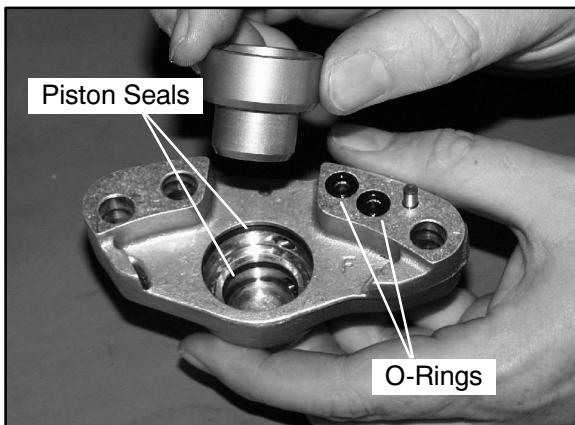

1. Install new square-rings on piston. Be sure square-ring grooves are thoroughly cleaned of all residue, or piston may bind in bore. Apply brake fluid to piston and install carefully with a twisting motion to ease assembly. Install dust seal on piston before fully seating piston.
2. Install new O-rings in caliper halves.
3. Carefully assemble caliper body, making sure O-rings are properly positioned in groove. Apply Loctite™ 242 (PN 2871949) to the allen head screw and torque body screw evenly to 18 ft. lbs. (25 Nm).

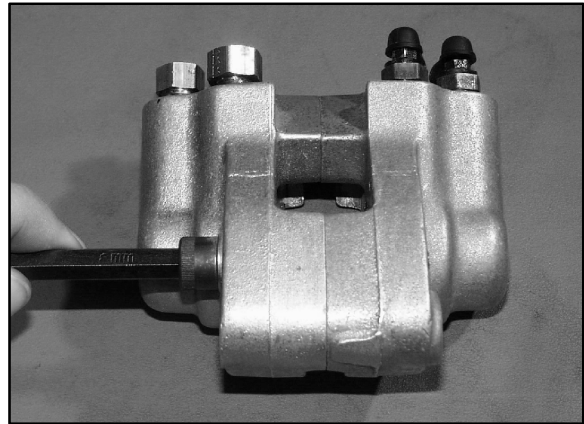

Caliper Halves Bolt Torque:
18 ft. lbs. (25 Nm)

4. Install brake pads in caliper body with friction material facing each other. If equipped with a pad spacer, install the spacer between the pads. Install retaining pin through outer pad, pad spacer and inner pad.
5. Install caliper and torque mounting bolts.

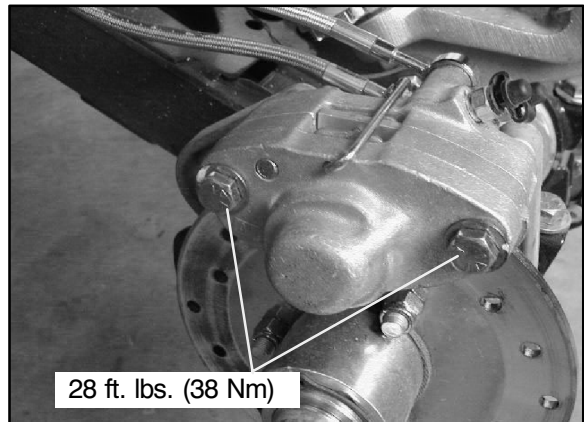

Caliper Mounting Bolt Torque
28 ft. lbs. (38 Nm)



6. Install brake lines and tighten to specified torque.

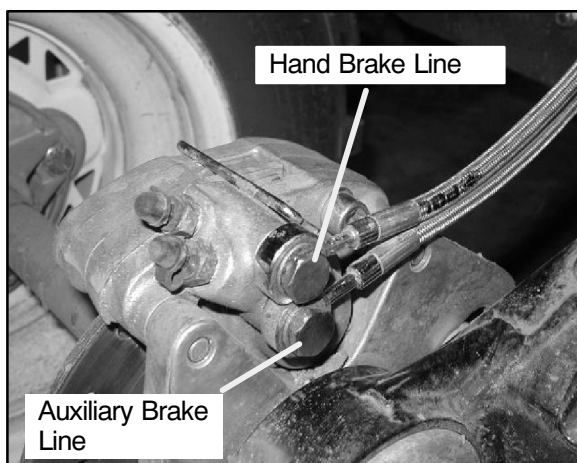

Banjo Bolt Torque
15 ft. lbs. (21 Nm)

7. Follow bleeding procedure outlined on Pages 9.6–9.7 of this section and refer to system overview and illustration on Page 9.5.
8. Field test unit for proper braking action before putting into service. Inspect for fluid leaks and firm brakes. Make sure the brake is not dragging when lever is released. If the brake drags, re-check assembly and installation.

REAR BRAKE DISC **INSPECTION**

1. Visually inspect disc for scoring, scratches, or gouges. Replace the disc if any deep scratches are evident.

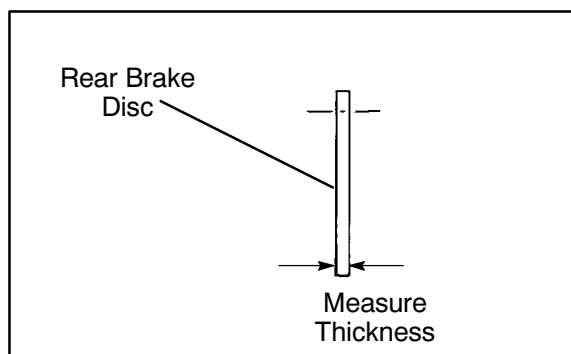

2. Use a 0-1" micrometer and measure disc thickness at 8 different points around perimeter of disc. Replace disc if worn beyond service limit.

Brake Disc Thickness
New .177-.188" (4.496-4.750 mm)
Service Limit .167" (4.242 mm)

Brake Disc Thickness Variance
Service Limit .002" (.051 mm)
difference between measurements

3. Mount dial indicator and measure disc runout. Replace the disc if runout exceeds specifications.

Brake Disc Runout
Service Limit .010" (.25 mm)



TROUBLESHOOTING

Brakes Squeal

- Dirty/contaminated friction pads
- Improper alignment
- Worn disc
- Worn disc splines

Poor Brake Performance

- Air in system
- Water in system (brake fluid contaminated)
- Caliper/disc misaligned
- Caliper dirty or damaged
- Brake line damaged or lining ruptured
- Worn disc and/or friction pads
- Incorrectly adjusted lever
- Incorrectly adjusted stationary pad
- Worn or damaged master cylinder or components
- Improper clearance between lever and switch

Lever Vibration

- Disc damaged
- Disc worn (runout or thickness variance exceeds service limit)
- Caliper Overheats (Brakes Drag)
- Compensating port plugged
- Pad clearance set incorrectly
- Auxiliary brake pedal incorrectly adjusted
- Brake lever or pedal binding or unable to return fully
- Parking brake left on
- Residue build up under caliper seals
- Operator riding brakes

Brakes Lock

- Alignment of caliper to disc.





DH (REAR AXLE MOUNTED) CALIPER/MASTER CYLINDER

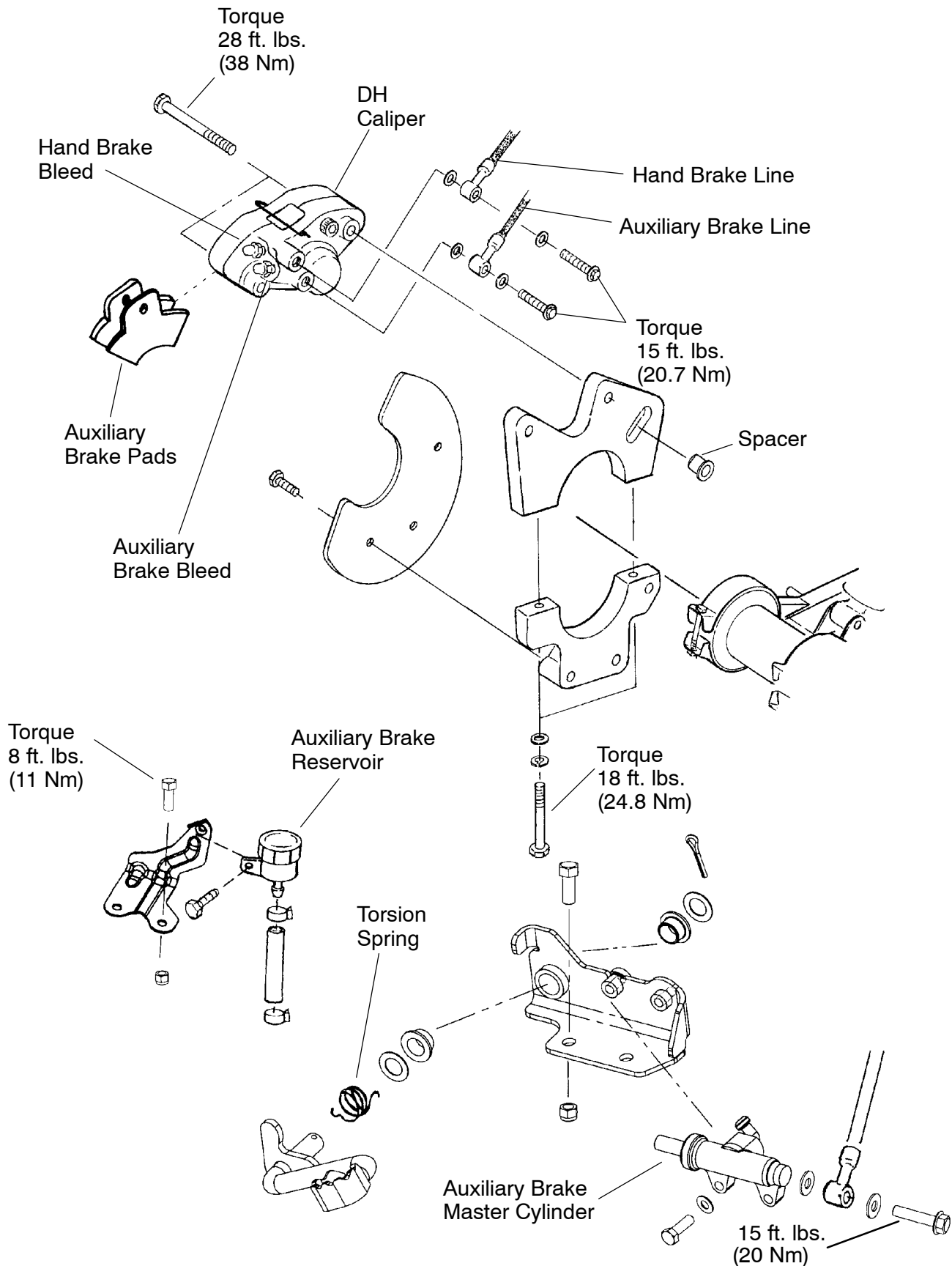

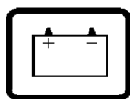

CHAPTER 10 ***ELECTRICAL***

Special Tools and Electrical Service Notes	10.2
Timing Check Procedure	10.2
Transmission Gear Position Switch Testing	10.3
Speed Limiter System/Troubleshooting	10.3-10.5
Oil Cooler Fan Circuit Operation	10.6
Thermistor / Fan Control Testing	10.6
Fan Motor Current Draw Test	10.6
Electronic Throttle Control System Operation . . .	10.7
Flywheel Identification - DC/CDI Operation	10.8
ES32PF 200 Watt Alternator, Exploded View	10.9
Ignition System Testing	10.10
Ignition System Troubleshooting	10.11
Cranking Output Tests	10.11
Charging System Testing	10.12-10.14
Battery Service	10.14-10.17
Headlight/Tail Light Service	10.18-10.19
Starter System Testing	10.20
Starter System Troubleshooting	10.21
Starter Motor Service	10.21-10.23
Starter Drive	10.24
Wiring Diagram	10.25

10



SPECIAL TOOLS

PART NUMBER	TOOL DESCRIPTION
PV-43568	Fluke™ 77 Digital Multimeter
2870836	Battery Hydrometer
2870630	Timing Light
8712100 or 8712500	Tachometer

ELECTRICAL SERVICE

NOTES

Keep the following notes in mind when diagnosing an electrical problem.

- Refer to wiring diagram for stator and electrical component resistance specifications.
- When measuring resistance of a component that has a low resistance value (under 10 Ohms), remember to subtract meter lead resistance from the reading. Connect the leads together and record the resistance. The resistance of the component is equal to tested value minus the lead resistance.
- Become familiar with the operation of your meter. Be sure leads are in the proper jack for the test being performed (i.e. 10A jack for current readings). Refer to the Owner's manual included with your meter for more information.
- Voltage, amperage, and resistance values included in this manual are obtained with a Fluke™ 77 Digital Multimeter (PV-43568). This meter is acceptable for use when diagnosing electrical problems. Readings obtained with other meters may differ.
- Pay attention to the prefix on the multimeter reading (K, M, etc.) and the position of the decimal point.
- For resistance readings, isolate the component to be tested. Disconnect it from the wiring harness or power supply.

TIMING CHECK PROCEDURES

- The ignition timing check hole is in the starter recoil/magneto housing. Remove the check plug.

NOTE: The ignition timing marks are stamped on the outside of the flywheel. Ignition timing must be inspected with the engine at room temperature (68°F / 20° C).

- With the transmission in neutral, start the engine and set engine speed to 5000 +/- 200 RPM.
- Direct the timing light at the ignition timing check hole and check the ignition timing. **NOTE:** Do not allow the engine to warm up. The timing will retard approximately 2° when the engine is warm.

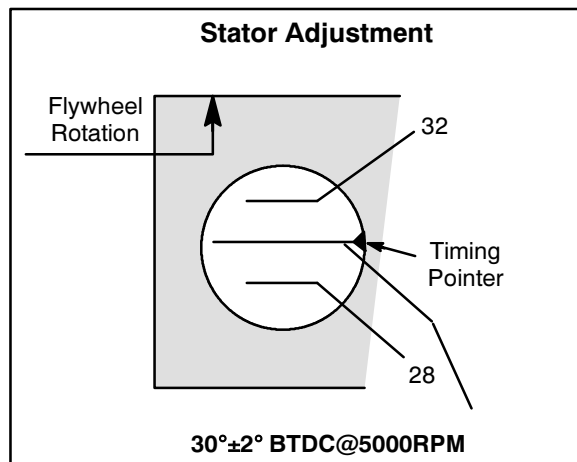

Stator Adjustment

If the ignition timing is not within the specified range, adjust the stator plate position as described below.

- Remove the magneto housing.
- Remove the flywheel.
- Loosen the stator plate screws and adjust the stator plate position. **NOTE:** Moving the stator plate clockwise retards (delays) the ignition timing. Moving the plate counterclockwise advances it.

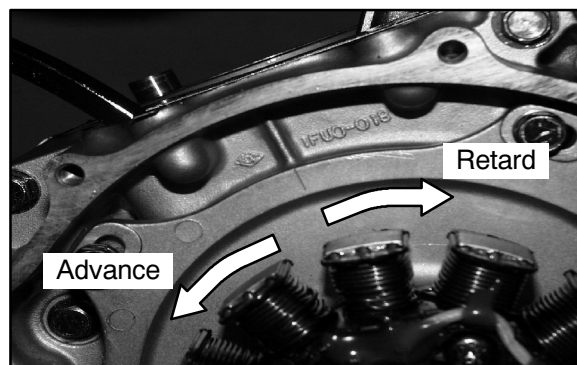

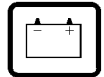

GEAR POSITION INDICATOR SWITCH TEST

Switch Continuity Table

High/Neutral/Reverse Switch

	D	C	B	A
High Range		●	●	
Reverse			●	●
Neutral	●			●

LIMITER SPECIFICATIONS

NOTE: The part number is printed on some late model LR modules. Whenever possible, use part number to identify the module. Modules may have same “LR” I.D. number, with different part numbers, terminals, and internal function.

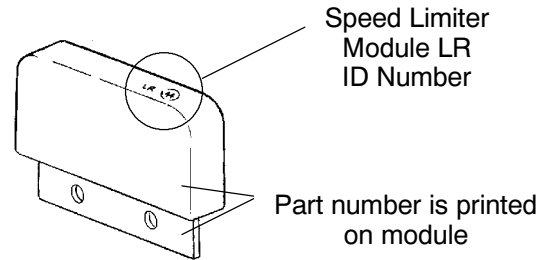

LIMITER SPECIFICATIONS		
(Refer to parts manual or microfiche for part number and application.)		
PART NO.	TYPE	FUNCTION / LIMIT RPM
4010137	LR44-3	Reverse Limit - 3500

NOTES

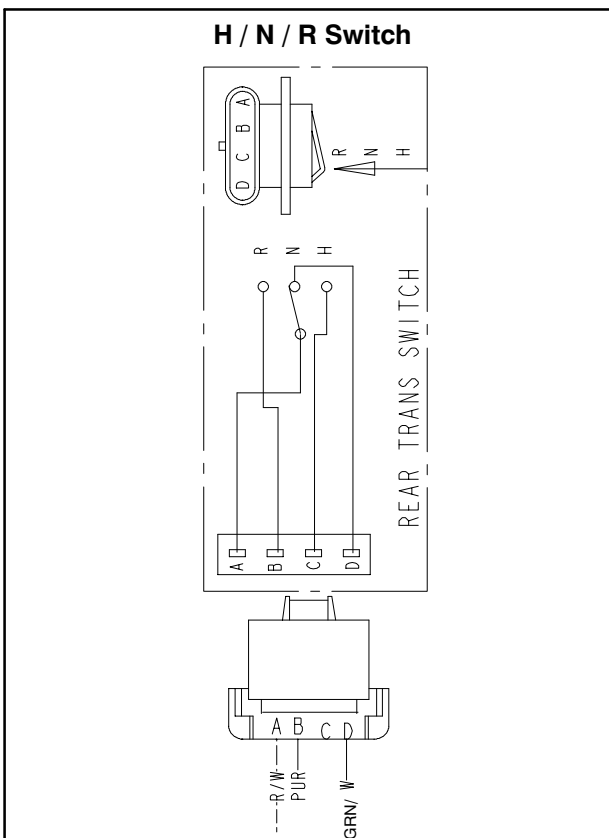



REVERSE LIMIT SYSTEM

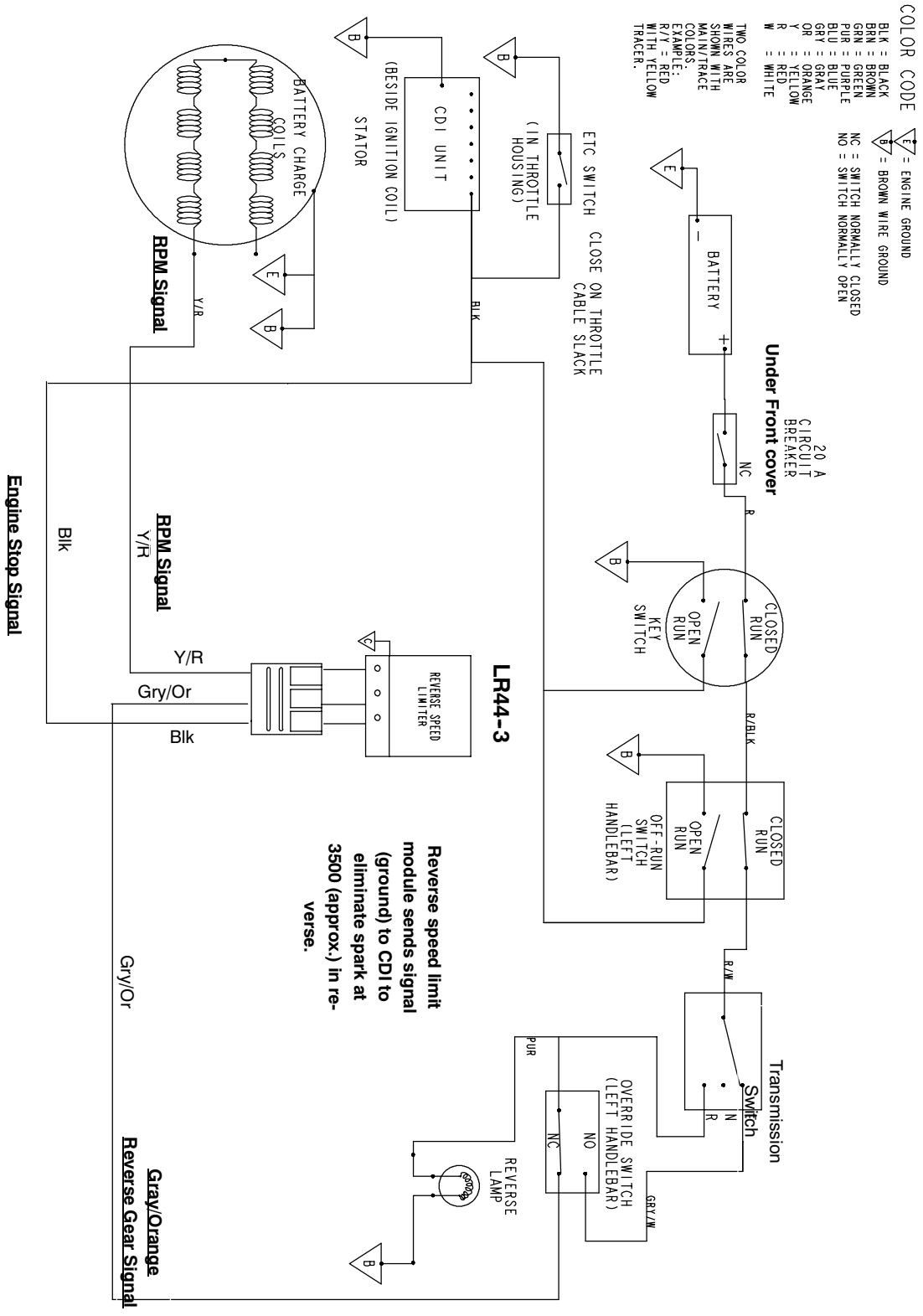

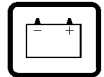

REVERSE SPEED LIMIT SYSTEM

APPLY PARKING BRAKE. START ENGINE.
SHIFT TO REVERSE GEAR

**NO REVERSE SPEED LIMIT
(LR44-3 Limit Module)**

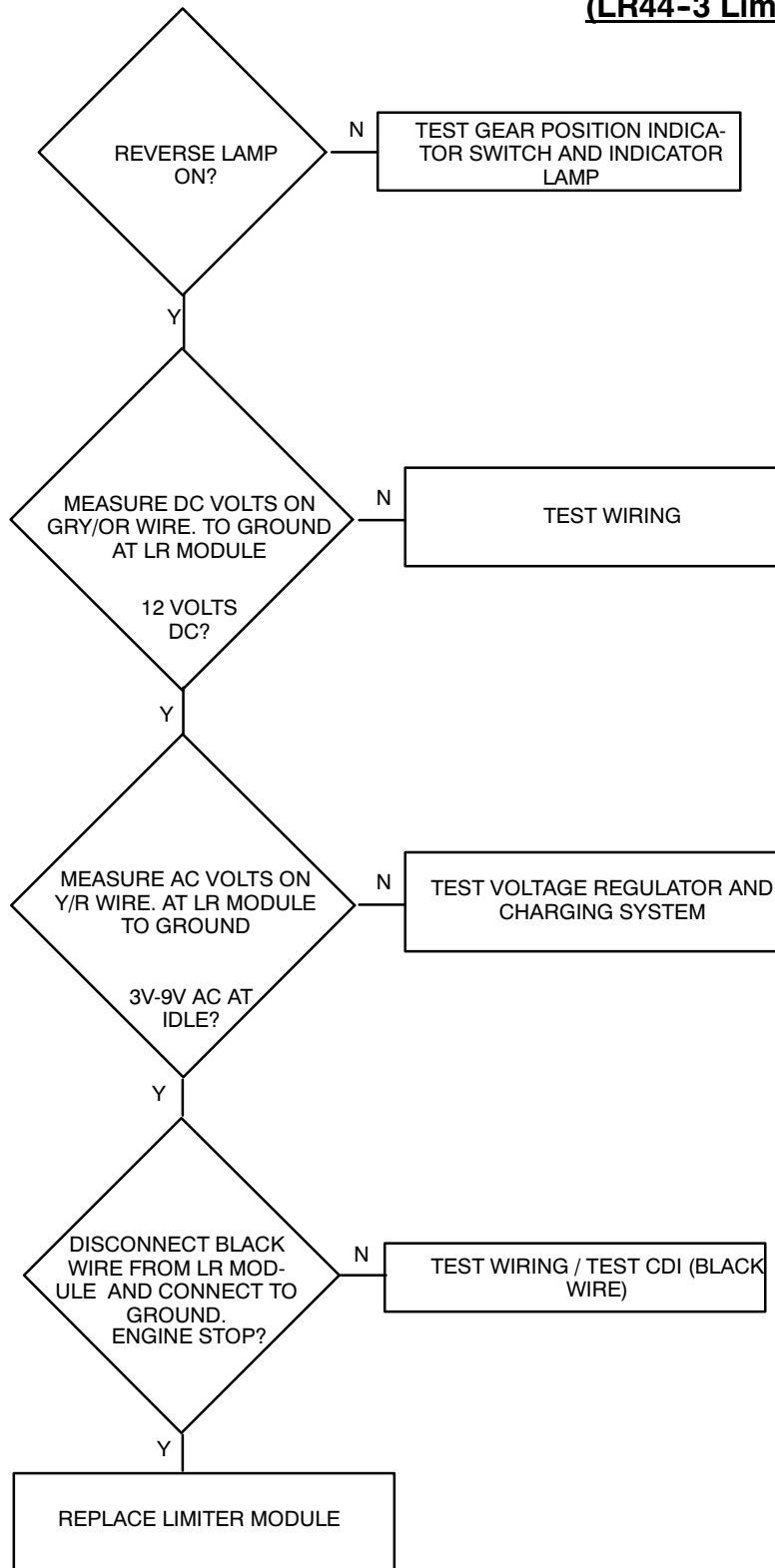



OIL COOLER FAN CONTROL

OIL COOLER FAN CIRCUIT

Hot light and fan "on" with leads connected

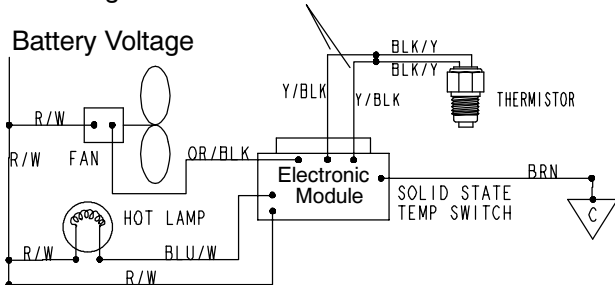

- Thermistor resistance decreases as temperature increases
- Both fan and hot light should be on with thermistor leads shorted together (low resistance)
- Fan blade should rotate drawing air in through cooler (blowing on engine)

THERMISTOR - RESISTANCE VS. TEMPERATURE

Temperature	Resistance \pm 20%	Fan ON/OFF	Hot Light ON/OFF
77° F (25° C)	100K Ω	Fan OFF	
240° F (116° C)	3.5K Ω	Fan OFF	
260° F (127° C)	2.5K Ω	Fan ON	
290° F (143° C)	1.6K Ω	Fan ON	Hot Light ON/OFF

THERMISTOR / FAN CONTROL TEST

- Turn ON and engine stop switch to RUN.
- Test voltage on R/W wire to ground - R/W wire should have 12 Volts DC (battery voltage)
- Short thermistor leads together - fan and hot light ON? (If not, test hot light, fan motor and circuit)
- Disconnect thermistor wires and test the resistance of the thermistor (refer to temperature/resistance table). Replace thermistor if out of specified range.
- Replace the module and test system.

FAN MOTOR CURRENT DRAW TEST

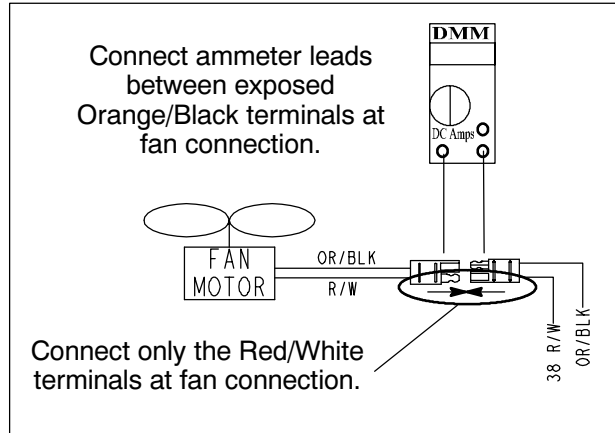

A current draw test will provide a good indication of fan motor condition. A worn or damaged fan motor will draw more current, which causes a reduction in blade speed and reduced cooling.

1. Turn key to off.
2. Disconnect the thermistor.
3. Reconnect fan motor connector to place a DC ammeter in series as shown in the Illustration.
4. Be sure fan blade is free to rotate.
5. Turn ignition key and engine stop switch to "ON" position. Read the current draw on ammeter with fan running.
6. If the fan motor draws more than 6.5 Amps, replace the motor.

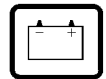

ELECTRONIC THROTTLE CONTROL (ETC) SWITCH (COMPOSITE THROTTLE HOUSING)

The Electronic Throttle Control (ETC) system is designed to stop the engine of an ATV in the event of a mechanical problem with the throttle mechanism. The ETC switch is mounted independently of the throttle actuator lever inside the throttle block assembly. This is a normally closed switch, and is held in the open position (contacts are separated as shown in Illustration 1) by throttle cable tension. The contacts are "open" in normal operation regardless of throttle lever position. In the event of a mechanical problem in the throttle mechanism (cable tension is lost), the switch contacts close, connecting the CDI black wire to ground, preventing ignition spark. This is the same as turning the key or engine stop switch "OFF".

Test the ETC switch at the harness connector. **NOTE:** Adjust throttle cable freeplay (ETC switch) and make sure throttle mechanism is functioning properly before testing the switch. Refer to Maintenance Chapter 2 for cable adjustment procedure.

ETC OPERATION TEST

1. Remove throttle block cover by carefully releasing all tabs around edge of cover.
2. Place transmission in neutral and apply parking brake.
3. Start engine and open throttle lever slightly until engine RPM is just above idle speed.
4. Hold throttle cable with fingers at point "A" as shown below and release throttle lever. If the ETC system is functioning properly, the engine will lose spark and stop.

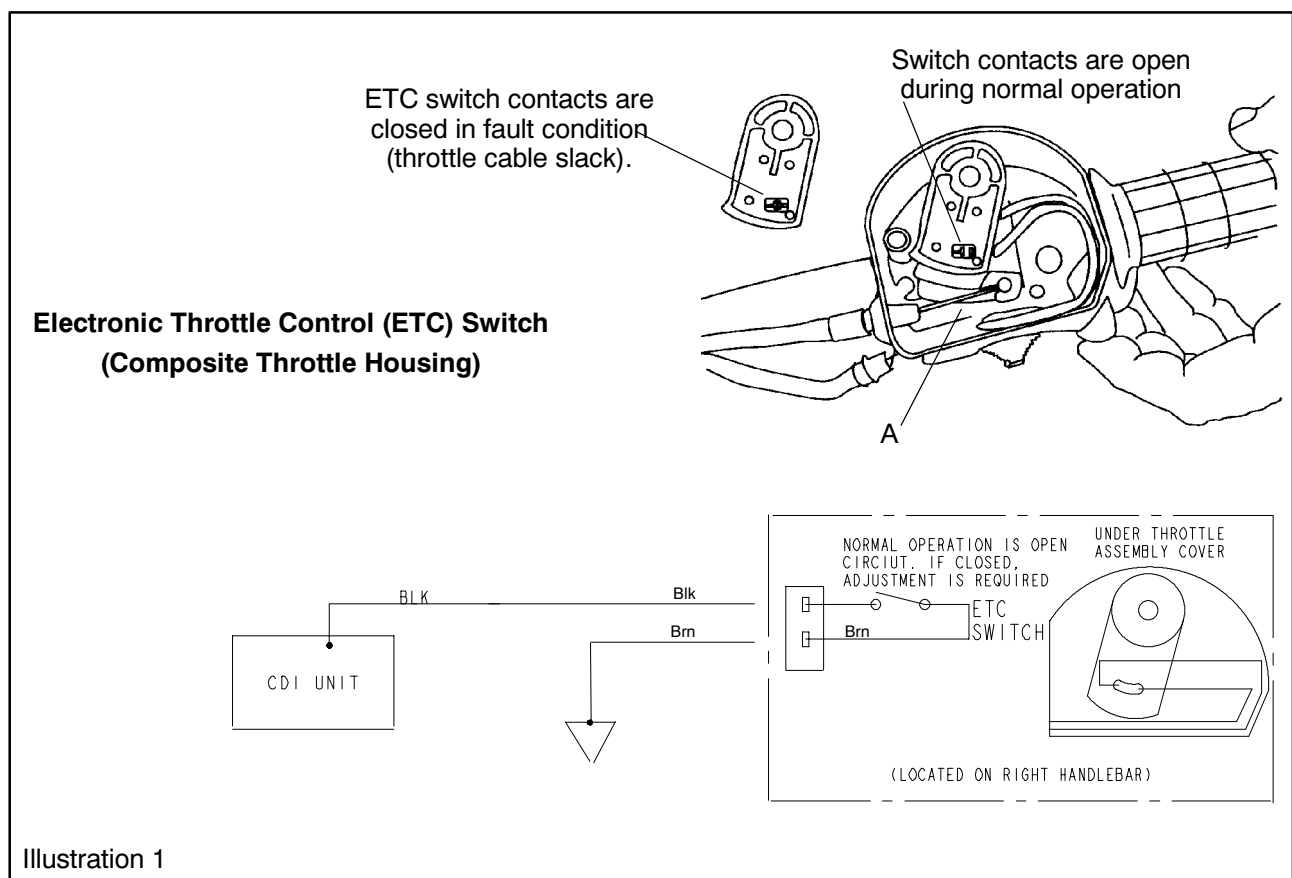



FLYWHEEL IDENTIFICATION

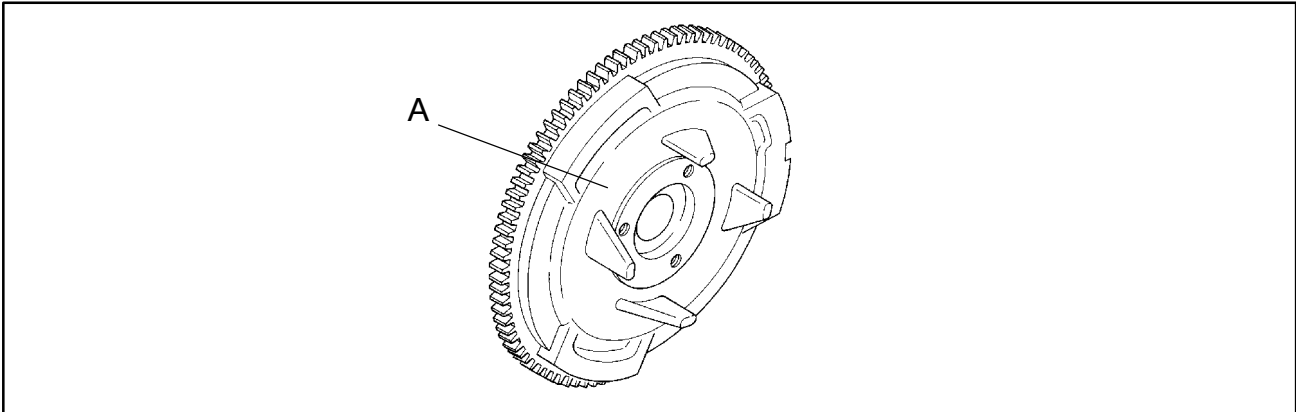

Flywheel Identification Stamp Location

The flywheel can be identified by the stamp mark in location A. Refer to "I.D." location in chart below. Do not use the cast mark to determine flywheel application.

2003 Engine Application	Type	Cast	Stamp	Comment	I.D. Stamp
Magnum ES32PFE10	N/A	N/A	N/A	200W	N/A

330 - DC/CDI IGNITION

The Trail Boss 330 has incorporated into its design a DC/CDI ignition system.

Some of the advantages of DC ignition are:

- Stronger, more consistent spark at low rpm for better performance
- Easier starts
- Simpler component design for ease of trouble shooting and maintenance

At the CDI, 12 volt DC current charges an internal capacitor to build up the initial ignition charge. A small A/C signal from the Trigger (Pulse) coil closes a thyristor (located in the CDI) at a point pre-determined in the crankshaft rotation by magnets on the flywheel's outer diameter. This signal releases the electrical charge which saturates the coil for ignition. DC/CDI systems have the ability to ignite with as little as 6 volts of power.

Operation Overview:

The DC/CDI system relies on battery power for ignition. Instead of generating DC voltage via magnetic induction, a 12 volt DC current is supplied directly to the CDI unit from the battery.

NOTE:

DC/CDI systems and components are not interchangeable with any other system.

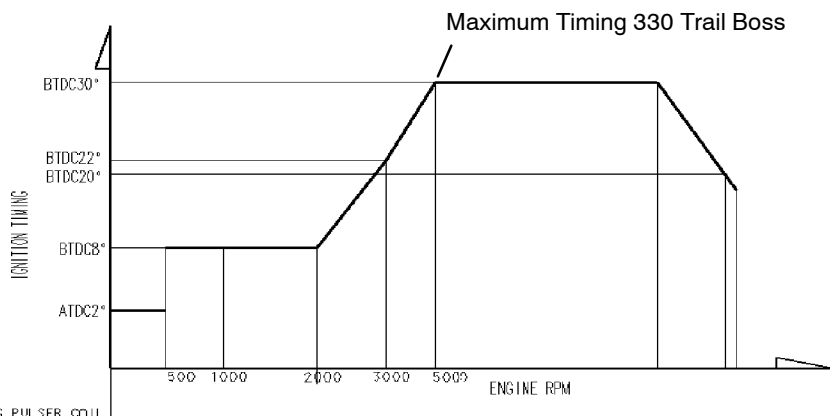

FIXED TIMING BY USING PULSER COIL



COMPONENTS OF ES32PF / 200 WATT ALTERNATOR

Note: DC/CDI components are not compatible with any other type of ignition

Refer To Wiring Diagrams For Specified Stator Coil Resistance

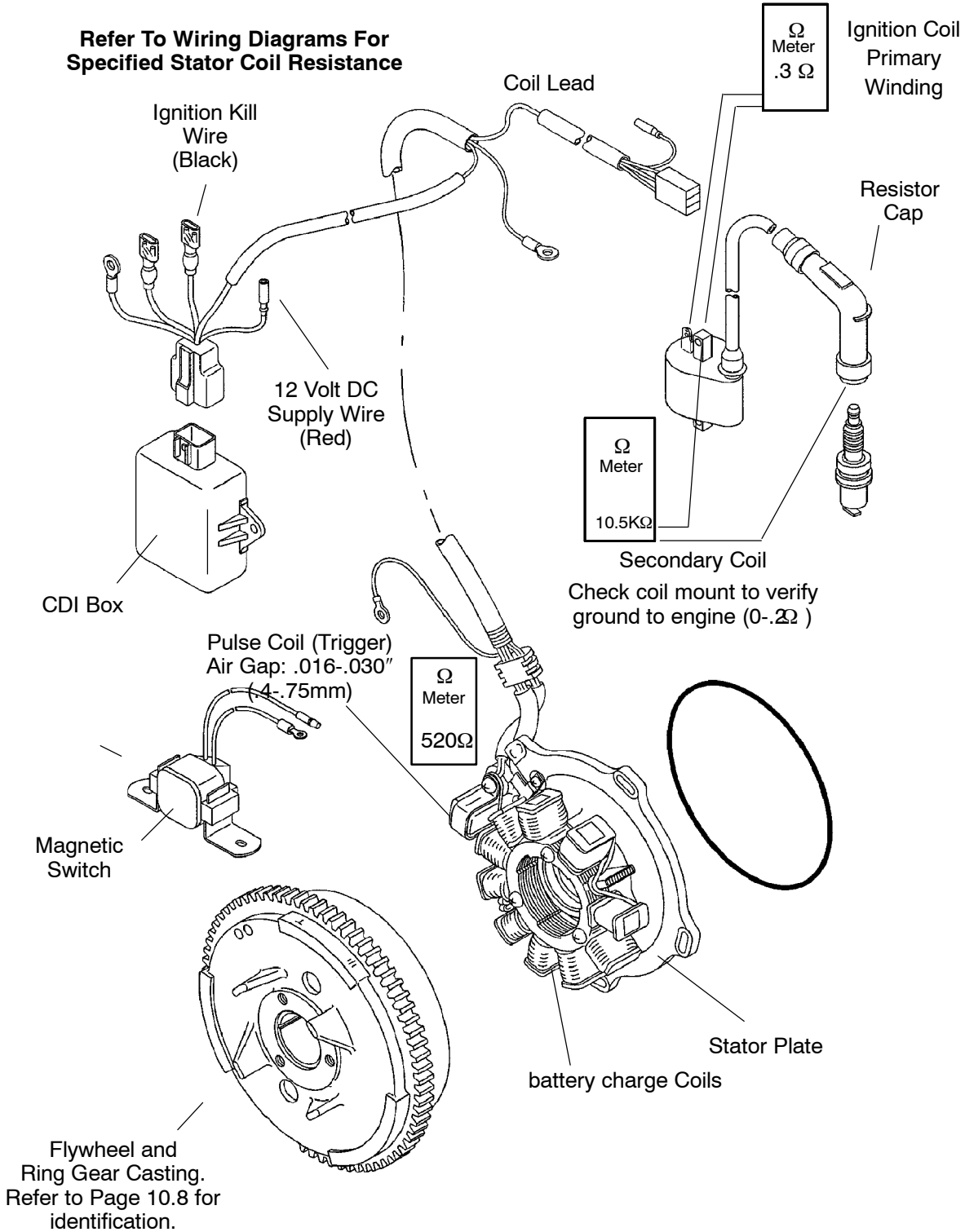



IGNITION SYSTEM TESTING

Whenever troubleshooting an electrical problem you should first check all terminal connections to be sure they are clean and tight. Also be sure that colors match when wires are connected. Use the following pages as a guide for troubleshooting. The resistance values are also given on the specification pages.

Condition: No Spark or intermittent spark

Verify 12 Volt DC power is present on the red wire to CDI. Replace Spark Plug.

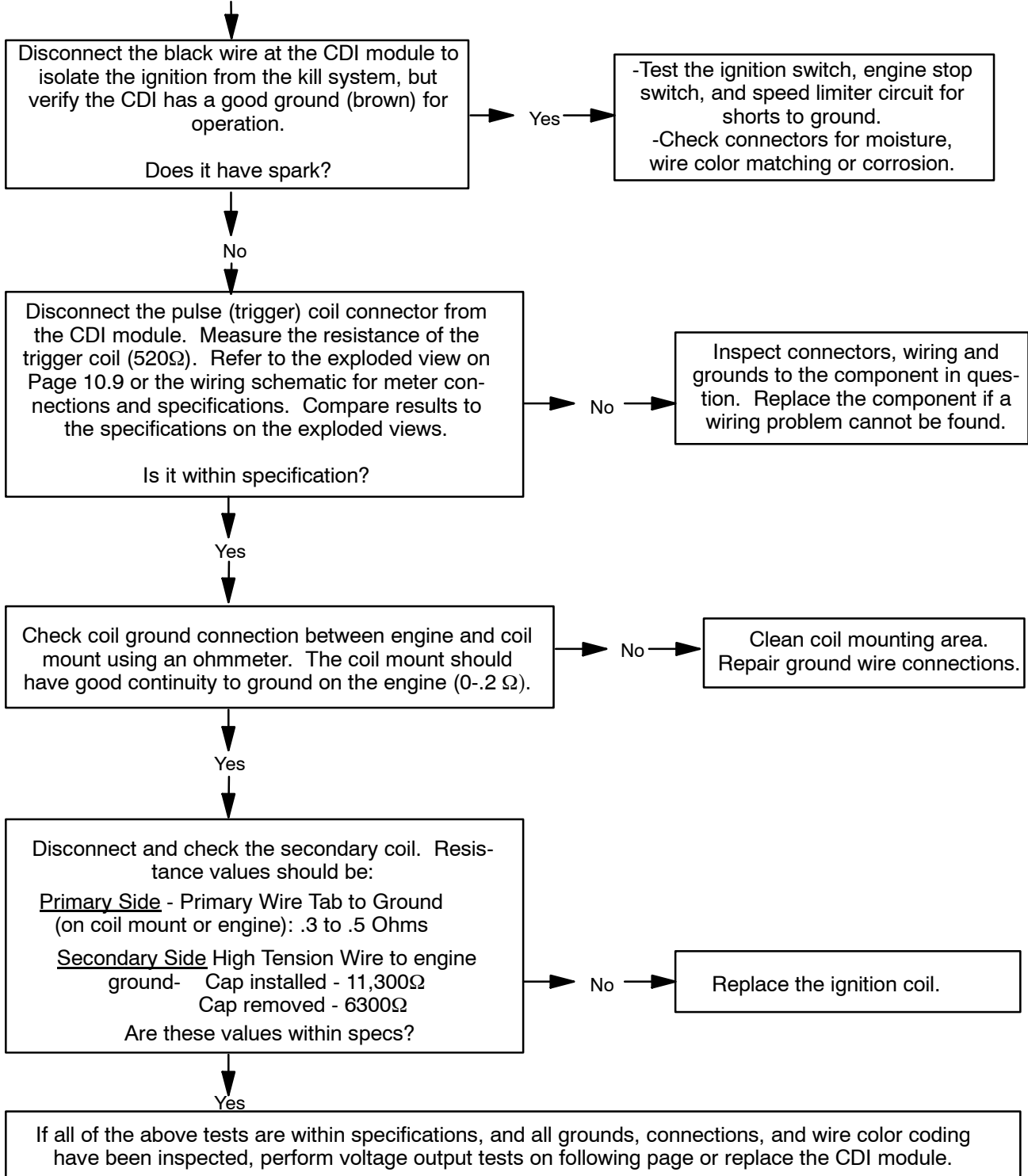

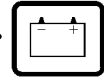

IGNITION SYSTEM TROUBLESHOOTING

No Spark, Weak or Intermittent Spark

- No 12 volt power or ground to CDI
- Spark plug gap incorrect
- Fouled spark plug
- Faulty spark plug cap or poor connection to high tension lead
- Related wiring loose, disconnected, shorted, or corroded
- Engine Stop switch or ignition switch faulty
- ETC switch misadjusted or faulty
- Poor ignition coil ground (e.g. coil mount loose or corroded)
- Faulty stator (measure resistance of all ignition related windings)
- Incorrect wiring (inspect color coding in connectors etc)
- Faulty ignition coil winding (measure resistance of primary and secondary)
- Worn magneto (RH) end Crankshaft bearings
- Sheared flywheel key
- Flywheel loose or damaged
- Excessive crankshaft runout on magneto (RH) end - should not exceed .005"
- Faulty CDI module

CRANKING OUTPUT TEST WITH PEAK READING VOLTMETER

The following peak voltage tests will measure the amount of output directly from each component. A peak reading voltmeter must be used to perform the tests. A variety of peak reading adaptors are commercially available for use with the Fluke™ 77 Digital Multimeter (**PV-43568**), which will allow peak voltage tests to be performed accurately. Follow the directions provided with the adaptor. All measurements are indicated in DC Volts. Readings obtained without a peak reading adaptor will be significantly different.

Test output from the CDI and pulse (trigger) coil and compare to the table. The following measurements are obtained when cranking the engine with the electric starter, spark plug installed. The starter system must be in good condition and the battery fully charged.

200 Watt 4 Stroke DC/CDI Ignition

Test	Connect Meter Wires To:	Reading (Without Peak Reading Volt meter)
CDI Output	Yellow Blue and Ground	20 DCV
Pulse (Trigger)	Yellow/Red and Yellow	3.3 DCV

CDI OUTPUT TEST USING PEAK READING ADAPTOR

Re-connect all CDI wires to stator wires. Disconnect CDI module wire from ignition coil primary terminal. Connect one meter lead to engine ground and the other to the ignition coil primary wire leading from the CDI module. Set meter to read DC Volts. Crank engine and check output of CDI wire to coil. Reconnect CDI wire to coil.

Output w/ Peak output tester
130 DCV
Average Output w/ Digital Voltmeter
20 DCV



CHARGING SYSTEM TESTING

Whenever charging system problems are suspected, proceed with the following system checks:

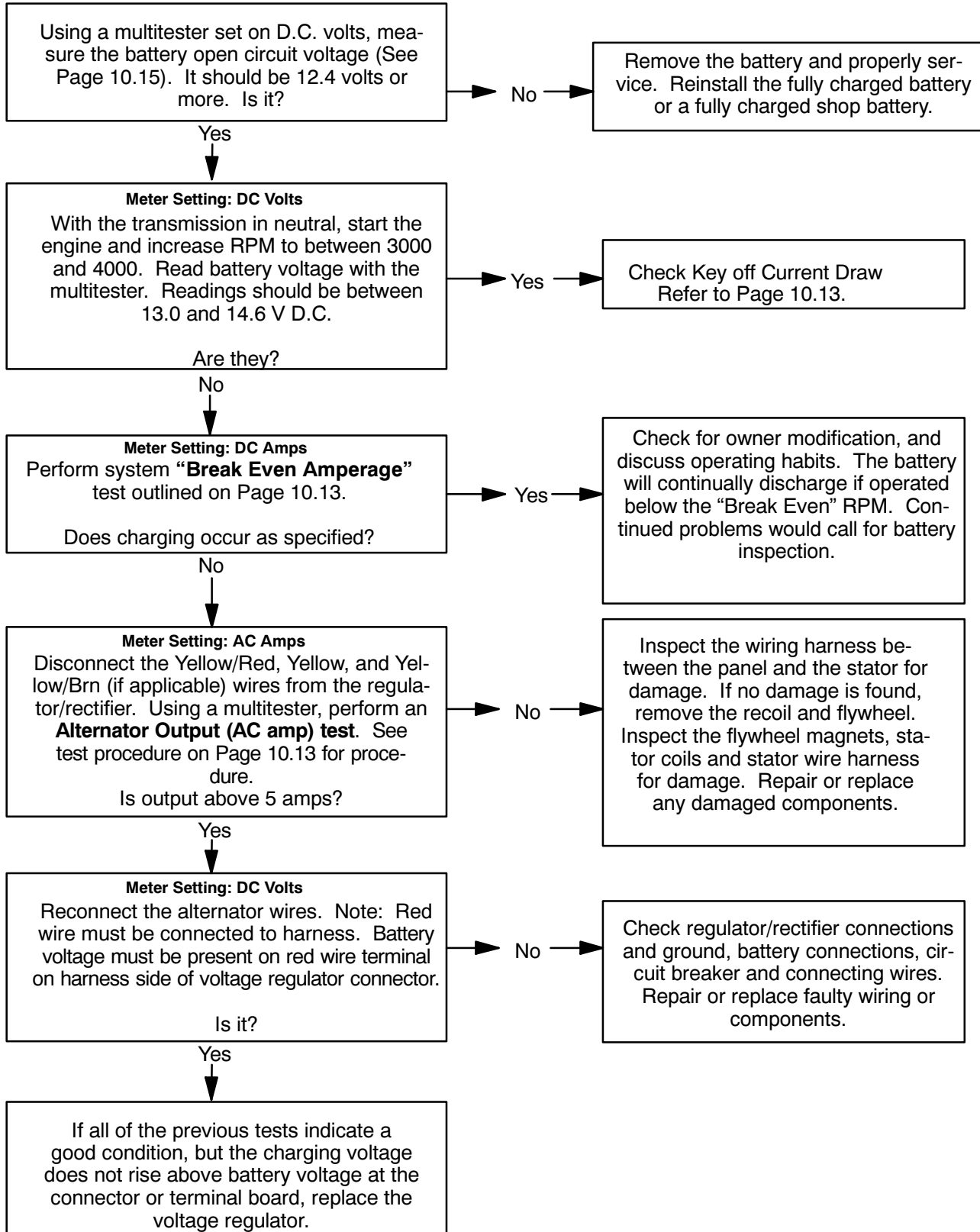

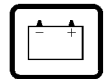

CURRENT DRAW - KEY OFF

CAUTION: Do not connect or disconnect the battery cable or ammeter with the engine running. Damage will occur to light bulbs and speed limiter.

Connect an ammeter in series with the negative battery cable. Check for current draw with the key off. If the draw is excessive, loads should be disconnected from the system one by one until the draw is eliminated. Check component wiring as well as the component for partial shorts to ground to eliminate the draw.

**Current Draw - Key Off:
Maximum of .02 DCA (20 mA)**

CHARGING SYSTEM “BREAK EVEN” TEST

CAUTION: Do not connect or disconnect the battery cable or ammeter with the engine running.

CAUTION: Never use the electric starter with the ammeter connected, as damage to the meter or meter fuse may result. Do not run test for extended period of time. Do not run test with high amperage accessories.

The “break even” point of the charging system is the point at which the alternator overcomes all system loads (lights, etc.) and begins to charge the battery. Depending on battery condition and system load, the break even point may vary slightly. The battery should be fully charged before performing this test.

- Connect an ammeter (set to DC amps) in series between the negative battery cable and terminal.

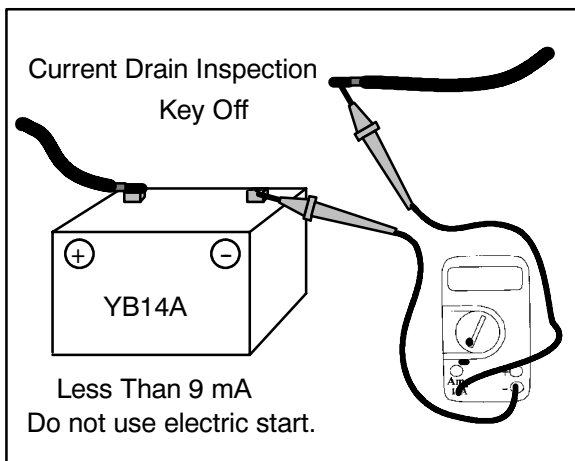

- Connect a tachometer according to manufacturer’s instructions.

- With engine off and the key and kill switch in the ON position, the ammeter should read negative amps (battery discharge). Reverse meter leads if a positive reading is indicated.
- Shift transmission into neutral. **Start engine with recoil only.**
- Increase engine RPM while observing ammeter and tachometer.
- Note RPM at which the battery starts to charge (ammeter indication is positive).
- With lights and other electrical load off, this should occur at approximately 1500 RPM or lower.
- Turn the lights on and lock parking brake to keep brake light on.
- Repeat test, observing ammeter and tachometer. With lights on, charging should occur at or below 2000 RPM.

ALTERNATOR OUTPUT TEST (AC AMP)

This test measures AC amperage from the alternator.

CAUTION: This test simulates a “full load” on the alternator. Do not perform this test longer than required to obtain a reading or the alternator stator windings may overheat. Do not exceed idle rpm during this test.

To Calculate Available Alternator Output

$$I = \frac{P}{E} \quad \frac{150W}{12V} = 12.5 \text{ Amps}$$

I = Current in Amps
P = Power in Watts
E = Electromotive Force (Volts)

**Alternator Current Output:
Minimum of 7 AC Amps**

- Maximum alternator output will be indicated on the meter. It is *not* necessary to increase engine RPM above idle.
- Place the red lead on the tester in the 10A jack.



- Turn the selector dial to the AC amps (A~) position.
- Connect the meter leads to the Yellow and Yellow/Red wires leading from the alternator.
- Start the engine and let it idle. Reading should be a minimum of 7A at idle.

BATTERY SERVICE

⚠ WARNING

Battery electrolyte is poisonous. It contains sulfuric acid. Serious burns can result from contact with skin, eyes or clothing. Antidote:

Internal: Drink large quantities of water or milk. Follow with milk of magnesia, beaten egg, or vegetable oil. Call physician immediately.

Eyes: Flush with water for 15 minutes and get prompt medical attention.

Batteries produce explosive gases. Keep sparks, flame, cigarettes, etc. away. Ventilate when charging or using in an enclosed space. Always shield eyes when working near batteries. **KEEP OUT OF REACH OF CHILDREN**

WARNING: The gases given off by a battery are explosive. Any spark or open flame near a battery can cause an explosion which will spray battery acid on anyone close to it. If battery acid gets on anyone, wash the affected area with large quantities of cool water and seek immediate medical attention.

The battery is located under the left rear fender.

BATTERY TERMINALS/BOLTS

Use Polaris corrosion resistant Dielectric Grease (PN 2871329) on battery bolts. See Battery Installation on Page 10.15.

MAINTENANCE-FREE BATTERY INSPECTION

NOTE: All 2003 Trail Boss ATV batteries are Maintenance-Free design and construction. All Maintenance-Free batteries are fully charged and tested at the factory before installation. Expected shelf life is 6-8 months depending on storage conditions. As a general rule before placing the battery into service, check the battery condition and charge accordingly .

New Batteries: Batteries must be fully charged before use or battery life can be reduced by 10-30% of full potential. Charge battery for 3-5 hours at a current equivalent of 1/10 of the battery's rated amp/hour capacity (i.e. 12amp hr x .10 = 1.2 amp charging). Do not use the alternator to charge a new battery.

Maintenance-Free batteries are permanently sealed at the time of manufacture. The use of lead-calcium and AGM technology instead of lead-antimony allows the battery acid to be fully absorbed. For this reason, a Maintenance-Free battery case is dark and the cell caps are not removable, since there is no need to check electrolyte level.

NEVER attempt to add electrolyte or water to a Maintenance-Free battery. Doing so will damage the case and shorten the life of the battery. Refer to the Battery Maintenance Video (PN 9917987) for proper instruction on servicing Maintenance-Free batteries.

To service a Maintenance-Free battery:

1. Remove battery from the vehicle
2. Test battery with a voltage meter or load tester to determine battery condition. This will determine the length of time required to charge the battery to full capacity. Refer to capacity table on Page 10.15.
3. Charge battery at 1/10 of its amp/hour rating. Example: 1/10 of 12 amp battery = 1.2 amp charge rate.

CONVENTIONAL LEAD-ACID BATTERY INSPECTION

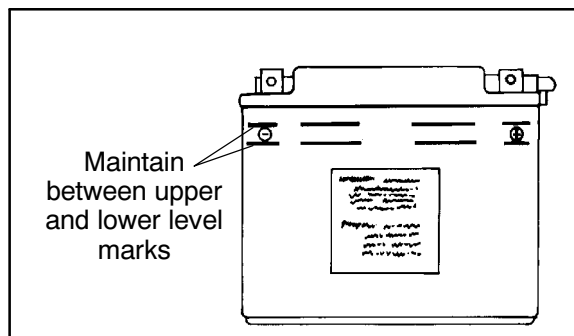

NOTE: Use these procedures **ONLY** if the Maintenance-Free battery has been replaced with a Conventional Lead-acid type.

1. Inspect the battery fluid level. When the battery fluid nears the lower level, the battery should be removed and distilled water should be added to the upper level line.

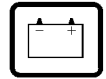

To remove the battery:

1. Disconnect holder strap and remove cover.
2. Disconnect battery negative (-) (black) cable first, followed by the positive (+) (red) cable.

CAUTION

Whenever removing or reinstalling the battery, disconnect the negative (black) cable first and reinstall the negative cable last!

To activate a NEW conventional lead/acid battery:

1. Remove vent plug and battery cell caps.
2. Fill battery with electrolyte to upper level marks on case.
3. Set battery aside and allow it to cool and stabilize for 30 minutes.
4. Add electrolyte to bring level back to upper level mark on case. **NOTE:** *This is the last time that electrolyte should be added. If the level becomes low after this point, add only distilled water.*
5. Charge battery at 1/10 of its amp/hour rating. Example: 1/10 of 14 amp battery = 1.4 amp

To charge an existing conventional lead/acid battery:

1. Disconnect the vent hose.
2. Remove the battery.
3. Remove the filler caps and add *distilled water only* as needed to bring each cell to the proper level. Do not overfill the battery.

 To refill use only distilled water. Tap water contains minerals which are harmful to a battery.

4. Reinstall the battery caps.
5. Charge battery at 1/10 of its amp/hour rating. Example: 1/10 of 14 amp battery = 1.4 amp
6. Reinstall the battery after testing.

BATTERY INSTALLATION

1. Clean battery cables and terminals with a stiff wire brush. Corrosion can be removed using a solution of one cup water and one tablespoon baking soda. Rinse will with clean water and dry thoroughly.

2. Reinstall battery, attaching positive (+) (red) cable first and then the negative (-) (black) cable. Coat terminals and bolt threads with Dielectric Grease (PN 2871329).
3. (*Conventional Lead/Acid Batteries Only*) Install clear battery vent tube from vehicle to battery vent. **WARNING:** Vent tube must be free from obstructions and kinks and securely installed. If not, battery gases could accumulate and cause an explosion. Vent should be routed away from frame and body to prevent contact with electrolyte. Avoid skin contact with battery electrolyte, severe burns could result. If electrolyte contacts the vehicle frame, corrosion will occur.
4. Route cables so they are tucked away in front and behind battery.
5. Reinstall battery cover and holder strap.

 Do not run the engine with the battery disconnected. Electrical components can become damaged.

BATTERY TESTING

Whenever a service complaint is related to either the starting or charging systems, the battery should be checked first.

Following are three tests which can easily be made on a battery to determine its condition: OCV Test, Specific Gravity Test (Conventional Lead-acid batteries only) and Load Test.

OCV - OPEN CIRCUIT VOLTAGE TEST

Battery voltage should be checked with a digital multimeter. Readings of 12.6 volts or less require further battery testing and charging. See charts and Load Test on Page 10.16.

NOTE: Lead-acid battery electrolyte levels should be kept between the low and full marks. If the battery is stored or used in a partially charged condition, or with low electrolyte levels, crystal sulfation will form on the plates, reducing the efficiency and service life of the battery.



SPECIFIC GRAVITY TEST

NOTE: This test is for Conventional Lead-acid batteries only. Maintenance-Free batteries cannot be opened.

A tool such as a Battery Hydrometer (PN 2870836) can be used to measure electrolyte strength or specific gravity. As the battery goes through the charge/discharge cycle, the electrolyte goes from a heavy (more acidic) state at full charge to a light (more water) state when discharged. The hydrometer can measure state of charge and differences between cells in a multi-cell battery. Readings of 1.270 or greater should be observed in a fully charged battery. Differences of more than .025 between the lowest and highest cell readings indicate a need to replace the battery.

LOAD TEST

CAUTION: Remove spark plug high tension leads and connect securely to engine ground before proceeding.

NOTE: This test can only be performed on engines with electric starters. This test cannot be performed with an engine or starting system that is not working properly.

A battery may indicate a full charge condition in the OCV test and the specific gravity test, but still may not have the storage capacity necessary to properly function in the electrical system. For this reason, a battery capacity or load test should be conducted whenever poor battery performance is encountered. To perform this test, hook a multimeter to the battery in the same manner as was done in the OCV test. The reading should be 12.6 volts or greater. Engage the electric starter and view the registered battery voltage while cranking the engine. Continue the test for 15 seconds. During this cranking period, the observed voltage should not drop below 9.5 volts. If the beginning voltage is 12.6 volts or higher and the cranking voltage drops below 9.5 volts during the test, replace the battery.

OFF SEASON STORAGE

To prevent battery damage during extended periods of non-use, the following basic battery maintenance items must be performed:

- Remove the battery from the machine and wash the case and battery tray with a mild solution of baking soda and water. Rinse with fresh water after cleaning. **NOTE:** Do not get any baking soda into the battery or the acid will be neutralized.
- Using a wire brush, remove any corrosion from the cables and terminals.
- Make sure that the electrolyte is at the proper level. Add distilled water if necessary.
- Charge at a rate no greater than 1/10 of the battery's amp/hr capacity until the electrolyte's specific gravity reaches 1.270 (12.7 volts) or greater.
- Store the battery either in the machine with the cables disconnected or place the battery on a piece of wood and store in a cool place.

CHARGING PROCEDURE

Charge the battery with a charger no larger than 1/10 of the battery's amp/hr rating for as many hours as needed to raise the specific gravity to 1.270 or greater.

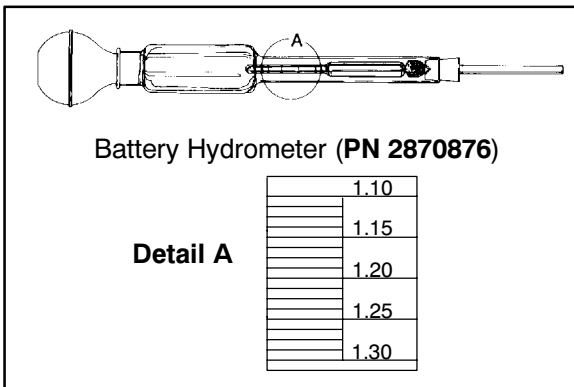

OPEN CIRCUIT VOLTAGE		
State of charge	Conventional Lead-acid	Maintenance Free
100% Charged	12.60V	12.70V
75% Charged	12.40V	12.50V
50% Charged	12.10V	12.20V
25% Charged	11.90V	12.0V
0% Charged	less than 11.80V	less than 11.9V

SPECIFIC GRAVITY		
State of charge*	Conventional lead-acid	Maintenance Free
100% Charged	1.265	n/a
75% Charged	1.210	
50% Charged	1.160	
25% Charged	1.120	
0% Charged	less than 1.100	

* At 80° F **NOTE:** Subtract .01 from the specific gravity reading when testing. At 40° F, add .01 to the specific gravity.

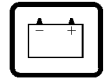

NOTE: Stored batteries lose their charge at the rate of 1% per day. They should be recharged to a full charge every 30 to 60 days during a non-use period. If the battery is stored during the winter months the electrolyte will freeze at a higher temperature as the battery discharges. The chart at below indicates freezing points by specific gravity.

Electrolyte Freezing Points	
Specific Gravity of Electrolyte	Freezing Point
1.265	-75° F
1.225	-35° F
1.200	-17° F
1.150	+5° F
1.100	+18° F
1.050	+27° F

1. Install battery in vehicle with positive terminal toward the front. Coat threads of battery bolt with a corrosion resistant dielectric grease.

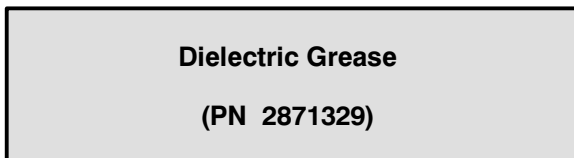

WARNING: To avoid the possibility of explosion, connect positive (red) cable first and negative (black) cable last.

2. Connect battery cables.
3. After connecting the battery cables, install the cover on the battery and attach the hold down strap.
4. (Conventional Lead-acid batteries only) Install clear battery vent tube from vehicle to battery vent. **WARNING:** Vent tube must be free from obstructions and kinks and securely installed. If not, battery gases could accumulate and cause an explosion. Vent should be routed away from frame and body to prevent contact with electrolyte. Avoid skin contact with battery electrolyte, severe burns could result. If electrolyte contacts the vehicle frame, corrosion will occur.
5. Route cables so they are tucked away in front and behind battery.

HEADLIGHT ADJUSTMENT

The headlight beam can be adjusted up and down and side to side.

1. Place the vehicle on a level surface with the headlight approximately 25' (7.6 m) from a wall.

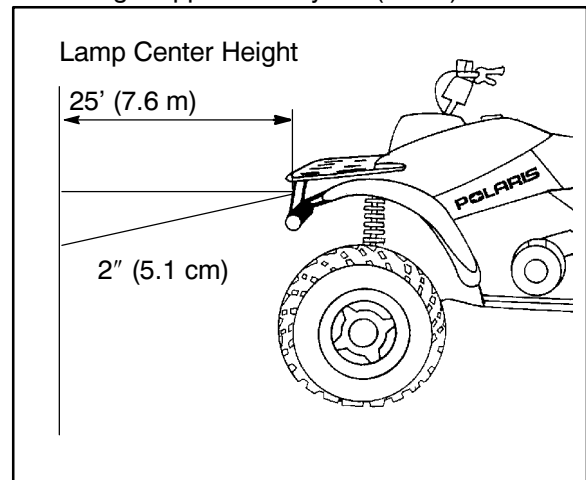

2. Measure the distance from the floor to the center of the headlight and make a mark on the wall at the same height.
3. Shift transmission to neutral, start the engine and turn the headlight switch to high beam.
4. Observe headlight aim. The most intense part of the headlight beam should be aimed 2" (5.1 cm) below the mark placed on the wall in Step 2. **NOTE:** Rider weight must be included on the seat. For machines with separate low beam lights, the drop should be 8" (20.3 cm) in 25'.
5. Adjust beam to desired position by moving headlight.

HEADLIGHT LAMP REPLACEMENT

NOTE: Allow lamp to cool before proceeding. Do not touch a halogen lamp with bare fingers. Oil from your skin leaves a residue, causing a hot spot which will shorten the life of the lamp. Hold the bulb by the base only.

Headlight Assembly Removal

1. Carefully unsnap the electrical harness from the back of the headlight assembly and remove the harness.
2. Remove the screws and nuts from the sides of the headlight assembly.
3. Remove the headlight assembly.



Headlamp Replacement

1. With the headlight assembly in place, unsnap the electrical harness from the back the headlight assembly.
2. Turn and pull out the connector on the back of the headlight assembly. Gently pull the bulb out and replace with the new bulb. Snap the harness back into place.

TAILLIGHT/BRAKELIGHT LAMP REPLACEMENT

If the taillight/brakelight does not work the lamp may need to be replaced.

1. From the rear of the taillight remove two screws holding lens cover in place and remove lens cover.

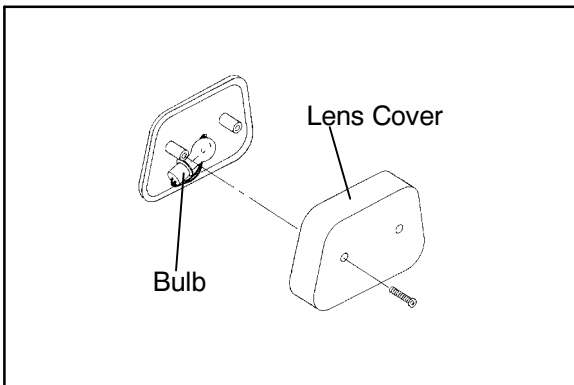

2. Remove lamp and replace it with recommended lamp. Apply Dielectric Grease (**PN 2871329**).
3. Reinstall the lens cover removed in Step 1.
4. Test the taillight/brakelight to see that it's working.

POD ASSEMBLY REMOVAL / INDICATOR LAMP REPLACEMENT

1. Remove the two screw covers (A) and screws from the pod assembly (B).

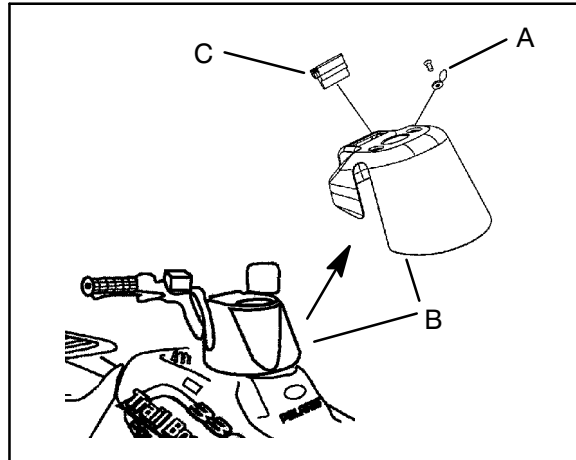

2. Disconnect indicator light panel from harness, by lifting the retaining latch from the wire connector.

NOTE: The indicator panel (C) does not have to be remove from the pod to replace an indicator light.

3. To remove defective light: Use a small screwdriver and turn light holder a quarter turn, pull light holder out with a needle nose pliers or equivalent. Replace with new holder and bulb assembly and reassemble pod.

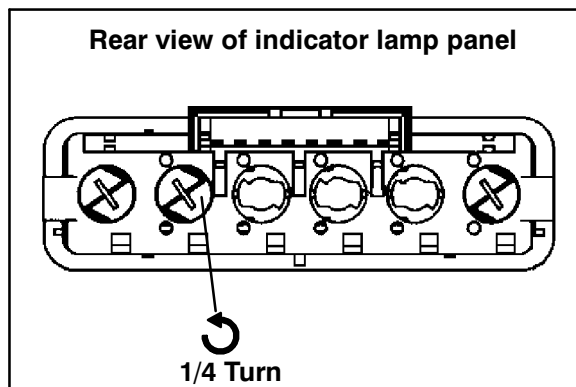

4. Reverse the above steps for installation.

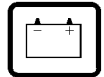

HEADLAMP SWITCH

Follow procedure, Headlight Lamp Replacement, on Page 10.17-10.18 to access connector. Probe the headlamp plug wires (Brown, Green, Yellow) at back of connector. Turn headlight on. Test for battery voltage across the connections.

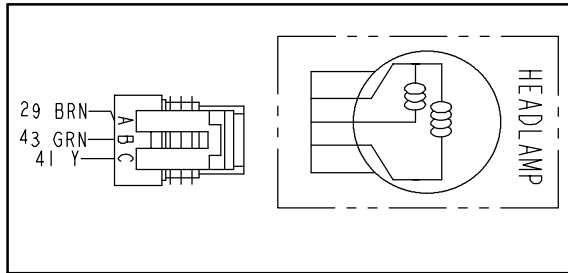

Check continuity across pins of the left handle bar switch assembly. See illustration below.

Continuity

	R/W	Grn
Off		
On	●	●

NEUTRAL LIGHT CIRCUIT OPERATION

Power is supplied to the transmission switch from the Red/White wire when the key and engine stop switch are on. When neutral is selected, power flows through the switch to the Green/White wire, through the lamp and to ground via the Brown wire.

If the light is not on when neutral is selected, check the bulb. If the bulb is good, check the wiring, transmission switches, and lamp socket ground path.

BRAKE LIGHT SWITCH

1. Remove front cover.
2. Disconnect wire harness from switch.
3. Connect an ohmmeter across switch contacts. Reading should be infinite (∞).
4. Apply brake at handlebar lever and check for continuity between switch contacts. Replace switch if there is no continuity or greater than .5 ohms resistance when the brake is applied with slight pressure.

NOTES



STARTER SYSTEM TESTING

Condition: Starter fails to turn motor. **NOTE:** Make sure engine crankshaft is free to turn before proceeding with dynamic testing of starter system. A digital multimeter must be used for this test.

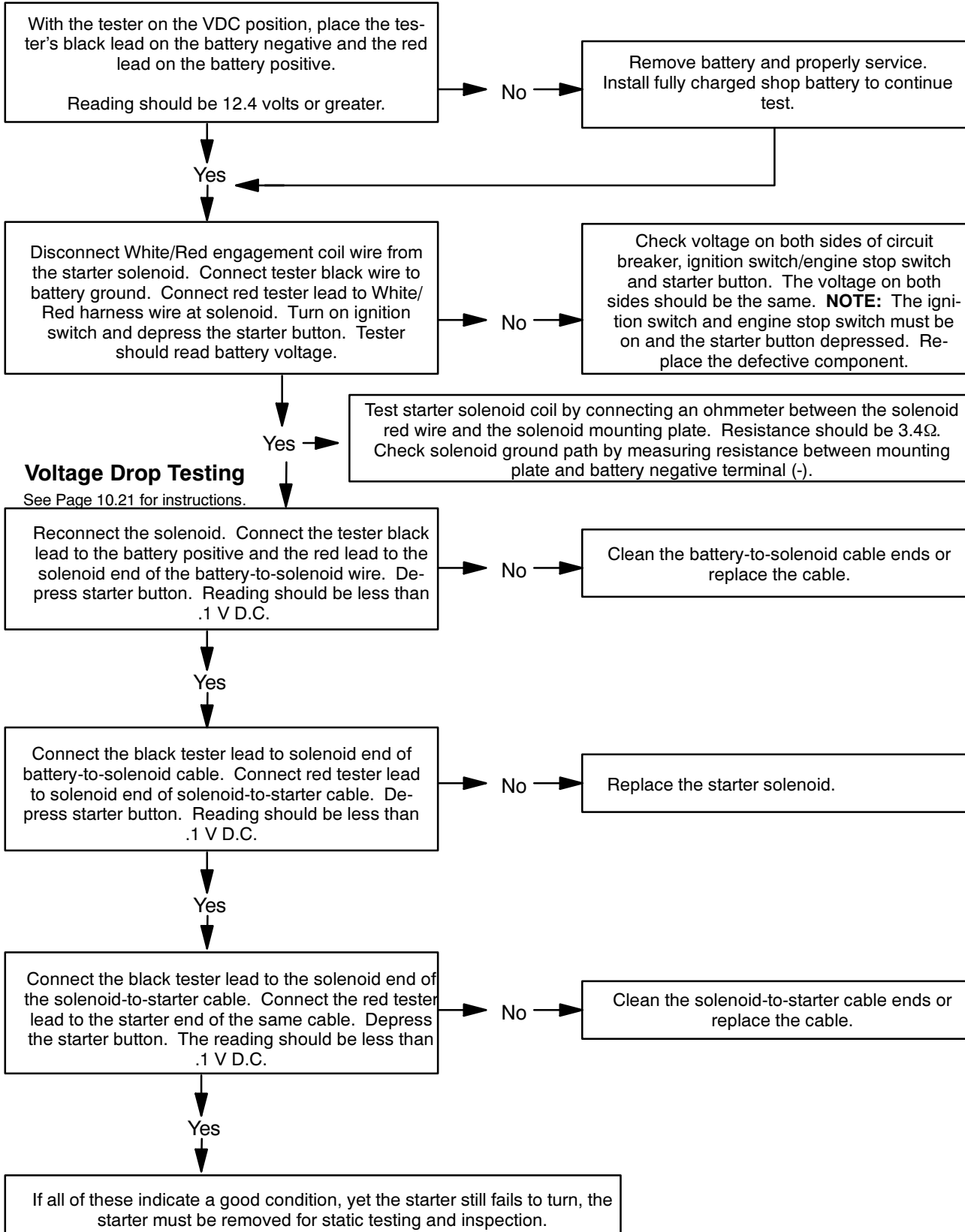



STARTER SYSTEM **TROUBLESHOOTING**

Starter Motor Does Not Turn

- Battery discharged - low specific gravity
- Loose or faulty battery cables or corroded connections (see Voltage Drop Tests)
- Related wiring loose, disconnected, or corroded
- Poor ground connections at battery cable, starter motor or starter solenoid (see Voltage Drop Tests)
- Faulty starter button
- Faulty ignition switch (Do other systems function?)
- Faulty starter solenoid or starter motor.
- Engine problem - seized or binding (Can engine be rotated easily with recoil starter?)

Starter Motor Turns Over Slowly

- Battery discharged - low specific gravity
- Excessive circuit resistance - poor connections (see Voltage Drop Test below)
- Engine problem - seized or binding (Can engine be rotated easily with recoil starter?)
- Faulty or worn brushes in starter motor
- Automatic compression release inoperative

Starter Motor Turns - Engine Does Not Rotate

- Faulty starter drive
- Faulty starter drive gears or starter motor gear
- Faulty flywheel gear or loose flywheel

VOLTAGE DROP TEST

The Voltage Drop Test is used to test for bad connections. When performing the test, you are testing the amount of voltage drop through the connection. A poor or corroded connection will appear as a high voltage reading. Voltage shown on the meter when testing connections should not exceed .1 VDC per connection or component.

To perform the test, place the meter on DC volts and place the meter leads across the connection to be tested. Refer to the chart on next page to perform

voltage drop tests on the starter system.

**Voltage should not exceed:
1 DC volts per connection**

STARTER MOTOR **DISASSEMBLY**

NOTE: Use electrical contact cleaner to clean starter motor parts. Some solvents may leave a residue or damage internal parts and insulation.



1. Note the alignment marks on both ends of the starter motor casing. These marks must align during reassembly.

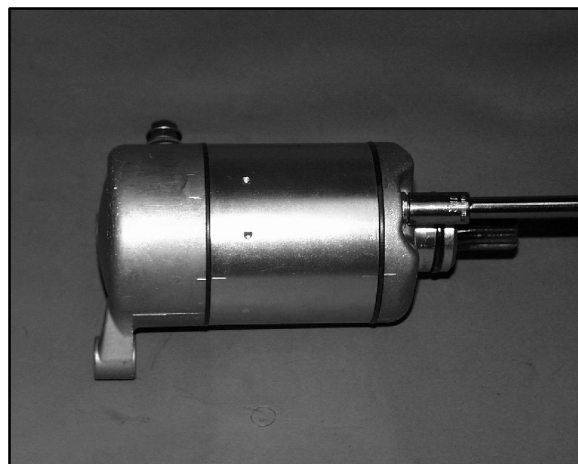

2. Remove the two bolts, washers, and sealing O-Rings. Inspect O-Rings and replace if damaged.

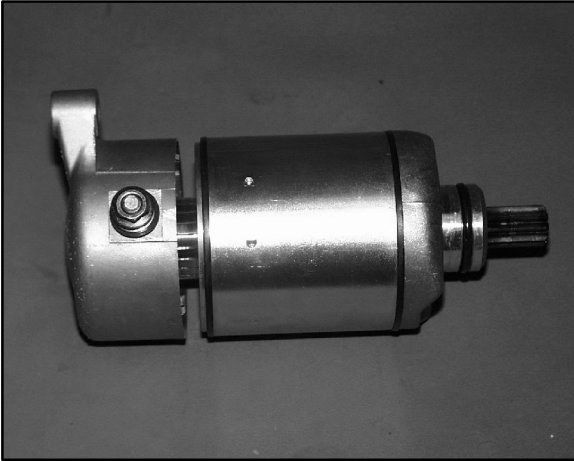

3. Remove brush terminal end of housing while holding other two sections together.

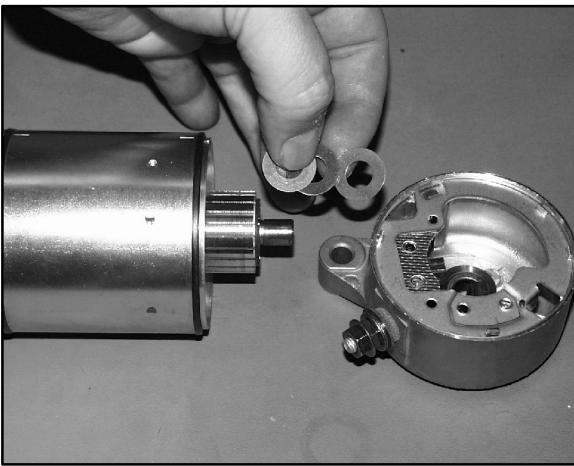

4. Remove shims from armature shaft. **NOTE:** All shims must be replaced during reassembly.

BRUSH INSPECTION/REPLACEMENT

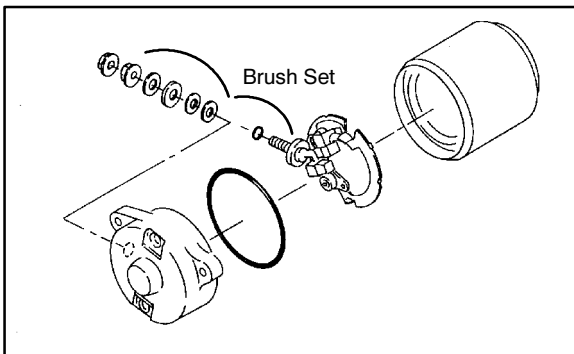

1. Using a digital multimeter, measure the resistance between the cable terminal and the insulated brush. The reading should be .3 ohms or less. Measure the resistance between the

cable terminal and brush housing. Make sure the brush is not touching the case. The reading should be infinite.

2. Remove nut, flat washer, large phenolic washer, two small phenolic washers, and O-Ring from brush terminal. Inspect the O-Ring and replace if damaged.

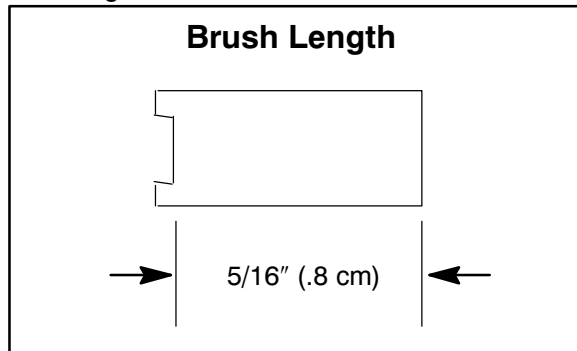

**Brush Length Service Limit:
5/16" (.8 cm)**

3. Remove brush plate and brushes. Measure length of brushes and replace if worn past the service limit. Replace springs if they are discolored or have inadequate tension.
4. Inspect surface of commutator for wear or discoloration. See Steps 3-6 of armature testing on Page 10.23.
5. Install a new carbon brush assembly in the brush housing. **NOTE:** Be sure that the terminal bolt insulating washer is properly seated in the housing, and the tab on the brush plate engages the notch in the brush plate housing.
6. Place a wrap of electrical tape on the threads of the terminal bolt to prevent O-Ring damage during reinstallation.
7. Install the O-Ring over the bolt. Make sure the O-ring is fully seated.

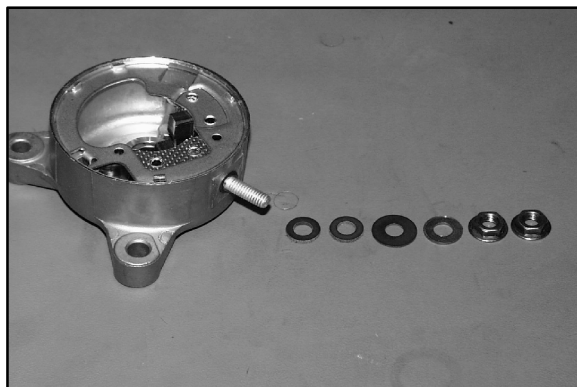

8. Remove the electrical tape and reinstall the two small phenolic washers, the large phenolic washer, flat washer, and nut.

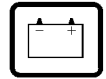

ARMATURE TESTING

1. Remove armature from starter casing. Note order of shims on drive end for reassembly.
2. Inspect surface of commutator. Replace if excessively worn or damaged.

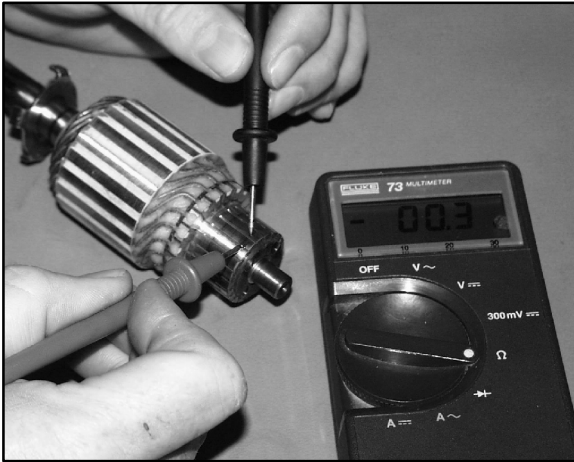

3. Using a digital multimeter, measure the resistance between each of the commutator segments. The reading should be .3 ohms or less.

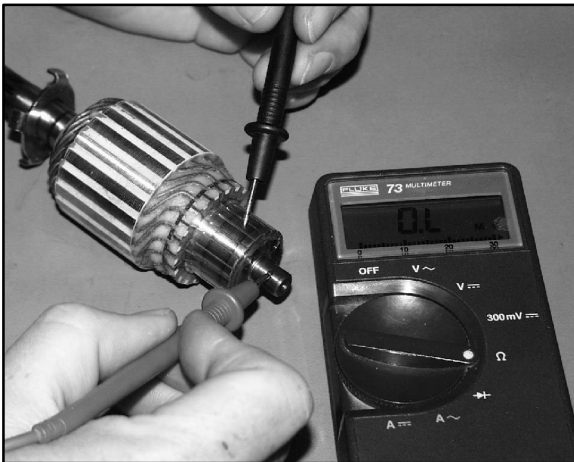

4. Measure the resistance between each commutator segment and the armature shaft. The reading should be infinite (no continuity).
5. Check commutator bars for discoloration. Bars discolored in pairs indicate shorted coils, requiring replacement of the starter motor.
6. Place armature in a growler. Turn growler on and position a hacksaw blade or feeler gauge lengthwise 1/8" (.3 cm) above armature coil laminates. Rotate armature 360°. If hacksaw blade is drawn to armature on any pole, the armature is shorted and must be replaced.

STARTER ASSEMBLY



1. Place armature in field magnet casing.
2. Place shims on drive end of armature shaft with phenolic washer outermost on shaft. Engage tabs of stationary washer in drive end housing, holding it in place with a light film of grease.
3. Install case sealing O-Ring. Make sure O-Ring is in good condition and not twisted on the case. Lubricate needle bearing and oil seal with a light film of grease, and install housing, aligning marks.
4. Install O-Ring on other end of field magnet casing. Make sure it is in good condition and not twisted on the case.
5. Align casing marks and install housing, pushing back brushes while installing shaft in bushing.
6. Reinstall starter motor housing bolts. Make sure O-Rings are in good condition and seated in groove.
7. Inspect permanent magnets in starter housing. Make sure they are not cracked or separated from housing.

CAUTION: Use care when handling starter housing. Do not drop or strike the housing as magnet damage is possible. If magnets are damaged, starter must be replaced.



STARTER DRIVE

Pinion Gear - Anti Kick-out Shoe, Garter Spring Replacement

If the garter spring is damaged, the overrun clutch may fail to return properly. The replacement spring is (PN 7042039). Use either of the following methods to remove and install a new garter spring.

in the reverse order. Make sure the end washer is positioned properly so that it will hold the lock ring in its groove.

Polaris Premium Starter Drive Grease
(PN 2871460)

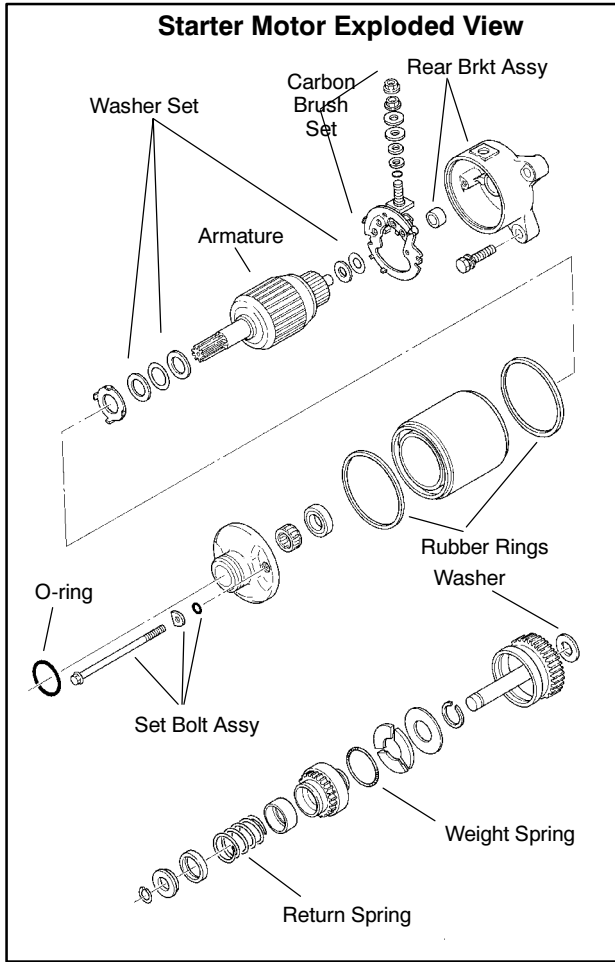

NOTES

1. Screw the overrun clutch out to the engaged position on the pinion shaft assembly. Use a small piece of wire with the end bent in a hook and pick the old spring out of its channel. Slide it off the end of the shaft. Slide the new spring over the overrun clutch and into the spring groove. Make sure that the spring is positioned between the shoe alignment pins and the back flange of the anti kick-out shoes.
2. Remove the lock ring, end washer, spring retainers and clutch return spring. Screw the overrun clutch off the end of the pinion shaft. Remove the old spring and install a new one. Lightly grease the pinion shaft and reinstall the clutch, spring, retainers, end washer and lock ring

A

A-Arm Replacement, 5.6
Air Filter Cleaning, 2.15
Air Filter Service, 2.15
Alternator Output Test, 10.13
Alternator, Exploded View, 10.9

B

Battery Charging, 10.16
Battery Installation, 10.15
Battery Maintenance, 2.13
Battery Service, 10.14, 10.16
Battery Terminal Bolts, 10.14
Battery Testing, 10.15
Battery, Off Season Storage, 10.16
Body Assembly Exploded View, 5.2
Brake Bleeding, 9.6
Brake Bleeding/Fluid Change, 9.11
Brake Caliper Assembly, Rear, 9.19
Brake Caliper Disassembly, Front, 9.12
Brake Caliper Exploded View, Front, 9.16
Brake Caliper Exploded View, Rear, 9.22
Brake Caliper Inspection, Front, 9.13
Brake Caliper Installation, Front, 9.15
Brake Caliper Removal, Front, 9.12
Brake Caliper Removal, Rear, 9.18
Brake Disc Inspection, Front, 9.11
Brake Disc Inspection, Rear, 9.20
Brake Disc Removal/Replacement, Front, 9.11
Brake Fluid Change, 9.6
Brake Fluid Level, 2.23
Brake Hose/Fitting Inspection, 2.23
Brake Light Switch Testing, 10.19
Brake Noise, 9.3
Brake Pad Application, 9.3
Brake Pad Assembly, Front, 9.10
Brake Pad Inspection, 2.23
Brake Pad Installation, Rear, 9.17

Brake Pad Removal, Front, 9.9
Brake Pad Removal, Rear, 9.17
Brake System Inspection, 2.23
Brake System Main Components, 9.5
Brake System Operation, 9.4
Brake System Service Notes, 9.3
Brake, Auxiliary, Hydraulic, 2.23
Brakelight Lamp Replacement, 10.18

C

Cam Chain Drive Sprocket Installation, 3.34
Cam Chain Tensioner Inspection, 3.11
Cam Chain Tensioner Installation, 3.41
Cam Chain Tensioner Removal, 3.11
Cam Chain/Camshaft Installation, 3.37
Cam Chain/Tensioner Blade, 3.27
Camber & Caster, 2.21
Camshaft Inspection, 3.14
Camshaft Removal, 3.13, 3.14
Camshaft Timing, 3.37, 3.38, 3.39, 3.40
Carburetor Assembly, 4.10
Carburetor Disassembly, 4.8
Carburetor Exploded View, BST34, 4.2
Carburetor Float Bowl Draining, 2.12
Carburetor Float Height Adjustment, 4.11
Carburetor Float System, 4.8
Carburetor Fuel Level Testing, 4.12
Carburetor Inspection, 4.9, 4.10
Carburetor Main System, 4.8
Carburetor Needle and Seat Testing, 4.11
Carburetor Operation, 4.6
Carburetor Pilot System, 4.7
Carburetor Starter System, 4.7
Carburetor System Function, 4.6
CDI Output Test, 10.11
Charging System Break Even Test, 10.13
Charging System Testing, 10.12, 10.13
Choke Adjustment, 2.10
Clutch Alignment, 6.15

Clutch Offset, 6.16
Combustion Chamber, 3.18
Compression Release Installation, 3.14
Compression Release Removal/Inspection, 3.14
Compression Test, 2.13
Concentric Swing Arm Installation, 5.8
Concentric Swing Arm Removal, 5.7
Connecting Rod Bearing Clearance Inspection, 3.31
Connecting Rod Bearing Inspection, 3.31
Connecting Rod Installation, 3.33
Controls Inspection, 2.27
Conversion Table, 1.10
Cover/Panel Removal, 5.5
Crankcase Assembly, 3.34
Crankcase Bearing Inspection, 3.31
Crankcase Bearing Installation, 3.32
Crankcase Disassembly, 3.25
Crankcase Inspection, 3.32
Crankcase Oil Strainer Inspection, 3.34
Crankcase Separation, 3.29
Cranking Output Test, 10.11
Crankshaft Bearing Inspection, 3.31
Crankshaft End Play Adjustment, 3.32
Crankshaft End Play Inspection, 3.32
Crankshaft Inspection, 3.30
Crankshaft Installation, 3.34
Crankshaft Removal/Inspection, 3.29
Cylinder Head Assembly, 3.21, 3.22
Cylinder Head Disassembly, 3.16
Cylinder Head Inspection, 3.15
Cylinder Head Installation, 3.36
Cylinder Head Reconditioning, 3.18
Cylinder Head Removal, 3.15
Cylinder Head Warpage, 3.16
Cylinder Honing, 3.6
Cylinder Inspection, 3.23, 3.24
Cylinder Installation, 3.36
Cylinder Removal, 3.22

D

Decal Replacement, 5.12
Decimal Equivalents, 1.9
Draining Recoil Housing, 2.16
Drive Belt Removal/Inspection, 6.14
Drive Belt Tension, 6.13
Drive Chain Adjustment, 2.24
Drive Chain Inspection, 2.24
Drive Clutch Assembly, 6.12
Drive Clutch Bushing Service, 6.16, 6.17, 6.18
Drive Clutch Disassembly, 6.10, 6.11, 6.12
Drive Clutch Exploded View, 6.7
Drive Clutch Inspection, 6.10
Drive Clutch Operation, 6.2
Drive Sprocket Removal/Inspection, 3.27
Driven Clutch Assembly, 6.20
Driven Clutch Bushing Service, 6.21, 6.22
Driven Clutch Disassembly, 6.19
Driven Clutch Operation, 6.2, 6.3
Dual Hydraulic Caliper Bleeding, 9.5

E

Electrical Service Notes, 10.2
Engine Accessible Components, 3.5
Engine Assembly, 3.32, 3.33, 3.34, 3.35, 3.36, 3.37, 3.38, 3.39, 3.40, 3.41, 3.42
Engine Bottom End Disassembly, 3.22, 3.23, 3.24, 3.25, 3.26, 3.27, 3.28, 3.29, 3.31
Engine Break in Period, 3.6
Engine Designation Numbers, 1.2
Engine Exploded View , ES32PF, 3.10
Engine Installation Notes, 3.6
Engine Lubrication, 3.7
Engine Mounts, 2.13
Engine Oil Check, 2.17
Engine Removal, 3.5
Engine Serial Number Location, 1.2
Engine Service Data, 3.2, 3.3
Engine to Frame Ground, 2.15

Engine Top End Disassembly, 3.11, 3.12, 3.13,
3.14, 3.15, 3.16, 3.17

ETC Switch Adjustment, 2.11

ETC Switch Testing, 10.7

Exhaust System, Maintenance, 2.22

Exhaust Valve Adjustment, 2.19

F

Fan Control Circuit, 10.6

Fan Motor Current Draw Test, 10.6

Fastener Torque, 2.13

Flywheel Identification, 10.8

Flywheel Installation, 3.42

Flywheel Removal/Inspection, 3.26

Frame, Nuts, Bolts, Fasteners, 2.28

Front Hub Assembly, 7.3

Front Hub Disassembly, 7.2

Front Hub Exploded View, 7.5

Front Hub Installation, 7.4

Front Strut Assembly, AWD, 5.9

Front Strut Ball Joint Replacement, 5.10

Front Strut Weldment Replacement, 5.10

Fuel Filter Maintenance, 2.12

Fuel Pump Exploded View, 4.3

Fuel Pump Service, 4.12

Fuel System, 2.12

Fuel Tank Assembly, Exploded View, 4.4

G

Gear Position Switch Test, 10.3

Glossary of Terms, 1.11

H

Headlamp Replacement, 10.18

Headlamp Switch Testing, 10.19

Headlight Adjustment , 10.17

Headlight Assembly Removal, 10.17

Headlight Lamp Replacement, 10.17

Honing to Oversize, 3.6, 3.7

I

Idle Speed Adjustment, 2.11

Ignition System Testing, 10.10

Ignition Timing, 2.14

Indicator Lamp Replacement, 10.18

Intake Valve Adjustment, 2.19

J

Jetting Guidelines, 4.5

K

Keys, Replacement, 1.4

L

Load Test, 10.16

Lubricants, 2.4

Lubricants, Recommended, 2.5

Lubrication Chart, 2.6

Lubrication Charts, 2.5

Lubrication, Transmission, 2.8, 8.2

M

Machine Dimensions, 1.5

Maintenance Chart, Periodic, 2.2, 2.3

Master Cylinder Disassembly, 9.7

Master Cylinder Installation, 9.8

Model & Serial Number Location, 1.2

Model Identification, 1.2

Model Specifications, 1.6, 1.7

N

Neutral Light Testing, 10.19

O

Oil & Filter Change–Magnum 500, 2.18

Oil Cooler Assembly, 3.8
Oil Filter Installation, 3.35
Oil Flow, ES32PF, 3.9
Oil Pressure Test, 3.7
Oil Pump Assembly, 3.29
Oil Pump Installation, 3.34
Oil Pump Removal/Inspection, 3.28

P

Paint Codes, 1.8
Pilot Screw Adjustment, 2.10
Piston Identification, 3.5
Piston Inspection, 3.24
Piston Installation, 3.35
Piston Removal, 3.23
Piston Ring Installation, 3.35
Piston Ring Installed Gap, 3.25
Pod Assembly Removal, 10.18
Pre Ride Inspection, 2.3
Pressure Relief Valve, 3.28
Pressure Relief Valve Installation, 3.34
Publication Numbers, 1.8
PVT Assembly, 6.6
PVT Disassembly, 6.5
PVT Drying, 2.17, 6.3
PVT Maintenance, 6.3
PVT Operation, 6.2
PVT Overheating, 6.4
PVT System Sealing/Ducting Components, 6.7
PVT Troubleshooting, 6.23, 6.24

R

Rear Axle Assembly, 7.7
Rear Axle Assembly, Exploded View, 7.9
Rear Axle Disassembly, 7.7
Rear Axle Installation, 7.8
Rear Axle Removal, 7.6

Rear Housing Bearing Service, 7.10
Rear Housing Installation, 7.11
Rear Housing Removal, 7.10
Recoil Assembly, 3.44
Recoil Disassembly/Inspection, 3.42
Recoil Draining, 2.16
Reverse Limit System, 10.4, 10.5
Rocker Arm/Shaft Inspection, 3.12
Rocker Shaft/Rocker Arm Assembly Installation, 3.42
Troubleshooting, Transmission, 8.7

S

Sediment Tube, Maintenance, 2.16
Shift Linkage Adjustment, 2.9
Shift Weights, 6.9
Side Panel Removal, 5.5
Spark Plug Maintenance, 2.14
Special Tools, 2.7, 3.4, 4.5, 6.2, 8.2, 9.3, 10.2
Specific Gravity Test, 10.16
Specifications, Brake, 9.2
Specifications, Drive Clutch Spring, 6.8
Specifications, Speed Limiter, 10.3
Specifications, Torque, Brakes, 9.2
Specifications, Torque, Engine, 3.4
Specifications, Torque, Final Drive, 7.2
Specifications, Torque, PVT, 6.2
Specifications, Torque, Standard, 1.8
Specifications, Torque, Suspension, 5.4
Specifications, Torque, Transmission, 8.2
Spider Removal, 6.11
Sprocket Inspection, 2.24
Starter Assembly, 10.23
Starter Disassembly, 10.21
Starter Drive, 10.24
Starter Drive Installation, 3.42
Starter Drive Removal/Inspection, 3.26
Starter Motor Armature Testing, 10.23
Starter Motor Brush Inspection/Replacement, 10.22

Starter System Test, 10.20
Stator Installation, 3.41
Stator Removal/Inspection, 3.26
Steering Assembly, Exploded View, 4x4, 5.3
Steering Maintenance, 2.20
Steering Post Assembly, 5.12
Suspension Preload Adjustment, 2.26
Suspension Special Tools, 5.4
Suspension, Front, Inspection, 2.26
Suspension, Rear, Inspection, 2.26

T

Taillight Lamp Replacement, 10.18
Tap Drill Chart, 1.9
Tensioner Blade Installation, 3.35
Thermistor Testing, 10.6
Throttle Cable Adjustment, 2.11
Throttle Operation, 2.10, 2.11
Tie Rod Inspection, 2.20
Timing Check Procedures, 10.2
Tire Inspection, 2.28
Tire Pressure, 2.28
Tire Tread Depth, 2.28
Toe Alignment, 2.21, 2.22
Torque Patterns, Engine, 3.4
Torque Stop Adjustment, 2.8
Trailboss, 2003, Model, 1.3
Transmission Assembly, 8.5
Transmission Disassembly, 8.2

Transmission Exploded View, 8.7, 8.8
Transmission I.D. Location, 1.2
Transmission Installation, 8.2
Transmission Linkage Adjustment, 2.9
Transmission Removal, 8.2
Troubleshooting, Brakes, 9.21
Troubleshooting, Engine, 3.45, 3.46
Troubleshooting, Fuel System/Carb, 4.13
Troubleshooting, Ignition System, 10.11
Troubleshooting, Spark Plug, 3.45
Troubleshooting, Starter System, 10.21

V

Valve Clearance, 2.19
Valve Guide Removal/Installation, 3.18
Valve Inspection, 3.17
Valve Seal Testing, 3.22
Valve Seat Inspection, 3.18
Valve Seat Reconditioning, 3.18, 3.19, 3.20
VIN Identification, 1.2
Voltage Drop Test, 10.21
Voltage Test Open Circuit, 10.15

W

Wheel Inspection, 2.27
Wheel Installation, 2.27
Wheel Removal Front or Rear, 2.27
Wiring Diagram, 2002, Trail Boss 325, 10.29

2003 TRAILBOSS 330

WIRES ARE REPRESENTED BY SOLID OR DASHED LINES TO SIMPLIFY TRACING IN DIAGRAM.

COLOR CODE:

- BLK = BLACK
- BRN = BROWN
- GRN = GREEN
- PUR = PURPLE
- BLU = BLUE
- GRY = GRAY
- OR = ORANGE
- Y = YELLOW
- R = RED
- W = WHITE



TWO COLOR WIRES ARE SHOWN WITH MAIN/TRACE COLORS. EXAMPLE: R/Y = RED WITH YELLOW TRACER.
 NC = SWITCH NORMALLY CLOSED
 NO = SWITCH NORMALLY OPEN

THERMISTOR RESISTANCE		SOLID STATE RELAY OUTPUTS	
°F	°C	OHMS (±3%)	
77	25	100,000	
240	116	3466	FAN OFF (TEMP FALLING)
260	127	2519	FAN ON (TEMP RISING)
290	143	1607	HOT LIGHT ON/OFF

BOTH LAMP AND FAN SHOULD BE ON WITH THERMISTOR LEADS SHORTED TO EACH OTHER.

SPLICE LOCATED IN HARNESS BETWEEN EXITS TO		
RED/WHITE	GROUND	ALTERNATOR
YELLOW	LEFT HANDLEBAR CONTROL	RIGHT HANDLEBAR CONTROL
GREEN	LEFT HANDLEBAR CONTROL	RIGHT HANDLEBAR CONTROL

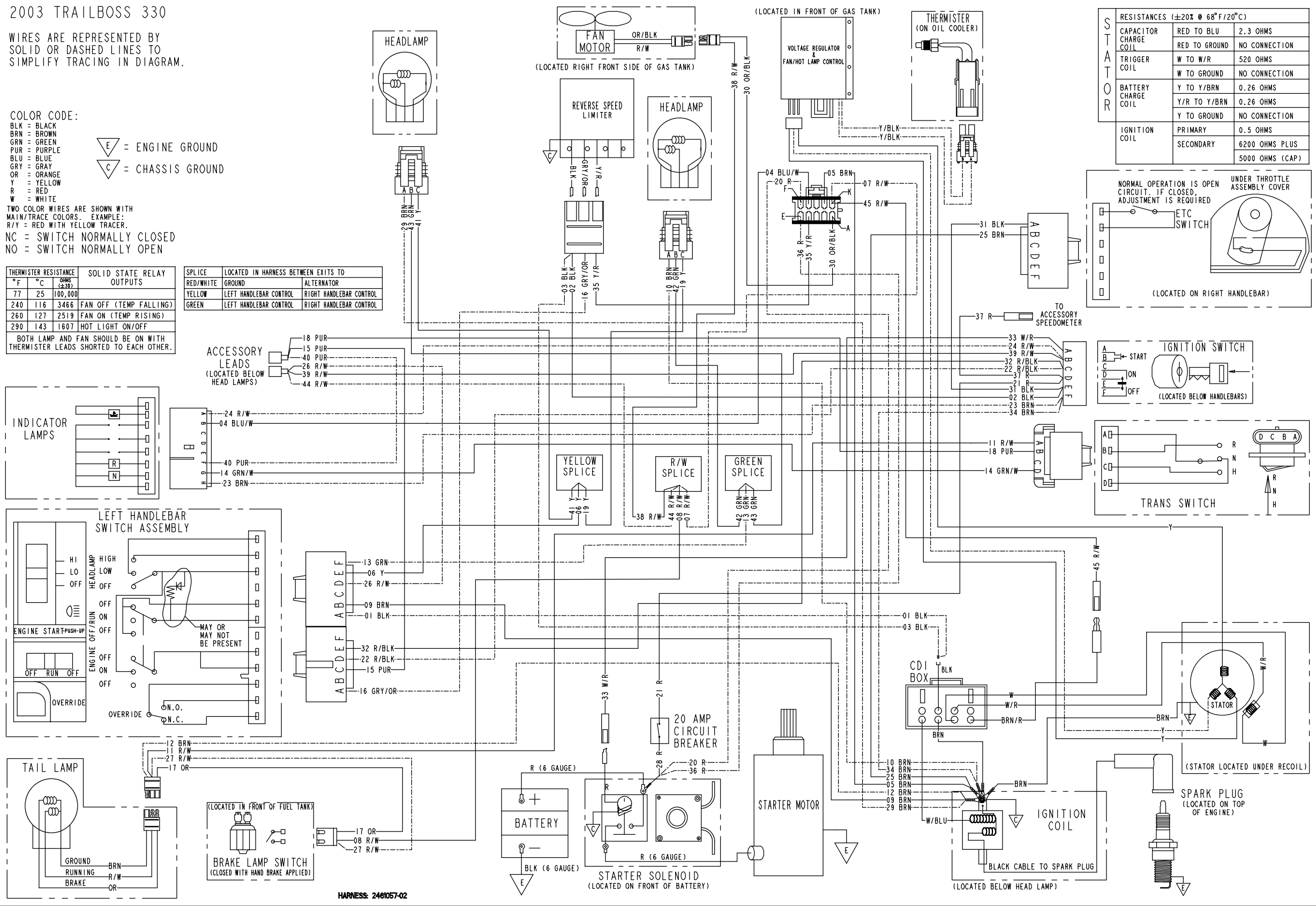

RESISTANCES (±20% @ 68°F/20°C)		
CAPACITOR CHARGE COIL	RED TO BLU	2.3 OHMS
	RED TO GROUND	NO CONNECTION
TRIGGER COIL	W TO W/R	520 OHMS
	W TO GROUND	NO CONNECTION
BATTERY CHARGE COIL	Y TO Y/BRN	0.26 OHMS
	Y/R TO Y/BRN	0.26 OHMS
	Y TO GROUND	NO CONNECTION
IGNITION COIL	PRIMARY	0.5 OHMS
	SECONDARY	6200 OHMS PLUS 5000 OHMS (CAP)

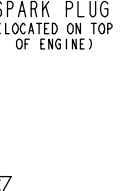
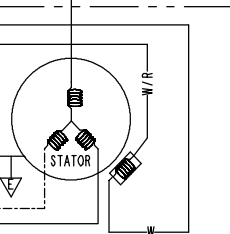
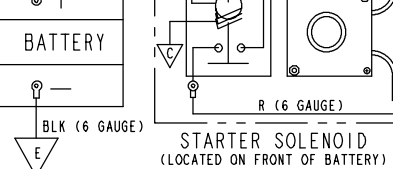
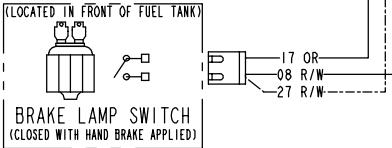
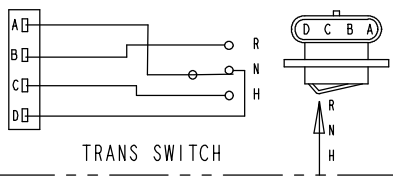
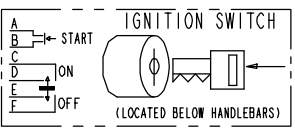
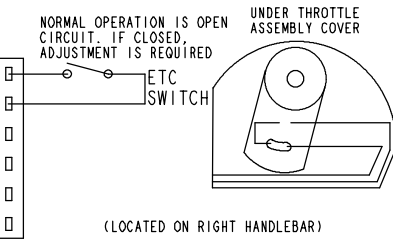

HARNESS: 2461057-02

