



Harley-Davidson Motor Company

# 2015 Boom! Box Owner's Manual

99464-15



Information Provided by:

**DEALER**  
E-PROCESS



# REGULATORY AND SAFETY INFORMATION

## Exposure to Radio Frequency Radiation

The radiated output power of the internal wireless radio is far below the FCC radio frequency exposure limits. Nevertheless, the wireless radio shall be used in such a manner that the radio is 20 cm or further from the human body.

The internal wireless radio operates within guidelines found in radio frequency safety standards and recommendations, which reflect the consensus of the scientific community.

The radio manufacturer believes the internal wireless radio is safe for use by consumers. The level of energy emitted is far less than the electromagnetic energy emitted by wireless devices such as mobile phones. However, the use of wireless radios may be restricted in some situations or environments, such as aboard airplanes. If you are unsure of restrictions, you are encouraged to ask for authorization before turning on the wireless radio.

This device complies with Part 15 of the FCC Rules and with Industry Canada license-exempt RSS standard(s). Operation is subject to the following two conditions: (1) this device may not cause harmful interference, and (2) this device must accept any interference received, including interference that may cause undesired operation.

Le présent appareil est conforme aux CNR d'Industrie Canada applicables aux appareils radio exempts de licence. L'exploitation est autorisée aux deux conditions suivantes: (1) l'appareil ne doit pas produire de brouillage, et (2) l'utilisateur de l'appareil doit accepter tout brouillage radioélectrique subi, même si le brouillage est susceptible d'en compromettre le fonctionnement.

**NOTE:** This equipment has been tested and found to comply with the limits for a Class B digital device, pursuant to Part 15 of the FCC Rules. These limits are designed to provide reasonable protection against harmful interference in a residential installation. This equipment generates, uses and can radiate radio frequency energy and, if not installed and used in accordance with the instructions, may cause harmful interference to radio communications. However, there is no guarantee that interference will not occur in a particular installation

If this equipment does cause harmful interference to radio or television reception, which can be determined by turning the equipment off and on, the user is encouraged to try to correct the interference by one or more of the following measures: (a) Increase the separation between the equipment and receiver. (b) Consult the dealer or an experienced radio technician for help.



## DECLARATION OF CONFORMITY

The EC Declaration of Conformity is available at [www.harman.com/EN-US/ContactUs/Pages/Compliance.aspx](http://www.harman.com/EN-US/ContactUs/Pages/Compliance.aspx).

English

Hereby, Harman Becker Automotive Systems, Inc., declares that this device is in compliance with the essential requirements and other relevant provisions of Directive 1999/5/EC.

Česky [Czech]

Harman Becker Automotive Systems, Inc. tímto prohlašuje, že toto zařízení je ve shodě se základními požadavky a dalšími příslušnými ustanoveními směrnice 1999/5/ES.

Dansk [Danish]

Undertegnede Harman Becker Automotive Systems, Inc. erklærer herved, at følgende udstyr anordning overholder de væsentlige krav og øvrige relevante krav i direktiv 1999/5/EF.

Deutsch [German]

Hiermit erklärt Harman Becker Automotive Systems, Inc., dass sich das Gerät in Übereinstimmung mit den grundlegenden Anforderungen und den übrigen einschlägigen Bestimmungen der Richtlinie 1999/5/EG befindet.

Eesti [Estonian]

Käesolevaga kinnitab Harman Becker Automotive Systems, Inc. et käesolev seade vastab direktiivi 1999/5/EÜ põhinõuetele ja teistele asjakohastele sätetele.

Español [Spanish]

Por medio de la presente Harman Becker Automotive Systems, Inc. declara que el dispositivo cumple con los requisitos esenciales y cualesquiera otras disposiciones aplicables o exigibles de la Directiva 1999/5/CE.

Ελληνική [Greek]

ΜΕ ΤΗΝ ΠΑΡΟΥΣΑ Harman Becker Automotive Systems, Inc. ΔΗΛΩΝΕΙ ΟΤΙ Η ΣΥΣΚΕΥΗ ΣΥΜΜΟΡΦΩΝΕΤΑΙ ΠΡΟΣ ΤΙΣ ΟΥΣΙΩΔΕΙΣ ΑΠΑΙΤΗΣΕΙΣ ΚΑΙ ΤΙΣ ΛΟΙΠΕΣ ΣΧΕΤΙΚΕΣ ΔΙΑΤΑΞΕΙΣ ΤΗΣ ΟΔΗΓΙΑΣ 1999/5/ΕΚ.

Français [French]

Par la présente Harman Becker Automotive Systems, Inc. déclare que ce dispositif est conforme aux exigences essentielles et aux autres dispositions pertinentes de la directive 1999/5/CE.

Italiano [Italian]

Con la presente Harman Becker Automotive Systems, Inc. dichiara che questo dispositivo è conforme ai requisiti essenziali ed alle altre disposizioni pertinenti stabilite dalla direttiva 1999/5/CE.

Latviski [Latvian]

Ar šo Harman Becker Automotive Systems, Inc. deklarē, ka ierīce atbilst Direktīvas 1999/5/EK būtiskajām prasībām un citiem ar to saistītajiem noteikumiem.

Lietuvių [Lithuanian]

Šiuo Harman Becker Automotive Systems, Inc. deklaruoja, kad šis įrenginys atitinka esminius reikalavimus ir kitas 1999/5/EB Direktyvos nuostatas.

Nederlands [Dutch]

Hierbij verklaart Harman Becker Automotive Systems, Inc. dat het toestel in overeenstemming is met de essentiële eisen en de andere relevante bepalingen van richtlijn 1999/5/EG.

Malti [Maltese]

Hawnhekk, Harman Becker Automotive Systems, Inc., tiddikjara li dan il-prodott jikkonforma mar-rekwiżiti essenzjali u ma' dispożizzjonijiet oħrajn rilevanti li hemm fid-Direttiva 1999/5/KE.

Magyar [Hungarian]

Alulírott, Harman Becker Automotive Systems, Inc. nyilatkozom, hogy a készülék megfelel a vonatkozó alapvető követelményeknek és az 1999/5/EC irányelv egyéb előírásainak.

Polski [Polish]

Niniejszym Harman Becker Automotive Systems, Inc. oświadcza, że urządzenie jest zgodne z zasadniczymi wymogami oraz pozostałymi stosownymi postanowieniami Dyrektywy 1999/5/WE.

Português [Portuguese]

Harman Becker Automotive Systems, Inc. declara que este dispositivo está conforme com os requisitos essenciais e outras disposições da Directiva 1999/5/CE.

Slovensko [Slovenian]

Harman Becker Automotive Systems, Inc. izjavlja, da je ta izdelek v skladu z bistvenimi zahtevami in ostalimi relevantnimi določili direktive 1999/5/ES.

Slovensky [Slovak]

Harman Becker Automotive Systems, Inc. týmto vyhlasuje, že zariadenie spĺňa základné požiadavky a všetky príslušné ustanovenia Smernice 1999/5/ES.

Suomi [Finnish]

Harman Becker Automotive Systems, Inc. vakuuttaa täten, että tämä laite on direktiivin 1999/5/EY oleellisten vaatimusten ja sitä koskevien direktiivin muiden ehtojen mukainen.

Svenska [Swedish]

Härmed intygar Harman Becker Automotive Systems, Inc. att denna apparat står i överensstämmelse med de väsentliga egenskapskrav och övriga relevanta bestämmelser som framgår av direktiv 1999/5/EG.

Íslenska [Icelandic]

Hér með lýsir Harman Becker Automotive Systems, Inc. yfir því að tæki þetta er í samræmi við grunnkröfur og aðrar kröfur, sem gerðar eru í tilskipun 1999/5/EC.

Norsk [Norwegian]

Harman Becker Automotive Systems, Inc. erklærer herved at denne enheten er i samsvar med de grunnleggende krav og øvrige relevante krav i direktiv 1999/5/EF.

## MÉXICO COFETEL AVISO

La operación de este equipo está sujeta a las siguientes dos condiciones: (1) es posible que este equipo o dispositivo no cause interferencia perjudicial y (2) este equipo o dispositivo debe aceptar cualquier interferencia, incluyendo la que pueda causar su operación no deseada.

## BRASIL ANATEL NOTICE

- Este produto está homologado pela ANATEL, de acordo com os procedimentos regulamentados pela Resolução 242/2000, e atende aos requisitos técnicos aplicados.
- Este equipamento opera em caráter secundário, isto é, não tem direito a proteção contra interferência prejudicial, mesmo de estações do mesmo tipo, e não pode causar interferência a sistemas operando em caráter primário.
- Para maiores informações, consulte o site da ANATEL [www.anatel.gov.br](http://www.anatel.gov.br).

## 低功率電波輻射性電機管理辦法 (Taiwan)

1. 經型式認證合格之低功率射頻電機，非經許可，公司、商號或使用者均不得擅自變更頻率、加大功率或變更原設計之特性及功能。
2. 低功率射頻電機之使用不得影響飛航安全及干擾合法通信；經發現有干擾現象時，應立即停用，並改善至無干擾時方得繼續使用。  
前項合法通信，指依電信法規定作業之無線電通信。低功率射頻電機須忍受合法通信或工業、科學及醫療用電波輻射性電機設備之干擾。

## NOTES



# TABLE OF CONTENTS

## SAFETY FIRST

Safety Information.....	1
Navigation.....	3
Pre-Ride Checklist.....	3
Emergency Phone Number.....	4
Emergency CB Operation.....	4

## FEATURES AND SPECIFICATIONS

Features, Options and Specifications.....	5
---	---

## CONTROLS AND COMPONENTS

Infotainment Controls.....	17
POWER/MUTE Switch.....	18
HOME Switch.....	18
Favorite Switch (FAV).....	18
Navigation Switch (6.5 Only).....	19
Soft Keys (4.3 Only).....	19
Touchscreen (6.5 Only).....	20
Boom! Box Hand Controls.....	20
Left Hand Control Audio Functions.....	20
Right Hand Control Audio Functions.....	21
HOME/VOLUME/PREVIOUS/NEXT Switch.....	22
Voice Recognition Switch.....	23

Push-To-Talk/Squelch Switch.....	23
CURSOR/SELECT Switch.....	23
Vehicle Information Switch.....	23
Rear (Passenger) Controls.....	24
MODE/UP/DN Switch.....	24
Push-To-Talk (PTT)/Volume (VOL) Switch.....	24
Enabling Rear Controls.....	24
Headset Connectors.....	25
Microphone.....	27
Media Compartment (USB Port).....	28
Media Compartment (Fixed Fairing Vehicles).....	28
Media Compartment (Other Vehicles).....	29
USB Hub.....	29
Speakers.....	31
Fairing Speakers.....	31
Fairing Lower Speakers.....	31
Saddlebag Speakers.....	31
Tour-Pak Speakers (With Bass Boost Ports).....	32
Amplifier.....	32
Antennas and Reception.....	32
Bluetooth.....	33
Turning Motorcycle On, Off or to Accessory Mode.....	33
Disconnecting the Vehicle Battery.....	34

# TABLE OF CONTENTS

---

## BASIC OPERATION

Home Screen.....	35
Screen Menu Bar.....	36
Checkboxes.....	36
Multiselect Button.....	37
Scroll Controls.....	37
Keyboard.....	39
Smart Speller.....	41
Volume Controls.....	41
Popup Screens.....	42
Lockout Screens.....	42
Status Bar.....	42

## SYSTEM SETTINGS

System Setup.....	47
Setup Menu.....	47
Language.....	49
Screen Brightness.....	49
Button Brightness.....	50
Day/Night Colors Mode.....	50
Background Color (6.5 Only).....	51
English Units/Metric.....	51
Clock.....	52

Keyboard (6.5 Only).....	53
Speaker/Headset Selection.....	53
Audio Settings (Bass/Treble).....	54
Fade.....	54
Speed Volume.....	55
Feedback (Prompts).....	56
Rear Controls.....	57
Classic Mode.....	57
Global Presets.....	58
Bluetooth.....	60
Ring Tones.....	60
SiriusXM.....	60
Traffic.....	60
System Information.....	60
Software Update.....	61
Privacy Reset.....	63
Factory Restore.....	63

## FAVORITES

Favorites.....	65
Setting a Favorite.....	65
Selecting a Favorite.....	65

# TABLE OF CONTENTS

## TUNER

Tuner.....	67
Selecting a Band (Menu Buttons).....	68
Selecting a Band (HOME Hand Control, Classic Mode).....	68
Selecting a Band (Voice Recognition).....	68
Tune/Seek/Preset Settings.....	68
Tuning a Station (Hand Control Switch).....	69
Tuning a Station (Voice Recognition).....	69
Seeking a Station (Hand Control Switch).....	69
Seeking a Station (Voice Recognition).....	69
Scanning Stations.....	70
Presets.....	70
Categories (Cat).....	70
Selecting Categories.....	71
Station List.....	72
Weather Band.....	73
Weather Alert.....	74
RBDS/RDS.....	75
RDS Features.....	75

## MEDIA

Media Screen.....	77
Media Devices.....	78

Connecting Media Device (USB).....	79
Connecting Media Device (Bluetooth).....	80
Device Players and Applications (Bluetooth).....	80
Selecting Media Device.....	80
Play Previous/Next Media File (or Previous/Next Preset).....	81
Pause, Rewind, or Fast Forward Media File.....	81
Scanning Media Files.....	81
Repeat Current File.....	82
Play Random Files (Shuffle).....	82
Play Songs From Track List.....	82
Media Presets.....	83
Finding a Media File.....	83
Finding a Media File (Playlist).....	85
Finding a Media File (Artist, Album or Genre).....	85
Finding a Media File (Song Title).....	85
Finding a Media File (Podcast).....	86
Finding a Media File (Audio Book).....	87
Finding a Media File (Video, TV Show, Movie, Music Video).....	87
Selecting Media File (Using Voice Recognition).....	87
Saving Media File as Favorite.....	88
Saving Media File as Ring Tone.....	88

# TABLE OF CONTENTS

---

## BLUETOOTH

Enabling Bluetooth.....	89
Pairing a Bluetooth Device.....	89
Connecting/Disconnecting a Bluetooth Device.....	90
Reconnecting After Vehicle Turns On.....	91
Deleting a Paired Device.....	92

## PHONE

Phone Compatibility.....	93
Bluetooth and USB Connections For Phones.....	93
Phone Menu.....	93
Call Screen.....	94
Making a Call (Dialing).....	96
Making a Call (Phone Book Contact).....	97
Making a Call (Navigation POI).....	97
Making a Call (SiriusXM Gas Station).....	97
Making a Call (Emergency Phone Number).....	98
Making a Call (Dialing with Voice Recognition).....	98
Making a Call (Calling a Contact with Voice Recognition).....	98
Receiving a Call (Accepting/Ignoring).....	98
Receiving a Call (Radio Turned Off).....	99
Ending a Call.....	99

Adjusting Call Volume.....	99
Muting Call Audio.....	99
Routing Call Audio.....	99
Multiple Calls.....	100
Voice Mail.....	100
Phone Book.....	100
Setting Up Contacts in a Phone.....	101
Refresh Phone Book.....	101
Showing Contact Details.....	101
Viewing Saved Contacts and Phone Numbers.....	102
Saving a Phone Book Contact.....	102
Saving a Dialed Phone Number.....	102
Saving Phone Number from Current Call.....	102
Delete Saved Contact.....	103
Call History.....	103
Text Messaging.....	103
Enabling Text Message Service (SMS).....	104
Enabling Text Message Notification (Apple Devices).....	104
Text Message Auto-Reply.....	105
Viewing/Playing a Text Message.....	106
Selecting Ring Tone.....	106
Adding New Ring Tone (Media File Currently Playing).....	107
Adding New Ring Tone (Bluetooth Setup).....	107
Resuming Calls After Vehicle Shutdown.....	107

# TABLE OF CONTENTS

Transferring a Call Back to the Phone.....	108
Changing the Emergency Phone Number.....	108

## CITIZEN BAND (CB) RADIO

CB Radio.....	111
Turning CB On.....	111
Turning CB Off.....	112
Conflicting Transmissions.....	112
Emergency Operation (Channel 9).....	112
Transmitting on CB.....	113
Receiving CB Audio.....	113
Tuning CB Channels.....	114
CB Presets.....	114
Squelch.....	114
CB Volume.....	116
Passenger CB Operation.....	116
Factors Affecting CB Range.....	117
Adding an Optional CB Module.....	117

## INTERCOM

Intercom.....	119
Turning Intercom On/Off.....	120
Adjusting Microphone Sensitivity (VOX).....	121
Speed Volume.....	121

Adjusting Intercom Volume (Rider and Passenger Headsets).....	121
Operating Intercom (Voice Activation, VOX).....	122
Operating Intercom (PTT Switch).....	122

## SIRIUSXM

SiriusXM Satellite Radio.....	123
Optional SiriusXM Accessory.....	123
Trial Subscription.....	123
Check Subscription Status.....	123
Subscribing to SiriusXM.....	124
Listening to SiriusXM Radio.....	125
SiriusXM Presets.....	126
Selecting a Channel (Hand Controls).....	127
Selecting a Channel (Channel List).....	127
Selecting a Channel (Direct Tune).....	127
Selecting a Channel (Voice Recognition).....	128
Scanning SiriusXM Channels.....	128
Tagging an Artist or Song.....	128
Viewing Tagged List.....	129
Tag Alert.....	129
SiriusXM Categories.....	129
Game Zone.....	130
Enabling Sports Alerts.....	130

# TABLE OF CONTENTS

---

Adding a Game Zone Favorite.....	130
Setting Game or Score Notification.....	131
Responding To Game Zone Alert.....	131
Removing a Game Zone Favorite.....	132
Displaying Current Weather.....	132
Displaying Daily Forecast (3 and 6 hour).....	133
Displaying 5 Day Forecast.....	134
SiriusXM Fuel Prices.....	134
Selecting Fuel Type.....	134
Viewing Fuel Prices.....	135
SiriusXM Traffic.....	136
Turning Traffic On.....	136
Traffic Notification Popups.....	136
Traffic Icons.....	136
Traffic Reroute.....	136
Traffic Message List.....	137
SiriusXM Weather Map.....	138
Weather Map Scrolling.....	139
Weather Map Radar and Fronts.....	139
Display Last Weather Update.....	141

## NAVIGATION

Navigation.....	143
Displaying the Map.....	144

Changing Map Display.....	147
Changing Data Fields.....	148
Navigation Option Menu.....	148
Route Preferences and Avoidances.....	148
Compass.....	149
Compass/Heading Indicator on Map.....	149
Full Size Compass.....	150
Map Scrolling (Touchscreen).....	151
Map Scrolling (Hand Controls).....	151
Selecting POI On Map.....	152
Route To Destination (Address).....	154
Route To Destination (Home).....	155
Route To Destination (Recent).....	155
Route To Destination (Phone Book).....	156
Route To Destination (Saved).....	156
Route To Destination (Map Scroll Tool).....	156
Route To Destination (POI).....	157
Route To Destination (Dealership).....	158
Route To Destination (Emergency).....	158
Route To Destination (Coordinates).....	159
Route To Destination (SiriusXM Fuel Prices Feature).....	160
Route To Destination (Voice Command).....	160
Canceling a Route (Using Menus).....	160
Canceling a Route (Voice Command).....	160

# TABLE OF CONTENTS

Trips.....	160	Simulating a Route.....	172
Creating a Trip (Using Menus).....	161	Calling a Destination (Route Active).....	173
Creating a Trip (Using Map).....	161	Calling a Destination (Route Not Active).....	173
Round Trip.....	161	Trip Summary.....	173
Editing a Trip (Adding Waypoints).....	162	Low Fuel Alert.....	174
Editing a Trip (Reordering Waypoints).....	162	GPS Information.....	174
Editing a Trip (Skipping Waypoints).....	162	Traffic.....	175
Trails.....	163	Turning Traffic On/Off.....	176
Record a Trail (Options Menu).....	163	Traffic Notification Settings.....	176
Record a Trail (Trails Menu).....	163	Rerouting.....	176
Rename a Trail.....	164	Traffic Event List (RDS Traffic).....	177
Navigating a Trail.....	164	Navigation Prompts (Turning On/Off).....	177
Deleting a Trail.....	164	Navigation Prompts (Adjusting Volume Using Menus)....	178
Exporting a Route.....	164	Navigation Prompts (Adjusting Volume with Hand Controls).....	178
Importing a Route.....	165	Navigation Prompts (Speaker/Headset Selection).....	178
Exporting a Ride Planner Route.....	166	Navigation Database.....	178
Maneuvers (Turn-By-Turn Instructions).....	168	Verifying Database Version.....	178
Displaying a Maneuver (Zoom).....	169	Download Hardware/System Requirements.....	179
Avoiding a Road.....	170	Updating Database.....	179
Restoring an Avoided Road.....	170	Replacing the Intercontinental Database.....	180
Lane Guidance.....	170	Restoring an Intercontinental Database.....	181
Saving a Destination (Saved, Preferred or Home).....	171		
Saving Current Location.....	172		
Showing a Planned Route.....	172		

# TABLE OF CONTENTS

---

## VOICE RECOGNITION

Voice Recognition.....	183
Activating Voice Recognition.....	183
Cancelling Voice Recognition.....	183
Teleprompter.....	184
Command List.....	184
Pick List.....	185
Prompter Responds "Pardon?".....	185
Voice Recognition Commands.....	186

## VEHICLE INFORMATION

Vehicle Information.....	193
--------------------------	-----

## CARE AND CLEANING

Audio System Care.....	195
Replaceable Screen Protector.....	195
Cleaning the Radio.....	195
Speaker Care.....	195

## LIMITED RADIO WARRANTY

2015 Limited Radio Warranty.....	197
Other Rights.....	198

## LIMITED RADIO WARRANTY (AUSTRALIA)

Australia/New Zealand 2015 Limited Radio Warranty.....	199
Your Consumer Rights.....	199
Warranty.....	199
Warranty Period.....	199
Exclusions.....	200
Obtaining Warranty Service.....	200

## FCC CITIZENS BAND INFORMATION

What Every Responsible Citizens Band (CB) Station Operator Should Know as Prepared by the Federal Communications Commission, Washington, D.C.....	201
Subpart D-Citizens Band (CB) Radio Service General Provisions.....	201
How to Operate a CB Station.....	203
OTHER THINGS YOU NEED TO KNOW.....	209

## TRADEMARKS

H-D U.S.A., LLC Trademark Information.....	213
Product Registered Marks.....	213



## SAFETY INFORMATION

### WARNING

Set volume levels and other controls on audio and electronic devices before riding. Distractions can lead to loss of control, resulting in death or serious injury. (00088b)

### WARNING

Set CB channel, squelch threshold and volume before riding to minimize adjustments on the road. Distractions can lead to loss of control, resulting in death or serious injury. (00089a)

### WARNING

Do not select a volume level that blocks out traffic noise or interrupts the concentration necessary for safe operation of the motorcycle. Distractions or a volume level that blocks out traffic noise could cause loss of control resulting in death or serious injury. (00539b)

### NOTICE

There are no serviceable parts inside the unit; leave all servicing to qualified service personnel. Disassembly of the unit could result in equipment damage and/or equipment malfunction. (00172a)

This manual explains the operation of the Boom!™ Box Infotainment system. Investing time to learn about the features and operation of your motorcycle and its infotainment system will lead to safe enjoyable use of its full range of features. Read this manual carefully and keep it with your motorcycle at all times for reference. An online copy of this manual is available at [www.h-d.com/boom](http://www.h-d.com/boom) (or the Boom! Box section on [www.h-d.com/touring](http://www.h-d.com/touring)).

See the owner's manual for your vehicle for important rider safety information.

Follow all the warnings, cautions and safety tips shown throughout this manual and your vehicle manual.

See Figure 1 and Figure 2. Do not use any feature of this system to the extent it becomes a distraction and prevents safe riding. The first priority while riding should always be the safe operation of the vehicle. While riding, observe all traffic regulations.

Pay attention while riding. Always concentrate on riding by keeping your eyes and mind on the road. To prevent distraction, some features are locked out, unavailable or limited in capability

while the motorcycle is in motion. Even if a feature is available, do not allow it to distract you from operating the motorcycle safely.

For safety, program the system when stopped. Perform system setup and get familiar with the controls and features of the infotainment system before operating the motorcycle on the road.

This system cannot warn about such things as the safety of an area, road conditions and availability of emergency services.

Use this system only in locations where it is legal to do so.

For additional instruction and information for setting up or operating the system, see an authorized Harley-Davidson dealer and online resources at [www.h-d.com/boom](http://www.h-d.com/boom) (or the Boom! Box portion of [www.h-d.com/touring](http://www.h-d.com/touring)).



**Figure 1. Acceptance Screen: 4.3 Models**



**Figure 2. Acceptance Screen: 6.5 Models**

## 2 Safety First



**Figure 3. Vehicle in Motion Message**

## NAVIGATION

The navigation, lane guidance and traffic features are intended to assist you when traveling. Always use personal judgment and observation of the actual road conditions while riding. In some circumstances, information provided in the navigation database may be incomplete, incorrect or outdated. Road conditions, traffic laws and restrictions (such as no left turns, street closures, one way streets, road construction detours, and so on) can frequently change. Before following any instruction from the system, check whether the instruction can be done safely and legally.

If necessary, safely park the vehicle if there is difficulty following the route guidance or if there is a need to program a new route. In some circumstances, the system could temporarily provide an inaccurate position of the vehicle or show errors in distance between objects.

When importing routes from other devices or websites, understand that there may be limitations to the accuracy or reliability of the imported data. There may also be compatibility limitations when importing data files from another device or website.

Program and review navigation routes with the vehicle stopped. When taking a long trip, plan and review the route before riding the motorcycle. Install updates to the navigation database to make sure you have the latest information available.

## PRE-RIDE CHECKLIST

Before riding the motorcycle, set up and customize the system so it operates in a way that works for you while minimizing

distraction on the road. At a minimum, consider setting up the following items before riding.

- Set brightness, background color and day/night color mode
- Configure presets and favorites
- Select tuning mode (tune/seek/preset)
- Adjust audio settings (volume, tone, fade and headset/speaker selection)
- Pair, connect and set up phone features through Bluetooth
- Connect USB devices
- Select station or media to be played
- Set up trips and navigation
- Set up CB and intercom

- Connect and put on headsets

## **EMERGENCY PHONE NUMBER**

Setting up an emergency phone number can provide access to help when needed. See PHONE, Making a Call (Emergency Phone Number).

Phone numbers and navigation to nearby emergency resources are also available on equipped systems. See NAVIGATION, Route To Destination (Emergency).

## **EMERGENCY CB OPERATION**

For vehicles equipped with a CB, channel 9 is reserved for emergency use in most countries. When using this channel for emergencies or assistance, clearly identify the nature of the problem and your location. If no response is received, try other channels or find another way to get help.

## FEATURES, OPTIONS AND SPECIFICATIONS

Not all features are available on all models. Most screen illustrations in this manual show the 6.5 radio.

Vehicles are equipped from the factory with the radios and features as described in Table 1, Table 2 (4.3 radio features)

and Table 3 (6.5 radio features). See the Vehicle Identification Number (VIN) information in your vehicle owner's manual to determine the configuration/calibration of your motorcycle. Also see SYSTEM SETTINGS, System Information to view the hardware, software and navigation database installed on your vehicle.

**Table 1. 2015 Radio Model Configurations**

RADIO	PART NUMBER	MODEL	CONFIGURATION
4.3	76000075	FLHX	49 STATES, CALIFORNIA, CANADA
		FLHTCU	49 STATES, CALIFORNIA, CANADA
		FLHTCUL	49 STATES, CALIFORNIA, CANADA
		FLTRX	49 STATES, CALIFORNIA, CANADA
4.3	76000230	FLHTCU	CANADA
		FLHTCUTC	ASIA-PACIFIC, AUSTRALIA, ENGLAND, HDI, JAPAN
		FLHTCUL	CANADA
		FLHTCULTC	ASIA-PACIFIC, HDI, JAPAN

**Table 1. 2015 Radio Model Configurations**

<b>RADIO</b>	<b>PART NUMBER</b>	<b>MODEL</b>	<b>CONFIGURATION</b>
6.5GT	76000076	FLHTCU	49 STATES, CALIFORNIA, CANADA
		FLHTCUL	49 STATES, CALIFORNIA, CANADA
		FLHXS	49 STATES, CALIFORNIA, CANADA
		FLHTK	49 STATES, CALIFORNIA, CANADA
		FLHTCUTG	49 STATES, CALIFORNIA, CANADA
		FLHTKL	49 STATES, CALIFORNIA, CANADA
		FLTRXS	49 STATES, CALIFORNIA, CANADA
6.5GT	76000231	FLHTK	ENGLAND, HDI
		FLHTCUTG	ENGLAND, HDI
		FLHXS	ENGLAND, HDI
		FLHTKL	ENGLAND, HDI
		FLTRXS	ENGLAND, HDI
6.5GT	76000228	FLHTKSE	49 STATES, CALIFORNIA, CANADA
		FLTRUSE	49 STATES, CALIFORNIA, CANADA
		FLHXSE	49 STATES, CALIFORNIA, CANADA

**Table 1. 2015 Radio Model Configurations**

<b>RADIO</b>	<b>PART NUMBER</b>	<b>MODEL</b>	<b>CONFIGURATION</b>
6.5GT	76000229	FLHTKSE	ENGLAND, HDI
		FLTRUSE	ENGLAND, HDI
		FLHXSE	ENGLAND, HDI
6.5GT	76000232	FLHTK	ASIA-PACIFIC, AUSTRALIA, BRAZIL, CANADA, HDI, JAPAN
		FLTHTCUTG	CANADA, HDI, JAPAN
		FLHTKSE	ASIA-PACIFIC, AUSTRALIA, BRAZIL, CANADA, HDI, JAPAN
		FLHXS	ASIA-PACIFIC, AUSTRALIA, BRAZIL, CANADA, HDI, JAPAN
		FLHTKL	ASIA-PACIFIC, CANADA, HDI, JAPAN
		FLTRXS	ASIA-PACIFIC, AUSTRALIA, CANADA, HDI, JAPAN
		FLTRUSE	ASIA-PACIFIC, AUSTRALIA, BRAZIL, CANADA, HDI, JAPAN
		FLHXSE	ASIA-PACIFIC, AUSTRALIA, BRAZIL, CANADA, HDI, JAPAN

**Table 2. Boom! Box 4.3 Models - Features and Options**

	4.3 Part No. 7600075	4.3 Part No. 7600230
<b>DISPLAY</b>		
Type	4.3-inch QVGA LCD color screen	
Adjustable Brightness	Selectable or automatic sensor-activated brightness for screen and faceplate controls	
Day/Night Color Mode	Selectable day, night or automatic sensor-activated color modes	
Interface Languages	English (US), English (UK), Spanish (Mexican), Spanish (Castilian), French (Canadian), French (France), Italian, European Portuguese	
<b>AUDIO OUTPUT</b>		
Watts Per Channel	25	
Speakers	2 (FLHX, FLTRX) 4 (FLHTCU/TC, FLHTCUL/TC)	
Speaker Size	5.25 inch 6.5 inch - P&A Upgrade	
Sealed and Closed Front Speaker Housing	Standard	
Bass Port Rear Speakers	Standard (except FLHX, FLTRX)	
Distortion (THD)	1%	
Internal Amp	Standard	
External Amp	P&A Upgrade	
Wired Headset	Standard (FLHTCU, FLHTCUL) P&A Upgrade (FLHX, FLTRX)	Standard (FLHTCU/TC, FLHTCUL/TC) P&A Upgrade (FLHX, FLTRX)
Headset Specifications (if equipped)	16-64 ohms	

8 Features and Specifications



**Table 2. Boom! Box 4.3 Models - Features and Options**

	4.3 Part No. 7600075	4.3 Part No. 76000230
<b>AUDIO SOURCES</b>		
AM	Standard	Not supported
FM	Standard	Standard
Weather Band (WB)	Standard	Dependent on region
MW	Not supported	Standard
LW	Not supported	Standard
Media player (via USB Connection)	Supported	Supported
Media player (via Bluetooth Connection)	Supported	Supported
SD Card (via USB Connection)	Supported	Supported
Flash Drive (via USB Connection)	Supported	Supported

**Table 2. Boom! Box 4.3 Models - Features and Options**

	4.3 Part No. 76000075	4.3 Part No. 76000230
<b>AUDIO SETUP</b>		
CB Presets (if equipped)		6
AM/MW/LW Presets		6
FM Presets		15
WB Presets		6
iPod Device Presets		20
USB-Storage Device Presets		20
Media Player Device Presets		20
Global Presets		Selectable, up to 20 presets
Classic Mode		Selectable
Favorites		Standard, 1 FAV hardkey plus 6 favorites
Seek/Scan		Standard
<b>VOICE RECOGNITION</b>		
Hands-free Mobile Phone (via Bluetooth)		Standard (FLHX/FLTRX requires P&A headset connection)
Voice Recognition Languages (Phone functions only)		English (US)
<b>COMMUNICATION</b>		
Rider/Passenger Intercom		Standard (FLHTCU/TC, FLTHCUL/TC) Not supported (FLHX, FLTRX)
Bike-to-Bike (CB)		P&A Upgrade (FLHTCU/TC, FLHTCUL/TC pre-wired)

**Table 2. Boom! Box 4.3 Models - Features and Options**

	4.3 Part No. 7600075	4.3 Part No. 76000230
<b>OTHER FEATURES</b>		
Vehicle Information Screen (ambient air temperature, oil pressure and EITMS)	Standard	
Software Update (via USB interface)	Standard	
Text-to-Speech (TTS) Languages	English (US)	
USB	USB/iPod/iPhone/Media Transfer Protocol (MTP)	
Bluetooth	Phone/Media supported	

**Table 3. Boom! Box 6.5 Models - Features and Options**

	6.5GT Part No. 76000076	6.5GT Part No. 76000231	6.5GT Part No. 76000228	6.5GT Part No. 76000229	6.5GT Part No. 76000232
<b>SCREEN</b>					
Type	6.5-inch QVGA TFT LCD color touchscreen with replaceable screen protector				
Color Options	Orange (default), Blue, Brown, Green, Gray, Purple, Red				
Adjustable Brightness	Selectable or automatic sensor-activated brightness for screen and faceplate controls				
Day/Night Color Mode	Selectable day, night or automatic sensor-activated color modes				
Interface Languages	English (US), English (UK), Spanish (Mexican), Spanish (Castilian), French (Canadian), French (France), Italian, European Portuguese				

**Table 3. Boom! Box 6.5 Models - Features and Options**

	<b>6.5GT Part No. 76000076</b>	<b>6.5GT Part No. 76000231</b>	<b>6.5GT Part No. 76000228</b>	<b>6.5GT Part No. 76000229</b>	<b>6.5GT Part No. 76000232</b>
<b>AUDIO OUTPUT</b>					
Watts Per Channel	25	25	75	75	25 75 (FLHTKSE, FLTRUSE, FLHXSE)
Speakers	2 (FLHXS, FLTRXS) 4 (all others)		4		
Speaker Size	5.25 inch 6.5 inch - P&A Upgrade		6.5 inch		5.25 inch 6.5 inch (FLHTKSE, FLTRUSE, FLHXSE) 6.5 inch - P&A Upgrade
Sealed and Closed Front Speaker Housing	Standard				
Bass Port Rear Speakers	Standard (except FLHXS, FLTRXS)		Standard		Standard (except FLHXS, FLTRXS)
Distortion (THD)	1%				
Internal Amp	Standard				
External Amp	P&A Upgrade		Standard		Standard (FLHTKSE, FLTRUSE, FLHXSE) P&A Upgrade (FLHTK/L, FLHTCUTG, FLHXS, FLTRXS)
Wired Headset	Standard (P&A Upgrade FLHXS, FLTRXS)		Standard		Standard (P&A Upgrade FLHXS, FLTRXS)
Headset Specifications (if equipped)	16-64 ohms				
<b>AUDIO SOURCES</b>					

**Table 3. Boom! Box 6.5 Models - Features and Options**

	<b>6.5GT Part No. 76000076</b>	<b>6.5GT Part No. 76000231</b>	<b>6.5GT Part No. 76000228</b>	<b>6.5GT Part No. 76000229</b>	<b>6.5GT Part No. 76000232</b>
AM	Standard	Not supported	Standard	Not supported	Dependent on Region
FM	Standard	Standard	Standard	Standard	Dependent on Region
Weather Band (WB)	Standard	Not supported	Standard	Not supported	Dependent on Region
MW	Not supported	Standard	Not supported	Standard	Dependent on Region
LW	Not supported	Standard	Not supported	Standard	Dependent on Region
SiriusXM Satellite Radio	P&A Upgrade		Standard (requires activation)		FLHTKSE, FLTRUSE, FLHXSE (CAN, requires activation)
Media player (via USB Connection)	Supported				
Media player (via Bluetooth Connection)	Supported				
SD Card (via USB Connection)	Supported				
Flash Drive (via USB Connection)	Supported				

**Table 3. Boom! Box 6.5 Models - Features and Options**

	6.5GT Part No. 76000076	6.5GT Part No. 76000231	6.5GT Part No. 76000228	6.5GT Part No. 76000229	6.5GT Part No. 76000232
<b>AUDIO SETUP</b>					
CB Presets (if equipped)			6		
AM/LW/MW Presets			6		
FM Presets			15		
SiriusXM Presets (if equipped)			20		
WB Presets			6		
iPod Device Presets			20		
USB Storage Device Presets			20		
Media Player Device Presets			20		
Global Presets			Selectable, up to 20 presets		
Classic Mode			Selectable		
Favorites			Standard, 1 FAV hardkey plus 6 favorites		
Seek/Scan			Standard		

**Table 3. Boom! Box 6.5 Models - Features and Options**

	6.5GT Part No. 76000076	6.5GT Part No. 76000231	6.5GT Part No. 76000228	6.5GT Part No. 76000229	6.5GT Part No. 76000232
<b>VOICE RECOGNITION</b>					
Voice Recognition Functions	Hands-free Mobile Phone (via Bluetooth), Tuner, Media, Navigation (FLHXS/FLTRXS requires P&A headset connection)				
Voice Recognition Languages (Tuner, Media, Phone, Navigation commands)	English (US/UK), German, Spanish (Mexico/Spain), French (Canada/France), Italian, European Portuguese				
Voice Recognition Languages (One Shot Destination Entry, where supported by country)	English (US), Spanish (Mexico), French (Canada)	English (UK), German, Spanish (Spain), French (France), Italian, European Portuguese	English (US), Spanish (Mexico), French (Canada)	English (UK), German, Spanish (Spain), French (France), Italian, European Portuguese	None
<b>NAVIGATION</b>					
Integrated Navigation	Standard				Compass where not available.
Navigation Database	North American	European	North American with 3D Building/Landmarks	European with 3D Building/Landmarks	Option, if available. Compass if not available.
<b>COMMUNICATION</b>					
Rider/Passenger Intercom	Standard (FLHTCU/L, FLHTK/L, FLHTCUTG)		Standard		
Bike-to-Bike (CB) - Prewired	Standard (FLHTCU/L, FLHTK/L, FLHTCUTG)		Standard		Not available
Bike-to-Bike (CB)	Standard (FLHTK/L) P&A Upgrade (FLHTCU/L, FLHTCUTG)		Standard		Not available

**Table 3. Boom! Box 6.5 Models - Features and Options**

	6.5GT Part No. 76000076	6.5GT Part No. 76000231	6.5GT Part No. 76000228	6.5GT Part No. 76000229	6.5GT Part No. 76000232
<b>OTHER FEATURES</b>					
Vehicle Information Screen (ambient air temperature, oil pressure and EITMS)	Standard				
Software Update (via USB interface)	Standard				
Text-to-Speech (TTS) Languages	English (US/UK), German, Spanish (Mexico/Spain), French (Canada/France), Italian, European Portuguese				
USB	USB/iPod/iPhone/Media Transfer Protocol (MTP)				
Bluetooth	Phone/Media supported				



# INFOTAINMENT CONTROLS

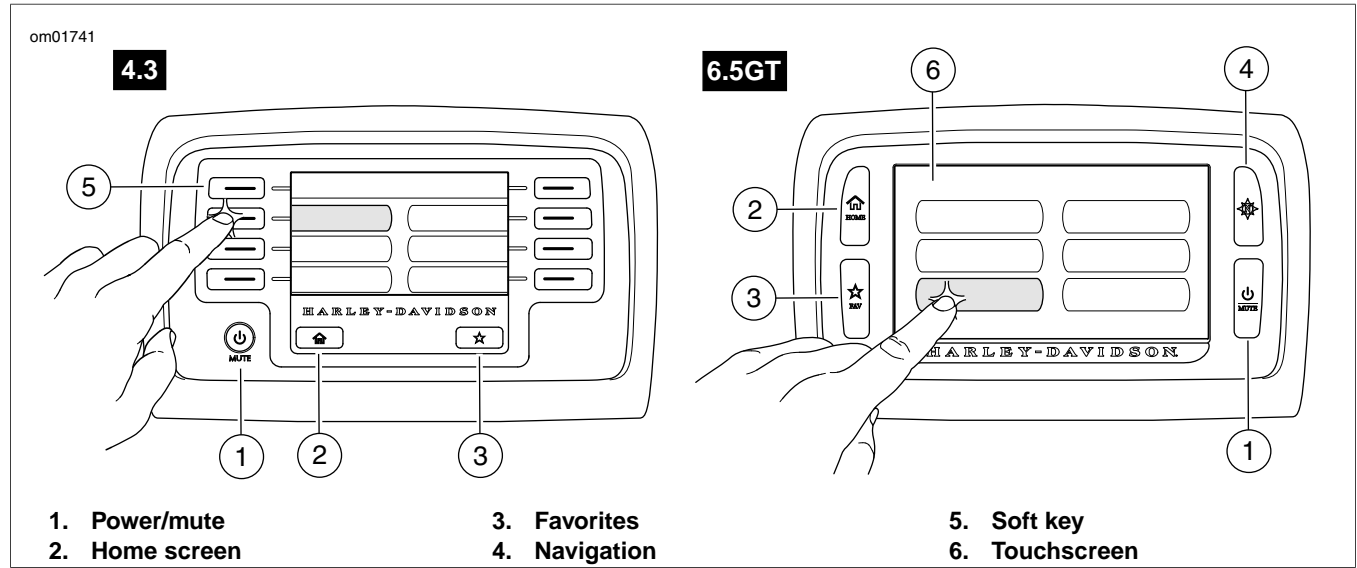

Figure 4. Boom! Box Infotainment System

## POWER/MUTE SWITCH

When turning on the motorcycle, the radio will resume its previous state (radio on or off).

**Power On:** With the motorcycle turned on or in accessory mode, press POWER/MUTE switch to turn the system on. The system returns to the last state as when it was last turned off (media file, station, and so on).

**Power Off:** Press and hold the POWER/MUTE switch for three seconds to turn the system off. The screen goes black and the clock is displayed. The radio remains in sleep mode and continues to draw current while the motorcycle is turned on or in accessory mode. The radio will not reinitialize unless the vehicle is turned off for up to 30 seconds.

**Mute/Pause:** Briefly press POWER/MUTE to mute audio. Radio stations, CB, intercom, navigation audio, and prompts will be muted. Media devices will be paused.

**Unmute/Resume:** To resume audio or media files, briefly press POWER/MUTE switch again.

## NOTES

- *Audio can also be unmuted by pressing the volume switches on the left hand controls.*
- *Media can also be resumed by pressing the PREVIOUS/NEXT switch on the left hand controls.*
- *Phone call audio will not be muted with the POWER/MUTE switch. Use the Mute function in the phone menu to mute inbound/outbound phone audio during a call. See PHONE, Muting Call Audio.*

## HOME SWITCH

Press the HOME switch to display the Home screen. Press the switch again to show the current audio source (tuner station, media file, or phone screen).

## FAVORITE SWITCH (FAV)

The favorite (FAV) switch can be set to one audio source (radio station, tuner band, media file, or media player). After the FAV switch has been set, briefly press the switch to begin playing the selected audio source.

**Setting FAV switch (tuner band):** Press and hold FAV switch. Select **Tuner**. Select desired band (AM, FM, WB, and so on).

**Setting FAV switch (radio station):** Tune to a desired station (such as 105.7 FM or WB1). Press and hold FAV switch. Select the desired station on the screen.

**Setting FAV switch (media player):** With media player connected to the USB port, press and hold FAV switch. Select the media player on the screen.

**Setting FAV switch (media file):** With a media file playing, press and hold the FAV switch. Select the media file on the screen.

**Listening to favorite:** Briefly press the FAV switch. The band, station, or media will begin playing. Any media files or devices stored as a favorite must be connected to the USB port.

#### NOTES

- *The FAV switch only stores one audio source. The Favorites list on the Home screen is a separate feature which can store multiple presets. See FAVORITES.*
- *To overwrite the currently stored favorite, repeat the procedure for setting the favorite.*
- *The FAV switch cannot be set to navigation locations, phone features, or CB channels.*

## NAVIGATION SWITCH (6.5 ONLY)

**Navigation Menu/Map:** Press the NAVIGATION switch to display the navigation menu (or navigation map, if active). Press the switch again to toggle between the map and navigation menu.

**Display Audio Source on Map:** While map is displayed, press and hold the NAVIGATION switch. The current audio source (radio station or media file) will be displayed along the bottom of the map screen. Press and hold the switch again to hide the audio source.

**Compass:** For 6.5 radios without navigation, press the NAVIGATION switch to display the compass.

See NAVIGATION to configure and operate the navigation features.

## SOFT KEYS (4.3 ONLY)

See Figure 4. Press the soft keys along the left and right side of the screen to select menu items and operate the system. Press the softkey that aligns with the desired function on the screen as shown.

## TOUCHSCREEN (6.5 ONLY)

See Figure 4. Press on the touchscreen to select menu items and operate the radio. The touchscreen can be operated while wearing riding gloves.

The screen is designed to minimize glare, be viewable in all lighting conditions, and be operable in wet weather conditions. The touchscreen is covered with a replaceable protective film. Keep this screen protector on the screen at all times to prevent damage to the screen. Damage to the screen due to use without the screen protector will not be covered under warranty. Remove and replace the protector if it becomes dull, scratched or worn.

To properly care for the radio faceplate and touchscreen, see CARE AND CLEANING.

## BOOM! BOX HAND CONTROLS

Some features and functions shown are model and/or region-specific.

See the vehicle owner's manual for functionality of other hand control switches.

## Left Hand Control Audio Functions

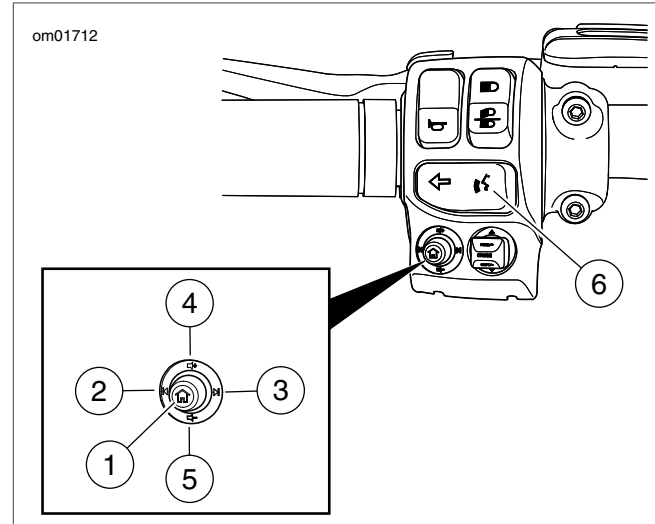





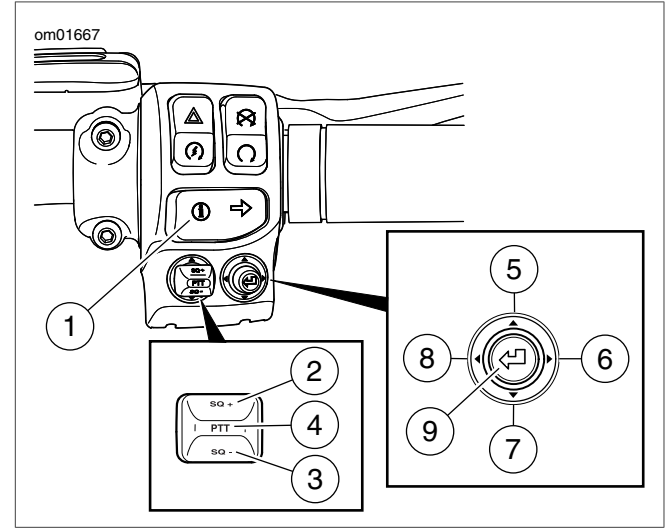

Figure 5. Left Hand Control Audio Functions (Typical)

**Table 4. Left Hand Control Audio Functions**







ITEM	ICON	NAME	FUNCTION
1		Home	Toggles between current screen and Home screen
2		Previous /Seek Down	<b>Media:</b> Previous media file. <b>Tuner:</b> Tune/seek/next preset down.
3		Next/Seek Up	<b>Media:</b> Next media file. <b>Tuner:</b> Tune/seek/next preset up.
4		Volume Up	Increases volume
5		Volume down	Decreases volume
6		Voice Recognition	Initiates a voice recognition session

## Right Hand Control Audio Functions



**Figure 6. Right Hand Control Audio Functions (Typical)**

Table 5. Right Hand Control Audio Functions

ITEM	ICON	NAME	FUNCTION
1		Information	Displays or exits Vehicle Information
2	<b>SQ +</b>	CB Squelch +	<b>If Equipped:</b> Increases CB squelch level
3	<b>SQ -</b>	CB Squelch -	<b>If Equipped:</b> Decreases CB squelch level
4	<b>PTT</b>	CB Push to Talk	<b>If Equipped:</b> Press and hold to transmit over CB.
5		Cursor Up	Moves the highlighting up through the selections.
6		Cursor Right	Moves the highlighting right through the selections.
7		Cursor Down	Moves the highlighting down through the selections.
8		Cursor Left	Moves the highlighting left through the selections.
9		Select /Enter	Selects the highlighted item or used to indicate data entry is complete.

## HOME/VOLUME/PREVIOUS/NEXT SWITCH

See Figure 5. The HOME/VOLUME/PREVIOUS/NEXT five-way switch operates radio features on equipped vehicles.

The operation of the HOME switch depends on whether the Classic Mode setting is enabled. To enable or disable Classic Mode, see SYSTEM SETTINGS, Classic Mode.

**HOME (normal mode):** Press the HOME switch to display the Home screen. Press the switch again to display the current audio source (tuner station, media file, or phone screen).

**HOME (Classic Mode):** Press the HOME switch to toggle through available audio sources (tuner bands, media player connected through USB, or Bluetooth connected device). This operates similar to the MODE SEL switch on previous Harley-Davidson motorcycles. To display the Home screen, press and hold the HOME switch on the handlebar or use the HOME switch on the radio faceplate.

**PREVIOUS/NEXT:** Press the switch to the left or right to seek up/down for a radio station or to select the previous/next media file. Within the Tuner menus, this switch can be configured to advance to the next frequency (tune), the next station (seek) or the next preset. See TUNER, Tune/Seek/Preset Settings.

**VOLUME:** Press the switch up to increase volume or down to decrease volume to the speakers or rider headset. The volume control can also unmute audio and resume media.

#### NOTES

- *Unlike the MUTE switch, decreasing volume to zero does not pause media.*
- *The volume output is also affected by the speed volume setting. See SYSTEM SETTINGS, Speed Volume.*
- *CB, intercom, phone calls and system prompts have independent volume levels. Adjust the volume for these different audio sources while they are active. See the sections for each of these functions for operation.*

## VOICE RECOGNITION SWITCH

See Figure 5. This switch activates the voice recognition features on equipped vehicles. With a headset connected, press the VOICE RECOGNITION switch. The radio beeps and shows a list of available commands. Speak the desired command into the headset microphone. See VOICE RECOGNITION.

To cancel voice recognition, press and hold the VOICE RECOGNITION switch for three seconds, or press the HOME hand control switch.

## PUSH-TO-TALK/SQUELCH SWITCH

**PTT:** Press the PTT switch to transmit over CB or intercom. Both the rider and passenger microphones are live. Intercom can also be operated by voice activation (VOX).

**Squelch (SQ+/SQ-):** Raise squelch (SQ+) to prevent noise or unwanted weak signals from unmuting the CB. Lower squelch (SQ-) to a level that allows desired CB signals to unmute the CB.

## CURSOR/SELECT SWITCH

See Figure 6. The CURSOR/SELECT five-way switch can be used to select items on the radio screen.

**CURSOR:** Press the switch in the desired direction to move the highlighted cursor to another selection on the radio screen.

**SELECT:** Press the switch straight in to select a highlighted item or toggle a feature on the radio screen.

## VEHICLE INFORMATION SWITCH

See Figure 6. Press the VEHICLE INFORMATION switch to vehicle status information on the radio screen. The vehicle information will display even if the radio is turned off. Press the switch again to exit the vehicle information screen. See VEHICLE INFORMATION.

## REAR (PASSENGER) CONTROLS

See Figure 7. Some vehicles have passenger controls on the right side of the Tour-Pak. These controls allow the passenger to operate functions in the radio.

### MODE/UP/DN Switch

**MODE:** Press switch straight in to select the next available audio source.

**UP/DN:** Press switch up/down to select the previous/next radio station or media file.

### Push-To-Talk (PTT)/Volume (VOL) Switch

**PTT:** Press switch to transmit over CB or intercom.

**VOL+/VOL-:** Press switch up (or down) to raise (or lower) the volume to the passenger headset. This switch does not affect the rider headset volume or speaker volume.

### Enabling Rear Controls

The PTT/VOL switch is always enabled. However, the MODE/UP/DN switch can be enabled or disabled through the setup screens. See SYSTEM SETTINGS, Rear Controls to enable these rear controls.

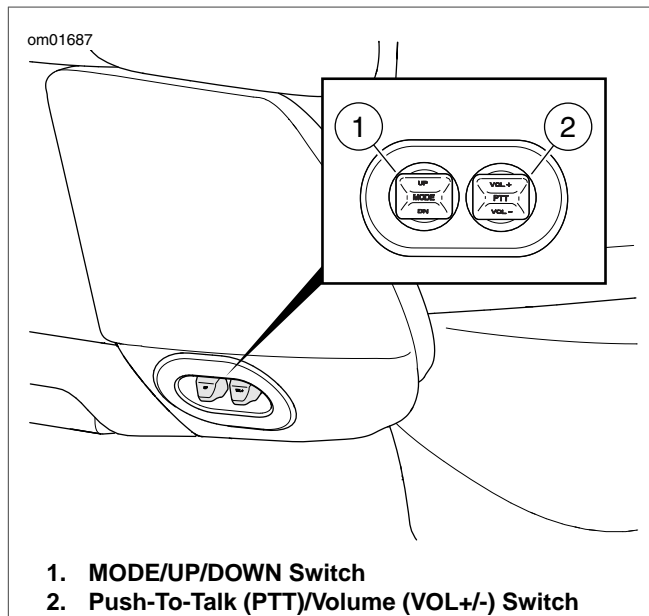

Figure 7. Passenger Controls



Table 6. Rear (Passenger) Control Audio Functions

ITEM	ICON	NAME	FUNCTION
1	<b>MODE</b>	Mode	Cycles to next available audio source.
	<b>UP</b>	Next/Seek Up	<b>Tuner:</b> Seek up. <b>Media:</b> Next file.
	<b>DN</b>	Previous /Seek Down	<b>Tuner:</b> Seek down. <b>Media:</b> Previous file.
2	<b>PTT</b>	CB Push-to-Talk	<b>If Equipped:</b> Press and hold to transmit over CB channel.
	<b>VOL+</b>	Volume Up	Increases volume.
	<b>VOL-</b>	Volume Down	Decreases volume.

## HEADSET CONNECTORS

### WARNING

**Do not select a volume level that blocks out traffic noise or interrupts the concentration necessary for safe operation of the motorcycle. Distractions or a volume level that blocks out traffic noise could cause loss of control resulting in death or serious injury. (00539b)**

### NOTICE

**Do not pull on the cord to remove the headset from the socket. Pull on the headset jack to disconnect the headset from the socket. (00174a)**

See Figure 8 and Figure 9. Some vehicles have a rider headset connector on the fuel tank panel and a passenger headset connector on the left speaker pod. The headsets are used to operate the CB, intercom, voice recognition commands and other features on equipped models.

Use the Harley-Davidson 7-pin DIN headset that is supplied with equipped models or purchased from a Harley-Davidson dealer. Other headset microphones are not compatible. See the instructions that are included with the headset to install in a helmet. Connect the headset by aligning the ridge on the

headset with the slot on the connector as shown in Figure 8. The headset only works if the connector is properly installed.

When using headsets, set the volume to a level where traffic and sounds from the surrounding environment can still be heard.

The socket caps remain shut when not in use to prevent dirt and water from entering the socket. Close both socket caps before washing the motorcycle.

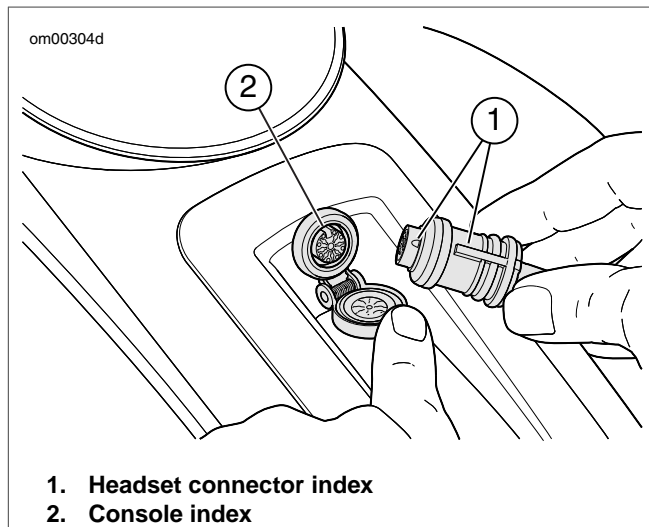

**Figure 8. Rider Headset Connector**

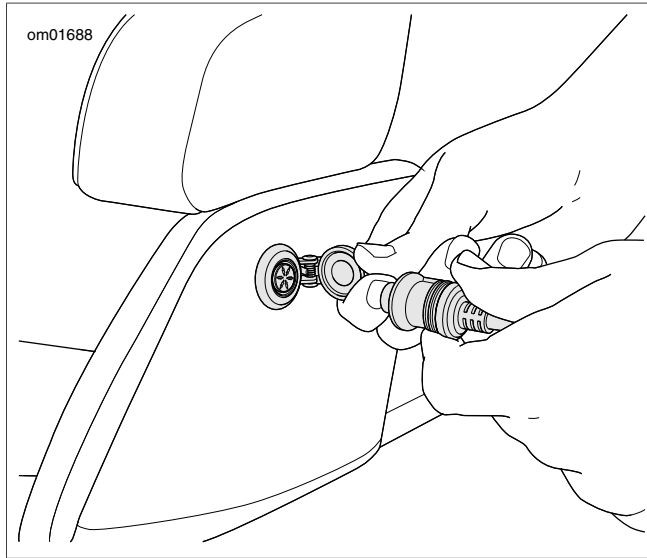
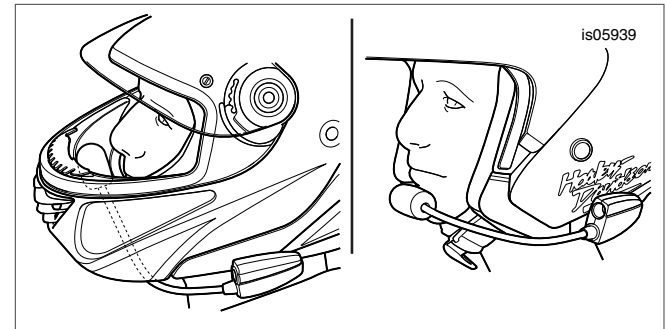

**Figure 9. Passenger Headset Connector**

## Microphone

**Microphone positioning (full face helmets):** See Figure 10. Route the boom below the helmet, with the microphone oriented upright inside the helmet, so the boom does not touch the chin.

**Microphone positioning (open face or half helmets):** See Figure 10 and Figure 11. Position the microphone lightly touching or directly to the left of the mouth.



**Figure 10. Microphone Positioning**

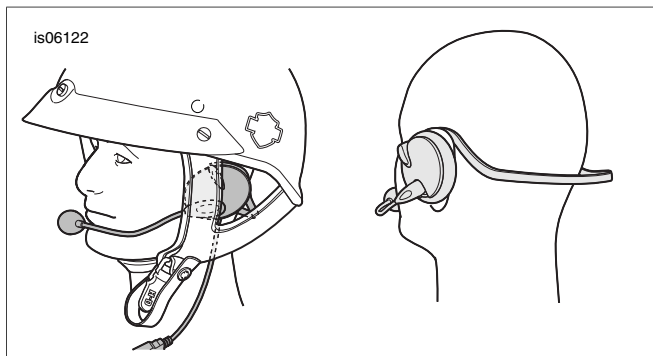

**Figure 11. Headset and Microphone Positioning**

## **MEDIA COMPARTMENT (USB PORT)**

See Figure 12 and Figure 14. The media compartment has a USB port to connect with a phone, media device or USB drive. An interface cable may be needed to connect with devices. The USB port is powered and operational when the vehicle is turned on or in accessory mode. Connected devices may be used for the following purposes.

**Phone:** Charges the phone and plays media files from the phone. However, phone calling and text messaging features are achieved only through Bluetooth connection.

**Media device:** Charges the device and plays media files.

**USB drive:** Plays media files, imports/exports navigation files, loads software updates, and imports ring tones.

**Memory card:** Some types of memory cards can be connected to play media files. Connection requires an adapter or reader.

### *NOTE*

*Do not use media players with hard drives. Vibration may cause internal damage to these players.*

Devices can be added or removed while the radio is on. However, when importing/exporting files or installing updates to the radio, do not disconnect the USB device until the task has completed.

Keep the compartment door closed while riding to prevent items from falling out. Remove valuable items from the media compartment before leaving the vehicle unattended.

## **Media Compartment (Fixed Fairing Vehicles)**

See Figure 12. Fixed fairing vehicles have a media compartment in the right side of the fairing.

**Open:** Pull up on the front of the compartment door to open as shown.

**Cleaning:** The rubber or fabric insert in the compartment is attached with hook and loop fastening tape and can be removed for cleaning.

## Media Compartment (Other Vehicles)

See Figure 13. Other vehicles have a media compartment on the right side of the radio as shown. Insert the phone or media device into the foam cradle to secure the device and isolate it from vibration.

**Open:** Push lower portion of door and release to open.

**Close:** Firmly push the door shut until the latch engages.

**Reset door latch:** If compartment door was forced open or is not latching properly, the door latch may need to be reset. Push the door shut. Open the door. Close the door again to engage the latch mechanism.

**Cleaning:** The cradle can be removed for cleaning or to assist with installing or removing a device from the compartment.

## USB Hub

A USB hub (not included) can be used to connect multiple USB devices to the radio simultaneously. The radio automatically begins playing media from the last connected device.

In the radio, select **Home > Media** to display a list of all connected devices. Music players are identified with a musical note icon. Other USB devices are identified with a USB icon.

### NOTES

- *Do not use a hub when installing software or map updates.*
- *Connecting too many items through a hub can exceed the charging current available through the USB port. Insufficiently powered hubs can impact radio compatibility.*

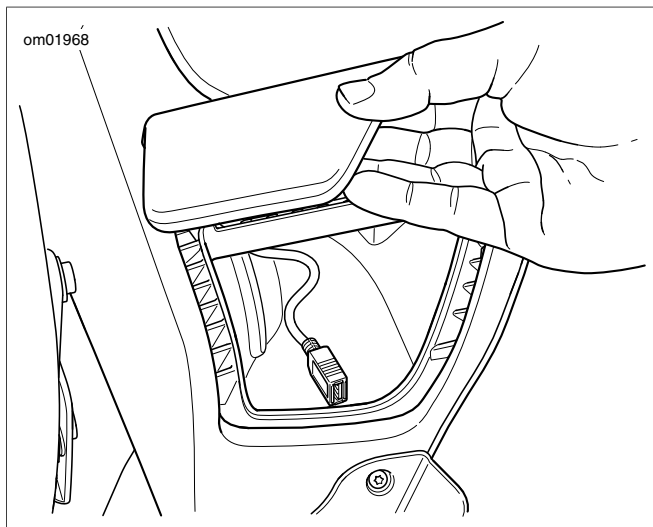

**Figure 12. Storage/Media Compartment (Fixed Fairing Models)**

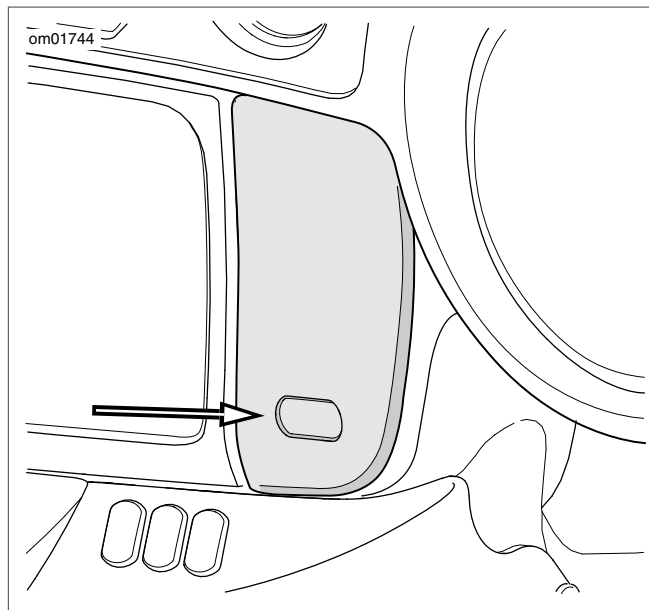

**Figure 13. Media Compartment (Other Models)**

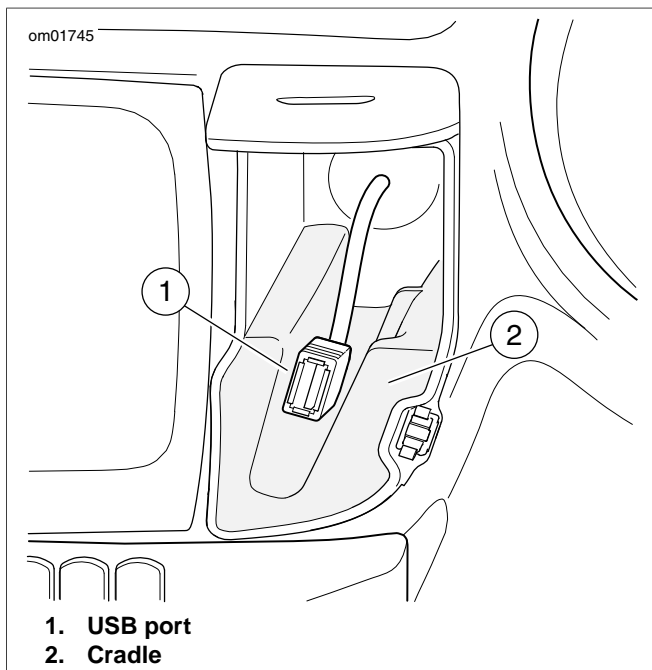

**Figure 14. USB Port**

## **SPEAKERS**

The speaker types and arrangements are different across models. All speakers are weatherproof and sealed for use in all riding weather conditions. See **CARE AND CLEANING** to properly care for speakers. See [www.h-d.com/store](http://www.h-d.com/store) for available speaker options.

### **Fairing Speakers**

Front speakers are designed into a ported enclosure in the fairing for additional bass response and higher fidelity. Models include different speaker specifications and arrangements within the inner fairing.

### **Fairing Lower Speakers**

Fairing lower speakers are equipped on some models to provide more volume for the sound system. These are also available as accessories for vehicles with air-cooled engines.

### **Saddlebag Speakers**

Saddlebag speakers are equipped on some models to provide additional surrounding volume for the sound system. These speakers use the saddlebag enclosure to provide enhanced bass response. A small amount of water may occasionally collect in the speaker cavities while parked outdoors. The saddlebag speakers are weatherproof, and the heat from

speaker operation would soon evaporate the water, but there could be a temporary effect on sound quality. To promptly empty the speaker cavities, lift the saddlebag lids. Saddlebag speakers are also available as accessories.

### **Tour-Pak Speakers (With Bass Boost Ports)**

The forward-facing speakers are equipped on models with a Tour-Pak to provide directed sound to the rider and passenger. The bass boost ports use the enclosed space in the Tour-Pak to provide an increased low end audio response with reduced distortion. The bass response of these ports may be affected when items are stored in the Tour-Pak or when the Tour-Pak lid is open.

### **AMPLIFIER**

Some vehicles include an additional amplifier to drive greater sound output to the speakers. Boom! audio amplifiers bypass the internal amplifier in the radio to provide increased volume, reduced clipping, lower Total Harmonic Distortion (THD), optimized equalization, and a fuller sound that cuts through wind and road noise. The amplifier is also available as an accessory.

Additional amplifiers may be needed when adding speakers to a vehicle.

## **ANTENNAS AND RECEPTION**

### ***NOTICE***

**Operating the CB radio without an antenna or with a broken antenna cable can result in damage to the transmitter circuitry. (00176a)**

**Tuner and CB antennas:** See Figure 15. Antennas on the rear of the vehicle may be removed during vehicle storage. Make sure to install antennas before operating the radio. To install, hand tighten the antennas to the mounts. Antennas for the tuner and CB are different. For vehicles with a CB, always install the CB antenna (marked with the letters "CB" at the base of the mast) on the right side of the motorcycle. The antenna marked "AM/FM" is for tuner reception. Installing the incorrect antenna for the tuner or CB will result in degraded reception.

**Hidden tuner antenna:** Some vehicles have an antenna installed in the fairing for tuner reception (AM/FM/WB).

**Satellite antennas:** SiriusXM and GPS antennas are mounted within the fairing on equipped models. These antennas require no maintenance. SiriusXM satellite radio and GPS reception may be weaker when the vehicle is indoors.



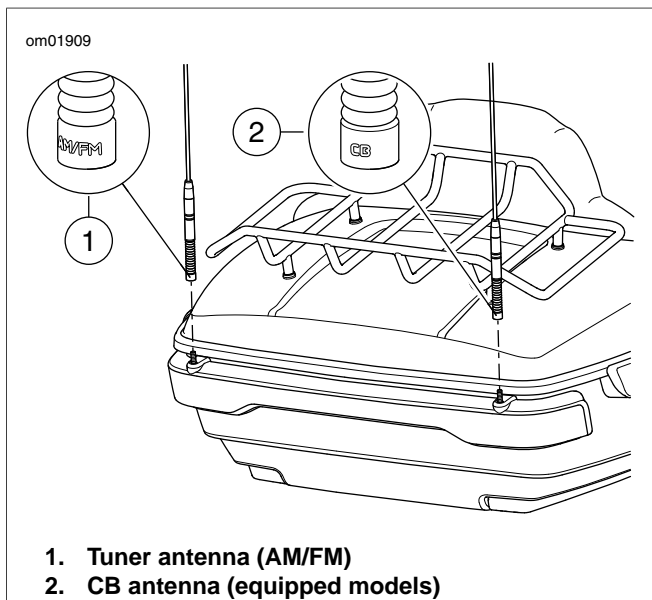

Figure 15. Antennas

## BLUETOOTH

The system is equipped with Bluetooth capability for accessing media files and phone operation. See **BLUETOOTH** to set up and connect devices.

## TURNING MOTORCYCLE ON, OFF OR TO ACCESSORY MODE

**Turning on motorcycle:** When the motorcycle is turned on, the radio returns to its previous state before shutdown. Features such as CB, intercom, current station or media playing resume as before the vehicle was turned off. A Bluetooth connection to the phone will attempt to resume.

**Starting the engine:** When starting the engine, the audio mutes and the screen turns off momentarily.

**Radio on/off:** If the radio is turned off before the vehicle is shutdown, it will remain turned off when the vehicle is turned back on.

**Restart radio:** To reinitialize the radio, allow the vehicle to remain turned off for up to 30 seconds before turning the vehicle back on.

**Accessory mode:** When the vehicle is in accessory mode, operation of the radio will result in some battery drain. The motorcycle will automatically turn off after two hours in

accessory mode. Keyed vehicles enter/exit accessory mode by turning the ignition switch to the appropriate position. Keyless vehicles enter/exit accessory mode by holding the trigger switch.

**Turning off motorcycle:** If turning off the motorcycle while in an active phone call, the radio will prompt to transfer the call back to the phone. If the prompt is not accepted, the radio will continue to support the call for approximately five minutes before automatically transferring the call back to the phone

and shutting down. See PHONE, Resuming Calls After Vehicle Shutdown.

## DISCONNECTING THE VEHICLE BATTERY

The system retains user data and system settings when the vehicle battery has been disconnected or main fuse is removed. Features such as navigation routes, paired devices, phone books, favorites, presets and system settings are retained in memory. The radio returns to its previous functionality after the battery is reconnected to the vehicle.

## HOME SCREEN

See Figure 16. The Home screen provides access to all the features available for the system. The layout of items on this screen may be different depending on radio type and installed features.

According to the radio type, use the touchscreen, softkeys or CURSOR/SELECT hand control switch to make selections and operate the system.

During initialization and startup, some features may be unavailable for a short time (such as navigation, SiriusXM, media and voice recognition).

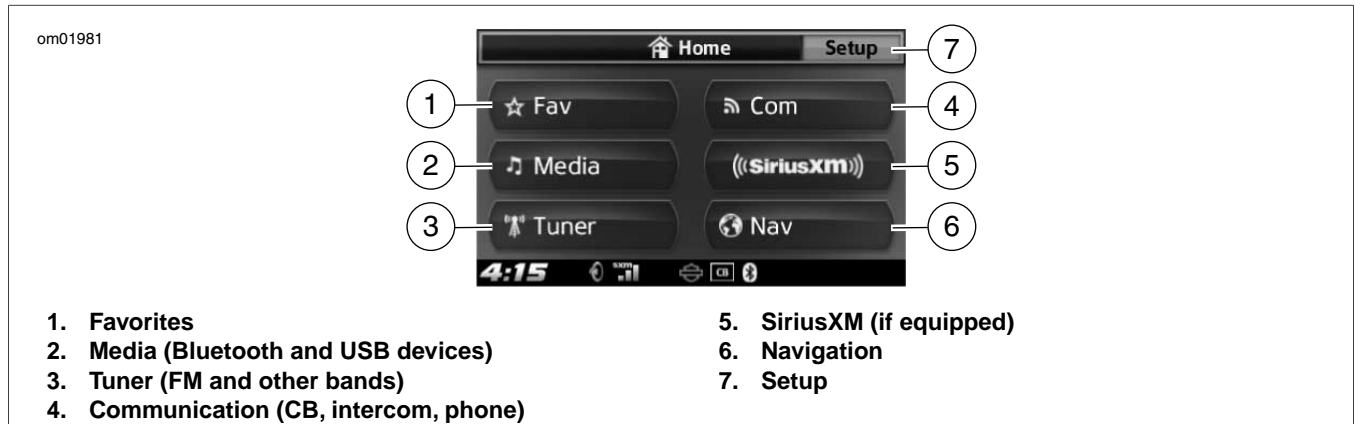

Figure 16. Home Screen (6.5 with SiriusXM shown)

## SCREEN MENU BAR

See Figure 17. Many screens have a menu bar at the top of the screen. The menu bar and its components change according to the screen being displayed.

**Title:** The title of the screen or function is located in the center of the menu bar. The screen title is not a selectable button.

**Buttons:** Some menu bars contain a selectable button on the right, left or both sides of the screen title. Some commonly used menu bar buttons are explained in Table 7.



Figure 17. Screen Menu Bar

Table 7. Menu Bar Buttons (Commonly Used)

BUTTON	DESCRIPTION
On/Off	Shows the current state of the feature (on or off). Press the button to turn the feature on or off.
Back	Returns to the previous screen.
Exit	Exits the current function. The system typically returns to the current audio source, Home screen or top level screen for the current function.
Menu	Displays a menu of options related to the current screen (navigation, media, and so on).
Repeat	Used on the navigation map and other screens that support text-to-speech functions (such as text messaging). Select the Repeat button to repeat a voice prompt, turn guidance, or text-to-speech reading.

## CHECKBOXES

See Figure 18. Some options are selected or enabled with a checkbox as shown.

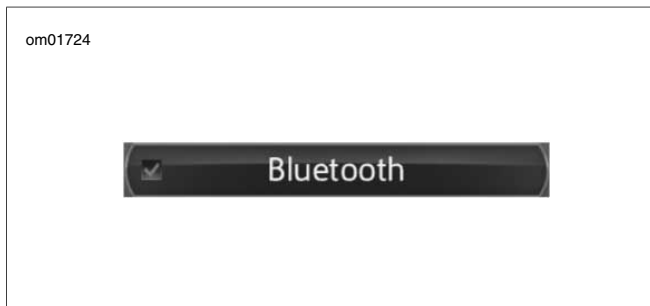

**Figure 18. Checkbox - Function Enabled (Typical)**

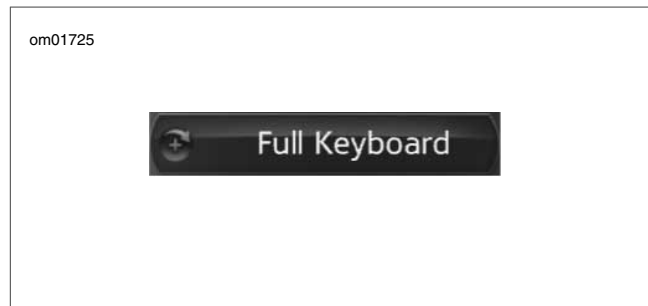

**Figure 19. Multiselect Button (Typical)**

## MULTISELECT BUTTON

See Figure 19. Multiselect buttons have a plus sign (+) with an arrow symbol on the button. The text shown on the button is the currently active setting.

Repeatedly press the multiselect button until the desired selection is displayed.

## SCROLL CONTROLS

See Figure 20. Scroll controls are displayed on the side of the screen when there is more than one page of available options. Use the soft keys, touchscreen or CURSOR/SELECT hand control switch to scroll through multiple pages of options. Press and hold the scroll controls to rapidly scroll through long lists.

Refer to Table 8. Some lists have a center button for functions such as letter jump, information, editing or reordering of the list.







om02039



1. Scroll up
2. List function (letter jump shown)
3. Scroll down

Figure 20. Scroll Controls

Table 8. List Buttons

BUTTON	NAME	DESCRIPTION
	Option menu	Opens a menu of additional options. Select the button again to return to the original screen.
	Letter jump	Jumps to a selected location within the list. For example, to jump to entries starting with the letter 'S', select the letter jump button, then select 'S' from the keyboard.
	Reorder	Changes the order of the list (such as sorting by distance or listing by alphabetical order).
	Edit	Select this button to view or edit information related to the list contents.
	Information	Displays more information related to the list contents.
	Delete	Deletes data associated with the list (such as all recent destinations).

## KEYBOARD

The keyboard is used for selecting navigation destinations, searching media files, saving contact information or entering other data into the radio when needed. The keyboard is operated by touchscreen or by using the CURSOR/SELECT hand control switch to select letters.

The 6.5 radio supports a full size keyboard and a large keyboard. See SYSTEM SETTINGS, Keyboard (6.5 Only) to select the keyboard type. The 4.3 radio uses a screen similar to the full keyboard for entering data.

The large keyboard may be more suitable for use when wearing riding gloves. When using the keyboard, some letters may be blanked out. This is a feature of the smart speller, which only enables valid strings of letters according to the entries in the database.

Input is displayed in the title bar. Select the buttons for numbers, symbols or extended characters to display keypads with additional characters as needed. When finished with a keyboard entry, select OK.

**Full Keyboard:** See Figure 21. When input is required, the screen displays a full keyboard with alphabetically arranged characters A-Z.

**Large Keyboard:** See Figure 22. When input is required, the screen displays a keypad with larger buttons. Use the keypad selectors on the right side to display different portions of the alphabet (A-I, J-R or S-Z).

om02026



1. Input (displayed in title bar)
2. Keyboard (alphabetically arranged)
3. Numeric keypad
4. Symbols
5. Extended characters
6. Backspace/delete
7. Space
8. OK/Enter
9. Shift (upper/lower case)

Figure 21. Full Keyboard

om02037

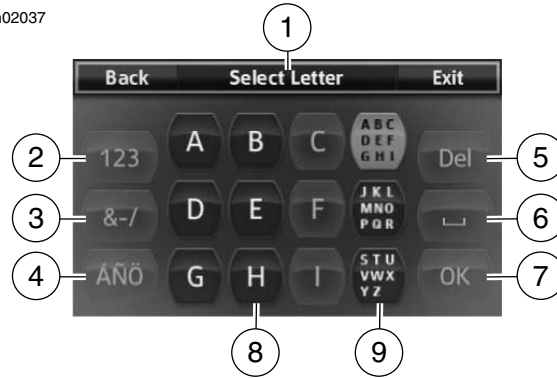

1. Input (displayed in title bar)
2. Numeric keypad
3. Symbols
4. Extended characters
5. Keypad
6. Keypad selectors (A-I, J-R, S-Z)
7. Backspace/delete
8. Space
9. OK/Enter

Figure 22. Large Keyboard



## SMART SPELLER

The smart speller assists you when entering information into the radio. When entering information (such as a search for a navigation address), the keyboard only enables strings of letters that match the entries in the database.

After a number of letters have been entered, the system will predict the word or location that you are trying to enter by providing matching data from the database. For example, entering "ROCH" could cause the system to suggest "ROCHESTER".

The smart speller can also accept partial entries. If pressing OK with only a partial string of text, the radio will provide a list of items that begin with that text. For example, entering "SAN" and pressing OK could provide a list including "SAN FRANCISCO" and "SANTA ANA".

The smart speller can also assist when entering multiple words. Entering the first few letters of each word, separated by a space, will cause the system to respond with matching words. For example, entering "N D" (including space) could cause the system to respond with "NORTH DAKOTA".

## VOLUME CONTROLS

A volume indicator is shown when the rider or passenger presses the volume control switch.

**Rider (controls on handlebar):** Adjusts the volume level for the speakers and the rider headphones (if active).

**Passenger (on Tour-Pak equipped models):** Adjusts the volume level for the passenger headphones only.

If the volume controls are pressed during a prompt or a specific function (such as during voice recognition, navigation prompt, CB or intercom activity), the volume for that particular function will be changed and displayed on the screen.



Figure 23. Adjusting Headset Volume

## POPUP SCREENS

The radio displays popup screens to explain when a feature is unavailable, display a low fuel message, indicate an incoming phone call, and so on. These screens may interrupt normal system operation. Some screens require a choice (Yes/No) or require confirmation (OK). Press the button to acknowledge the message or activate the feature.

## LOCKOUT SCREENS

Some screens, features or menu items may be locked out or unavailable, such as when the vehicle is in motion.

To operate the features, follow the guidance that is provided on the popup screen. If necessary, use hands-free voice recognition commands or safely park the vehicle to perform the task.









## STATUS BAR

See Figure 24. The status bar is at the bottom of most screens. It displays the clock and status icons. The icons are informational and are not selectable.











Figure 24. Status Bar









**Table 9. Status Bar Icons**

ICON	NAME	FUNCTION
	Speakers not muted	Icon is displayed when music/media audio is being routed to the speakers and speakers are not muted.
	Speakers muted	Icon is displayed when music/media audio is being routed to the speakers and speakers are muted.
	Headsets not muted	Icon is displayed when music/media audio is being routed to the headsets and the rider headset is not muted.
	Headsets muted	Icon is displayed when music/media audio is being routed to the headsets and the rider headset is muted.
	Traffic Announcement	<b>Select Markets Only:</b> The tuned RDS station is actively broadcasting an audio traffic announcement.
	Traffic Program	<b>Select Markets Only:</b> The tuner is set to an RDS station that regularly broadcasts traffic bulletins.
	SiriusXM Signal Strength	<b>If Equipped:</b> Number of filled bars indicates XM signal strength.
	Intercom microphone idle	<b>If Equipped:</b> Icon (white letters on a black background) is displayed if there is not an active microphone transmission.







**Table 9. Status Bar Icons**

ICON	NAME	FUNCTION
	Intercom microphone active	<b>If Equipped:</b> Icon (black letters on a white background) is displayed during an active microphone transmission.
	Harley-Davidson Bar & Shield	The Bar & Shield is always displayed in the center of the status bar.
	Citizen Band (CB) idle	<b>If Equipped:</b> Icon (white letters on a black background) is displayed if there is not an active CB transmission.
	CB active	<b>If Equipped:</b> Icon (black letters on a white background) is displayed during an active CB transmission.
	Bluetooth®	Icon is displayed when a Bluetooth device is connected and only when the system is not presenting one of these statuses: Roaming, New Messages, Low Battery or Phonebook icons.
	Roaming	Icon is displayed when a Bluetooth-connected phone is in a roaming area.
	New Messages	Indicates an SMS text message (if supported) has been received through a Bluetooth-connected phone.
	Low Battery	Icon is displayed when a Bluetooth-connected phone has a low battery.

**Table 9. Status Bar Icons**

ICON	NAME	FUNCTION
	Phonebook	Icon is displayed when a Bluetooth-connected hands-free device is downloading phonebook data. When download is complete, icon will disappear.
	Voice Recognition active	<b>If Equipped:</b> The icon will be displayed until the voice command has been executed or cancelled by holding the Voice Recognition switch.
	Voice Recognition not ready	<b>If Equipped:</b> The voice recognition system requires time after powering up to activate. This icon is displayed during the inactive period.
	Media paused	Icon is displayed when media audio is paused. Pressing Power/Mute will pause or un-pause the audio. Other events, such as receiving a phone call will pause media playback.
	Scan up	Icon is displayed during scan up operation of tuner or media.
	Scan down	Icon is displayed during scan down operation of tuner or media.
	Seek up	Icon is displayed during seek up operation of tuner or media.
	Seek down	Icon is displayed during seek down operation of tuner or media.

**Table 9. Status Bar Icons**

ICON	NAME	FUNCTION
	Phone Signal Strength	Number of filled bars indicates phone signal strength.
	North (direction)	<b>If Equipped:</b> Icon is displayed when the Navigation system has determined the vehicle is traveling north.
	South (direction)	<b>If Equipped:</b> Icon is displayed when the Navigation system has determined the vehicle is traveling south.
	East (direction)	<b>If Equipped:</b> Icon is displayed when the Navigation system has determined the vehicle is traveling east.
	West (direction)	<b>If Equipped:</b> Icon is displayed when the Navigation system has determined the vehicle is traveling west.
	Northeast (direction)	<b>If Equipped:</b> Icon is displayed when the Navigation system has determined the vehicle is traveling northeast.
	Northwest (direction)	<b>If Equipped:</b> Icon is displayed when the Navigation system has determined the vehicle is traveling northwest.

**Table 9. Status Bar Icons**

ICON	NAME	FUNCTION
<b>SE</b>	Southeast (direction)	<b>If Equipped:</b> Icon is displayed when the Navigation system has determined the vehicle is traveling southeast.

**Table 9. Status Bar Icons**

ICON	NAME	FUNCTION
<b>SW</b>	Southwest (direction)	<b>If Equipped:</b> Icon is displayed when the Navigation system has determined the vehicle is traveling southwest.

## NOTES

## SYSTEM SETUP

Configure the system settings before riding the motorcycle, with the motorcycle stationary and set to accessory mode. Adjust the options to match your personal riding style, and to make best use of any features or devices that you may be using. If there are problems with any features in the radio, first check the relevant settings.

Most settings are similar for all radios. However, some features or selections may be unique or unavailable on some vehicles. Some settings may also be specific for particular countries or regions. See FEATURES AND SPECIFICATIONS for more information about the features available on your motorcycle and in your region.

If audio accessories have been added to the motorcycle, see the instruction sheets for proper configuration and operation of those accessories.

### SETUP MENU

See Figure 25. Select **Home** > **Setup**. Table 10 shows a list of all the categories that can be configured. Some of the settings may be disabled or not displayed, depending on the radio type and region.



Figure 25. Setup Menu

**Table 10. Setup Menu**

ITEM	SETTINGS
Speaker/Headset	Music/Media Communication Prompts
Audio Setup	Bass Treble Fade Speed Volume
Display	Screen Brightness Button Brightness Colors (Day/Night Color Mode, Background Color*)
Global Presets	Global Presets On/Off Number of Pages
Full/Large Keyboard*	---
Feedback Settings	Prompt Volume Beep volume Nav Prompts (On/Off)
Bluetooth Setup	Bluetooth On/Off List Paired Devices (Add New Device) Ring Tones
English Units/Metric	---
Clock	User Time/GPS Time 12 Hour/24 Hour Daylight Savings Time (DST) On/Off Zone (Auto) or varied by region

**Table 10. Setup Menu**

ITEM	SETTINGS
SiriusXM Setup*	Subscription (Radio) Subscription (Specialty Services)
Traffic*	Traffic On/Off Re-route (Off/Auto/Manual) Notification
Navigation Setup*	Route Calculation Appearance
Rear Controls On/Off*	---
System Information	Software Hardware EQ Navigation
Language	English (US) English (UK) French (CA) French (FR) German (DE) Italian (IT) Spanish (ES) Spanish (MX) Portuguese (PT)
Classic Mode On/Off*	---
*Features are only available or enabled on some vehicles or regions.	



## LANGUAGE

See Figure 26. The system can be configured for any of the languages shown in Table 11. The selected language affects the text displayed on the screen, voice prompts from the system, and voice recognition features. To make sure that the system works properly for your use, select the proper language and dialect as applicable.



Figure 26. Language Setting

Table 11. Language Settings

SETTING	LANGUAGE/REGION
English (US)	American English
English (UK)	British English
French (CA)	Canadian French
French (FR)	France
German (DE)	Germany
Italian (IT)	Italy
Spanish (ES)	Castilian Spanish (Spain)
Spanish (MX)	Mexican Spanish
Portuguese (PT)	European Portuguese (Portugal)

## SCREEN BRIGHTNESS

1. See Figure 27. Select **Home > Setup > Display > Screen Display**.
2. **Automatic:** Check the **Automatic** checkbox. The screen brightness will automatically adjust according to the ambient light measured by the sensor in the speedometer.  
**Manual:** Uncheck the **Automatic** checkbox. Adjust the brightness level.



Figure 27. Display Feature

## BUTTON BRIGHTNESS

1. See Figure 28. Select **Home > Setup > Display > Button Brightness**.
2. Adjust the brightness level.

## NOTES

- *The brightness settings do not affect the brightness of vehicle instruments, illuminated hand control switches (on select models) or other accessories.*
- *The faceplate button lighting remains off when the radio is in Day Colors mode.*



Figure 28. Button Brightness

## DAY/NIGHT COLORS MODE

1. Select **Home > Setup > Colors**.

2. Press the multiselect button until the desired color mode is displayed.

**Day Colors:** Screen shows brighter colors.

**Night Colors:** Screen shows darker subdued colors. Navigation map is also shown in night color scheme. No other background colors can be selected while in night color mode.

**Automatic Colors:** Screen automatically adjusts day/night color modes according to ambient light measured by the sensor in the speedometer.



Figure 29. Colors

## BACKGROUND COLOR (6.5 ONLY)

1. See Figure 30. Select **Home > Setup > Colors > Backgrounds**.
2. Select one of the listed colors or Default (orange).



Figure 30. Backgrounds

## ENGLISH UNITS/METRIC

1. Select **Home > Setup**.
2. Press the multiselect button until the desired unit type is displayed.

**English Units:** Measurements are displayed as miles, yards, feet, MPH, gallons, degrees F and PSI.

**Metric:** Measurements are displayed as kilometers, meters, KPH, liters, degrees C and bar.

*NOTE*

*The English unit/metric selection also affects how units are displayed in the odometer.*

## CLOCK

1. See Figure 31. Select **Home > Setup > Clock**.
2. **12/24 hour:** Select 12-Hour or 24-Hour clock mode.
3. Press the multiselect button to choose GPS, RDS or User Time.

**GPS:** Automatically synchronizes the clock with data from incoming GPS signals. GPS time is only available on radios with navigation.

**RDS:** Automatically synchronizes time with radio stations broadcasting RDS data. RDS is only available on radios manufactured for select regions that support RDS operation.

**User Time:** Time is manually entered.

4. **Time zone:** Select the time zone. For GPS time, AUTO causes the clock to adjust to the time zone for the vehicle location. The clock updates as the motorcycle passes into other time zones.
  5. **Daylight savings time (DST):** GPS time does not automatically account for daylight savings time. For GPS or user time, select **DST On** to advance the clock one hour (during spring in the northern hemisphere). Select **DST Off** to return to the original time.
  6. **Manually adjusting time (User Time selected):** Manually adjust the clock to the current time with the + and - controls.
- Manually adjusting time (GPS Time selected):** An offset can be applied to the GPS time. The offset is shown next to the time setting.



Figure 31. Clock Settings

## KEYBOARD (6.5 ONLY)

1. See Figure 32. Select **Home** > **Setup**.
2. Select **Full Keyboard** (which displays all characters) or **Large Keyboard** (which displays a larger keypad). See BASIC OPERATION, Keyboard for keyboard types.



Figure 32. Keyboard Setting (Full/Large)

## SPEAKER/HEADSET SELECTION

1. See Figure 33. Select **Home** > **Setup** > **Speaker/Headset**.
2. For each category shown, select whether the audio routes through the headsets or speakers.

**Music/Media:** Tuner stations, SiriusXM channels and media files.

**Communication:** CB, intercom and phone.

**Prompts:** Voice recognition, navigation prompts, text-to-speech and other audio feedback from the radio.



Figure 33. Speaker/Headset Selection



Figure 34. Audio Setup Screen

## AUDIO SETTINGS (BASS/TREBLE)

1. See Figure 34. Select **Home > Setup > Audio Setup**.
2. Adjust the Bass and Treble settings using the + and - controls. The tone settings are applied for all audio output through the speakers and headsets.

## FADE

The fade setting adjusts the balance of volume between the front and rear speakers. By default, the fade is set at the center with an equal balance of volume. Some vehicles have a fade adjuster as shown in Figure 35. Other vehicles have a graphical fade adjuster as shown in Figure 36.

The fade setting does not affect headset or microphone audio levels. Fade does not apply to models without rear speakers.

1. Select **Home > Setup > Audio Setup**.
2. Select **Fade/Speed Volume**.

- Adjust the front to rear fade.

**Fade adjustment (typical):** Press the R (rear) or F (front) controls to adjust the balance of the speaker volume between the front and rear speakers. The center circle indicates an equal balance of volume to both front and rear speakers.

**Graphical fade adjustment (select models):** Adjust the front to rear sound balance by pushing left or right cursor controls. The fade adjustment line displays the balance of sound between the front and rear speakers. The center dashed line represents the equal balance of volume for front and rear speakers.



**Figure 35. Fade/Speed Volume Adjustment Screen**

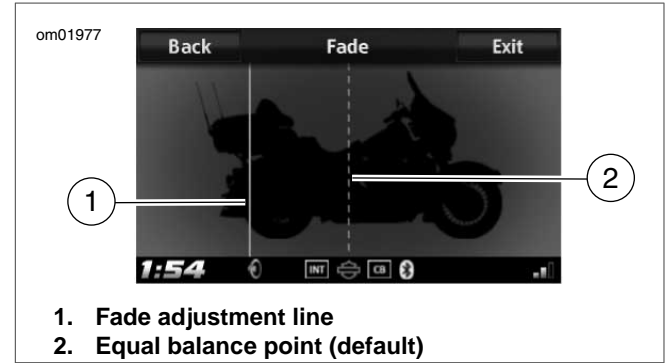

- Fade adjustment line
- Equal balance point (default)

**Figure 36. Graphical Fade Adjustment (select models)**

## SPEED VOLUME

The speed volume setting adjusts the volume according to vehicle speed. This function allows the volume to be set to a comfortable level while the motorcycle is stopped or traveling slowly. The volume automatically increases to compensate for engine, wind and other ambient noise factors as vehicle speed increases.

The speed volume setting also affects the voice activation (VOX) of the intercom. This prevents ambient noise from

activating VOX transmissions when at greater speeds. It also prevents the need to continually adjust the VOX sensitivity setting.

Speed volume is also known as automatic volume control (AVC) on previous Harley-Davidson sound systems.

1. Select **Home > Setup > Audio Setup**.
2. See Figure 35. Select **Fade/Speed Volume**.
3. Adjust speed volume to one of four different levels. Each level defines the amount of gain that is added to the volume as vehicle speed increases.

#### NOTES

- *Setting speed volume to the lowest level effectively turns off this feature. The volume remains constant while riding. However, the radio has equalizers with dynamic filters which modify certain frequency bands depending on speed. So there may still be a change in sound as the speed changes, even with speed volume turned off.*
- *The effects of the speed volume will be less noticeable under certain conditions, such as when the volume is already turned up near its maximum setting.*

## FEEDBACK (PROMPTS)

The prompt volume affects audible feedback, such as navigation prompts, voice recognition prompts, text-to-speech features and so on. Prompt volume can also be adjusted by the volume hand controls while the prompt is playing.

1. See Figure 37 Select **Home > Setup > Feedback**.
2. **Prompt volume:** Adjust prompt volume.
3. **Navigation prompts:** Check the **Enable Nav Prompts** checkbox to enable audible navigation guidance. Uncheck to turn this feature off.
4. **Beep volume:** Adjust beep volume.



Figure 37. Feedback Settings



## REAR CONTROLS

1. See Figure 38. Select **Home** > **Setup**.
2. Select the **Rear Controls** checkbox.

**Checked:** All passenger controls on the side of the Tour-Pak function normally.

**Unchecked:** The passenger volume and PTT controls continue to operate normally. However, the MODE/UP/DN switch is disabled. The passenger cannot change audio sources or tune/seek to other channels or songs.



Figure 38. Rear (Passenger) Controls

## CLASSIC MODE

When Classic Mode is selected, the HOME hand control switch will toggle through available audio sources, rather than displaying the Home screen. This operates similar to the MODE SEL switch on previous Harley-Davidson motorcycles. For example, repeatedly pressing the HOME switch on the handlebar will toggle through tuner bands (AM, FM, WB and so on) and through media devices.

To display the Home screen while in Classic Mode, press and hold the HOME hand control switch or use the HOME switch on the radio faceplate.

1. See Figure 39. Select **Home** > **Setup**.
2. Check the **Classic Mode** checkbox to enable.



Figure 39. Classic Mode Setting

## GLOBAL PRESETS

The global preset feature shows a common set of presets for all audio sources. Presets for all tuner band stations (AM, LW, MW, FM, WB), media files and SiriusXM channels are commonly displayed on all audio source screens. This allows easier access to the most commonly used channels and media, without having to manually change to different devices or audio sources. When enabled, the system supports up to 20 global presets.

When global presets are not enabled, each tuner band or media device will only display its own unique presets. The total

number of presets is different when global presets are not enabled. CB channels, phone contacts and navigation destinations cannot be stored as global presets. See TUNER, Presets for more information.

1. See Figure 40. Select **Home > Setup > Global Presets**.
2. **Enable/disable global presets:** Check (or uncheck) the **Enable** checkbox.
3. **Set pages:** Refer to Table 12. Select up to four pages of global presets.
4. **To set a global preset:** Select the desired audio source (tuner station, media file or SiriusXM channel). Press and hold the desired preset button to store the new preset.  
**To select a global preset:** While displaying any audio source, select the desired preset. The system changes to the necessary band or media device to play the selected preset.



Figure 40. Global Presets



Figure 41. Global Preset Example (Multiple Preset Types On Page)

Table 12. Global Presets (Page Setting)

PAGES	TOTAL PRESETS
1 page	6 presets
2 pages	10 presets
3 pages	15 presets
4 pages	20 presets

## BLUETOOTH

See BLUETOOTH and other applicable sections for configuration and operation of Bluetooth devices.

## RING TONES

See PHONE, Selecting Ring Tone for setting up or installing a new ring tone.

## SIRIUSXM

See SIRIUSXM for setting up and subscribing to SiriusXM on equipped vehicles.

## TRAFFIC

See NAVIGATION, Traffic to set up and operate traffic features.

## SYSTEM INFORMATION

1. Select **Home > Setup > System Information.**
2. Select the information to display.

**Software:** See Figure 42. Shows the current software version installed on the radio. Software updates are available on [www.h-d.com/boom](http://www.h-d.com/boom) (or the Boom! Box portion of [www.h-d.com/touring](http://www.h-d.com/touring)). See SYSTEM SETTINGS, Software Update for instructions.

**Hardware:** See Figure 43. Shows the Harley-Davidson part number, supplier part number and a unique serial number for the radio. Use the Harley-Davidson part number along with the information in FEATURES AND SPECIFICATIONS to determine the features available on this radio.

**EQ:** Shows the equalizer (EQ) file installed in the radio. This is based on the vehicle, fairing type and speaker configuration. The EQ may be updated by the dealer when adding new accessory speakers to the motorcycle.

3. Select **Navigation.**
4. Select the navigation information to display.

**Software:** Shows the current software version for the navigation software engine.

**Database:** See Figure 44. Shows the current map database version that is installed in the radio.

**Export for Update:** Used when updating or purchasing new map sets. See NAVIGATION, Navigation Database to install or update maps.



Figure 42. Software Version



Figure 44. Navigation Database Version

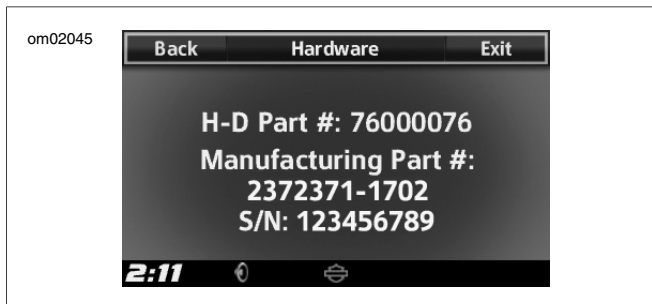

Figure 43. Hardware Information

## SOFTWARE UPDATE

Harley-Davidson periodically provides software updates for the radio on [www.h-d.com/boom](http://www.h-d.com/boom). Check if you are using the latest version of software and update the software when a newer version is available. Updates can be done by using the following procedure, or by bringing the vehicle to an authorized Harley-Davidson dealer.

1. See Figure 42. Select **Home** > **Setup** > **System Information** > **Software**.

2. Compare the software version in the radio with the latest version of software available on [www.h-d.com/boom](http://www.h-d.com/boom) (or the Boom! Box portion of [www.h-d.com/touring](http://www.h-d.com/touring)).
3. **Versions are the same:** You have the latest software available. There is no need to update.  
**Higher software level is available on website:** Continue with procedure to update your radio software.

*NOTE*

*Do not interrupt the installation process. Leave the vehicle and radio turned on, and keep the USB drive installed until the installation process is complete.*

4. Download the latest software version from the website. Select the proper update for your radio type (4.3, 6.5 or 6.5 CVO) and the proper region/vehicle configuration, if applicable.
5. Copy the zipped folder to the root directory (the first or top directory) of a USB drive. Some updates may require up to an 8 GB USB drive.
6. **Keyed ignition motorcycle:** Turn the vehicle ignition switch to ACCESSORY.  
**Keyless ignition motorcycle:** With the vehicle turned off, press and hold the trigger switch until the vehicle enters accessory mode.

7. Turn on the radio.
8. Connect the USB drive to the vehicle USB port. The radio will detect the new software and prompt for the update.
9. See Figure 45. Select **Yes**. The software installation begins. The display will prompt to remove the USB drive when the update is complete.

*NOTE*

*If the incorrect file is on the USB drive, the radio will display the error message "The ISO image on the attached USB is corrupt or incompatible".*



**Figure 45. Software Update**

## PRIVACY RESET

A privacy reset can be performed by the dealer to remove all personal information from the radio memory. This can be useful when selling the motorcycle or when completely reconfiguring the radio with new personal settings. The reset will remove information and history from the radio such as phone pairing, downloaded phone books, call history, navigation history, favorites and presets. A privacy reset does not affect other

basic settings like the clock or audio configuration. See an authorized Harley-Davidson dealer to have this service performed.

## FACTORY RESTORE

A factory restore can be performed by the dealer to restore the radio to its original factory settings. This removes all user settings in radio. See an authorized Harley-Davidson dealer to have this service performed.

## NOTES



## FAVORITES

The system stores up to six favorites, plus an additional favorite for the FAV switch on the radio faceplate. Favorites can be used to quickly access a tuner band, frequency, media device, media file or SiriusXM channel that is commonly used.

Navigation destinations, phone contacts, CB channels and files from a Bluetooth-connected device cannot be saved as favorites.

## SETTING A FAVORITE

1. Tune to a radio station, weather band channel, SiriusXM channel or file from USB-connected device.

2. **Store to FAV switch (on radio faceplate):** Press and hold the FAV switch.

**Store to Favorite screen:** Select **Home** > **Fav**. Press and hold one of the favorite preset buttons from the list.

3. See Figure 46. Select one of the following from the list:  
**Currently playing audio source:** Shown at the top of the list.

**Tuner:** Sets the favorite to a selected tuner band (AM, FM, WB, LW or MW as applicable).

**Media:** Sets the favorite to a USB-connected device.

**Satellite:** Sets the favorite to SiriusXM tuner.

## NOTE

*The tuner, media and satellite options only set the favorite to the selected device, rather than to a particular station or media file.*



Figure 46. Setting a Favorite

## SELECTING A FAVORITE

If selecting a file from a removable media device, the radio will do nothing unless the media device is connected.

**FAV switch (on radio faceplate):** Briefly press FAV switch to select the audio source.

**Favorite screen:** See Figure 47. Select **Home** > **Fav.** Select a favorite from the list.



**Figure 47. Favorites List**

## TUNER

The radio has a multi-band stereo receiver with tune, seek and scan functions. The tuner supports RDS or RBDS data display (according to vehicle configuration). The tuner can be configured to search for particular program types (such as country

music or news programming). In some radios, the system can accumulate a list of stations within range, along with the current song or program being played.

See Figure 48 for a description of the Tuner screen components. See FEATURES AND SPECIFICATIONS for features supported for your vehicle or region.

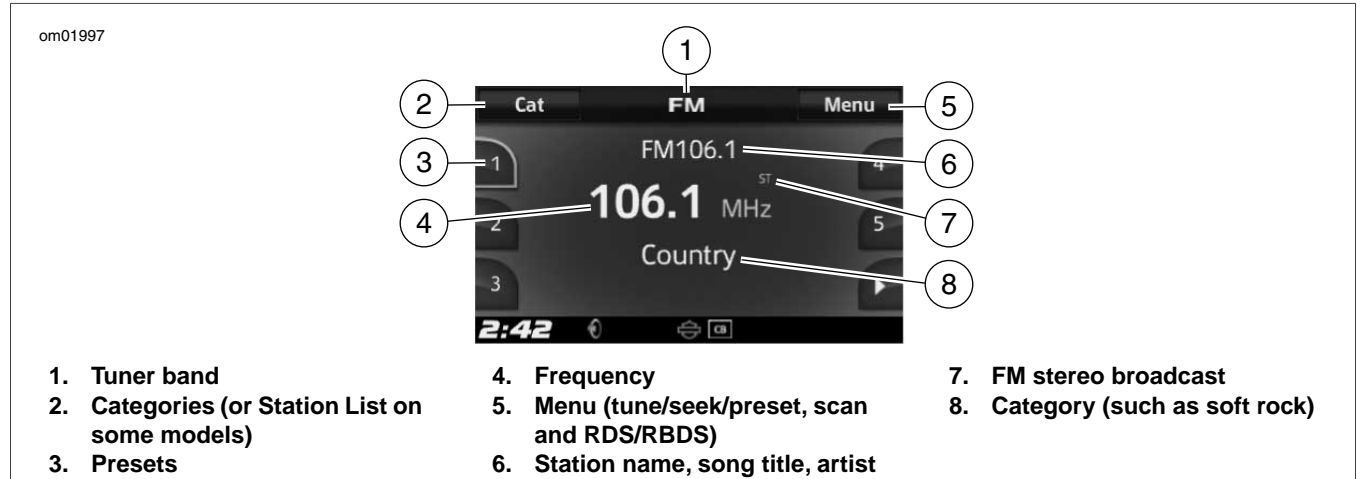

Figure 48. Tuner Screen

## SELECTING A BAND (MENU BUTTONS)

Radios support different frequency bands according to region and radio type. See FEATURES AND SPECIFICATIONS.

1. Select **Home > Tuner**.
2. Select the desired band (AM, LW, MW, FM or WB, as applicable).

## SELECTING A BAND (HOME HAND CONTROL, CLASSIC MODE)

When Classic Mode is enabled, repeatedly press the HOME hand control switch to rotate through all available bands and audio sources.

## SELECTING A BAND (VOICE RECOGNITION)

1. Press the VOICE RECOGNITION switch.
2. Speak the band into the microphone (**AM**, **FM**, **WEATHER BAND**, **MEDIUM WAVE** or **LONG WAVE**).

## TUNE/SEEK/PRESET SETTINGS

The PREVIOUS/NEXT hand control switch can be configured to tune, seek or select the next preset in the tuner.

When tuning or seeking, the tuner will continue to wrap around at the beginning or end of the frequency range.

1. With a tuner band displayed, select **Menu**.
2. See Figure 49. Press the Tune/Seek/Preset multiselect button until the desired function is displayed.

**Tune:** The PREVIOUS/NEXT hand control switch will advance to the next frequency increment. Holding the PREVIOUS/NEXT switch will accelerate through frequencies.

**Seek:** The PREVIOUS/NEXT hand control switch will seek the next station. Holding the switch will accelerate through the frequencies. The tuner then seeks the next available station upon releasing the switch.

**Preset:** The PREVIOUS/NEXT hand control switch will select the previous or next preset.



Figure 49. Tuner Menu

## TUNING A STATION (HAND CONTROL SWITCH)

When configured for tuning, use the PREVIOUS/NEXT hand control switch to advance to another frequency.

**Short press:** Advances to the next frequency increment.

**Long press:** Accelerates through the frequencies until the switch is released.

## TUNING A STATION (VOICE RECOGNITION)

1. Press the VOICE RECOGNITION switch.
2. Say **TUNE TO** along with the frequency into the microphone (such as **TUNE TO NINETY-SEVEN POINT ONE**). The radio automatically tunes to the appropriate band (such as AM or FM) according to the frequency selected.

## SEEKING A STATION (HAND CONTROL SWITCH)

When configured for seeking, use the PREVIOUS/NEXT hand control switch to find the next station.

**Short press:** Seeks the next station. The seek icon is displayed in the status bar.

**Long press:** Accelerates through the frequencies. The tuner then seeks the next available station upon releasing the switch.

## SEEKING A STATION (VOICE RECOGNITION)

1. Press the VOICE RECOGNITION switch.
2. Speak **SEEK UP** or **SEEK DOWN** into the microphone.

## SCANNING STATIONS

1. With a tuner band displayed, select **Menu**.
2. Select **Scan**. The radio begins scanning through the frequencies. The radio dwells on each station for five seconds before continuing the scan. The scan icon is shown in the status bar during this process. If the scan does not find any strong station within two complete passes through the band frequencies, the scan automatically cancels.
3. To select a station, press the CURSOR/SELECT switch on the right hand controls.

## PRESETS

Presets can store preferred radio stations for easy access. The radio has 15 presets for FM band, and 6 presets for other bands. The radio can also be configured with global presets. See SYSTEM SETTINGS, Global Presets.

1. Tune to a station.
2. Press and hold one of the preset buttons until a beep sounds. The frequency is stored to the selected preset button.
3. To tune the preset in the future, select the preset button.

## CATEGORIES (CAT)

The FM band can be configured to seek or scan for particular types of radio programming (such as news, sports or classical music). When categories are selected, the radio only seeks or scans for the stations that are broadcasting programs with the selected category codes. Not all stations broadcast these codes. When categories are selected, the FM band displays CATEGORIES with a filter symbol as shown in Figure 50.

Categories are also known as program types (PTYs).



Figure 50. Categories Symbol

## SELECTING CATEGORIES

See Table 13 for categories available in North America. See Table 14 for categories available in other regions.

1. While in the FM band, select **Cat** to access a list of all available categories. For some radios, the Categories button is on the Stations screen.
2. See Figure 51. Select categories from the list.

**Individual categories selected:** Radio seeks or scans only stations from the selected categories. The FM screen shows the category filter icon.

**Clear All (or no categories selected):** Radio seeks or scans all stations.

**Select All:** Radio seeks or scans stations which are broadcasting any of the program types. The radio will not

stop at any station unless it is broadcasting a program type code. The FM screen shows the category filter icon.

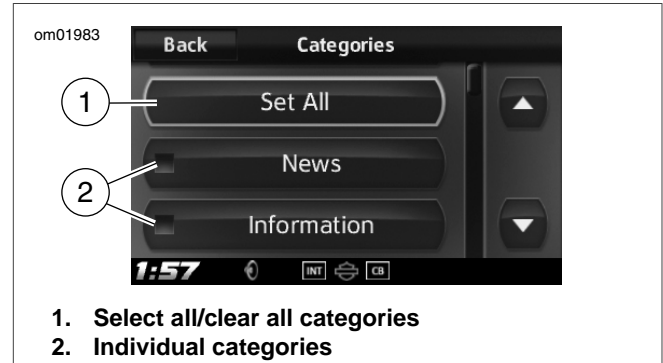

Figure 51. Setting Categories

**Table 13. FM Categories (RBDS, North America)**

OPTION	OPTION
• Set/Clear All	• Nostalgia
• News	• Jazz
• Information	• Classical
• Sports	• Rhythm & Blues
• Talk	• Soft Rhythm & Blues
• Rock	• Foreign Language
• Classic Rock	• Religious Music
• Adult Hits	• Religious Talk
• Soft Rock	• Personality
• Top 40	• Public
• Country	• College
• Oldies	• Weather
• Soft	

**Table 14. FM Categories (RDS, Other Regions)**

OPTION	OPTION
• Set All	• Other Music
• News	• Weather
• Current Affairs	• Finance
• Information	• Children's Programmes
• Sport	• Social Affairs
• Education	• Religion
• Drama	• Phone-in
• Culture	• Travel
• Science	• Leisure
• Varied	• Jazz Music
• Pop Music	• Country Music
• Rock Music	• National Music
• Easy Listening	• Oldies Music
• Light Classical	• Folk Music
• Serious Classical	• Documentary

## STATION LIST

Radios equipped with the station list feature will have a Stat button in the upper left corner on the FM screen. The radio scans and creates a list of all available stations in the FM band. Radios with a dual tuner will continually update the list as stations come in and out of range.



**Accessing station list:** See Figure 52. For equipped radios, press the **Stat** button in the upper left corner of the FM band screen.

**Selecting a station:** See Figure 53. Use the scroll controls. Select the desired station from the list.



Figure 52. FM Tuner (Station List)



1. Stations (showing current station or program information)
2. Categories

Figure 53. Station List

## WEATHER BAND

Weather band is supported on radios for North America. Equipped radios can tune to any of the seven weather band frequencies. The six weather band presets are originally set to the first six weather band frequencies.

In the US, the National Oceanic and Atmospheric Administration (NOAA) operates National Weather Radio (NWR) stations across the country. These stations continually broadcast

weather announcements using the seven different frequencies designated for weather band use as shown in Table 15.

In Canada, Weatherradio Canada broadcasts weather information on the same set of frequencies.

**Listen to weather band:** Select **Home > Tuner > WB**.

**Tune to weather band frequency:** Use the PREVIOUS/NEXT hand control switch to advance through the seven weather band frequencies.

**Using weather band presets:** Refer to Table 15. Select preset (1-6).

**Changing weather band preset:** Tune to a weather band frequency. Press and hold a preset to store the channel.

**Table 15. Weather Band Channels**

PRESET	CHANNEL	FREQUENCY
1	WB1	162.400 MHz
2	WB2	162.425 MHz
3	WB3	162.450 MHz
4	WB4	162.475 MHz
5	WB5	162.500 MHz
6	WB6	162.525 MHz
N/A	WB7	162.550 MHz

## WEATHER ALERT

The weather band alert feature is only available on radios built for North America with a CB module.

When the weather alert feature is turned on, the CB module continuously scans the weather band for an alert tone from the weather band stations. The rider can continue to play media, listen to other stations or use other features on the radio. When an alert tone is detected, the radio changes to the weather band and tunes to the channel with the alert announcement. The alerts indicate extreme weather conditions such as tornados, storms, floods or other environmental warnings. See

www.weather.gov/nwr for weather band and alert broadcast information.

**Turn weather alert on:** See Figure 54. On weather band screen, press button in upper left corner to display **On**.

**Turn weather alert off:** On weather band screen, press button in upper left corner to display **Off**.



Figure 54. Weather Band Screen

## RBDS/RDS

Some radio stations broadcast data which can be used to display station identification, program information and support other features in the radio (depending on the region).

Radio Broadcast Data System (RBDS) is primarily used in North America. Stations broadcasting RBDS typically provide information such as radio station name, artist and song title to the radio.

Radio Data System (RDS) is primarily used in Europe. Stations broadcasting RDS data may also include time updates, weather, traffic and other regional information.

Not all radio stations transmit RBDS or RDS data. When RBDS or RDS is unchecked, or if the service is not available, only the radio frequency is displayed.

**Enable RDS/RBDS:** From FM tuner screen, select **Menu**. Check the **RDS** or **RBDS** checkbox.

## RDS Features

For dual tuner radios with RDS capability, three separate RDS features can be enabled.

**Alternate Frequency Switching (AF):** The radio monitors the signal strength of other stations playing the same program.

The radio automatically switches to another station if the signal quality is better.

**Regionalization (REG):** Some radio stations split their program into separate regional programs on different frequencies. Regionalization automatically uses frequencies of regional related stations for alternate frequency jumps.

**Traffic Program/Traffic Announcement (TP/TA):** The radio monitors stations for traffic announcements. When a traffic

announcement is discovered, the radio automatically tunes to the station playing the announcement. The Traffic Announcement icon (TA) is displayed in the status bar. When finished, the tuner returns to its previous operation. The status bar displays the Traffic Program (TP) icon when tuned to a station that regularly plays traffic announcements. When enabled, the radio also monitors stations for Enhanced Other Networks (EON) transmissions.



## MEDIA SCREEN

See Figure 55. The Media screen shows the status of the cur-

rent playing song. On 6.5 radios, the media screen also displays the cover art for the song, if available.

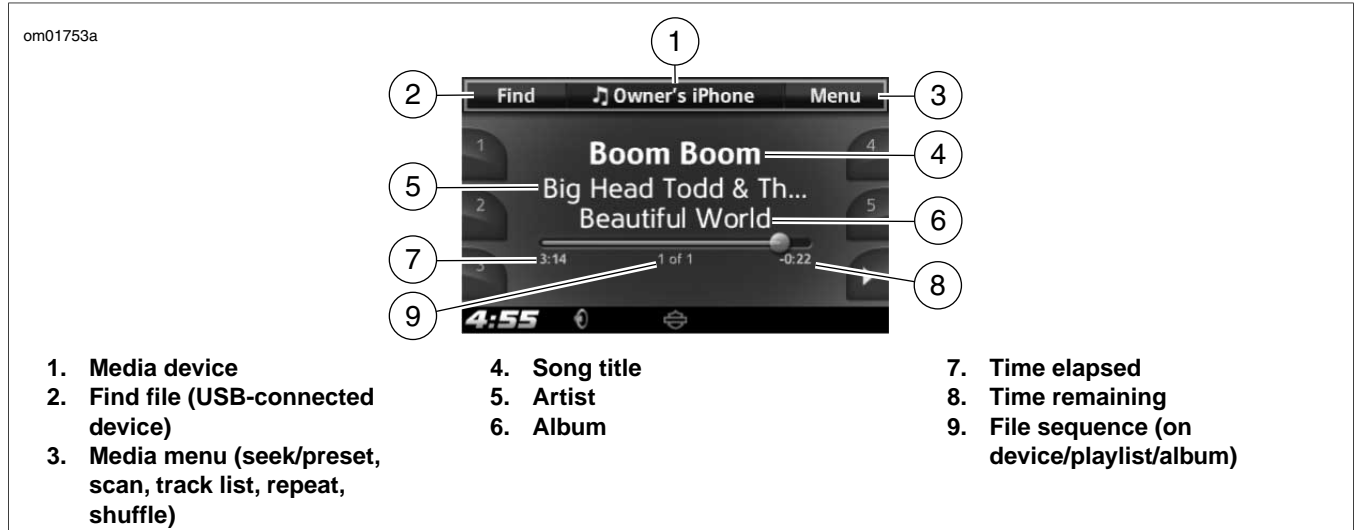

Figure 55. Media Screen

## MEDIA DEVICES

The radio supports various types of USB and Bluetooth-connected media devices. As a general guideline, support for devices is listed in Table 16. Some features or menus may not be available depending on device, file type or connection type.

For mass storage devices (such as USB drives), the file organization on the device can impact performance. For best performance and indexing of files, store media files at the root directory of the USB device, rather than in multiple levels of folders.

**Table 16. Media Device Support**

DEVICE	DEVICES SUP-PORTED	CONNECTIONS	FILES SUP-PORTED	FEATURES OR LIMITATIONS
iPod	iPod supporting iAP	Apple proprietary connector.	All iPod supported file types	Supports all find features. Ring tone files cannot be downloaded. iPods with a hard drive can be damaged and are not recommended.
USB mass storage device	USB drive (FAT16, FAT32, NTFS, HFS+) or SD card	Direct connection to USB port. USB connector and reader required for SD card.	MP3, MP4, MPEG-4 AAC, M4A, M4B, WAV, WMA	May support find features. NTFS-formatted drives can only be used for read-only functions (such as playing media). NTFS drives will not support functions like trip/trail exports or navigation database updates.

**Table 16. Media Device Support**

DEVICE	DEVICES SUPPORTED	CONNECTIONS	FILES SUPPORTED	FEATURES OR LIMITATIONS
Media player	USB-connected phone. PlaysForSure compatible device. Media Transfer Protocol (MTP) compatible device.	USB cable.	MP3, MP4, MPEG-4 AAC, M4A, M4B, WAV, WMA	May support find features.
Bluetooth device	Varies. Requires minimum Bluetooth profile interoperability.	A2DP/AVRCP profiles.	Bluetooth device dependent. Bluetooth audio is streamed by the device and not decoded by radio.	No find, browse, shuffle, track list, or preset capability. File metadata may not be displayed. Audio from an app or internal player can be streamed to radio.

## CONNECTING MEDIA DEVICE (USB)

1. Connect the media device to the USB port. Use a connector or reader as needed.
2. If the media device is not automatically recognized, check the device settings. Some devices need to be configured to connect as a hard drive or as a media device before media files can be accessed. See the device manual.

## NOTES

- *If connecting a new device, the radio begins playing the first song found on the device. If reconnecting a previously used device, the radio attempts to resume the last played file.*
- *The radio will begin collecting file information from the device. Some information and features may not be available until the radio has finished synchronizing with the device. The radio will play remaining files in alphabetical order.*

## CONNECTING MEDIA DEVICE (BLUETOOTH)

1. Pair the device. See **BLUETOOTH, Pairing a Bluetooth Device.**
2. Select **Home > Media.**
3. Select the device from the list.

## DEVICE PLAYERS AND APPLICATIONS (BLUETOOTH)

Streaming audio can be played from an internal player or application on a connected Bluetooth device. The radio can

control some features, such as previous or next file selections within some players or applications.

1. With motorcycle stopped, connect with the Bluetooth device.
2. Start the media application or internal player within the Bluetooth-connected device. The audio begins playing through the motorcycle speakers or headsets.
3. Use the **PREVIOUS/NEXT** hand control switch and **POWER/MUTE** switch on the radio faceplate to operate the application or internal player, as applicable.

## NOTE

*The volume level and equalization within the device can affect the streaming volume to the radio. If sound cannot be heard or is distorted, check the volume within the application or device.*

## SELECTING MEDIA DEVICE

1. See Figure 56. Select **Home > Media.** A list of paired or connected devices is displayed. Items are marked with either a USB or Bluetooth symbol.
2. Select device from the list. If connected, the first song from the device begins playing.





Figure 56. Selecting Media Device

## PLAY PREVIOUS/NEXT MEDIA FILE (OR PREVIOUS/NEXT PRESET)

Depending on the configuration, the PREVIOUS/NEXT hand control switch will either advance through each song individually, or through each preset that is programmed for the device.

1. Select **Home > Media > Menu**.

2. Press the multiselect button to show **Seek** (to advance through each song) or **Preset** (to advance through each preset).
3. Press the PREVIOUS/NEXT hand control switch to advance to the previous or next song (or preset) in the device.

## PAUSE, REWIND, OR FAST FORWARD MEDIA FILE

**Pause:** Press the POWER/MUTE switch to pause or unpause media.

**Rewind:** Press and hold PREVIOUS/NEXT switch to the left. Rewinding will accelerate as switch continues to be held.

**Fast Forward:** Press and hold PREVIOUS/NEXT switch to the right. Fast forwarding will accelerate as switch continues to be held.

## SCANNING MEDIA FILES

1. Select **Home > Media > Menu**.
2. See Figure 57. Select **Scan**. The radio begins playing each song on the device sequentially, dwelling on each song for five seconds. The Scan icon is displayed on the screen.

3. Press the **SELECT/ENTER** hand control switch to continue playing the current song.

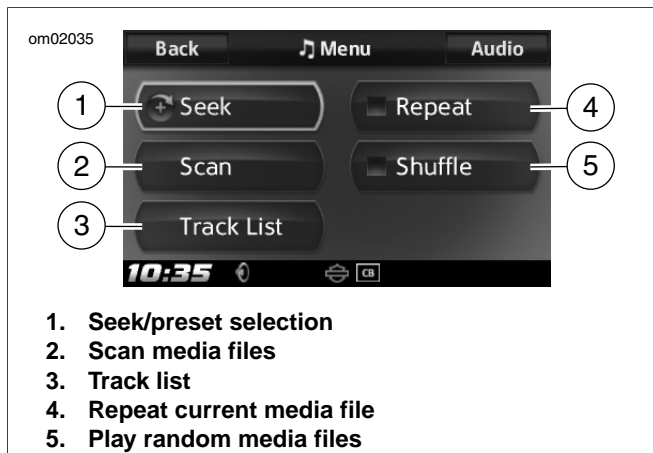

Figure 57. Media Menu

## REPEAT CURRENT FILE

1. Select **Home > Media > Menu**.

2. Check the **Repeat** checkbox. The Repeat icon is displayed and the current file will play repeatedly until unselected.

## PLAY RANDOM FILES (SHUFFLE)

1. Select **Home > Media > Menu**.
2. Check the **Shuffle** checkbox. The Shuffle icon is displayed. The radio will randomly select files from the device.

### NOTE

*An iPod may exclude audio books and podcasts from shuffle selection.*

## PLAY SONGS FROM TRACK LIST

The track list shows a full list of all songs on the connected device. When selecting a song from the list, the radio remains in the track list and does not transition back to the media screen. Track lists are not available for Bluetooth streaming media devices.

1. Select **Home > Media > Menu**.
2. See Figure 58. Select **Track List**. A complete list of all songs from the currently selected device, playlist, artist or album are displayed.
3. Select a song from the list to play.

4. Select the information button ("i") to display information for the selected song or the entire track list (such as the album for the currently displayed tracks).



Figure 58. Media Track List

## MEDIA PRESETS

The radio stores up to 20 presets for each connected device. The screen only shows media presets for the currently connected device. The media presets are retained in memory, and are available the next time the media device is connected. Presets are only available for USB connected devices.

**Set media preset:** With song playing, press and hold one of the presets. The radio beeps and the preset is stored.

**Select media preset:** Press desired preset. Song will begin playing.

**Seeking presets:** In the media screen, select **Menu**. Select **Presets**. The PREVIOUS/NEXT hand control switch will advance through each of the presets, rather than through every song on the device.

## FINDING A MEDIA FILE

See Figure 59. The Find feature can be used to browse for different types of media files on USB-connected media devices as shown in Table 17. File browsing features are not available for Bluetooth streaming media devices.

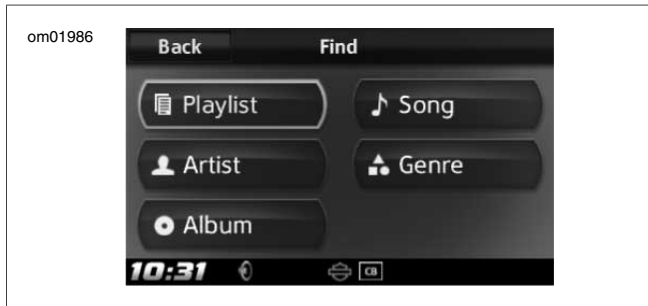

**Figure 59. Finding a Media File**

**Table 17. Finding a Media File**

CATEGORY	DESCRIPTION
Artist	Lists all songs by selected artist. Radio will play a selected song, then plays remaining songs by the artist.
Album	Lists all songs on selected album. Radio will play a selected song, then plays remaining songs on the album.
Genre	Lists songs by selected genre.
Song Title	Searches for song by title.
Playlist	List of all playlists on device.
Podcast	List of all podcasts on device (Apple devices only).
Audio Book	List of all audio books on device (Apple devices only).
Video, TV Show, Movie or Music Video	List of video files on device (only audio portion is played).

## FINDING A MEDIA FILE (PLAYLIST)

A playlist is a file stored on the device which includes a sequential list of songs. All playlists native to the iPod are supported. The radio also supports the following playlist types for other USB-connected devices.

- Windows Media Player Advanced Stream Redirector format (\*.asx)
- Windows Media Player Playlist (\*.wpl)
- M3U Moving Pictures Expert Group Audio Layer 3 Uniform Resource Locator (\*.m3u)
- PLS file (\*.pls)
- iTunes XML (\*.xml)
- RealPlayer Metadata Package (\*.rmp)

### NOTES

- *M3U, PLS and WPL playlists only allow relative pathnames to files. Absolute pathnames are not supported.*
  - *All XML files on USB mass storage media will be displayed, even if the files are not actually XML-formatted playlists.*
1. Select **Home > Media > Find**.

2. Select **Playlist**.
3. Select item from list.
4. Select song from the playlist. To play the entire playlist, select the first song.

## FINDING A MEDIA FILE (ARTIST, ALBUM OR GENRE)

1. Select **Home > Media > Find**.
2. Select **Artist, Album** or **Genre** to browse.
3. Select item from list.
4. Select song from the list. The radio will begin playing files for the artist, album or genre, starting at the selected file. To play all songs for this artist, album or genre, select the first song from the list.

## FINDING A MEDIA FILE (SONG TITLE)

1. Select **Home > Media > Find**.
2. See Figure 60. Select **Song**. A full list of all songs on the device is displayed.

3. Select a song from the list. If necessary, select the letter jump button between the scroll controls and type the first letter of the song name.



Figure 60. Finding a Media File (Song)

## FINDING A MEDIA FILE (PODCAST)

The Podcast category is displayed in the Find menu when a properly configured podcast is identified on the device. An audio file (ID3 tag) must be coded properly to display on the radio as a podcast. If needed, right-click on the file in iTunes

and select the proper option for characterizing the file (movie, music, video, podcast, and so on).

Some files identified as podcasts are not actually podcast files, but just media files. These files may be listed with other song files.

1. Select **Home > Media > Find**.
2. Select **Podcast**.
3. Select a podcast from the list.
4. See Figure 61. Select an episode from the list.



Figure 61. Podcast

## FINDING A MEDIA FILE (AUDIO BOOK)

The audio book option is displayed when audio book files have been discovered on the device. Some audio books are MP3 files which may be listed with other song files.

1. Select **Home > Media > Find**.
2. Select **Audio Book**. A list of audio books is displayed.
3. Select an audio book from the list.
4. See Figure 62. Select a chapter from the audio book, if applicable.

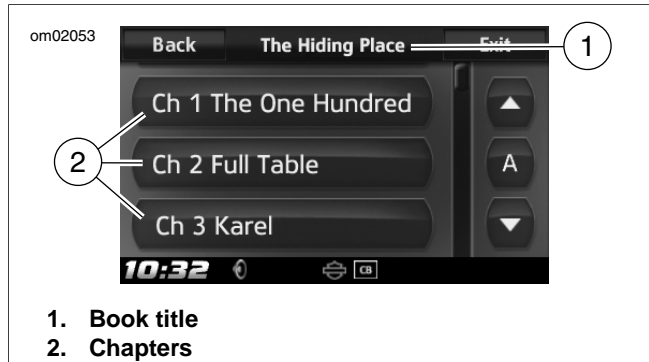

Figure 62. Audio Book

## FINDING A MEDIA FILE (VIDEO, TV SHOW, MOVIE, MUSIC VIDEO)

The radio can play some types of video files. To minimize distraction, the radio only plays the audio portion of the files.

Files from Apple devices may be categorized as TV Show, Movie or Music Video. Supported video files from a USB device are categorized as Video.

1. Select **Home > Media > Find**.
2. Select **Video, TV Show, Movie or Music Video**.
3. Select a file from the list. Audio from the video file will begin playing.

## SELECTING MEDIA FILE (USING VOICE RECOGNITION)

See VOICE RECOGNITION for detailed instructions on all voice recognition commands.

1. Press the VOICE RECOGNITION hand control switch.
2. Say **ARTIST, ALBUM, GENRE, PLAYLIST** or **SONG** followed by the name or title to be played.
3. The radio may prompt for additional information. Respond to any remaining prompts to select and play the media.

## SAVING MEDIA FILE AS FAVORITE

See FAVORITES.

## SAVING MEDIA FILE AS RING TONE

Media from an iPod and files larger than 2 MB cannot be downloaded as a ring tone.

1. With media file playing, select **Menu**. If the current file type is compatible for use as a ring tone, a Ring Tone button is displayed.
2. Select **Ring Tone**. The radio will attempt to download the media file for use as a ring tone. The radio allows only one ring tone to be downloaded into the radio. Replace the existing file if necessary.
3. Select **OK**.





## ENABLING BLUETOOTH

Bluetooth must be enabled before pairing or connecting with Bluetooth devices.

1. Select **Home > Setup > Bluetooth Setup**.
2. See Figure 63. Check the **Bluetooth** checkbox to enable.



Figure 63. Bluetooth Setup Menu

## PAIRING A BLUETOOTH DEVICE

A maximum of six devices can be paired with the radio at one time. However, the radio only maintains an active Bluetooth connection with up to one device for phone service and one device for media at a time.

The motorcycle identifies itself as "H-D Radio". The name for the Bluetooth device is specified within the settings for your device.

### NOTE

*Phones may request permission to share information with "H-D Radio" (such as phone book contacts and text messages). These requests may occur during the pairing process or on other occasions when the phone is connecting with the radio.*

1. In the Bluetooth-compatible device, enable Bluetooth and set the device as discoverable. See the manual for your device.
2. In the radio, select **Home > Setup > Bluetooth Setup**.
3. See Figure 64. Select **List Paired Devices > Add a New Device**. All discoverable devices within range will appear in the list of found devices.
4. Select the device to be paired from the list.
5. The device will display a PIN code and prompt for permission to pair with "H-D Radio". Allow the pairing within the device.
6. See Figure 65. In the radio, select **Yes**. The radio will attempt to pair and connect with the device.
7. The system will prompt for an emergency phone number if one is not already stored in the system. Enter a phone number to call in the event of an emergency (such as 911).

8. Select **Save** in lower right corner of the screen.
9. The system begins downloading the phone book from the device. The Phone Book icon will be displayed in the status bar during the download process. During this process, the phone may prompt for permission to share the phone book.



**Figure 64. Adding a New Device**



**Figure 65. Pairing a Device: iPhone Example Shown**

## CONNECTING/DISCONNECTING A BLUETOOTH DEVICE

A Bluetooth device can be connected for phone service, media, or both. The system only allows one device to be connected for each Bluetooth service (phone or music).

The radio will automatically try to connect with the phone or media device after pairing. For some devices, a setting is required within the device before it will automatically connect. See the manual for the device.

To manually connect or disconnect with a Bluetooth device after pairing, use the following procedure. Also see MEDIA, Connecting Media Device (Bluetooth).

1. In the radio, select **Home > Setup > Bluetooth Setup**.
2. Select **List Paired Devices**. A device with a highlighted phone icon is connected for phone service. A device with a highlighted media icon is connected for media.
3. Select a device from the list to connect or disconnect.
4. See Figure 66. Select the appropriate button to connect or disconnect the device for phone service.
5. Select the appropriate button to connect or disconnect the device for music.



**Figure 66. Connecting or Disconnecting Phone or Music**

## RECONNECTING AFTER VEHICLE TURNS ON

When the motorcycle is turned on, the radio will automatically try to establish a Bluetooth connection with the phone from the last vehicle shutdown.

Allow a few moments for the radio to initialize and the phone connection to complete. The status bar displays the Bluetooth icon when the phone is connected.

The radio will not automatically reconnect with media devices over Bluetooth. Manually reconnect the phone and other media devices as necessary.

## DELETING A PAIRED DEVICE

A device will typically remain paired with the radio until deleted.

1. In the radio, select **Home > Setup > Bluetooth Setup**.
2. Select **List Paired Devices**.
3. Select the device from the list.
4. See Figure 67. Select **Delete Pairing**. Select **OK** to confirm.



Figure 67. Deleting a Paired Device

## PHONE COMPATIBILITY

Some phones may not be compatible with all the features and services in the radio. See the phone compatibility information at [www.h-d.com/boom](http://www.h-d.com/boom) (or the Boom! Box section of [www.h-d.com/touring](http://www.h-d.com/touring)). Some features may vary by region or carrier.

At a minimum, the phone must support the Bluetooth profiles shown in Table 18 to be compatible with various features in the radio. Even with these basic requirements, the phone may not necessarily be compatible with all features.

**Table 18. Required Bluetooth Profiles**

PROFILE	DESCRIPTION
A2DP/AVRCP Profile (AV/Music)	Connect media, media controls, metadata
Hands-Free Calling Profile (HFP)	Pairing, connecting, call features, battery indicator, signal strength indicator
HFP+PBAP+AV Profile	Calls and connection
Message Access Profile (MAP)	SMS text message features
Phonebook Access Profile (PBAP)	Phonebook download, call history download

## BLUETOOTH AND USB CONNECTIONS FOR PHONES

Phone services are only achieved through a Bluetooth connection. Connecting a phone to the USB port will allow the phone to charge and may provide additional media features. However, a USB connection alone will not operate the phone features.

The phone must be paired and connected through Bluetooth before operation. See BLUETOOTH.

## PHONE MENU

See Figure 68. Select **Home > Com > Phone** to access the phone features.



1. Phone book contacts
2. Dial phone number

3. Call history
4. Text messages

5. Emergency phone number
6. Bluetooth settings

**Figure 68. Phone Menu**

## CALL SCREEN

When a call is initiated or accepted, the Call screen is displayed as shown in Figure 69. This screen shows information for the current call.

While in an active phone call, you can change to other screens and use other features (such as navigation). However, other audio sources remain muted, paused or inaccessible until the phone call is finished.

Return to the Call screen to end the call or use other phone features. To return to the Call screen at any time during a call, press the HOME switch twice.

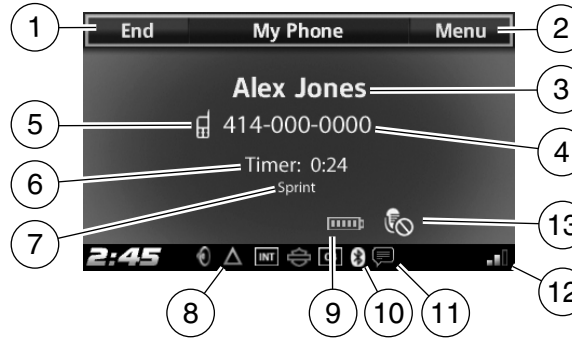

- 1. End call
- 2. Menu (microphone mute/unmute, keypad, call history, contacts, emergency call)
- 3. Contact name (if available)
- 4. Phone number
- 5. Contact type (home, mobile or work)

- 6. Elapsed time in call
- 7. Phone carrier
- 8. Roaming icon
- 9. Phone battery (5 bars)
- 10. Bluetooth connected

- 11. New message icon
- 12. Phone signal strength
- 13. Microphone muted

Figure 69. Call Screen

**Table 19. Call Screen Functions**

ITEM	DESCRIPTION
End	Press to end the current call.
Menu	Press to display other phone features (keypad for touch tones, mute/unmute, and so on).
Mute	Displays when microphones are muted.
Phone battery icon	Battery power for the phone (ranging 0 to 5).
Phone Book	Indicates when the phone book is being downloaded from the phone.
Phone signal strength icon	Signal strength (ranging 0 to 3).
New Message	Indicates a new text message has been received.
Roaming	Indicates that the phone is current in roaming mode.

3. See Figure 70. Type the full phone number using the keypad. Use the backspace/delete button or other characters as needed.
4. To add the phone number to the Saved list, select the **Save** button.
5. Select **Dial** in upper left corner.

## MAKING A CALL (DIALING)

1. Select **Home > Com > Phone**.
2. Select **Keypad**.



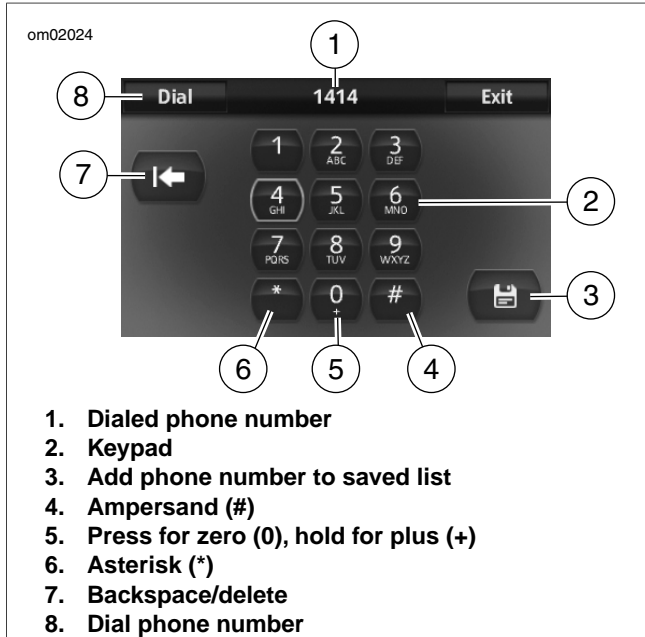

**Figure 70. Phone Keypad**

## MAKING A CALL (PHONE BOOK CONTACT)

1. Select **Home > Com > Phone**.
2. Select **Contacts > Phone Book**.
3. Select the contact name from the list. The letter jump feature can be used by pressing the center button in the scroll controls.
4. Select the desired phone number.

## MAKING A CALL (NAVIGATION POI)

Some points of interest in the navigation database include contact information.

1. Select **Home > Nav > POI**.
2. Select a POI destination.
3. Select the option menu button.
4. Select **Call**.

## MAKING A CALL (SIRIUSXM GAS STATION)

Some gas stations in the SiriusXM Fuel Prices feature include contact information.

1. Select **Home > SiriusXM > Specialty Services**.

2. Select **Fuel Prices**.
3. Select a gas station from the list.
4. Select **Call**.

## MAKING A CALL (EMERGENCY PHONE NUMBER)

An emergency phone number must be entered into the radio before using this feature. This is done when the phone is paired, or see PHONE, Changing the Emergency Phone Number.

1. Select **Home > Com > Phone**.
2. Select **SOS**.
3. Select **Dial**.

## MAKING A CALL (DIALING WITH VOICE RECOGNITION)

See VOICE RECOGNITION for more voice recognition instructions.

1. Press the VOICE RECOGNITION switch.
2. Say **DIAL** and speak the phone number into the microphone.

## MAKING A CALL (CALLING A CONTACT WITH VOICE RECOGNITION)

1. Press the VOICE RECOGNITION switch.
2. Say **CALL** and speak the contact name from the phone book or saved list.
3. If a contact has more than one phone number (home, mobile or work), the system will prompt for the correct phone number to use. Select the phone number to dial.

## RECEIVING A CALL (ACCEPTING/IGNORING)

When a call is received, the radio plays the ring tone and displays the incoming call information as shown in Figure 71. The call can either be accepted or ignored. Other audio sources are muted until the phone call ends.

**Accepting the call:** Select **Accept**. The call screen is displayed and the call begins.

**Declining the call:** Select **Ignore**. The phone declines the call and sends it to voicemail (or other function as determined by the phone manufacturer or carrier). The previous audio source resumes. See PHONE, Call History to display a list of missed calls.

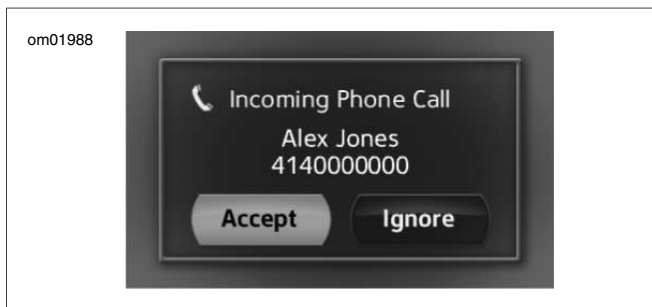

Figure 71. Incoming Call

## RECEIVING A CALL (RADIO TURNED OFF)

Phone calls can be received while the radio is turned off. When a call is received, the radio displays the call information and plays the ring tone. If the call is accepted, the phone features operate normally. The radio turns off when the call ends.

## ENDING A CALL

**Selecting the End button:** The call terminates. The caller can then be added to the saved list by selecting the Save button.

**Making a new call:** Initiating a new call will terminate the current call.

**Accepting a new call:** Accepting a new call will terminate the current call.

## ADJUSTING CALL VOLUME

During a call, use the volume hand control switch to adjust the incoming call audio. The passenger can use the volume controls on the Tour-Pak to adjust volume in the passenger headset.

## MUTING CALL AUDIO

**Muting microphones:** While in a call, select the **Menu** button. Select the **Mute/Unmute** button until **Mute** is displayed. The call screen displays a Mute icon in the lower right corner. Audio from the rider and passenger microphones will not be sent over the phone.

**Unmuting microphones:** Press the **Mute/Unmute** button until **Unmute** is displayed. The Mute icon is removed and the microphones resume normally.

**Muting inbound audio:** Use the volume hand control switch to adjust incoming audio to minimum volume. The POWER/MUTE button does not mute incoming phone audio.

## ROUTING CALL AUDIO

Outbound call audio is always spoken into the rider and passenger microphones. However, the inbound call audio can be

received through either the speakers or headsets. See SYSTEM SETTINGS, Speaker/Headset Selection.

## MULTIPLE CALLS

The radio only allows one active phone call at a time. When choosing to initiate or accept a new call, the other existing phone call is dropped.

**New incoming call (while call is in progress):** The system will prompt to either accept or ignore the new incoming call. If the new call is accepted, the existing call is dropped. If the new call is ignored, the current call continues.

**Starting a new call (while call is in progress):** Using the keypad, contacts list or emergency phone number, initiate the new call. When prompted, decide whether to continue with the existing call, or to start the new call (terminating the current call).

## VOICE MAIL

The radio does not indicate voicemail status. For most phone carriers, voice mail can be accessed by dialing the phone number for the mobile phone that you are using.

If a dial tone passcode is required to access voice mail, press the VOICE RECOGNITION switch during the call. Speak the passcode numbers and other special characters as needed.

For example, to enter a passcode as "1234#", speak **ONE-TWO-THREE-FOUR-POUND** into the microphone.

## PHONE BOOK

Contacts in a device's phone book can be used to initiate calls, display incoming caller information and navigate to a contact address. While multiple phone books can be stored in the radio from different paired phones, only the phone book from the currently connected phone is made available for use.

See Figure 72. The phone book displays entries for home, mobile, work or other phone numbers, according to the entries in the connected phone. If a contact does not have a phone number stored, the contact will not be displayed in the list.

When a paired phone is removed, the phone book is deleted. Pairing the phone again will require the phone book to be downloaded.



Figure 72. Phone Book

## SETTING UP CONTACTS IN A PHONE

Consider setting up contacts such as "Emergency", "Work", "Voicemail", "HOG" and "Dealer" in the phone. Use simple names so it will be easy to pronounce with the voice recognition commands. Include as much information as possible, such as alternate phone numbers and address information. With these items properly set up in the phone book, it becomes much easier to use voice recognition to say "Call Work" or to use phone book entries to route to a destination.

## REFRESH PHONE BOOK

The radio first downloads the phone book during initial pairing, and typically synchronizes with the connected phone when the vehicle is turned on. The phone book can be manually refreshed from the connected phone at any time.

1. Select **Home > Com > Phone**.
2. Select **Contacts > Refresh Phone Book**. The system begins downloading the current phone book from the device.
3. During the download process, the phone may prompt for permission to share the phone book. Allow the phone book to be downloaded.

## SHOWING CONTACT DETAILS

1. Select **Home > Com > Phone**.
2. Select **Contacts > Phone Book**.
3. Select a contact from the list.
4. Select **Show Details**. The name, phone numbers and address for the contact are displayed as shown in Figure 73. Selecting the address will begin navigation to that destination.

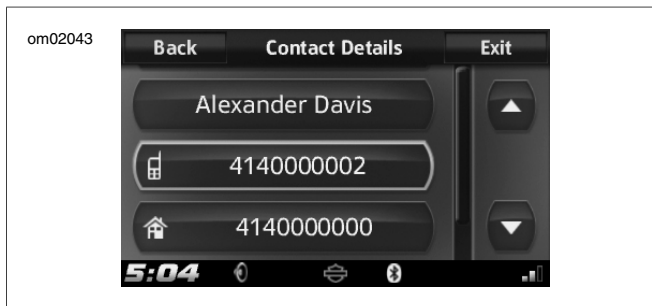

Figure 73. Contact Details

## VIEWING SAVED CONTACTS AND PHONE NUMBERS

The radio can locally store up to 200 contacts or phone numbers. After a phone number is saved, it can be used with any phone that is connected with the radio. Saved contacts which include addresses can also be used for navigation routing, even when the phone is not connected.

1. Select **Home > Com > Phone**.
2. Select **Contacts > Saved**.
3. Select a saved contact or phone number from the list.

4. Select the phone number to begin a call, or select the address to route navigation to the address.

## SAVING A PHONE BOOK CONTACT

1. Select **Home > Com > Phone**.
2. Select **Contacts > Phone Book**.
3. Select a contact from the list.
4. Select **Add to Saved Contacts**.

## SAVING A DIALED PHONE NUMBER

A phone number can be saved while dialing the number.

1. Select **Home > Com > Phone**.
2. Select **Keypad**.
3. Enter a phone number.
4. Select the **Save** button.

## SAVING PHONE NUMBER FROM CURRENT CALL

When a call is finished, the Save button is briefly displayed. Select the **Save** button to store the phone number to the saved list.

## DELETE SAVED CONTACT

1. Select **Home** > **Com** > **Phone**.
2. Select **Saved**.
3. Select a contact from the list.
4. Select the edit button (pencil).
5. Select the trash can button. Select **Yes** to confirm.

## CALL HISTORY

1. Select **Home** > **Com** > **Phone**.
2. Select **Calls**. A list of all call activity for the current phone is displayed as shown in Figure 74. The radio can display up to 60 total calls (20 missed, 20 received and 20 dialed calls).
3. To display only the missed, received or dialed calls, repeatedly select the button in the right corner.

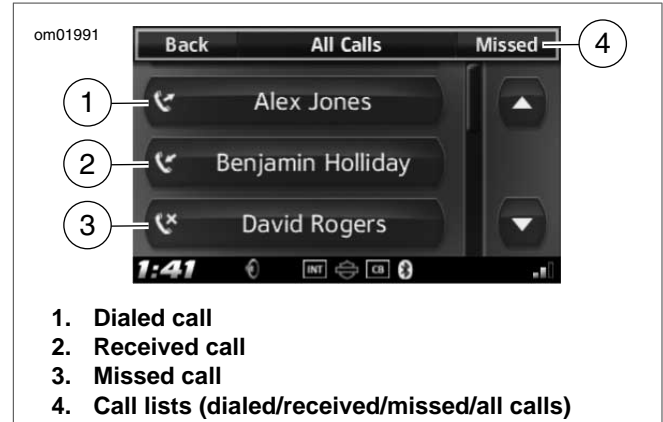

Figure 74. Call History

## TEXT MESSAGING

The radio can be used to read and listen to incoming text messages (using the text-to-speech feature). An auto-reply feature can also be configured. For safety purposes, the radio cannot be used to send text messages. Not all phones are compatible for text messaging features.

## ENABLING TEXT MESSAGE SERVICE (SMS)

1. Select **Home** > **Com** > **Phone** > **Message** to access text messaging features.
2. See Figure 75. Check the **Enable SMS** checkbox.

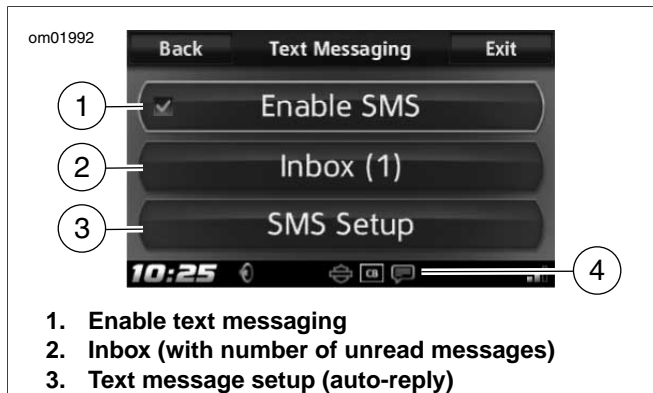

Figure 75. Text Message Menu

## ENABLING TEXT MESSAGE NOTIFICATION (APPLE DEVICES)

Notification settings need to be configured in Apple devices before the radio can receive text messages.

1. In the phone, select **Settings** > **Bluetooth**.
2. Select **H-D Radio**.
3. See Figure 76. Enable **Show Notifications**.
4. Select **Settings** > **Notifications** > **Messages**.
5. Select **Banners**.
6. Turn off the vehicle. Allow up to 30 seconds for the radio to completely shut down.
7. Turn on the vehicle. The system should now be able to receive text messages from the phone.

### NOTE

*If the alert style is set to Alerts, only the first text message received from another number will be shown on the radio.*



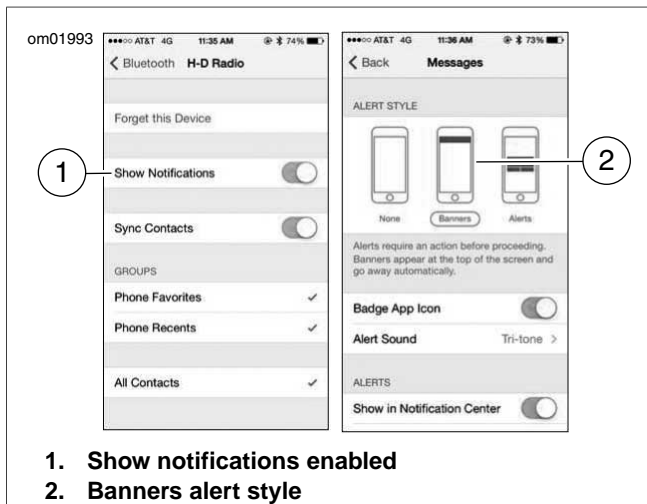
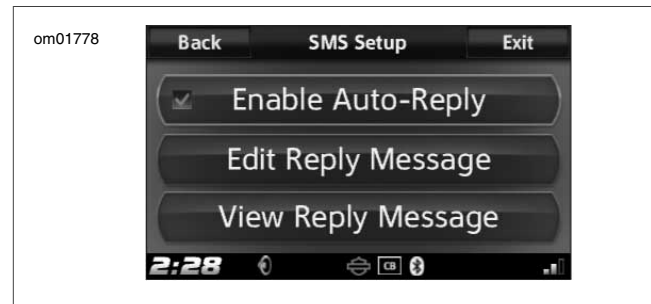

**Figure 76. Enabling Text Message Notification (Apple Device Settings)**

## TEXT MESSAGE AUTO-REPLY

1. Select **Home > Com > Phone > Message**.
2. Select **SMS Setup**.

3. Check the **Enable Auto-Reply** checkbox.
4. Select **View Reply Message** to view the current reply. Select **OK**.
5. See Figure 77. Select **Edit Reply Message**.
6. Enter new message. Select **OK**. The auto-reply feature will respond to incoming messages with a heading "Auto Generated Text" along with the contents of the personal message setting.



**Figure 77. Auto-Reply Message**

## VIEWING/PLAYING A TEXT MESSAGE

When a new message is received, the New Message icon is displayed in the status bar. This icon clears after the text message inbox has been viewed.

Text message viewing is locked out while the motorcycle is in motion. Instead, the text-to-speech feature will read the selected text message through the speakers or headsets.

### NOTE

*On the 4.3 radio, the text-to-speech feature is only available while the radio is set to American English.*

1. Select **Home > Com > Phone > Message**. The Inbox button shows the number of unread text messages.
2. Select **Inbox**. A list of messages displays the sender and the first portion of each text message.
3. See Figure 78. Select a message from the list. The full message is displayed. The text-to-speech feature reads the message over the speakers or headset.
4. To listen to the message again, select the **Repeat** button.
5. To display information about the text (sender, date and time stamp), select the information ("i") button.

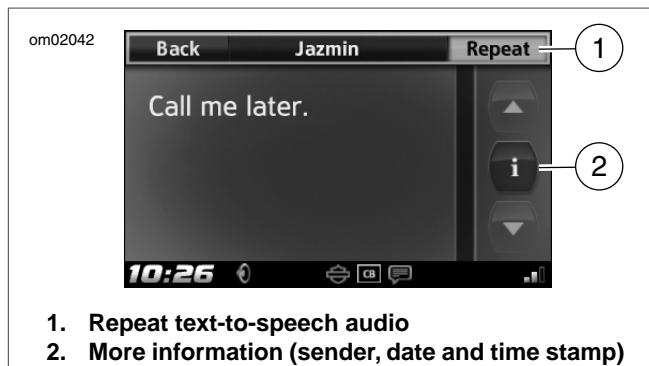

Figure 78. Viewing a Text Message

## SELECTING RING TONE

The radio has four built-in ring tones available (Rain, Suspense, Rave and Xylo). An additional ring tone can also be loaded into the radio.

1. Select **Home > Setup > Bluetooth Setup**. (Bluetooth Setup can also be selected in the phone menu.)
2. Select **Ring Tones > Select Ring Tone**.
3. See Figure 79. Select from the list of ring tones.

4. Select **OK**. A sample of the ring tone is played. The system will use the selected ring tone for all incoming calls.



**Figure 79. Selecting Ring Tone**

## ADDING NEW RING TONE (MEDIA FILE CURRENTLY PLAYING)

1. With media file playing, select **Menu** button in upper right corner of the media player.
2. Select **Ring Tones**. The radio stores the current file as a ring tone. The radio will prompt if the file is too large or when replacing an existing ring tone.

3. Select **OK**. The ring tone is stored in the radio and configured as the current ring tone.

## ADDING NEW RING TONE (BLUETOOTH SETUP)

1. Connect device (with ring tone file) to USB port.
2. Select **Home** > **Setup** > **Bluetooth Setup**. (Bluetooth Setup can also be selected in the phone menu.)
3. Select **Ring Tones** > **Load Ring Tones**.
4. Select device.
5. Find and select the file. The radio will prompt if the file is too large or when replacing an existing ring tone.
6. Select **OK**. The file is stored in the radio and configured as the current ring tone.

## RESUMING CALLS AFTER VEHICLE SHUTDOWN

If a call is active while the motorcycle is being turned off, the radio will request to transfer the call back to the phone as shown in Figure 80.

**Selecting Yes:** The call transfers back to the phone. The Bluetooth connection terminates and the radio shuts down.

**Selecting No (or not acknowledging the prompt):** The radio continues to support the call for approximately five minutes. At the end of this period, the radio attempts to transfer the call back to the phone and the radio shuts down.

*NOTE*

*Phone audio can only continue through the headset during this shutdown period. If the phone audio is routed through the speakers, the call will continue but the incoming audio will not be heard.*



**Figure 80. Transfer Call to Phone After Shutdown**

## TRANSFERRING A CALL BACK TO THE PHONE

Only use the phone handset manually while the motorcycle is stopped.

1. In the radio, select **Home > Setup > Bluetooth Setup**.
2. Select **List Paired Devices**.
3. Select the phone from the list.
4. Select **Disconnect Phone**. The Bluetooth phone connection terminates and the phone call transfers back to the phone handset.

## CHANGING THE EMERGENCY PHONE NUMBER

When the first phone is paired, the radio prompts for an emergency phone number. One emergency phone number can be stored in the radio. This same phone number is used for any phone connected to the radio.

1. Select **Home > Com > Phone**.
2. Select **SOS**.
3. See Figure 81. Select **Edit #** (to change the phone number) or **Clear** (to delete the current phone number).

4. Enter the new phone number to contact during an emergency (such as 911).
5. Select the **Save** button.



**Figure 81. Dialing or Editing Emergency Number**

*NOTES*

110 Phone



## CB RADIO

### WARNING

Set CB channel, squelch threshold and volume before riding to minimize adjustments on the road. Distractions can lead to loss of control, resulting in death or serious injury. (00089a)

### NOTICE

Operating the CB radio without an antenna or with a broken antenna cable can result in damage to the transmitter circuitry. (00176a)

### NOTICE

There are no adjustments internal to the CB transceiver chassis that can be performed without risking non-compliance with Federal Communications Commission (FCC) rules. Refer to the original equipment manufacturer for any service required during the warranty period. For transmitter service after the warranty period, refer to a certified repair service. Any frequency determining components, such as crystals, or power determining semiconductors, etc., should only be replaced with the original component manufacturer's part or equivalent. Substitutes can result in violation of FCC rules. (00175a)

Some models in select regions have a CB module. The CB radio can be used to communicate with other CB-equipped motorcycles (or other CB users) on any of the 40 Citizen Band channels.

Regulations for CB operation, specific frequencies or power output may be unique for different regions. Check local laws and regulations before operating the CB radio. In the United States, read *Part 95, FCC Rules and Regulations* (included in this manual) before operating your transmitter.

## TURNING CB ON

The CB must be turned on before using. After the CB is turned on and a channel has been selected, you can leave the CB screen and use other radio features (such as listening to tuner stations, making phone calls, using navigation features, or listening to media files). The CB remains muted but continues operating in the background. The rider and passenger can transmit or receive CB audio at any time while on any screen.

1. Select **Home > Com > CB**.
2. See Figure 82. Press the button in the upper left corner of the CB screen until it displays **On**. The middle of the screen shows the current channel and CB On. The CB icon is displayed in the status bar while the CB remains on.

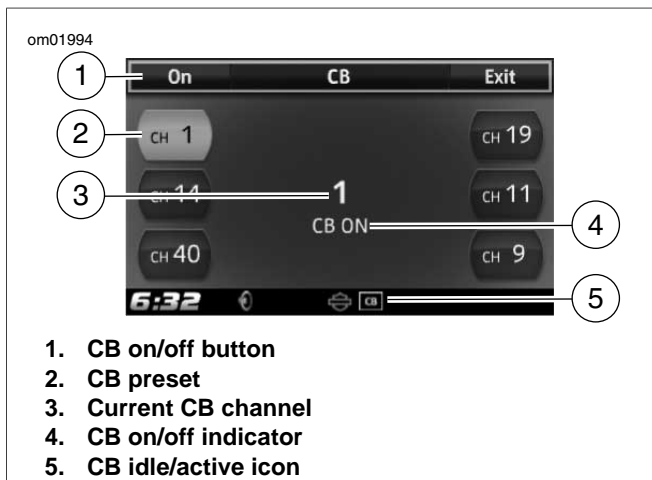

Figure 82. CB Screen

## TURNING CB OFF

On the CB screen, press the button in the upper left corner until it displays **Off**. The CB presets will be disabled, the middle of the screen will show CB Off, and the CB icon in the status bar will turn off.

## CONFLICTING TRANSMISSIONS

CB channels are mutually shared among many users. Interruptions and conflicting transmissions from multiple users on a channel can make it difficult for your intended recipient to understand your message. To make sure that your transmission is received well, and as a courtesy to others, wait until the channel is clear before pressing the PTT switch.

If too many users are actively using a channel, try to specify another possible channel to your intended recipients so you can resume your conversation together on that channel.

For important communications, make sure that your recipient acknowledges that they have received and understand your message.

## EMERGENCY OPERATION (CHANNEL 9)

In the US, the FCC has reserved channel 9 for emergency or traveler assistance use only. Use of this channel should only be for issues involving personal safety, damage to property or other required assistance. Channel 9 is also reserved for emergency use in most other countries that allow Citizen Band radio.

When using this channel for emergencies or assistance, clearly identify the nature of the problem and your location. If no



response is received, try other channels or find another way to get help.

## TRANSMITTING ON CB

**Start transmitting:** While on any screen, wait until other active CB transmissions are finished and the channel is clear. Press and hold the PTT switch to begin transmitting on the current CB channel. Any sound picked up from the rider and passenger microphones will be transmitted. While the PTT switch is held, all other audio is muted, including any inbound CB messages that may be coming in. The CB Active icon will be displayed in the status bar during the transmission.

**Stop transmitting:** Release the PTT switch to stop transmitting. The status bar will show the CB Idle icon. Audio will be resumed, and any CB audio that breaks squelch will be received.



Figure 83. CB Active

## RECEIVING CB AUDIO

The radio will receive inbound CB audio while on any screen. When an incoming CB signal breaks squelch, the CB audio interrupts (or mixes) with the current audio source in the radio. While CB audio is being received, the CB Active icon is displayed in the status bar.

If necessary, adjust the squelch level so noise does not break squelch, but desired CB audio is still received.

CB audio is received through the speakers or the headsets, depending on the audio routing settings. See SYSTEM SET-

TINGS, Speaker/Headset Selection. Both rider and passenger headsets will receive inbound CB audio.

## TUNING CB CHANNELS

The CB radio can access all 40 channels. While on the CB screen, press the PREVIOUS/NEXT hand control to advance through the CB channels individually. Channels can only be changed while in the CB screen.

Table 20 shows some of the popular CB channels used. Refer to local regulations for any further restrictions or recommendations on local channel use.

**Table 20. CB Channels (Popular or Reserved)**

CHANNEL	DESCRIPTION
Channel 8	Unofficial travelers channel (Australia)
Channel 9	Reserved for emergency and traveler assistance use only (most countries)
Channel 13	Unofficial travelers channel (Greece)
Channel 15	Unofficial travelers channel (Russia)
Channel 17	North-south freeway trucker channel (US)
Channel 19	East-west freeway trucker channel (US) Unofficial travelers channel (most countries)

## CB PRESETS

The CB screen stores six preset channels. Save your most commonly used channels as presets so they can be easily accessed. Some recommended presets include channel 9 (emergency channel) and channel 19 (unofficial travelers channel).

**Setting CB preset:** Tune to a CB channel. Press and hold a CB preset button until the system beeps and the channel is saved.

**Recalling CB preset:** With the CB turned on, press the desired CB preset button.

### NOTE

*CB channels cannot be configured as global presets or favorites.*

## SQUELCH

The squelch level determines the minimum signal strength that will unmute CB reception. When a CB signal exceeds the selected threshold, the radio will "break squelch". The current audio source (such as a radio station or media file) mutes and the CB channel is unmuted.

**Adjusting squelch:** See Figure 84. With the CB turned on, push down the squelch switch (SQ-) until noise and static are

heard. The CB Active icon will be displayed. Then push up the squelch switch (SQ+) one or two levels. This eliminates noise while allowing any stronger signals to break squelch.

**Intermittent noise:** If intermittent noise or undesired weak CB signals continue to break squelch, consider raising the squelch further. However, setting the squelch too high can prevent desired CB audio from being received.

**Maximum squelch:** At maximum squelch, the radio will not break squelch for any signal. All inbound CB signals are effectively muted.

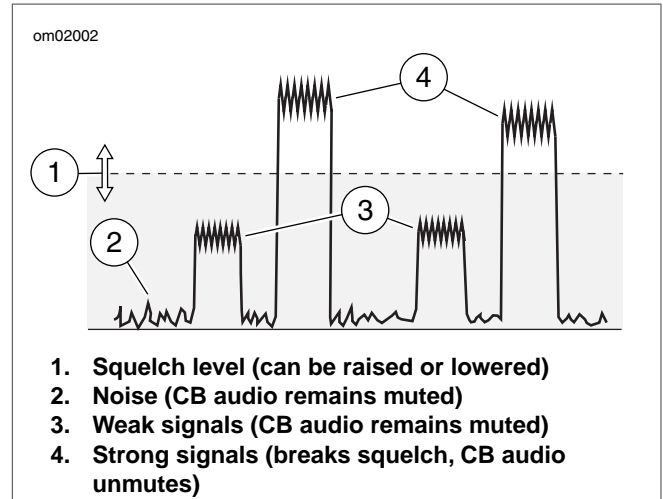

Figure 84. Squelch (Conceptual Illustration)



Figure 85. CB Squelch Level

## CB VOLUME

**CB audio routing:** CB audio can be routed to the speakers or the rider/passenger headsets. See SYSTEM SETTINGS, Speaker/Headset Selection.

**Adjusting CB volume (while on CB screen):** Use rider volume controls to adjust speaker or rider headset volume. Use passenger volume controls to adjust passenger headset volume.

**Adjusting CB volume (while not on CB screen):** See Figure 86. While CB audio is being received, use the rider or passenger volume controls. If necessary, first reduce the

squelch until CB audio breaks squelch, then adjust the volume. Raise the squelch to its original level.

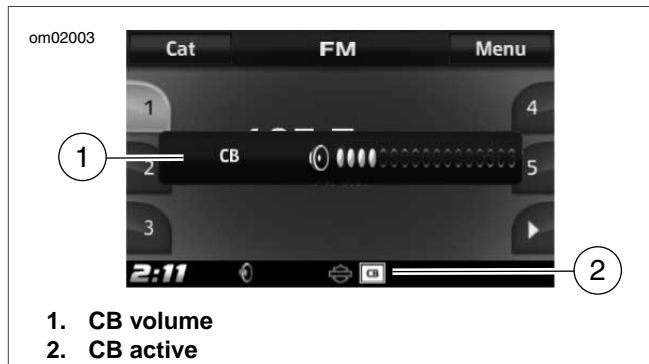

Figure 86. CB Volume

## PASSENGER CB OPERATION

The passenger can also transmit over the current CB channel, adjust CB volume for the passenger headset and listen to inbound CB audio in the passenger headsets. The passenger cannot adjust speaker volume, adjust squelch or change CB channels.

**Initiating CB transmission (passenger):** When channel is clear, press and hold the passenger PTT switch on side of Tour-Pak. Both the rider and passenger microphones become active. Release PTT switch when finished.

**Adjusting CB volume (passenger):** While on CB screen (or while CB is in operation), use UP/DN switch on side of Tour-Pak to adjust passenger headset volume. The volume switch does not affect the speakers or rider headset volume.

## **FACTORS AFFECTING CB RANGE**

Adverse weather, buildings, hills and valleys can affect the maximum range for the CB radio. Degraded reception or transmission capability can also occur in tunnels or parking garages. The CB transmitter is the most powerful allowed under US federal law. However, since there is no large steel area to

create a ground plane, the CB may not transmit as strongly as CBs mounted in a car or truck.

## **ADDING AN OPTIONAL CB MODULE**

Bike-to-bike (CB) communication is standard on some vehicles in select locations. For vehicles not equipped with a CB, the optional CB accessories can be purchased at [www.h-d.com/store](http://www.h-d.com/store) or at an authorized Harley-Davidson dealer.

Installation of the CB module may only be allowed in particular regions. See [www.h-d.com/store](http://www.h-d.com/store) or your authorized Harley-Davidson dealer for fitment and requirements. Follow the instruction sheet procedures or have an authorized Harley-Davidson dealer install the accessory. For set up and operation, use the instructions in this manual.

*NOTES*

118 Citizen Band (CB) Radio



## INTERCOM

The intercom allows the rider and passenger to talk with each other through the headsets. The intercom can be operated by pressing the PTT switch or by using voice operated transmission (VOX). When voice input is picked up by the rider or passenger microphone, the intercom is automatically activated. This process is known as "breaking VOX".

The rider or passenger can initiate intercom communication. When the intercom is active, tuner and media volume are automatically reduced so the intercom can be heard through the headsets.

For privacy, the intercom is only heard through the rider and passenger headsets. It is not heard through the speakers.

Microphone sensitivity and headset volume can be adjusted. The microphone sensitivity (VOX) applies to both rider and passenger microphones. The rider and passenger headset volumes are adjusted independently.

### NOTE

*Some local governments prohibit or restrict the use of headset (helmet-mounted) speakers. Check with local authorities and obey all applicable laws and regulations.*



1. Intercom on/off button
2. Voice activation (VOX) sensitivity level
3. Minimum level (PTT activation only)
4. Maximum level (open microphone, intercom on continuously)
5. Intercom state (on/off)
6. Intercom active/idle

Figure 87. Intercom Screen

## TURNING INTERCOM ON/OFF

1. Select **Home** > **Com** > **Intercom**.
2. Select the button in upper left corner until it displays **On** or **Off**. When turned on, the intercom is available for use

and the intercom icon is displayed in the status bar. The intercom can be used while on any screen.



## ADJUSTING MICROPHONE SENSITIVITY (VOX)

VOX sensitivity should be adjusted so the microphones break VOX at normal voice volume. The sensitivity level applies to both the rider and passenger microphones.

Adjust the sensitivity as needed if the microphone breaks VOX from unintended sounds, such as road or background noise.

1. Select **Home > Com > Intercom**.
2. While speaking into the microphone, use the controls (+ and -) to adjust the sensitivity until your normal voice volume breaks VOX. The intercom icon in the status bar should be white (active) when speaking at a normal tone.

**Raise sensitivity:** Move the level to the right. The microphone becomes more sensitive. The intercom will activate (break VOX) with quieter sounds through the microphone.

**Reduce sensitivity:** Move the level to the left. The intercom will only activate (break VOX) with louder voice or sounds.

**Fully open microphone:** Raising the sensitivity to the maximum level will keep the intercom microphone open continually.

**PTT only:** Reducing the sensitivity to the minimum level will prevent any VOX operation. The intercom can only be activated with the PTT switch.

## SPEED VOLUME

Speed volume is applied to the intercom to compensate for engine noise, wind and road input. As the motorcycle speed increases, the sensitivity of the microphones will automatically decrease. This prevents road noise from breaking VOX. It also prevents unnecessary adjustments to the microphone sensitivity while riding.

## ADJUSTING INTERCOM VOLUME (RIDER AND PASSENGER HEADSETS)

1. Activate the intercom (press the PTT switch or speak loud enough to break VOX).
2. Adjust the volume while the intercom is active. The intercom volume displays on the screen while the intercom is activated. Rider and passenger headset volumes are independently controlled.

**Rider:** Press the volume controls on the left handlebar.

**Passenger:** Press the VOL+/VOL- switch on the side of the Tour-Pak.

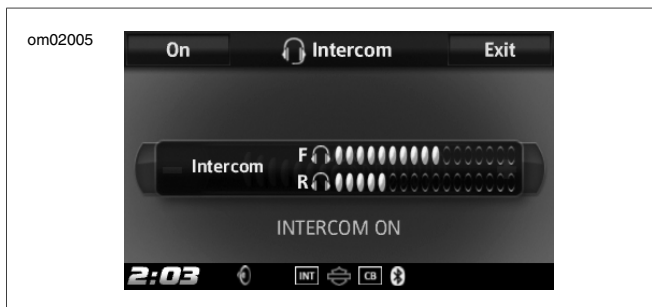

Figure 88. Intercom Volume

## OPERATING INTERCOM (VOICE ACTIVATION, VOX)

Speak into the microphone at an adequate level to break VOX. The tuner or media volume will reduce into the background so the intercom can be heard. The intercom icon will turn white (active).

The intercom audio will be heard in the headsets. VOX activated communication is not broadcasted over the CB.

## OPERATING INTERCOM (PTT SWITCH)

1. Press and hold the PTT switch (rider or passenger) to activate the intercom. The intercom icon will turn white (active). The tuner or media volume will mute so the intercom can be heard.
2. Speak into the microphone. While the PTT switch is held, the microphones will remain active regardless of the VOX setting or sound level.

### NOTES

- *If the CB is turned on, pressing the PTT switch will also activate the CB. Any sound in the microphones will be shared over the current CB channel. Turn off the CB or use the voice activation (VOX) feature if there is a need to communicate privately.*
- *To activate the intercom with only the PTT switch (rather than VOX), reduce the VOX sensitivity to its lowest level. See INTERCOM, Adjusting Microphone Sensitivity (VOX).*

## SIRIUSXM SATELLITE RADIO

SiriusXM radio is equipped on select vehicles in North America. See FEATURES AND SPECIFICATIONS. The radio includes over 200 digital channels of music, news, talk, entertainment and sports. The radio broadcast is over satellite (with ground repeaters) to provide consistent programming and signal quality nationwide without a break in coverage.

SiriusXM specialty services provide weather mapping, weather forecast data, fuel price information and traffic data service. SiriusXM traffic provides information for traffic events and road conditions. This data is integrated with the navigation system to provide speed flow along selected routes and notifications of traffic situations (such as accidents or lane closures).

## OPTIONAL SIRIUSXM ACCESSORY

SiriusXM functionality is standard on select vehicles in covered regions. For vehicles not equipped with SiriusXM, the optional SiriusXM accessory can be purchased at [www.h-d.com/store](http://www.h-d.com/store) or at an authorized Harley-Davidson dealer. See dealer or website for fitment and requirements when adding this accessory.

Follow the instruction sheet procedures or have an authorized Harley-Davidson dealer install the accessory. After installation, use the instructions in this manual to set up, subscribe and operate the SiriusXM features.

## TRIAL SUBSCRIPTION

New vehicles equipped with SiriusXM from the factory include a three-month trial subscription for SiriusXM Radio, Traffic and Travel Link service in regions where service is available. This trial subscription is only available to the original purchaser of a new SiriusXM equipped vehicle, and is not included with SiriusXM modules that may be subsequently purchased or installed by the customer or dealer. Terms and conditions of service may be modified from time to time by SiriusXM. See [www.siriusxm.com](http://www.siriusxm.com).

## CHECK SUBSCRIPTION STATUS

1. Select **Home > Setup > SiriusXM Setup**.
2. Select **Subscription**.
3. **Radio subscription:** See Figure 89. Select **Radio**. The Radio Services subscription status is displayed with an ESN number and SiriusXM phone number for assistance or activation.  
**Specialty services:** See Figure 90. Select **Specialty Services**. The subscription status for each service (traffic, fuel, weather and forecast services) is displayed with an ESN number and SiriusXM phone number for assistance or activation.



**Figure 89. Radio Service Subscription Screen**



**Figure 90. Specialty Services Subscription Information**

## SUBSCRIBING TO SIRIUSXM

1. See Figure 91. Turn on the radio. SiriusXM starts up with a preview channel (channel 1) until subscription is active.
2. Get the ESN number for the radio. See SIRIUSXM, Check Subscription Status.
3. Verify that the SiriusXM signal is being received. Check the SiriusXM Signal Strength icon in the status bar. Channel 1 (preview channel) should be playing audio.
4. **Subscribe by internet:** Go to [www.siriusxm.com](http://www.siriusxm.com). Click the subscription link.  
**Subscribe by phone:** Call the phone number on the ESN screen. See SIRIUSXM, Check Subscription Status.
5. Keep the radio turned on until the subscription process is complete. Activation may take up to an hour. Since the vehicle will automatically turn off after 20 minutes in accessory mode, it may be necessary to start up and ride the motorcycle.



Figure 91. SiriusXM Preview Channel

## LISTENING TO SIRIUSXM RADIO

SiriusXM features may take a few moments to be displayed after the motorcycle is first started.

1. Select **Home** > **SiriusXM**.
2. See Figure 92. Select **Radio**.



Information Provided by:

**DEALER**  
E-PROCESS



- |  |                   |                             |
|--|-------------------|-----------------------------|
| 1. Channel (category selection)                              | 4. Song title     | 7. Channel Name             |
| 2. Presets   | 5. Artist         | 8. Category                 |
| 3. Menu (seek/preset, scan, direct tune, tagging, game zone) | 6. Channel number | 9. SiriusXM signal strength |

Figure 92. SiriusXM Radio Screen

## SIRIUSXM PRESETS

Channel presets can be programmed to quickly access favorite channels. The radio includes 20 SiriusXM presets.

1. Select a channel.
2. Press and hold a preset until the system beeps.

## SELECTING A CHANNEL (HAND CONTROLS)

**Advancing through channels:** Press the PREVIOUS/NEXT hand control switch to change the channel.

**Changing seek/preset mode:** From the SiriusXM screen, select **Menu**. Press the multiselect button to choose **Seek** (PREVIOUS/NEXT switch will advance to next channel) or **Preset** (PREVIOUS/NEXT switch will advance to next preset).

## SELECTING A CHANNEL (CHANNEL LIST)

1. See Figure 93. From the SiriusXM screen, select **Channel**. A list of channels are displayed. If specific categories have been selected, the list will only display channels that apply to those categories. See SIRIUSXM, SiriusXM Categories.
2. Use the scroll controls to advance through the list.
3. Select the middle button to toggle the list between channel name, artist, current song.
4. Select a channel from the list.

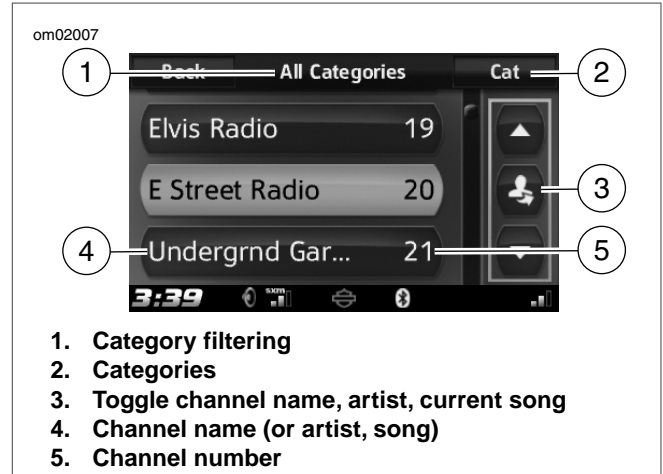

Figure 93. Channel List

## SELECTING A CHANNEL (DIRECT TUNE)

1. See Figure 94. From the SiriusXM screen, select **Menu**.
2. Select **Direct Tune**.
3. Use the keypad to enter a channel number.

4. Select **Tune** to change to the selected channel.

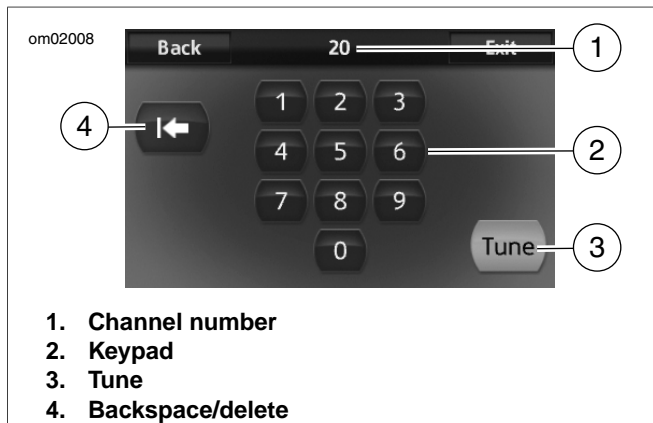

Figure 94. Direct Tune

## SELECTING A CHANNEL (VOICE RECOGNITION)

See VOICE RECOGNITION for additional commands and instructions.

1. Press the VOICE RECOGNITION switch.

2. Speak one of the following commands into the microphone:

**Listen to SiriusXM radio: X M**

**Select a channel: CHANNEL** (followed by the channel name or number)

**Select next channel up: CHANNEL UP**

**Select next channel down: CHANNEL DOWN**

**Scan channels: CHANNEL SCAN**

## SCANNING SIRIUSXM CHANNELS

1. From the SiriusXM screen, select **Menu**.
2. Select **Scan**. The radio will advance through each channel, dwelling for five seconds on each channel.
3. Press the CURSOR/SELECT hand control switch to select a channel.

## TAGGING AN ARTIST OR SONG

Tagging allows you to be alerted when a tagged artist or song is playing on any SiriusXM channel. Up to 20 song or artist tags can be saved.

1. From the SiriusXM screen, select **Menu**.
2. While the song or artist is playing, select **Tag This**.



3. The system prompts to tag the song or the artist. Once tagged, the system will confirm your selection.

## VIEWING TAGGED LIST

1. From the SiriusXM screen, select **Menu**.
2. Select **Tagged**.
3. See Figure 95. To turn off alerts for a particular song or artist, uncheck the item in the list. To resume alerts, check the item again.

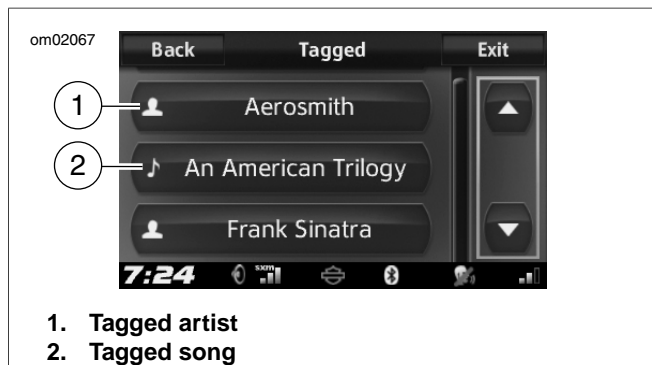

Figure 95. Tagged List

## TAG ALERT

An alert pops up when a tagged song or artist plays on any channel. Select **Listen** or **Ignore**.

**Listen:** Changes to the channel with the tagged song or artist playing.

**Ignore:** Remains on the current channel.

## SIRIUSXM CATEGORIES

The radio can be configured to seek or scan for particular types of programming (such as news, sports or classical music). When seeking or scanning, the radio only stops on stations with the selected categories. The channel list will include only stations with the selected categories.

1. From the SiriusXM screen, select **Channel**.
2. Select **Cat**.
3. See Figure 96. Select the desired categories from the list.



**Figure 96. SiriusXM Categories**

## GAME ZONE

Game Zone can be set up to trigger an alert when games are broadcasting or score changes occur for your favorite teams. The alerts provide an opportunity to tune to the channel and listen to the game.

## ENABLING SPORTS ALERTS

Sports Alerts must be enabled before the radio provides game or score notifications.

If Sports Alerts is disabled, all the game and score settings configured for your favorite teams are still retained. However,

the system will not provide notifications until Sports Alerts is enabled again.

1. From the SiriusXM screen, select **Menu > Game Zone**.
2. Check the **Sports Alerts** checkbox. Game and score alerts that have been set for any favorite teams will be displayed as they occur.

## ADDING A GAME ZONE FAVORITE

Up to seven teams can be added as Game Zone favorites.

1. From the SiriusXM screen, select **Menu > Game Zone**.
2. Select the type of team (MLB, NBA, and so on). A list of teams within the selected league are shown.
3. Select a team from the list.
4. To display an alert whenever a game is being broadcast for this team, check the **Game** checkbox.
5. To display an alert whenever a score changes in a game for this team, check the **Score** checkbox.
6. Select **Add to Favorites**. If either of the checkboxes are selected, the team automatically becomes a favorite.

## SETTING GAME OR SCORE NOTIFICATION

1. From the SiriusXM screen, select **Menu > Game Zone**.
2. Check the **Sports Alert** checkbox (if unchecked).
3. Select **Favorite Teams**.
4. See Figure 97. Select a team from the list.
5. **Game notification:** To display an alert whenever a game is being broadcast for this team, check the **Game** checkbox.
6. **Score notification:** To display an alert whenever a score changes in a game for this team, check the **Score** checkbox.

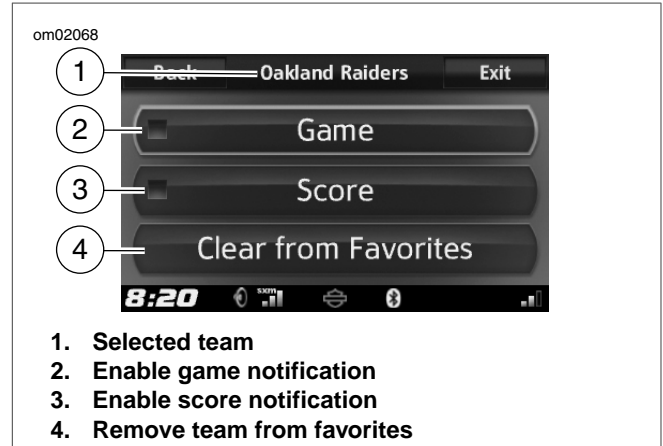

Figure 97. Setting Game or Score Notification

## RESPONDING TO GAME ZONE ALERT

See Figure 98. Depending on the settings, a Game Zone alert pops up when a game is being broadcasted or a score change has taken place for a favorite team.

**Listen:** The radio tunes to the channel that is broadcasting the game.

**Ignore:** The radio continues with its current audio source.

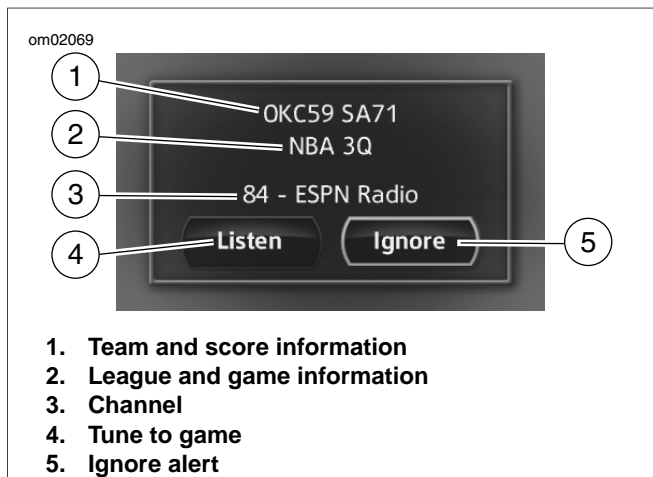

Figure 98. Game Zone Alert

3. Select the team to be removed from the list.
4. Select **Clear from Favorites**. The team will be removed from the Game Zone favorites list.

## DISPLAYING CURRENT WEATHER

1. From the SiriusXM screen, select **Specialty Services > Forecast**.
2. Select **Current Location** or **Other Location**.
3. If selected Other Location, select the state and location to view.
4. See Figure 99. Select **Current**. The screen shows the current weather conditions.
5. See Figure 100. Select **Details** to display a detailed list of weather conditions.

## REMOVING A GAME ZONE FAVORITE

1. From the SiriusXM screen, select **Menu > Game Zone**.
2. Select **Favorite Teams**.



Figure 99. Current Weather

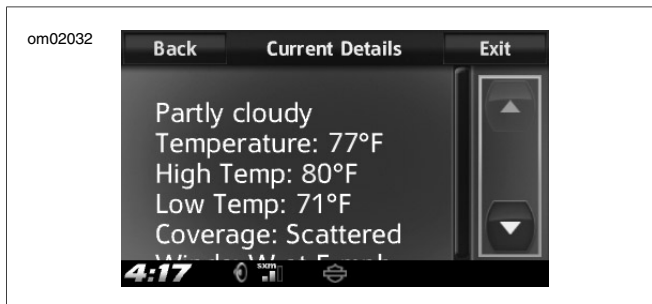

Figure 100. Current Weather Details

## DISPLAYING DAILY FORECAST (3 AND 6 HOUR)

1. From the SiriusXM screen, select **Specialty Services > Forecast**.
2. Select **Current Location** or **Other Location**.
3. If selected **Other Location**, select the state and location to view.
4. See Figure 101. Select **Daily**. The screen shows the forecasted weather conditions in 3 hours and 6 hours.



Figure 101. Daily Weather Forecast

## DISPLAYING 5 DAY FORECAST

1. From the SiriusXM screen, select **Specialty Services > Forecast**.
2. Select **Current Location** or **Other Location**.
3. If selected **Other Location**, select the state and location to view.
4. See Figure 102. Select **5 Day**. The screen shows the forecasted weather conditions for today and tomorrow.
5. Use the scroll controls to scroll through the next five days of weather data.

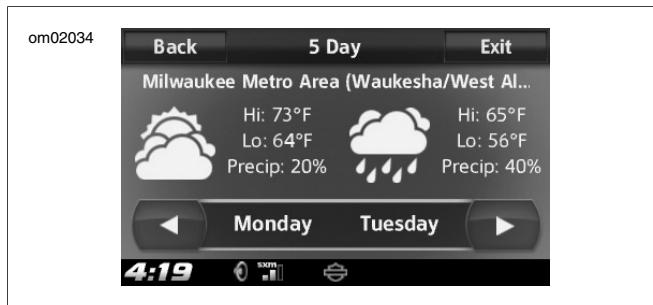

Figure 102. 5 Day Weather Forecast

## SIRIUSXM FUEL PRICES

The fuel feature provides the fuel prices at stations within a specified distance of the motorcycle. This feature can be used to route to a selected station, or add stations to an existing route.

## SELECTING FUEL TYPE

The radio shows locations and prices according to the fuel type that is selected (regular, medium, super or diesel).

### NOTE

*Use only unleaded gasoline with the fuel type and octane specified for your motorcycle. Do not use diesel or other inappropriate fuels for the motorcycle. See the vehicle owner's manual. Using the wrong type of fuel can damage the engine, fuel system and other components.*

1. From the SiriusXM screen, select **Specialty Services > Fuel**. The radio displays the fuel type that is currently selected.
2. Select **Fuel Type**.
3. Select the fuel type from the list. This fuel type will be used when searching for prices.

## VIEWING FUEL PRICES

### NOTE

Fuel prices are shown per gallon or liter, depending on the English/Metric setting.

1. From the SiriusXM screen, select **Specialty Services > Fuel**.
2. Check that the fuel type is appropriate.
3. See Figure 103. Select **View Prices**. A list of up to 30 nearest stations within 100 miles are displayed. The stations are listed by distance from the current location.
4. **Sort by brand/price/distance:** Select the middle scroll button to sort the list by brand (station name), fuel price, or distance to the station.
5. Select a station from the list.

**Route to station:** Select **Route/View**. To add the station to an existing route, select **Add**. Otherwise, select **OK**.

**Call station:** With phone connected, select **Call**. The phone dials the gas station (to confirm prices, check operating hours, and so on).

**See all prices at station:** Select **Fuel Prices** to display the prices for all fuel types at the station. A date stamp for the price data is also displayed.

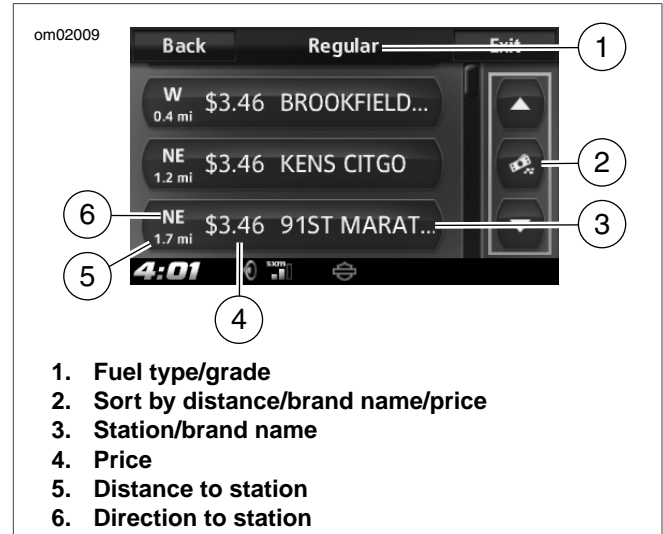

Figure 103. Fuel Prices

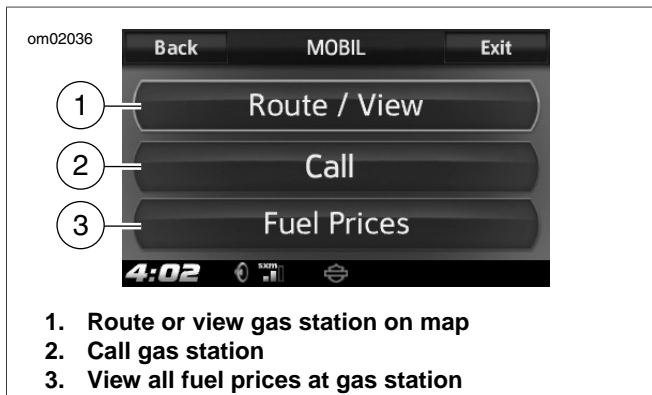

Figure 104. Gas Station Selected

## SIRIUSXM TRAFFIC

SiriusXM Traffic displays a list of messages regarding traffic, construction, accidents or other events nearby that may impact your chosen route. The system can be configured to provide popups of traffic events, and provide new routes to avoid traffic obstructions.

## TURNING TRAFFIC ON

When using the traffic feature, the system will automatically prompt to turn on traffic if necessary. Traffic can also be enabled in the system settings. See NAVIGATION, Turning Traffic On/Off.

## TRAFFIC NOTIFICATION POPUPS

The system can be configured to automatically display traffic alerts that affect the current navigation route. The system will only display the notification when a route is currently active and an alternative route would reduce the current ride time by five minutes or more.

See NAVIGATION, Rerouting.

## TRAFFIC ICONS

A description of all traffic icons is displayed in the Setup menu. Select **Setup > Traffic > Legend**.

Also see NAVIGATION, Traffic Event List (RDS Traffic).

## TRAFFIC REROUTE

See NAVIGATION, Rerouting.



## TRAFFIC MESSAGE LIST

1. From the SiriusXM screen, select **Specialty Services > Traffic**.
2. If prompted to turn on traffic, select **Yes**.
3. See Figure 105. A list of nearby traffic events is displayed. Each item displays the direction and distance to the traffic event. Road signs and traffic icons are also displayed.
4. To toggle between all nearby events or only events along the route, select the circular arrow button on the right side of the screen.
5. See Figure 106. Select an item from the list to display a detailed traffic message. The radio reads the text message over the speakers or headset by using the text-to-speech feature. While riding, the scroll feature for the message is locked out.
6. See Figure 107. Select the Map icon to display the incident location on the map.

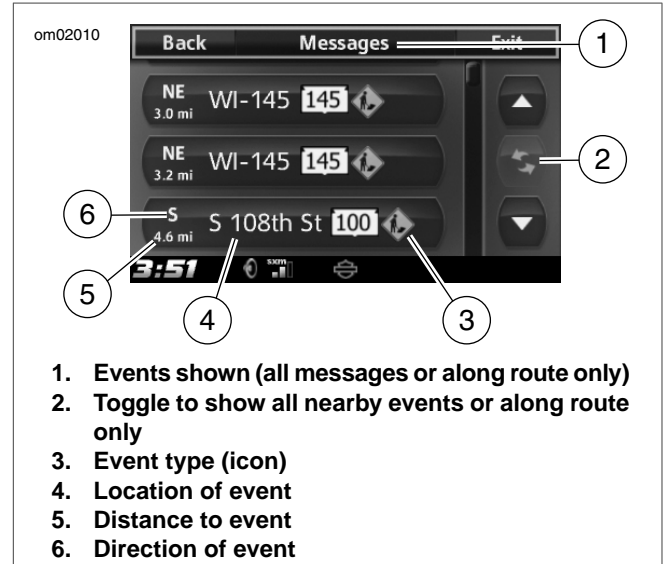

Figure 105. Traffic Message List

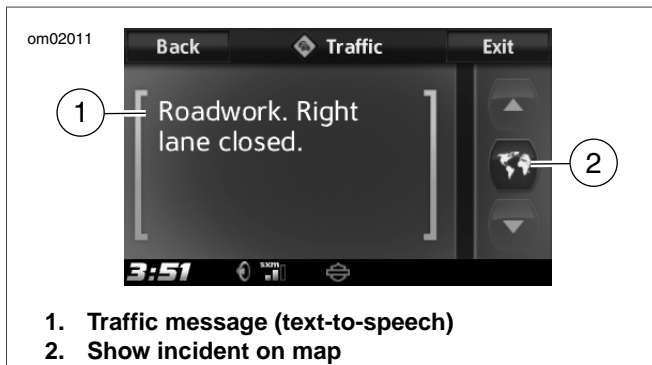

Figure 106. Traffic Message

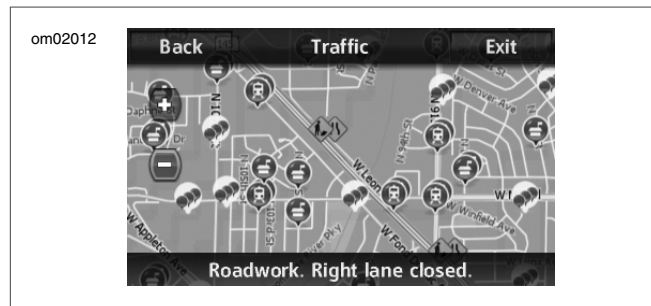

Figure 107. Traffic Incident Displayed on Map

## SIRIUSXM WEATHER MAP

SiriusXM weather displays a map with radar and weather front information. The map is displayed in north up orientation and is typically updated every 12 minutes. The weather map displays major roadways, but it is not designed as a tool for navigation.

1. See Figure 108. From the SiriusXM screen, select **Specialty Services > Weather**. The radio displays a large scale map with the current location of the vehicle.
2. Select the map options button to configure the display of the map.

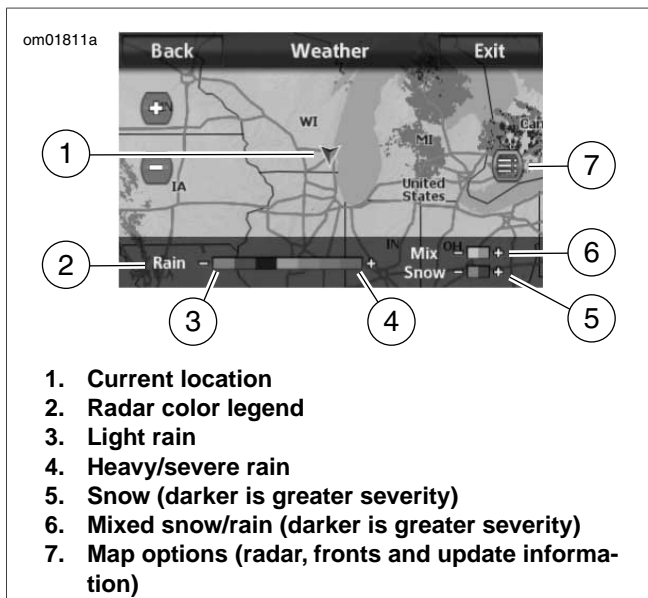

Figure 108. Weather Map

## WEATHER MAP SCROLLING

1. With the weather map displayed, press a location on the touchscreen, or press and hold the CURSOR/SELECT hand control switch.
2. Use the cursor arrows to scroll across the map. Use the zoom controls to zoom in or out.

## WEATHER MAP RADAR AND FRONTS

The radar displays patterns of precipitation on the map. The intensity of rain, snow or mixed precipitation is indicated by the legend on the bottom of the map. The map can also display weather fronts, atmospheric pressure and isobars.

1. While in the weather map, select the option button on the right side of the screen.
2. **Turn on radar:** Check the **Radar** checkbox.
3. **Turn on weather fronts:** Check the **Fronts** checkbox.
4. Select the **Back** button. Radar formations and weather fronts are displayed on the map.

**Table 21. Radar Information**

PRECIPITATION TYPE	INTENSITY
Rain	Seven color levels ranging from light rainfall (light green) to severe (red)
Snow	Light snowfall (light blue), heavy snowfall (dark blue)
Mixed	Light mixed precipitation (light pink), heavy mixed (dark pink)

**Table 22. Weather Front Information**

INDICATOR	DESCRIPTION
Cold front	Shown as a blue line with triangles. Displays the leading edge of a cold air mass. The triangles show the forward direction of the front.
High pressure (H)	Shows center of high atmospheric pressure.
Isobar	Thin line which indicates equal or constant atmospheric pressure.
Low pressure (L)	Shows center of low atmospheric pressure.
Stationary front	Shown as an alternating red-blue line with triangles and semi-circles. Displays a boundary between warm and cold air masses.
Warm front	Shown as a red line with red semi-circles. Displays the leading edge of a warm air mass. The semi-circles show the forward direction of the front.

## DISPLAY LAST WEATHER UPDATE

1. With the weather map displayed, select the option button on the right side of the screen.
2. Select **Update Information**. The radio shows the date and time for the last update to the radar and weather front information.

*NOTES*

142 SiriusXM



## NAVIGATION

Navigation features are available on 6.5 systems in select regions. To prevent distraction while riding, plan trips and select destinations before riding the motorcycle.

The navigation system can route to address entries, phone book contacts, point of interest (POI) destinations in the navigation database, destinations imported by Ride Planner ([www.h-d.com/rideplanner](http://www.h-d.com/rideplanner)) or by manually selecting locations on the touchscreen map.

See Figure 109. Press the NAVIGATION switch on the faceplate or select **Home** > **Nav** to access the navigation menu.

**Map:** Shows map with current location.

**POI:** Search for points of interest (gas stations, restaurants, entertainment, and so on).

**Dealership:** Search for dealerships and other Harley-Davidson facilities.

**Where To...:** Navigate to a selected address, saved location, home address, phone book contact, trips, trails or geographical coordinates.

**Recent:** Navigate to a recently selected destination.

**Emergency:** Search for a nearby hospital, police station or fire department.

**Menu:** Display current GPS information. Import and export navigation files.

## NOTES

- *There will be a slight delay after the vehicle or the radio has been powered on while the navigation system initializes. Wait until the system has finished the initialization process before using the navigation system.*
- *There may be some limitations when operating the navigation system in buildings or underground structures (such as tunnels or underground parking).*

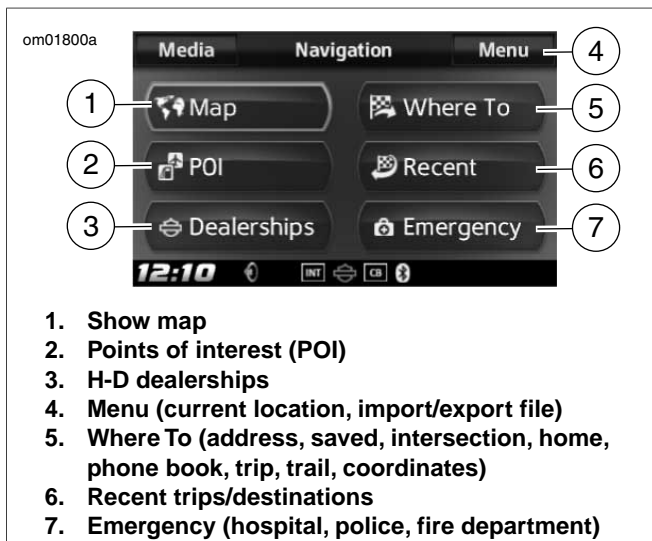

Figure 109. Navigation Menu

## DISPLAYING THE MAP

**Display map (using faceplate switch):** Press the NAVIGATION switch on the radio faceplate to display the navigation

menu. Press the NAVIGATION switch again to toggle between the navigation menu and the map.

**Display map (using menus):** Select **Home > Nav > Map**.

**Display map (using voice recognition):** Press the VOICE RECOGNITION switch. Say **SHOW MAP** into the microphone.

**Map options:** Select option button to show menu of navigation options.

**Data fields:** Select left or right data fields to change the information shown in these fields.

**Current audio source:** Select the bar to access current audio source screen (tuner or media). Press and hold the NAVIGATION switch on the radio faceplate to toggle the audio source field on or off.

**Next turn guidance:** Shows distance and turn information. Press the field to display a list of guidance instructions or avoid an upcoming road.

### NOTE

See *NAVIGATION, Changing Map Display for additional adjustments to the map display.*













- |                                     |                                  |  |
|-------------------------------------|----------------------------------|--|
| <b>1. Current street</b>            | <b>5. Map/navigation options</b> | <b>9. Next turn maneuver</b>                         |
| <b>2. Lane guidance</b>             | <b>6. Right data field</b>       | <b>10. Distance to next turn</b>                     |
| <b>3. Repeat voice instruction</b>  | <b>7. Current position icon</b>  | <b>11. Left data field (or current audio source)</b> |
| <b>4. Compass/heading indicator</b> | <b>8. Next turn guidance</b>     | <b>12. Zoom controls</b>                             |

Figure 110. Navigation Map

**Table 23. Map Components**

ICON	COMPONENT	DESCRIPTION
	Yellow flag	Waypoint (intermediate destination)
	Checkered flag	Destination
	Bright orange line	Active highlighted route
	Bright green trailing line	Recorded trail
	Blue caption	Point of interest (zoomed in)
	Blue dot	Point of interest (zoomed out)
	Boxed arrows	Lane guidance (larger orange arrows show suggested lanes)
	Road signs	Shows highway number or road name

**Table 24. Roads and Transportation**

COMPONENT	DESCRIPTION
Blue line	Ferry
Dashed line (gray/white)	Train tracks
Orange-yellow line (thick)	Freeway or tollway
Red line	Bridge or overpass
White line	Minor road
Yellow line (medium thickness)	Major road

**Table 25. Terrain**

COLOR	DESCRIPTION
Blue	Water
Light gray	Airport/seaport
Dark gray	Industrial/business
Light green	Park
Dark green	Forest
Orange	Desert
Red	Hospital/medical facility
Yellow	Mountain or desert

## CHANGING MAP DISPLAY

Map features can be turned on, off or adjusted.

1. Select **Home > Setup > Navigation Setup > Appearance**.
2. **POI icons:** Check the POI items to be displayed on the map.
3. **2D/3D map:** Select 2D map (top-down view) or 3D map (orientation is angled behind the motorcycle).

4. **North up/heading up (2D view only):** Displays the map with north toward top, or rotates the map so the vehicle heading is always oriented upward in the map. 3D view is always shown in a heading up orientation.
5. **Current street:** Displays the current street along the top of the map.
6. **Next street:** Displays the next turn at the bottom of the map.
7. **Lane guidance:** Displays lane guidance arrows along the highlighted route. When a turn is required on a multi-lane highway, the map displays bright orange arrows to suggest the proper lanes. Graphical representations of signposts and junctions are displayed.
8. **Audio info:** Displays the current audio source along the bottom of the map.
9. **Left and right data fields:** Displays the left and right data fields.
10. **Speed and flow (traffic only):** Displays traffic overlay colors on the map.
11. **Motorcycle icon:** Changes the icon used for the current position.

## NOTE

The current audio source can also be toggled on and off by pressing and holding the NAVIGATION switch on the faceplate.

## CHANGING DATA FIELDS

1. With the map displayed, select the left or right data field.
2. Refer to Table 26. Choose an option from the list to display in the field. Many of the data field settings (such as Time to Via or Arrival Distance) are only relevant during an active route.
3. Select **Back** to display the map.

**Table 26. Data Field Options**

DATA FIELD OPTIONS		
Arrival Distance	Moving Time	Time To Turn
Arrival Time	Overall Average Speed	Time To Via
Clock	Speed	Total Time
GPS Accuracy	Stopped Time	Via Distance
Heading	Temperature	

## NAVIGATION OPTION MENU

The navigation option menu button is displayed on the right side of the map. The following options are available when selecting this button.

**POIs Near:** Equivalent to selecting POIs from Navigation Main menu.

**Appearance:** Equivalent to selecting Appearance from the Navigation Setup menu.

**Trip Summary:** This screen provides information for a current trip (start and end time, average speed, fuel used and mileage, if available).

**Record On:** Records a trail of the current ride. See NAVIGATION, Trails.

**Compass:** Displays the Compass screen.

**Weather (if available):** Displays a weather overlay on the map (requires SiriusXM module with subscription to weather map service).

## ROUTE PREFERENCES AND AVOIDANCES

Preferences can be chosen for the path and type of roads to be used during route calculation (scenic, fastest, shortest or twisty). Selections can also be made to avoid specific types of

roads or routes during a calculation (such as ferries or toll roads).

1. Access the route calculation preferences. Any of the three following methods may be used.

**Navigation setup menu:** Select **Home > Navigation Setup > Route Calculation**.

**During route calculation:** Select option button. Select **Route Calculation**.

**During active route:** Select option button on the map. Select **Preferences**.

2. Select the type of path (scenic, fastest, shortest or twisty).
3. Select **Avoidances**. Check the items to avoid. Refer to Table 27.

**Table 27. Avoidances**

<b>SELECTIONS</b>
Highway
Toll road
Ferry
In-process data (IPD)
Car/train
Unpaved road
Time restriction
Seasonal restriction
Border

## **COMPASS**

### **Compass/Heading Indicator on Map**

See Figure 111. A compass or heading indicator is displayed in the upper right corner of the map. The icon operates differently according to the map orientation setting (north up or heading up).

**North Up:** The red compass needle is always pointed north. The vehicle icon rotates while riding.

**Heading Up:** The needle rotates to the direction of the vehicle (north, south, east, or west). For example, when heading east, the red needle points to the right (east).

**NOTE**

*While on other screens, the system displays the current heading in the status bar.*

### Full Size Compass

A full sized compass can also be displayed to show vehicle heading.

1. With map displayed, select the options button.
2. See Figure 112. Select **Compass**.

**NOTES**

- *For some regions that do not support navigation or mapping features on the 6.5 radio, pressing the NAVIGATION switch on the faceplate will display the full size compass.*
- *The motorcycle must be in motion to determine the current heading. If the current heading is not known, the full size compass will display question marks.*

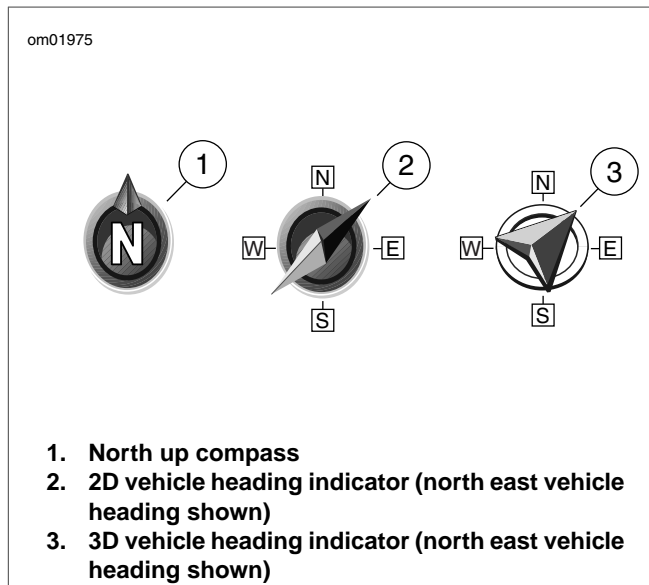

**Figure 111. Compass/Vehicle Heading Indicator**



Figure 112. Compass

## MAP SCROLLING (TOUCHSCREEN)

1. With the map displayed, press on the touchscreen. The scrolling tool (circle with arrows) is shown on the map. The title bar displays the name of the street that is currently being viewed.
2. **Scroll:** Press and hold the screen arrows to scroll.  
**Jump:** Press another location on the map to jump.
3. **Route to location:** Select the center circle to route to the location on the map.

**End scrolling:** Select the Back button to end scrolling and return to the current position on map.

## MAP SCROLLING (HAND CONTROLS)

1. See Figure 113. With the cursor in the top title bar, press and hold the CURSOR/SELECT hand control switch until the scrolling tool is displayed.
2. Select an arrow with the CURSOR/SELECT switch. Press and hold to begin scrolling.
3. **Route to location:** Select the center circle to route to the location on the map.
4. **End scrolling:** Select the **Back** button to end scrolling and return to the current position on map.

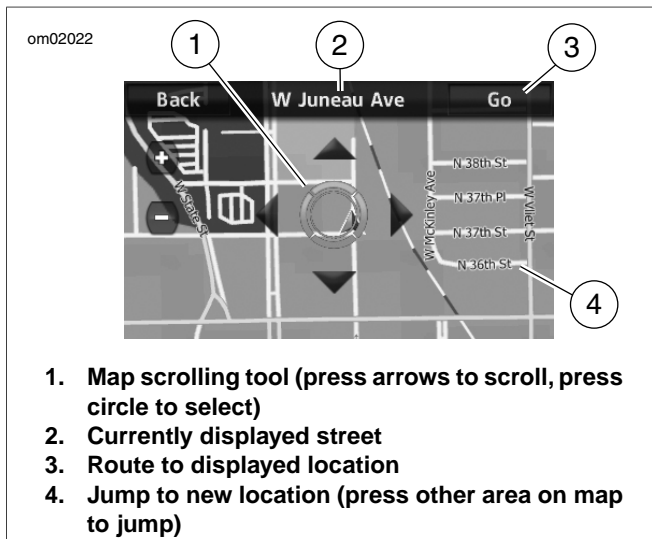

Figure 113. Map Scrolling

## SELECTING POI ON MAP

POI icons are only visible on the map at closer zoom levels. See NAVIGATION, Changing Map Display to change the types of POI icons that are displayed on the map.

1. See Figure 114. Scroll to a POI icon on the map. Zoom close to the icon.
2. Refer to Table 28. With the center circle on the POI, select the POI location. The radio calculates a route to the selected POI. If multiple POIs are in the same location, the system will prompt with a list of POIs.
3. Select the option button to show more options for the POI. Otherwise, select **Go** to begin route.

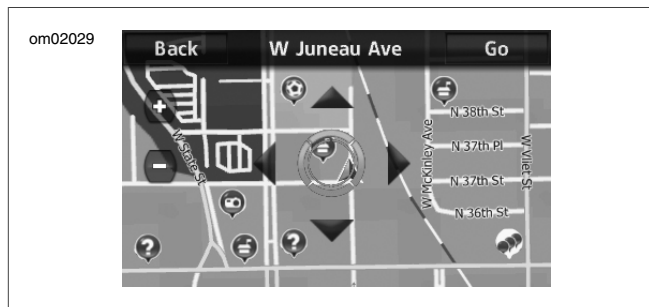



















Figure 114. Selecting POI On Map



**Table 28. POI Icons**

ICON	DESCRIPTION
	ATM/Banking
	Automotive
	Coffee shop
	Community
	Entertainment
	Gas station
	Harley-Davidson
	Health and beauty
	Highway exit

**Table 28. POI Icons**

ICON	DESCRIPTION
	Hospital
	Hotel/motel
	Other
	Parking
	Recreation
	Restaurant
	Shopping
	Travel
	Truck stop

## ROUTE TO DESTINATION (ADDRESS)

1. See Figure 115. Select **Home > Nav > Where To**.
2. Select **Address**.
3. See Figure 116. Enter the address into the fields.
4. Select **OK**.

### NOTES

- The system will use the smart speller to narrow entries according to the contents of the navigation database.
- The system will provide lists of possible destinations based on the input. For example, entering "Birch Street" will generate a list of all cities with a "Birch Street" in the database.
- As a minimum, the system requires either a postal code or a city and state. If a street address is not entered, the system will navigate to the city center. Requirements may vary slightly according to region.

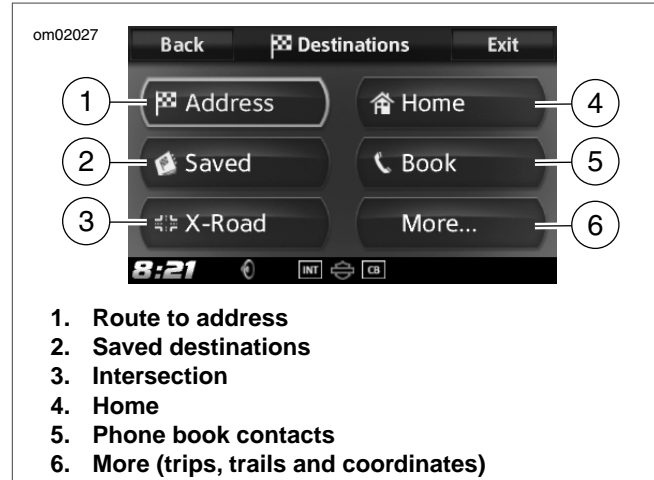

Figure 115. Where To Screen



Figure 116. Address Screen

## ROUTE TO DESTINATION (HOME)

The Home destination can be used to quickly set up a route back to home from any location.

1. Select **Home** > **Nav** > **Where To**.
2. Select **Home**.
3. **Home has been programmed:** The system will calculate a route to the home destination. Select **Go**.

**Home has not been programmed:** Select a home destination (address, recent destination, or so on). The destination will be used for all future home routing. To save

your current destination as home, see NAVIGATION, Saving Current Location.

### NOTES

- To delete or change the home destination, activate a route to home and select the option button on the map. Select **Delete Destination**. Repeat steps to program a new home destination.
- Once a home address has been saved, a voice command can also be used to navigate home. Press the VOICE RECOGNITION switch and say **HOME** into the microphone.

## ROUTE TO DESTINATION (RECENT)

1. Select **Home** > **Nav** > **Where To**.
2. Select **Recent**. The system displays a list of up to 99 recent destinations (without including duplicates).
3. Select a recent route from the list.
4. Select **Go**.

## NOTES

- *To delete all recent destinations from the list, select the trash can button.*
- *To add a recent destination to the saved list, select the option button and select **Save**.*

## ROUTE TO DESTINATION (PHONE BOOK)

The system can navigate to phone book addresses stored on a connected phone or saved locally in the radio.

1. Select **Home > Nav > Where To**.
2. Select **Book**.
3. **If phone connected:** Select **Saved on Radio** (to display phone contacts from the saved list) or **On Connected Phone** (to use the phone book on a connected phone).  
**If phone is not connected:** The radio will display contacts that have been saved to the radio. See PHONE, Saving a Phone Book Contact.
4. If prompted, enter any missing information in the address.
5. Select **OK** to calculate the route. Select **OK** again to start navigation.

## ROUTE TO DESTINATION (SAVED)

After a destination has been saved, it can be used for future rides. See NAVIGATION, Saving a Destination (Saved, Preferred or Home).

1. Select **Home > Nav > Where To**.
2. Select **Saved**.
3. Select saved destination from the list.
4. Select **Route/View**.
5. Select **Go**.

## ROUTE TO DESTINATION (MAP SCROLL TOOL)

1. With the map displayed, press on the touchscreen to activate the scrolling tool.
2. Scroll to a location or POI.
3. Select the center circle to route to the location or POI on the map.
4. Select **Go**.

## ROUTE TO DESTINATION (POI)

The system can route to points of interest stored in the navigation database.

1. Select **Home > Nav > POI**.
2. See Figure 117. Select the location for the POI. Choose from the following options:

**Near Location:** shows POIs near your current location.

**Around a City:** shows POIs near a particular city. Enter the city name.

**Along Route:** shows POIs along the active route.

**Near Destination:** shows POIs near the destination (during active route).

3. Select one of the four options to find the POI.
  - Category:** Browses through a list of categories. Refer to Table 28.
  - Preferred:** Displays a list of POIs that have been saved as preferred destinations (such as a particular restaurant chain or gas station brand). The system will search for the same preferred chain or brand within the selected area. See NAVIGATION, Saving a Destination (Saved, Preferred or Home).

**Spell Name:** Use the keyboard to enter a full or partial name of the POI. The system displays matching POIs in the selected area.

**Phone Number:** Enter a phone number for the destination. The system will display POIs with that phone number in the selected area.

4. **Toggle distance/name:** The list of POIs is displayed in order of distance. Select the reorder button on the right side of the screen to display the list by alphabetical order or by distance from current location.
5. Select a POI from the list.
6. Select **Go**.

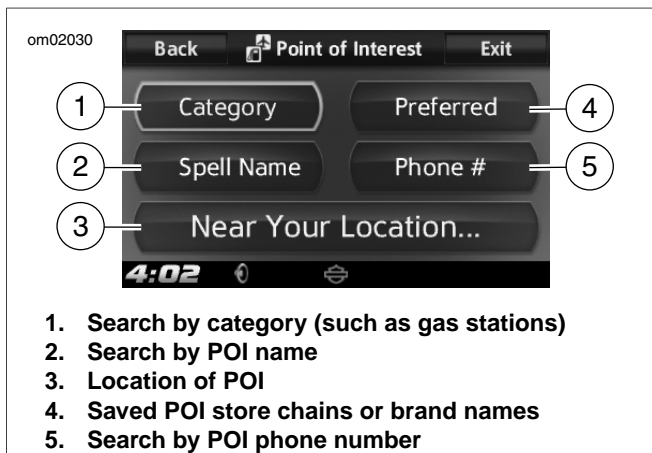

Figure 117. Route To Destination (POI)

## ROUTE TO DESTINATION (DEALERSHIP)

The navigation database includes dealerships and other Harley-Davidson facilities (such as the Harley-Davidson Museum).

1. Select **Home > Nav > Dealerships**.
2. Select a location from the list.

3. Select **Go**.

## ROUTE TO DESTINATION (EMERGENCY)

*NOTE*

*In case of emergency, contact the facility to verify their availability before proceeding.*

1. Select **Home > Nav > Emergency**.
2. Select **OK** to acknowledge the alert.
3. Select **Hospital, Police** or **Fire Department**.
4. Select a location from the list.
5. See Figure 118. Select **Go**.



Figure 118. Route To Destination (Emergency)

## ROUTE TO DESTINATION (COORDINATES)

1. Select **Home** > **Nav** > **Where To**.
2. Select **Geo**.
3. See Figure 119. Use the multiselect button to adjust the format for the coordinates if necessary. The formats can

include heading (h) such as North, degrees (d), minutes (m), and seconds (s).

- a. **h ddd.dddddd°**
- b. **h ddd° mm" ss.s'**
- c. **h ddd° mm.mmm'**

4. Enter the latitude and longitude coordinates.
5. Select **OK**.

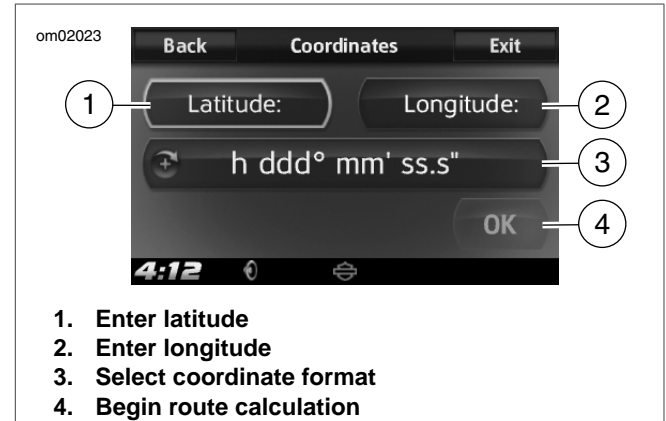

1. **Enter latitude**
2. **Enter longitude**
3. **Select coordinate format**
4. **Begin route calculation**

Figure 119. Route To Destination (Coordinates)

## ROUTE TO DESTINATION (SIRIUSXM FUEL PRICES FEATURE)

For vehicles equipped and subscribed to the SiriusXM Fuel Prices feature, routing can be made to a nearby gas station based on current fuel prices. See SIRIUSXM, SiriusXM Fuel Prices.

## ROUTE TO DESTINATION (VOICE COMMAND)

1. With route active, press the VOICE RECOGNITION switch.
2. **Route to address:** Say **DESTINATION** followed by the address into the microphone.  
**Route to saved destination:** Say **FAVORITE** followed by the saved destination name into the microphone.  
**Route to POI:** Say **FIND NEXT** followed by the type of destination or brand name (such as **BANK** or **GAS STATION**).

## CANCELING A ROUTE (USING MENUS)

1. While the map is displayed, select the option button.
2. Select **Stop**.

### NOTE

*When selecting a new route, the system provides a notification to either add or replace the existing route. There is no need to manually cancel the current route when adding or replacing it with a new route.*

## CANCELING A ROUTE (VOICE COMMAND)

1. With route active, press the VOICE RECOGNITION switch.
2. Say **CANCEL ROUTE GUIDANCE** into the microphone.

## TRIPS

Trips are useful when visiting a number of POIs during an extended ride, planning rides with intermediate destinations (waypoints), or when planning a ride with restaurants and overnight lodging. A total of 17 trips can be stored in the system.

Each trip can include up to 9 destinations. If an upcoming ride requires more than 9 destinations, consider creating separate trips for each leg of the ride (with the first trip including the first 9 destinations, and so on).

A trip can be created using the navigation menus or by creating a trip on the map screen. Trips can also be imported from Ride Planner. See NAVIGATION, Importing a Route.



## CREATING A TRIP (USING MENUS)

1. Select **Home** > **Nav** > **Where To**.
2. Select **Trip**.
3. Enter a name for the trip. Use a name that is easy to pronounce when using voice recognition features. Select **OK**.
4. Enter a destination (address, POI, recent destination, saved location or intersection).
5. Select **Add**. When prompted to add more destinations, select **Yes** to add more destinations, or select **No** when finished.
6. The trip itinerary is displayed.
7. **To start the trip:** Select **Start**.

**To edit the trip:** Select the edit button (pencil icon). See NAVIGATION, Editing a Trip (Adding Waypoints).

## CREATING A TRIP (USING MAP)

1. With map displayed, press the touchscreen.
2. Scroll to a POI or location on the map. Select the center circle to calculate a route to the destination. Select **Go**.

3. Repeat the previous step to add more destinations to the route. Up to nine destinations can be added to a trip.
4. After all destinations have been chosen, select the option button on the map.
5. Select **Destinations**. Select the edit button (pencil) to reorder the waypoints as needed.
6. Select **Save As Trip**.
7. Enter a name for the trip. Select **OK**.

## ROUND TRIP

When the round trip function is enabled, the system calculates a return route to the original position of the vehicle. The round trip feature can only be enabled before a route is activated.

1. With no route active, access the route calculation settings.  
**From setup menu:** Select **Home** > **Navigation Setup** > **Route Calculation**.  
**During route calculation:** Select option button. Select **Route Calculation**.
2. Check the **Round Trip** checkbox. When a new route is created, the map will include a return route back to the original location of the vehicle.

## EDITING A TRIP (ADDING WAYPOINTS)

1. With a trip selected, press the edit button (pencil).
2. Select **Add Destination**.
3. Enter a destination (address, POI, recent destination, saved location or intersection).
4. Select **Add**. When prompted to add more destinations, select **Yes** to add more destinations, or select **No** when finished.
5. The trip itinerary is displayed.

## EDITING A TRIP (REORDERING WAYPOINTS)

1. With a trip selected, press the edit button (pencil).
2. Select **Reorder**.
3. See Figure 120. Select a destination to reorder.
4. Select the reorder button on the right side of the screen. The item being moved will be highlighted.
5. Select the place to move the highlighted item. The item will be moved *before* the selected place (if higher on the list) or *after* the selected place (if lower on the list).

6. Change the order of other destinations as needed. When finished, select **Back**.

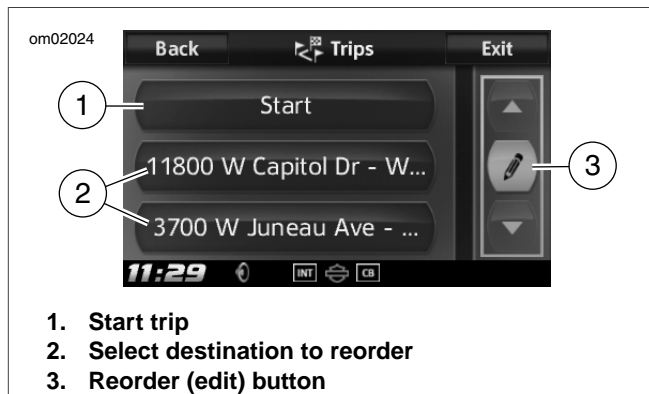

Figure 120. Editing a Trip (Reordering Waypoints)

## EDITING A TRIP (SKIPPING WAYPOINTS)

1. With active route on the map, select the option button.
2. Select **Destinations**.
3. Select the destination to skip.

4. Select the options button.
5. Select **Stop**. The system removes the waypoint from the current route. However, the waypoint is not removed from the originally stored trip.

## TRAILS

See Figure 121. A trail is a specific path which is recorded during your ride. While the trail is recording, the system stores ongoing location points along the ride. This is different than saving a destination or trip, which only store a number of locations rather than a specified path.

A trail can be used to repeat the ride along the same path in the future, or to route back to the start of the trail using the same path.

A trail can be recorded at any time. A route does not need to be active to begin recording a trail.

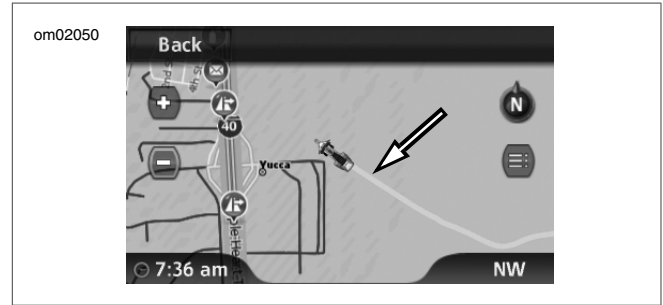

Figure 121. Recording a Trail

## RECORD A TRAIL (OPTIONS MENU)

1. With the map displayed, select the option button.
2. **Start trail:** Check the **Record On** checkbox. The trail begins recording.
3. **End trail:** Uncheck the **Record On** checkbox. The trail stops recording and is stored in the list of trails.

## RECORD A TRAIL (TRAILS MENU)

1. From the Navigation menu, select **Where To > More > Trails**.

2. **Start trail:** Select **New**. If a previous trail was being recorded, it is saved to the trail list. The new trail begins recording.
3. **End trail:** Uncheck the **Record On** checkbox. The trail stops recording and is stored in memory with the current date and time.

## RENAME A TRAIL

The system names trails as "tri" followed by a string of numbers. Trails can be renamed with more meaningful names.

1. From the Navigation menu, select **Where To > More > Trails**.
2. Select the trail from the list.
3. Select **Rename**.
4. Use the keyboard to enter a new name for the trail. Select **OK**.

## NAVIGATING A TRAIL

A trail can be used to ride the originally recorded route (from start to end) or a return route (from end to start). When selecting a trail, the route will include navigation from your current location to the beginning of the trail.

1. From the Navigation menu, select **Where To > More > Trails**.
2. Select the trail from the list.
3. **Take original route (start to end):** Select Route to End.  
**Take return route (end to start):** Select Route to Start.

## DELETING A TRAIL

1. From the Navigation menu, select **Where To > More > Trails**.
2. Select the trail from the list.
3. Select the trash can button.
4. Select **Yes** to confirm.

## EXPORTING A ROUTE

A trip, trail or saved destination can be exported to a USB storage device. The system exports the set of routes as a GPX file named "H-D\_NavData.gpx". If needed, the system will add a sequential number to prevent overwriting other previously saved files (such as "H-D\_NavData(1).gpx"). Multiple trips or destinations can be contained in a single GPX file.

The export feature is designed to back up routes or share routes with other riders that have a Boom! Box system. While

the GPX file may be imported into other GPS devices, there may be limitations on compatibility.

1. Connect a USB device to store the files. The USB device must be formatted to FAT16 or FAT32 (typical format used by PCs) to support data exports. NTFS-formatted devices are read-only and do not support GPX export.
2. From the Navigation menu, select **Menu**.
3. Select **Export**. A list of trips, trails and saved destinations are displayed.
4. Check the checkboxes for all items to be exported, or choose **Select All**.
5. Select the USB Export button on the right side of the screen.
6. Select **OK** when the export completes. The USB device can be removed.

## IMPORTING A ROUTE

The system can import trip, trail and destination files saved in GPS Exchange Format (GPX). The files may have been exported by another motorcycle equipped with a Boom! Box system or created by Ride Planner ([www.h-d.com/rideplanner](http://www.h-d.com/rideplanner)). A single GPX file may contain multiple trips and destinations.

The system can use GPX files exported by other GPS devices or mapping websites. While GPX is a standard format for navigation files, there may be some limited compatibility when importing these routes. Review the route before riding.

Imported routes are stored in respective locations within the radio. Destinations are stored in the Saved list. Imported trips are stored in the Trips list. Imported phone book contact files (V-card files, VCF) are added to the Book list in the navigation menu.

### NOTE

*The system only supports up to 9 destinations per trip. If an imported trip includes more destinations, the additional destinations will be cut off. If necessary, create a separate trip for each leg of the ride (with the first trip including the first 9 destinations, and so on).*

1. Connect a USB device to store the files.
2. From the Navigation menu, select **Menu**.
3. Select **Import**. A list of GPX and VCF files are displayed.
4. Select a GPX or VCF file from the list. A list of all trips, trails and destinations within the GPX file are displayed.
5. Select the trips, trails and destinations to import.
6. Select the **Import** button on the right side of the screen.

7. Select **OK** when completed. The USB device can be removed.

## EXPORTING A RIDE PLANNER ROUTE

1. Connect a USB drive to the computer. The USB drive must be formatted to FAT16 or FAT32 (commonly used by most PCs).
2. Open Ride Planner ([www.h-d.com](http://www.h-d.com) > **Owners** > **Ride Planner**).
3. Create a new route or select an existing route (H-D Great Road, rider-submitted road or personally saved road).
  - a. See Figure 122. Add locations for major destinations, such as the start point and end point.
  - b. Add waypoints for other minor stopping points or desired roadways to be traveled.
4. Select **GPS Sync**.
5. Select **Manual Mode**.
6. Select **Save As GPX File**.
7. Add a unique name for the route, and select **Export Stops and Waypoints**.
8. Save the GPX file to the USB drive. By default, Ride Planner will name the file as "HDRoute.gpx". Rename the file to a unique name as necessary.
9. Remove the USB drive and import the file into the radio. See NAVIGATION, Importing a Route.

### NOTES

- See Figure 123. Ride Planner exports each pair of locations as a separate trip (even though the entire Ride Planner route is exported as a single GPX file). In the example, the route from Location 1 to Location 2 (with the intermediate waypoints) is exported as a trip. The route from Location 2 to Location 3 is exported as a separate trip.
- The Boom! Box navigation system does not differentiate between locations and waypoints. All items are imported as destinations. When plotting a route, remember that each trip can only include a total of nine destinations.
- Ride Planner exports locations and waypoints into the GPX file. It does not export the highlighted route. The exact routing between destinations may be calculated differently within the radio than shown in Ride Planner. To plot a particular path, you may need to add waypoints along the desired route. Also, the route calculation can be affected by system settings such as route preferences

(scenic, fastest, shortest or twisty) and avoidances (such as toll roads, unpaved roads and so on). See NAVIGA-

TION, Route Preferences and Avoidances.

om02058

**1. Locations**

**2. Waypoints**

**3. GPS Sync (export to GPX file)**

Figure 122. Ride Planner

om02059

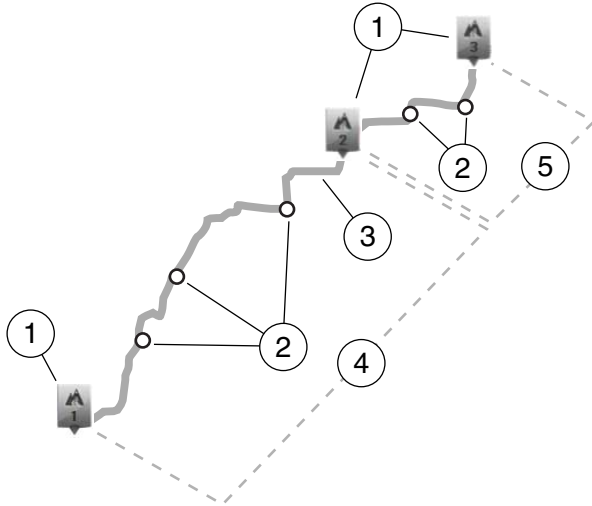

1. Locations
2. Waypoints
3. Highlighted route (not exported)
4. Exports into GPX file as first trip
5. Exports into GPX file as second trip

Figure 123. Ride Planner Example

## MANEUVERS (TURN-BY-TURN INSTRUCTIONS)

1. See Figure 124. While a route is active, select the next turn displayed at the bottom of the map. A list of all turns in the route are displayed.
2. Selecting a maneuver will provide the following options:
  - Avoid:** The system will calculate new directions to avoid the selected road.
  - Zoom:** The map will display the selected maneuver on the map.
  - OK:** Returns to the list of maneuvers.
3. To restore an avoided road, select the Avoided Segments button. Select the avoided turn from the list. See NAVIGATION, Restoring an Avoided Road.





Figure 124. Maneuver List (Turn-By-Turn Instructions)

## DISPLAYING A MANEUVER (ZOOM)

1. Select the next turn displayed at the bottom of the map. A list of all turns in the route are displayed.
2. Select a road from the list.

3. See Figure 125. Select **Zoom**. The map shows the maneuver, with details on the bottom of the screen.
4. **Return to list:** Select **Back** button.  
**Display previous/next maneuver:** Select previous/next maneuver buttons on screen.  
**Avoid the road:** Select Avoid/Restore button.

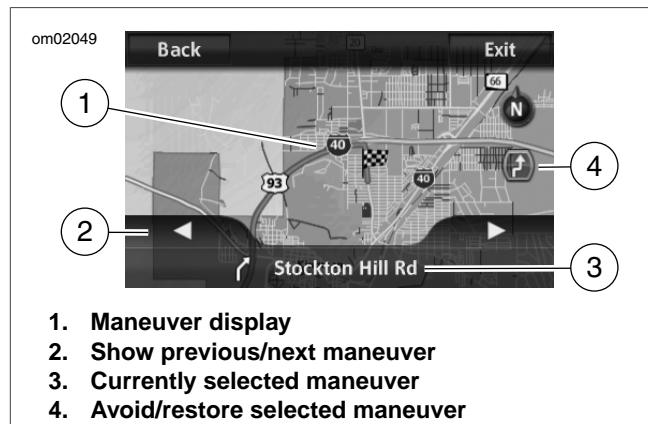

Figure 125. Displaying a Maneuver (Zoom)

## AVOIDING A ROAD

1. Select the next turn displayed at the bottom of the map. A list of all turns in the route are displayed.
2. Select a road from the list.
3. Select **Avoid**.
4. Select **Yes** to confirm. The system calculates new directions to avoid the selected road.

## RESTORING AN AVOIDED ROAD

1. Select the next turn displayed at the bottom of the map. A list of all turns in the route are displayed.
2. See Figure 124. Select the **Avoided Segments** button. A list of all avoided roads is displayed.
3. Select the road to be restored. The system displays a map of the maneuver.
4. See Figure 125. Select the **Avoid/Restore** button on the right side of the map.
5. Select **Yes** to confirm. The system recalculates directions. The restored road is considered in the calculation.

## LANE GUIDANCE

See Figure 126. When an upcoming turn or road divergence is required on a multi-lane highway, the map displays lane guidance arrows to suggest the proper lanes to use. Safely change to the suggested lane and follow the direction of the bright orange arrows.

See Figure 127. When approaching the turn, the system shows a representation of the signposts and upcoming road junction. Continue to follow the guidance of the bright orange arrows.

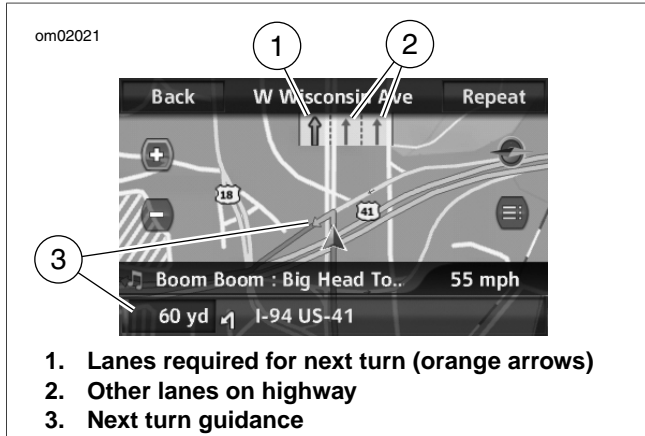

Figure 126. Lane Guidance



Figure 127. Signpost and Junction View

## SAVING A DESTINATION (SAVED, PREFERRED OR HOME)

A destination can be added to the saved list or defined as the home destination.

1. Select a destination (such as a POI, address, recent destination or GPS coordinate).
2. After the route is calculated (but before selecting Go), select the option button.
3. Select **Save**.

4. **Add to Saved list:** Select **Saved**. Enter a name for the currently selected location. Select **OK**. See NAVIGATION, Route To Destination (Saved).

**Add to Preferred list (POIs only):** Select **Preferred**. Instead of saving a specific destination, the system saves the POI (such as a particular restaurant chain or gas station brand). The system can later search for the same preferred chain or brand when riding in other locations. See NAVIGATION, Route To Destination (POI).

**Set as Home destination:** Select **Home**. The current location is stored as your home destination. See NAVIGATION, Route To Destination (Home).

## SAVING CURRENT LOCATION

The current location can be stored to the Saved destination list, or configured as the home destination.

1. Select **Home > Nav > Menu**.
2. Select **Location**. The current GPS coordinates and signal strength are displayed. Address is displayed if available.
3. Select the option button.
4. Select **Save**.

5. **Add to Saved list:** Select **Saved**. Enter a name for the current location. Select **OK**. See NAVIGATION, Route To Destination (Saved).

**Set as Home destination:** Select **Home**. The current location is stored as your home destination. See NAVIGATION, Route To Destination (Home).

## SHOWING A PLANNED ROUTE

An entered route can be displayed before committing to the route.

1. When a destination has been selected, select the option button (before pressing Go).
2. Select **Show Route**. The map shows the entire highlighted route.
3. To commit to the route, select the **Back** button twice. Select **Go**.

## SIMULATING A ROUTE

A route simulation can be viewed before committing to the route. The route simulation can only be used while the motorcycle is not moving.

1. When a destination has been selected, select the option button (before pressing Go).

2. Select **Simulate Route**. The route simulation will be played on the map. Audible turn guidance will also be played.
3. To exit route simulation, select the **Back** button.
4. To commit to the route, select the **Back** button again. Select **Go**.

## CALLING A DESTINATION (ROUTE ACTIVE)

There are occasions when calling a destination may be helpful (to determine operating hours or get information).

1. With a phone connected and the route active on the map, select the option button.
2. Select **Destinations**.
3. Select the option button.
4. Select **Call**. Select **OK** to confirm.

## CALLING A DESTINATION (ROUTE NOT ACTIVE)

1. With a phone connected, select a destination (such as a POI).
2. After the route is calculated (but before selecting Go), select the option button.

3. Select **Call**. Select **OK** to confirm.

## TRIP SUMMARY

A summary of the current route can be displayed at any point during a ride. The summary shows start and end time, mileage information and other data.

1. During an active route, select the option button on the map.
2. See Figure 128. Select **Trip Summary**.

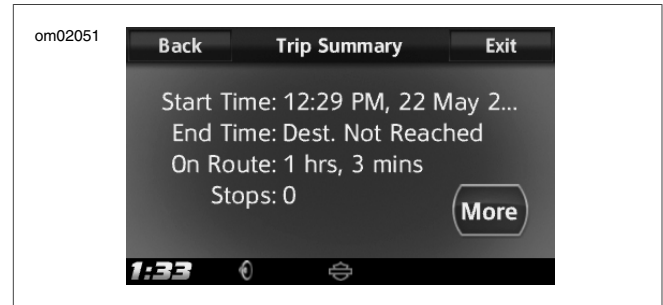

Figure 128. Trip Summary

## LOW FUEL ALERT

See Figure 129. When the vehicle detects low fuel, the radio shows an alert and prompts with a list of nearby gas stations. The low fuel alert automatically displays even when the radio is turned off.

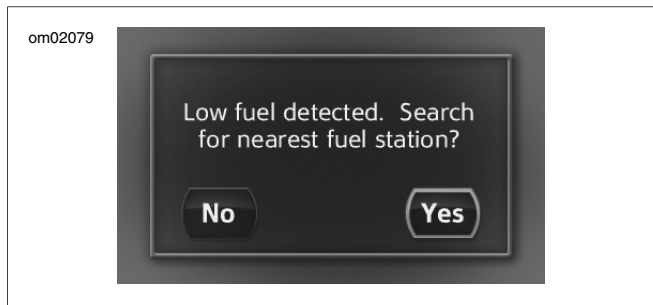

Figure 129. Low Fuel Alert

## GPS INFORMATION

1. Select **Home** > **Nav** > **Menu**.

2. Select **Location**. The system displays the GPS signal strength, coordinates and address for the current location (if available) as shown in Figure 130.
3. Select the option button.
4. Select **GPS**. The system displays coordinates, elevation, signal and position information as shown in Figure 131.

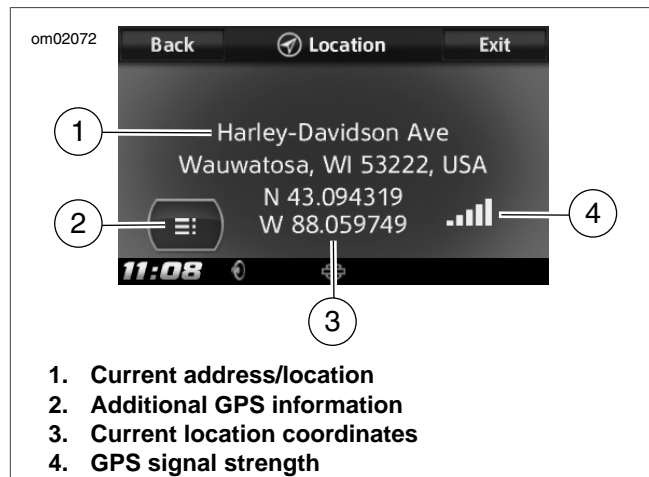
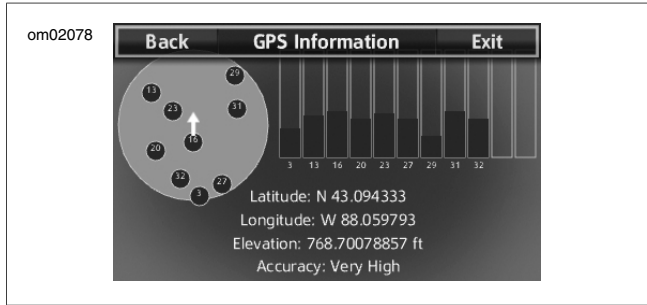

Figure 130. GPS Location



**Figure 131. GPS Information**

## TRAFFIC

See Figure 132. The navigation system can provide traffic information when RDS Traffic (TMC) or SiriusXM Traffic is equipped on the vehicle and available in the region. When traffic is enabled, the map shows traffic flow and events along the currently selected route. Refer to Table 29 for traffic icon descriptions.





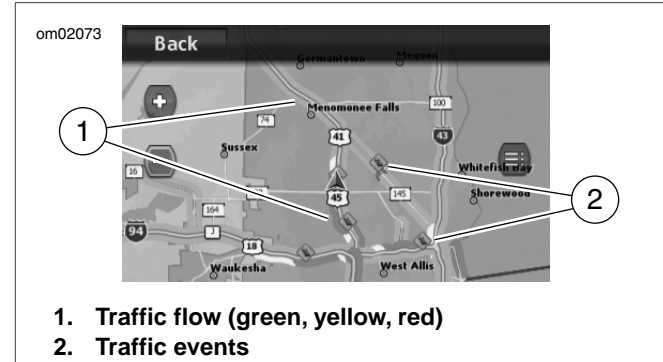











The system also stores a list of all traffic events that are nearby or along the active route. When an event (such as an accident or lane closure) is discovered along the current route, the navigation system notifies of the event and may attempt to

calculate an alternate route. The system will either prompt to make the change or will automatically adjust the route, according to the system settings.



**Figure 132. Traffic**

**Table 29. Traffic Conditions**

ICON	DESCRIPTION	ICON	DESCRIPTION
	Free flowing traffic		Heavy traffic
	Slow traffic		Accident
	Stopped traffic		Construction
	Slippery		Narrow
	Weather		Warning
	Wind		Blockage
	Frost		Security checkpoint
	Traffic		Information

## TURNING TRAFFIC ON/OFF

On equipped vehicles, traffic automatically turns on when selecting the RDS traffic feature from the Home screen, or when selecting the SiriusXM traffic feature.

1. Select **Home > Setup > Traffic**.
2. Check the **Traffic** checkbox to turn on.

## TRAFFIC NOTIFICATION SETTINGS

1. Select **Home > Setup > Traffic > Notification**.
2. **Beep when traffic popup is displayed:** Check **Popup Beep** checkbox.
3. **Traffic event range:** Select **Message Filter**. Choose the maximum distance of traffic events to be displayed in the event list.

## REROUTING

The system can be configured to manually or automatically select a new route based on traffic data. The system will only provide a new route when it is calculated to be at least five minutes faster than the current route.

1. Select **Home > Setup > Traffic**.
2. Choose the rerouting setting.



**Automatic:** The system will automatically adjust the route according to traffic data.

**Manual:** The system will provide a popup when a new route is suggested. The rider can choose to accept or reject the recalculated route.

**Off:** The system will not prompt with any new routes based on traffic data.

## TRAFFIC EVENT LIST (RDS TRAFFIC)

### NOTE

For SiriusXM traffic, see *SIRIUSXM, SiriusXM Traffic*.

1. See Figure 133. Select **Home** > **Traffic**. If a route is active, the system will show traffic events along the route. If a route is not active, the system will show all nearby traffic events.
2. Select an item from the list. The traffic message is displayed. The text to speech feature reads the message over the speakers or headset.
3. Select the map button to display the event location on the map.

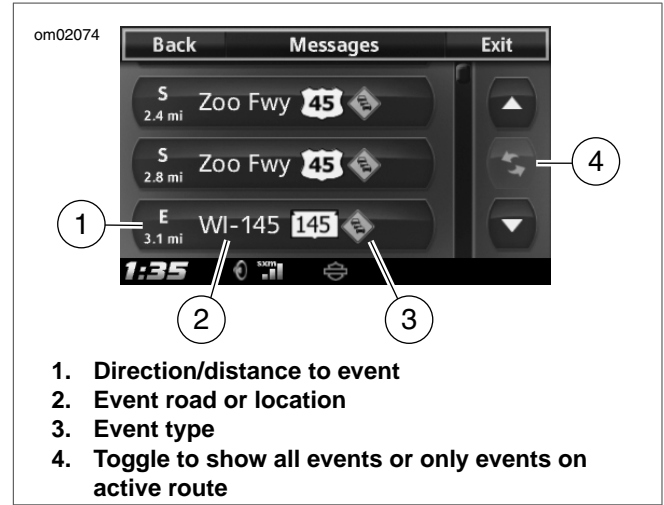

Figure 133. Traffic Event List

## NAVIGATION PROMPTS (TURNING ON/OFF)

1. Select **Home** > **Setup** > **Feedback Settings**.
2. Check or uncheck the **Enable Nav Prompts** checkbox.

## NAVIGATION PROMPTS (ADJUSTING VOLUME USING MENUS)

1. Select **Home > Setup > Feedback Settings**.
2. Adjust the prompt volume level. All prompts will be adjusted to the selected level (navigation, voice recognition, and so on).

## NAVIGATION PROMPTS (ADJUSTING VOLUME WITH HAND CONTROLS)

While a prompt is being heard, adjust the volume in the left hand controls. All prompts will be adjusted to the selected level (navigation, voice recognition, and so on).

## NAVIGATION PROMPTS (SPEAKER/HEADSET SELECTION)

1. Select **Home > Setup > Speaker/Headset**.
2. For Prompts, select **Speaker** or **Headset**. All prompts (including navigation guidance) will be played over the selected audio output.

## NAVIGATION DATABASE

Update, replacement and restoration map databases are downloaded from [harley-davidson.naviextras.com](http://harley-davidson.naviextras.com). This website can be accessed through a link on [www.h-d.com/boom](http://www.h-d.com/boom).

**Update:** Motorcycles are delivered with the latest map database. Newer database versions are periodically released and are made available for purchase.

**Intercontinental Replacement:** Riders traveling outside of their home navigation database area can purchase a replacement database which covers the intended area of travel.

**Intercontinental Restoration:** After returning from extended travel in a different continent or in a region requiring a unique database, the navigation database can be restored to its home database.

## Verifying Database Version

1. Turn ignition on.
2. Select **Home > Setup > System Information > Navigation > Database** to show the currently installed database version.
3. See Figure 134. Record the database version number.

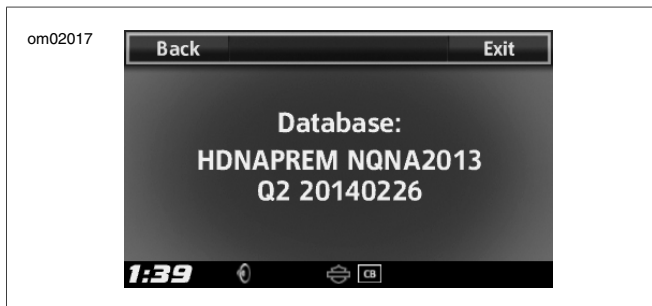

Figure 134. Navigation Database Version

## Download Hardware/System Requirements

- Downloading update, replacement or restoration databases from Naviextras requires a computer platform loaded with specific Windows operating systems and a minimum resolution display. See the Naviextras website for supported platforms and display resolution.
- A USB flash drive with a minimum of 16 GB is required. The flash drive must be able to accept database files in its root directory. Flash drives with security features or

password requirements are not suitable for transfer of database files.

- Map databases are large files. Allow sufficient time to complete all uploads, downloads, or unzipping of files. Do not interrupt an operation.

## Updating Database

### NOTES

- *The Naviextras website hosts a set of HOW-TO-GUIDE files to walk you through each step of the update procedure. Select and read the matching guide to complete each of the following tasks.*
  - *Naviextras may indicate a that a free update is available. Make sure that the update version is newer than the database version in the motorcycle before attempting to download or install the update.*
  - *For CVO models, three navigation map database updates can be downloaded for free over a five year period. Inter-continental replacements require additional charges for all models.*
1. Register with the [harley-davidson.naviextras.com](http://harley-davidson.naviextras.com) web site.

2. Install the Naviextras Toolbox Windows utility on a compatible computer.
3. Create a "fingerprint" of your Boom! Box on a USB flash drive.
  - a. Install a USB flash drive to the USB port in the storage compartment.
  - b. Go to **Home > Setup > System Information > Navigation > Export for Update**.
  - c. Select the USB flash drive from the list.
  - d. When the export for update completes, select **OK**.
  - e. Remove the flash drive.
4. Connect the USB flash drive to the PC.
5. Compare the recorded version number to those available on the website. If there is a database with the same number but with a date code later than the recorded number, continue with this process.
6. Use the Toolbox utility to login, select and purchase an available update to the navigation database. Download the database.
7. If necessary, extract or unzip any .zip files.

8. Download the unzipped updated database to the root directory of the USB flash drive.
9. Connect the USB flash drive to the USB port in the storage compartment.

*NOTE*

*The updated database automatically uploads to the Boom! Box.*

## Replacing the Intercontinental Database

*NOTE*

*The Naviextras website hosts a set of HOW-TO-GUIDE files to walk through each step of the replacement procedure.*

1. With the Naviextras Toolbox Windows utility loaded on your PC, select and download a replacement package.
2. Extract or unzip the .zip files.
3. Copy the unzipped files onto the root directory of a USB flash drive.
4. Install the USB drive to the USB port on the motorcycle.
5. Wait until the Boom! Box recognizes the USB drive. Record the "request code" displayed on the touchscreen.

6. In the Naviextras Toolbox, navigate to the code redemption page, enter the request code and complete the transaction. Record the "activation code".
7. Enter the activation code into the Boom! Box. Allow time for the Boom! Box to replace the current map database with the replacement.

## Restoring an Intercontinental Database

### NOTE

- *You can restore your original package at any time for no extra charge.*
- *Likewise, any previously purchased updates can be downloaded to the USB flash drive from the Toolbox utility.*

1. With the Naviextras Toolbox Windows utility loaded on your PC, select and download the restoration package.
2. Extract or unzip the .zip files.
3. Copy the unzipped files onto the root directory of a USB flash drive.
4. Install the USB drive to the Boom! USB port.
5. Wait until the Boom! Box recognizes the USB drive. Record the "request code" displayed on the touchscreen.
6. In Naviextras, navigate to the code redemption page, enter the request code. Record the "activation code".
7. Enter the activation code in the Boom! Box. Allow time for the Boom! Box to restore the original database.

## NOTES

## VOICE RECOGNITION

Voice recognition provides a hands-free alternative to operate many Boom! Box functions. Commands spoken into a headset microphone can instruct the system to play a media file, make a phone call, navigate to a destination, tune to a frequency or perform other features. Voice commands can be used to access functions that may be otherwise locked out while the vehicle is in motion.

To make full use of the system and to reduce distraction while riding, take time to learn voice commands for features that you commonly use.

### NOTE

- *Voice recognition on 4.3 models is only supported for phone functions. The 4.3 phone commands are available in English only. Refer to Table 33.*
- *Some vehicles do not have headset connectors. A P&A headset connection kit must be installed on the vehicle to use voice command functions.*

## ACTIVATING VOICE RECOGNITION

1. Press the VOICE RECOGNITION hand control switch. The system beeps and prompts for a command. The system shows a list of commands (teleprompter). The voice recognition icon appears in the status bar.

2. After the beep, speak a command into the headset microphone.

3. **Prompts:** The system prompts if additional information is required to complete a command.

**Multiple options:** If multiple options are available for your command, the system displays a numbered list of options to choose from. Speak the appropriate line number, such as **LINE TWO**.

**Barging in:** To interrupt the prompt, press the VOICE RECOGNITION switch during the prompt and speak the desired command after the beep.

### NOTE

*Voice commands are universal rather than mode-specific. For example, a media command can be used while in tuner mode. The system will switch to media mode and carry out the command.*

## CANCELLING VOICE RECOGNITION

**Hand control:** Press and hold the VOICE RECOGNITION switch.

**Voice command:** At any time, say **CANCEL** to terminate the current session.

**No valid input:** If the system does not recognize a voice command, a response to a prompt, or if an extended period of

time elapses before a command is spoken, the session automatically cancels.

## TELEPROMPTER

See Figure 135. The teleprompter is shown when the VOICE RECOGNITION switch is pressed. The teleprompter screen shows commonly used commands, along with a line item to display more commands.

The CURSOR/SELECT switch can be used to select a command. Speaking or selecting **MORE COMMANDS** displays a list of all commands.



Figure 135. Teleprompter (Typical)

## COMMAND LIST

See Figure 136. If a command is not spoken or recognized while the teleprompter is displayed, the system shows a list of command categories. Speak one of the categories into the microphone, or use the CURSOR/SELECT switch to show all commands related to a selected category.

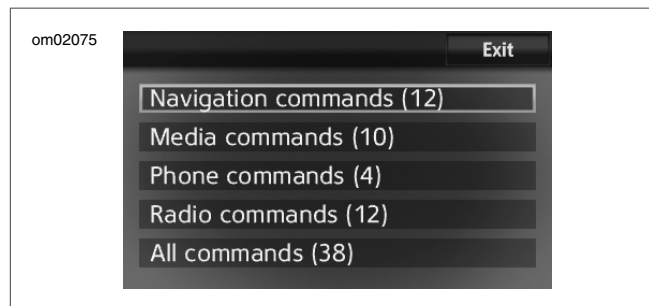

Figure 136. Command List (typical)



## PICK LIST

See Figure 137. Pick lists are presented in the following situations.

- More than one reasonable recognition of a word is available
- Multiple choices are available
- Navigation needs to refine a location

When presented with a pick list, speak the desired line item into the microphone such as **LINE THREE**.

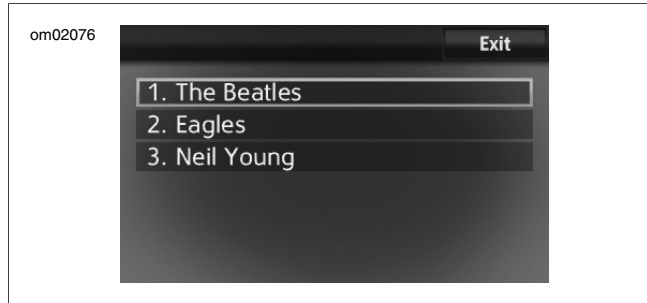

**Figure 137. Pick List Example**

## PROMPTER RESPONDS "PARDON?"

**Microphone:** Speak voice commands into the microphone of the headset. Proper placement of the microphone is critical to the effectiveness of voice commands.

**Speech:** Speak naturally into the headset microphone. Articulate each word in a voice command. Do not pause between words. The system cannot recognize rapid speech or a raised voice level.

**Numbers:** Pronounce numbers as individual numerals. Speak the number 88 as "eight, eight" rather than "eighty-eight". Speak zeros as "zero" or "oh". Pronounce decimal points in frequency numbers as "point".

## VOICE RECOGNITION COMMANDS

**Table 30. Voice Recognition: General Commands**

COMMAND	DESCRIPTION
ALL COMMANDS	List all available voice recognition commands.
CANCEL	Cancel voice recognition session.
LINE <NUMBER>	Select line number from list.
LIST	Show list of options.
YES	Acknowledge or continue.
NO	Decline or end.

**Table 31. Voice Recognition: Tuner Commands**

COMMAND	DESCRIPTION
A M	Set tuner to AM band.
F M	Set tuner to FM band.
WEATHER BAND	Set tuner to weather band.
MEDIUM WAVE	Set tuner to MW band.

**Table 31. Voice Recognition: Tuner Commands**

<b>COMMAND</b>	<b>DESCRIPTION</b>
LONG WAVE	Set tuner to LW band.
TUNE TO <FREQUENCY>	Tunes to a specified frequency. The radio will automatically change to the appropriate band for the selected frequency. <b>Example:</b> When saying TUNE TO NINETY-EIGHT POINT SEVEN, the tuner will change to the FM band and tune to 98.7 MHz.
SEEK UP/SEEK DOWN	Seeks next station up or down.
NEXT PRESET/PREVIOUS PRESET	Selects next/previous preset.
STATION <NAME>	Tunes to a selected station (European region only).

**Table 32. Voice Recognition: Media Commands**

<b>COMMAND</b>	<b>DESCRIPTION</b>
MEDIA	Enters media mode.
PLAY <ARTIST, ALBUM or SONG>	Plays songs from the selected artist.
ARTIST <NAME>	Plays songs from the selected artist.
ALBUM <NAME>	Plays the selected album.

**Table 32. Voice Recognition: Media Commands**

<b>COMMAND</b>	<b>DESCRIPTION</b>
PLAY ALL SONGS	Plays all songs on the media device.
GENRE <NAME or LIST ALL>	Plays songs from a selected genre or lists all available genres.
NEXT TRACK	Plays next track on media device.
PLAY PLAYLIST <NAME>	Plays a selected playlist.
PREVIOUS TRACK	Plays previous track on media device.
SONG <NAME>	Plays the selected song.
SEARCH FOR MUSIC	Search for a song or list all songs on a device.

**Table 33. Voice Recognition: Phone Commands**

<b>COMMAND</b>	<b>DESCRIPTION</b>
CALL <CONTACT NAME>	Begins a phone call to a phone book contact or locally saved contact. The system prompts if the contact has more than one phone number (home, mobile, work or other).
DIAL <PHONE NUMBER>	Dials a selected phone number.
REDIAL	Dials previous phone number.

**Table 34. Voice Recognition: SiriusXM Commands**

<b>COMMAND</b>	<b>DESCRIPTION</b>
X M	Plays SiriusXM radio.
CHANNEL <NUMBER or NAME>	Changes to selected channel. The system automatically changes to SiriusXM when channel commands are used.
CHANNEL UP	Changes to next channel up.
CHANNEL DOWN	Changes to next channel down.
CHANNEL SCAN	Scans through the SiriusXM channels.

**Table 35. Voice Recognition: Navigation Commands**

COMMAND	DESCRIPTION
DESTINATION <ADDRESS>	<p>Begins a route to the selected address. This "one-shot destination" command is not available in some regions. If not supported, the system will prompt for address elements (city, state and so on) through a series of steps.</p> <p><b>Example:</b> It is recommended to say the destination as one string, such as <b>DESTINATION 400 WEST CANAL STREET MILWAUKEE WISCONSIN.</b></p> <p><b>Note:</b> Complex street addresses with letters and numbers (such as "N23W2345 River Run Road") may not be recognized by the voice recognition system. If a destination is not recognized, enter the address using the navigation menu.</p>
FAVORITE <SAVED>	<p>Begins a route to a previously saved destination.</p>
FIND NEXT <POI>	<p>Provides a list of stores or brands that match the requested POI. Select an item from the pick list to begin navigation to the POI.</p> <p><b>Note:</b> POI types (such as <b>FIND NEXT GAS STATION</b>) and brand names (such as <b>FIND NEXT SHELL</b>) are read from the navigation database. Not all POI names are translated by Boom! Box software into recognizable command words. Voice recognition matching can be made more difficult when the names consist of multiple words or syllables. If a particular name does not produce recognizable results, try synonyms or other variations of a POI command.</p>
SHOW MAP	<p>Displays the navigation map.</p>
CANCEL ROUTE GUIDANCE	<p>Cancels the current route.</p>

**Table 35. Voice Recognition: Navigation Commands**

<b>COMMAND</b>	<b>DESCRIPTION</b>
REPEAT INSTRUCTIONS	Replays the navigation instructions for the next turn.
ENTER <COUNTRY, STATE, CITY, ZIP CODE, STREET, HOUSE NUMBER>	Begins entering destination information into the address screen. <b>Example:</b> When saying ENTER STATE, the prompter responds with "Say the State Name". After providing the state name, the system continues to prompt for the remaining address fields on the screen.

## NOTES



## VEHICLE INFORMATION

See Figure 138. Press the VEHICLE INFORMATION switch to display the following items on the radio screen. The vehicle information will display even if the radio is turned off.

**Air temperature:** Displays the current ambient air temperature measured by the air temperature sensor on the motorcycle.

**Engine oil pressure:** Displays the engine oil pressure. Engine oil pressure normally varies from 5 psi (34 kPa) at idle speed to 30-38 psi (207-262 kPa) at 2000 rpm when engine is at normal operating temperature of 230 °F (110 °C). If oil pressure is low, check the oil supply. If the oil pressure lamp is also on, stop the engine immediately and do not ride further. Refer to the vehicle owner's manual or see an authorized Harley-Davidson dealer for service as necessary.

### NOTICE

**If the oil pressure indicator lamp remains lit, always check the oil supply first. If the oil supply is normal and the lamp is still lit, stop the engine at once and do not ride further until the trouble is located and the necessary repairs are made. Failure to do so may result in engine damage. (00157a)**

**Engine Idle Temperature Management System (EITMS):** Displays the status of the Engine Idle Temperature Management System (EITMS). The status can be ACTIVE, ENABLED or DISABLED. When EITMS is active, the ambient temperature has exceeded a temperature threshold during idling, and the rear cylinder turns off to cool the engine. See the vehicle owner's manual for further description.



Figure 138. Vehicle Status Screen

*NOTES*

## AUDIO SYSTEM CARE

Use only Harley-Davidson recommended products and methods to keep the radio, speakers and other audio system components clean and in good condition. Do not use any abrasives, polishes or rubbing compounds to clean the screen or other components. Do not use any ammonia-based cleaners on the screen. Use of other products or methods may cause damage to components.

### Replaceable Screen Protector

Boom! Box 6.5GT radios have a replaceable screen protector. Keep the protector on the screen at all times. Damage to the screen due to use without the protector will not be covered under warranty. Remove and replace the protector if it becomes dull, scratched or worn.

### Cleaning the Radio

Spray a light amount of HARLEY GLOSS on a MICROFIBER DETAILING CLOTH. Be careful to gently remove any sedi-

ments without rubbing them into the screen. Apply circular motions from the center and outwards. Use a dry MICROFIBER DETAILING CLOTH to dry the screen. Repeat the process as necessary.

#### NOTE

*Do not use any screen enhancing chemicals or products. These can damage the screen surface.*

### Speaker Care

If a haze develops on speakers with a protective grille, use HARLEY SEAT, SADDLEBAG, AND TRIM CLEANER and a SOFTCLOTH or SOFT DETAILING PAD to clean. Do not apply wax or any other similar products on speaker grilles.

Do not use compressed or forced air on speakers.

Vehicles with saddlebag speakers are designed to prevent water intrusion and to allow water to drain during washing or riding in all weather. To remove any standing water from saddlebag speakers, open the saddlebags and gently shake any remaining water from the speakers.

## NOTES

## 2015 LIMITED RADIO WARRANTY

Harley-Davidson warrants that your Harley-Davidson radio will be free from factory defects in factory materials and workmanship, under normal use and service, for a period of twenty-four (24) months starting from the earlier of (a) the date of initial retail purchase of the motorcycle on which the radio is installed, or (b) the third anniversary of the last day of the model year of the motorcycle on which the radio is installed. Any unexpired portion of this limited warranty will be transferred to subsequent owner(s), upon the resale of the motorcycle during the limited warranty period. If the motorcycle was used as a demonstrator or company motorcycle, then the limited warranty period may have started and/or expired prior to the initial retail sale. See an authorized Harley-Davidson Dealer for details.

This limited warranty does not cover defects or damage due to abuse, misuse or improper installation, or any radio on a motorcycle which has been registered with Harley-Davidson as a collector's vehicle. Radios with a touchscreen have a replaceable protective film. Damage to the radio due to use without this screen protector is not covered under warranty. The screen protector itself is a serviceable wear part which can be purchased at an authorized Harley-Davidson dealer. Wear or subsequent damage to the screen protector is not covered under warranty. Also, the limited warranty does not cover syncing issues or an improper functioning radio caused by an incompatible phone or other media storage device (MP3, jump drive, etc.). See an authorized Harley-Davidson dealer

for details. Use of aftermarket parts may void all or parts of your limited warranty.

To obtain warranty service, return your motorcycle with sound system intact, at your expense, within the limited warranty period to an authorized Harley-Davidson dealer. Authorized Harley-Davidson dealers should be able to provide warranty service during normal business hours depending upon the workload of the authorized dealer's service department and the availability of necessary parts.

The remedy for breach of this warranty is expressly limited to the repair or replacement (**which may include a refurbished replacement radio**), without charge for parts and labor, of any part that proves to be defective, AND DOES NOT EXTEND TO LIABILITY FOR CONSEQUENTIAL DAMAGES, COSTS OR EXPENSES, INCLUDING LOSS OF TIME, INCONVENIENCE, COMMERCIAL LOSS, OR LOSS OF USE OF THE VEHICLE, RESULTING FROM ANY PART THAT PROVES TO BE DEFECTIVE.

THERE IS NO OTHER EXPRESS WARRANTY ON THE RADIO. ANY IMPLIED WARRANTY RELATING TO THIS RADIO, INCLUDING WARRANTIES OF MERCHANTABILITY OR FITNESS FOR A PARTICULAR PURPOSE, IS EXPRESSLY LIMITED TO THE DURATION OF THIS LIMITED WARRANTY.

TO THE FULLEST EXTENT ALLOWED BY LAW, HARLEY-DAVIDSON AND ITS AUTHORIZED DEALERS SHALL NOT BE LIABLE FOR LOSS OF TIME, INCONVENIENCE, LOSS

OF MOTORCYCLE USE, COMMERCIAL LOSS OR ANY OTHER INCIDENTAL OR CONSEQUENTIAL DAMAGES.

Some states do not allow the exclusion or limitation of incidental or consequential damages, so the above limitation or exclusion may not apply to you.

## **Other Rights**

This warranty gives you specific legal rights, and you may also have other rights which vary from state to state.

# AUSTRALIA/NEW ZEALAND 2015 LIMITED RADIO WARRANTY

## Your Consumer Rights

The benefits given to you under this H-D Radio Warranty are additional to, and do not detract from, other rights and remedies that you may have in respect of the radio or its installation under Australian and New Zealand laws, including consumer protection laws.

In Australia, our goods come with guarantees that cannot be excluded under the Australian Consumer Law. You are entitled to a replacement or refund for a major failure and compensation for any other reasonably foreseeable loss or damage. You are also entitled to have the goods repaired or replaced if the goods fail to be of acceptable quality and the failure does not amount to a major failure.

In New Zealand, our goods also come with guarantees that cannot be excluded under the New Zealand Consumer Guarantees Act.

## Warranty

This warranty is provided by Harley-Davidson Motor Company P.O. Box 653, Milwaukee, Wisconsin 53201, U.S.A, phone: +1 (414 343-4056) ("Harley-Davidson").

Harley-Davidson warrants that an authorised Harley-Davidson dealer will repair or replace your Harley-Davidson radio if it is

found to be defective in factory materials or workmanship, under normal use and service, during the warranty period set out below.

Such repair or replacement will be Harley-Davidson's sole obligation and your sole remedy under this H-D Radio Warranty, however you may have other rights under Australian and New Zealand laws, as described above.

**Note** that goods presented for repair may be replaced by refurbished goods of the same type rather than being repaired. Refurbished parts may be used to repair goods.

## Warranty Period

The warranty period is a period of twenty-four (24) months starting from the earlier of:

- (a) the date of delivery of the motorcycle on which the radio is installed by an authorised Harley-Davidson dealer to the first retail purchaser; or
- (b) the third anniversary of the last day of the model year of the motorcycle on which the radio is installed (if not sold to a retail purchaser before that date).

Any unexpired portion of this H-D Radio Warranty will be transferred to subsequent owners, upon the resale of the motorcycle during the limited warranty period. See the OWNER CONTACT INFORMATION section of this Owner's Manual for information regarding notification of ownership changes.

**Note:** If the motorcycle was used as a demonstrator or company motorcycle, then the warranty period may have started and/or expired prior to the initial retail sale. See an authorised Harley-Davidson dealer for details.

## Exclusions

This H-D Radio Warranty does not cover defects or damage due to abuse, misuse or improper installation, or any radio on a motorcycle which has been registered with Harley-Davidson as a collector's vehicle. Radios with a touchscreen have a replaceable protective film. Damage to the radio due to use without this screen protector is not covered under warranty. The screen protector itself is a serviceable wear part which can be purchased at an authorized Harley-Davidson dealer. Wear or subsequent damage to the screen protector is not

covered under warranty. Also, the limited warranty does not cover syncing issues or an improper functioning radio caused by an incompatible phone or other media storage device (MP3, jump drive, etc.). See an authorised Harley-Davidson dealer for details.

## Obtaining Warranty Service

To obtain warranty service, return your motorcycle with sound system intact, at your expense, within the warranty period to an authorised Harley-Davidson dealer.

Harley-Davidson's network of authorised dealers is large, and continues to expand. To find current contact information for your nearest authorised dealer, visit our website at [www.h-d.com.au](http://www.h-d.com.au).



## WHAT EVERY RESPONSIBLE CITIZENS BAND (CB) STATION OPERATOR SHOULD KNOW AS PREPARED BY THE FEDERAL COMMUNICATIONS COMMISSION, WASHINGTON, D.C.

### Subpart D-Citizens Band (CB) Radio Service General Provisions

#### Sec. 95.401 (CB Rule 1) What is the Citizens Band Radio Services?

The Citizens Band (CB) Radio Service is a private, two-way, short-distance voice communications service for personal or business activities of the general public. The CB Radio Service may also be used for voice paging.

#### Sec. 95.401 (CB Rule 2) How do I use these rules?

(a) You must comply with these rules (See CB Rule 21 Sec. 95.421, for the penalties for violations) when you operate a station in the CB Service from:

1. Within or over the territorial limits of places where radio services are regulated by the FCC (see CB Rule 5, Sec. 95.405);
2. Aboard any vessel or aircraft registered in the United States; or

3. Aboard any unregistered vessel or aircraft owned or operated by a United States citizen or company.

(b) Your CB station must comply with technical rules found in subpart E of part 95.

(c) Where the rules use the word "you", "you" means a person operating a CB station.

(d) Where the rules use the word "person," the rules are concerned with an individual, a corporation, a partnership, an association, a joint stock company, a trust, a state, territorial or local government unit, or other legal entity.

(e) Where the rules use the term "FCC", that means the Federal Communications Commission.

(f) Where the rules use the term "CB station", that means a radio station transmitting in the CB Radio Service.

#### Sec. 95.403 (CB Rule 3) Am I eligible to operate a CB station?

You are authorized to operate a CB station unless:

- (a) You are a foreign government, a representative of a foreign government, or a federal government agency; or
- (b) The FCC has issued a cease and desist order to you, and the order is still in effect.

#### Sec. 95.404 (CB Rule 4) Do I need a license?

You do not need an individual license to operate a CB station. You are authorized by this rule to operate your CB station in accordance with the rules in this subpart.

**Sec. 95.405 (CB Rule 5) Where may I operate my CB station?**

You are authorized to operate your CB station from:

(a) Within or over any area of the world where radio services are regulated by the FCC. Those areas are within the territorial limits of:

1. The fifty United States.
2. The District of Columbia. Caribbean Insular areas:
3. Commonwealth of Puerto Rico.
4. Navassa Island.
5. United States Virgin Islands (50 islets and cays).

Pacific Insular areas:

6. American Samoa (seven islands).
7. Baker Island.
8. Commonwealth of Northern Mariana Islands.
9. Guam Island.

10. Howland Island
11. Jarvis Island.
12. Johnston Island (Islets East, Johnston, North and Sand).
13. Kingman Reef.
14. Midway Island (Islets Eastern and Sand).
15. Palmyra Island (more than 50 islets).
16. Wake Island (Islets Peale, Wake and Wilkes).

(b) Any other area of the world, except within the territorial limits of areas where radio services are regulated by?An agency of the United States other than the FCC. (You are subject to its rules.)Any foreign government. (You are subject to its rules.)

(c) An aircraft or ship, with the permission of the captain, within or over any area of the world where radio services are regulated by the FCC or upon or over international waters. You must operate your CB station according to any applicable treaty to which the United States is a party.

(d) Anyone intending to operate a CB station on the islands of Puerto Rico, Desecheo, Mona, Vieques, and Culebra in a manner that could pose an interference threat to the Arecibo Observatory shall notify the Interference Office, Arecibo Observatory, Post Office Box 995, Arecibo, Puerto Rico 00613,

in writing or electronically, of the location of the unit. Operators may wish to consult interference guidelines, which will be provided by Cornell University. Operators who choose to transmit information electronically should e-mail to: prcz@naic.edu.

1. The notification to the Interference Office, Arecibo Observatory shall be made 45 days prior to commencing operation of the unit. The notification shall state the geographical coordinates of the unit.
2. After receipt of such notifications, the Commission will allow the Arecibo Observatory a period of 20 days for comments or objections. The operator will be required to make reasonable efforts in order to resolve or mitigate any potential interference problem with the Arecibo Observatory. If the Commission determines that an operator has satisfied its responsibility to make reasonable efforts to protect the Observatory from interference, the unit may be allowed to operate.

**Sec. 95.406 (CB Rule 6) Are there any special restrictions on the location of my CB station?**

(a) If your CB station is located on premises controlled by the Department of Defense you may be required to comply with additional regulations imposed by the commanding officer of the installation.

(b) If your CB station will be constructed on an environmentally sensitive site, or will be operated in such a manner as to raise environmental problems, under Sec. 1.1307 of this chapter, you must provide an environmental assessment, as set forth in Sec. 1.1311 of this chapter, and undergo the environmental review, Sec. 1.1312 of this chapter, before commencement of construction.

**How to Operate a CB Station**

**Sec. 95.407 (CB Rule 7) On what channels may I operate?**

(a) Your CB station may transmit only on the following channels (frequencies):

Channel.....	Frequency (megahertz - MHz)
1.....	26.965
2.....	26.975
3.....	26.985
4.....	27.005
5.....	27.015
6.....	27.025
7.....	27.035
8.....	27.055
9.....	*27.065
10.....	27.075
11.....	27.085
12.....	27.105
13.....	27.115
14.....	27.125
15.....	27.135
16.....	27.155
17.....	27.165
18.....	27.175
19.....	27.185
20.....	27.205
21.....	27.215
22.....	27.225
23.....	27.255
24.....	27.235



25.....	27.245	26.....	27.265
27.....	27.275	28.....	27.285
29.....	27.295	30.....	27.305
31.....	27.315	32.....	27.325
33.....	27.335	34.....	27.345
35.....	27.355	36.....	27.365
37.....	27.375	38.....	27.385
39.....	27.395	40.....	27.405

\*See paragraph (b) of this section

(b) Channel 9 may be used only for emergency communications or for traveler assistance.

(c) You must, at all times and on all channels, give priority to emergency communication messages concerning the immediate safety of life or the immediate protection of property.

(d) You may use any channel for emergency communications or for traveler assistance.

(e) You must share each channel with other users.

(f) The FCC will not assign any channel for the private or exclusive use of any particular CB station or group of stations.

(g) The FCC will not assign any channel for the private or exclusive use of CB stations transmitting single sideband or AM.

**Sec. 95.408 (CB Rule 8) How high may I put my antenna?**

(a) Antenna means the radiating system (for transmitting, receiving or both) and the structure holding it up (tower, pole or mast). It also means everything else attached to the radiating system and the structure.

(b) If your antenna is mounted on a hand-held portable unit, none of the following limitations apply.

(c) If your antenna is installed at a fixed location, it (whether receiving, transmitting or both) must comply with either one of the following:

1. The highest point must not be more than 6.10 meters (20 feet) higher than the highest point of the building or tree on which it is mounted; or
2. The highest point must not be more than 18.3 meters (60 feet) above the ground.

(d) If your CB station is located near an airport, and if you antenna structure is more than 6.1 meters (20 feet) high, you may have to obey additional restrictions. The highest point of your antenna must not exceed one meter above the airport elevation for every hundred meters of distance from the nearest point of the nearest airport runway. Differences in ground elevation between your antenna and the airport runway may complicate this formula. If your CB station is near an airport, you may contact the nearest FCC field office for a worksheet to help you figure the maximum allowable height of your

antenna. Consult part 17 of the FCC's Rules for more information. Warning: Installation and removal of CB station antennas near powerlines is dangerous. For your safety, follow the installation directions included with your antenna.

**Sec. 95.409 (CB Rule 9) What equipment may I use at my CB station?**

(a) You must use an FCC certificated CB transmitter at your CB station. You can identify an FCC certificated transmitter by the certification label placed on it by the manufacturer. You may examine a list of certificated equipment at any FCC Field Office or at FCC Headquarters. Use of a transmitter which is not FCC certificated voids your authority to operate the station.

(b) You must not make, or have made, any internal modification to a certificated CB transmitter. (See CB Rule 25, Sec. 95.425). Any internal modification to a certificated CB transmitter cancels the certification, and use of such a transmitter voids your authority to operate the station.

**Sec. 95.410 (CB Rule 10) How much power may I use?**

(a) Your CB station transmitter power output must not exceed the following values under any conditions: AM (A3)- 4 watts (carrier power) SSB- 12 watts (peak envelope power)

(b) If you need more information about the power rule, see the technical rules in subpart E of part 95.

(c) Use of a transmitter which has carrier or peak envelope power in excess of that authorized voids your authority to operate the station.

**Sec. 95.411 (CB Rule 11) May I use power amplifiers?**

(a) You may not attach the following items (power amplifiers) to your certificated CB transmitter in any way:

1. External radio frequency (RF) power amplifiers (sometimes called linears or linear amplifiers); or
2. Any other devices which, when used with a radio transmitter as a signal source, are capable of amplifying the signal.

(b) There are no exceptions to this rule and use of a power amplifier voids your authority to operate the station.

(c) The FCC will presume you have used a linear or other external RF power amplifier if:

1. It is in your possession or on your premises; and
2. There is other evidence that you have operated your CB station with more power than allowed by CB Rule 10, Sec. 95.410.

(d) Paragraph (c) of this section does not apply if you hold a license in another radio service which allows you to operate an external RF power amplifier.

**Sec. 95.412 (CB Rule 12) What communications may be transmitted?**

(a) You may use your CB station to transmit two-way plain language communications. Two-way plain language communications are communications without codes or coded messages. Operating signals such as "ten codes" are not considered codes or coded messages. You may transmit two-way plain language communications only to other CB stations, to units of your own CB station or to authorized government stations on CB frequencies about--

1. Your personal or business activities or those of members of your immediate family living in your household;
2. Emergencies (see CB Rule 18, Sec. 95.418);
3. Traveler assistance (see CB Rule 18, Sec. 95.418); or
4. Civil defense activities in connection with official tests or drills conducted by, or actual emergencies announced by, the civil defense agency with authority over the area in which your station is located.

(b) You may use your CB station to transmit a tone signal only when the signal is used to make contact or to continue communications. (Examples of circuits using these signals are tone operated squelch and selective calling circuits.) If the signal is an audible tone, it must last no longer than 15 seconds at one

time. If the signal is a subaudible tone, it may be transmitted continuously only as long as you are talking.

(c) You may use your CB station to transmit oneway communications (messages which are not intended to establish communications between two or more particular CB stations) only for emergency communications, traveler assistance, brief tests (radio checks) or voice paging.

**Sec. 95.413 (CB Rule 13) What communications are prohibited?**

(a) You must not use a CB station:

1. In connection with any activity which is against federal, state or local law;
2. To transmit obscene, indecent or profane words, language or meaning;
3. To interfere intentionally with the communications of another CB station;
4. To transmit one-way communications, except for emergency communications, traveler assistance, brief tests (radio checks), or voice paging;
5. To advertise or solicit the sale of any goods or services;
6. To transmit music, whistling, sound effects or any material to amuse or entertain;

7. To transmit any sound effect solely to attract attention;
8. To transmit the word "MAYDAY" or any other international distress signal, except when your station is located in a ship, aircraft or other vehicle which is threatened by grave and imminent danger and you are requesting immediate assistance;
9. To communicate with, or attempt to communicate with, any CB station more than 250 kilometers (155.3 miles) away;
10. To advertise a political candidate or political campaign; (you may use your CB radio for the business or organizational aspects of a campaign, if you follow all other applicable rules);
11. To communicate with stations in other countries, except General Radio Service stations in Canada; or
12. To transmit a false or deceptive communication.

(b) You must not use a CB station to transmit communications for live or delayed rebroadcast on a radio or television broadcast station. You may use your CB station to gather news items or to prepare programs.

**Sec. 95.414 (CB Rule 14) May I be paid to use my CB station?**

(a) You may not accept direct or indirect payment for transmitting with a CB station.

(b) You may use a CB station to help you provide a service, and be paid for that service, as long as you are paid only for the service and not for the actual use of the CB station.

**Sec. 95.415 (CB Rule 15) Who is responsible for communications I make?**

You are responsible for all communications which are made by you from a CB station.

**Sec 95.416 (CB Rule 16) Do I have to limit the length of my communications?**

(a) You must limit your CB communications to the minimum practical time.

(b) If you are communicating with another CB station or stations, you, and the stations communicating with you, must limit each of your conversations to no more than five continuous minutes.

(c) At the end of your conversation, you, and the stations communicating with you, must not transmit again for at least one minute.

**Sec. 95.417 (CB Rule 17) Do I identify my CB communications?**

- (a) You need not identify your CB communications.
- (b) [You are encouraged to identify your CB communications by any of the following means:
1. Previously assigned CB call sign;
  2. K prefix followed by operator initials and residence zip code;
  3. Name; or
  4. Organizational description including name and any applicable operator unit number.]

(c) [You are encouraged to use your "handle" only in conjunction with the methods of identification listed in paragraph (b) of this section.]

**Sec. 95.418 (CB Rule 18) How do I use my CB station in an emergency to assist a traveler?>**

- (a) You must at all times and on all channels, give priority to emergency communications.
- (b) When you are directly participating in emergency communications, you do not have to comply with the rule about length of transmissions (CB Rule 16, Sec. 95.416). You must obey all other rules.

(c) You may use your CB station for communications necessary to assist a traveler to reach a destination or to receive necessary services. When you are using your CB station to assist a traveler, you do not have to obey the rule about length of transmissions (CB Rule 16, Sec. 95.416). You must obey all other rules.

(d) You may use your CB station to transmit oneway communications concerning highway conditions to assist travelers.

**Sec. 95.419 (CB Rule 19) May I operate my CB station transmitter by remote control?**

(a) You may not operate a CB station transmitter by radio remote control.

(b) You may operate a CB transmitter by wireline remote control if you obtain specific approval in writing from the FCC. To obtain FCC approval, you must show why you need to operate your station by wireline remote control. If you receive FCC approval, you must keep the approval as part of your station records. See CB Rule 27, Sec. 95.427.

(c) Remote control means operation of a CB transmitter from any place other than the location of the CB transmitter. Direct mechanical control or direct electrical control by wire from some point on the same premises, craft or vehicle as the CB transmitter is not considered remote control.



**Sec. 95.420 (CB Rule 20) May I connect my CB station transmitter to a telephone?**

(a) You may connect your CB station transmitter to a telephone if you comply with all of the following:

1. You or someone else must be present at your CB station and must-
    - (i) Manually make the connection (the connection must not be made by remote control);
    - (ii) Supervise the operation of the transmitter during the connection;
    - (iii) Listen to each communication during the connection; and
    - (iv) Stop all communications if there are operations in violation of these rules.
  2. Each communication during the telephone connection must comply with all of these rules.
  3. You must obey any restriction that the telephone company places on the connection of a CB transmitter to a telephone.
- (b) The CB transmitter you connect to a telephone must not be shared with any other CB station.

(c) If you connect your CB transmitter to a telephone, you must use a phone patch device with has been registered with the FCC.

**OTHER THINGS YOU NEED TO KNOW**

**Sec. 95.421 (CB Rule 21) What are the penalties for violating these rules?**

- (a) If the FCC finds that you have willfully or repeatedly violated the Communications Act or the FCC Rules, you may have to pay as much as \$10,000 for each violation, up to a total of \$75,000. (See section 503(b) of the Communications Act.)
- (b) If the FCC finds that you have violated any section of the Communications Act or the FCC Rules, you may be ordered to stop whatever action caused the violation. (See section 312(b) of the Communications Act.)
- (c) If a Federal court finds that you have willfully and knowingly violated any FCC Rule, you may be fined up to \$500 for each day you committed the violation. (See section 502 of the Communications Act.)
- (d) If a Federal court finds that you have willfully and knowingly violated any provision of the Communications Act, you may be fined up to \$10,000 or you may be imprisoned for one year, or both. (See section 501 of the Communications Act.)

**Sec. 95.422 (CB Rule 22) How do I answer correspondence from the FCC?**

(a) If it appears to the FCC that you have violated the Communications Act or these rules, the FCC may send you a discrepancy notice.

(b) Within the time period stated in the notice, you must answer with:

1. A complete written statement about the apparent discrepancy;
2. A complete written statement about any action you have taken to correct the apparent violation and to prevent it from happening again; and
3. The name of the person operating at the time of the apparent violation.

(c) If the FCC sends you a letter asking you questions about your CB radio station or its operation, you must answer each of the questions with a complete written statement within the time period stated in the letter.

(d) You must not shorten your answer by references to other communications or notices.>\

(e) You must send your answer to the FCC office which sent you the notice.

(f) You must keep a copy of your answer in your station records. (See CB Rule 27, Sec. 95.427.)

**Sec. 95.423 (CB Rule 23) What must I do if the FCC tells me that my CB station is causing interference?**

(a) If the FCC tells you that your CB station is causing interference for technical reasons you must follow all instructions in the official FCC notice. (This notice may require you to have technical adjustments made to your equipment.)

(b) You must comply with any restricted hours of CB station operation which may be included in the official notice.

**Sec. 95.424 (CB Rule 24) How do I have my CB station transmitter serviced?**

(a) You may adjust an antenna to your CB transmitter and you may make radio checks. (A radio check means a one way transmission for a short time in order to test the transmitter.)

(b) You are responsible for the proper operation of the station at all times and are expected to provide for observations, servicing and maintenance as often as may be necessary to ensure proper operation. You must have all internal repairs or internal adjustments to your CB transmitter made in accordance with the Technical Regulations (see subpart E). The internal repairs or internal adjustments should be performed by or under the immediate supervision and responsibility of a person certified as technically qualified to perform transmitter maintenance

and repair duties in the private land mobile services and fixed services by an organization or committee representative of users in those services.

(c) Except as provided in paragraph (d) of this section, each internal repair and each internal adjustment of a CB transmitter in which signals are transmitted must be made using a nonradiating ("dummy") antenna.

(d) Brief test signals (signals not longer than one minute during any five minute period) using a radiating antenna may be transmitted in order to:

1. Adjust an antenna to a transmitter;
2. Detect or measure radiation of energy other than the intended signal; or
3. Tune a receiver to your CB transmitter.

**Sec. 95.425 (CB Rule 25) May I make any changes to my CB station transmitter?**

(a) You must not make or have any one else make any internal modification to your CB transmitter.

(b) Internal modification does not include:

1. Repair or servicing of a CB station transmitter (see CB Rule 24, Sec. 95.424); or

2. Changing plug-in modules which were certificated as part of your CB transmitter.

3. You must not operate a CB transmitter which has been modified by anyone in any way, including modification to operate on unauthorized frequencies or with illegal power. (See CB Rules 9 and 11, Secs. 95.409 and 95.411.)

**Sec. 95.426 (CB Rule 26) Do I have to make my CB station available for inspection?**

(a) If an authorized FCC representative requests to inspect your CB station, you must make your CB station and records available for inspection.

(b) A CB station includes all of the radio equipment you use.

**Sec. 95.427 (CB Rule 27) What are my station records?**

Your station records include the following documents, as applicable.

(a) A copy of each response to an FCC violation notice or an FCC letter. (See CB Rule 22, Sec. 95.422.)

(b) Each written permission received from the FCC. (See CB Rule 19, Sec. 95.419.)

**Sec. 95.428 (CB Rule 28) How do I contact the FCC?**

(a) FCC National Call Center at 1-888-225-5322.

(b) FCC World Wide Web homepage: <http://www.fcc.gov>.

Source: 48 FR 24894, June 3, 1983, unless otherwise noted.

(c) In writing, to FCC, Attention: CB, 1270 Fairfield Road,  
Gettysburg, PA 17325-7245.

## **H-D U.S.A., LLC TRADEMARK INFORMATION**

Bar & Shield, Boom!, Cross Bones, Cruise Drive, CVO, Digital Tech, Digital Technician, Digital Technician II, Dyna, Electra Glide, Evolution, Fat Bob, Fat Boy, Forty-Eight, Glaze, Gloss, H-D, H-Dnet.com, Harley, Harley-Davidson, HD, Heritage Softail, Iron 883, Low Rider, Night Rod, Nightster, Night Train, Profile, Reflex, Revolution, Road Glide, Road King, Road Tech, Rocker, Screamin' Eagle, Seventy-Two, Softail, Sportster, Street Glide, Street Rod, Sun Ray, Sunwash, Super Glide, SuperLow, Switchback, SYN3, TechLink, TechLink II, Tour-Pak, Tri Glide, Twin Cam 88, Twin Cam 88B, Twin Cam 96, Twin Cam 96B, Twin Cam 103, Twin Cam 103B, Twin Cam 110, Twin Cam 110B, Twin-Cooled, Ultra Classic, V-Rod,

VRSC and Harley-Davidson Genuine Motor Parts and Genuine Motor Accessories are among the trademarks of H-D U.S.A., LLC.

## **PRODUCT REGISTERED MARKS**

Apple, Alcantara S.p.A., Allen, Amp Multilock, Bluetooth, Brembo, Delphi, Deutsch, Dunlop, Dynojet, Fluke, G.E. Versilube, Garmin, Gunk, Hydroseal, Hylomar, iPhone, iPod, Kevlar, Lexan, Loctite, Lubriplate, Keps, K&N, Magnaflux, Marson Thread-Setter Tool Kit, MAXI fuse, Molex, Michelin, MPZ, Multilock, nano, NGK, Novus, Packard, Pirelli, Permatex, Philips, PJ1, Pozidriv, Robinair, S100, Sems, SiriusXM, Snap-on, Teflon, Threadlocker, Torca, Torco, TORX, Tufoil, Tyco, Ultratorch, Velcro, X-Acto, XM Satellite Radio, and zumo are among the trademarks of their respective owners.

*NOTES*

<b>A</b>	
A2DP/AVRCP Profile (AV/Music).....	93
Accessory Mode.....	33
Air Temperature.....	193
Alternate Frequency Switching (AF).....	See RBDS/RDS
Amplifier.....	32
Antenna	
CB.....	32
Hidden.....	32
Satellite.....	32
Tuner.....	32
Audio Functions	
Left Hand Controls.....	21
Rear (Passenger) Controls.....	25
Right Hand Controls.....	22
Audio Settings (Bass/Treble).....	54
Automatic Volume Control (AVC).....	See Speed Volume

<b>B</b>	
Background Color.....	51
Bass.....	See Audio Settings
Bluetooth	
Apps and Players.....	80
Connecting a Device.....	90
Connecting Media Device.....	80
Deleting a Device.....	92
Description.....	33
Enabling.....	89

Pairing a Device.....	89
Phone Profiles.....	93
Reconnecting.....	91
Brightness	
Buttons.....	50
Screen.....	49
Buttons	
Multiselect.....	37
Scroll Controls.....	37

<b>C</b>	
Care and Cleaning	
Audio System.....	195
Replaceable Screen Protector.....	195
Speakers.....	195
Categories (Cat)	
FM (RBDS, North American).....	72
FM (RDS, Other Regions).....	72
Program Types (PTYs).....	70
Selecting.....	71
CB	
Adding Optional Module.....	117
Channels (Popular or Reserved).....	114
Conflicting Transmissions.....	112
Emergency Operation.....	112
FCC Regulations.....	201
Noise.....	114
Passenger Operation.....	116
Presets.....	114

Range.....	117	Favorite (FAV) Switch.....	18
Receiving.....	113	HOME/VOLUME/PREVIOUS/NEXT Switch.....	22
Squelch.....	114	HOME Switch.....	18
Transmission.....	113	MODE/UP/DN Switch.....	24
Tuning Channels.....	114	NAVIGATION Switch.....	19
Turning Off.....	112	POWER/MUTE Switch.....	18
Turning On.....	111	Push-To-Talk (PTT) Switch.....	23
Volume.....	116	Rear (Passenger).....	57
Charging a Phone.....	93	Rear (Passenger) Controls.....	24
Checkbox.....	36	Soft Keys.....	19
Classic Mode.....	57	Squelch (SQ+/SQ-) Switch.....	23
Clock		Touchscreen.....	20
12 or 24-Hour Mode.....	52	VEHICLE INFORMATION Switch.....	23
Daylight Savings Time (DST).....	52	VOICE RECOGNITION Switch.....	23
GPS Synchronized.....	52	CURSOR/SELECT Switch.....	23
RDS Synchronized.....	52		
Time Zones.....	52	<b>D</b>	
User Time.....	52	Day/Night Colors Mode.....	50
Colors		Daylight Savings Time (DST).....	See Clock
Automatic.....	50	Disconnecting the Vehicle Battery.....	34
Background.....	51		
Day.....	51	<b>E</b>	
Night.....	51	Emergency CB Operation.....	4
Compass.....	149	Emergency Phone Number.....	4
Controls		Enabling Rear Controls.....	See Rear (Passenger) Controls
CURSOR/SELECT Switch.....	23	Engine Idle Temperature Management System.....	193
		English Units of Measurement.....	51



<b>F</b>	
Factory Restore.....	63
Fade.....	54
Favorite (FAV) Switch.....	18
Favorites	
Description.....	65
Favorite (FAV) Switch.....	18
Selecting.....	65
Setting.....	65
FCC CB Rules. . . See Regulatory Compliance, FCC CB Rules	
Features	
Models.....	5
Feedback.....	56

<b>G</b>	
Global Presets.....	58
GPX Files	
Exporting.....	164
Importing.....	165

<b>H</b>	
Hand Controls	
Left.....	20
Right.....	20
Hands-Free Calling Profile (HFP).....	93

Headset	
Connectors.....	25
Selection.....	53
HFP+PBAP+AV Profile.....	93
Home Screen.....	35

<b>I</b>	
Intercom	
Adjusting Microphone Sensitivity (VOX).....	121
Adjusting Volume.....	121
Description.....	119
Operating (PTT Switch).....	122
Operating (Voice Activation).....	122
Speed Volume.....	121
Turning On/Off.....	120

<b>K</b>	
Keyboard	
Full.....	39
Large.....	39
Operation.....	39
Selection.....	53

<b>L</b>	
Language	
Selection.....	49
Settings.....	49

## M

### Map

Changing Display. . . . .	147
Displaying. . . . .	144
Scrolling (Hand Controls). . . . .	151
Scrolling (Touchscreen). . . . .	151
Selecting Destination. . . . .	156
Selecting POI. . . . .	152

### Map Database

Database Update. . . . .	179
FLTRUSE and FLHTKSE Updates. . . . .	179
Intercontinental Restoration. . . . .	181
Intercontinental Replacement. . . . .	180
Verifying Database Version. . . . .	178

### Media

Apps and Players. . . . .	80
Connecting Device (Bluetooth). . . . .	80
Connecting Device (USB). . . . .	79
Devices. . . . .	78
Device Support. . . . .	79
Finding File. . . . .	84
Finding File (Artist/Album/Genre). . . . .	85
Finding File (Audio Book). . . . .	87
Finding File (General). . . . .	83
Finding File (Playlist). . . . .	85
Finding File (Podcast). . . . .	86

Finding File (Song Title). . . . .	85
Finding File (Video/TV Show). . . . .	87
Finding File (Voice Recognition). . . . .	87
Pause/Rewind/Fast Forward. . . . .	81
Play from Track List. . . . .	82
Play Previous/Next File. . . . .	81
Play Random File (Shuffle). . . . .	82
Presets. . . . .	83
Repeat File. . . . .	82
Save Ring Tone. . . . .	88
Saving File as Favorite. . . . .	88
Scanning Files. . . . .	81
Screen. . . . .	77
Selecting Device. . . . .	80
Media Compartment (USB Port). . . . .	28
Message Access Profile (MAP). . . . .	93
Metric Units of Measurement. . . . .	51
Microphone	
Connectors. . . . .	25
Positioning (Full Face Helmets). . . . .	27
Positioning (Open Face or Half Helmets). . . . .	27
Models. . . . .	5
Multiselect Button. . . . .	37
Muting Audio. . . . .	18

## N

National Oceanic and Atmospheric Administration (NOAA). . . . .	73
---	----

National Weather Radio (NWR).....	73	Icons, POI.....	153
Navigation		Icons, Roads and Transportation.....	146
Avoiding a Road.....	170	Icons, Terrain.....	147
Calling a Destination (Route Active).....	173	Importing a Route.....	165
Calling a Destination (Route Not Active).....	173	Lane Guidance.....	170
Canceling a Route (Using Menus).....	160	Low Fuel Alert.....	174
Canceling a Route (Voice Command).....	160	Maneuvers (Turn-By-Turn Instructions).....	168
Changing Data Fields.....	148	Map Scrolling (Hand Controls).....	151
Changing Map Display.....	147	Map Scrolling (Touchscreen).....	151
Checking Database Version.....	60	Navigating a Trail.....	164
Compass.....	149	Option Menu.....	148
Creating a Trip (Using Map).....	161	Prompts (Adjusting Volume Using Menus).....	178
Creating a Trip (Using Menus).....	161	Prompts (Adjusting Volume with Hand Controls)....	178
Database Version Verification.....	178	Prompts (Speaker/Headset Selection).....	178
Data Field Options.....	148	Prompts (Turning On/Off).....	177
Deleting a Trail.....	164	Prompt Settings.....	56
Description.....	143	Record a Trail (Options Menu).....	163
Displaying a Maneuver (Zoom).....	169	Record a Trail (Trails Menu).....	163
Displaying Map.....	144	Rename a Trail.....	164
Editing a Trip (Adding Waypoints).....	162	Replacing the Intercontinental Database.....	180
Editing a Trip (Reordering Waypoints).....	162	Rerouting.....	176
Editing a Trip (Skipping Waypoints).....	162	Restoring an Avoided Road.....	170
Exporting a Route.....	164	Restoring an Intercontinental Database.....	181
GPS Information.....	174	Ride Planner.....	166
Icons, Avoidances.....	149	Round Trip.....	161
Icons, Map Components.....	146	Route Preferences and Avoidances.....	148

Route To Destination (Address).....	154
Route To Destination (Coordinates).....	159
Route To Destination (Dealership).....	158
Route To Destination (Emergency).....	158
Route To Destination (Home).....	155
Route To Destination (Map Scroll Tool).....	156
Route To Destination (Phone Book).....	156
Route To Destination (POI).....	157
Route To Destination (Recent).....	155
Route To Destination (Saved).....	156
Route To Destination (Voice Command).....	160
Route To Destination (XMSirius Fuel Prices Feature).....	160
Safety.....	3
Saving a Destination.....	171
Saving Current Location.....	172
Selecting POI On Map.....	152
Showing a Planned Route.....	172
Simulating a Route.....	172
Traffic.....	175
Traffic Event List (RDS Traffic).....	177
Traffic Notification Settings.....	176
Trails.....	163
Trips.....	160
Trip Summary.....	173
Turning Traffic On/Off.....	176
Updating Database.....	179

NAVIGATION Switch.....	19
------------------------	----

## O

Oil Pressure.....	193
Options	
Models.....	5

## P

Part Number.....	60
Passenger Controls.....	See Rear (Passenger) Controls
Pausing Media.....	18
Phone	
Adding New Ring Tone.....	107
Adjusting Call Volume.....	99
Bluetooth and USB Connection.....	93
Bluetooth Profiles.....	93
Call History.....	103
Call Screen.....	94
Call Screen Functions.....	96
Changing the Emergency Phone Number.....	108
Charging.....	93
Compatibility.....	93
Delete Phone Contact.....	103
Enabling Text Message Notification.....	104
Ending a Call.....	99
Making a Call (Calling a Contact with Voice Recognition).....	98

Making a Call (Dialing) . . . . .	96	Viewing/Playing a Text Message. . . . .	106
Making a Call (Dialing with Voice Recognition) . . . . .	98	Voice Mail. . . . .	100
Making a Call (Emergency Phone Number) . . . . .	98	Phonebook Access Profile (PBAP) . . . . .	93
Making a Call (Navigation POI) . . . . .	97	Popup Screens. . . . .	42
Making a Call (Phone Book Contact) . . . . .	97	POWER/MUTE Switch. . . . .	18
Making a Call (SiriusXM Gas Station) . . . . .	97	Pre-Ride Checklist. . . . .	3
Multiple Calls. . . . .	100	Presets	
Muting Call Audio. . . . .	99	Global. . . . .	58
Phone Book. . . . .	100	Global Page Settings. . . . .	59
Phone Menu. . . . .	93	PREVIOUS/NEXT Switch. . . . .	22
Receiving a Call (Accepting/Ignoring) . . . . .	98	Privacy Reset. . . . .	63
Receiving a Call (Radio Turned Off) . . . . .	99	Program Types (PTYs) . . . . .	70
Refresh Phone Book. . . . .	101	Prompts	
Resuming Calls After Vehicle Shutdown. . . . .	107	Settings. . . . .	56
Routing Call Audio. . . . .	99	Push-To-Talk (PTT) Switch. . . . .	23
Saved Contacts and Phone Numbers. . . . .	102		
Saving a Dialed Phone Number. . . . .	102	<b>R</b>	
Saving a Phone Book Contact. . . . .	102	Radio	
Saving Phone Number from Current Call. . . . .	102	Care and Cleaning. . . . .	195
Saving Ring Tone (Media) . . . . .	88	Radio Broadcast Data System (RBDS) . . . . .	75
Selecting Ring Tone. . . . .	106	Radio Data System (RDS) . . . . .	75
Setting Up Contacts. . . . .	101	RBDS/RDS	
Show Contact Details. . . . .	101	Tuner. . . . .	75
Text Message Auto-Reply. . . . .	105	Rear (Passenger) Controls	
Text Messaging. . . . .	103	Enabling Rear Controls. . . . .	24
Transferring a Call Back to the Phone. . . . .	108	MODE/UP/DN Switch. . . . .	24
		Push-To-Talk (PTT)/Volume (VOL) Switch. . . . .	24

Regionalization (REG).....	See RBDS/RDS
Regulatory Compliance	
FCC CB Rules.....	201
Replaceable Screen Protector.....	See Care and Cleaning
Reset	
Factory Restore.....	63
Privacy.....	63
Ride Planner	
Exporting Route.....	166
Rider Planner.....	165

## S

Safety	
Emergency CB Operation.....	4
Emergency Phone Number.....	4
Features.....	1
Navigation.....	3
Pre-Ride Checklist.....	3
Scan	
Media Files.....	81
SiriusXM Channels.....	128
Stations.....	70
Screen	
Home.....	35
Lockout.....	42
Menu Bar.....	36
Popup.....	42

Screen Brightness.....	49
Scroll Controls.....	37
Seek	
Station.....	69
Serial Number.....	60
Settings	
Audio (Bass/Treble).....	54
Background Color.....	51
Button Brightness.....	50
Classic Mode.....	57
Clock.....	52
English/Metric Units.....	51
Fade.....	54
Feedback (Prompts).....	56
Global Presets.....	58
Keyboard.....	53
Language.....	49
Rear (Passenger) Controls.....	57
Screen Brightness.....	49
Setup Menu.....	47
Speaker/Headset Selection.....	53
Speed Volume.....	55
Setup	
Day/Night Colors Mode.....	50
Menu.....	47
Menu.....	48

System. . . . .	47	Subscribing. . . . .	124
Short Message Service (SMS). . . . .	See Text Messaging	Tag Alert. . . . .	129
SiriusXM		Tagging Artist or Song. . . . .	128
Adding a Game Zone Favorite. . . . .	130	Traffic. . . . .	136
Categories. . . . .	129	Traffic Icons. . . . .	136
Check Subscription Status (Radio). . . . .	123	Traffic Message List. . . . .	137
Description. . . . .	123	Traffic Notification Popups. . . . .	136
Displaying 5 Day Forecast. . . . .	134	Traffic Reroute. . . . .	136
Displaying Current Weather. . . . .	132	Trial Description. . . . .	123
Displaying Daily Forecast (3 and 6 hour). . . . .	133	Turning Traffic On. . . . .	136
Display Last Weather Update. . . . .	141	Viewing Fuel Prices. . . . .	135
Enabling Sports Alerts. . . . .	130	Viewing Tagged List. . . . .	129
Fuel Prices. . . . .	134	Weather Map. . . . .	138
Game Zone. . . . .	130	Weather Map Radar and Fronts. . . . .	139
Listening To Radio. . . . .	125	Weather Map Scrolling. . . . .	139
Optional Accessory. . . . .	123	Smart Speller. . . . .	41
Presets. . . . .	126	SMS. . . . .	See Text Messaging
Removing a Game Zone Favorite. . . . .	132	Soft Keys. . . . .	19
Responding To Game Zone Alert. . . . .	131	Software	
Scanning Channels. . . . .	128	Update. . . . .	61
Selecting Channel (Channel List). . . . .	127	Version Number. . . . .	60
Selecting Channel (Direct Tune). . . . .	127	Speaker/Headset Selection. . . . .	53
Selecting Channel (Hand Controls). . . . .	127	Speakers	
Selecting Channel (Voice Recognition). . . . .	128	Care and Cleaning. . . . .	195
Selecting Fuel Type. . . . .	134	Fairing. . . . .	31
Setting Game or Score Notification. . . . .	131	Fairing Lower. . . . .	31

Saddlebag.....	31
Selection.....	53
Tour-Pak.....	32
Specifications	
Models.....	5
Speed Volume.....	55
Squelch (SQ+/SQ-) Switch.....	23
Station List.....	72
Status Bar.....	42
Icons.....	45
Supplier Part Number.....	60
System Information	
Navigation Database.....	60
Part Number.....	60
Serial Number.....	60
Software Version.....	60

## T

Text Messaging	
Enabling Text Message Service.....	104
Text-To-Speech (TTS).....	103
Time.....	See Clock
Time Zones.....	See Clock
Total Harmonic Distortion (THD).....	32
Touchscreen.....	20
Trademarks	
Harley-Davidson.....	213

Referenced Products.....	213
Traffic	
RDS Event List.....	177
SiriusXM.....	136
Traffic Program/Traffic Announcement (TP/TA).....	76
Trails.....	See Navigation, Trails
Treble.....	See Audio Settings
Trips.....	See Navigation, Trips
Tuner	
Categories (Cat).....	70
Description.....	67
Presets.....	70
RBDS/RDS.....	75
Scanning Stations.....	70
Seeking a Station (Hand Control Switch).....	69
Seeking a Station (Voice Recognition).....	69
Selecting a Band (HOME Hand Control, Classic Mode).....	68
Selecting a Band (Menu Buttons).....	68
Selecting a Band (Voice Recognition).....	68
Selecting Categories.....	71
Station List.....	72
Tune/Seek/Preset Settings.....	68
Tuning a Station (Hand Control Switch).....	69
Tuning a Station (Voice Recognition).....	69
Weather Alert.....	74



Weather Band.....	73
Turning Motorcycle On/Off.....	33

## U

### Units of Measurement

English.....	52
Metric.....	52
USB Devices.....	See Media
USB Drive	
Format.....	78
Hub.....	29
Media Compartment.....	29
Port.....	28

## V

Vehicle Information.....	See Vehicle Status
Vehicle Information Switch.....	23
Vehicle Status	
Air Temp.....	193
EITMS.....	193
Oil Pressure.....	193
Voice Commands	
Activating.....	183
Cancelling.....	183
Command List.....	184
Commands.....	186
General.....	183

Media.....	187
Phone.....	188
Pick List.....	185
Prompts.....	185
SiriusXM.....	189
Teleprompter.....	184
Tuner.....	186
VOICE RECOGNITION Switch.....	23
Volume	
Adjustment.....	41
Controls.....	22
Feedback (Prompts).....	56
Speed.....	55
Volume Controls	
Passenger.....	41
Rider.....	41
Volume Switch.....	22
VOX (Microphone Sensitivity).....	121

## W

Warranty	
Radio.....	197
Weather Alert.....	74
Weather Band	
Channel Presets.....	74
Frequencies.....	74
NOAA.....	73

NWR.....	73
Weatherradio Canada.....	74
Weather Map	
Information.....	140
Radar and Fronts.....	139
Scrolling.....	139
Weather Front Information.....	140
Weatherradio Canada.....	See Weather Band



