

A black and white profile photograph of a man wearing a dark hooded jacket and a baseball cap. The man is looking downwards and to the left. The background is out of focus, showing some indistinct shapes and light. A semi-transparent blue rectangular box is overlaid on the lower right portion of the image, containing white text.

**AARON GWIN**  
A FOUR-TIME WORLD CUP  
OVERALL CHAMPION

YT | MOB







TRP WAS FOUNDED ON THE IDEA OF BUILDING THE HIGHEST QUALITY BRAKING SYSTEMS AVAILABLE IN THE BICYCLE INDUSTRY. TRP BRAKES ARE DESIGNED FOR SUPERIOR LEVELS OF PERFORMANCE AND DURABILITY ACHIEVED THROUGH THE USE OF ADVANCED PRODUCTION TECHNIQUES, ACCURATE PROCESSING AND METICULOUS QUALITY CONTROL. BY USING EXOTIC MATERIALS SUCH AS CARBON FIBER, TITANIUM AND T6 ALUMINUM, TRP BRAKES SET A NEW INDUSTRY STANDARD FOR LIGHTWEIGHT AND PRECISE CONTROL. TRP BRAKES ARE EXTENSIVELY TESTED FOR RELIABILITY AND SAFETY ON AND OFF-ROAD, AND IN THE LABORATORY - BY A COMPANY WITH MORE THAN 20 YEARS EXPERIENCE DESIGNING AND MANUFACTURING BICYCLE BRAKE SYSTEMS.

MOUNTAIN	5
CX / ROAD DISC	17
ROAD	31
AERO	41
PARTS/ACCESSORIES	47





SLATE T4



**MOUNTAIN**  
BRAKES

- Four Piston Forged Caliper
- Detent Reach Adjust
- 16mm Hybrid Pistons
- New Organic Pads
- Aaron Gwin Designed Lever
- Titanium Hardware
- I-Spec & Matchmaker Compatible
- 320g - Front

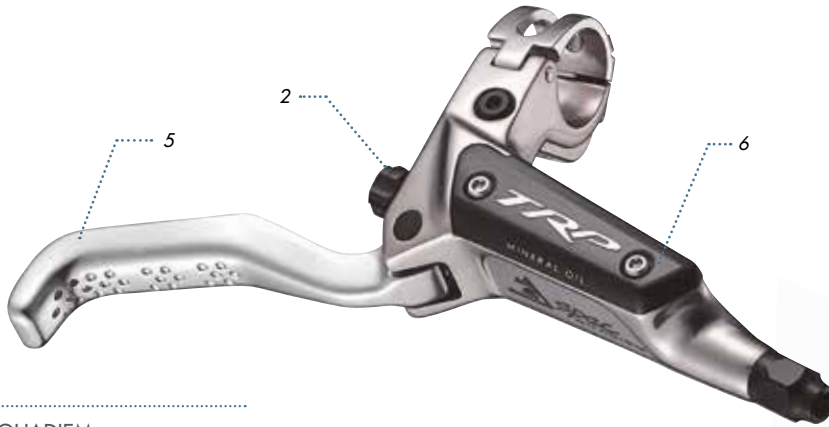

GSPEC QUADIEM

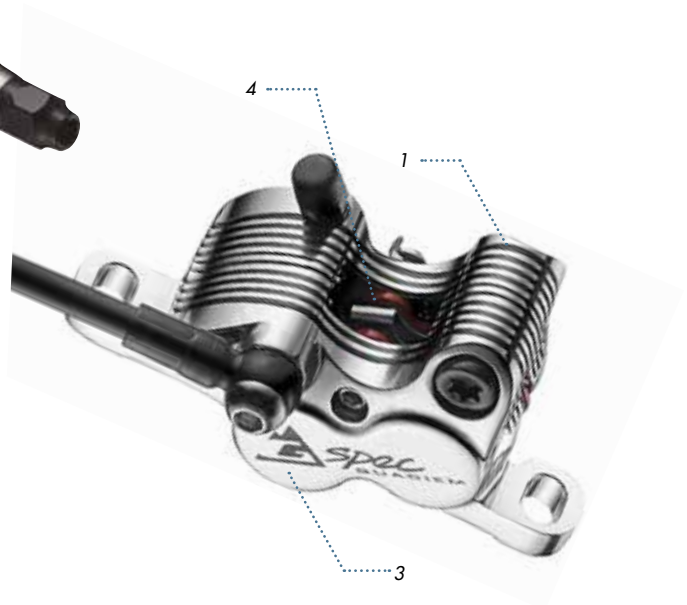

**QUADIEM**  
**Gspec**

Our best brake improved and redesigned with the input from Aaron Gwin and his team at YT Mob - improved power, cooling fins, hybrid pistons, detent reach adjust and metallic sintered pads. The lever was designed based on Aaron's specifications and has already been a part of his 2016 World Cup season wins.



ORGANIC PADS



TR-29



TR-33

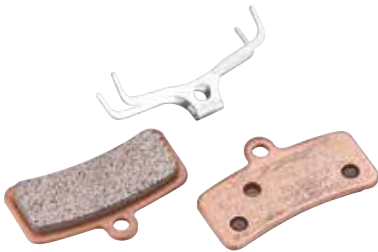

METALLIC PADS



TR-13



TR-25

FEATURES	OPTIONS	MODEL NUMBER
1 Four Piston Forged Caliper	11mm dia Quick Connect	HD-M840
2 Detent Reach Adjust	TR-29 Standard Rotor	
3 16mm Hybrid Pistons	TR-13 Two Piece Rotor	
4 New Sintered Metallic Pads Compatible	TR-33 Two Piece Rotor	
5 Aaron Gwin Designed Forged Lever	TR-25 Centerlock Rotor	
6 I-Spec & Matchmaker Compatible	Organic Pads	
	Metallic Pads	

- Four Piston Forged Caliper
- Detent Reach Adjust
- 16mm Caliper Pistons
- Split Hinged Handlebar Clamp
- Banjo Hose Fitting
- Aaron Gwin Designed Lever
- I-Spec & Matchmaker Compatible
- 325g - Front

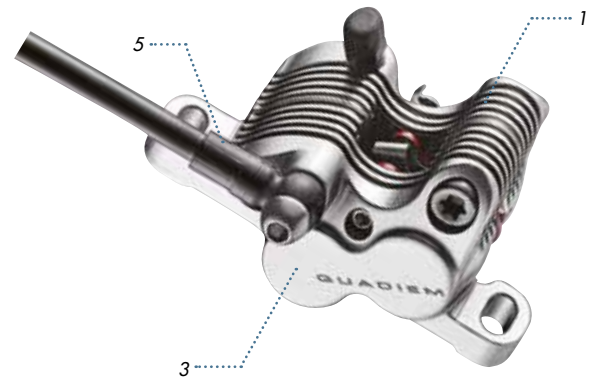
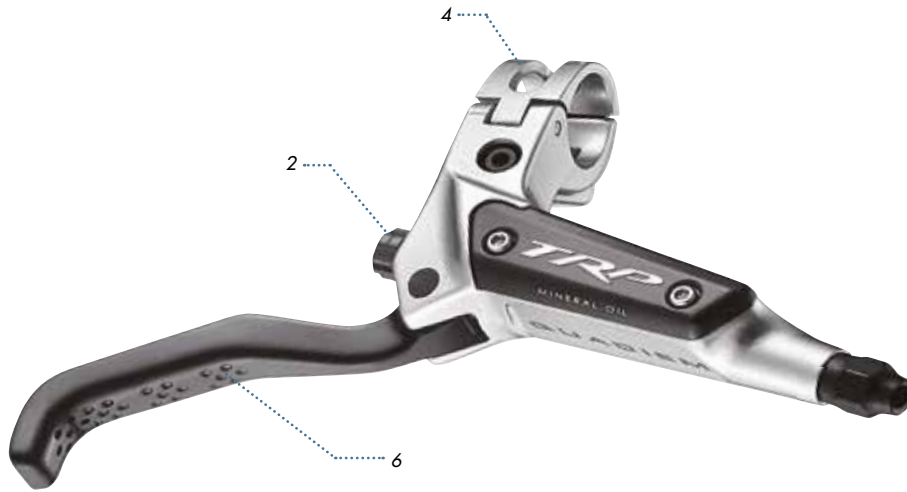

# QUADIEM

Our most powerful 4-piston brake was raced on the World Cup circuit by Aaron Gwin and his team. Includes the Aaron Gwin designed lever and the CNC cooling finned caliper. Not only proven on the race circuit, but just as worthy for eMtn bikes, plus-sized trail bikes - anywhere extra stopping power is needed.



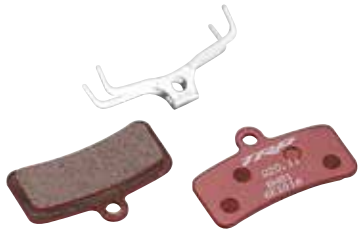

ORGANIC PADS



TR-29



TR-33

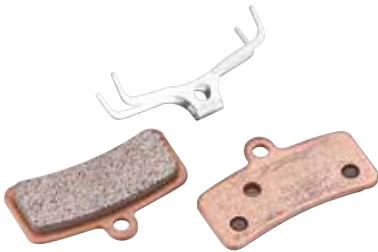

METALLIC PADS



TR-13



TR-25

FEATURES	OPTIONS	MODEL NUMBER
1 Four Piston Forged Caliper	11mm dia Quick Connect	Available in Canyon Silver
2 Detent Reach Adjust	TR-29 Standard Rotor	
3 16mm Caliper Pistons	TR-13 Two Piece Rotor	
4 Split Hinged Handlebar Clamp	TR-33 Two Piece Rotor	
5 Banjo Fitting for Optimal Hose Angle	TR-25 Centerlock Rotor	
6 Aaron Gwin Designed Forged Lever	Organic Pads	
7 I-Spec & Matchmaker Compatible	Metallic Pads	

- Four Piston Forged Caliper
- Lightweight Hybrid Pistons
- Detent Reach Adjust
- Aaron Gwin Designed Lever
- Split Hinged Clamp
- Banjo Hose Fitting
- Stainless Steel Hardware
- I-Spec & Matchmaker Compatible
- 290g

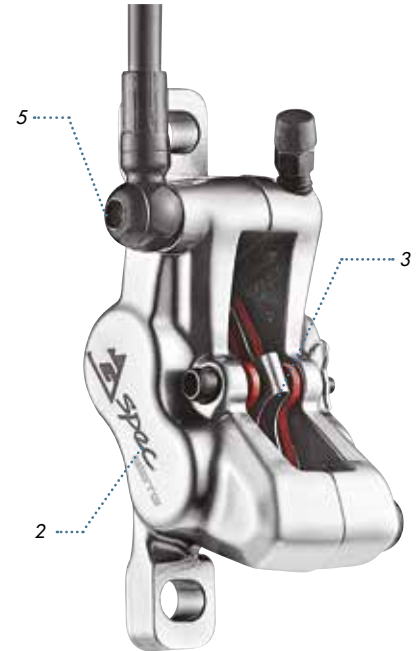

GSPEC SLATE



Leveraging our relationship with Aaron Gwin, our proven Slate design is now more powerful with the GSpec lever, lighter with the hybrid pistons complete stainless hardware. Class-leading design that works great for the added rotating mass of plus-sized mountain bikes yet light enough for any XC application.

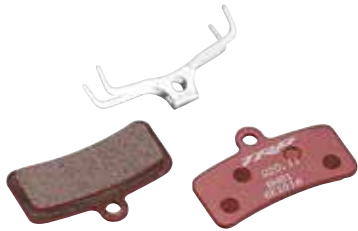

ORGANIC PADS



TR-29



TR-33



METALLIC PADS



TR-13



TR-25

FEATURES	OPTIONS	MODEL NUMBER
1 Four Piston Forged Caliper	11mm Quick Connect	Available in Canyon Silver
2 Lightweight Hybrid Pistons	TR-29 Standard Rotor	HD-M820
3 Aaron Gwin Designed Lever	TR-13 Two Piece Rotor	
4 Split Hinged Handlebar Clamp	TR-33 Two Piece Rotor	
5 Banjo Fitting for Optimal Hose Angle	TR-25 Centerlock Rotor	
6 Stainless Steel Hardware	Organic Pads	
7 I-Spec & Matchmaker Compatible	Metallic Pads	

Four Piston Forged Caliper  
16mm and 14mm Pistons  
Top Loading Pads Reach Adjust  
Split Hinged Clamp  
Banjo Hose Fitting  
Dimpled Lever Blade  
I-Spec & Matchmaker Compatible  
290g Front



## **SLATE T4**

A lightweight, four-piston mountain bike hydraulic disc brake system with top-loading pads, I-Spec and Matchmaker compatible split-hinged handlebar clamp and a banjo fitting on the caliper for optimal hose angle adjustments.



ORGANIC PADS



TR-29



TR-33



TR-13



TR-25

FEATURES	OPTIONS	MODEL NUMBER
1 Four Piston Forged Caliper	11mm Quick Connect	Available in Black or Canyon Silver
2 16mm and 14mm Caliper Pistons	TR-29 Standard Rotor	
3 Top Loading Pads	TR-13 Two Piece Rotor	
4 Split Hinged Handlebar Clamp	TR-33 Two Piece Rotor	
5 Banjo Fitting for Optimal Hose Angle	TR-25 Centerlock Rotor	
6 Dimpled Lever Blade	Organic Pads	
7 I-Spec & Matchmaker Compatible		



SPYKE



ML800

- Dual Piston Actuation
- Independent Pad Adjustments
- Integrated Barrel Adj. on Caliper
- Dust Cover and Boot
- Integrated Barrel Adj. on Lever
- Aluminum Lever Blade
- 78g Lever, 170g Caliper

# SPYKE ML800

Mechanical disc brake for linear pull levers with dual piston actuation for even rotor contact and improved power and modulation. Calipers have independent pad and cable barrel adjuster for easy tuning and feature a snow/mud cover and cable boot. ML800 lever is lightweight aluminum with an integrated barrel adjuster.



CABLE & HOUSING KIT



TR-13



TR-33



TR-29



TR-25

FEATURES	OPTIONS	MODEL NUMBER
1. Dual Piston Actuation	11mm Quick Connect	Available in Black
2. Independent Pad Adjustments	TR-29 Standard Rotor	ML800 - Lever
3. Top Loading Pads	TR-13 Two Piece Rotor	HD-M600 - Spyke Caliper
	TR-33 Two Piece Rotor	
	TR-25 Centerlock Rotor	
	Organic Pads	







**ROAD CX**  
*DISC BRAKES*

- 12mm or 15mm Thru Axle
- Internal Hose Routing
- Tapered Steerer Tube
- 40mm Tire Clearance
- Optional Fender Mounts
- 160mm Post Mount
- 455g, (15mm TA)

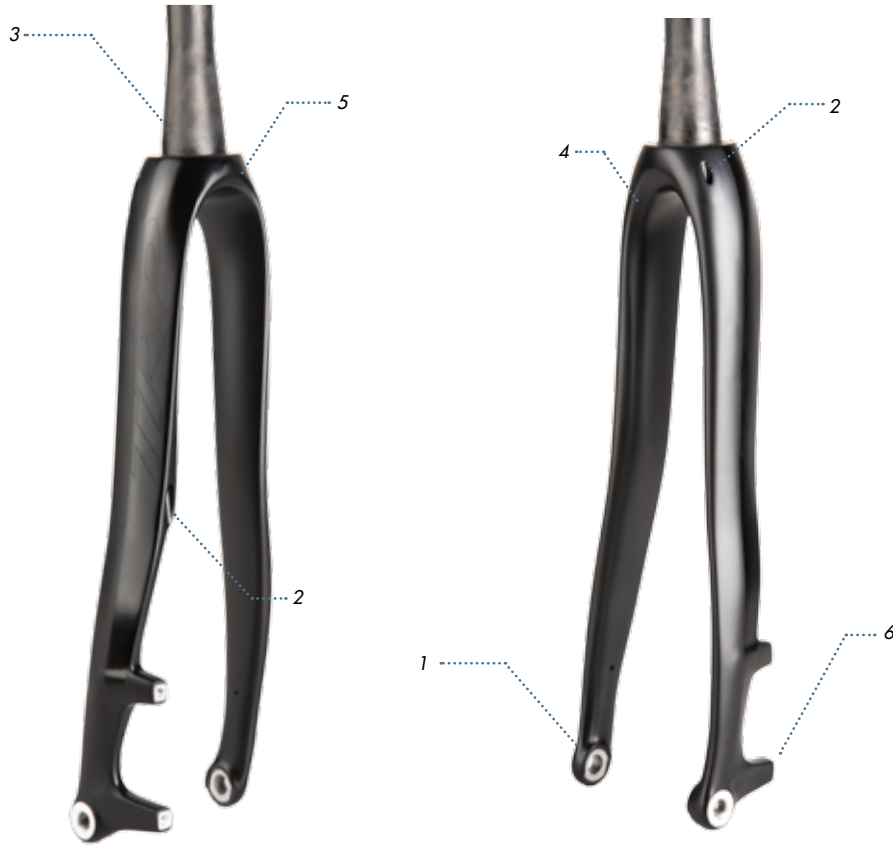

CX CARBON FORK

# FORK

Carbon fiber thru-axle cyclocross fork with optimized internal cable routing, 1.5" tapered steerer tube and clearance for 40mm tires.



*SPEEDAXLES*



*FENDER ADAPTORS*



*COMPRESSION PLUG*

FEATURES	OPTIONS	MODEL NUMBER
1 12mm or 15mm Thru Axle	Speedaxle	Available in Matte UD Finish or unpainted
2 Internal Hose Routing	Fender Adaptors	15mm Thru Axle
3 Tapered Steerer Tube	DT Threaded Axle	15mm Thru Axle with Fender Mounts
4 40mm Tire Clearance		12mm Thru Axle
5 Optional Fender Mounts		12mm Thru Axle with Fender Mounts
6 160mm Post Mount		

- Integrated Master Cylinder
- Drilled Lever Blade
- Forged One Piece Caliper
- Heat-Isolating Hybrid Pistons
- Top Loading Pads
- Flat Mount Caliper Optional
- 352g per wheel

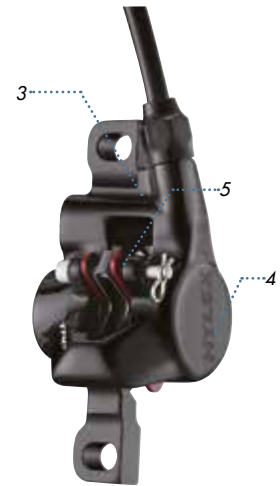
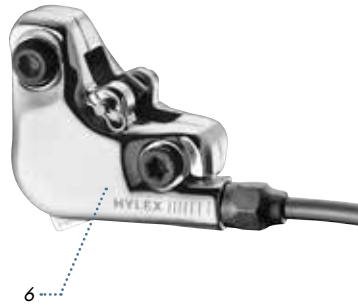

# HYLEX RS

Full hydraulic disc brake system for drop bars with an integrated master cylinder located in low-profile and ergonomically shaped lever body with a drilled lever blade. Calipers are a lightweight and responsive one piece forged unit housing heat-isolating hybrid pistons.



DI2 KIT

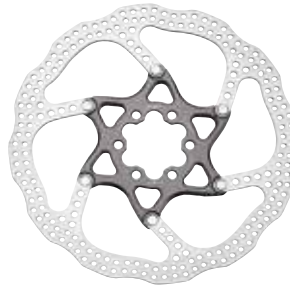

TR-13



TR-33



TR-29



TR-25

FEATURES	OPTIONS	MODEL NUMBER
1 Integrated Master Cylinder	DI2 Adaptor kit	S Black Lever w/ Black Caliper and Black Hoods
2 Drilled Lever Blade	Hylex replacement hoods	RS Silver Lever w/ Silver Caliper and Gum Hoods
3 Forged One Piece Caliper	TR-33 Two Piece Rotor	Rotors Sold Separately
4 Heat-Isolating Hybrid Pistons	TR-13 Two Piece Rotor	Post Mount or Flat Mount
5 Top Loading Pads	TR-29 One Piece Rotor	11mm Quick Connect Coupler
6 Flat Mount Caliper Optional	TR-25 Centerlock Rotor	

- Open Hydraulic System
- Integrated Master Cylinder
- Heat Isolating Hybrid Pistons
- Mechanical Actuation
- Flat Mount Caliper Optional
- 250g, Post Mount
- 224g, Flat Mount



HY-ROAD POST MOUNT



HY-ROAD FLAT MOUNT

# HY/RD FLATMOUNT HY/RD POSTMOUNT

Mechanical interface, open hydraulic disc brake system that is compatible with all mechanical road and CX levers. Features heat-isolating hybrid pistons that self-adjust to compensate for pad wear. HY/RD C is OEM version with matte black finish.



CABLE & HOUSING KIT

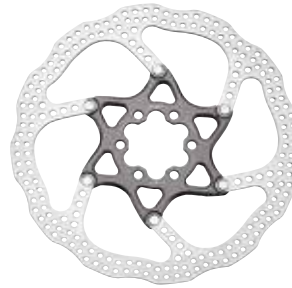

TR-13



TR-33



TR-29



TR-25

FEATURES	OPTIONS	MODEL NUMBER
1 Open Hydraulic System	TR-33 Two Piece Rotor	Available in Black
2 Integrated Master Cylinder	TR-29 One Piece Rotor	Rotor Sold Separately
3 Heat Isolating Hybrid Pistons	TR-25 Centerlock Rotor	Post Mount or Flat Mount
4 Mechanical Actuation	TR-13 Two Piece Rotor	
5 Flat Mount Caliper Optional		

HD-C705 - Hy-Road Post Mount  
 HD-C710 - Hy-Road Flat Mount

- Dual Piston Actuation
- Independent Pad Adjustments
- Integrated Cable Barrel Adjuster
- Dust Cover and Boot Now Included
- SLC Version: Carbon Fiber Arm
- 146g Spyre SLC Post Mount
- 154g Spyre SLC Flat Mount



SPYRE SLC POST MOUNT

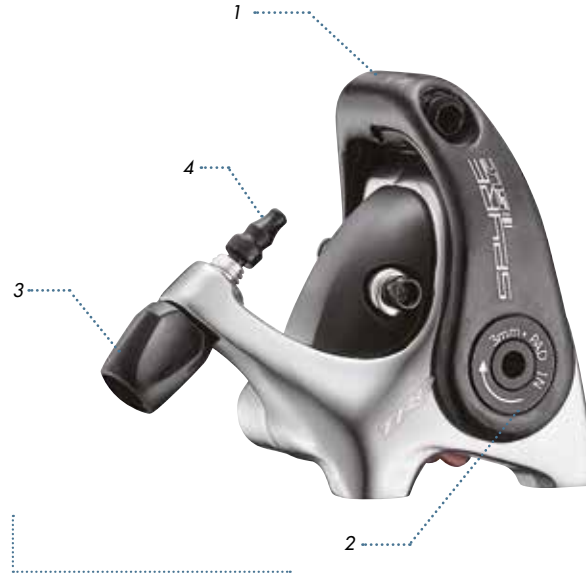

SPYRE SLC FLAT MOUNT

# SPYRE SLC FLATMOUNT SPYRE SLC POSTMOUNT

Mechanical disc brake for road levers with dual piston actuation for even rotor contact and improved power and modulation. Calipers have independent pad adjustments as well as a cable barrel adjuster for easy tuning. SLC version features carbon fiber actuation arm.





CABLE & HOUSING KIT



TR-13



TR-33



TR-29



TR-25

FEATURES	OPTIONS	MODEL NUMBER
1 Dual Piston Actuation	DiscConnect Cable and Housing Kit	High Polish Grey with Carbon Arm
2 Independent Pad Adjustments		
3 Integrated Cable Barrel Adjuster	TR-33 Two Piece Rotor	Rotor Sold Separately
4 Dust Cover and Boot Now Included	TR-13 Two Piece Rotor	Post Mount or Flat Mount
5 SLC Version Features Carbon Fiber Arm	TR-29 One Piece Rotor	
	TR-25 Centerlock Rotor	

- Dual Piston Actuation
- Independent Pad Adjustments
- Integrated Cable Barrel Adjuster
- Dust Cover and Boot Now Included
- SLC Version: Carbon Fiber Arm
- 154g Spyre Post Mount
- 159g Spyre Flat Mount



SPYRE POST MOUNT



SPYRE FLAT MOUNT

# SPYRE PLATMOUNT SPYRE POSTMOUNT

Mechanical disc brake for road levers with dual piston actuation for even rotor contact and improved power and modulation. Calipers have independent pad adjustments as well as a cable barrel adjuster for easy tuning. SLC version features carbon fiber actuation arm.



CABLE & HOUSING KIT

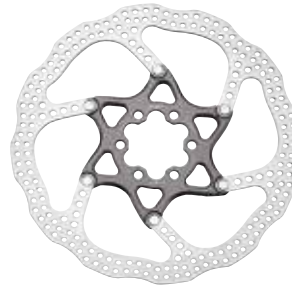

TR-13



TR-33



TR-29



TR-25

FEATURES	OPTIONS	MODEL NUMBER
1 Dual Piston Actuation	DiscConnect Cable and Housing Kit	Polish Black with Silver Arm
2 Independent Pad Adjustments	TR-33 Two Piece Rotor	Rotor Sold Separately
3 Integrated Cable Barrel Adjuster	TR-13 Two Piece Rotor	Post Mount or Flat Mount
4 Dust Cover and Boot Now Included	TR-29 One Piece Rotor	
	TR-25 Centerlock Rotor	

Compatible with all drop bar  
Levers  
84mm arm length  
Stainless steel hardware  
138g weight per wheel



CX8.4-BLACK



CX8.4-RED

# CX8.4



Linear pull cyclocross v-brake with forged and CNC machined brake arms which hold adjustable-angle cartridge pad holders and have independent spring tension adjustments. compatible with all drop bar brake levers.

UD Carbon Lever  
RL951 - 31.8mm Lever Clamp  
RL956 - 26mm Lever Clamp  
Weight:39g per lever



RL95 UD BLACK

## RL95 SERIES



Carbon composite top-mount brake lever with split-hinged clamp and cable barrel adjuster for easy installation and adjustment.



A close-up, high-contrast photograph of a motorcycle's front fork and brake assembly. The image is dominated by dark, metallic components, with a prominent red overlay on the right side. The text "ROAD BRAKES" is overlaid in white, bold, sans-serif font on the red area. The background is black, making the metallic parts stand out. The lighting highlights the textures and shapes of the metal, including the fork tubes, the brake caliper, and the brake disc. The overall aesthetic is technical and modern.

**ROAD  
BRAKES**

- Forged Alloy Arms
- Cam Style Quick Release
- Stainless Steel Hardware
- Inplace M Adjustable Cartridge Pad Holders



R980



# R980



Dual pivot road brake caliper with forged and CNC machined brake arms. Features a cam-style quick release, stainless hardware, inplace road adjustable-angle cartridge pad holders.



CNC Alloy Brake Arms  
Cam Style Quick Release  
Inplace CNC Cartridge Pad Holders  
Brake Centering Adjustment  
Direct Mount Compatible



T980



# T980



Direct mount mechanical rim brake designed to be mounted on the fork or seatstays and feature CNC alloy brake arms, inplace road adjustable pad holders, cam-style quick release and plenty of clearance for modern rim widths and tires up to 28mm.

- Forged Alloy Brake Arms
- Independent Arm Adjustments
- Inplace CNC Cartridge Pad Holders
- Center-Pull Cable Routing
- Aerodynamic Front Cover
- Direct Mount Compatible
- T860: 232g
- T861: 213g



T860



T861

# T860 T861



Direct mount mechanical rim brake designed to be mounted on the fork. Features aerodynamic shaping, shroud cover, CNC alloy brake arms, inplace road adjustable pad holders and plenty of clearance for modern rim widths and tires up to 28mm.

Forged Aluminum Brake Arms  
Independent Pad Adjustments  
Side or Center Pull Cable Routing  
Options  
Inplace Road CNC Cartridge Pad  
Holders  
Independent Spring Adjustment  
T850: 180g  
T851: 176g



T850



T851

# T850 T851

Direct mount mechanical rim brake designed to be mounted underneath the bottom bracket. Features wide clearance for crank arm mounted power meters, center-pull or side-pull cable routing, CNC alloy brake arms, inplace road adjustable pad holders and plenty of clearance for modern rim widths and tires up to 28mm.

- Forged Alloy Arms
- Cam Style Quick Release
- Stainless Steel Hardware
- Inplace M Adjustable Cartridge Pad Holders
- 160g per Wheel



R879



# R879



Dual pivot road brake caliper with forged and CNC machined brake arms. Features a cam-style quick release, stainless hardware, inplace road adjustable-angle cartridge pad holders.

Aerodynamic Arm Design  
CNC Inplace Adj. Pad Holders  
Front/Rear Cable Routing Options  
Independent Spring Adjustment  
Hidden Cable End  
Fits 28mm Tire  
139g per Wheel



TTV ROAD TR-02

**TTV-ROAD**



Super low-profile aerodynamic linear pull road brake that hides behind fork, seat stays or under bottom bracket. Features CNC inplace adjustable pad holders and either standard CNC cable noodle for easy routing or aero CNC cable noodle for optimum crank clearance.



RG957



- Forged Alloy Arms
- Cam Style Quick Release
- Stainless Steel Hardware
- 47-57mm Long Reach
- Inplace Road Adjustable Cartridge
- Pad Holders
- 167g per Wheel

# RG957



Dual pivot long-reach road caliper brake with cam-style quick release, stainless steel hardware, forged aluminum arms and CNC inplace road adjustable-angle cartridge pad holders.

Ergonomic Lever Profile  
Spring Loaded, Push-Button QR  
Grippy, Co-Molded Rubber Hoods  
272g per Pair - Carbon  
280g per Pair - SR  
290g per Pair - Alloy



RRL UD



RRL SR

## RRL SERIES

Ultra-light non-integrated brake lever for drop bars with an ergonomic lever profile, spring-loaded push-button quick release and replaceable grippy co-molded rubber hoods.

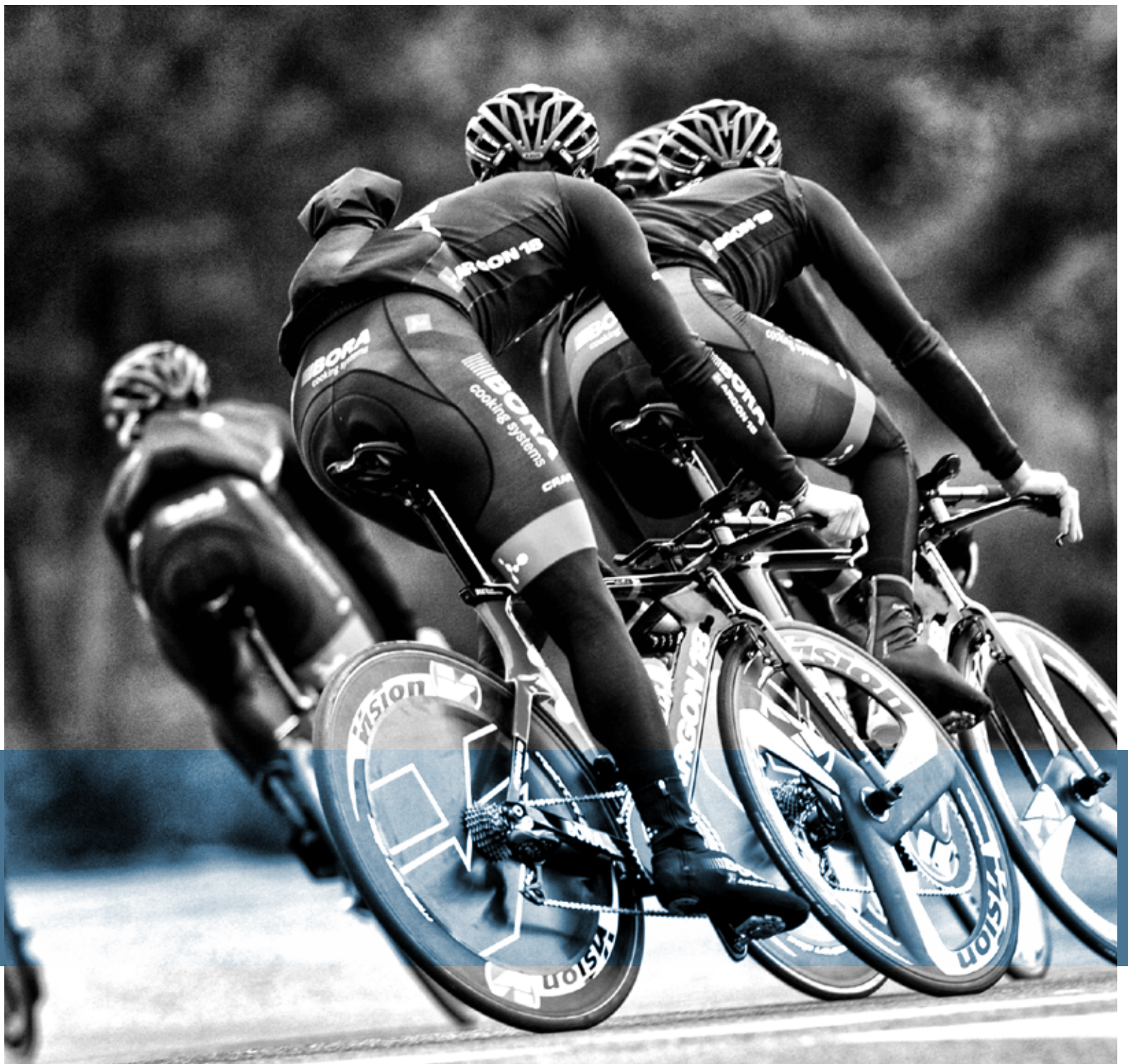





**AERO**  
BRAKES

- Carbon Fiber Lever Blade
- Forged Aluminum Lever Body
- Blip or Di2 Shift Inserts
- Replaceable Grip
- Forged Flat Mount Caliper
- 390g, Front



TT DISC LEVER



TT DISC FLAT MOUNT

# TT DISC



A fully hydraulic, flat mount option for TT bikes on the leading edge of aerodynamic design. Our modular grip system features inserts specific for SRAM Blip Shifters or Shimano's Di2 shift module, (SW-R600.)



BLIP AND DI2 KIT



TR-13



TR-33



TR-29



TR-25

FEATURES	OPTIONS	MODEL NUMBER
1 Carbon Fiber Lever Blade	Saddle Grip Colors	UD Carbon Lever Blade
2 Forged Aluminum Lever Body	Di2 Inserts	11mm Quick Connect Coupler
3 Blip or Di2 Shift Inserts	Blips Inserts	
4 Replaceable Grip	TR-29 One Piece Rotor	
5 Forged Flat Mount Caliper	TR-13 Two Piece Rotor	
	TR-33 Two Piece Rotor	
	TR-25 Centerlock Rotor	

- Carbon Composite Lever Blade
- Internal Cable Adjustment
- Ergonomic Lever Shape
- Spring-Loaded Quick Release
- Compatible with V-brakes and Direct Mount Calipers
- 162g per Set



TTLVR

**TTLVR**



Ergonomic carbon fiber TT/Tri brake lever with internal cable adjustment and spring-loaded quick release.

Carbon Fiber Lever Blade  
Aluminum Lever Body  
Ergonomic Lever Shape  
150g per Set



RL970

# RL970



Aerodynamic carbon fiber TT/Tri brake lever.



UCI MOUNTAIN BIKE WORLD CUP LOURDES FRANCE  
PRESENTED BY SHIMANO  
**1**  
CROSSLAND MTB

e\*thirteen

VITAL MTR  
complete tool set

FOX

CROSSLAND

CROSSLAND

CROSSLAND

CROSSLAND



**PARTS &  
ACCESSORIES**

## PARTS&ACCESSORIES



TR-25

- Available in:  
140 / 160 / 180 / 203 mm
- Centerlock
- Two Piece Design with Aluminum Center
- 139g (160mm)



TR-29

- Available in:  
140 / 160 / 180 / 203 mm
- 6-Bolt
- 116g (160mm)



TR-33

- Available in:  
140 / 160 / 180 / 203 mm
- 6-Bolt
- Two Piece Design with Aluminum Center
- Weight: 135g

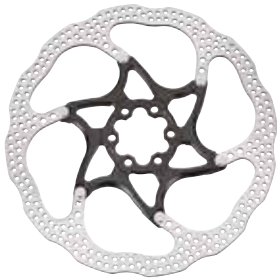

TR-13

- Available in:  
140 / 160 / 180 / 203 mm
- 6-Bolt
- Two Piece Design with Aluminum Center
- Weight: 126g(160mm)



TI ROTOR BOLTS

- Available in Pack of 6 Bolts



ROTOR SPACERS

- Available in:  
- 0.5mm Width  
- 1mm Width





FF1- F140



FF2- F160



FR1- R140



FR2- R160



F5



F6

FLAT MOUNT TO POST MOUNT

FLAT MOUNT TO FLAT MOUNT

Reversible for use with both 140mm and 160mm.



L-2



L-3



L-4



L-7



A-11

INTERNATIONAL STANDARD POST MOUNT

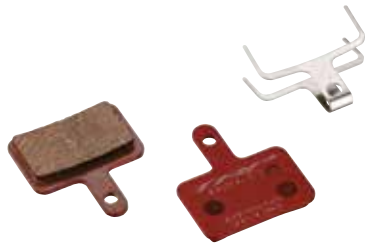

HYLEX, HY/RD, SPYRE, SPYKE PADS

SP10.11



G-SPEC, QUADIEM, SLATE T4 PADS

Q20.11



HYLEX, HY/RD, SPYRE, SPYKE PADS

F10RS



G-SPEC, QUADIEM PADS

Q10TS



INPLACE ADJUST A PAD HOLDERS

P922.11



INPLACE ADJUST M PAD HOLDERS

P956.12



INPLACE ROAD PAD HOLDERS

P961



CLAM SHELL

P950.12



CARBON RIM PADS

P961.11C



ALLOY RIM PADS

P961.11

**PARTS&ACCESSORIES**



DISCONNECT ROAD KIT



DISCONNECT MTB KIT



HYDRAULIC HOSE KIT



BANJO HOSE KIT



FORK FENDER ADAPTORS



FORK COMPRESSION CAP



HOSE COUPLER



HOSE CUTTER

**ACCESSORIES**



EUROX/REVOX BARREL ADJUSTER KIT



SPYRE COVER AND DUST BOOT



HYLEX D12 KIT



HYLEX REPLACEMENT HOODS



RRL REPLACEMENT HOODS



HYLEX D12 HOODS



SERVICE KIT

# ACCESSORIES

**AUSTRALIA**

ADVENTURE BRANDS

Tel: +61 3 9770 8912

E-mail: [tektro@adventurebrands.com.au](mailto:tektro@adventurebrands.com.au)Website: [www.adventurebrands.com.au](http://www.adventurebrands.com.au)**BENELUX**

CODAGEX

Tel: 32 (0)14347474

Email: [info@codagex.be](mailto:info@codagex.be)Website: [www.codagex.com](http://www.codagex.com)**BENELUX**

BUZAGLO B.V.

Tel: +31 (0) 36 52 10 100

Email: [info@buzaglo.nl](mailto:info@buzaglo.nl)Website: [www.buzaglo.n](http://www.buzaglo.n)**CANADA**

CYCLES LAMBERT INC

Tel: 1 855 526-2378 (Toll-Free)

Tel: 418-835-1685 (Québec)

Email: [info@cycleslambert.com](mailto:info@cycleslambert.com)Website: [www.cycleslambert.com](http://www.cycleslambert.com)**CANADA**

LIVE TO PLAY SPORTS

Tel: 604 552 2930

E-mail: [geoffp@norco.com](mailto:geoffp@norco.com)Website: [www.norco.com](http://www.norco.com)**CZECH REPUBLIC**

UNIVERSE AGENCY SPOL. S.R.O.

Tel: 224 990 777

E-mail: [petr.fiala@author.cz](mailto:petr.fiala@author.cz)Website: [www.uniag.bizl](http://www.uniag.bizl)**COLOMBIA**

DISANDINA S.A.

Tel: +(574) 4442404

E-Mail: [componentes@disandina.com](mailto:componentes@disandina.com)Website: [www.disandina.com](http://www.disandina.com)**FRANCE**

TRIBAL

TEL: 33-02-28-12-09-14

E-mail: [contact@tribal-bh.com](mailto:contact@tribal-bh.com)Webste: [www.tribal-bh.com](http://www.tribal-bh.com)**GERMANY**

MERIDA &amp; CENTURION GERMANY GMBH

Tel: 07159 9459300

E-mail: [vertrieb@merida-centurion.com](mailto:vertrieb@merida-centurion.com)Webste: [www.centurion.de](http://www.centurion.de)**JAPAN**

AKI CORPORATION LIMITED

Tel: +81-78806-0230

E-mail: [cs@akiworld.co.jp](mailto:cs@akiworld.co.jp)Website: [www.akiworld.co.jp](http://www.akiworld.co.jp)**KOREA**

COMET BICYCLE CO., LTD.

Tel: +82 31 795 8357

E-mail: [hckim@cometbicycle.com](mailto:hckim@cometbicycle.com)Website: [www.cometbicycle.com](http://www.cometbicycle.com)**RUSSIA**

ALNA-BIKE, CO.

Tel: 007 495 775 14 09

E-mail: [alna-bike@mail.ru](mailto:alna-bike@mail.ru)Website: [www.velobox.ru](http://www.velobox.ru)**TRP USA**

Bldg 4X-1

Ogden, UT 84404

Toll Free: 1-877-807-4162

Direct: 1-801-648-7079

Email: [info@trpbrakes.com](mailto:info@trpbrakes.com)**TRPCYCLING.COM**

**SCANDINAVIA**

SKIFT GEAR

Tel:

E-mail: sales@skiftgear.com

Website: www.skiftgear.com

**SOUTH AFRICA**

OMNICO (PTY) LTD

Tel: 021 691 0100

E-mail: Petri@omnico.co.za

Website: www.omnico.co.za

**SPAIN**

BICICLETAS DE ALAVA

Tel: 34-(9)45-135202

E-mail: bh@bhsa.es

Website: www.bhbikes.com

**SWITZERLAND**

TEKNO PARTS LTD

Tel: 0041 32 332 84 68

E-mail: info@teknoparts.ch

Website: www.teknoparts.ch

**UK**

UPGRADE BIKES LTD

Tel: 44(0)1403 711 611

E-mail: info@upgradebikes.co.uk

Website: www.upgradebikes.co.uk

**USA**

BTI

Tel: 800-558-8324

E-mail: info@bti-usa.com

Website: www.bti-usa.com

**USA**

DOWNEAST BICYCLE SPECIALISTS

Tel: 1-800-242-1043

E-mail: parts@debike.com

Website: www.debike.com

**USA**

GIANT BICYCLES USA

Tel: 1-805-267-4600

E-mail: Giant@GiantBicycle.com

Website: www.Giant-Bicycles.com

**USA**

HANS JOHNSON COMPANY

Tel: 800-879-1515

E-mail: sales@hjc.com

Website: www.hjc.com

**USA**

HAWLEY, LLC

Tel: 800-822-1980

E-mail: sales@hawleyusa.com

Website: www.hawleyusa.com

**USA**

KHS BICYCLES

Tel: 310-632-7173

E-mail: sales@khsbicycles.com

Website: www.khsbicycles.com

**USA**

QUALITY BICYCLE PRODUCTS

Tel: 1-888-988-8959

E-mail: customerservice@qbp.com

Website: www.qbp.com

**DISTRIBUTOR**

