

# ***INSTRUCTION MANUAL***

## ***HYDRAULIC INSTALLATION TOOLS***

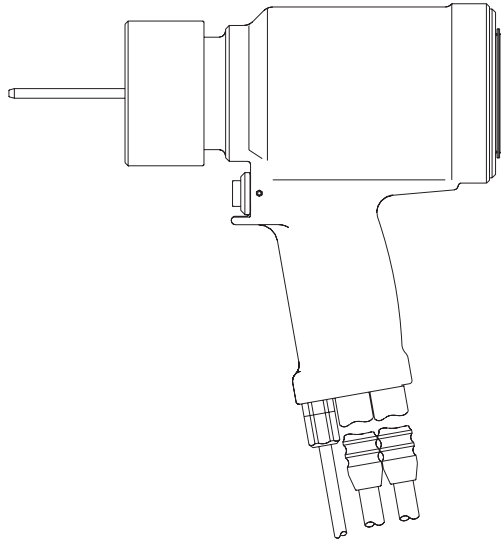

**2624**  
**2628**

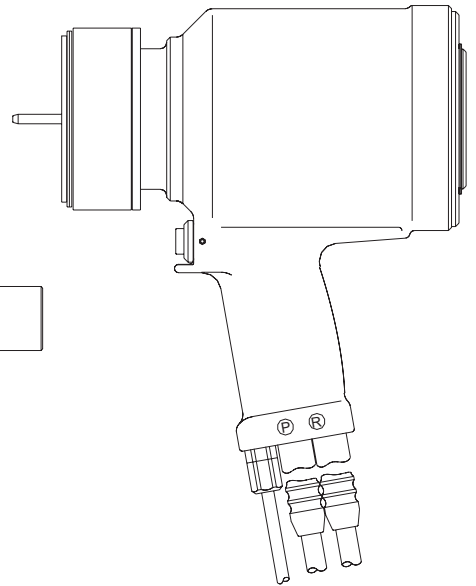

**2630**

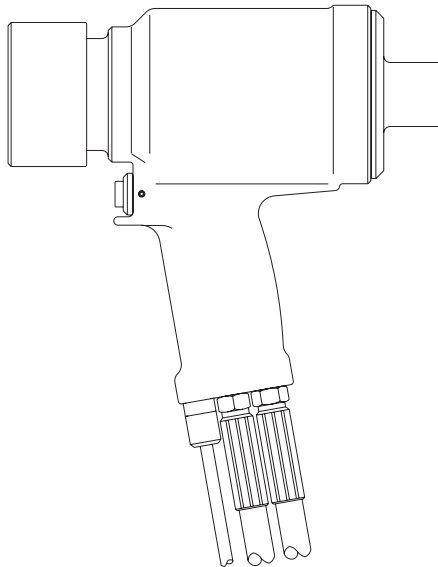

**2624HS**



---

---

# CONTENTS

---

---

<b>EU DECLARATION OF CONFORMITY</b> .....	<b>2</b>
<b>CONTENTS</b> .....	<b>3</b>
<b>SAFETY</b> .....	<b>4</b>
<b>PRINCIPLE OF OPERATION</b> .....	<b>5</b>
<b>SPECIFICATIONS</b> .....	<b>6-9</b>
<b>PREPARATION FOR USE</b> .....	<b>10</b>
<b>SERVICING THE TOOL</b>	
Good Service Practices .....	<b>10-11</b>
Preventive Maintenance .....	<b>11</b>
Disassembly .....	<b>11-12</b>
Assembly .....	<b>13-14</b>
Tool Assembly Drawings .....	<b>15-18</b>
Parts List .....	<b>19</b>
Hose Assembly Drawing .....	<b>20</b>
<b>TROUBLESHOOTING</b> .....	<b>22</b>
<b>KITS &amp; ACCESSORIES</b> .....	<b>22</b>

## SAFETY

*This instruction manual must be read with particular attention to the following safety guide lines, by any person servicing or operating this tool.*

### 1. Safety Glossary

 — Product complies with requirements set forth by the relevant European directives.

 — Read manual prior to using equipment.

 — Eye protection required while using this equipment.

 — Hearing protection required while using this equipment.



**WARNINGS - Must be understood to avoid severe personal injury.**

**CAUTIONS** - show conditions that will damage equipment and or structure.

**Notes** - are reminders of required procedures.

**Bold, Italic type and underlining** - emphasizes a specific instruction.

2. Huck equipment must be maintained in a safe working condition at all times and inspected on a regular basis for damage or wear. Any repair should be done by a qualified repairman trained on Huck procedures.
3. Repairman and Operator must read manual prior to using equipment and understand any Warning and Caution stickers/labels supplied with equipment before connecting equipment to any primary power supply. As applicable, each of the sections in this manual have specific safety and other information.
4. See MSDS Specifications before servicing the tool. MSDS Specifications are available from you Huck representative or on-line at [www.huck.com](http://www.huck.com). Click on Installation Systems Division.
5. When repairing or operating Huck installation equipment, always wear approved eye protection. Where applicable, refer to ANSI Z87.1 - 1989
6. Disconnect primary power source before doing maintenance on Huck equipment.
7. If any equipment shows signs of damage, wear, or leakage, do not connect it to the primary power supply.
8. Make sure proper power source is used at all times.
9. Never remove any safety guards or pintail deflectors.
10. Never install a fastener in free air. Personal injury from fastener ejecting may occur.
11. When using an offset nose always clear spent pintail out of nose assembly before installing the next fastener.
12. If there is a pinch point between trigger and work piece use remote trigger. (Remote triggers are available for all tooling).
13. Do not abuse tool by dropping or using it as a hammer. Never use hydraulic or air lines as a handle. Reasonable care of installation tools by operators is an important factor in maintaining tool efficiency, eliminating downtime, and in preventing an accident which may cause severe personal injury.
14. Never place hands between nose assembly and work piece.
15. Tools with ejector rods should never be cycled with out nose assembly installed.
16. When two piece lock bolts are being used always make sure the collar orientation is correct. See fastener data sheet of correct positioning.

## PRINCIPLE OF OPERATION

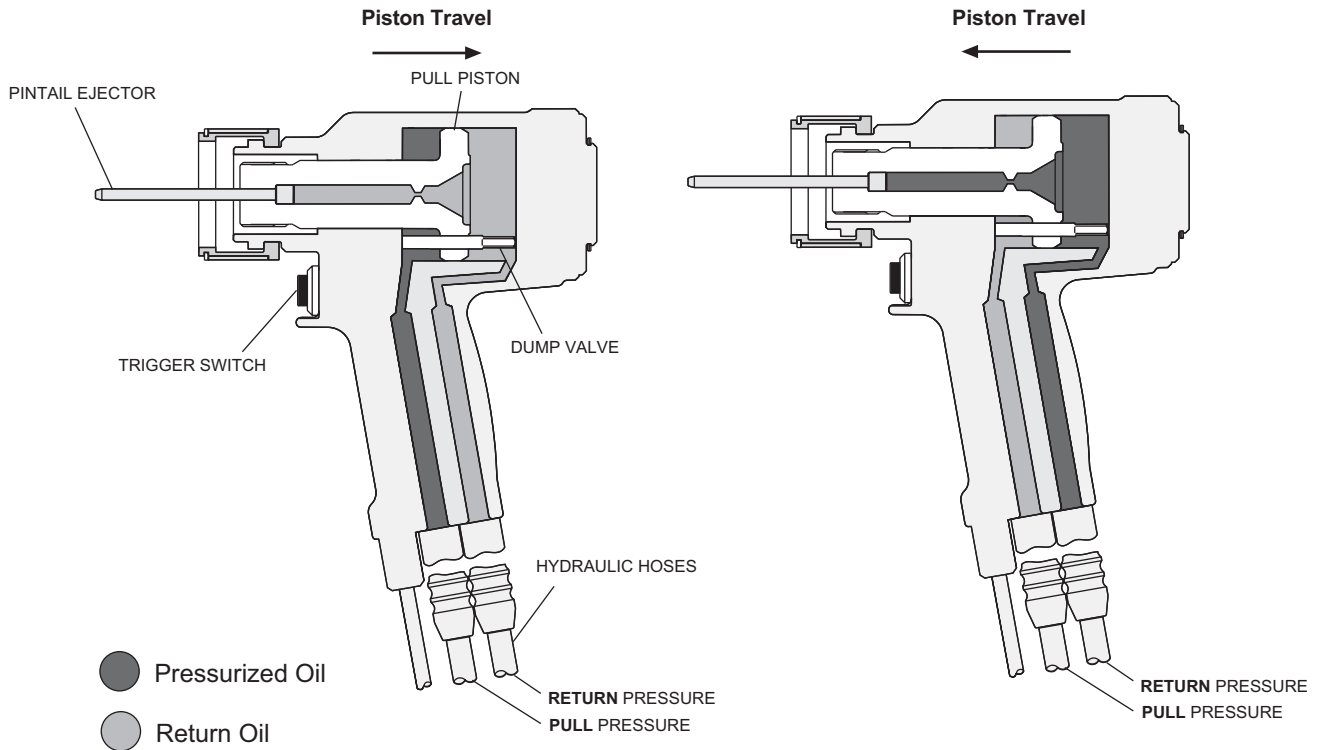

**Pull Pressure (Pull Cycle)**  
**Fig. 1(a)**

**Return Pressure (Return Cycle)**  
**Fig. 1(b)**

When the trigger is depressed, a solenoid operated valve in the POWERIG® directs pressurized hydraulic fluid through the PULL hose to the front side of the piston, and allows fluid on the RETURN side to flow back to the tank (Fig 1a). The piston and nose assembly collet moves rearward installing the fastener. When the piston reaches the end of the PULL stroke, it uncovers flats on the rear end of the unloading valve. These flats are designed to provide a passage for hydraulic fluid from the PULL side to the RETURN side of

the piston, “unloading” or “dumping” the pressurized fluid back to the tank (Fig 1a). When the trigger is released the solenoid is de-energized and the valve directs pressurized fluid to the rear side of the piston and allows fluid on the PULL side to flow back to the tank (Fig. 1b). This causes piston and collet to move forward and pushes the nose assembly and tool off the swaged (installed) fastener. When the piston reaches the end of the return stroke, pressure is built up, causing the power rig to shut off, completing the cycle.

# SPECIFICATIONS 2624

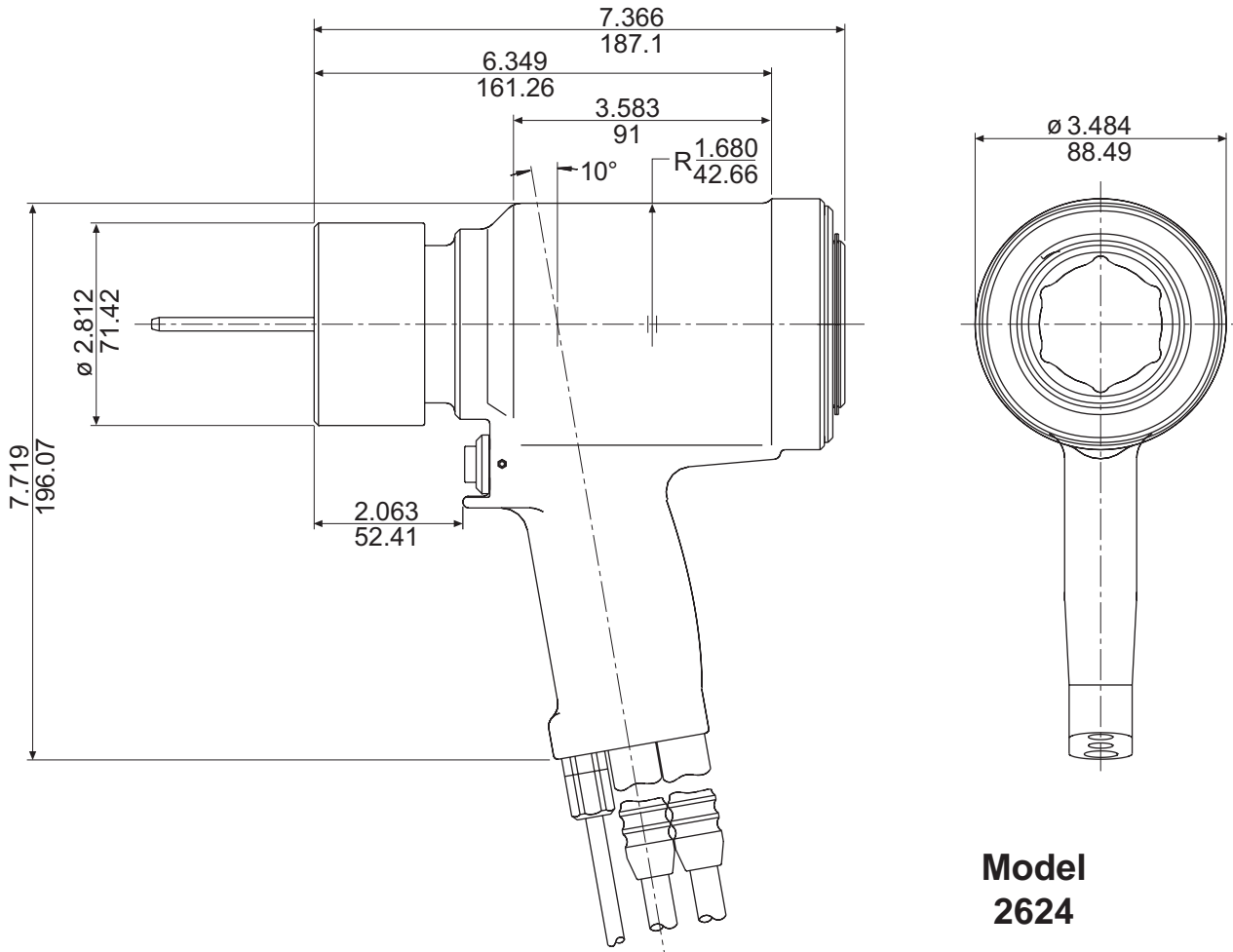

**Model  
2624**

- **Stroke:** 1.687in
- **Weight:** 17 lbs 8oz
- **Pull Pressure:** 7,400 psi
- **Return Pressure:** 3,200 psi
- **Capacity:** 30,356 lbs @ 6,500 psi
-

# SPECIFICATIONS 2624HS

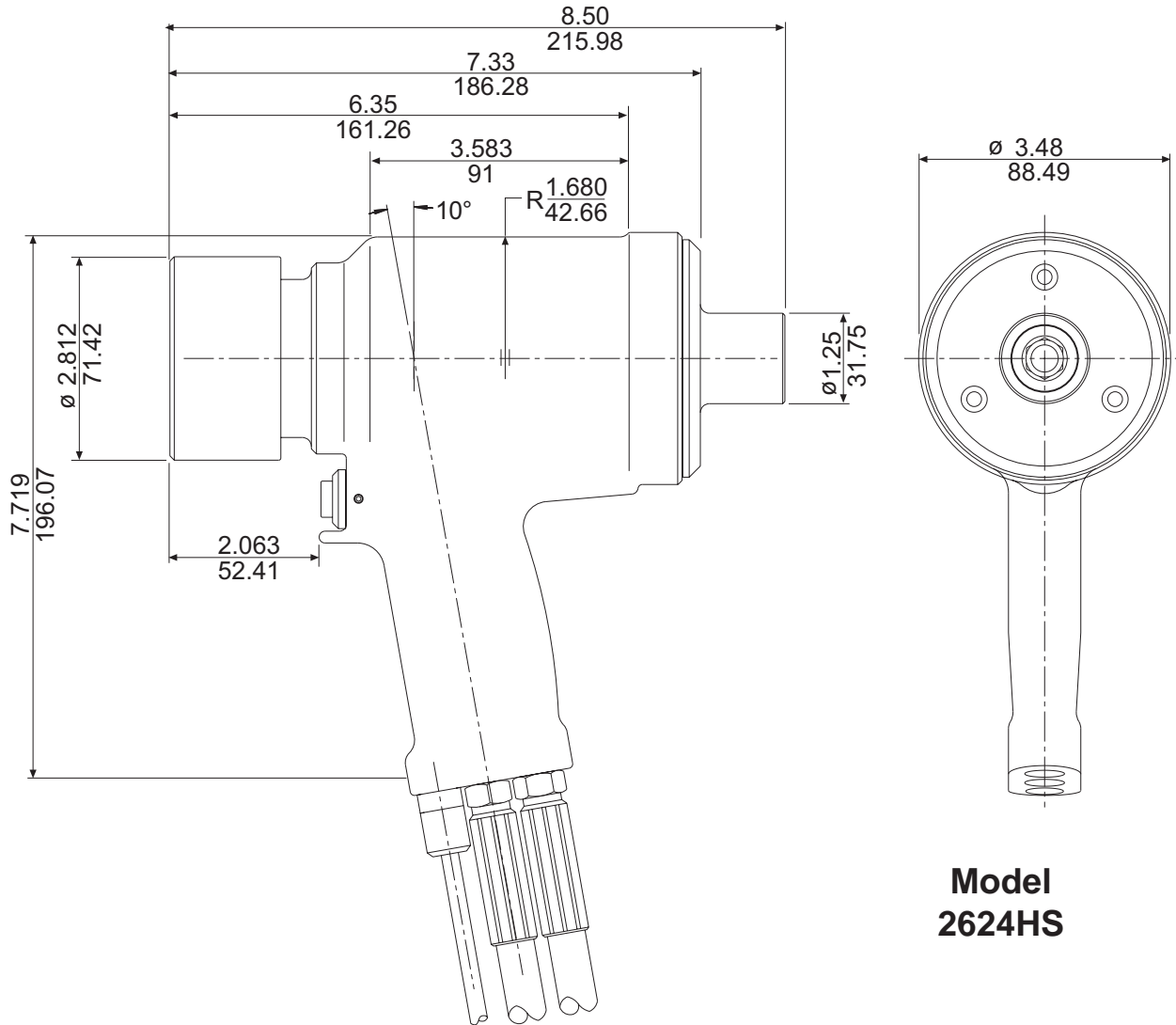

- **Stroke:** 1.687in

- **Weight:** 24 lbs

- **Pull Pressure:** 7,400 psi

- **Return Pressure:** 3,200 psi

- **Capacity:** 30,356 lbs @ 6,500 psi

-

# SPECIFICATIONS 2628

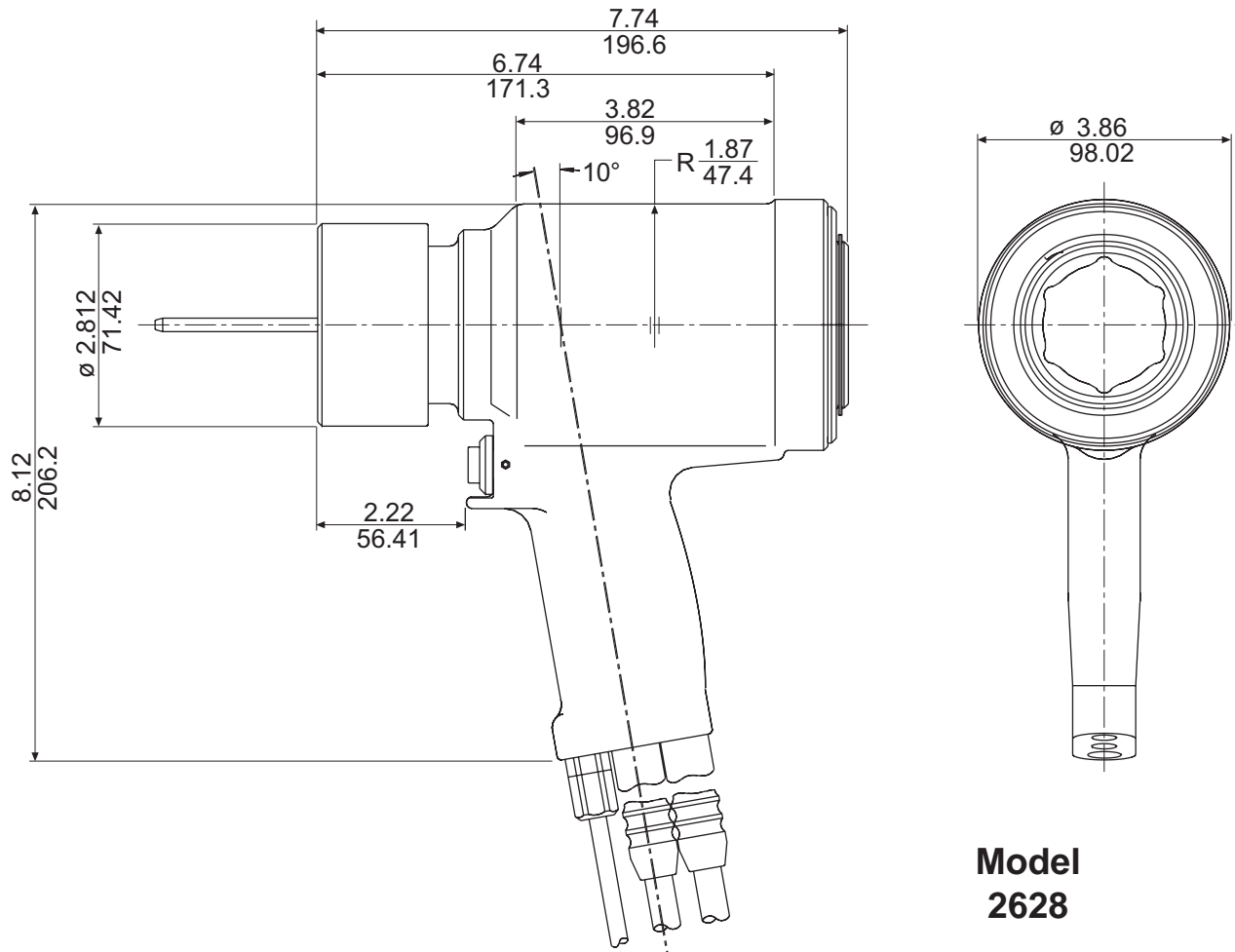

- **Stroke:** 1.812 in

- **Weight:** 20 lbs 8 oz

- **Pull Pressure:** 7,400 psi

- **Return Pressure:** 3,200 psi

- **Capacity:** 39,858 lbs @ 6,500 psi

-



# SPECIFICATIONS 2630

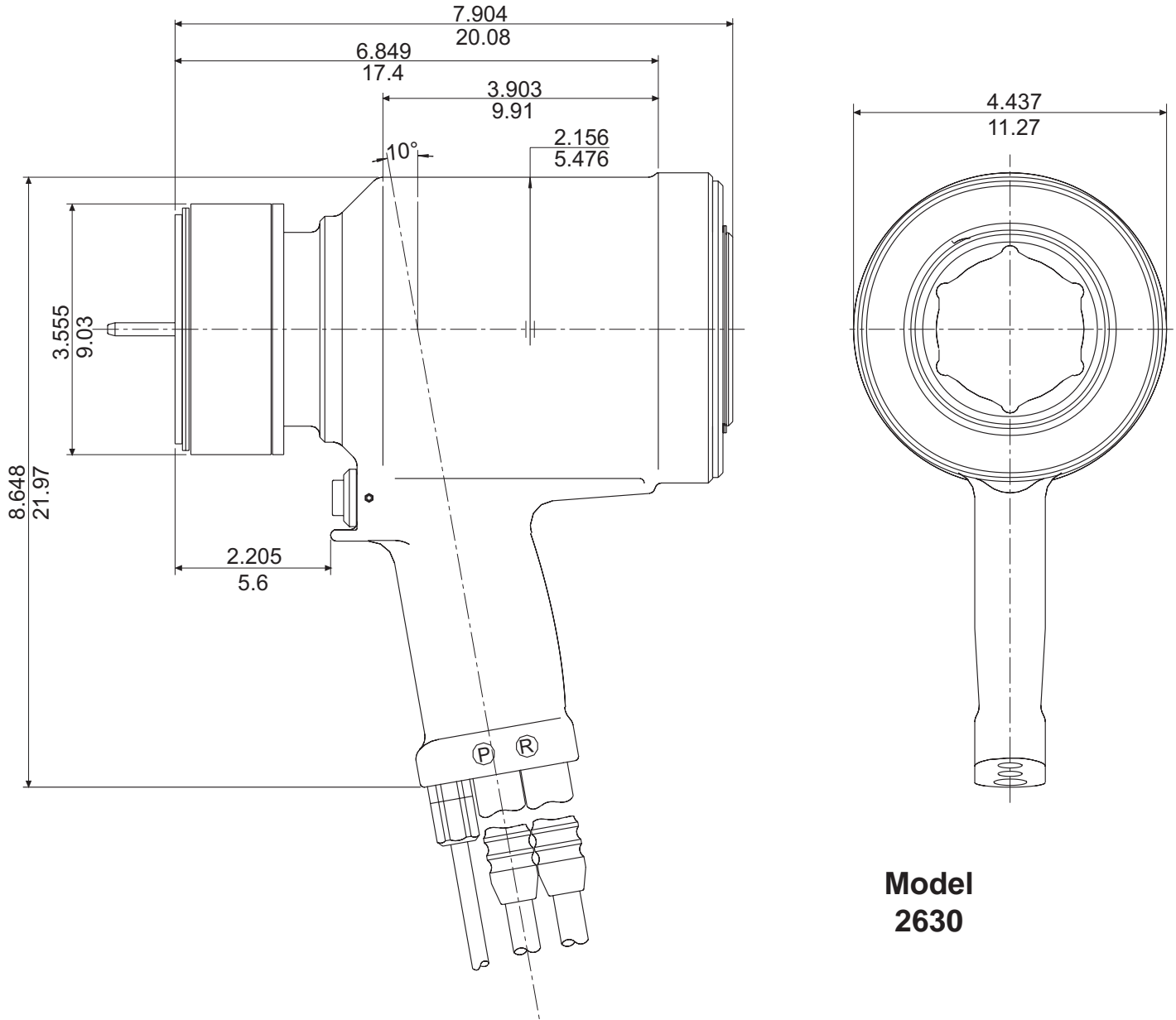

**Model  
2630**

- **Stroke:** 1.906 in
- **Weight:** 25 lbs
- **Pull Pressure:** 7,400 psi
- **Return Pressure:** 3,200 psi
- **Capacity:** 48,614 lbs @ 6,500 psi
-



## PREPARATION FOR USE

1. Use Huck POWERIG® Hydraulic Unit, or equivalent, that has been prepared for operation per applicable **instruction manual**. Check both PULL and RETURN pressures, and if required, adjust to pressures given in **specifications of this manual**.



**WARNING - Proper PULL and RETURN pressures are important for proper function of Installation Tools. Severe personal injury or damage to equipment may occur without correct pressures. Huck Pressure Gauge P/N T-10280 (old style) or the new T124833 is now available for checking these pressures using instructions furnished with the gauge and in applicable POWERIG® Hydraulic Unit instruction manuals. See Specifications.**

2. First, turn hydraulic unit to OFF, and then, disconnect power supply from unit. Connect tool's hoses to unit.



**WARNING - Be sure to connect tool hoses to hydraulic unit BEFORE connecting tool electrical switch cord to unit. Hoses and switch must be connected in this order and disconnected in the reverse order to prevent possible severe personal injury.**

3. Connect tool's control switch electrical cord to hydraulic unit.
4. Connect hydraulic unit to power supply. Turn unit to ON. Hold tool trigger depressed for 30 seconds; depress trigger a few times to cycle tool and to circulate hydraulic fluid. Observe action of tool and check for leaks. Turn unit to OFF.
5. Select nose assembly for fastener to be installed. Disconnect tool's control switch electrical cord from hydraulic unit; disconnect unit from power supply. Attach nose assembly to tool.
6. Reconnect hydraulic unit to power supply. Reconnect tool's switch control cord to unit. Check operation of nose assembly; install fasteners in test plate of correct thickness with proper size holes. Inspect installed fasteners. If fasteners do not pass inspection, see **TROUBLESHOOTING** to locate and correct tool malfunction.



## SERVICING THE TOOL

### GOOD SERVICE PRACTICES

**CAUTION:** Keep dirt and other harmful material out of hydraulic system, which includes tool, hoses, couplers and POWERIG Hydraulic Unit. Parts must be kept away from unclean work surfaces. Dirt in hydraulic system causes valve failure in hydraulic unit.

Individual parts must be handled carefully and examined for damage or wear. Replace parts where required. Always replace O-rings and Back-up Rings when tool is disassembled for any reason. See applicable Service Kit.



**WARNING: Inspect tool for damage or wear before each use. Do not operate if damaged or worn, as severe personal injury may occur**

- The efficiency and life of your tool depends on proper maintenance. Using the manual will help give a clear understanding of the tool and basic maintenance procedures. Please read this page completely before pro-

ceeding with maintenance and repair. Use proper hand tools in a clean and well-lighted area. Only standard hand tools are required in most cases. Where a special tool is required, the description and part number are given.

- While clamping tool or parts in a vise, and when parts require force, use suitable soft materials to cushion impact. For example, using a half-inch brass drift, wood block and vise with soft jaws greatly reduces possibility of damaging tool. Remove components in a straight line without bending, cocking or undue force. Reassemble tool with the same care.
- Consult **TROUBLESHOOTING** section of this manual if a malfunction occurs and then see appropriate **DISASSEMBLY; ASSEMBLY** and/or Component illustration sections.

(continued)



## SERVICING THE TOOL (cont.)

### **GOOD SERVICE PRACTICES** (continued)

#### **Sealants, Lubricants, Hydraulic Fluid & Service Kits**

- Rub SLIC-TITE TEFLON thread compound, or equivalent, on pipe threads to prevent leaks and for ease of assembly. **CAUTION:** *Do not use TEFLON tape on pipe threads.* Particles of shredded tape cause hydraulic unit valve failure. (SLIC-TITE in stick form, 503237).
- Smear LUBRIPLATE 130AA, or equivalent, on O-rings and mating surfaces to prevent damaging O-rings on rough or sharp surfaces. Also, increases ease of assembly. (LUBRIPLATE in a tube, 502723).
- Each Service Kit contains perishable parts for your specific tool. As foreseeable use may indicate, keep extra kits (O-rings, Back-up Rings, other standard items) and tool parts in stock. When stock is depleted, you can get kit items from any regular retailer of these items. See kit parts list for: O-ring size (AS568- number); material; durometer. For kit parts lists and related information, see General Notes.

### **PREVENTIVE MAINTENANCE**

#### **System Inspection**

Operating efficiency of the tool is directly related to the performance of the complete system, including the tool with nose assembly, hydraulic hoses, trigger switch and control cord, and POWERIG Hydraulic Unit. Therefore, an effective preventive maintenance program includes scheduled inspections of the system to detect and correct minor troubles.

- Inspect tool and nose assembly for external damage.
- Verify that hydraulic hose fittings and couplings, and electrical connections are secure.
- Inspect hydraulic hoses for damage and deterioration. Do not use hoses to carry tool. Replace hoses if damaged.
- Observe tool, hoses and hydraulic unit during operation to detect abnormal heating, leaks or vibration.

#### **POWERIG Hydraulic Unit Maintenance**

Refer to the applicable POWERIG instruction manual.

#### **Tool Maintenance**

Whenever disassembled and also at regular intervals (depending on severity and length of use) replace all seals, wipers and back-up rings in tool. Service Kits, hoses and extra parts should be kept in stock. Inspect cylinder bore, pistons and piston rods for scored surfaces and excessive wear or damage. Replace as necessary.

#### **Nose Assembly Maintenance**

Clean nose assembly often. Dip in mineral spirits, or similar solvent, to clean jaws and wash away metal chips and debris. At regular intervals, as experience shows, disassemble nose and use a sharp "pick" to remove imbedded particles from grooves of jaws.

### **DISASSEMBLY - ALL MODELS**

For component identification and Parts Lists refer to Figures 8-12.

#### **NOTE:**

The following procedure is for complete disassembly of tool. Disassemble **only** components necessary to replace damaged O-rings, Quad-Rings, Back-up Rings, and worn or damaged components. Always use soft jaw vice to avoid damage to tool.



**WARNING: Be sure to disconnect tool's electric control trigger system from Hydraulic Unit before disconnecting tool's hoses from unit. Before any maintenance is done, DISCONNECT IN THIS ORDER (RECONNECT IN THE OPPOSITE ORDER) to avoid possible severe personal injury.**

1. Disconnect electrical or air connector from Powerig. Uncouple tool hydraulic hoses.
2. Remove nose assembly.
3. Unscrew coupling nipple and coupling body. Drain hydraulic hoses into container. Discard fluid.
4. Push rearward on Piston (4) until remaining hydraulic fluid is drained into container. Discard fluid.



## SERVICING THE TOOL (cont.)

5. **NOTE:** Do not remove hydraulic hoses from tool unless replacing hoses. If necessary to remove hoses, uncover hose fittings by sliding plastic shrouds back.
6. **NOTE:** Use the following steps **only** if the Switch, Wire or Connector needs repair.  
Remove Retaining Nut and Locking Ferrule from Strain Relief (20). Loosen Set Screw (37) and remove Switch (21). Loosen and remove the two wires from the switch. Remove cord from tool. Disassemble electrical connector (110686).
7. **Models 2624, 2628, 2630:** (Figures 8, 10 & 11)  
Remove Retaining Ring (17), cover plate (16) and Locking Disk (18).  
**Model 2624HS:** (Figure 9)  
Remove Screws (31), Retainer (30) and Locking Disk (18).
8. Insert Hex Key 126981 (shipped with tool) in End Cap (15) (Figure 2). Using a wrench, unscrew End Cap from Cylinder.

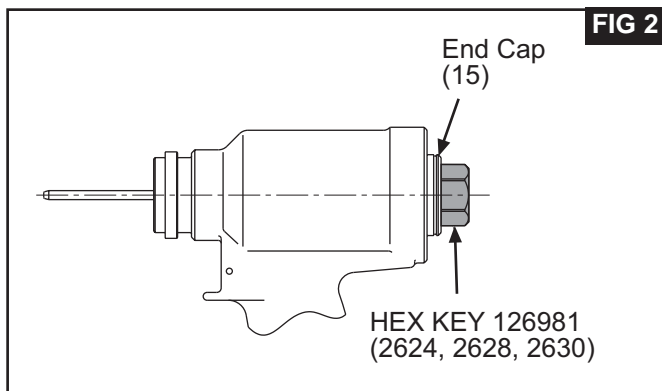

9. **Models 2624, 2628, 2630:** (Figures 8, 10 & 11)  
Remove O-ring (9) and Back-up Ring (8)  
**Model 2624HS:** (Figure 9)  
Remove O-ring (9), Back-up Ring (8), Retaining Ring (36), Washer (35), Polyseal (34) and Wiper seal (33).
10. Remove Dump Valve (19) from rear of Cylinder.
11. Slide Spacer over Piston and thread on Piston Assembly Tool. Using a press push Front Gland and Piston assemblies out of the back of the Cylinder. (Figure 3)

12. Remove Piston Assembly Tool and Spacer (Figure 3).

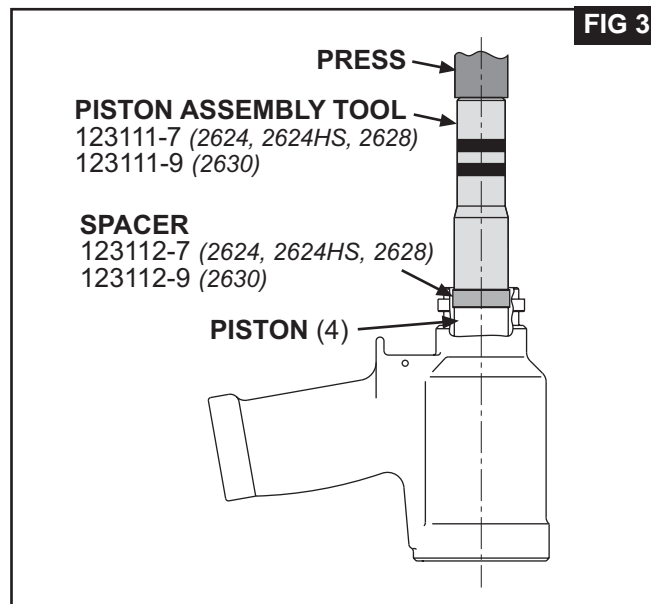

13. Slide Front Gland (11) off of Piston (4) and remove Wiper (6), Wiper Housing (7), Back-up Ring (8), O-ring (9) and Polyseal (10) (Figures 8-11).
14. Remove GLYD Ring (13) from Piston (4) (Figure 5).
15. **Models 2624, 2628, 2630:** (Figures 8, 10 & 11)  
Hold Piston (4) in a vise with soft jaws and remove Ejector Gland Assembly (22) with Hex Key 122048
16. **Models 2624, 2628, 2630:** (Figures 4, 8, 10 & 11)  
Remove from Gland, Ejector Rod (29), Washer (23), O-rings (24), Wiper (26) Quad-Ring (28) and Back-up Ring (27).

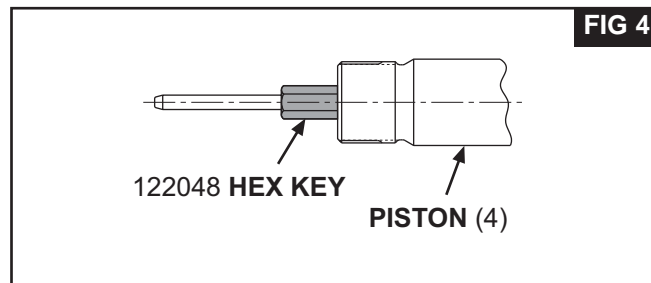



## SERVICING THE TOOL (cont.)

### ASSEMBLY All Models

For component identification and Parts Lists, refer to Figures 8-12.

**NOTE:** Clean components with mineral spirits, or similar solvent. Inspect for wear/damage and replace as necessary. Replace all seals of disassembled components. Use O-rings, Quad-Rings and Back-up Rings in **Service Parts Kit 2620KIT (all models) and 2620-PTKIT (all models)**. Smear LUBRIPLATE 130AA or PARKER-O-LUBE on O-rings, Quad-Rings, Back-up Rings and mating parts to ease assembly. Assemble tool taking care not to damage O-rings, Quad-Rings, or Back-up Rings.

- Models 2624, 2628, 2630:** (Figures 8, 10 & 11) Install Back-up Ring (27), Quad-Ring (28), Wiper (26), O-rings (24), Washer (23) and Ejector Rod (29) into Ejector Gland (25).
- Models 2624, 2628, 2630:** (Figures 4, 8, 10 & 11) Hold Piston (4) in a vise with soft jaws and install assembled Ejector Gland (22). Use Hex Key 122048 to tighten.
- Thread Piston Assembly Tool, onto Piston (4) (Figure 5). **Note: Do not install Spacer.**
- Install GLYD Ring (13) onto Piston (4) (Figure 5).

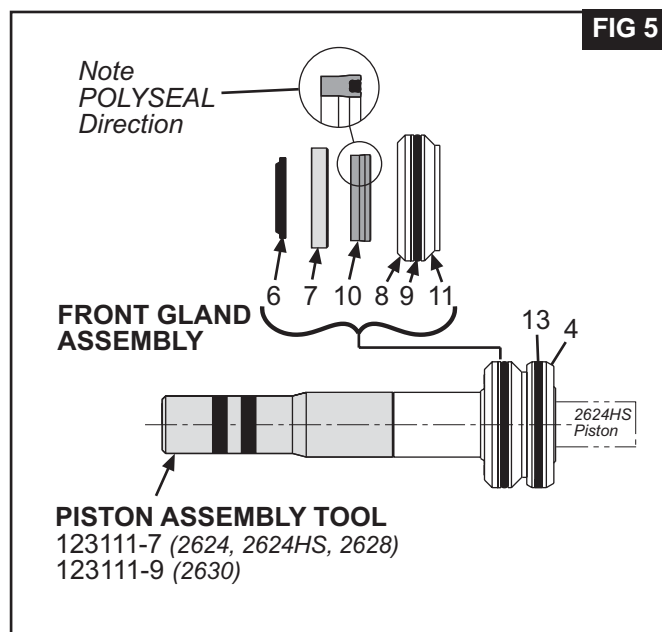

- Install Polyseal (10), O-ring (9), Back-up Ring (8), Wiper Housing (7) and Wiper (6) into Front Gland (11) (Figure 5).
- Lubricate Piston Assembly Tool and Piston, then slide assembled Gland (11) over Piston Assembly Tool onto Piston (Figure 5).
- Thread GLYD Ring Insertion Tool into the back of the Cylinder (Figure 6).

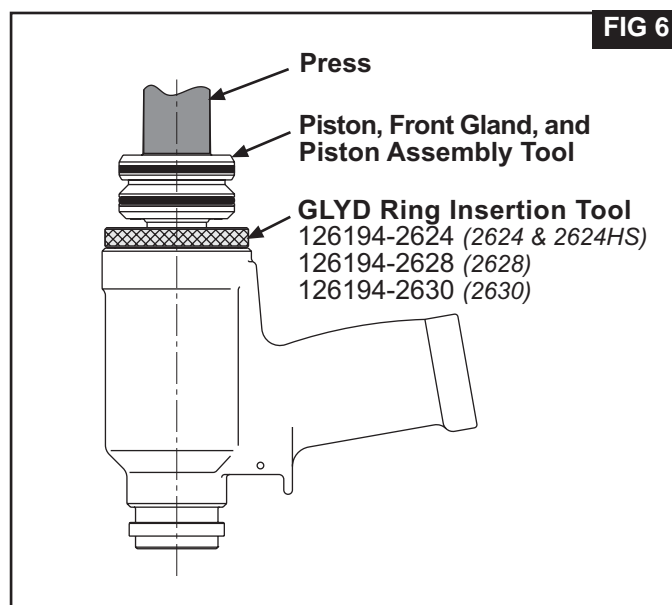

- Using a press, push Piston and Front Gland Assemblies into the back of Cylinder (5). (Figure 6)
- Remove Piston Assembly Tool (Figure 5).
- Remove the GLYD Ring Insertion Tool from the back of the Cylinder (Figure 6).
- From the rear of Cylinder, install Dump Valve (19) with the **four flats facing the rear of the tool** (Figures 8-11).

(continued)



# SERVICING THE TOOL (cont.)

12. **Models 2624, 2628, 2630:** (Figures 8, 10 & 11)  
Install O-ring (9) and Back-up Ring (8) on End Cap (15).
- Model 2624HS:** (Figures 7 & 9)  
Install Back-up Ring (8), O-ring (9), Wiper Seal (33), Polyseal (34), Washer (35) and Retaining Ring (36) into End Cap (15).

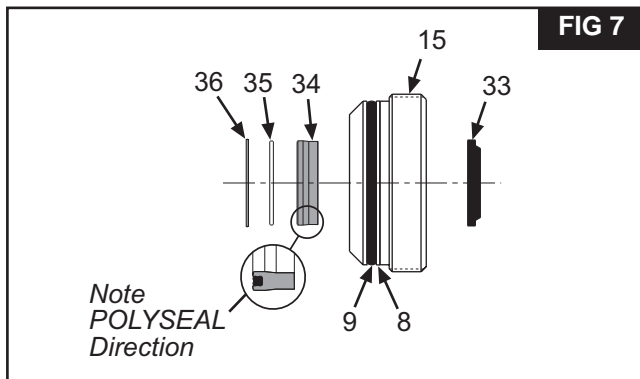

13. Insert Hex Key into the End Cap (15). Using a wrench thread the End Cap into the back of the Cylinder and tighten (Figure 2).
14. **Models 2624, 2628, 2630:** (Figures 8, 10 & 11)  
Install Locking Disk (18), Cover Plate (16) and Retaining Ring (17).
- Model 2624HS:** (Figure 9)  
Install Locking Disk (18), Barbed Retainer (30), Screws (31) and Deflector (32).

15. If removed, reinstall Electrical Connector (Figure 12).
16. **NOTE: If switch or wire have been removed, replace as follows:**  
Slide Retaining Nut and Ferrule onto Electrical Wire. Feed Wire through Handle and pull out through the Trigger Switch hole. Attach Wires to Switch (21) and push the assembly back into the Handle. Tighten Screw (37) to hold Trigger Switch in place. Slide Ferrule into Strain Relief Housing, then thread and tighten Retaining Nut (Figures 8-12).
17. If removed, install one hydraulic Hose in Handle port marked "P" and one in port marked "R".  
**CAUTION: Do not use TEFLON tape on pipe threads. (See GOOD SERVICE PRACTICES section of this manual, pages 10-11)**
18. Install Coupler Nipple 110438, (PULL pressure hose), Coupler Body 110439, (RETURN pressure hose) (Figure 12).

..... Use Area Below for Service Notes: .....



# ASSEMBLY DRAWING 2624

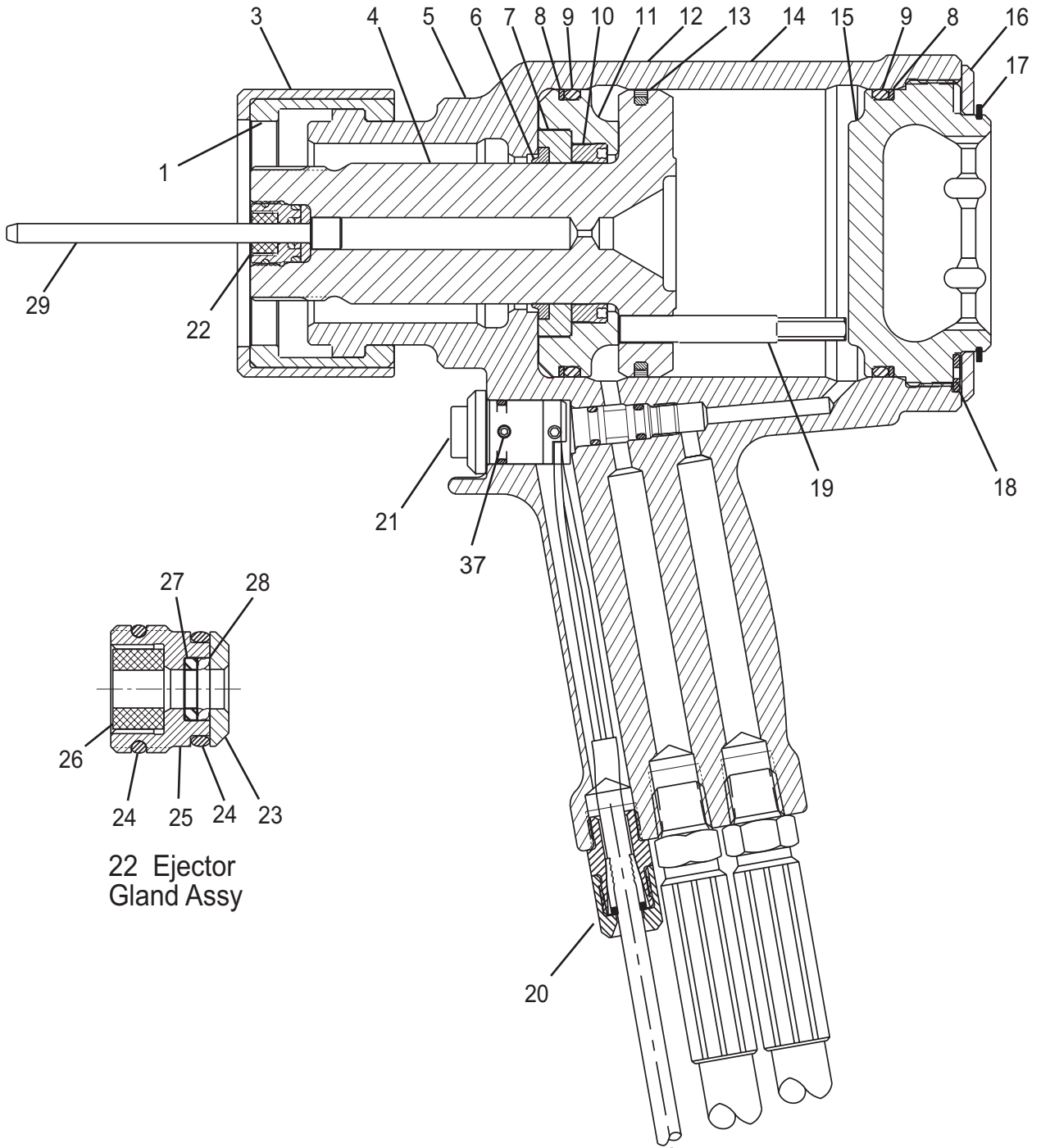

**FIGURE 8**

# ASSEMBLY DRAWING 2624HS

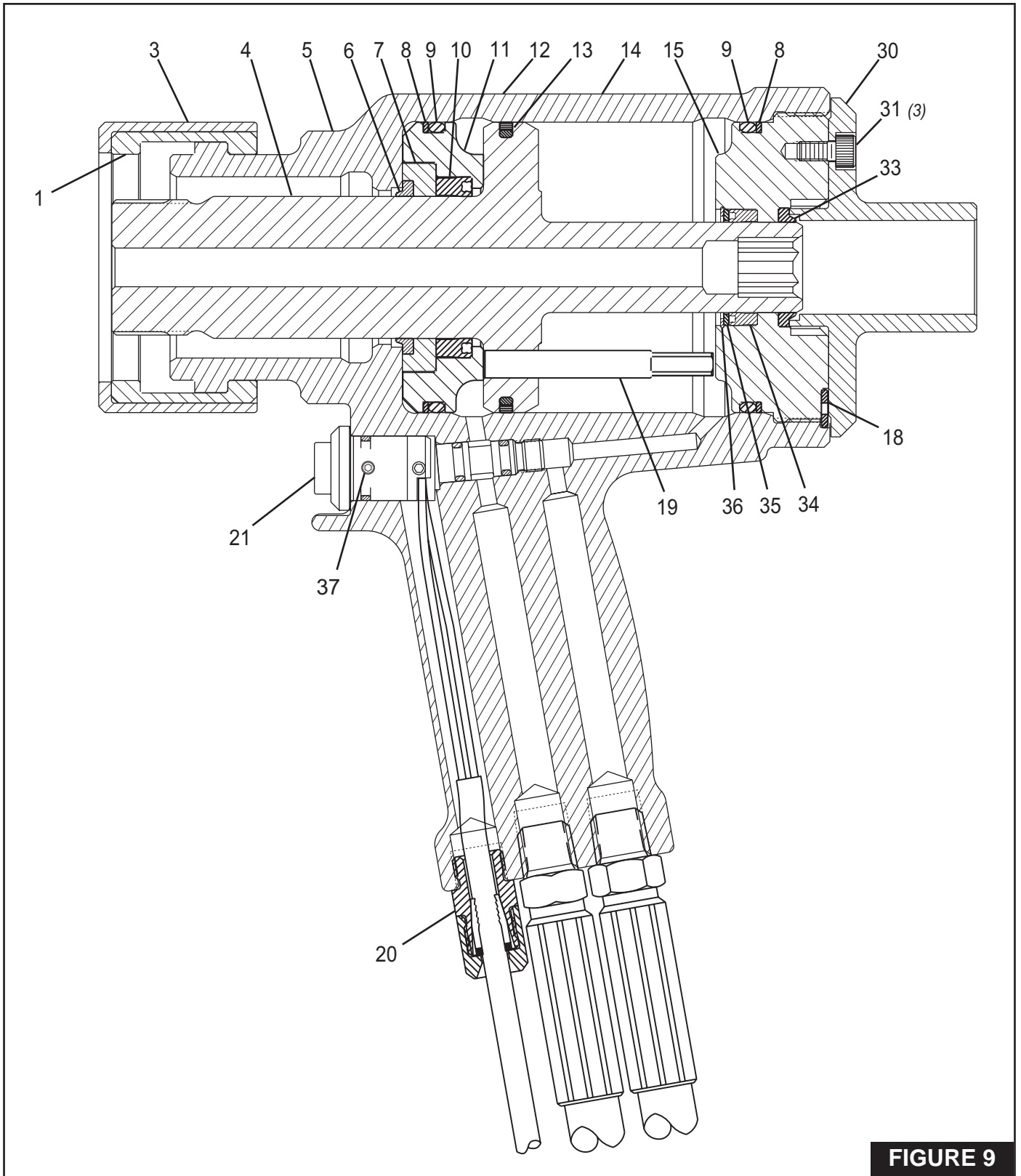

**FIGURE 9**



# ASSEMBLY DRAWING 2628

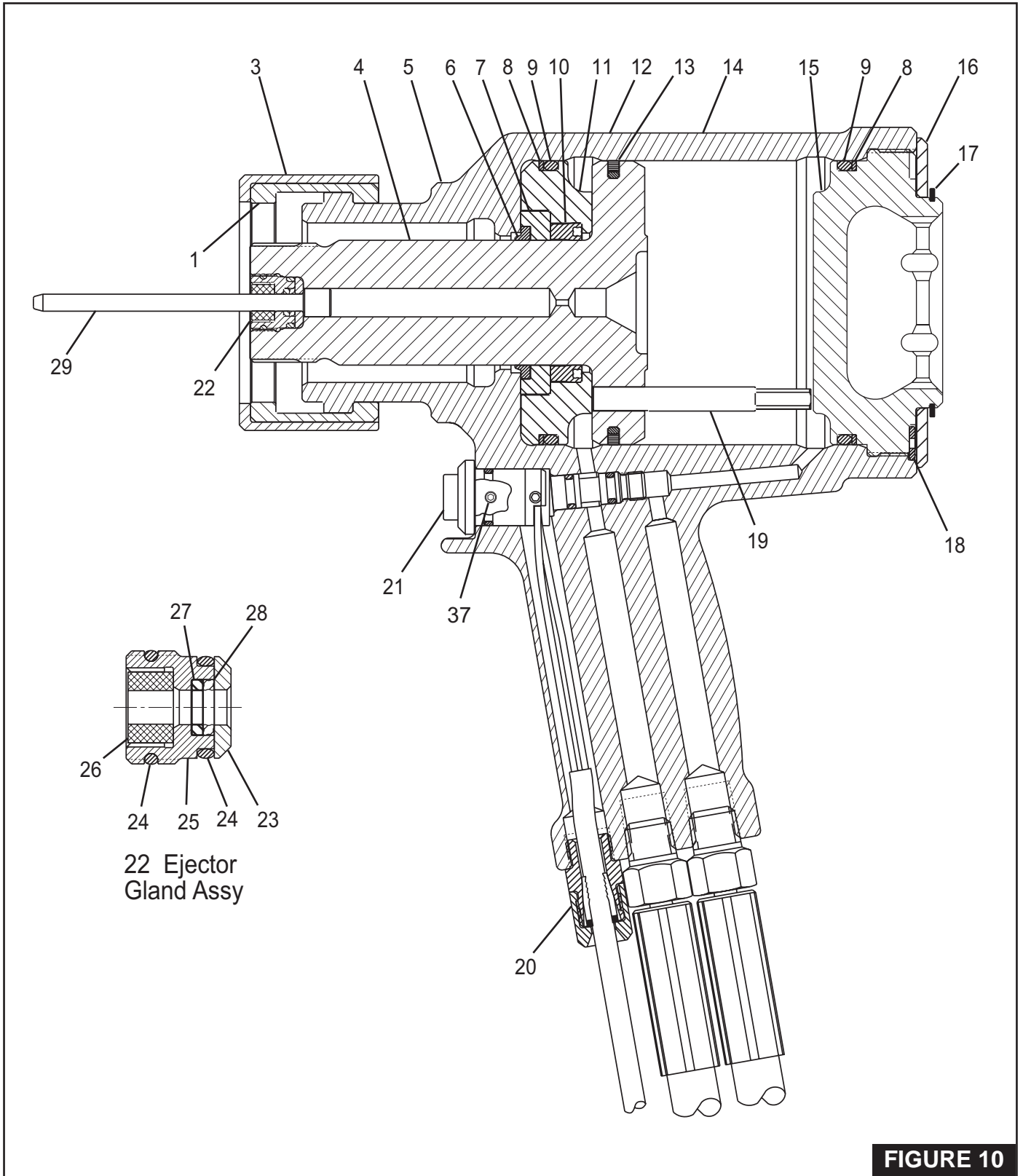

**FIGURE 10**

# ASSEMBLY DRAWING 2630

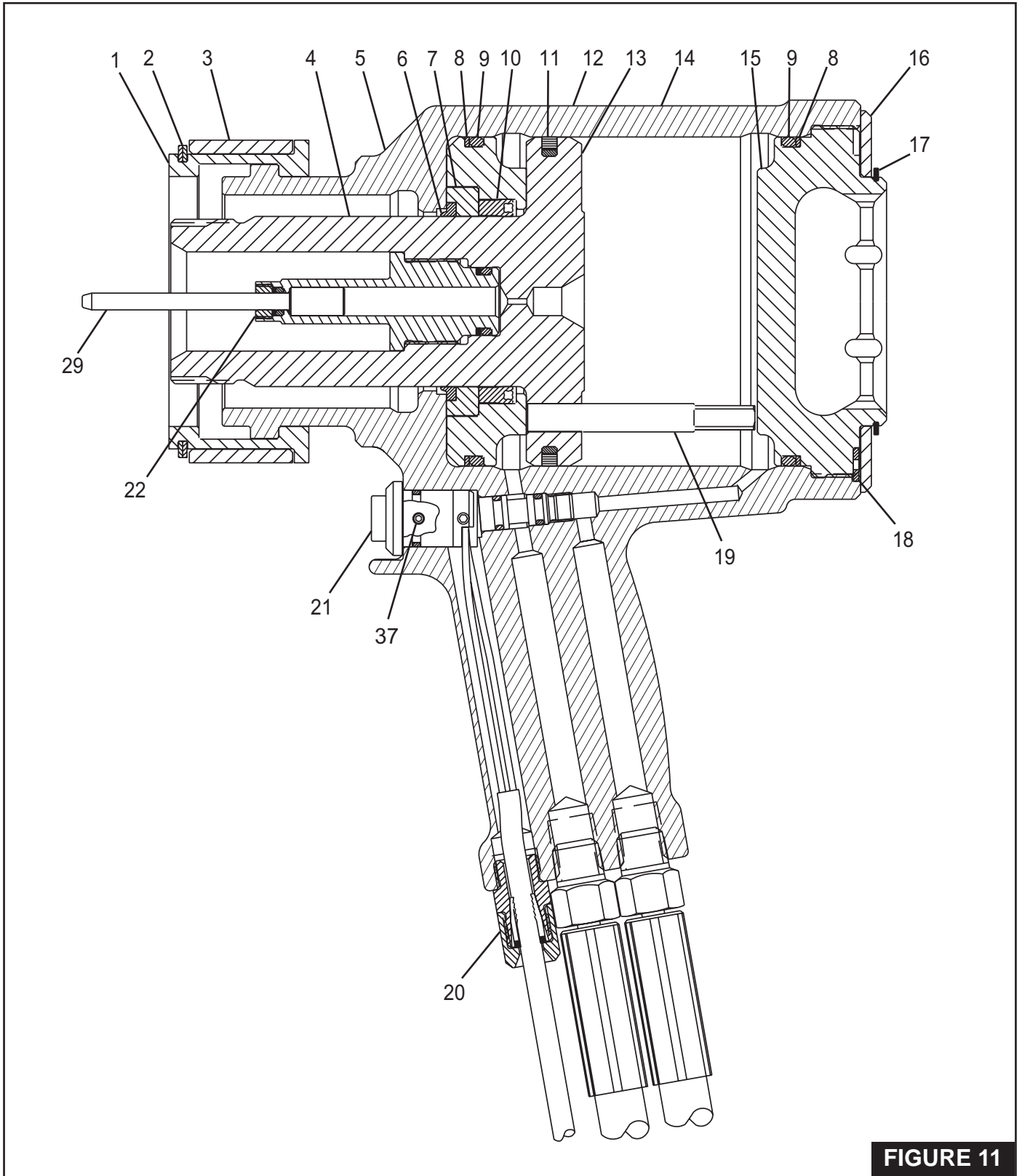

FIGURE 11

## PARTS LIST

Item	Description	Qty	2624 2624-15	2624HS	2628 2628-15	2630
1	Split Ring	1	100247	100247	100247	101394
2	Retaining Ring	1	-----	-----	-----	501533
3	Retaining Sleeve	1	100248	100248	100248	101395
4	Piston	1	125685*	127224	126193**	126958
5	Cylinder Assembly	1	126108	126108	126197	126966
6	Wiper Seal	1	500601	506001	500601	506174
7	Wiper Housing	1	125683	125683	125683	126962
8	Back-up Ring	2	125691	125691	501160	501164
9	O-ring	2	500862	500862	500865	500869
10	Polyseal	1	507417	507417	507417	506171
11	Front Gland	1	125682	125682	126195	126959
12	Caution Sticker	1	590189-1	590189-1	590189-2	590189-2
13	GLYD Ring Assembly	1	122769-2	122769-2	122769-3	122769-4
14	Warning Sticker	1	590247	590247	590247	590247
15	End Cap	1	125687	127225	126194	126961
16	Cover Plate	1	125690	-----	126196	126963
17	Retaining Ring	1	507418	-----	507418	506838
18	Locking Disc	1	122764	122764	122764	122764
19	Dump Valve	1	125689	125689	126198	126960
20	Strain Relief or Air Fitting	1	505344	505344	505344	505344
21	Trigger Switch Assembly	1	120361	120361	120361	120361
22	Ejector Gland Assembly	1	120653	-----	120653	123357
23	Ejector Washer	1	120652	-----	120652	-----
24	O-ring	2	500779	-----	500779	-----
25	Gland	1	122047	-----	122047	-----
26	Rod Wiper	1	122742	-----	122742	-----
27	Back-up Ring	1	501080	-----	501080	-----
28	Quad-Ring	1	501411	-----	501411	-----
29	Pintail Ejector	1	122705	-----	122705	122709-1
30	Retainer	1	-----	127226	-----	-----
31	Screws	3	-----	500060	-----	-----
32	Deflector	-	-----	-----	-----	-----
33	Wiper Seal	1	-----	505894	-----	-----
34	Polyseal	1	-----	506160	-----	-----
35	Spacer	1	-----	122762	-----	-----
36	Retaining Ring	1	-----	506159	-----	-----
37	Set Screw	1	501731	501731	501731	501731

\* Piston 125685 is not sold separately. It may be purchased as Piston Assembly part no. 125686, which contains Piston 125685 and GLYD Ring Assembly 122769-2.

\*\* Piston 126193 is not sold separately. It may be purchased as Piston Assembly part no. 126202, which contains Piston 126193 and GLYD Ring Assembly 122769-3.

# HOSE ASSEMBLY FOR ALL MODELS

FIG 12

MODEL SELECTION

MODEL(S)	HOSE ASSEMBLY	CONTROL CORD
2624, 2628, 2630	126107-1	123337
2624HS, 2624-15, 2628-15	126107-2	123336

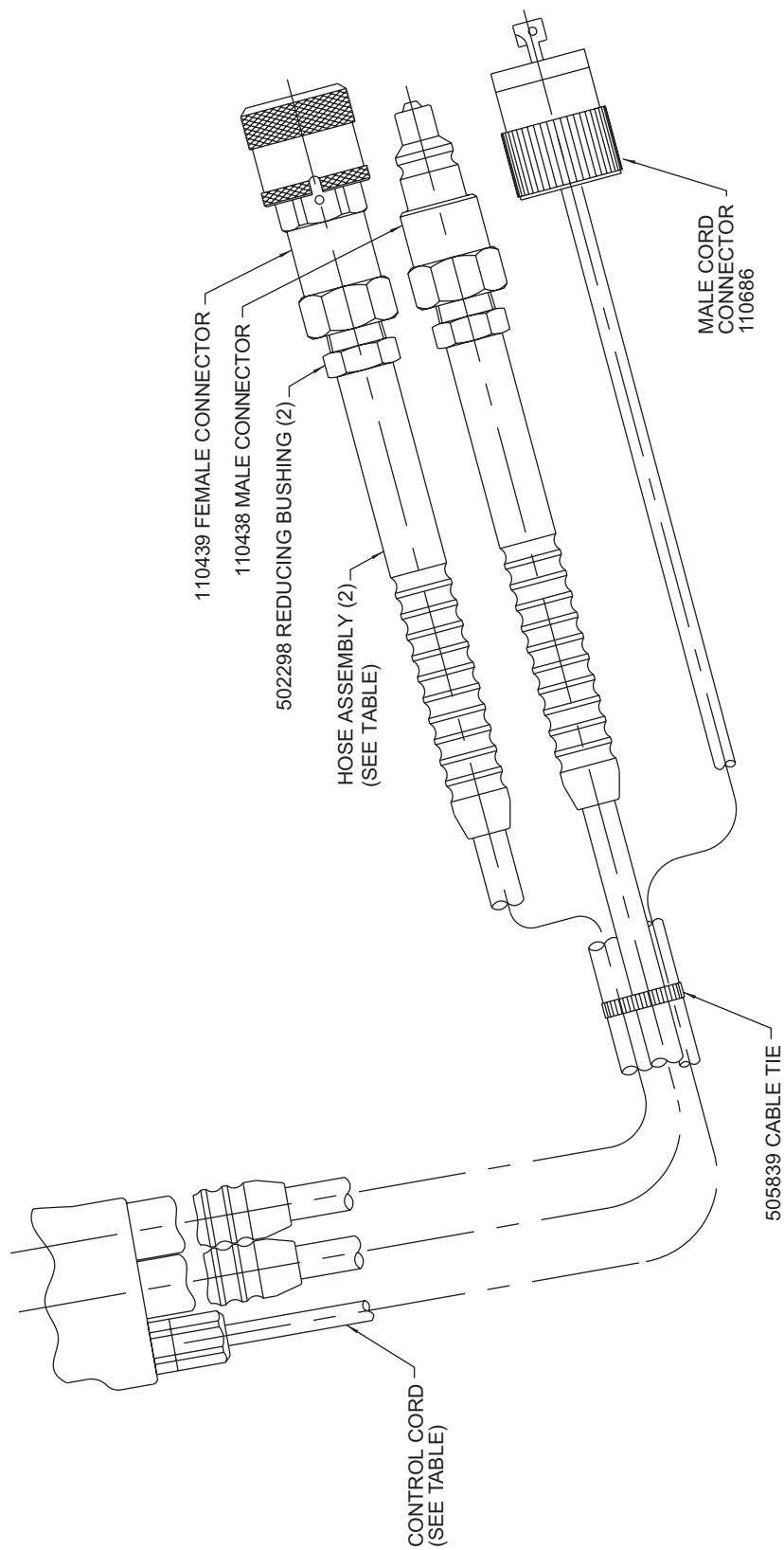

---

---

## SERVICE NOTES

---

---

## TROUBLESHOOTING

Always check the simplest possible cause of a malfunction first (example: a loose or disconnected trigger line). Then proceed logically and eliminate each possible cause until the defect is found. Where possible, substitute known good parts for suspected defective parts. Use the following steps as an aid in troubleshooting.

1. *Tool fails to operate when trigger is pressed.*
  - a. Inoperative POWERIG® Hydraulic Unit. See applicable instruction manual.
  - b. Loose electrical connections.
  - c. Damaged trigger assembly.
  - d. Loose or faulty hose coupling.
2. *Tool operates in reverse.*
  - a. Reversed hose connections between hydraulic unit and tool.
3. *Tool leaks hydraulic fluid.*
  - a. Defective tool O-rings or loose connections at tool.
4. *Hydraulic couplers leak fluid.*
  - a. Damaged or worn O-rings in Coupler Body Coupler
5. *Hydraulic fluid overheats.*
  - a. Unit not operating properly. See units manual.
  - b. Unit running in reverse (918; 918-5 only). See unit's manual.
6. *Tool operates erratically and fails to install fastener properly.*
  - a. Low or erratic hydraulic pressure. Air in system.
  - b. Damaged or worn Piston O-ring in tool.
  - c. Excessive wear on sliding surfaces of tool parts.
7. *Pull grooves on fastener pintail stripped during PULL stroke.*
  - a. Operator not sliding anvil completely onto fastener pintail.
  - b. Incorrect fastener grip.
  - c. Worn or damaged jaw segments.
  - d. Metal particles in jaw grooves.
  - e. Excessive sheet gap.
8. *Collar of fastener not completely swaged.*
  - a. Improper tool operation. See No. 6.
  - b. Scored anvil.
9. *Tool "hangs up" on swaged collar of fastener.*
  - a. Improper tool operation. See No. 6.
  - b. RETURN pressure too low.
  - c. Not enough collar lubricant.
  - d. Nose assembly not installed correctly.

10. *Pintail of fastener fails to break.*
  - a. Improper tool operation - - see No. 6.
  - b. Pull grooves on fastener stripped - - see No. 7.
  - c. PULL pressure too low.
11. *Nose will not release broken pintail.*
  - a. Nose assembly not installed correctly.

## KITS AND ACCESSORIES

### Service Kits:

2624	-	2624KIT
2624HS	-	2624HSKIT
2628	-	2628KIT
2630	-	2630KIT

### Assembly Tool Kits:

2624 & 2624HS Assembly Tool Kit	-	123110-9
<i>Includes: (Fig. 3 &amp; 6))</i>		
Spacer	-	123112-7
Piston Assembly Tool	-	123111-7
GLYD Ring Insertion Tool	-	121694-2624
2628 Assembly Tool Kit	-	123110-12
<i>Includes: (Fig. 3 &amp; 6))</i>		
Spacer	-	123112-7
Piston Assembly Tool	-	123111-7
GLYD Ring Insertion Tool	-	121694-2628
2630 Assembly Tool Kit	-	123110-13
<i>Includes: (Fig. 3 &amp; 6))</i>		
Spacer	-	123112-9
Piston Assembly Tool	-	123111-9
GLYD Ring Insertion Tool	-	121694-2630

### Accessories:

Ejector Hex Wrench (All Models)	-	122048
End Cap Hex Wrench		
2620 & 2620-PT	-	124434-1
2620-PT/A2620-PT	-	124434-1

## LIMITED WARRANTIES

**Tooling Warranty:** Huck warrants that tooling and other items (excluding fasteners, and hereinafter referred as "other items") manufactured by Huck shall be free from defects in workmanship and materials for a period of ninety (90) days from the date of original purchase.

**Warranty on "non standard or custom manufactured products":** With regard to non-standard products or custom manufactured products to customer's specifications, Huck warrants for a period of ninety (90) days from the date of purchase that such products shall meet Buyer's specifications, be free of defects in workmanship and materials. Such warranty shall not be effective with respect to non-standard or custom products manufactured using buyer-supplied molds, material, tooling and fixtures that are not in good condition or repair and suitable for their intended purpose.

**THERE ARE NO WARRANTIES WHICH EXTEND BEYOND THE DESCRIPTION ON THE FACE HEREOF. HUCK MAKES NO OTHER WARRANTIES AND EXPRESSLY DISCLAIMS ANY OTHER WARRANTIES, INCLUDING IMPLIED WARRANTIES AS TO MERCHANTABILITY OR AS TO THE FITNESS OF THE TOOLING, OTHER ITEMS, NONSTANDARD OR CUSTOM MANUFACTURED PRODUCTS FOR ANY PARTICULAR PURPOSE AND HUCK SHALL NOT BE LIABLE FOR ANY LOSS OR DAMAGE, DIRECTLY OR INDIRECTLY, ARISING FROM THE USE OF SUCH TOOLING, OTHER ITEMS, NONSTANDARD OR CUSTOM MANUFACTURED PRODUCTS OR BREACH OF WARRANTY OR FOR ANY CLAIM FOR INCIDENTAL OR CONSEQUENTIAL DAMAGES.**

Huck's sole liability and Buyer's exclusive remedy for any breach of warranty shall be limited, at Huck's option, to replacement or repair, at FOB Huck's plant, of Huck manufactured tooling, other items, nonstandard or custom products found to be defective in specifications, workmanship and materials not otherwise the direct or indirect cause of Buyer supplied molds, material, tooling or fixtures. Buyer shall give Huck written notice of claims for defects within the ninety (90) day warranty period for tooling, other items, nonstandard or custom products described above and Huck shall inspect products for which such claim is made.

**Tooling, Part(s) and Other Items not manufactured by Huck.**

**HUCK MAKES NO WARRANTY WITH RESPECT TO THE TOOLING, PART(S) OR OTHER ITEMS MANUFACTURED BY THIRD PARTIES. HUCK EXPRESSLY DISCLAIMS ANY WARRANTY EXPRESSED OR IMPLIED, AS TO THE CONDITION, DESIGN, OPERATION, MER-**

**CHANTABILITY OR FITNESS FOR USE OF ANY TOOL, PART(S), OR OTHER ITEMS THEREOF NOT MANUFACTURED BY HUCK. HUCK SHALL NOT BE LIABLE FOR ANY LOSS OR DAMAGE, DIRECTLY OR INDIRECTLY, ARISING FROM THE USE OF SUCH TOOLING, PART(S) OR OTHER ITEMS OR BREACH OF WARRANTY OR FOR ANY CLAIM FOR INCIDENTAL OR CONSEQUENTIAL DAMAGES.**

The only warranties made with respect to such tool, part(s) or other items thereof are those made by the manufacturer thereof and Huck agrees to cooperate with Buyer in enforcing such warranties when such action is necessary.

Huck shall not be liable for any loss or damage resulting from delays or nonfulfillment of orders owing to strikes, fires, accidents, transportation companies or for any reason or reasons beyond the control of the Huck or its suppliers.

### ***Huck Installation Equipment***

Huck International, Inc. reserves the right to make changes in specifications and design and to discontinue models without notice.

Huck Installation Equipment should be serviced by trained service technicians only.

Always give the Serial Number of the equipment when corresponding or ordering service parts.

Complete repair facilities are maintained by Huck International, Inc. Please contact one of the offices listed below.

#### Eastern

One Corporate Drive Kingston, New York 12401-0250  
Telephone (845) 331-7300 FAX (845) 334-7333

#### Canada

6150 Kennedy Road Unit 10, Mississauga, Ontario, L5T2J4, Canada.  
Telephone (905) 564-4825 FAX (905) 564-1963

#### Outside USA and Canada

Contact your nearest Huck International Office, see back cover.

In addition to the above repair facilities, there are Authorized Tool Service Centers (ATSC's) located throughout the United States. These service centers offer repair services, spare parts, Service Parts Kits, Service Tools Kits and Nose Assemblies. Please contact your Huck Representative or the nearest Huck office listed on the back cover for the ATSC in your area.





**For the Long Haul™**

## **A Global Organization**

*Alcoa Fastening Systems (AFS) maintains company offices throughout the United States and Canada, with subsidiary offices in many other countries. Authorized AFS distributors are also located in many of the world's*

*industrial and Aerospace centers, where they provide a ready source of AFS fasteners, installation tools, tool parts, and application assistance.*

## **Alcoa Fastening Systems world-wide locations:**

### **Americas**

**Alcoa Fastening Systems**  
**Aerospace Products**  
**Tucson Operations**  
3724 East Columbia  
Tucson, AZ 85714  
800-234-4825  
520-747-9898  
FAX: 520-748-2142

**Alcoa Fastening Systems**  
**Aerospace Products**  
**Carson Operations**  
PO Box 5268  
900 Watson Center Rd.  
Carson, CA 90749  
800-421-1459  
310-830-8200  
FAX: 310-830-1436

**Alcoa Fastening Systems**  
**Commercial Products**  
**Waco Operations**  
PO Box 8117  
8001 Imperial Drive  
Waco, TX 76714-8117  
800-388-4825  
254-776-2000  
FAX: 254-751-5259

**Alcoa Fastening Systems**  
**Commercial Products**  
**Kingston Operations**  
1 Corporate Drive  
Kingston, NY 12401  
800-431-3091  
845-331-7300  
FAX: 845-334-7333  
www.hucktools.com

**Alcoa Fastening Systems**  
**Commercial Products**  
**Canada Operations**  
6150 Kennedy Road, Unit 10  
Mississauga, Ontario L5T2J4  
Canada  
905-564-4825  
FAX: 905-564-1963

**Alcoa Fastening Systems**  
**Commercial Products**  
**Latin America Operations**  
Avenida Parque Lira. 79-402  
Tacubaya Mexico, D.F.  
C.P. 11850  
FAX: 525-515-1776  
TELEX: 1173530 LUKSME

### **Far East**

**Alcoa Fastening Systems**  
**Commercial Products**  
**Australia Operations**  
14 Viewtech Place  
Rowville, Victoria  
Australia 3178  
03-764-5500  
Toll Free: 008-335-030  
FAX: 03-764-5510

### **Europe**

**Alcoa Fastening Systems**  
**Commercial Products**  
**United Kingdom Operations**  
Unit C, Stafford Park 7  
Telford, Shropshire  
England TF3 3BQ  
01952-290011  
FAX: 0952-290459

**Alcoa Fastening Systems**  
**Aerospace Products**  
**France Operations**  
Clos D'Asseville  
BP4  
95450 Us Par Vigny  
France  
33-1-30-27-9500  
FAX: 33-1-34-66-0600



# **Alcoa Fastening Systems**



For The Long Haul, The Future of Fastening Technology, The Future of Assembly Technology, The Future of Tooling Technology, and Tools of Productivity are service marks of Huck International. Huck provides technical assistance regarding the use and application of Huck fasteners and tooling.

NOTICE: The information contained in this publication is only for general guidance with regard to properties of the products shown

and/or the means for selecting such products, and is not intended to create any warranty, express, implied, or statutory; all warranties are contained only in Huck's written quotations, acknowledgements, and/or purchase orders. It is recommended that the user secure specific, up-to-date data and information regarding each application and/or use of such products.

**HWB898 1003-5M**

*One Great Connection<sup>SM</sup>*