



Controls, Start-Up, Operation, Service, and Troubleshooting

SAFETY CONSIDERATIONS

Installing, starting up, and servicing this equipment can be hazardous due to system pressures, electrical components, and equipment location (roof, elevated structures, mechanical rooms, etc.). Only trained, qualified installers and service mechanics should install, start up, and service this equipment.

When working on this equipment, observe precautions in the literature, and on tags, stickers, and labels attached to the equipment, and any other safety precautions that apply. Follow all safety codes. Wear safety glasses and work gloves. Use care in handling, rigging, and setting this equipment, and in handling all electrical components.

⚠ WARNING

Electrical shock can cause personal injury and death. Shut off all power to this equipment during installation and service. There may be more than one disconnect switch. Tag all disconnect locations to alert others not to restore power until work is completed.

⚠ WARNING

DO NOT VENT refrigerant relief valves within a building. Outlet from relief valves must be vented outdoors in accordance with the latest edition of ANSI/ASHRAE (American National Standards Institute/American Society of Heating, Refrigeration and Air Conditioning Engineers) 15 (Safety Code for Mechanical Refrigeration). The accumulation of refrigerant in an enclosed space can displace oxygen and cause asphyxiation. Provide adequate ventilation in enclosed or low overhead areas. Inhalation of high concentrations of vapor is harmful and may cause heart irregularities, unconsciousness or death. Misuse can be fatal. Vapor is heavier than air and reduces the amount of oxygen available for breathing. Product causes eye and skin irritation. Decomposition products are hazardous.

⚠ WARNING

DO NOT attempt to unbraid factory joints when servicing this equipment. Compressor oil is flammable and there is no way to detect how much oil may be in any of the refrigerant lines. Cut lines with a tubing cutter as required when performing service. Use a pan to catch any oil that may come out of the lines and as a gage for how much oil to add to system. DO NOT re-use compressor oil.

⚠ CAUTION

This unit uses a microprocessor-based electronic control system. Do not use jumpers or other tools to short out components, or to bypass or otherwise depart from recommended procedures. Any short-to-ground of the control board or accompanying wiring may destroy the electronic modules or electrical components.

⚠ CAUTION

To prevent potential damage to heat exchanger, always run fluid through heat exchanger when adding or removing refrigerant charge. Use appropriate brine solutions in cooler fluid loop to prevent the freezing of brazed plate heat exchanger, optional hydronic section and/or interconnecting piping when the equipment is exposed to temperatures below 32 F (0 °C). Proof of flow switch and strainer are factory installed on all models. Do NOT remove power from this chiller during winter shutdown periods without taking precaution to remove all water from heat exchanger and optional hydronic system. Failure to properly protect the system from freezing may constitute abuse and may void warranty.

⚠ CAUTION

Compressors and optional hydronic system pumps require specific rotation. Test condenser fan(s) first to ensure proper phasing. Swap any two incoming power leads to correct condenser fan rotation before starting any other motors.

⚠ CAUTION

Refrigerant charge must be removed slowly to prevent loss of compressor oil that could result in compressor failure.

CONTENTS

	Page
SAFETY CONSIDERATIONS	1
GENERAL	2,3
MAJOR SYSTEM COMPONENTS	3,4
General	3
Main Base Board (MBB)	3
Scrolling Marquee Display	3
Energy Management Module (EMM)	3
Enable/Off/Remote Contact Switch	3
Emergency On/Off Switch	3
Board Addresses	3
Control Module Communication	3
Carrier Comfort Network Interface	3
OPERATING DATA	4-46
Sensors	4
• T1 — COOLER LEAVING FLUID SENSOR	
• T2 — COOLER ENTERING FLUID SENSOR	
• T7,T8 — COMPRESSOR RETURN GAS TEMPERATURE SENSOR (ACCESSORY)	
• T9 — OUTDOOR-AIR TEMPERATURE SENSOR	
• T10 — REMOTE SPACE TEMPERATURE SENSOR OR DUAL LEAVING WATER TEMPERATURE SENSOR	
Energy Management Module	17
Loss-of-Cooler Flow Protection	17
Thermostatic Expansion Valves (TXV)	17
Capacity Control	17
• MINUTES LEFT FOR START	
• MINUTES OFF TIME	
• LEAD/LAG DETERMINATION	
• CAPACITY CONTROL OVERRIDES	
Head Pressure Control	21
Operation of Machine Based on Control Method and Cooling Set Point Selection Settings	22
Cooling Set Point Select	22
Marquee Display Usage	23
Service Test	23
Optional Factory-Installed Hydronic Package	24
Cooler Pump Control	24
Cooler Pump Sequence of Operation	24
Configuring and Operating Dual Chiller Control	26
Temperature Reset	43
Demand Limit	44
• DEMAND LIMIT (2-Stage Switch Controlled)	
• EXTERNALLY POWERED DEMAND LIMIT (4 to 20 mA Controlled)	
• DEMAND LIMIT (CCN Loadshed Controlled)	
Cooling Set Point (4 to 20 mA)	45
TROUBLESHOOTING	46-57
Complete Unit Stoppage and Restart	46
• GENERAL POWER FAILURE	
• UNIT ENABLE-OFF-REMOTE CONTACT SWITCH IS OFF	
• CHILLED FLUID PROOF-OF-FLOW SWITCH OPEN	
• OPEN HIGH-PRESSURE SWITCH(ES)	
• OPEN COMPRESSOR INTERNAL THERMAL PROTECTION	
• OPEN 24-V CONTROL CIRCUIT BREAKERS	
• COOLING LOAD SATISFIED	
• THERMISTOR FAILURE	
• LOW SATURATED SUCTION	
Alarms and Alerts	53
SERVICE	58-73
Electronic Components	58
• CONTROL COMPONENTS	
Compressor Replacement	58
Cooler	58
• BRAZED-PLATE COOLER HEAT EXCHANGER REPLACEMENT	
• BRAZED-PLATE COOLER HEAT EXCHANGER CLEANING	
Check Oil Charge	60

	Page
Condenser Section and Coils	60
• COIL CLEANING	
• CLEANING E-COATED COILS	
• CONDENSER SECTION	
Check Refrigerant Feed Components	61
• THERMOSTATIC EXPANSION VALVE (TXV)	
• FILTER DRIER	
• MOISTURE-LIQUID INDICATOR	
• MINIMUM LOAD VALVE	
• PRESSURE RELIEF DEVICES	
Compressor and Unit Protective Devices	62
• MANUAL STARTER	
• COMPRESSOR INTERNAL THERMAL PROTECTION	
Check Unit Safeties	62
• HIGH-PRESSURE SWITCH	
• PRESSURE TRANSDUCERS	
• COOLER FREEZE-UP PROTECTION	
• HEATER CABLE	
• WINTER SHUTDOWN	
Thermistors	63
Pressure Transducers	63
Flow Sensor	63
Strainer	68
Motormaster® V Controller	68
• GENERAL OPERATION	
• SET POINTS	
• INSTALLATION	
• PROGRAMMING	
• EPM CHIP	
• LIQUID LINE PRESSURE SET POINT ADJUSTMENT	
• LOSS OF CCN COMMUNICATIONS	
• REPLACING DEFECTIVE MODULES	
Hydronic Package	73
MAINTENANCE	74
Recommended Maintenance Schedule	74
PRE-START-UP	74
System Check	74
START-UP AND OPERATION	74-76
Actual Start-Up	74
Check Refrigerant Charge	75
Operating Limitations	75
• TEMPERATURES	
• LOW AMBIENT OPERATION	
• VOLTAGE — ALL UNITS	
OPERATION SEQUENCE	76
APPENDIX A — CCN TABLES	77-88
APPENDIX B — FACTORY SETTINGS FOR COMPRESSOR, FAN, PUMP AND MANUAL STARTERS	89,90
APPENDIX C — BUILDING INTERFACE	91,92
START-UP CHECKLIST FOR 30RA LIQUID CHILLER	CL-1-CL-8

GENERAL

This publication contains Controls Start-Up, Service, Operation, and Troubleshooting information for the 30RA AquaSnap® air-cooled chillers. See Table 1. These chillers are equipped with *ComfortLink*™ controls and conventional thermostatic expansion valves (TXVs).

▲ WARNING

This unit uses a microprocessor-based electronic control system. Do not use jumpers or other tools to short out or bypass components or otherwise depart from recommended procedures. Any short-to-ground of the control board or accompanying wiring may destroy the board or electrical component.

Table 1 — Unit Sizes

UNIT	NOMINAL CAPACITY (TONS) 50/60 Hz
30RA010	10/10
30RA015	14/13
30RA018	16/16
30RA022	22/20
30RA025	24/23
30RA030*	27
30RA032†	30
30RA035	35/34
30RA040*	38
30RA042†	40
30RA045	43/45
30RA050*	47
30RA055*	54

*60 Hz only.
†50 Hz only.

MAJOR SYSTEM COMPONENTS

General — The 30RA air-cooled reciprocating chillers contain the *ComfortLink*[™] electronic control system that controls and monitors all operations of the chiller.

The control system is composed of several components as listed in the sections below. See Fig. 1 and 2 for typical control box drawing. See Fig. 3-6 for control schematics.

Main Base Board (MBB) — See Fig. 7. The MBB is the heart of the *ComfortLink* control system. It contains the major portion of operating software and controls the operation of the machine. The MBB continuously monitors input/output channel information received from its inputs and from all other modules. The MBB receives inputs from the discharge and suction pressure transducers and thermistors. See Table 2. The MBB also receives the feedback inputs from each compressor contactor, auxiliary contacts, and other status switches. See Table 3. The MBB also controls several outputs. Relay outputs controlled by the MBB are shown in Table 4. Information is transmitted between modules via a 3-wire communication bus or LEN (Local Equipment Network). The CCN (Carrier Comfort Network) bus is also supported. Connections to both LEN and CCN buses are made at TB3. See Fig. 8.

Scrolling Marquee Display — This standard device is the keypad interface used for accessing chiller information, reading sensor values, and testing the chiller. The marquee display is a 4-key, 4-character, 16-segment LED (light-emitting diode) display. Eleven mode LEDs are located on the display as well as an Alarm Status LED. See Marquee Display Usage section on page 23 for further details.

Energy Management Module (EMM) — The EMM module is available as a factory-installed option or as a field-installed accessory. The EMM module receives 4 to 20 mA inputs for the leaving fluid temperature reset, cooling set point and demand limit functions. The EMM module also receives the switch inputs for the field-installed 2-stage demand limit and ice done functions. The EMM module communicates the status of all inputs with the MBB, and the MBB adjusts the control point, capacity limit, and other functions according to the inputs received.

Enable/Off/Remote Contact Switch — The Enable/Off/Remote Contact switch is a 3-position switch used to control the chiller. When switched to the Enable position the chiller is under its own control. Move the switch to the Off position to shut the chiller down. Move the switch to the Remote Contact position and a field-installed dry contact can be used to start the chiller. The contacts must be capable of handling a 24 vac, 50-mA load. In the Enable and Remote

Contact (dry contacts closed) positions, the chiller is allowed to operate and respond to the scheduling configuration, CCN configuration and set point data. See Fig. 8.

Emergency On/Off Switch — The Emergency On/Off switch should only be used when it is required to shut the chiller off immediately. Power to the MBB, EMM, and marquee display is interrupted when this switch is off and all outputs from these modules will be turned off.

Board Addresses — The Main Base Board (MBB) has a 3-position Instance jumper that must be set to '1.' All other boards have 4-position DIP switches. All switches are set to 'On' for all boards.

Control Module Communication

RED LED — Proper operation of the control boards can be visually checked by looking at the red status LEDs (light-emitting diodes). When operating correctly, the red status LEDs should be blinking in unison at a rate of once every 2 seconds. If the red LEDs are not blinking in unison, verify that correct power is being supplied to all modules. Be sure that the Main Base Board (MBB) is supplied with the current software. If necessary, reload current software. If the problem still persists, replace the MBB. A red LED that is lit continuously or blinking at a rate of once per second or faster indicates that the board should be replaced.

GREEN LED — The MBB has one green LED. The Local Equipment Network (LEN) LED should always be blinking whenever power is on. All other boards have a LEN LED which should be blinking whenever power is on. Check LEN connections for potential communication errors at the board J3 and/or J4 connectors. Communication between modules is accomplished by a 3-wire sensor bus. These 3 wires run in parallel from module to module. The J4 connector on the MBB provides both power and communication directly to the marquee display only.

YELLOW LED — The MBB has one yellow LED. The Carrier Comfort Network (CCN) LED will blink during times of network communication.

Carrier Comfort Network (CCN) Interface — The 30RA chiller units can be connected to the CCN if desired. The communication bus wiring is a shielded, 3-conductor cable with drain wire and is supplied and installed in the field. See Table 5. The system elements are connected to the communication bus in a daisy chain arrangement. The positive pin of each system element communication connector must be wired to the positive pins of the system elements on either side of it. This is also required for the negative and signal ground pins of each system element. Wiring connections for CCN should be made at TB3. Consult the CCN Contractor's Manual for further information.

NOTE: Conductors and drain wire must be 20 AWG (American Wire Gage) minimum stranded, tinned copper. Individual conductors must be insulated with PVC, PVC/nylon, vinyl, Teflon, or polyethylene. An aluminum/polyester 100% foil shield and an outer jacket of PVC, PVC/nylon, chrome vinyl, or Teflon with a minimum operating temperature range of -20 C to 60 C is required. Wire manufactured by Alpha (2413 or 5463), American (A22503), Belden (8772), or Columbia (02525) meets the above mentioned requirements.

It is important when connecting to a CCN communication bus that a color coding scheme be used for the entire network to simplify the installation. It is recommended that red be used for the signal positive, black for the signal negative, and white for the signal ground. Use a similar scheme for cables containing different colored wires.

At each system element, the shields of its communication bus cables must be tied together. If the communication bus is entirely within one building, the resulting continuous shield must be connected to a ground at one point only. If the communication bus cable exits from one building and enters another, the shields must be connected to grounds at the lightning suppressor in each building where the cable enters or exits the building (one point per building only). To connect the unit to the network:

1. Turn off power to the control box.
2. Cut the CCN wire and strip the ends of the red (+), white (ground), and black (-) conductors. (Substitute appropriate colors for different colored cables.)
3. Connect the red wire to (+) terminal on TB3 of the plug, the white wire to COM terminal, and the black wire to the (-) terminal.
4. The RJ14 CCN connector on TB3 can also be used, but is only intended for temporary connection (for example, a laptop computer running Service Tool).

IMPORTANT: A shorted CCN bus cable will prevent some routines from running and may prevent the unit from starting. If abnormal conditions occur, unplug the connector. If conditions return to normal, check the CCN connector and cable. Run new cable if necessary. A short in one section of the bus can cause problems with all system elements on the bus.

Table 2 — Thermistor Designations

THERMISTOR NO.	PIN CONNECTION POINT	THERMISTOR INPUT
T1	J8-13,14 (MBB)	Cooler Leaving Fluid
T2	J8-11,12 (MBB)	Cooler Entering Fluid
T7	J8-1,2 (MBB)	Circuit A Return Gas Temperature (Accessory)
T8	J8-3,4 (MBB)	Circuit B (032-055 only) Return Gas Temperature (Accessory)
T9	J8-7,8 (MBB)	Outdoor-Air Temperature Sensor
T10	J8-5,6 (MBB) TB5-5,6	Accessory Remote Space Temperature Sensor or Dual LWT Sensor

LEGEND

LWT — Leaving Water Temperature
 MBB — Main Base Board

Table 3 — Status Switches

STATUS SWITCH	PIN CONNECTION POINT
Chilled Water Pump 1	J7-1,2
Chilled Water Pump 2	J7-3,4
Remote On/Off	TB5-9,10
Cooler Flow Switch	J7-9,10
Compressor Fault Signal, A1	J9-11,12
Compressor Fault Signal, A2	J9-5,6
Compressor Fault Signal, B1	J9-8,9
Compressor Fault Signal, B2	J9-2,3

Table 4 — Output Relays

RELAY NO.	DESCRIPTION
K1	Energize Compressor A1 (010-030) Energize Compressor A1 and Condenser Fan A1 (032-055)
K2	Energize Compressor B1 and Condenser Fan B1 at Low Speed (032-040) Energize Compressor B1 and Condenser Fan B1 (042-055)
K3	Energize Chilled Water Pump 1 Output
K4	Energize Chilled Water Pump 2 Output
K5	Energize Compressor A2 (all but 010, 015 60Hz)
K6	Energize Compressor B2 (042-055 only)
K7	Alarm Relay
K8	Cooler/Pump Heater
K9	Energize Condenser Fan at Low Speed (010-018) Energize Condenser Fan A1 (022-030) Energize Condenser Fan A2 (032-055)
K10	Energize Condenser Fan at High Speed (010-018) Energize Condenser Fan A2 (022-030) Energize Condenser Fan B1 at High Speed (032-040) Energize Condenser Fan B2 (042-055)
K11	Minimum Load Valve

Table 5 — CCN Communication Bus Wiring

MANUFACTURER	PART NO.	
	Regular Wiring	Plenum Wiring
Alpha	1895	—
American	A21451	A48301
Belden	8205	884421
Columbia	D6451	—
Manhattan	M13402	M64430
Quabik	6130	—

OPERATING DATA

Sensors — The electronic control uses 3 to 6 thermistors to sense temperatures for controlling chiller operation. See Table 2. These sensors are outlined below. Thermistors T1, T2, T9 and accessory suction gas temperatures (T7,T8) are 5 kΩ at 77 F (25 C) and are identical in temperature versus resistance and voltage drop performance. Thermistor T10 is 10 kΩ at 77 F (25 C) and has a different temperature vs. resistance and voltage drop performance. See Thermistors section for temperature-resistance-voltage drop characteristics.

T1 — COOLER LEAVING FLUID SENSOR — On 30RA010-030 sizes, this thermistor is installed in a friction fit well at the bottom of the brazed-plate heat exchanger on the control box side. For 30RA032-055 sizes, this thermistor is installed in a well in the factory-installed leaving fluid piping coming from the bottom of the brazed-plate heat exchanger opposite the control box side.

T2 — COOLER ENTERING FLUID SENSOR — On 30RA010-030 sizes, this thermistor is installed in a friction fit well at the top of the brazed-plate heat exchanger on the control box side. For 30RA032-055 sizes, this thermistor is installed in a well in the factory-installed entering fluid piping coming from the top of the brazed-plate heat exchanger opposite the control box side.

T7,T8 — COMPRESSOR RETURN GAS TEMPERATURE SENSOR (ACCESSORY) — A well for this sensor is factory installed in each circuit's suction line. If desired, a 5 kΩ thermistor (Carrier part number HH79NZ029) can be installed in this well and connected to the Main Base Board as shown in Table 2. Use the Scrolling Marquee display to configure the sensor (Configuration mode, sub-mode OPT1 — enable item RG.EN).

T9 — OUTDOOR-AIR TEMPERATURE SENSOR — This sensor is factory-installed on a bracket at the left side of compressor A1 on 30RA010-030 models. For models 30RA032-055, it is installed behind the panel below the control box center door.

T10 — REMOTE SPACE TEMPERATURE SENSOR OR DUAL LEAVING WATER TEMPERATURE SENSOR —

One of two inputs can be connected to TB5-5 and TB5-6. See appropriate sensor below.

T10 — Remote Space Temperature Sensor — Sensor T10 (part no. 33ZCT55SPT) is an accessory sensor that is remotely mounted in the controlled space and used for space temperature reset. The sensor should be installed as a wall-mounted thermostat would be (in the conditioned space where it will not be subjected to either a cooling or heating source or direct exposure to sunlight, and 4 to 5 ft above the floor).

Space temperature sensor wires are to be connected to terminals in the unit main control box. The space temperature sensor includes a terminal block (SEN) and a RJ11 female connector. The RJ11 connector is used access into the Carrier Comfort Network (CCN) at the sensor.

To connect the space temperature sensor (Fig. 9):

1. Using a 20 AWG twisted pair conductor cable rated for the application, connect 1 wire of the twisted pair to one SEN terminal and connect the other wire to the other SEN terminal located under the cover of the space temperature sensor.
2. Connect the other ends of the wires to terminals 5 and 6 on TB5 located in the unit control box.

Units on the CCN can be monitored from the space at the sensor through the RJ11 connector, if desired. To wire the RJ11 connector into the CCN (Fig. 10):









IMPORTANT: The cable selected for the RJ11 connector wiring **MUST** be identical to the CCN communication bus wire used for the entire network. Refer to Table 5 for acceptable wiring.

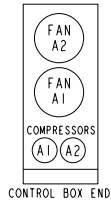
1. Cut the CCN wire and strip ends of the red (+), white (ground), and black (–) conductors. (If another wire color scheme is used, strip ends of appropriate wires.)
2. Insert and secure the red (+) wire to terminal 5 of the space temperature sensor terminal block.
3. Insert and secure the white (ground) wire to terminal 4 of the space temperature sensor.
4. Insert and secure the black (–) wire to terminal 2 of the space temperature sensor.

5. Connect the other end of the communication bus cable to the remainder of the CCN communication bus.

T10 — Dual Leaving Water Temperature Sensor — For dual chiller applications (parallel only are supported), connect the dual chiller leaving fluid temperature sensor (5 kΩ thermistor, Carrier part no. HH79NZ029) to the space temperature input of the Master chiller. If space temperature is required for reset applications, connect the sensor to the Slave chiller and configure the slave chiller to broadcast the value to the Master chiller.

LEGEND FOR FIG. 1-6

ALMR	— Alarm Relay
BR	— Boiler Relay
C	— Contactor, Compressor
CB	— Circuit Breaker
CCB	— Compressor Circuit Breaker
CHC	— Cooler/Pump Heater Contactor
COMP	— Compressor
CWFS	— Chilled Water Flow Switch
CWP	— Chilled Water Pump
DPT	— Discharge Pressure Transducer
EMM	— Energy Management
FIOP	— factory Installed Option
FM	— Fan Motor
GND	— Ground
HPS	— High-Pressure Switch
HR	— Heat Relay
ICP	— Inrush Current Protection
IP	— Internal Protection Thermostat
LWT	— Leaving Water Temperature
MBB	— Main Base Board
MLV	— Minimum Load Valve
MS	— Manual Starter
OAT	— Outdoor-Air Thermistor
OL	— Overload
R	— Relay
SPT	— Suction Pressure Transducer
SW	— Switch
T	— Thermistor
TB	— Terminal Block
TNKR	— Storage Tank Heater Relay
TRAN	— Transformer
	Terminal Block
	Terminal (Unmarked)
	Terminal (Marked)
	Splice
	Factory Wiring
	Field Wiring
	Accessory or Option Wiring
	To indicate common potential only; not to represent wiring.



- NOTES:
1. FACTORY WIRING IS IN ACCORDANCE WITH UL 1995 STANDARDS. ANY FIELD MODIFICATIONS OR ADDITIONS MUST BE IN COMPLIANCE WITH ALL APPLICABLE CODES.
 2. USE 15°C MIN WIRE FOR FIELD POWER SUPPLY.
 3. ALL COMPRESSOR MANUAL STARTERS "MUST TRIP AMPS" ARE EQUAL TO OR LESS THAN 156% RLA. ALL OTHER MANUAL STARTERS "MUST TRIP AMPS" ARE EQUAL TO OR LESS THAN 401% FLA.
 4. ALL FIELD INTERLOCK CONTACTS MUST HAVE A MIN RATING OF 2 AMPS @ 24VAC SEALED. SEE FIELD INTERLOCK WIRING.
 5. COMPRESSOR AND FAN MOTORS ARE THERMALLY PROTECTED - THREE PHASE MOTORS PROTECTED AGAINST PRIMARY SINGLE PHASE CONDITIONS.
 6. INTERCHANGE FAN MOTOR CONNECTIONS 1 AND 3 TO ENSURE COUNTER CLOCKWISE FAN ROTATION.
 7. TERMINALS 9 & 10 OF TB5 ARE FOR FIELD CONNECTION OF REMOTE ON-OFF. THE CONTACT MUST BE RATED FOR DRY CIRCUIT APPLICATION CAPABLE OF HANDLING A 5VDC 1 MA TO 20 MA LOAD.
 8. ALARM RELAY MUST BE INSTALLED FOR HEATING/BOILER RELAY OPERATION. DPST RELAY MUST BE USED FOR HEAT RELAY.
 9. FOR 500 SERIES UNIT OPERATION AT 208-3-60V LINE VOLTAGE, TRANT PRIMARY CONNECTIONS MUST BE MOVED TO TERMINALS H3 & H4.

FUSE NUMBER	UNIT VOLTAGE	TRANSFORMER SIZE	REPLACE WITH
FU1 & FU2	380-3-60, 460-3-60, 575-3-60	100VA	FNO-R-3/4
FU3 (24V)	208/230-3-60, 230-3-50, 380/415-3-50		FNO-R-2
FU4 (115V)	380-3-60, 460-3-60, 575-3-60	100VA	FNM-6
FU5 & FU6	208/230-3-60, 230-3-60	500VA	FNM-6
	460-3-60, 575-3-60	500VA	FNO-R-2 1/2
	208/230-3-60, 230-3-60	500VA	FNO-R-3 1/2

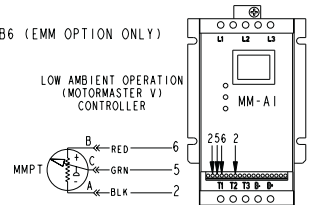
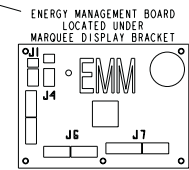
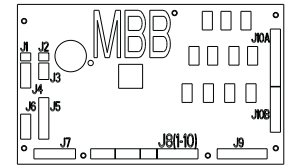
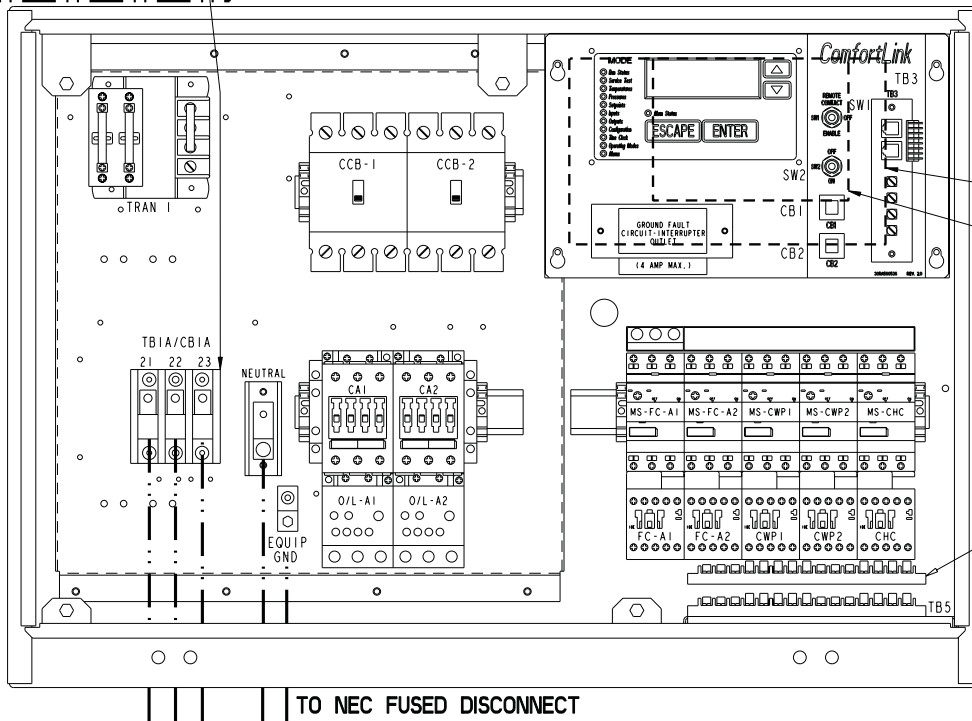
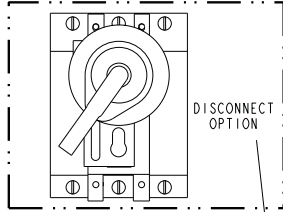
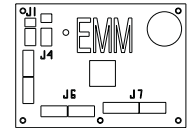


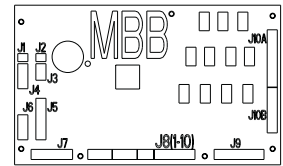
Fig. 1 — Typical Control Box for 30RA010-030 (022-030 Shown)



ENERGY MANAGEMENT BOARD
LOCATED UNDER
SCROLLING MARQUEE BRACKET

- NOTES:
- FACTORY WIRING IS IN ACCORDANCE WITH UL 1995 STANDARDS. ANY FIELD MODIFICATIONS OR ADDITIONS MUST BE IN COMPLIANCE WITH ALL APPLICABLE CODES.
 - USE 75°C MIN WIRE FOR FIELD POWER SUPPLY.
 - ALL COMPRESSOR MANUAL STARTERS "MUST TRIP AMPS" ARE EQUAL TO OR LESS THAN 156% FLA. ALL OTHER MANUAL STARTERS "MUST TRIP AMPS" ARE EQUAL TO OR LESS THAN 140% FLA.
 - ALL FIELD INTERLOCK CONTACTS MUST HAVE A MIN RATING OF 2 AMPS @ 24VAC SEALED. SEE FIELD INTERLOCK WIRING.
 - COMPRESSOR AND FAN MOTORS ARE THERMALLY PROTECTED-- THREE PHASE MOTORS PROTECTED AGAINST PRIMARY SINGLE PHASE CONDITIONS.
 - INTERCHANGE FAN MOTOR CONNECTIONS 1 AND 3 TO ENSURE COUNTER CLOCKWISE FAN ROTATION.
 - TERMINALS 9 & 10 OF TB5 ARE FOR FIELD CONNECTION OF REMOTE ON-OFF. THE CONTACT MUST BE RATED FOR DRY CIRCUIT APPLICATION CAPABLE OF HANDLING A 5VDC 1 MA TO 20 MA LOAD.
 - ALARM RELAY MUST BE INSTALLED FOR HEATING/BOILER RELAY OPERATION. DPST RELAY MUST BE USED FOR HEAT RELAY.
 - FOR 500 SERIES UNIT OPERATION AT 208-3-60V LINE VOLTAGE, TRAN1 PRIMARY CONNECTIONS MUST BE MOVED TO TERMINALS H3 & H4.

FUSE NUMBER	UNIT VOLTAGE	TRANSFORMER SIZE	REPLACE WITH
FU1 & FU2	380-3-60, 460-3-60, 575-3-60	200VA	FNO-R-1 1/2
	208/230-3-60, 230-3-50, 380/415-3-50		FNO-R-3
FU3	380-3-60, 460-3-60, 575-3-60	200VA	FNM-10
	208/230-3-60, 230-3-50, 380/415-3-50		
FU4	460-3-60, 575-3-60	500VA	FNM-6
(115V)	208/230-3-60, 230-3-60		
FU5 & FU6	460-3-60, 575-3-60	500VA	FNO-R-2 1/2
	208/230-3-60, 230-3-60		FNO-R-3 1/2



MAIN BASE BOARD
LOCATED UNDER
SCROLLING MARQUEE
BRACKET

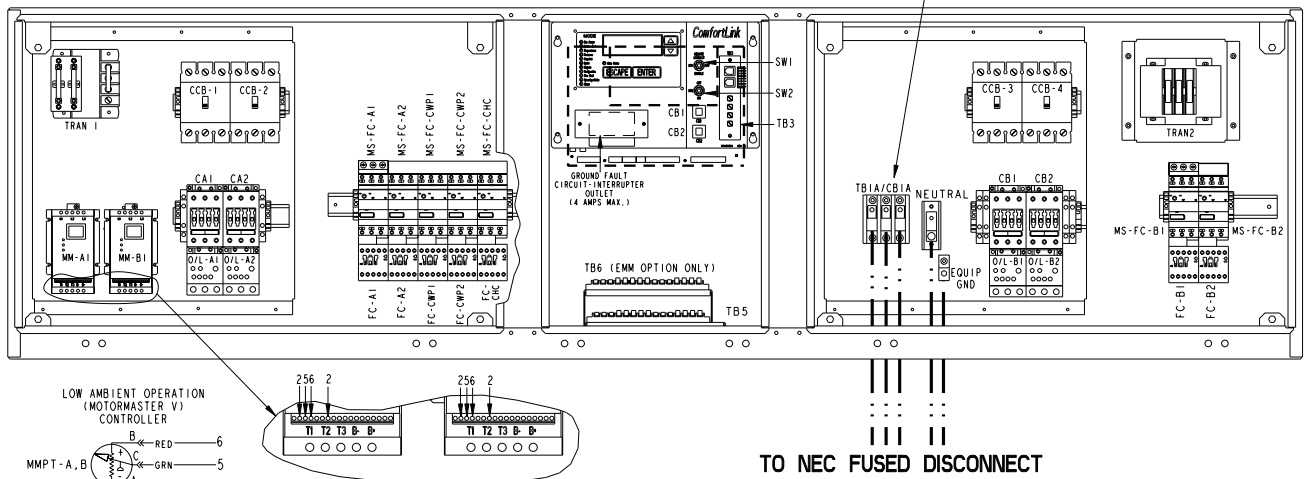


Fig. 2 — Typical Control Box for 30RA032-055 (042-055 Shown)

30RA010-018 AQUA SNAP

UNIT POWER DISCONNECT OPTION STANDARD UNIT ALL MODELS

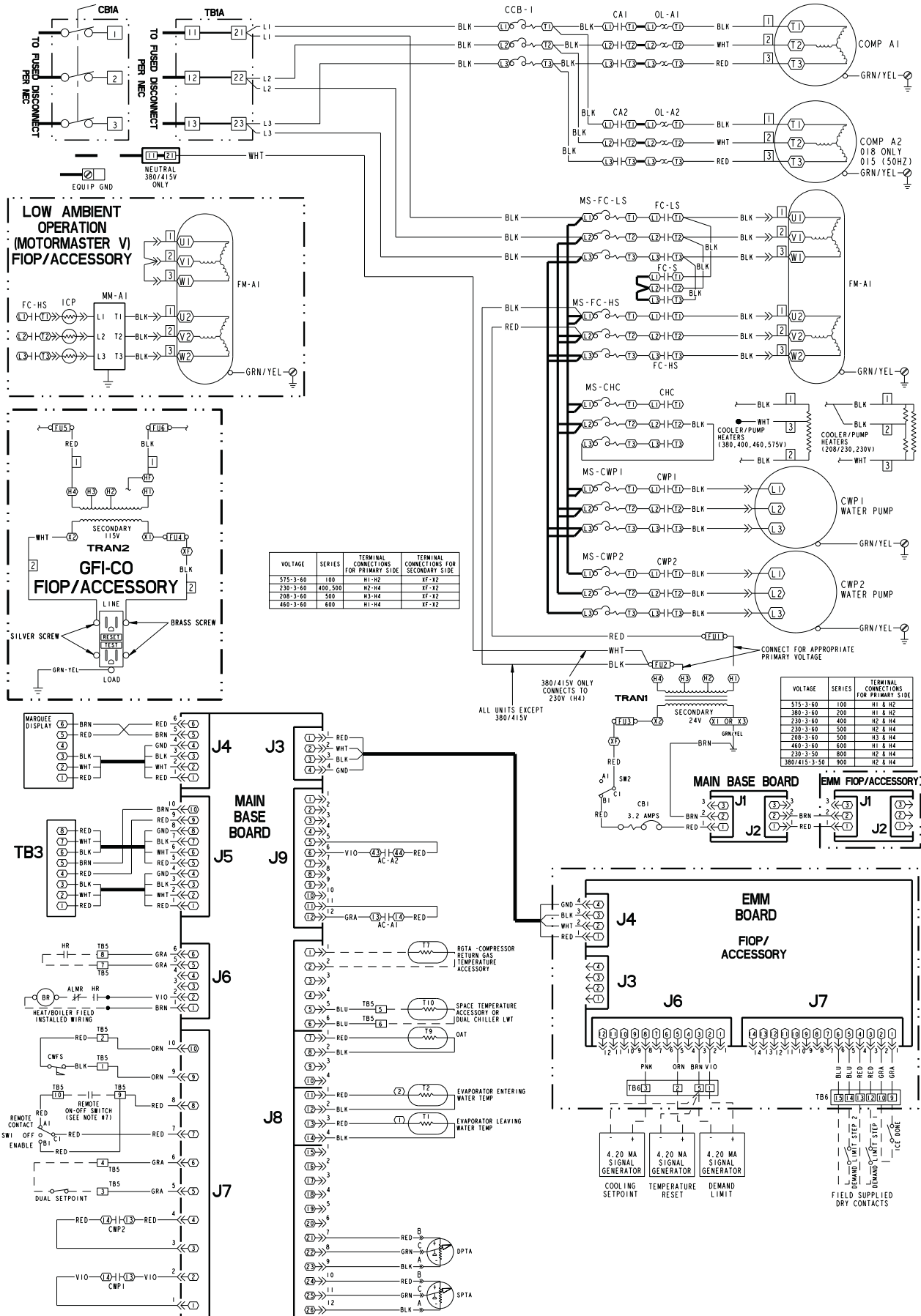


Fig. 3 — Wiring Schematic 30RA010-018

AQUA-SNAP LOW VOLTAGE CONTROL SCHEMATIC (010-018)

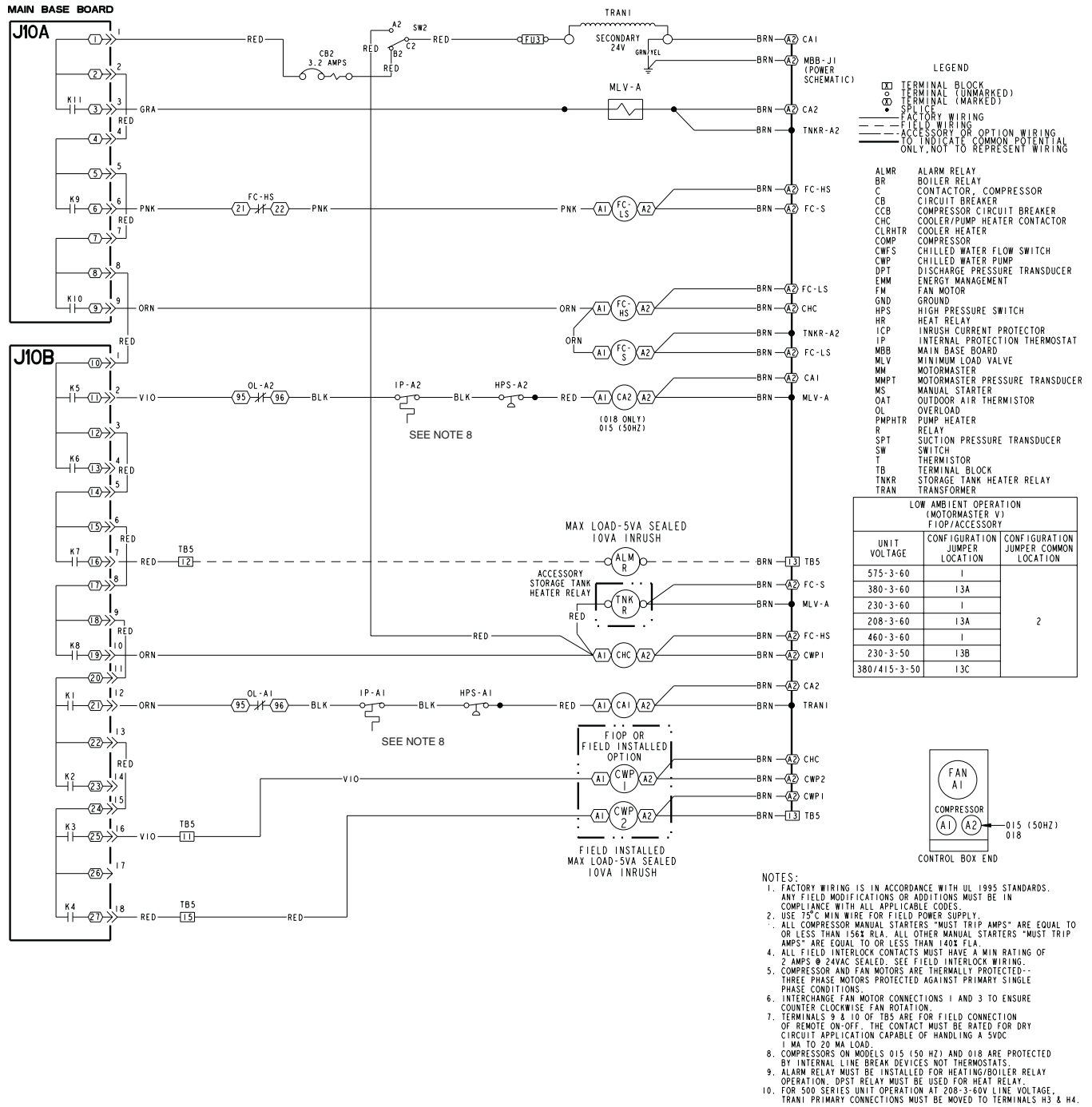
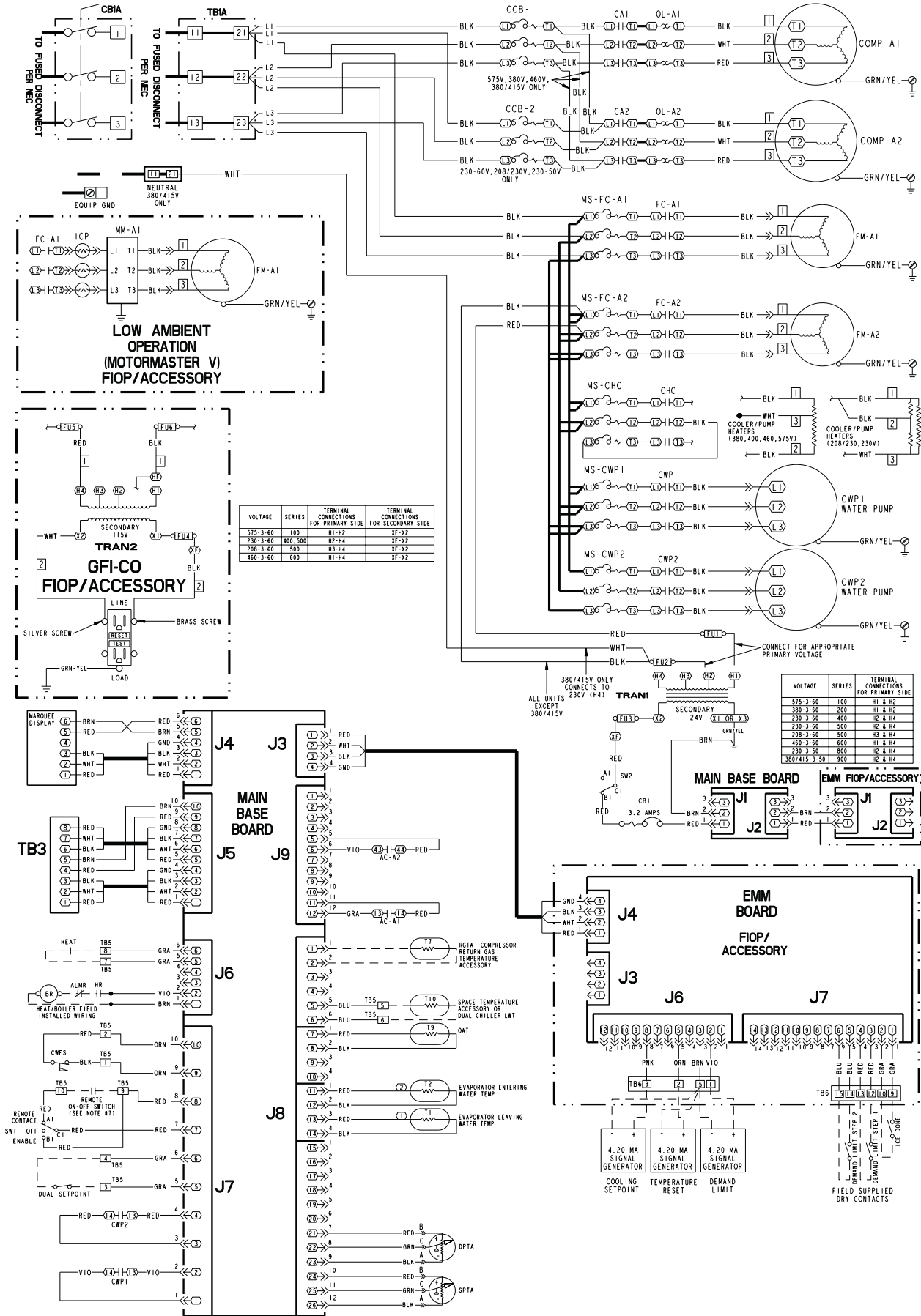


Fig. 3 — Wiring Schematic 30RA010-018 (cont)

30RA022-030 AQUA SNAP

UNIT POWER DISCONNECT OPTION
STANDARD UNIT ALL MODELS



VOLTAGE	SERIES	TERMINAL CONNECTIONS FOR PRIMARY SIDE	TERMINAL CONNECTIONS FOR SECONDARY SIDE
575-3-60	100	H1-H2	XF-X2
230-3-60	400, 500	H2-H4	XF-X2
208-3-60	500	H3-H4	XF-X2
460-3-60	600	H1-H4	XF-X2

VOLTAGE	SERIES	TERMINAL CONNECTIONS FOR PRIMARY SIDE
575-3-60	100	H1 & H2
380-3-60	200	H1 & H2
230-3-60	400	H2 & H4
230-3-60	500	H2 & H4
208-3-60	500	H3 & H4
460-3-60	600	H1 & H4
230-3-50	800	H2 & H4
380/415-3-50	900	H2 & H4

Fig. 4 — Wiring Schematic 30RA022-030

AQUA-SNAP LOW VOLTAGE CONTROL SCHEMATIC (022-030)

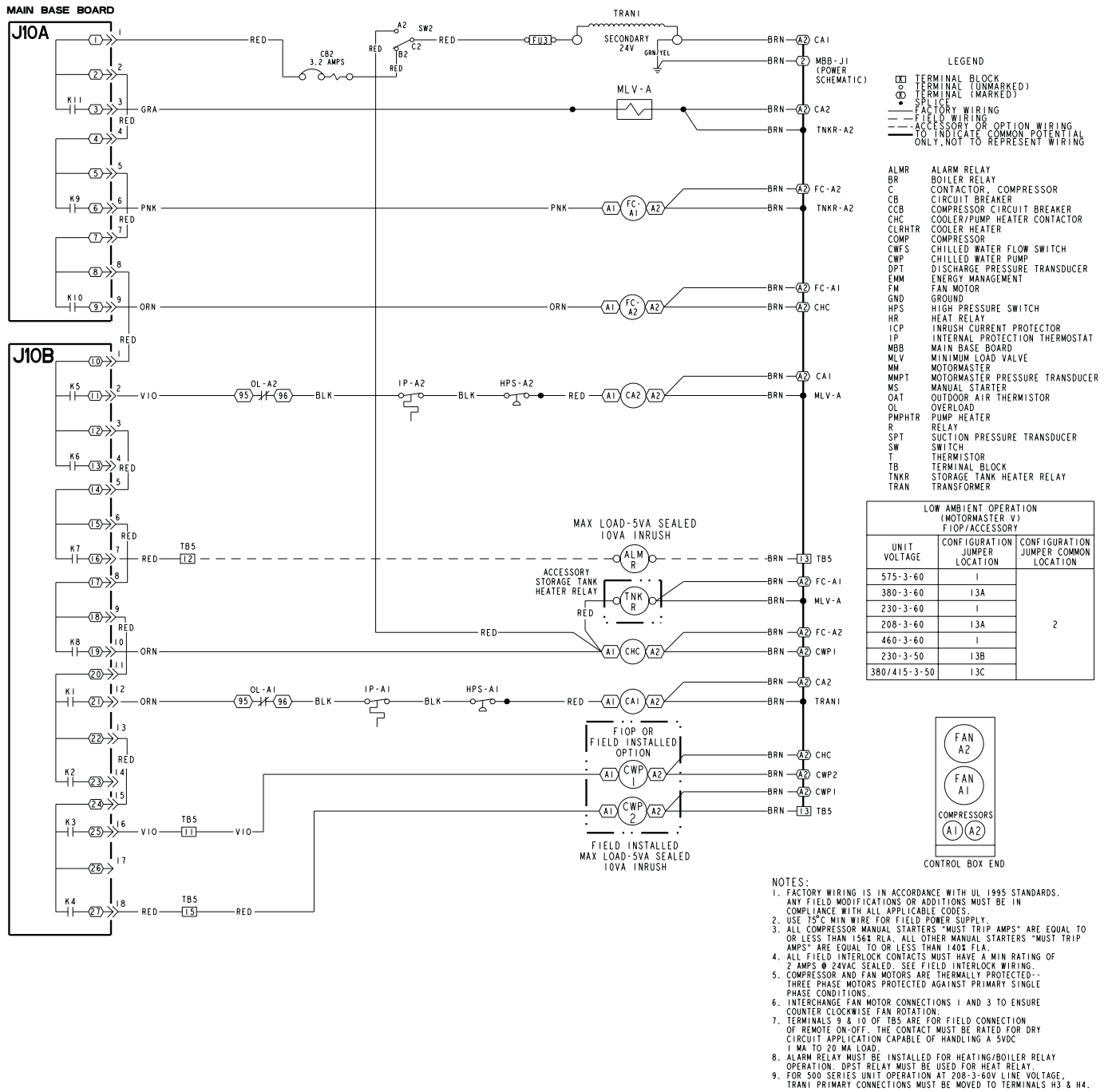


Fig. 4 — Wiring Schematic 30RA022-030 (cont)

30RA032-040 AQUA SNAP

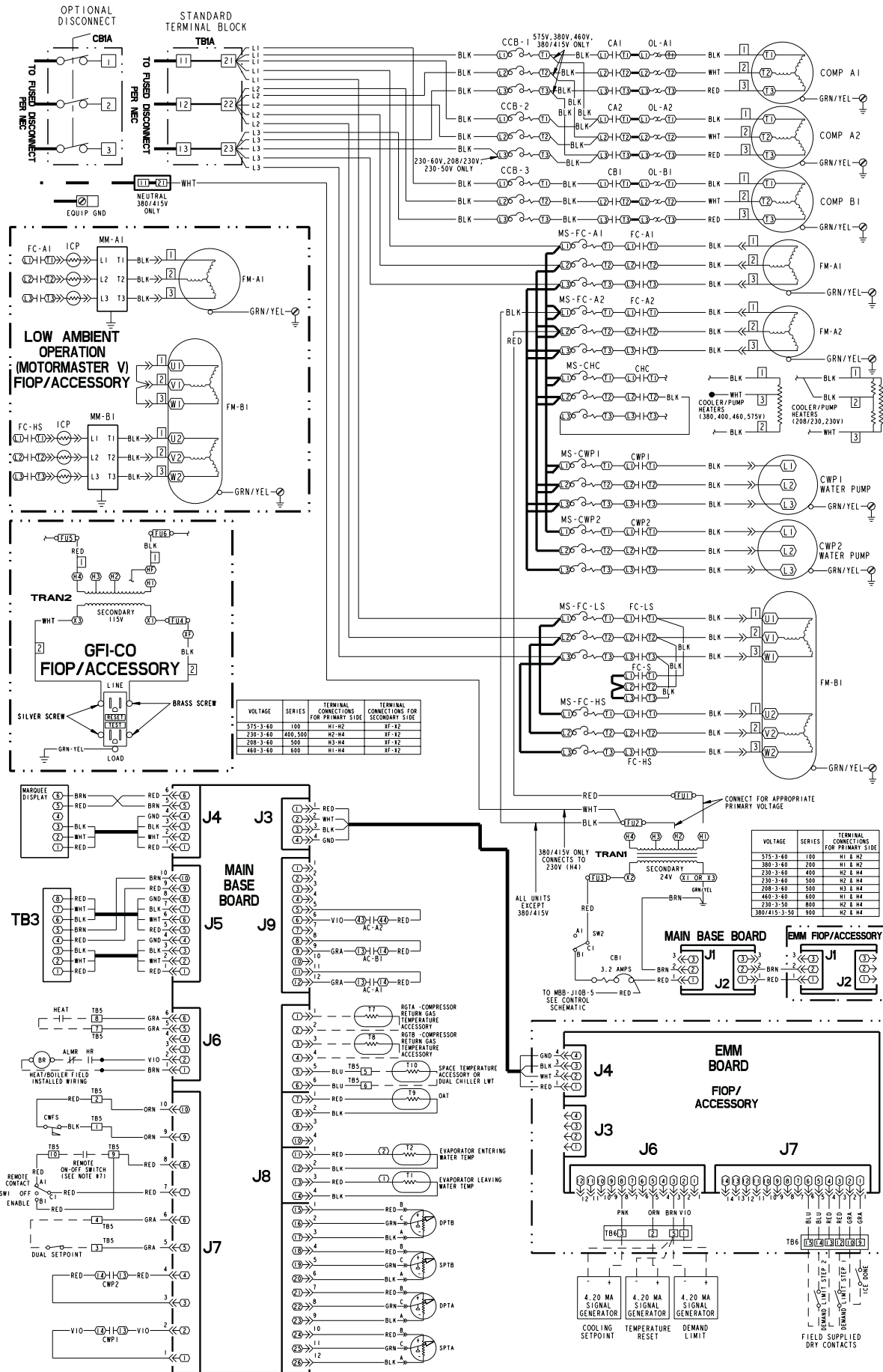
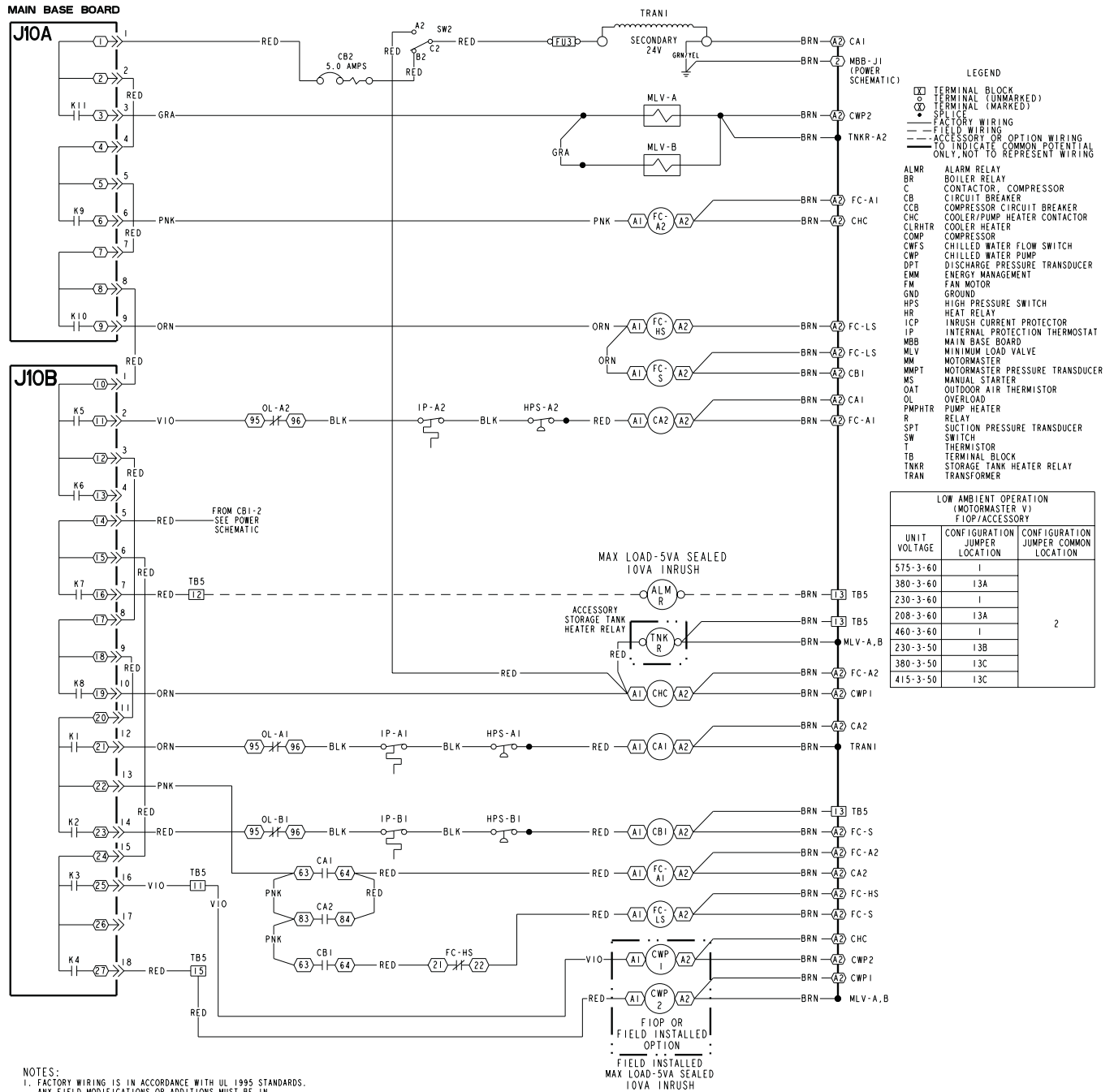


Fig. 5 — Wiring Schematic 30RA032-040

AQUA-SNAP LOW VOLTAGE CONTROL SCHEMATIC (032-040)



- NOTES:**
1. FACTORY WIRING IS IN ACCORDANCE WITH UL 1995 STANDARDS. ANY FIELD MODIFICATIONS OR ADDITIONS MUST BE IN COMPLIANCE WITH ALL APPLICABLE CODES.
 2. USE 15°C MIN WIRE FOR FIELD POWER SUPPLY.
 3. ALL COMPRESSOR MANUAL STARTERS "MUST TRIP AMPS" ARE EQUAL TO OR LESS THAN 156% RLA. ALL OTHER MANUAL STARTERS "MUST TRIP AMPS" ARE EQUAL TO OR LESS THAN 140% FLA.
 4. ALL FIELD INTERLOCK CONTACTS MUST HAVE A MIN RATING OF 2 AMPS @ 24VAC SEALED. SEE FIELD INTERLOCK WIRING.
 5. COMPRESSOR AND FAN MOTORS ARE THERMALLY PROTECTED-- THREE PHASE MOTORS PROTECTED AGAINST PRIMARY SINGLE PHASE CONDITIONS.
 6. INTERCHANGE FAN MOTOR CONNECTIONS 1 AND 3 TO ENSURE COUNTER CLOCKWISE FAN ROTATION.
 7. TERMINALS 9 & 10 OF TB5 ARE FOR FIELD CONNECTION OF REMOTE ON-OFF. THE CONTACT MUST BE RATED FOR DRY CIRCUIT APPLICATION CAPABLE OF HANDLING A 5VDC 1 MA TO 20 MA LOAD.
 8. ALARM RELAY MUST BE INSTALLED FOR HEATING/BOILER RELAY OPERATION. DPST RELAY MUST BE USED FOR HEAT RELAY.
 9. FOR 500 SERIES UNIT OPERATION AT 208-3-60V LINE VOLTAGE, TRAN1 PRIMARY CONNECTIONS MUST BE MOVED TO TERMINALS H3 & H4.

Fig. 5 — Wiring Schematic 30RA032-040 (cont)

30RA042-055 AQUA SNAP

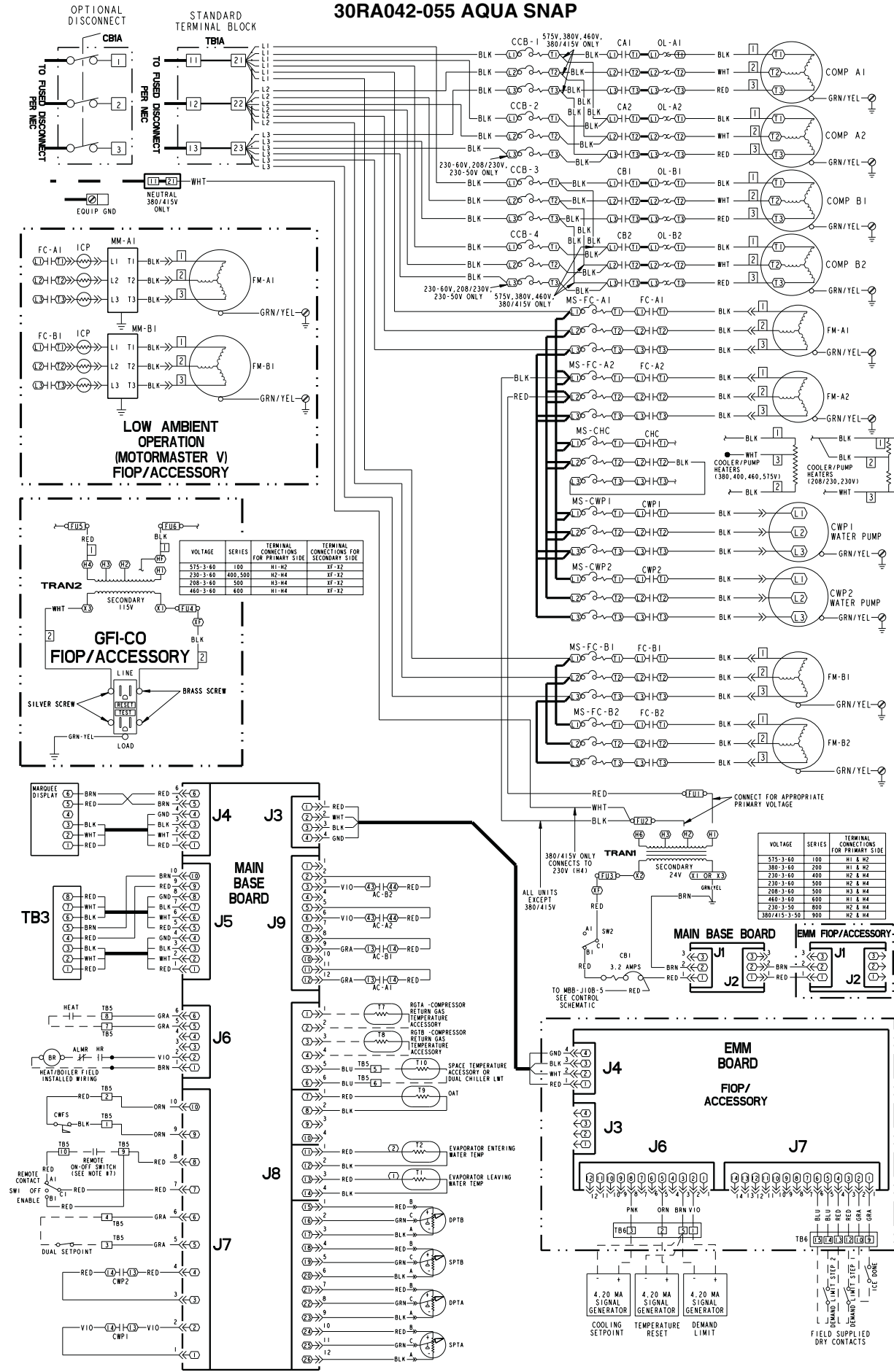
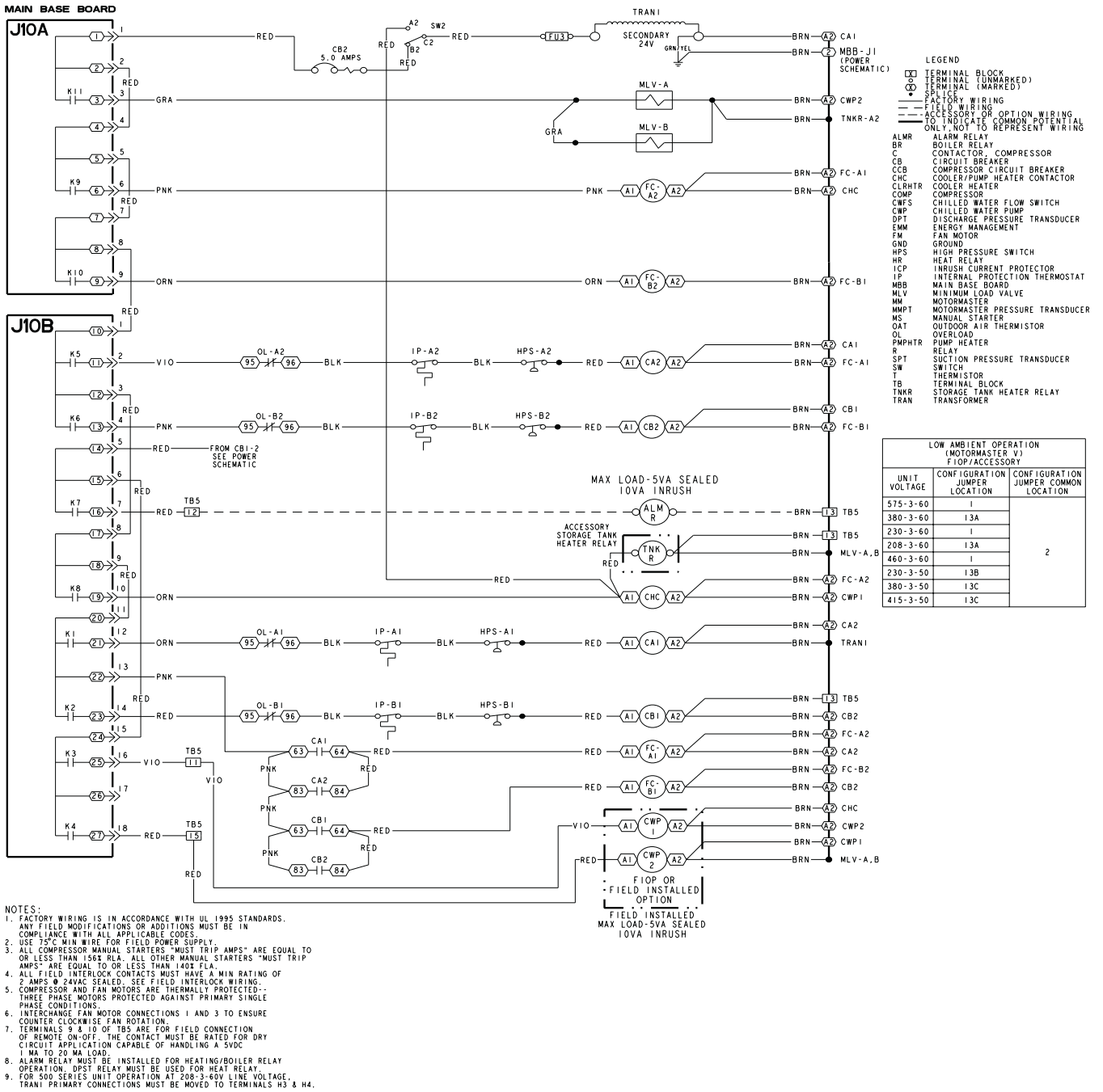


Fig. 6 — Wiring Schematic 30RA042-055

AQUA-SNAP LOW VOLTAGE CONTROL SCHEMATIC (042-055)



- LEGEND**
- TERMINAL BLOCK
 - TERMINAL (UNMARKED)
 - TERMINAL (MARKED)
 - FACTORY WIRING
 - - - FIELD WIRING
 - · - ACCESSORY OR OPTION WIRING TO INDICATE COMMON POTENTIAL ONLY; NOT TO REPRESENT WIRING
- ALMR ALARM RELAY
 - BR BOILER RELAY
 - C CONTACTOR, COMPRESSOR
 - CB CIRCUIT BREAKER
 - CCB COMPRESSOR CIRCUIT BREAKER
 - CHC COOLER/PUMP HEATER CONTACTOR
 - CLR/HR COOLER HEATER COMPRESSOR
 - CWF CHILLED WATER FLOW SWITCH
 - CWP CHILLED WATER PUMP
 - DPT DISCHARGE PRESSURE TRANSDUCER
 - EMM ENERGY MANAGEMENT
 - FM FAN MOTOR
 - GND GROUND
 - HPS HIGH PRESSURE SWITCH
 - HR HEAT RELAY
 - ICP INRUSH CURRENT PROTECTOR
 - IP INTERNAL PROTECTION THERMOSTAT
 - MBB MAIN BASE BOARD
 - MLV MINIMUM LOAD VALVE
 - MM MOTORMASTER
 - MMPPT MOTORMASTER PRESSURE TRANSDUCER
 - MS MANUAL STARTER
 - OAT OUTDOOR AIR THERMISTOR
 - OL OVERLOAD
 - PMPHTR PUMP HEATER RELAY
 - R RELAY
 - SPT SUCTION PRESSURE TRANSDUCER
 - SW SWITCH
 - T THERMISTOR
 - TB TERMINAL BLOCK
 - TNR STORAGE TANK HEATER RELAY
 - TRAN TRANSFORMER

LOW AMBIENT OPERATION (MOTORMASTER V) FIOP/ACCESSORY		
UNIT VOLTAGE	CONFIGURATION JUMPER LOCATION	CONFIGURATION JUMPER COMMON LOCATION
575-3-60	I	2
380-3-60	13A	
230-3-60	I	
208-3-60	13A	
460-3-60	I	
230-3-50	13B	
380-3-50	13C	
415-3-50	13C	

- NOTES:**
1. FACTORY WIRING IS IN ACCORDANCE WITH UL 1995 STANDARDS. ANY FIELD MODIFICATIONS OR ADDITIONS MUST BE IN COMPLIANCE WITH ALL APPLICABLE CODES.
 2. USE 75°C MIN WIRE FOR FIELD POWER SUPPLY.
 3. ALL COMPRESSOR MANUAL STARTERS "MUST TRIP" AMPs OR LESS THAN 156A BKA. ALL OTHER MANUAL STARTERS "MUST TRIP" AMPs ARE EQUAL TO OR LESS THAN 140A FLA.
 4. ALL FIELD INTERLOCK CONTACTS MUST HAVE A MIN RATING OF 2 AMPs @ 24VAC SEALED. SEE FIELD INTERLOCK WIRING.
 5. COMPRESSOR AND FAN MOTORS ARE THERMALLY PROTECTED--THREE PHASE MOTORS PROTECTED AGAINST PRIMARY SINGLE PHASE CONDITIONS.
 6. INTERCHANGE FAN MOTOR CONNECTIONS 1 AND 3 TO ENSURE COUNTER CLOCKWISE FAN ROTATION.
 7. TERMINALS 8 & 10 OF TB5 ARE FOR FIELD CONNECTION OF REMOTE ON-OFF. THE CONTACT MUST BE RATED FOR DRY CIRCUIT APPLICATION CAPABLE OF HANDLING A 5VDC 1 MA TO 20 MA LOAD.
 8. ALARM RELAY MUST BE INSTALLED FOR HEATING/BOILER RELAY OPERATION. DPST RELAY MUST BE USED FOR HEAT RELAY.
 9. FOR 500 SERIES UNIT OPERATION AT 208-3-60V LINE VOLTAGE, TRAN1 PRIMARY CONNECTIONS MUST BE MOVED TO TERMINALS H3 & H4.

Fig. 6 — Wiring Schematic 30RA042-055 (cont)

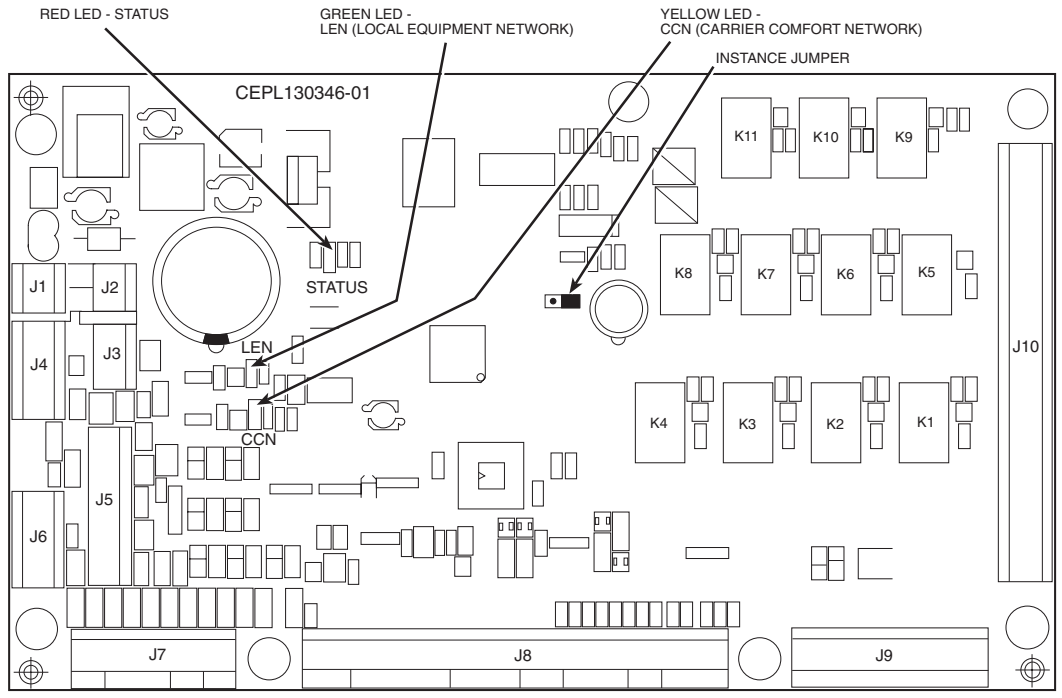


Fig. 7 — Main Base Board

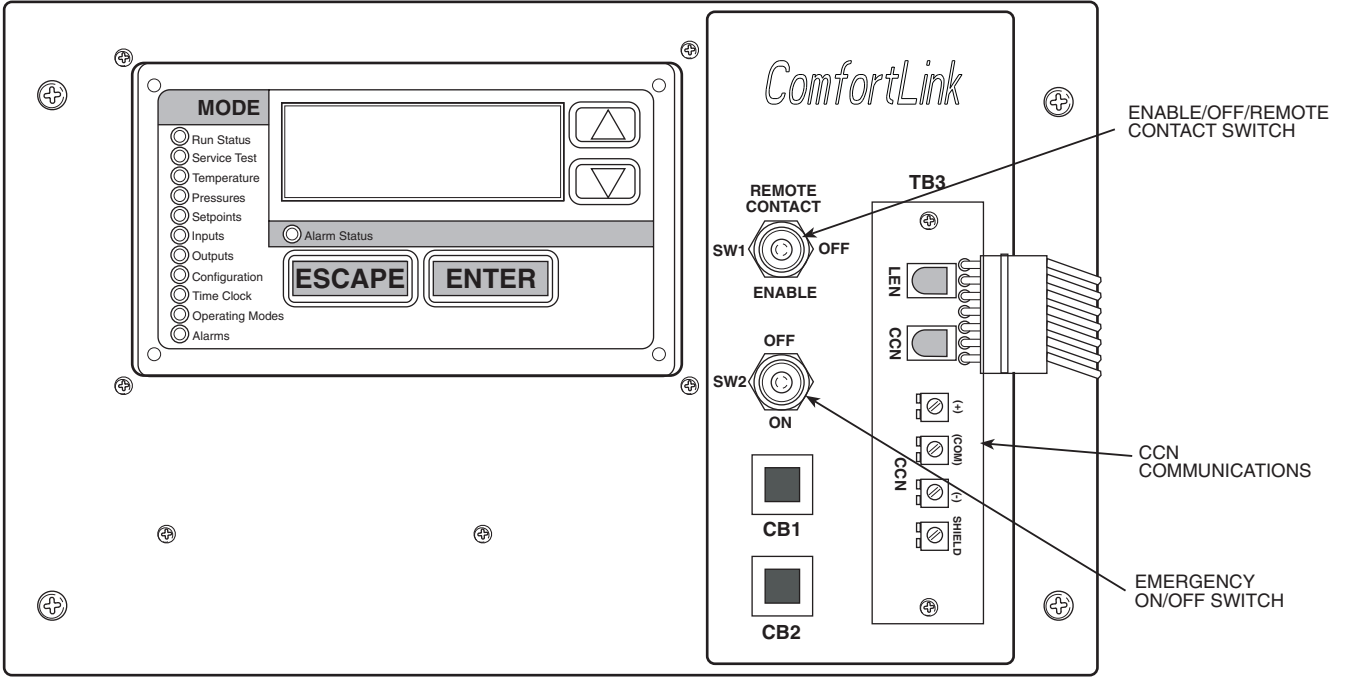


Fig. 8 — LEN/CCN Interface, Enable/Off/Remote Contact Switch, and Emergency On/Off Switch Locations

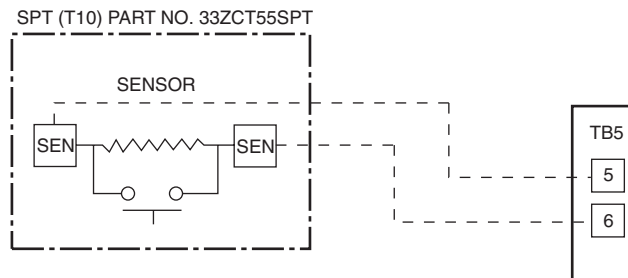


Fig. 9 — Typical Space Temperature Sensor Wiring

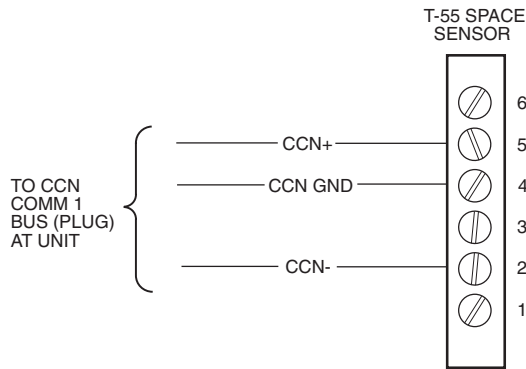


Fig. 10 — CCN Communications Bus Wiring to Optional Space Sensor RJ11 Connector

Energy Management Module (Fig. 11) — This factory-installed option (FIOP) or field-installed accessory is used for the following types of temperature reset, demand limit, and/or ice features:

- 4 to 20 mA leaving fluid temperature reset (requires field-supplied 4 to 20 mA generator)
- 4 to 20 mA cooling set point reset (requires field-supplied 4 to 20 mA generator)
- Discrete inputs for 2-step demand limit (requires field-supplied dry contacts capable of handling a 24 vac, 50 mA load)
- 4 to 20 mA demand limit (requires field-supplied 4 to 20 mA generator)
- Discrete input for Ice Done switch (requires field-supplied dry contacts capable of handling a 24 vac, 50 mA load)

See Demand Limit and Temperature Reset sections on pages 44 and 43 for further details.

CAUTION

Care should be taken when interfacing with other manufacturer's control systems due to possible power supply differences, full wave bridge versus half wave rectification. The two different power supplies cannot be mixed. *ComfortLink™* controls use half wave rectification. A signal isolation device should be utilized if a full wave bridge signal generating device is used.

Loss-of-Cooler Flow Protection — A proof-of-cooler flow device is factory installed in all chillers. It is recommended that proper operation of the switch be verified on a regular basis.

Thermostatic Expansion Valves (TXV) — All units are equipped from the factory with conventional TXVs. Each

refrigeration circuit is also supplied with a factory-installed liquid line filter drier and sight glass.

The TXV is set at the factory to maintain approximately 8 to 12° F (4.4 to 6.7° C) suction superheat leaving the cooler by metering the proper amount of refrigerant into the cooler. All TXVs are adjustable, *but should not be adjusted unless absolutely necessary.*

The TXV is designed to limit the cooler saturated suction temperature to 55 F (12.8 C). This makes it possible for unit to start at high cooler fluid temperatures without overloading the compressor.

Capacity Control — The control system cycles compressors, and minimum load valve solenoids (if equipped) to maintain the user-configured leaving chilled fluid temperature set point. Entering fluid temperature is used by the Main Base Board (MBB) to determine the temperature drop across the cooler and is used in determining the optimum time to add or subtract capacity stages. The chilled fluid temperature set point can be automatically reset by the return fluid temperature, space, or outdoor-air temperature reset features. It can also be reset from an external 4 to 20-mA signal (requires Energy Management Module FIOP or accessory).

The control has an automatic lead-lag feature built in which determines the wear factor (combination of starts and run hours) for each compressor. If all compressors are off and less than 30 minutes has elapsed since the last compressor was turned off, the wear factor is used to determine which compressor to start next. If no compressors have been running for more than 30 minutes and the leaving fluid temperature is greater than the saturated condensing temperature, the wear factor is still used to determine which compressor to start next. If the leaving fluid temperature is less than the saturated condensing temperature, then the control will start either compressor A1 or compressor B1 first, depending on the user-configurable circuit lead-lag value.

The TXVs will provide a controlled start-up. During start-up, the low pressure logic will be bypassed for 2½ minutes to allow for the transient changes during start-up. As additional stages of compression are required, the processor control will add them. See Table 6 and 7.

If a circuit is to be stopped, the compressor with the lowest wear factor will be shut off first in most cases. Certain override conditions may shut off the smaller of two compressors on a circuit first.

The capacity control algorithm runs every 30 seconds. The algorithm attempts to maintain the Control Point at the desired set point. Each time it runs, the control reads the entering and leaving fluid temperatures. The control determines the rate at which conditions are changing and calculates 2 variables based on these conditions. Next, a capacity ratio is calculated using the 2 variables to determine whether or not to make any changes to the current stages of capacity. This ratio value ranges from -100 to +100%. If the next stage of capacity is a compressor, the control starts (stops) a compressor when the ratio reaches +100% (-100%). If installed, the minimum load valve solenoid will be energized with the first stage of capacity. Minimum load valve value is a fixed 30% in the total capacity calculation. The control will also use the minimum load valve solenoid as the last stage of capacity before turning off the last compressor. If the close control feature (CLS.C) [Configuration, OPT2] is enabled the control will use the minimum load valve solenoid whenever possible to fine tune leaving fluid temperature control. A delay of 90 seconds occurs after each capacity step change. Refer to Tables 6 and 7.

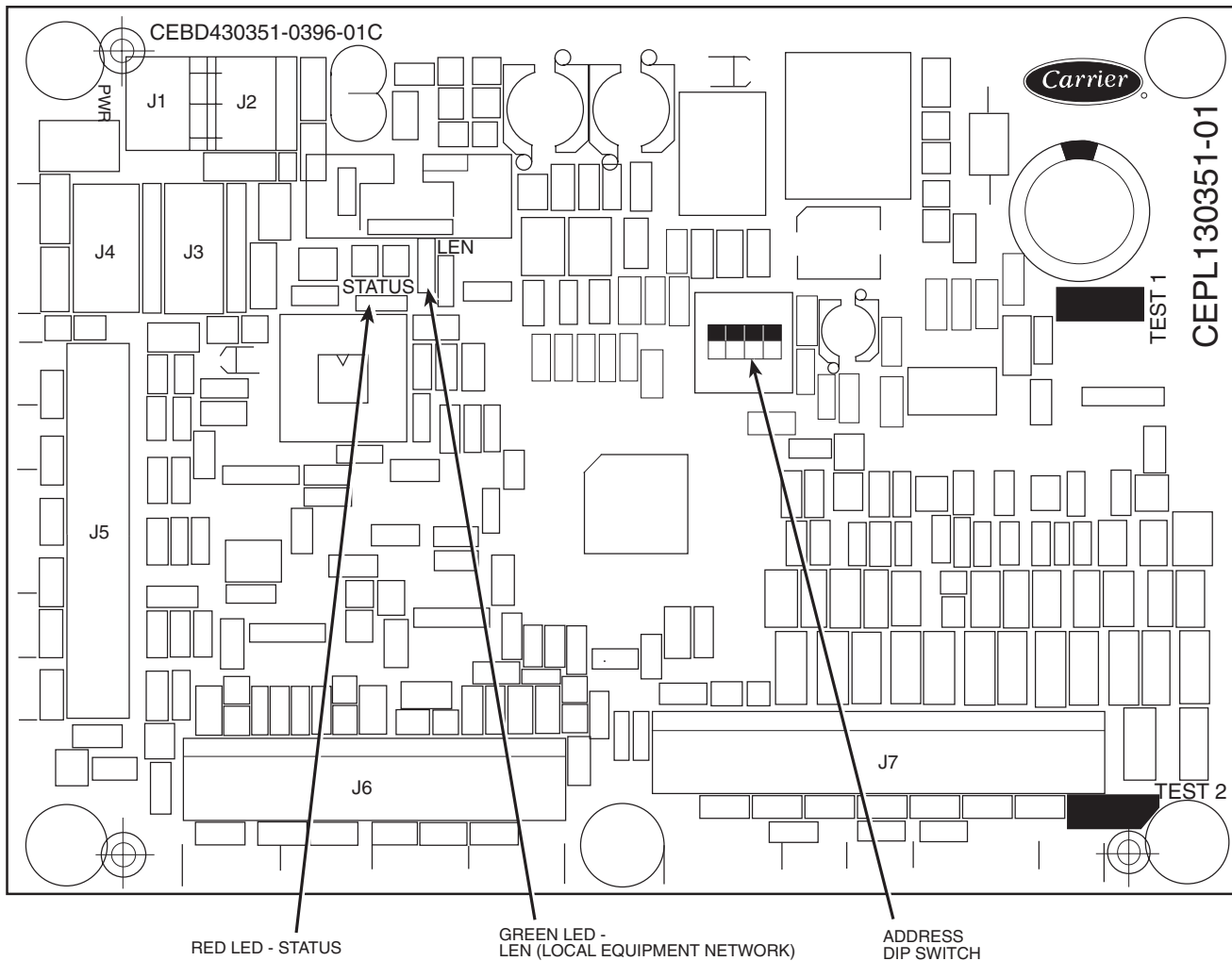


Fig. 11 — Energy Management Module

Table 6 — Part Load Data Percent Displacement, Standard Units without Minimum Load Valve

30RA UNIT SIZE	CONTROL STEPS	LOADING SEQ A		LOADING SEQ B	
		% Displacement	Compressor	% Displacement	Compressor
010,015 (60 Hz)	1	100	A1	—	—
015 (50 Hz), 018	1	50	A1	—	—
	2	100	A1,A2	—	—
022 (60 Hz)	1	42	A1	—	—
	2	100	A1, A2	—	—
022 (50 Hz), 025, 030	1	50	A1	—	—
	2	100	A1,A2	—	—
032, 035 (60 Hz)	1	25	A1	40	B1
	2	60	A1,A2	65	A1,B1
	3	100	A1,A2,B1	100	A1,A2,B1
035 (50 Hz)	1	33	A1	33	B1
	2	67	A1, A2	67	A1, B1
	3	100	A1, A2, B1	100	A1, A2, B1
040	1	32	A1	37	B1
	2	63	A1, A2	68	A1, B1
	3	100	A1, A2, B1	100	A1, A2, B1
042, 045 (50 Hz), 050, 055	1	25	A1	25	B1
	2	50	A1,B1	50	A1,B1
	3	75	A1,A2,B1	75	A1,B1,B2
	4	100	A1,A2,B1,B2	100	A1,A2,B1,B2
045 (60 Hz)	1	22	A1	22	B1
	2	44	A1,B1	44	A1,B1
	3	72	A1,A2,B1	72	A1,B1,B2
	4	100	A1,A2,B1,B2	100	A1,A2,B1,B2

NOTE: These capacity steps may vary due to different capacity staging sequences.

Table 7 — Part Load Data Percent Displacement, Standard Units with Minimum Load Valve

30RA UNIT SIZE	CONTROL STEPS	LOADING SEQ A		LOADING SEQ B	
		% Displacement	Compressor	% Displacement	Compressor
010 (50/60 Hz)	1	69/ 71	A1*	—	—
	2	100/100	A1	—	—
015 (60 Hz)	1	79	A1*	—	—
	2	100	A1	—	—
015 (50 Hz)	1	28	A1*	—	—
	2	50	A1	—	—
	3	100	A1,A2	—	—
018 (50/60 Hz)	1	32/ 31	A1*	—	—
	2	50/ 50	A1	—	—
	3	100/100	A1,A2	—	—
022 (50/60 Hz)	1	27/ 35	A1*	—	—
	2	42/ 50	A1	—	—
	3	100/100	A1,A2	—	—
025 (50/60 Hz)	1	38/ 37	A1*	—	—
	2	50/ 50	A1	—	—
	3	100/100	A1,A2	—	—
030	1	39	A1*	—	—
	2	50	A1	—	—
	3	100	A1,A2	—	—
032	1	15	A1*	30	B1*
	2	25	A1	40	B1
	3	60	A1,A2	65	A1,B1
	4	100	A1,A2,B1	100	A1,A2,B1
035 (50/60 Hz)	1	16/25	A1*	32/25	B1*
	2	25/33	A1	40/33	B1
	3	60/67	A1,A2	65/67	A1,B1
	4	100	A1,A2,B1	100	A1,A2,B1
040	1	24	A1*	29	B1*
	2	32	A1	37	B1
	3	63	A1,A2	68	A1,B1
	4	100	A1,A2,B1	100	A1,A2,B1
042	1	18	A1*	18	B1*
	2	25	A1	25	B1
	3	50	A1,B1	50	A1,B1
	4	75	A1,A2,B1	75	A1,B1,B2
	5	100	A1,A2,B1,B2	100	A1,A2,B1,B2
045 (60 Hz)	1	15	A1*	15	B1*
	2	22	A1	22	B1
	3	44	A1,B1	44	A1,B1
	4	72	A1,A2,B1	72	A1,B1,B2
	5	100	A1,A2,B1,B2	100	A1,A2,B1,B2
045 (50 Hz), 050	1	19	A1*	19	B1*
	2	25	A1	25	B1
	3	50	A1,B1	50	A1,B1
	4	77	A1,A2,B1	77	A1,B1,B2
	5	100	A1,A2,B1,B2	100	A1,A2,B1,B2
055	1	20	A1*	20	B1*
	2	25	A1	25	B1
	3	50	A1,B1	50	A1,B1
	4	75	A1,A2,B1	75	A1,B1,B2
	5	100	A1,A2,B1,B2	100	A1,A2,B1,B2

*Minimum Load Valve energized.

NOTE: These capacity steps may vary due to different capacity staging sequences.

MINUTES LEFT FOR START — This value is displayed only in the network display tables (using Service Tool, ComfortVIEW™ or ComfortWORKS® software) and represents the amount of time to elapse before the unit will start its initialization routine. This value can be zero without the machine running in many situations. This can include being unoccupied, ENABLE/OFF/REMOTE CONTACT switch in the OFF position, CCN not allowing unit to start, Demand Limit in effect, no call for cooling due to no load, and alarm or alert conditions present. If the machine should be running and none of the above are true, a minimum off time (DELY, see below) may be in effect. The machine should start normally once the time limit has expired.

MINUTES OFF TIME (DELY) [Configuration OPT2] — This user-configurable time period is used by the control to determine how long unit operation is delayed after power is applied/restored to the unit. Typically, this time period is configured when multiple machines are located on a single site. For example, this gives the user the ability to prevent all the units from restarting at once after a power failure. A value of zero for this variable does not mean that the unit should be running.

LEAD/LAG DETERMINATION — This is a configurable choice and is factory set to be automatic for all units. The value can be changed to Circuit A or Circuit B leading as desired. Set at automatic, the control will sum the current number of logged circuit starts and one-quarter of the current operating hours for each circuit. The circuit with the lowest sum is started first. Changes to which circuit is the lead circuit and which is the lag are also made when total machine capacity is at 100% or when there is a change in the direction of capacity (increase or decrease) and each circuit's capacity is equal.

CAPACITY CONTROL OVERRIDES — The following overrides will modify the normal operation of the routine.

Deadband Multiplier — The user configurable Deadband Multiplier (Z.GN) [Configuration, SLCT] has a default value of 1.0. The range is from 1.0 to 4.0. When set to other than 1.0, this factor is applied to the capacity Load/Unload Factor. The larger this value is set, the longer the control will delay between adding or removing stages of capacity. Figure 12 shows how compressor starts can be reduced over time if the leaving water temperature is allowed to drift a larger amount above and below the set point. This value should be set in the range of 3.0 to 4.0 for systems with small loop volumes.

First Stage Override — If the current capacity stage is zero, the control will modify the routine with a 1.2 factor on adding the first stage to reduce cycling. This factor is also applied when the control is attempting to remove the last stage of capacity.

Slow Change Override — The control prevents the capacity stages from being changed when the leaving fluid temperature is close to the set point (within an adjustable deadband) and moving towards the set point.

Ramp Loading (CRMP) [Configuration, SLCT] — Limits the rate of change of leaving fluid temperature. If the unit is in a Cooling mode and configured for Ramp Loading, the control makes 2 comparisons before deciding to change stages of capacity. The control calculates a temperature difference between the control point and leaving fluid temperature. If the difference is greater than 4 °F (2.2 °C) and the rate of change (°F or °C per minute) is more than the configured Cooling Ramp Loading value (CRMP), the control does not allow any changes to the current stage of capacity.

Low Entering Fluid Temperature Unloading — When the entering fluid temperature is below the control point, the control will attempt to remove 25% of the current stages being used. If exactly 25% cannot be removed, the control removes an amount greater than 25% but no more than necessary. The lowest stage will not be removed.

Minimum Load Control — If equipped, the minimum load control valve is energized only when one compressor in the circuit is running. If the close control feature is enabled the minimum load control valve may be used as needed to obtain leaving fluid temperature close to set point.

Cooler Freeze Protection — The control will try to prevent shutting the chiller down on a Cooler Freeze Protection alarm by removing stages of capacity. If the cooler fluid selected is Water, the freeze point is 34 F (1.1 C). If the cooler fluid selected is Brine, the freeze point is the Brine freeze Point (BR.FZ) [Set Points, FRZ]. This alarm condition (A207) only references leaving fluid temperature and NOT Brine Freeze point. If the cooler leaving fluid temperature is less than the freeze point plus 2.0° F (1.1° C), the control will immediately remove one stage of capacity. This can be repeated once every 30 seconds.

Low Saturated Suction Protection — The control will try to prevent shutting a circuit down due to low saturated suction conditions by removing stages of capacity. These circuit alert conditions (T116, T117) compare saturated suction temperature to the configured Brine Freeze point (BR.FZ) [Set Points, FRZ]. The Brine Freeze point is a user-configurable value that must be left at 34 F (1.1 C) for 100% water systems. A lower value may be entered for systems with brine solutions, but this value should be set according to the freeze protection level of the brine mixture. Failure to properly set this brine freeze point value may permanently damage the brazed plate heat exchanger. The control will initiate Mode 7 (Circuit A) or Mode 8 (Circuit B) to indicate a circuit's capacity is limited and that eventually the circuit may shut down.

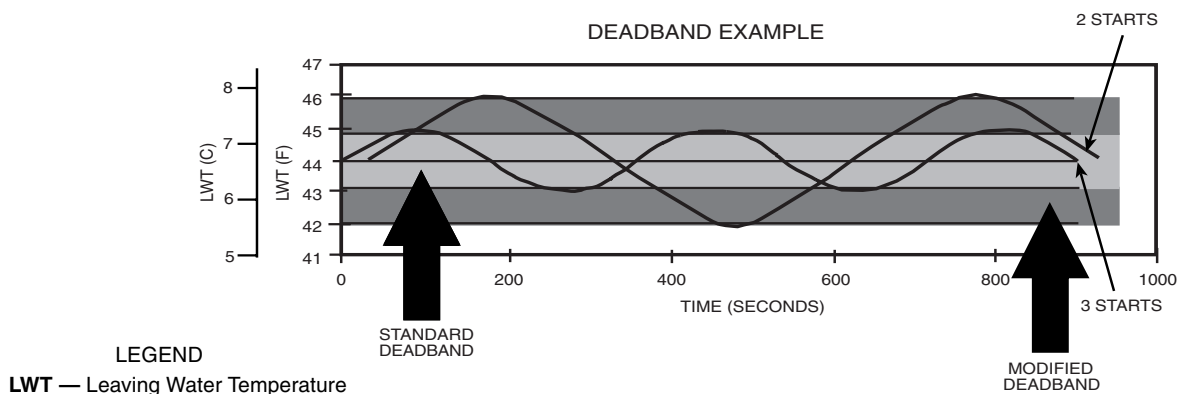
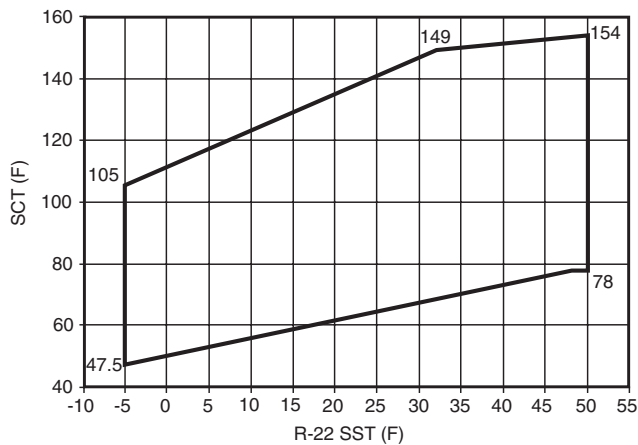


Fig. 12 — Deadband Multiplier

Head Pressure Control — The Main Base Board (MBB) controls the condenser fans to maintain the lowest condensing temperature possible, and thus the highest unit efficiency. The MBB uses the saturated condensing temperature input from the discharge pressure transducer to control the fans. Head pressure control is maintained through a calculated set point which is automatically adjusted based on actual



LEGEND

SCT — Saturated Condensing Temperature
 SST — Saturated Suction Temperature

Fig. 13 — Operating Envelope for R-22 Maneurop Compressor

saturated condensing and saturated suction temperatures so that the compressor(s) is (are) always operating within the manufacturer's specified envelope (see Fig. 13). The control will automatically reduce the unit capacity as the saturated condensing temperature approaches an upper limit. The control will indicate through an alert that a high ambient unloading mode is in effect. If the saturated condensing temperature in a circuit exceeds the calculated maximum, the circuit will be stopped. For these reasons, there are no head pressure control methods or set points to enter. If the saturated condensing temperature in a circuit is greater than or equal to 95 F (35 C) at start-up, all available condenser fans will be started to prevent excessive discharge pressure during pull-down. The control will turn off a fan stage when the condensing temperature has been below the calculated head pressure set point by 35 F (19.4 C) for more than 2 minutes. Fan sequences are shown in Fig. 14.

MOTORMASTER® V OPTION — For low-ambient operation, the lead fan on a circuit can be equipped with the Motormaster V head pressure controller option or accessory. The control will automatically raise the head pressure set point by 5 F (2.8 C) when Motormaster control is configured. The controller is energized with the first fan stage and adjusts fan speed to maintain a liquid pressure of 135 psig (931 kPa). For sizes 010-018 and Circuit B of sizes 032-040, the two-speed fan is wired for high speed operation and the Motormaster V controller adjusts fan speed. For size 022-030, 042-055 and circuit A of the 032-040 sizes, the lead fan (A1 or B1) in the circuit is controlled. Refer to Fig. 14 for condenser fan staging information. Refer to Fig. 15 for typical pressure transducer location.



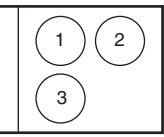
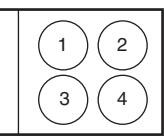
FAN ARRANGEMENT	FAN NO.	FAN RELAY	NORMAL CONTROL
30RAN010-018 CONTROL BOX END 	1	FC-LS	Energize Fan at Low Speed
	1	FC-HS	Energize Fan at High Speed
30RAN022-030 CONTROL BOX END 	1	FC-A1	First Stage Condenser Fan
	2	FC-A2	Second Stage Condenser Fan
30RAN032-040 CONTROL BOX END 	1	FC-A1	On with Compressor A1 and/or Compressor A2
	2	FC-A2	First Stage Condenser Fan, Circuit A
	3	FC-LS	Low Speed, Fan on w/Compressor B1
	3	FC-HS	Energize Fan at High Speed, Circuit B
30RAN042-055 CONTROL BOX END 	1	FC-A1	On with Compressor A1 and/or Compressor A2
	2	FC-A2	First Stage Condenser Fan, Circuit A
	3	FC-B1	On with Compressor B1 and/or Compressor B2
	4	FC-B2	First Stage Condenser Fan, Circuit B

Fig. 14 — 30RA Condenser Fan Sequence

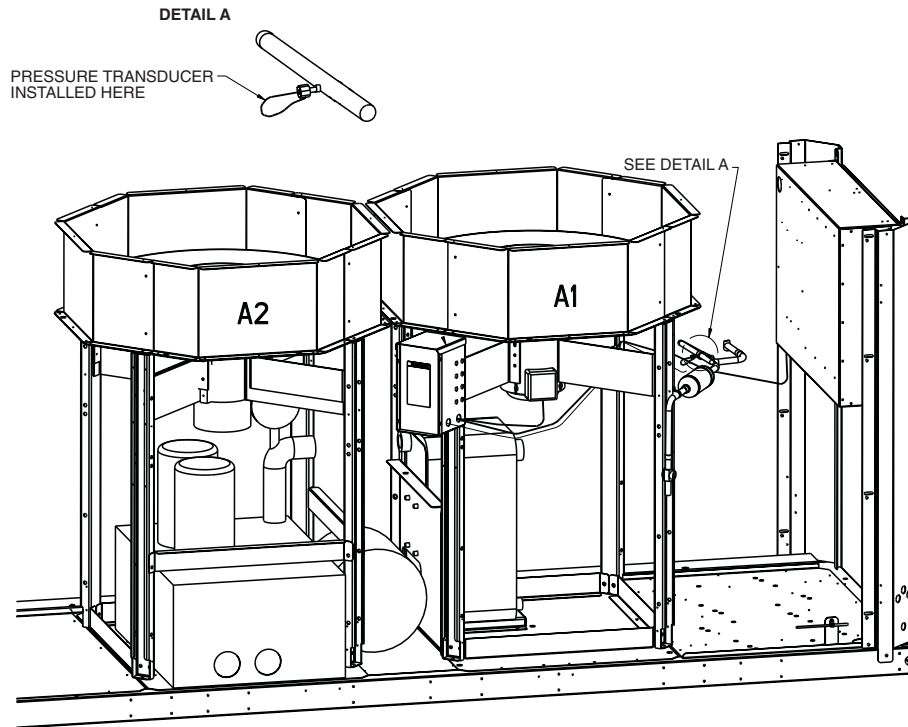


Fig. 15 — Typical Motormaster® V Controller and Pressure Transducer Location (Sizes 022-030 Shown)

Operation of Machine Based on Control Method and Cooling Set Point Selection Settings

Machine On/Off control is determined by the configuration of the control method (CTRL) [Configuration, OPT2] and cooling set point select (CLSP) [Configuration, SLCT] variables. All models are factory configured with cooling set point select set to 1 (single set point, CSP1). With the control method set to 0, simply switching the Enable/Off/Remote Contact switch to the Enable or Remote Contact position (external contacts closed) will put the chiller in an occupied state. The control mode [Operating Modes, MODE] will be 1 (OFF LOCAL) when the switch is Off and will be 5 (ON LOCAL) when in the Enable position or Remote Contact position with external contacts closed.

Two other control methods are available for Machine On/Off control:

OCCUPANCY SCHEDULE (CTRL=2) — The Main Base Board will use the operating schedules as defined under the Time Clock mode in the Marquee display. These schedules are identical. The schedule number must be set to 1 for local schedule.

The schedule number can be set anywhere from 65 to 99 for operation under a CCN global schedule. The Enable/Off/Remote Contact must be in the Enable or Remote Contact position. The control mode [Operating Modes, MODE] will be 1 when the switch is Off. The control mode will be 3 when the Enable/Off/Remote Contact switch input is On and the time of day is during an unoccupied period. Similarly, the control mode will be 7 when the time of day is during an occupied period.

CCN SCHEDULE (CTRL=3) — An external CCN device such as Flotronic™ System Manager controls the On/Off state of the machine. This CCN device forces the variable 'CHIL_S_S' between Start/Stop to control the chiller. The control mode [Operating Modes, MODE] will be 1 when the switch is Off. The control mode will be 2 when the Enable/Off/Remote Contact switch input is On and the CHIL_S_S variable is 'Stop.' Similarly, the control mode will be 6 when the CHIL_S_S variable is 'Start.'

Table 8 illustrates how the control method and cooling set point select variables direct the operation of the chiller and the set point to which it controls. The illustration also shows the ON/OFF state of the machine for the given combinations.

Cooling Set Point Select

SINGLE — Unit operation is based on Cooling Set Point 1 (CSP1) [Set Point, COOL].

DUAL SWITCH — Unit operation is based on Cooling Set Point 1 (CSP1) [Set Point, COOL] when the Dual Set Point switch contacts are open and Cooling Set Point 2 (CSP2) [Set Point, COOL] when they are closed.

DUAL CCN OCCUPIED — Unit operation is based on Cooling Set Point 1 (CSP1) [Set Point, COOL] during the Occupied mode and Cooling Set Point 2 (CSP2) [Set Point, COOL] during the Unoccupied mode as configured under the local occupancy schedule accessible only from CCN. Schedule Number in Table SCHEDOVR (See Appendix A) must be configured to 1. If the Schedule Number is set to 0, the unit will operate in a continuous 24-hr Occupied mode. Control method must be configured to 0 (switch). See Table 8.

4 TO 20 mA INPUT — Unit operation is based on an external 4 to 20 mA signal input to the Energy Management Module (EMM).

LOW SOUND MODE OPERATION — All models are factory configured with the Low Sound Mode disabled. In the Configuration mode under sub-mode OPT2, items for low sound mode select (LS.MD), low sound start time (LS.ST), low sound end time (LS.ND) and low sound capacity limit (LS.LT) are factory configured so that the chiller always runs as quietly as possible. This results in operation at increased saturated condensing temperature. As a result, some models may not be able to achieve rated efficiency. For chiller operation at rated efficiency, disable the low sound mode or adjust the low sound mode start and stop times accordingly or set both times to 00:00 for rated efficiency operation 24 hours per day. In addition, the low sound capacity limit can be used to reduce overall chiller capacity, if required, by limiting the maximum to a user-configured percentage.

Table 8 — Control Methods and Cooling Set Points

CONTROL TYPE (CTRL)	OCCUPANCY STATE	COOLING SET POINT SELECT (CLSP)			
		0 (single)	1 (dual, switch)	2 (dual, occ)	3 (4 to 20 mA)
0 (switch)	Occupied	ON,CSP1	ON*	ON,CSP1	ON†
	Unoccupied	ON,CSP1	ON*	ON,CSP2	ON
2 (Occupancy)	Occupied	ON,CSP1	ON*	Illegal	ON†
	Unoccupied	OFF	OFF	Illegal	OFF
3 (CCN)	Occupied	ON,CSP1	ON*	ON,CSP1	ON†
	Unoccupied	ON,CSP1	ON*	ON,CSP2	ON†

*Dual set point switch input used. CSP1 used when switch input is open. CSP2 used when switch input is closed.
 †Cooling set point determined from 4 to 20 mA input to Energy Management Module (EMM) to terminals TB6-3,5.

HEATING OPERATION — The chiller can be used for pump outputs or optional factory-installed hydronic system operation can be utilized for heating applications. The heating mode is activated when the control sees a field-supplied closed switch input to terminal block TB5-7,8. The control locks out cooling when the heat relay input is seen. A field-supplied boiler relay connection is made using heat relay and alarm relay contacts. Factory-installed ‘BOILER’ connections exist in the control panel near TB5 for these applications. Alarms and alerts A189 through A202 are active during heating operation.

Marquee Display Usage (See Fig. 16 and Tables 8-27) — The Marquee display module provides the user interface to the *ComfortLink™* control system. The display has up and down arrow keys, an **ESCAPE** key, and an **ENTER** key. These keys are used to navigate through the different levels of the display structure. See Table 9. Press the **ESCAPE** key until the display is blank to move through the top 11 mode levels indicated by LEDs on the left side of the display.

Pressing the **ESCAPE** and **ENTER** keys simultaneously will scroll a clear language text description across the display indicating the full meaning of each display acronym. Pressing the **ESCAPE** and **ENTER** keys when the display is blank (Mode LED level) will return the Marquee display to its default menu of rotating display items. In addition, the password will be disabled requiring that it be entered again before changes can be made to password protected items.

Clear language descriptions in English, Spanish, French, or Portuguese can be displayed when properly configuring the LANG Item in the Configuration Mode, under the Display (DISP) submode. See Table 17. Throughout this text, the location of items in the menu structure will be described in the following format:

Item Expansion (ITEM) [Mode Name, Sub-mode Name]
 For example, using the language selection item:
 Language Selection (LANG) [Configuration, DISP]

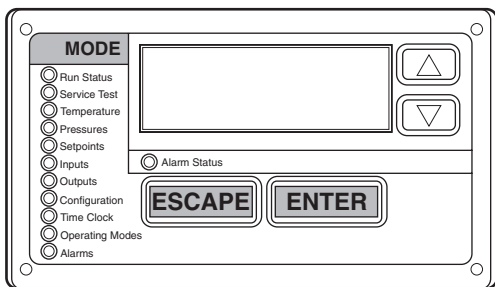


Fig. 16 — Scrolling Marquee Display

NOTE: When the LANG variable is changed to 1, 2, or 3, all appropriate display expansions will immediately change to the new language. No power-off or control reset is required when reconfiguring languages.

When a specific item is located, the display will flash showing the operator, the item, followed by the item value and then followed by the item units (if any). Press the **ENTER** key to stop the display at the item value. Items in the Configuration and Service Test modes are password protected. The display will flash PASS and WORD when required. Use the **ENTER** and arrow keys to enter the 4 digits of the password. The default password is 1111.

Changing item values or testing outputs is accomplished in the same manner. Locate and display the desired item. Press **ENTER** to stop the display at the item value. Press the **ENTER** key again so that the item value flashes. Use the arrow keys to change the value or state of an item and press the **ENTER** key to accept it. Press the **ESCAPE** key and the item, value, or units display will resume. Repeat the process as required for other items.

See Tables 8-27 for further details.

Service Test (See Table 11) — Both main power and control circuit power must be on.

The Service Test function should be used to verify proper operation of condenser fan(s), compressors, minimum load valve solenoid (if installed), cooler pump(s) and remote alarm relay. To use the Service Test mode, the Enable/Off/Remote Contact switch must be in the OFF position. Use the display keys and Table 11 to enter the mode and display TEST. Press **ENTER** twice so that OFF flashes. Enter the password if required. Use either arrow key to change the TEST value to the ON position and press **ENTER**. Press **ESCAPE** and the **▼** button to enter the OUTS or COMP sub-mode.

Test the condenser fans, cooler pump(s) and alarm relay by changing the item values from OFF to ON. These discrete outputs are then turned off if there is no keypad activity for 10 minutes. Test the compressor and minimum load valve solenoid (if installed) outputs in a similar manner. The minimum load valve solenoids will be turned off if there is no keypad activity for 10 minutes. Compressors will stay on until they are turned off by the operator. The Service Test mode will remain enabled for as long as there is one or more compressors running. All safeties are monitored during this test and will turn a compressor, circuit or the machine off if required. Any other mode or sub-mode can be accessed, viewed, or changed during the TEST mode. The STAT item [Run/Status, VIEW] will display ‘0’ as long as the Service mode is enabled. The TEST sub-mode value must be changed back to OFF before the chiller can be switched to Enable or Remote contact for normal operation.

Optional Factory-Installed Hydronic Package —

If the chiller has factory-installed chilled fluid pumps, specific steps should be followed for proper operation.

The pump(s) in the hydronic package come factory pre-wired into the main unit power supply/starter. In order to check proper pump rotation, use the Service Test function to test the condenser fans and observe them for proper rotation (counter clockwise when viewed from the top). If fans turn correctly, the pumps will rotate correctly. Clockwise rotation of the pump motor cooling fans can also be used to determine that pumps are rotating correctly.

⚠ CAUTION

Operation of pump in wrong direction, even for a few seconds, can cause irreversible damage to pump impeller and housing. Always verify correct wiring/pump rotation before operation.

Use Service Test function to test operation of pumps. Verify that the flow switch input is made when the pump is running. For dual pump hydronic systems, the control only uses one pump at a time. Consult the Installation Instructions supplied with this chiller and use the circuit setter balancing valve installed in hydronic package to adjust fluid flow rate.

Cooler Pump Control — The 30RA AquaSnap® machines equipped with a factory installed pump package are configured with the Cooler Pump Control (CPC) [Configuration, OPT1] ON.

Machines not equipped with a pump package are configured with the cooler pump control OFF. It is recommended that the machine control the chilled water pump. If not, a 5-minute time delay is required after the command to shut the machine down is sent before the chilled water pump is turned off. This is required to maintain water flow during the shutdown period of the machine.

With or without this option enabled, the cooler pump relay will be energized when the machine enters an ON status (i.e., On Local, On CCN, On Time). An A207 - Cooler Freeze Protection Alarm, will energize the cooler pump relay also, as an override. The cooler pump relay will remain energized if the machine is in MODE 10 – Minimum Off Time.

Cooler Pump Sequence of Operation — At any-time the unit is in an ON status, as defined by the one of the following conditions, the cooler pump relay will be enabled.

1. The Enable-Off-Remote Switch in ENABLE, (CTRL=0).
2. Enable-Off-Remote Switch in REMOTE with a Start-Stop remote contact closure, (CTRL=0).
3. An Occupied Time Period from an Occupancy Schedule in combination with items 1 or 2, (CTRL=2).
4. A CCN Start-Stop Command to Start in combination with items 1 or 2, (CTRL=3).

As stated before, there are certain alarm conditions and Operating Modes that will turn the cooler pump relay ON. This sequence will describe the normal operation of the pump control algorithm.

When the unit cycles from an “On” state to an “Off” state, the cooler pump output will remain energized for the Cooler Pump Shutdown Delay (PM.DY) [Configuration, OPT1]. This is configurable from 0 to 10 minutes. The factory default is 1 minute. If the pump output was deenergized during the transition period, the pump output will not be energized.

NO INTEGRAL PUMP — SINGLE EXTERNAL PUMP CONTROL — With a single external pump, the following options must be configured:

- Cooler Pump Control (CPC) [Configuration, OPT1] OFF.

- Cooler Pump 1 Enable (PM1E) [Configuration, UNIT] NO.
- Cooler Pump 2 Enable (PM2E) [Configuration, UNIT] NO.

The maximum load allowed for the Chilled Water Pump Starter is 5 VA sealed, 10 VA inrush at 24 volts. The starter coil is powered from the chiller control system. The starter should be wired between TB5-11 and TB5-13. If equipped, the field-installed chilled water pump starter auxiliary contacts should be connected in series with the chilled water flow switch.

The Cooler Pump Relay will be energized when the machine is “On.” The chilled water pump interlock circuit consists of a chilled water flow switch and a field-installed chilled water pump interlock. If the chilled water pump interlock circuit does not close within five (5) minutes of starting, an A200 — Cooler Flow/Interlock failed to close at Start-Up alarm will be generated and chiller will not be allowed to start.

If the chilled water pump interlock or chilled water flow switch opens for at least three (3) seconds after initially being closed, an A201 — Cooler Flow/Interlock Contacts Opened During Normal Operation Alarm will be generated and the machine will stop.

NO INTEGRAL PUMP — DUAL EXTERNAL PUMP CONTROL — With two external pumps, the following options must be configured:

- Cooler Pump Control (CPC) [Configuration, OPT1] ON.
- Cooler Pump 1 Enable (PM1E) [Configuration, UNIT] YES.
- Cooler Pump 2 Enable (PM2E) [Configuration, UNIT] YES.

The maximum load allowed for the Chilled Water Pump Starters is 5 VA sealed, 10 VA inrush at 24 volts. The starter coil is powered from the chiller control system. The starter for Chilled Water Pump 1 should be wired between TB5-11 and TB5-13. The starter for Chilled Water Pump 2 should be wired between TB5-15 and TB5-13. A field-installed chilled water pump interlock for each pump must be connected to each pump’s interlock points on the Main Base Board. The Chilled Water Pump 1 Interlock, CWP1, must be connected to MBB-J7-1 and -2. The Chilled Water Pump 2 Interlock, CWP2, must be connected to MBB-J7-3 and -4. The chilled water pump interlock contacts should be rated for dry circuit application capable of handling 5 vdc at 2 mA.

SINGLE INTEGRAL PUMP CONTROL — With a single pump, the following options must be configured:

- Cooler Pump Control (CPC) [Configuration, OPT1] ON.
- Cooler Pump 1 Enable (PM1E) [Configuration, UNIT] YES.
- Cooler Pump 2 Enable (PM2E) [Configuration, UNIT] NO.

With a single integral pump, the Cooler Pump Starter will be energized when the machine is occupied. As part of the factory-installed package, an auxiliary set of contacts is wired to the MBB to serve as Chilled Water Pump Interlock. When the mechanical cooling is called for, the pump interlock and flow switch is checked. If the circuits are closed, the machine starts its capacity routine. If the auxiliary contact interlock does not close within 25 seconds of the ON command, a T190 — Cooler Pump 1 Aux Contacts Failed to Close at Start-Up Alert will be generated and the pump shut down. The unit will not be allowed to start. If the chilled water flow switch does not close within one (1) minute, two alarms will be generated. A T192 — Cooler Pump 1 Failed to Provide Flow at Start-Up Alert and an A200 – Cooler Flow/Interlock failed to close at Start-Up will be generated and chiller will not be allowed to start.

If the chilled water flow switch opens for at least 3 seconds after initially being closed, a T196 — Flow Lost While Pump 1 Running Alert and an A201 — Cooler Flow/Interlock Contacts

Opened During Normal Operation Alarm will be generated and the machine will stop.

If the control detects the chilled water pump interlock open for 25 seconds after initially being closed, a T194 — Cooler Pump 1 Contacts Opened During Normal Operation Alert is generated and the unit is shut down.

If the control detects the chilled water flow switch circuit closed for at least 5 minutes with the pump output OFF, an A202 — Cooler Pump Interlock Closed When Pump is Off Alarm will be generated and the unit will not be allowed to start.

If the control detects that the chilled water pump auxiliary contacts are closed for at least 25 seconds while the pump is OFF, a T198 — Cooler Pump 1 Aux Contacts Closed While Pump Off Alert is generated. The chiller will not be allowed to start.

If the control starts a pump and the wrong interlock circuit closes for at least 20 seconds, an A189 — Cooler Pump and Aux Contact Input Miswire Alarm will be generated. The unit will be prevented from starting.

As part of a pump maintenance routine, the pump can be started to maintain lubrication of the pump seal. To utilize this function, Cooler Pmp Periodic Start (PM.P.S) [Configuration, UNIT] must be set to YES. This option is set to NO as the factory default. With this feature enabled, if the pump is not operating, it will be started and operated for 2 seconds starting at 14:00 hours. If the pump is operating, this routine is skipped. If the pump has failed and an Alarm/Alert condition is active, the pump will not start that day.

DUAL INTEGRAL PUMP CONTROL — With a dual integral pump package, the following options must be configured:

- Cooler Pump Control (CPC) [Configuration, OPT1] ON.
- Cooler Pump 1 Enable (PM1E) [Configuration, UNIT] YES
- Cooler Pump 2 Enable (PM2E) [Configuration, UNIT] YES

Pump Start Selection is a field-configurable choice. Cooler Pump Select (PM.SL) [Configuration, UNIT] is factory defaulted to 0 (Automatic). This value can be changed to 1 (Pump 1 Starts First) or 2 (Pump 2 Starts First). If PM.SL is 0 (Automatic), the pump selection is based on two criteria: the alert status of a pump and the operational hours on the pump. If a pump has an active Alert condition, it will not be considered for the lead pump. The pump with the lowest operational hours will be the lead pump. A pump is selected by the control to start and continues to be the lead pump until the Pump Changeover Hours (PM.DT) [Configuration, UNIT] is reached. The Lead Pump (LD.PM) [Run Status, VIEW] indicates the pump that has been selected as the lead pump: 1 (Pump 1), 2 (Pump 2), 3 (No Pump). The Pump Changeover Hours is factory defaulted to 500 hours. Regardless of the Cooler Pump Selection, any pump that has an active alert will not be allowed to start.

With the dual integral pump package, the Cooler Pump Starter will be energized when the machine is in an occupied period. As part of the factory-installed package, an auxiliary set of contacts is wired to the MBB to serve as Chilled Water Pump Interlock, one set for each pump to individual channels on the MBB. With a call for mechanical cooling, the specific pump interlock and flow switch are checked. If the circuits are closed, the machine starts its capacity routine. If Pump 1 starts and the auxiliary contact interlock does not close within 25 seconds of the ON command, a T190 – Cooler Pump 1 Aux Contacts Failed to Close at Start-Up Alert will be generated and the pump shut down. The unit will not be allowed to start. If the chilled water flow switch does not close within 1 minute, two alarms will be generated. A T192 – Cooler Pump 1 Failed to Provide Flow at Start-Up Alert and an A200 – Cooler Flow/Interlock failed to close at Start-Up will be generated and chiller

will not be allowed to start. In either fault case listed above, Pump 2 will be commanded to start once Pump 1 has failed.

If Pump 2 starts and the auxiliary contact interlock does not close within 25 seconds of the ON command, a T191 — Cooler Pump 2 Aux Contacts Failed to Close at Start-Up Alert will be generated and the pump shut down. The unit will not be allowed to start. If the chilled water flow switch does not close within one (1) minute, two alarms will be generated. A T193 — Cooler Pump 2 Failed to Provide Flow at Start-Up Alert and an A200 – Cooler Flow/Interlock failed to close at Start-Up will be generated and chiller will not be allowed to start. In either fault case listed above, Pump 1 will be commanded to start once Pump 2 has failed.

If the chilled water flow switch opens for at least 3 seconds after initially being closed, a T196 — Flow Lost While Pump 1 Running Alert or T197 — Flow Lost While Pump 2 Running Alert for the appropriate pump and an A201 — Cooler Flow/Interlock Contacts Opened During Normal Operation Alarm will be generated and the machine will stop. If available, the other pump will be started. If flow is proven, the machine will be allowed to restart.

If the chilled water pump interlock opens for 25 seconds after initially being closed is detected by the control, the appropriate T194 – Cooler Pump 1 Contacts Opened During Normal Operation Alert or T195 – Cooler Pump 2 Contacts Opened During Normal Operation Alert is generated and the unit is shut down. If available, the other pump will be started. If flow is proven, the machine will be allowed to restart.

If the control detects that the chilled water flow switch circuit is closed for at least 5 minutes with the pump output OFF, an A202 – Cooler Pump Interlock Closed When Pump is Off Alarm will be generated and the unit will not be allowed to start.

If the control detects that the chilled water pump auxiliary contacts are closed for at least 25 seconds while the pump is OFF, the appropriate T198 – Cooler Pump 1 Aux Contacts Closed While Pump Off or Alert T199 – Cooler Pump 2 Aux Contacts Closed While Pump Off Alert is generated. The chiller will not be allowed to start.

If the control starts a pump and the wrong interlock circuit closes for at least 20 seconds, an A189 – Cooler Pump and Aux Contact Input Miswire Alarm will be generated. The unit will be prevented from starting.

The control will allow for pump changeover. Two methods will change the pump sequence. Before the changeover can occur, the unit must be at Capacity Stage 0. During changeover the chilled water flow switch input is ignored for 10 seconds to avoid a nuisance alarm.

With Cooler Pump Select (PM.SL) [Configuration, UNIT] set to 0 (Automatic) and when the differential time limit Pump Changeover Hours (PM.DT) [Configuration, UNIT] is reached, the lead pump will be turned OFF. Approximately one (1) second later, the lag pump will start. Manual changeover can be accomplished by changing Rotate Cooler Pump Now (ROT.P) [Configuration, UNIT] to YES only if the machine is at Capacity Stage 0 and the differential time limit Pump Changeover Hours (PM.DT) [Configuration, UNIT] is reached. If the PM.DT is not satisfied, the changeover will not occur. With the machine at Capacity Stage 0, the pumps would rotate automatically as part of the normal routine.

With Cooler Pump Select (PM.SL) [Configuration, UNIT] set to 1 (Pump 1 Starts First) or 2 (Pump 2 Starts First), a manual changeover can be accomplished by changing PM.SL only. The machine Remote-Off-Enable Switch must be in the OFF position to change this variable. The Rotate Cooler Pump Now (ROT.P) [Configuration, UNIT] feature does not work for these configuration options.

As part of a pump maintenance routine, the pumps can be started to maintain lubrication to the pump seal. To utilize this function, Cooler Pmp Periodic Start (PM.PS) [Configuration, UNIT] must be set to YES. This option is set to NO as the factory default. If feature is enabled and the pump(s) are not operating, then the pumps will be operated every other day for 2 seconds starting at 14:00 hours. If a pump has failed and has an active Alert condition, it will not be started that day.

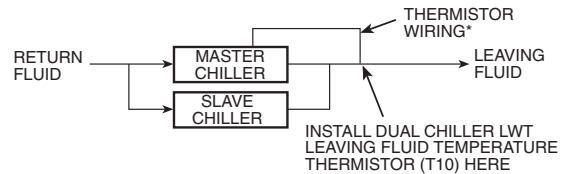
Configuring and Operating Dual Chiller Control — The dual chiller routine is available for the control of two units supplying chilled fluid on a common loop. This control algorithm is designed for parallel fluid flow arrangement only. One chiller must be configured as the master chiller, the other as the slave. An additional leaving fluid temperature thermistor (Dual Chiller LWT) must be installed as shown in Fig. 17 and connected to the master chiller. Refer to Sensors section, page 4, for wiring. The CCN communication bus must be connected between the two chillers. Connections can be made to the CCN screw terminals on TB3. Refer to Carrier Comfort Network Interface section, page 3, for wiring information.

Refer to Table 21 for dual chiller configuration. In this example the master chiller will be configured at address 1 and the slave chiller at address 2. The master and slave chillers must reside on the same CCN bus (CCNB) but cannot have the same CCN address (CCNA) [Configuration, OPT2]. Both master and slave chillers must have Lead/Lag Chiller Enable (LLEN) [Configuration, RSET] configured to ENBL. Master/Slave Select (MSSL) [Configuration, RSET] must be configured to MAST for the master chiller and SLVE for the slave. Also in this example, the master chiller will be configured to use Lead/Lag Balance Select (LLBL) and Lead/Lag Balance Delta (LLBD) [Configuration, RSET] to even out the chiller run-times weekly. The Lag Start Delay (LLDY) [Configuration, RSET] feature will be set to 10 minutes. This will prevent the lag chiller from starting until the lead chiller has been at 100% capacity for the length of the delay time. Parallel configuration (PARA) [Configuration, RSET] can only be configured to YES. The variables LLBL, LLBD and LLDY are not used by the slave chiller.

Dual chiller start/stop control is determined by configuration of Control Method (CTRL) [Configuration, OPT2] of the Master chiller. The Slave chiller should always be configured for CTRL=0, *Switch*. If the chillers are to be controlled by Remote Contacts, both Master and Slave chillers should be enabled together. Two separate relays or one relay with two sets of contacts may control the chillers. The Enable/Off/Remote Contact switch should be in the Remote Contact position on both the Master and Slave chillers. The Enable/Off/Remote Contact switch should be in the Enable position for CTRL=2, *Occupancy* or CTRL=3, *CCN Control*.

Both chillers will stop if the Master chiller Enable/Off/Remote Contact switch is in the Off position. If the Emergency Stop switch is turned off or an alarm is generated on the Master chiller the Slave chiller will operate in a Stand-Alone mode. If the Emergency Stop switch is turned off or an alarm is generated on the Slave chiller the Master chiller will operate in a Stand-Alone mode.

The master chiller controls the slave chiller by changing its Control Mode (STAT) [Run Status, VIEW] and its operating setpoint or Control Point (CTPT) [Run Status, VIEW].



- *Depending on piping sizes, use either:
- HH79NZ014 sensor/10HB50106801 well (3-in. sensor/well)
 - HH79NZ029 sensor/10HB50106802 well (4-in. sensor/well)

Fig. 17 — Dual Chiller Thermistor Location

Table 9 — Marquee Display Menu Structure*

MODE	RUN STATUS	SERVICE TEST	TEMPERATURES	PRESSURES	SET POINTS	INPUTS	OUTPUTS	CONFIGURATION	TIME CLOCK	OPERATING MODES	ALARMS
SUB-MODE	Auto Display (VIEW)	Manual Mode On/Off (TEST)	Unit Temperatures (UNIT)	Ckt A Pressures (PRC.A)	Cooling (COOL)	Unit Discrete (GEN.I)	Unit Discrete (GEN.O)	Display (DISP)	Unit Time (TIME)	Modes (MODE)	Current (CRNT)
	Machine Hours/Starts (RUN)	Unit Outputs (OUTS)	Ckt A Temperatures (CIR.A)	Ckt B Pressures (PRC.B)	Head Pressure (HEAD)	Ckt A/B (CRCT)	Ckt A (CIR.A)	Machine (UNIT)	Unit Date (DATE)		Reset Alarms (RCRN)
	Compressor Run Hours (HOUR)	Ckt A Comp Tests (CMPA)	Ckt B Temperatures (CIR.B)		Brine Freeze-point (FRZ)	Unit Analog (4-20)	Ckt B (CIR.B)	Options 1 (OPT1)	Daylight Saving Time (DST)		Alarm History (HIST)
	Compressor Starts (STRT)	Ckt B Comp Tests (CMPB)						Options 2 (OPT2)	Schedule Number (SCH.N)		
	Pump Maint. (PM)							Temperature Reset (RSET)	Local Schedule (SCH.L)		
	Software Version (VERS)							Set Point Select (SLCT)	Schedule Override (OVR)		
								Service Configuration (SERV)			
								Broadcast Configuration (BCST)			

LEGEND

Ckt — Circuit

*Throughout this text, the location of items in the menu structure will be described in the following format:

Item Expansion (ITEM) [Mode Name, Sub-mode Name]

For example, using the language selection item:

Language Selection (LANG) [Configuration, DISP]

Table 10 — Run Status Mode and Sub-Mode Directory

SUB-MODE	KEYPAD ENTRY	ITEM	DISPLAY	SUB-ITEM	DISPLAY	SUB-ITEM	DISPLAY	ITEM EXPANSION	COMMENT	
VIEW	ENTER	EWT	XXX.X °F					ENTERING FLUID TEMP		
	↓	LWT	XXX.X °F					LEAVING FLUID TEMP		
	↓	SETP	XXX.X °F					ACTIVE SETPOINT		
	↓	CTPT	XXX.X °F					CONTROL POINT		
	↓	LOD.F	XXX					LOAD/UNLOAD FACTOR		
	↓	STAT	X					CONTROL MODE	0 = Service Test 1 = Off Local 2 = Off CCN 3 = Off Time 4 = Off Emrgcy 5 = On Local 6 = On CCN 7 = On Time 8 = Ht Enabled 9 = Pump Delay	
	↓	LD.PM						LEAD PUMP		
	↓	OCC	YES/NO					OCCUPIED		
	↓	LS.AC	YES/NO					LOW SOUND ACTIVE		
	↓	MODE	YES/NO					OVERRIDE MODES IN EFFECT		
	↓	CAP	XXX %					PERCENT TOTAL CAPACITY		
	↓	STGE	X					REQUESTED STAGE		
	↓	ALRM	XXX					CURRENT ALARMS & ALERTS		
	↓	TIME	XX.XX					TIME OF DAY	00.00-23.59	
RUN	ENTER	HRS.U	XXXX HRS					MACHINE OPERATING HOURS		
	↓	STR.U	XXXX					MACHINE STARTS		
	↓	HR.P1	XXXX.X					PUMP 1 RUN HOURS		
	↓	HR.P2	XXXX.X					PUMP 2 RUN HOURS		
	HOUR	ENTER	HRS.A	XXXX HRS					CIRCUIT A RUN HOURS	
		↓	HRS.B	XXXX HRS					CIRCUIT B RUN HOURS	See Note
		↓	HR.A1	XXXX HRS					COMPRESSOR A1 RUN HOURS	
		↓	HR.A2	XXXX HRS					COMPRESSOR A2 RUN HOURS	
		↓	HR.B1	XXXX HRS					COMPRESSOR B1 RUN HOURS	See Note
		↓	HR.B2	XXXX HRS					COMPRESSOR B2 RUN HOURS	See Note
	STRT	ENTER	ST.A1	XXXX					COMPRESSOR A1 STARTS	
		↓	ST.A2	XXXX					COMPRESSOR A2 STARTS	
		↓	ST.B1	XXXX					COMPRESSOR B1 STARTS	See Note
		↓	ST.B2	XXXX					COMPRESSOR B2 STARTS	See Note
PM	ENTER	PUMP						PUMP MAINTENANCE		
	ENTER			SI.PM	XXXX HRS			PUMP SERVICE INTERVAL		
	↓			P.1.DN	XXXX HRS			PUMP 1 SERVICE COUNTDOWN		
	↓			P.2.DN	XXXX HRS			PUMP 2 SERVICE COUNTDOWN		
	↓			P.1.MN	YES/NO			PUMP 1 MAINTENANCE DONE	User Entry	
	↓			P.2.MN	YES/NO			PUMP 2 MAINTENANCE DONE	User Entry	

NOTE: If the unit has a single circuit, the Circuit B items will not appear in the display, except the ability to configure circuit B will be displayed.

Table 10 — Run Status Mode and Sub-Mode Directory (cont)

SUB-MODE	KEYPAD ENTRY	ITEM	DISPLAY	SUB-ITEM	DISPLAY	SUB-ITEM	DISPLAY	ITEM EXPANSION	COMMENT	
PM (cont)	↓			PMDT				PUMP MAINTENANCE DATES		
	ENTER					P.1.M0		MM/DD/YY HH:MM		
	↓					P.1.M1		MM/DD/YY HH:MM		
	↓					P.1.M2		MM/DD/YY HH:MM		
	↓					P.1.M3		MM/DD/YY HH:MM		
	↓					P.1.M4		MM/DD/YY HH:MM		
	↓					P.2.M0		MM/DD/YY HH:MM		
	↓					P.2.M1		MM/DD/YY HH:MM		
	↓					P.2.M2		MM/DD/YY HH:MM		
	↓					P.2.M3		MM/DD/YY HH:MM		
	↓					P.2.M4		MM/DD/YY HH:MM		
	ENTER	STRN							STRAINER MAINTENANCE	
	ENTER				SI.ST	XXXX HRS			STRAINER SRVC INTERVAL	
	↓				S.T.DN	XXXX HRS			STRAINER SRVC COUNTDOWN	
	↓				S.T.MN	YES/NO			STRAINER MAINT. DONE	User Entry
	↓				ST.DT				STRAINER MAINT. DATES	
	ENTER						S.T.M0		MM/DD/YY HH:MM	
	↓						S.T.M1		MM/DD/YY HH:MM	
	↓						S.T.M2		MM/DD/YY HH:MM	
	↓						S.T.M3		MM/DD/YY HH:MM	
	↓						S.T.M4		MM/DD/YY HH:MM	
	ENTER	COIL							COIL MAINTENANCE	
	ENTER				SI.CL	XXXX HRS			COIL SRVC INTER	
	↓				C.L.DN	XXXX HRS			COIL SERVICE COUNTDOWN	
	↓				C.L.MN	YES/NO			COIL MAINT. DONE	User Entry
	↓				CL.DT				COIL MAINTENANCE DATES	
	ENTER						C.L.M0		MM/DD/YY HH:MM	
	↓						C.L.M1		MM/DD/YY HH:MM	
	↓						C.L.M2		MM/DD/YY HH:MM	
	↓						C.L.M3		MM/DD/YY HH:MM	
	↓						C.L.M4		MM/DD/YY HH:MM	
	VERS	ENTER	MBB						CESR-131279-xx-xx	xx-xx is Version number*
		↓	MARQ						CESR-131171-xx-xx	xx-xx is Version number*
		↓	EMM						CESR-131174-xx-xx	xx-xx is Version number*
↓		NAVI						CESR-131227-xx-xx	xx-xx is Version number*	



*Press  and  simultaneously to obtain version number.

Table 11 — Service Test Mode and Sub-Mode Directory

SUB-MODE	KEYPAD ENTRY	ITEM	DISPLAY	ITEM EXPANSION	COMMENT
TEST	ENTER		ON/OFF	SERVICE TEST MODE	To Enable Service Test Mode, move Enable/Off/Remote Contact switch to OFF. Change TEST to ON. Move switch to ENABLE.
OUTS				OUTPUTS AND PUMPS	
	ENTER	FAN1	ON/OFF	FAN 1 RELAY	
	↓	FAN2	ON/OFF	FAN 2 RELAY	
	↓	CLP.1	ON/OFF	COOLER PUMP 1 RELAY	
	↓	CLP.2	ON/OFF	COOLER PUMP 2 RELAY	
	↓	CL.HT	ON/OFF	COOLER/PUMP HEATER	
	↓	RMT.A	ON/OFF	REMOTE ALARM RELAY	
CMPA				CIRCUIT A COMPRESSOR TEST	
	ENTER	CC.A1	ON/OFF	COMPRESSOR A1 RELAY	
	↓	CC.A2	ON/OFF	COMPRESSOR A2 RELAY	
	↓	MLV	ON/OFF	MINIMUM LOAD VALVE RELAY	
CMPB				CIRCUIT B COMPRESSOR TEST	See Note
	ENTER	CC.B1	ON/OFF	COMPRESSOR B1 RELAY	
	↓	CC.B2	ON/OFF	COMPRESSOR B2 RELAY	
	↓	MLV	ON/OFF	MINIMUM LOAD VALVE RELAY	

NOTE: If the unit has a single circuit, the Circuit B items will not appear in the display, except the ability to configure circuit B will be displayed.

Table 12 — Temperature Mode and Sub-Mode Directory

SUB-MODE	KEYPAD ENTRY	ITEM	DISPLAY	ITEM EXPANSION	COMMENT
UNIT				ENT AND LEAVE UNIT TEMPS	
	ENTER	CEWT	XXX.X °F	COOLER ENTERING FLUID	
	↓	CLWT	XXX.X °F	COOLER LEAVING FLUID	
	↓	OAT	XXX.X °F	OUTSIDE AIR TEMPERATURE	
	↓	SPT	XXX.X °F	SPACE TEMPERATURE	
	↓	DLWT	XXX.X °F	LEAD/LAG LEAVING FLUID	
CIR.A				TEMPERATURES CIRCUIT A	
	ENTER	SCT.A	XXX.X °F	SATURATED CONDENSING TMP	
	↓	SST.A	XXX.X °F	SATURATED SUCTION TEMP	
	↓	RG.T.A	XXX.X °F	COMPR RETURN GAS TEMP	
CIR.B				TEMPERATURES CIRCUIT B	See Note
	ENTER	SCT.B	XXX.X °F	SATURATED CONDENSING TMP	See Note
	↓	SST.B	XXX.X °F	SATURATED SUCTION TEMP	See Note
	↓	RG.T.B	XXX.X °F	COMPR RETURN GAS TEMP	See Note
	↓	SH.B	XXX.X ^F	SUCTION SUPERHEAT TEMP	See Note

NOTE: If the unit has a single circuit, the Circuit B items will not appear in the display, except the ability to configure circuit B will be displayed.

Table 13 — Pressure Mode and Sub-Mode Directory

SUB-MODE	KEYPAD ENTRY	ITEM	DISPLAY	ITEM EXPANSION	COMMENT
PRC.A				PRESSURES CIRCUIT A	
	ENTER	DP.A	XXX.X PSIG	DISCHARGE PRESSURE	
	↓	SPA	XXX.X PSIG	SUCTION PRESSURE	
PRC.B				PRESSURES CIRCUIT B	See Note
	ENTER	DP.B	XXX.X PSIG	DISCHARGE PRESSURE	See Note
	↓	SP.B	XXX.X PSIG	SUCTION PRESSURE	See Note

NOTE: If the unit has a single circuit, the Circuit B items will not appear in the display, except the ability to configure circuit B will be displayed.

Table 14 — Set Point and Sub-Mode Directory

SUB-MODE	KEYPAD ENTRY	ITEM	DISPLAY	ITEM EXPANSION	COMMENT
COOL				COOLING SETPOINTS	
	ENTER	CSP.1	XXX.X °F	COOLING SETPOINT 1	Default: 44 F
	↓	CSP.2	XXX.X °F	COOLING SETPOINT 2	Default: 44 F
	↓	CSP.3	XXX.X °F	ICE SETPOINT	Default: 32 F
HEAD				HEAD PRESSURE SETPOINTS	
	ENTER	HD.P.A	XXX.X °F	CALCULATED HP SETPOINT A	Default: 113 F (Read Only)
	↓	HD.P.B	XXX.X °F	CALCULATED HP SETPOINT B	Default: 113 F (Read Only)
FRZ				BRINE FREEZE SETPOINT	
	ENTER	BR.FZ	XXX.X °F	BRINE FREEZE POINT	Default: 34 F

Table 15 — Inputs Mode and Sub-Mode Directory

SUB-MODE	KEYPAD ENTRY	ITEM	DISPLAY	ITEM EXPANSION	COMMENT
GEN.I				GENERAL INPUTS	
	ENTER	STST	STRT/STOP	START/STOP SWITCH	
	↓	FLOW	ON/OFF	COOLER FLOW SWITCH	
	↓	PM.F.1	OPEN/CLSE	COOLER PUMP 1 INTERLOCK	
	↓	LD.PM	X	Lead Pump	1 = Pump 1 2 = Pump 2 3 = No Pump
	↓	PM.F.2	OPEN/CLSE	COOLER PUMP 2 INTERLOCK	
	↓	HT.RQ	ON/OFF	HEAT REQUEST	
	↓	DLS1	ON/OFF	DEMAND LIMIT SWITCH 1	
	↓	DLS2	ON/OFF	DEMAND LIMIT SWITCH 2	
	↓	ICED	ON/OFF	ICE DONE	
	↓	DUAL	ON/OFF	DUAL SETPOINT SWITCH	
CRCT				CIRCUITS INPUTS	
	ENTER	FKA1	ON/OFF	COMPRESSOR A1 FEEDBACK	
	↓	FKA2	ON/OFF	COMPRESSOR A2 FEEDBACK	
	↓	FKB1	ON/OFF	COMPRESSOR B1 FEEDBACK	See Note
	↓	FKB2	ON/OFF	COMPRESSOR B2 FEEDBACK	See Note
4-20				4-20 MA INPUTS	
	ENTER	DMND	XX.X MA	4-20 MA DEMAND SIGNAL	
	↓	RSET	XX.X MA	4-20 MA RESET SIGNAL	
	↓	CSP	XX.X MA	4-20 MA COOLING SETPOINT	

Table 16 — Outputs Mode and Sub-Mode Directory

SUB-MODE	KEYPAD ENTRY	ITEM	DISPLAY	ITEM EXPANSION	COMMENT
GEN.O				GENERAL OUTPUTS	
	ENTER	FAN1	ON/OFF	FAN 1 RELAY	
	↓	FAN2	ON/OFF	FAN 2 RELAY	
	↓	C.WP1	ON/OFF	COOLER PUMP RELAY 1	
	↓	C.WP2	ON/OFF	COOLER PUMP RELAY 2	
	↓	CLHT	ON/OFF	COOLER/PUMP HEATER	
	↓	MLV.R	ON/OFF	MINIMUM LOAD VALVE RELAY	
CIR.A				OUTPUTS CIRCUIT A	
	ENTER	CC.A1	ON/OFF	COMPRESSOR A1 RELAY	
	↓	CC.A2	ON/OFF	COMPRESSOR A2 RELAY	
CIR.B				OUTPUTS CIRCUIT B	See Note
	ENTER	CC.B1	ON/OFF	COMPRESSOR B1 RELAY	
	↓	CC.B2	ON/OFF	COMPRESSOR B2 RELAY	

NOTE: If the unit has a single circuit, the Circuit B items will not appear in the display, except the ability to configure circuit B will be displayed.

Table 17 — Configuration Mode and Sub-Mode Directory

SUB-MODE	KEYPAD ENTRY	ITEM	DISPLAY	ITEM EXPANSION	COMMENT																																										
DISP				DISPLAY CONFIGURATION																																											
	ENTER	TEST	ON/OFF	TEST DISPLAY LEDS																																											
	↓	METR	ON/OFF	METRIC DISPLAY	Off = English; On = Metric																																										
	↓	LANG	X	LANGUAGE SELECTION	Default: 0 0 = English 1 = Espanol 2 = Francais 3 = Portuguese																																										
	↓	PAS.E	ENBL/DSBL	PASSWORD ENABLE																																											
	↓	PASS	xxxx	SERVICE PASSWORD																																											
UNIT	ENTER			UNIT CONFIGURATION																																											
	↓	SZA.1	XX	COMPRESSOR A1 SIZE	<table border="1"> <thead> <tr> <th>Unit Size</th> <th>60 Hz</th> <th>50 Hz</th> </tr> </thead> <tbody> <tr><td>010</td><td>10</td><td>11</td></tr> <tr><td>015</td><td>15</td><td>7</td></tr> <tr><td>018</td><td>9</td><td>9</td></tr> <tr><td>022</td><td>9</td><td>11</td></tr> <tr><td>025</td><td>13</td><td>13</td></tr> <tr><td>030</td><td>15</td><td>—</td></tr> <tr><td>032</td><td>—</td><td>8</td></tr> <tr><td>035</td><td>9</td><td>13</td></tr> <tr><td>040</td><td>13</td><td>—</td></tr> <tr><td>042</td><td>—</td><td>11</td></tr> <tr><td>045</td><td>10</td><td>13</td></tr> <tr><td>050</td><td>13</td><td>—</td></tr> <tr><td>055</td><td>15</td><td>—</td></tr> </tbody> </table>	Unit Size	60 Hz	50 Hz	010	10	11	015	15	7	018	9	9	022	9	11	025	13	13	030	15	—	032	—	8	035	9	13	040	13	—	042	—	11	045	10	13	050	13	—	055	15	—
	Unit Size	60 Hz	50 Hz																																												
	010	10	11																																												
	015	15	7																																												
	018	9	9																																												
	022	9	11																																												
	025	13	13																																												
	030	15	—																																												
	032	—	8																																												
	035	9	13																																												
	040	13	—																																												
	042	—	11																																												
045	10	13																																													
050	13	—																																													
055	15	—																																													
↓	SZA.2	XX	COMPRESSOR A2 SIZE	<table border="1"> <thead> <tr> <th>Unit Size</th> <th>60 Hz</th> <th>50 Hz</th> </tr> </thead> <tbody> <tr><td>015</td><td>—</td><td>7</td></tr> <tr><td>018</td><td>9</td><td>9</td></tr> <tr><td>022</td><td>13</td><td>11</td></tr> <tr><td>025</td><td>13</td><td>13</td></tr> <tr><td>030</td><td>15</td><td>—</td></tr> <tr><td>032</td><td>—</td><td>11</td></tr> <tr><td>035</td><td>13</td><td>13</td></tr> <tr><td>040</td><td>13</td><td>—</td></tr> <tr><td>042</td><td>—</td><td>11</td></tr> <tr><td>045</td><td>13</td><td>13</td></tr> <tr><td>050</td><td>13</td><td>—</td></tr> <tr><td>055</td><td>15</td><td>—</td></tr> </tbody> </table>	Unit Size	60 Hz	50 Hz	015	—	7	018	9	9	022	13	11	025	13	13	030	15	—	032	—	11	035	13	13	040	13	—	042	—	11	045	13	13	050	13	—	055	15	—				
Unit Size	60 Hz	50 Hz																																													
015	—	7																																													
018	9	9																																													
022	13	11																																													
025	13	13																																													
030	15	—																																													
032	—	11																																													
035	13	13																																													
040	13	—																																													
042	—	11																																													
045	13	13																																													
050	13	—																																													
055	15	—																																													
↓	SZB.1	XX	COMPRESSOR B1 SIZE	<table border="1"> <thead> <tr> <th>Unit Size</th> <th>60 Hz</th> <th>50 Hz</th> </tr> </thead> <tbody> <tr><td>032</td><td>—</td><td>13</td></tr> <tr><td>035</td><td>15</td><td>13</td></tr> <tr><td>040</td><td>15</td><td>—</td></tr> <tr><td>042</td><td>—</td><td>11</td></tr> <tr><td>045</td><td>10</td><td>13</td></tr> <tr><td>050</td><td>13</td><td>—</td></tr> <tr><td>055</td><td>15</td><td>—</td></tr> </tbody> </table>	Unit Size	60 Hz	50 Hz	032	—	13	035	15	13	040	15	—	042	—	11	045	10	13	050	13	—	055	15	—																			
Unit Size	60 Hz	50 Hz																																													
032	—	13																																													
035	15	13																																													
040	15	—																																													
042	—	11																																													
045	10	13																																													
050	13	—																																													
055	15	—																																													
↓	SZB.2	XX	COMPRESSOR B2 SIZE	<table border="1"> <thead> <tr> <th>Unit Size</th> <th>60 Hz</th> <th>50 Hz</th> </tr> </thead> <tbody> <tr><td>042</td><td>—</td><td>11</td></tr> <tr><td>045</td><td>13</td><td>13</td></tr> <tr><td>050</td><td>13</td><td>—</td></tr> <tr><td>055</td><td>15</td><td>—</td></tr> </tbody> </table>	Unit Size	60 Hz	50 Hz	042	—	11	045	13	13	050	13	—	055	15	—																												
Unit Size	60 Hz	50 Hz																																													
042	—	11																																													
045	13	13																																													
050	13	—																																													
055	15	—																																													
↓	SH.SP	XX.X ΔF	SUPERHEAT SETPOINT	Default: 15 °F																																											
↓	REFG	X	REFRIGERANT	1 = R-22																																											
↓	FAN.S		FAN STAGING SELECT	1 = One Fan (010-018) 2 = Two Fans (022-030) 3 = Three Fans (032-040) 4 = Four Fans (042-055)																																											

NOTE: If the unit has a single circuit, the Circuit B items will not appear in the display, except the ability to configure circuit B will be displayed.

Table 17 — Configuration Mode and Sub-Mode Directory (cont)

SUB-MODE	KEYPAD ENTRY	ITEM	DISPLAY	ITEM EXPANSION	COMMENT
OPT1				UNIT OPTIONS 1 HARDWARE	
	ENTER	FLUD	X	COOLER FLUID	Default: Water 1 = Water 2 = Medium Temperature Brine
	↓	MLV.S	YES/NO	MINIMUM LOAD VALVE SELECT	
	↓	MMR.S	YES/NO	MOTORMASTER SELECT	
	↓	RG.EN	ENBL/DSBL	RETURN GAS SENSOR ENABLE	Default: DISABLED
	↓	CPC	ON/OFF	COOLER PUMP CONTROL	Default: On
	↓	PM1E	YES/NO	COOLER PUMP 1 ENABLE	
	↓	PM2E	YES/NO	COOLER PUMP 2 ENABLE	
	↓	PM.PS	YES/NO	COOLER PMP PERIODIC STRT	Default: No
	↓	PM.SL	X	COOLER PUMP SELECT	Default: Automatic 0 = Automatic 1 = Pump 1 Starts first 2 = Pump 2 Starts first
	↓	PM.DY	XX MIN	COOLER PUMP SHUTDOWN DLY	0 to 10 minutes, Default: 1 min.
	↓	PM.DT	XXXX HRS	PUMP CHANGEOVER HOURS	Default: 500 hours
	↓	ROT.P	YES/NO	ROTATE COOLER PUMPS NOW	User Entry
	↓	EMM	YES/NO	EMM MODULE INSTALLED	
OPT2				UNIT OPTIONS 2 CONTROLS	
	ENTER	CTRL	X	CONTROL METHOD	Default: Switch 0 = Enable/Off/Remote Switch 2 = Occupancy 3 = CCN Control
	↓	CCNA	XXX	CCN ADDRESS	Default: 1 Range: 1 to 239
	↓	CCNB	XXX	CCN BUS NUMBER	Default: 0 Range: 0 to 239
	↓	BAUD	X	CCN BAUD RATE	Default: 9600 1 = 2400 2 = 4800 3 = 9600 4 = 19,200 5 = 38,400
	↓	LOAD	X	LOADING SEQUENCE SELECT	Default: Equal 1 = Equal 2 = Staged
	↓	LLCS	X	LEAD/LAG CIRCUIT SELECT	Default: Automatic 1 = Automatic 2 = Circuit A Leads 3 = Circuit B Leads
	↓	LCWT	XX.X ΔF	HIGH LCW ALERT LIMIT	Default: 60 Range: 2 to 60 °F
	↓	DELY	XX	MINUTES OFF TIME	Default: 0 Minutes Range: 0 to 15 Minutes
	↓	ICE.M	ENBL/DSBL	ICE MODE ENABLE	Default: Disable
	↓	CLS.C	ENBL/DSBL	CLOSE CONTROL SELECT	Default: Disable
	↓	LS.MD	X	LOW SOUND MODE SELECT	Default: 0 0 = Mode Disable 1 = Fan Noise Only 2 = Fan/Compressor Noise
	↓	LS.ST	00:00	LOW SOUND START TIME	Default: 00:00
	↓	LS.ND	00:00	LOW SOUND END TIME	Default: 00:00
	↓	LS.LT	XXX %	LOW SOUND CAPACITY LIMIT	Default: 100% Range: 0 to 100%
	RSET				RESET COOL TEMP
ENTER		CRST	X	COOLING RESET TYPE	Default: No Reset 0 = No Reset 1 = 4 to 20 mA Input 2 = Outdoor Air Temperature 3 = Return Fluid 4 = Space Temperature
↓		MA.DG	XX.X ΔF	4-20 - DEGREES RESET	Default: 0.0 ΔF Range: -30 to 30 ΔF
	↓	RM.NO	XXX.X °F	REMOTE - NO RESET TEMP	Default: 125 F (51.7 C) Range: 0° to 125 F

Table 17 — Configuration Mode and Sub-Mode Directory (cont)

SUB-MODE	KEYPAD ENTRY	ITEM	DISPLAY	ITEM EXPANSION	COMMENT
RSET (cont)	↓	RM.F	XXX.X °F	REMOTE - FULL RESET TEMP	Default: 0.0° F (-17.8 C) Range: 0° to 125 F
	↓	RM.DG	XX.X °F	REMOTE - DEGREES RESET	Default: 0.0° F Range: -30 to 30 F
	↓	RT.NO	XXX.X ΔF	RETURN - NO RESET TEMP	Default: 10.0 ΔF (5.6 ΔC) Range: 0° to 125 F COOLER ΔT
	↓	RT.F	XXX.X ΔF	RETURN - FULL RESET TEMP	Default: 0.0 ΔF (0.0 ΔC) Range: 0° to 125 F COOLER ΔT
	↓	RT.DG	XX.X °F	RETURN - DEGREES RESET	Default: 0.0° F Range: -30 to 30 F (-34.4 to -1.1 C)
	↓	DMDC	X	DEMAND LIMIT SELECT	Default: None 0 = None 1 = Switch 2 = 4 to 20 mA Input 3 = CCN Loadshed
	↓	DM20	XXX %	DEMAND LIMIT AT 20 MA	Default: 100% Range: 0 to 100%
	↓	SHNM	XXX	LOADSHED GROUP NUMBER	Default: 0 Range: 0 to 99
	↓	SHDL	XXX %	LOADSHED DEMAND DELTA	Default: 0% Range: 0 to 60%
	↓	SHTM	XXX	MAXIMUM LOADSHED TIME	Default: 60 minutes Range: 0 to 120 minutes
	↓	DLS1	XXX %	DEMAND LIMIT SWITCH 1	Default: 80% Range: 0 to 100%
	↓	DLS2	XXX %	DEMAND LIMIT SWITCH 2	Default: 50% Range: 0 to 100%
	↓	LLEN	ENBL/DSBL	LEAD/LAG CHILLER ENABLE	Default: Disable
	↓	MSSL	SLVE/MAST	MASTER/SLAVE SELECT	Default: Master
	↓	SLVA	XXX	SLAVE ADDRESS	Default: 2 Range: 0 to 239
	ENTER	LLBL	X	LEAD/LAG BALANCE SELECT	Default: Master Leads 0 = Master Leads 1 = Slave Leads 2 = Automatic
	↓	LLBD	XXX	LEAD/LAG BALANCE DELTA	Default: 168 hours Range: 40 to 400 hours
	↓	LLDY	XXX	LAG START DELAY	Default: 5 minutes Range: 0 to 30 minutes
↓	PARA	YES	PARALLEL CONFIGURATION	Default: YES (CANNOT BE CHANGED)	
SLCT				SETPOINT AND RAMP LOAD	
	ENTER	CLSP	X	COOLING SETPOINT SELECT	Default: Single 0 = Single 1 = Dual Switch 2 = Dual CCN Occupied 3 = 4 to 20 mA Input (requires EMM)
	↓	RL.S	ENBL/DSBL	RAMP LOAD SELECT	Default: Enable
	↓	CRMP	X.X	COOLING RAMP LOADING	Default: 1.0 Range: 0.2 to 2.0
	↓	SCHD	XX	SCHEDULE NUMBER	Default: 1 Range: 1 to 99
↓	Z.GN	X.X	DEADBAND MULTIPLIER	Default: 2.0 Range: 1.0 to 4.0	
SERV				SERVICE CONFIGURATION	
	ENTER	EN.A1	ENBL/DSBL	ENABLE COMPRESSOR A1	Unit dependent
	↓	EN.A2	ENBL/DSBL	ENABLE COMPRESSOR A2	Unit dependent
	↓	EN.B1	ENBL/DSBL	ENABLE COMPRESSOR B1	Unit dependent
↓	EN.B2	ENBL/DSBL	ENABLE COMPRESSOR B2	Unit dependent	
BCST				BROADCAST CONFIGURATION	
	ENTER	T.D.BC	ON/OFF	CCN TIME/DATE BROADCAST	
	↓	OAT.B	ON/OFF	CCN OAT BROADCAST	
	↓	G.S.BC	ON/OFF	GLOBAL SCHEDULE BROADCAST	
↓	BC.AK	ON/OFF	CCN BROADCAST ACK'ER		

Table 18 — Time Clock Mode and Sub-Mode Directory

SUB-MODE	KEYPAD ENTRY	ITEM	DISPLAY	SUB-ITEM	DISPLAY	ITEM EXPANSION	COMMENT
TIME						TIME OF DAY	
	ENTER	HH.MM	XX.XX			HOUR AND MINUTE	Military (00:00 – 23:59)
DATE						MONTH,DATE,DAY AND YEAR	
	ENTER	MNTH	XX			MONTH OF YEAR	1-12 (1 = January, 2 = February, etc)
	↓	DOM	XX			DAY OF MONTH	Range: 01-31
	↓	DAY	X			DAY OF WEEK	1-7 (1 = Sunday, 2 = Monday, etc)
	↓	YEAR	XXXX			YEAR OF CENTURY	
DST						DAYLIGHT SAVINGS TIME	
	ENTER	STR.M	XX			MONTH	Default: 4, Range 1 – 12
	↓	STR.W	X			WEEK	Default: 1, Range 1 – 5
	↓	STR.D	X			DAY	Default: 7, Range 1 – 7
	↓	MIN.A	XX			MINUTES TO ADD	Default: 60, Range 0 – 99
	↓	STP.M	XX			MONTH	Default: 10, Range 1 – 12
	↓	STP.W	XX			WEEK	Default: 5, Range 1 – 5
	↓	STP.D	XX			DAY	Default: 7, Range 1 – 7
	↓	MIN.5	XX			MINUTES TO SUBTRACT	Default: 60, Range 0 – 99
SCH.N			XX			SCHEDULE NUMBER	Default: 1, Range 1 – 99
SCH.L						LOCAL OCCUPANCY SCHEDULE	
	ENTER	PER.1				OCCUPANCY PERIOD 1	
	ENTER			OCC.1	XX:XX	PERIOD OCCUPIED TIME	Military (00:00 – 23:59)
	↓			UNC.1	XX:XX	PERIOD UNOCCUPIED TIME	Military (00:00 – 23:59)
	↓			MON.1	YES/NO	MONDAY IN PERIOD	
	↓			TUE.1	YES/NO	TUESDAY IN PERIOD	
	↓			WED.1	YES/NO	WEDNESDAY IN PERIOD	
	↓			THU.1	YES/NO	THURSDAY IN PERIOD	
	↓			FRI.1	YES/NO	FRIDAY IN PERIOD	
	↓			SAT.1	YES/NO	SATURDAY IN PERIOD	
	↓			SUN.1	YES/NO	SUNDAY IN PERIOD	
	↓			HOL.1	YES/NO	HOLIDAY IN PERIOD	
	ENTER	PER.2				OCCUPANCY PERIOD 2	
	ENTER			OCC.2	XX:XX	PERIOD OCCUPIED TIME	Military (00:00 – 23:59)
	↓			UNC.2	XX:XX	PERIOD UNOCCUPIED TIME	Military (00:00 – 23:59)
	↓			MON.2	YES/NO	MONDAY IN PERIOD	
	↓			TUE.2	YES/NO	TUESDAY IN PERIOD	
	↓			WED.2	YES/NO	WEDNESDAY IN PERIOD	
	↓			THU.2	YES/NO	THURSDAY IN PERIOD	
	↓			FRI.2	YES/NO	FRIDAY IN PERIOD	
↓			SAT.2	YES/NO	SATURDAY IN PERIOD		
↓			SUN.2	YES/NO	SUNDAY IN PERIOD		
↓			HOL.2	YES/NO	HOLIDAY IN PERIOD		

Table 18 — Time Clock Mode and Sub-Mode Directory (cont)

SUB-MODE	KEYPAD ENTRY	ITEM	DISPLAY	SUB-ITEM	DISPLAY	ITEM EXPANSION	COMMENT	
SCH.L (cont)	ENTER	PER.3				OCCUPANCY PERIOD 3		
	ENTER			OCC.3	XX:XX	PERIOD OCCUPIED TIME	Military (00:00 – 23:59)	
	↓			UNC.3	XX:XX	PERIOD UNOCCUPIED TIME	Military (00:00 – 23:59)	
	↓			MON.3	YES/NO	MONDAY IN PERIOD		
	↓			TUE.3	YES/NO	TUESDAY IN PERIOD		
	↓			WED.3	YES/NO	WEDNESDAY IN PERIOD		
	↓			THU.3	YES/NO	THURSDAY IN PERIOD		
	↓			FRI.3	YES/NO	FRIDAY IN PERIOD		
	↓			SAT.3	YES/NO	SATURDAY IN PERIOD		
	↓			SUN.3	YES/NO	SUNDAY IN PERIOD		
	↓			HOL.3	YES/NO	HOLIDAY IN PERIOD		
	ENTER	PER.4					OCCUPANCY PERIOD 4	
	ENTER				OCC.4	XX:XX	PERIOD OCCUPIED TIME	Military (00:00 – 23:59)
	↓				UNC.4	XX:XX	PERIOD UNOCCUPIED TIME	Military (00:00 – 23:59)
	↓				MON.4	YES/NO	MONDAY IN PERIOD	
	↓				TUE.4	YES/NO	TUESDAY IN PERIOD	
	↓				WED.4	YES/NO	WEDNESDAY IN PERIOD	
	↓				THU.4	YES/NO	THURSDAY IN PERIOD	
	↓				FRI.4	YES/NO	FRIDAY IN PERIOD	
	↓				SAT.4	YES/NO	SATURDAY IN PERIOD	
	↓				SUN.4	YES/NO	SUNDAY IN PERIOD	
	↓				HOL.4	YES/NO	HOLIDAY IN PERIOD	
	ENTER	PER.5					OCCUPANCY PERIOD 5	
	ENTER				OCC.5	XX:XX	PERIOD OCCUPIED TIME	Military (00:00 – 23:59)
	↓				UNC.5	XX:XX	PERIOD UNOCCUPIED TIME	Military (00:00 – 23:59)
	↓				MON.5	YES/NO	MONDAY IN PERIOD	
	↓				TUE.5	YES/NO	TUESDAY IN PERIOD	
	↓				WED.5	YES/NO	WEDNESDAY IN PERIOD	
	↓				THU.5	YES/NO	THURSDAY IN PERIOD	
	↓				FRI.5	YES/NO	FRIDAY IN PERIOD	
	↓				SAT.5	YES/NO	SATURDAY IN PERIOD	
	↓				SUN.5	YES/NO	SUNDAY IN PERIOD	
	↓				HOL.5	YES/NO	HOLIDAY IN PERIOD	
	ENTER	PER.6					OCCUPANCY PERIOD 6	
	ENTER				OCC.6	XX:XX	PERIOD OCCUPIED TIME	Military (00:00 – 23:59)
	↓				UNC.6	XX:XX	PERIOD UNOCCUPIED TIME	Military (00:00 – 23:59)
	↓				MON.6	YES/NO	MONDAY IN PERIOD	
	↓				TUE.6	YES/NO	TUESDAY IN PERIOD	
	↓				WED.6	YES/NO	WEDNESDAY IN PERIOD	

Table 18 — Time Clock Mode and Sub-Mode Directory (cont)

SUB-MODE	KEYPAD ENTRY	ITEM	DISPLAY	SUB-ITEM	DISPLAY	ITEM EXPANSION	COMMENT	
SCH.L (cont)	↓			THU.6	YES/NO	THURSDAY IN PERIOD		
	↓			FRI.6	YES/NO	FRIDAY IN PERIOD		
	↓			SAT.6	YES/NO	SATURDAY IN PERIOD		
	↓			SUN.6	YES/NO	SUNDAY IN PERIOD		
	↓			HOL.6	YES/NO	HOLIDAY IN PERIOD		
	ENTER	PER.7				OCCUPANCY PERIOD 7		
	ENTER			OCC.7	XX:XX	PERIOD OCCUPIED TIME	Military (00:00 – 23:59)	
	↓			UNC.7	XX:XX	PERIOD UNOCCUPIED TIME	Military (00:00 – 23:59)	
	↓			MON.7	YES/NO	MONDAY IN PERIOD		
	↓			TUE.7	YES/NO	TUESDAY IN PERIOD		
	↓			WED.7	YES/NO	WEDNESDAY IN PERIOD		
	↓			THU.7	YES/NO	THURSDAY IN PERIOD		
	↓			FRI.7	YES/NO	FRIDAY IN PERIOD		
	↓			SAT.7	YES/NO	SATURDAY IN PERIOD		
	↓			SUN.7	YES/NO	SUNDAY IN PERIOD		
	↓			HOL.7	YES/NO	HOLIDAY IN PERIOD		
	ENTER	PER.8				OCCUPANCY PERIOD 8		
	ENTER			OCC.8	XX:XX	PERIOD OCCUPIED TIME	Military (00:00 – 23:59)	
	↓			UNC.8	XX:XX	PERIOD UNOCCUPIED TIME	Military (00:00 – 23:59)	
	↓			MON.8	YES/NO	MONDAY IN PERIOD		
	↓			TUE.8	YES/NO	TUESDAY IN PERIOD		
	↓			WED.8	YES/NO	WEDNESDAY IN PERIOD		
	↓			THU.8	YES/NO	THURSDAY IN PERIOD		
	↓			FRI.8	YES/NO	FRIDAY IN PERIOD		
	↓			SAT.8	YES/NO	SATURDAY IN PERIOD		
	↓			SUN.8	YES/NO	SUNDAY IN PERIOD		
	↓			HOL.8	YES/NO	HOLIDAY IN PERIOD		
	OVR						SCHEDULE OVERRIDE	
		ENTER	OVR.T	X			TIMED OVERRIDE HOURS	Default: 0, Range 0-4 hours
		↓	OVR.L	X			OVERRIDE TIME LIMIT	Default: 0, Range 0-4 hours
		↓	T.OVR	YES/NO			TIMED OVERRIDE	User Entry

Table 19 — Operating Mode and Sub-Mode Directory

SUB-MODE	KEYPAD ENTRY	ITEM	DISPLAY	ITEM EXPANSION	COMMENT
MODE				MODES CONTROLLING UNIT	
	ENTER	MD01	ON/OFF	FSM CONTROLLING CHILLER	
	↓	MD02	ON/OFF	WSM CONTROLLING CHILLER	
	↓	MD03	ON/OFF	MASTER/SLAVE CONTROL	
	↓	MD05	ON/OFF	RAMP LOAD LIMITED	
	↓	MD06	ON/OFF	TIMED OVERRIDE IN EFFECT	
	↓	MD07	ON/OFF	LOW COOLER SUCTION TEMPA	
	↓	MD08	ON/OFF	LOW COOLER SUCTION TEMPB	
	↓	MD09	ON/OFF	SLOW CHANGE OVERRIDE	
	↓	MD10	ON/OFF	MINIMUM OFF TIME ACTIVE	
	↓	MD13	ON/OFF	DUAL SETPOINT	
	↓	MD14	ON/OFF	TEMPERATURE RESET	
	↓	MD15	ON/OFF	DEMAND/SOUND LIMITED	
	↓	MD16	ON/OFF	COOLER FREEZE PROTECTION	
	↓	MD17	ON/OFF	LOW TEMPERATURE COOLING	
	↓	MD18	ON/OFF	HIGH TEMPERATURE COOLING	
	↓	MD19	ON/OFF	MAKING ICE	
	↓	MD20	ON/OFF	STORING ICE	
	↓	MD21	ON/OFF	HIGH SCT CIRCUIT A	
	↓	MD22	ON/OFF	HIGH SCT CIRCUIT B	
	↓	MD23	ON/OFF	MINIMUM COMP ON TIME	
	↓	MD24	ON/OFF	PUMP OFF DELAY TIME	
	↓	MD25	ON/OFF	LOW SOUND MODE	
	↓	MD26	ON/OFF	SHORT LOOP OVERRIDE	

LEGEND

- FSM — Flotronic™ System Manager
- SCT — Saturated Condensing Temperature
- WSM — Water System Manager

Table 20 — Alarms Mode and Sub-Mode Directory

SUB-MODE	KEYPAD ENTRY	ITEM	ITEM EXPANSION	COMMENT
CRNT	ENTER	AXXX OR TXXX	CURRENTLY ACTIVE ALARMS	Alarms are shown as AXXX. Alerts are shown as TXXX.
RCRN	ENTER	YES/NO	RESET ALL CURRENT ALARMS	
HIST	ENTER	AXXX OR TXXX	ALARM HISTORY	Alarms are shown as AXXX. Alerts are shown as TXXX.

Table 21 — Dual Chiller Configuration (Master Chiller Example)

SUB-MODE	ITEM	KEYPAD ENTRY	DISPLAY	ITEM EXPANSION	COMMENTS
DISP					
UNIT					
OPT1					
OPT2		ENTER	CTRL	CONTROL METHOD	
	CTRL	ENTER	0	SWITCH	DEFAULT 0
		ESCAPE	CTRL		
		ENTER	CCNA		
	CCNA	ENTER	1	CCN ADDRESS	DEFAULT 1
		ESCAPE	CCNA		
		↓	CCNB		
	CCNB	ENTER	0	CCN BUS NUMBER	DEFAULT 0
		ESCAPE	CCNB		
		ESCAPE	OPT2		
	↓	RSET		PROCEED TO SUBMODE RSET	
RSET		ENTER	CRST	COOLING RESET TYPE	
		↓	LLEN	LEAD/LAG CHILLER ENABLE	↓ 15 ITEMS
	LLEN	ENTER	DSBL		SCROLLING STOPS
		ENTER	DSBL		VALUE FLASHES
		↑	ENBL		SELECT ENBL
	LLEN	ENTER	ENBL	LEAD/LAG CHILLER ENABLE	CHANGE ACCEPTED
		ESCAPE	LLEN		
		↓	MSSL	MASTER /SLAVE SELECT	
	MSSL	ENTER	MAST	MASTER /SLAVE SELECT	DEFAULT MAST
		ESCAPE	MSSL		
		↓	SLVA	SLAVE ADDRESS	
	SLVA	ENTER	0		SCROLLING STOPS
		ENTER	0		VALUE FLASHES
		↑	2		SELECT 2
	SLVA	ENTER	2	SLAVE ADDRESS	CHANGE ACCEPTED
		ESCAPE	SLVA		
		↓	LLBL	LEAD/LAG BALANCE SELECT	
LLBL	ENTER	0		SCROLLING STOPS	
	ENTER	0		VALUE FLASHES	
	↑	2		SELECT 2 - Automatic	

Table 21 — Dual Chiller Configuration (Master Chiller Example) (cont)

SUB-MODE	ITEM	KEYPAD ENTRY	DISPLAY	ITEM EXPANSION	COMMENTS
RSET	LLBL	<input type="button" value="ENTER"/>	2	LEAD/LAG BALANCE SELECT	CHANGE ACCEPTED
		<input type="button" value="ESCAPE"/>	LLBL		
		<input type="button" value="↓"/>	LLBD	LEAD/LAG BALANCE DELTA	
	LLBD	<input type="button" value="ENTER"/>	168	LEAD/LAG BALANCE DELTA	DEFAULT 168
		<input type="button" value="ESCAPE"/>	LLBD		
		<input type="button" value="↓"/>	LLDY	LAG START DELAY	
	LLDY	<input type="button" value="ENTER"/>	5		SCROLLING STOPS
		<input type="button" value="ENTER"/>	5		VALUE FLASHES
		<input type="button" value="↑"/>	10		SELECT 10
	LLDY	<input type="button" value="ENTER"/>	10	LAG START DELAY	CHANGE ACCEPTED
		<input type="button" value="ESCAPE"/>	LLDY		
		<input type="button" value="ESCAPE"/>	RSET		
	PARA	<input type="button" value="ENTER"/>	YES		MASTER COMPLETE

NOTES:

1. Master Control Method (CTRL) can be configured as 0-Switch, 2-Occupancy or 3-CCN.
2. Parallel Configuration (PARA) cannot be changed.

Table 22 — Dual Chiller Configuration (Slave Chiller Example)

SUB-MODE	ITEM	KEYPAD ENTRY	DISPLAY	ITEM EXPANSION	COMMENTS
DISP					
UNIT					
OPT1					
OPT2		ENTER	CTRL	CONTROL METHOD	
	CTRL		0	SWITCH	DEFAULT 0
		ESCAPE	CTRL		
	CTRL	↓	CCNA		
	CCNA	ENTER	1	CCN ADDRESS	SCROLLING STOPS
		ENTER	1		VALUE FLASHES
		↑	2		SELECT 2 (SEE NOTE 1)
	CCNA	ENTER	2	CCN ADDRESS	CHANGE ACCEPTED
		ESCAPE	CCNA		
		↓	CCNB		
	CCNB	ENTER	0	CCN BUS NUMBER	DEFAULT 0 (SEE NOTE 2)
		ESCAPE	CCNB		
		ESCAPE	OPT2		
		↓	RSET		PROCEED TO SUBMODE RSET
	RSET		ENTER	CRST	COOLING RESET TYPE
		↓	LLEN	LEAD/LAG CHILLER ENABLE	↓ 15 ITEMS
LLEN		ENTER	DSBL		SCROLLING STOPS
		ENTER	DSBL		VALUE FLASHES
		↑	ENBL		SELECT ENBL
LLEN		ENTER	ENBL	LEAD/LAG CHILLER ENABLE	CHANGE ACCEPTED
		ESCAPE	LLEN		
		↓	MSSL	MASTER /SLAVE SELECT	
MSSL		ENTER	MAST		SCROLLING STOPS
		ENTER	MAST		VALUE FLASHES
		↑	SLVE		SELECT SLVE
MSSL		ENTER	SLVE	MASTER /SLAVE SELECT	CHANGE ACCEPTED
		ESCAPE	MSSL		
		ESCAPE	RSET		SLAVE COMPLETE

NOTES:

1. Slave Control Method (CTRL) must be configured for 0.
2. Slave CCN Address (CCNA) must be different than Master.
3. Slave CCN Bus Number (CCNB) must be the same as Master
4. Slave does not require SLVA, LLBL, LLBD, or LLDY to be configured.

Table 23 — Operating Modes

MODE NO.	ITEM EXPANSION	DESCRIPTION
01	FSM CONTROLLING CHILLER	Flotronic™ System Manager (FSM) is controlling the chiller.
02	WSM CONTROLLING CHILLER	Water System Manager (WSM) is controlling the chiller.
03	MASTER/SLAVE CONTROL	Dual Chiller control is enabled.
05	RAMP LOAD LIMITED	Ramp load (pull-down) limiting in effect. In this mode, the rate at which leaving fluid temperature is dropped is limited to a predetermined value to prevent compressor overloading. See Cooling Ramp Loading (CRMP) [Configuration, SLCT]. The pull-down limit can be modified, if desired, to any rate from 0.2° F to 2° F (0.1° to 1° C)/minute.
06	TIMED OVERRIDE IN EFFECT	Timed override is in effect. This is a 1 to 4 hour temporary override of the programmed schedule, forcing unit to Occupied mode. Override can be implemented with unit under Local (Enable) or CCN (Carrier Comfort Network) control. Override expires after each use.
07	LOW COOLER SUCTION TEMPA	Circuit A cooler Freeze Protection mode. At least one compressor must be on, and the Saturated Suction Temperature is not increasing greater than 1.1° F (0.6° C) in 10 seconds. If the saturated suction temperature is less than the Brine Freeze Point (BR.FZ) [Set Point, FRZ] minus 3° F (1.7° C) and less than the leaving fluid temperature minus 14° F (7.8° C) for 2 minutes, a stage of capacity will be removed from the circuit. Or, If the saturated suction temperature is less than the Brine Freeze Point (BR.FZ) [Set Point, FRZ] minus 14° F (7.8° C), for 90 seconds, a stage of capacity will be removed from the circuit. The control will continue to decrease capacity as long as either condition exists.
08	LOW COOLER SUCTION TEMPB	Circuit B cooler Freeze Protection mode. At least one compressor must be on, and the Saturated Suction Temperature is not increasing greater than 1.1° F (0.6° C) in 10 seconds. If the saturated suction temperature is less than the Brine Freeze Point (BR.FZ) [Set Point, FRZ] minus 3° F (1.7° C) and less than the leaving fluid temperature minus 14° F (7.8° C) for 2 minutes, a stage of capacity will be removed from the circuit. Or, If the saturated suction temperature is less than the Brine Freeze Point (BR.FZ) [Set Point, FRZ] minus 14° F (7.8° C), for 90 seconds, a stage of capacity will be removed from the circuit. The control will continue to decrease capacity as long as either condition exists.
09	SLOW CHANGE OVERRIDE	Slow change override is in effect. The leaving fluid temperature is close to and moving towards the control point.
10	MINIMUM OFF TIME ACTIVE	Chiller is being held off by Minutes Off Time (DELY) [Configuration, OPT2].
13	DUAL SETPOINT	Dual Set Point mode is in effect. Chiller controls to Cooling Set Point 1 (CSP.1) [Set Point, COOL] during occupied periods and Cooling Set Point 2 (CSP.2) [Set Point, COOL] during unoccupied periods.
14	TEMPERATURE RESET	Temperature reset is in effect. In this mode, chiller is using temperature reset to adjust leaving fluid set point upward and is currently controlling to the modified set point. The set point can be modified based on return fluid, outdoor-air-temperature, space temperature, or 4 to 20 mA signal.
15	DEMAND/SOUND LIMITED	Demand limit is in effect. This indicates that the capacity of the chiller is being limited by demand limit control option. Because of this limitation, the chiller may not be able to produce the desired leaving fluid temperature. Demand limit can be controlled by switch inputs or a 4 to 20 mA signal.
16	COOLER FREEZE PROTECTION	Cooler fluid temperatures are approaching the Freeze point (see Alarms and Alerts section for definition). The chiller will be shut down when either fluid temperature falls below the Freeze point.
17	LOW TEMPERATURE COOLING	Chiller is in Cooling mode and the rate of change of the leaving fluid is negative and decreasing faster than -0.5° F per minute. Error between leaving fluid and control point exceeds fixed amount. Control will automatically unload the chiller if necessary.
18	HIGH TEMPERATURE COOLING	Chiller is in Cooling mode and the rate of change of the leaving fluid is positive and increasing. Error between leaving fluid and control point exceeds fixed amount. Control will automatically load the chiller if necessary to better match the increasing load.
19	MAKING ICE	Chiller is in an unoccupied mode and is using Cooling Set Point 3 (CSP.3) [Set Point, COOL] to make ice. The ice done input to the Energy Management Module (EMM) is open.
20	STORING ICE	Chiller is in an unoccupied mode and is controlling to Cooling Set Point 2 (CSP.2) [Set Point COOL]. The ice done input to the Energy Management Module (EMM) is closed.
21	HIGH SCT CIRCUIT A	Chiller is in a Cooling mode and the Saturated Condensing Temperature (SCT) is greater than the calculated maximum limit. No additional stages of capacity will be added. Chiller capacity may be reduced if SCT continues to rise to avoid high-pressure switch trips by reducing condensing temperature.
22	HIGH SCT CIRCUIT B	Chiller is in a Cooling mode and the Saturated Condensing Temperature (SCT) is greater than the calculated maximum limit. No additional stages of capacity will be added. Chiller capacity may be reduced if SCT continues to rise to avoid high-pressure switch trips by reducing condensing temperature.
23	MINIMUM COMP ON TIME	Cooling load may be satisfied, however control continues to operate compressor to ensure proper oil return. May be an indication of oversized application, low fluid flow rate or low loop volume.
24	PUMP OFF DELAY TIME	Cooling load is satisfied, however cooler pump continues to run for the number of minutes set by the configuration variable Cooler Pump Shutdown Delay (PM.DY) [Configuration, OPT1].
25	LOW SOUND MODE	Chiller operates at higher condensing temperature and/or reduced capacity to minimize overall unit noise during evening/night hours (user-configurable).
26	SHORT LOOP OVERRIDE	Chiller is monitoring how fast compressor(s) is being cycled to maintain the desired leaving fluid temperature. Control is limiting the rate of compressor cycling when this mode is active to ensure proper oil return and also to prevent premature compressor failure. Low loop volume, low cooler flow and/or low chiller load are the primary causes for this mode.

Table 24 — Example of Reading and Clearing Alarms

SUB-MODE	KEYPAD ENTRY	ITEM	ITEM EXPANSION	COMMENT
CRNT		AXXX or TXXX	CURRENTLY ACTIVE ALARMS	ACTIVE ALARMS (AXXX) OR ALERTS (TXXX) DISPLAYED.
CRNT				
RCRN		NO		Use to clear active alarms/alerts
		NO		NO Flashes
		YES		Select YES
		NO		Alarms/alerts clear, YES changes to NO

Table 25A — 4-20 mA Reset

SUB-MODE	KEYPAD ENTRY	ITEM	DISPLAY	ITEM EXPANSION	COMMENT
RSET		CRST	1	COOLING RESET TYPE	0 = no reset 1 = 4 to 20 mA input 2 = Outdoor air temp 3 = Return Fluid 4 = Space Temperature
		CRT1	4.0	NO COOL RESET TEMP	Default: 125 F (51.7 C) Range: 0° to 125 F
		CRT2	20.0	FULL COOL RESET TEMP	Default: 0° F (-17.8 C) Range: 0° to 125 F
		DGRC	5.0 F (2.8 C)	DEGREES COOL RESET	Default: 0° F (0° C) Reset at 20 mA Range: -30 to 30 F (-16.7 to 16.7 C)

NOTE: The example above shows how to configure the chiller for 4-20 mA reset. No reset will occur at 4.0 mA input, and a 5.0 F reset will occur at 20.0 mA. An EMM is required.

Table 25B — Menu Configuration of 4 to 20 mA Cooling Set Point Control

MODE (RED LED)	KEYPAD ENTRY	SUB-MODE	KEYPAD ENTRY	ITEM	DISPLAY	ITEM EXPANSION	COMMENT
CONFIGURATION		DISP					
		UNIT					
		OPT1					
		OPT2					
		RSET					
		SLCT		CLSP	0	COOLING SETPOINT SELECT	
					0		Scrolling Stops
					0		Flashing '0'
					4		Select '4'
					4		Change Accepted

Table 26A — Configuring Outdoor Air and Space Temperature Reset

MODE (RED LED)	KEYPAD ENTRY	SUB-MODE	KEYPAD ENTRY	ITEM	DISPLAY		ITEM EXPANSION	COMMENT
					Outdoor Air	Space		
CONFIGURATION	ENTER	DISP						
	▼	UNIT						
	▼	OPT1						
	▼	OPT2						
	▼	RSET	ENTER	CRST	2	4	COOLING RESET TYPE	2 = Outdoor-Air Temperature 4 = Space Temperature (Connect to TB5-5,6)
			▼	RM.NO*	85 °F	72 °F	REMOTE - NO RESET TEMP	Default: 125.0 F (51.7 C) Range: 0° to 125 F
			▼	RM.F	55 °F	68 °F	REMOTE - FULL RESET TEMP	Default: 0.0° F (-17.7 C) Range: 0° to 125 F
		▼	RM.DG	15 °F	6 °F	REMOTE - DEGREES RESET	Default: 0° F (0° C) Range: -30 to 30 F (-34.4 to -1.1 °C)	

*4 items skipped in this example.

Table 26B — Configuring Return Temperature Reset

MODE (RED LED)	KEYPAD ENTRY	SUB-MODE	KEYPAD ENTRY	ITEM	DISPLAY	ITEM EXPANSION	COMMENT
CONFIGURATION	ENTER	DISP	ENTER	TEST	ON/OFF	TEST DISPLAY LEDs	
	▼	UNIT	ENTER	TYPE	X	UNIT TYPE	
	▼	OPT1	ENTER	FLUD	X	COOLER FLUID	
	▼	OPT2	ENTER	CTRL	X	CONTROL METHOD	
	▼	RSET	ENTER	CRST	X	COOLING RESET TYPE	0 = No Reset 1 = 4 to 20 mA Input (EMM required) (Connect to EMM TB6-2,3) 2 = Outdoor-Air Temperature 3 = Return Fluid 4 = Space Temperature (Connect to TB5-5,6)
			▼	RT.NO*	XXX.X ΔF	RETURN FLUID - NO RESET TEMP	Default: 10.0 ΔF (5.6 ΔC) Range: 0° to 125 F COOLER ΔT
			▼	RT.F	XXX.X ΔF	RETURN FLUID - FULL RESET TEMP	Default: 0 ΔF (-17.8 ΔC) Range: 0° to 125 F COOLER ΔT
		▼	RT.DG	XX.X ΔF	RETURN - DEGREES RESET	Default: 0 ΔF (0 ΔC) Range: -30 to 30°F (-16.7 to 16.7 C)	

*4 items skipped in this example.

Temperature Reset — The control system is capable of handling leaving-fluid temperature reset based on return cooler fluid temperature. Because the change in temperature through the cooler is a measure of the building load, the return temperature reset is in effect an average building load reset method. The control system is also capable of temperature reset based on outdoor-air temperature (OAT), space temperature (SPT), or from an externally powered 4 to 20 mA signal. Accessory sensors must be used for SPT reset (33ZCT55SPT). The Energy Management Module (EMM) must be used for temperature reset using a 4 to 20 mA signal. See Tables 25A and 25B.

IMPORTANT: Care should be taken when interfacing with other control systems due to possible power supply differences: full wave bridge versus half wave rectification. Connection of control devices with different power supplies may result in permanent damage. *ComfortLink™* controls incorporate power supplies with half wave rectification. A signal isolation device should be utilized if the signal generator incorporates a full wave bridge rectifier.

To use Outdoor Air or Space Temperature reset, four variables must be configured. In the Configuration mode under the sub-mode RSET, items CRST, RM.NO, RM.F and RT.DG must be properly set. See Table 26A — Configuring Outdoor Air and Space Temperature Reset. The outdoor air reset example provides 0° F (0° C) chilled water set point reset at 85.0 F (29.4 C) outdoor-air temperature and 15.0 F (8.3 C) reset at 55.0 F (12.8 C) outdoor-air temperature. The space temperature reset example provides 0° F (0° C) chilled water set point reset at 72.0 F (22.2 C) space temperature and 6.0 F (3.3 C) reset at 68.0 F (20.0 C) space temperature. The variable CRST should be configured for the type of reset desired. The variable RM.NO should be set to the temperature that no reset should occur. The variable RM.F should be set to the temperature that maximum reset is to occur. The variable RM.DG should be set to the maximum amount of reset desired.

To use Return reset, four variables must be configured. In the Configuration mode under the sub-mode RSET, items CRST, RT.NO, RT.F and RT.DG must be properly set. See Table 26B — Configuring Return Temperature Reset. This example provides 5.0 F (2.8 C) chilled water set point reset at

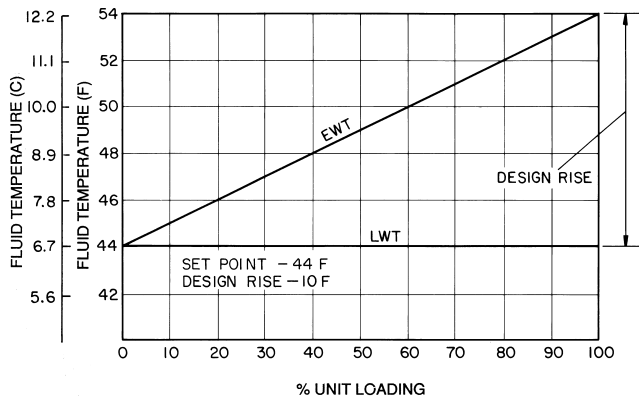
2.0 F (1.1 C) cooler ΔT and 0° F (0° C) reset at 10.0 F (5.6 C) cooler ΔT . The variable RT.NO should be set to the cooler temperature difference (ΔT) where no chilled water temperature reset should occur. The variable RT.F should be set to the cooler temperature difference where the maximum chilled water temperature reset should occur. The variable RM.DG should be set to the maximum amount of reset desired.

To verify that reset is functioning correctly proceed to Run Status mode, sub-mode VIEW, and subtract the active set point (SETP) from the control point (CTPT) to determine the degrees reset.

Under normal operation, the chiller will maintain a constant leaving fluid temperature approximately equal to the chilled fluid set point. As the cooler load varies, the entering cooler fluid will change in proportion to the load as shown in Fig. 18. Usually the chiller size and leaving-fluid temperature set point are selected based on a full-load condition. At part load, the fluid temperature set point may be colder than required. If the leaving fluid temperature was allowed to increase at part load, the efficiency of the machine would increase.

Return temperature reset allows for the leaving temperature set point to be reset upward as a function of the return fluid temperature or, in effect, the building load.

Figures 19 and 20 are examples of outdoor air and space temperature resets.



LEGEND

- EWT — Entering Water (Fluid) Temperature
- LWT — Leaving Water (Fluid) Temperature

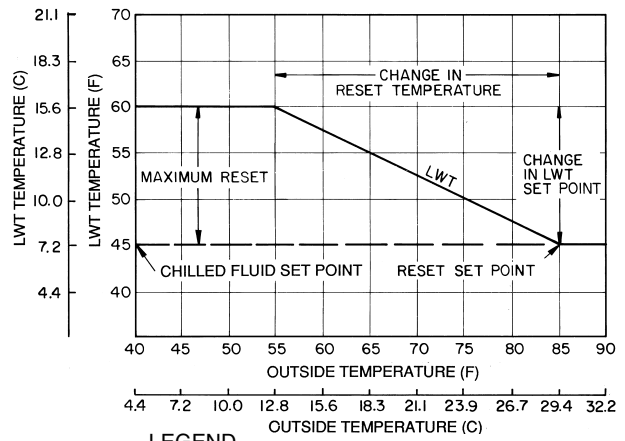
Fig. 18 — Standard Chilled Fluid Temperature Control — No Reset

Demand Limit — Demand Limit is a feature that allows the unit capacity to be limited during periods of peak energy usage. There are 3 types of demand limiting that can be configured. The first type is through 2-stage switch control, which will reduce the maximum capacity to 2 user-configurable percentages. The second type is by 4 to 20 mA signal input which will reduce the maximum capacity linearly between 100% at a 4 mA input signal (no reduction) down to the user-configurable level at a 20 mA input signal. The third type uses the CNN Loadshed module and has the ability to limit the current operating capacity to maximum and further reduce the capacity if required.

NOTE: The 2-stage switch control and 4- to 20-mA input signal types of demand limiting require the Energy Management Module (EMM).

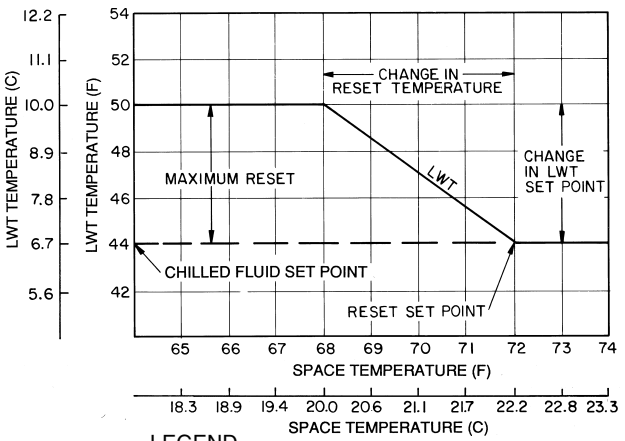
To use Demand Limit, select the type of demand limiting to use. Then configure the Demand Limit set points based on the type selected.

DEMAND LIMIT (2-Stage Switch Controlled) — To configure Demand Limit for 2-stage switch control set the Demand Limit Select (DMDC) [Configuration, RSET] to 1. Then



- LWT — Leaving Water (Fluid) Temperature

Fig. 19 — Outdoor-Air Temperature Reset



- LWT — Leaving Water (Fluid) Temperature

Fig. 20 — Space Temperature Reset

configure the 2 Demand Limit Switch points (DLS1 and DLS2) [Configuration, RSET] to the desired capacity limit. See Table 27. Capacity steps are controlled by 2 relay switch inputs field wired to TB6 as shown in Fig. 4-6.

For Demand Limit by 2-stage switch control, closing the first stage demand limit contact will put the unit on the first demand limit level. The unit will not exceed the percentage of capacity entered as Demand Limit Switch 1 set point. Closing contacts on the second demand limit switch prevents the unit from exceeding the capacity entered as Demand Limit Switch 2 set point. The demand limit stage that is set to the lowest demand takes priority if both demand limit inputs are closed. If the demand limit percentage does not match unit staging, the unit will limit capacity to the closest capacity stage.

To disable demand limit configure the DMDC to 0. See Table 27.

EXTERNALLY POWERED DEMAND LIMIT (4 to 20 mA Controlled) — To configure Demand Limit for 4 to 20 mA control set the Demand Limit Select (DMDC) [Configuration, RSET] to 2. Then configure the Demand Limit at 20 mA (DM20) [Configuration, RSET] to the maximum loadshed value desired. Connect the output from an externally powered 4 to 20 mA signal to terminal block TB6, terminals 1 and 5. Refer to the unit wiring diagram for these connections to the optional/accessory Energy Management Module and terminal block. The control will reduce allowable capacity to this level for the 20 mA signal. See Table 27 and Fig. 21A.

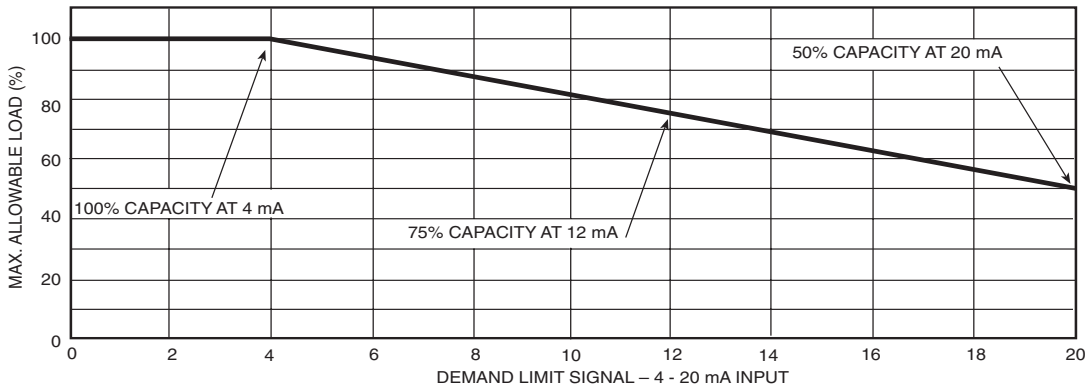


Fig. 21A — 4- to 20-mA Demand Limiting

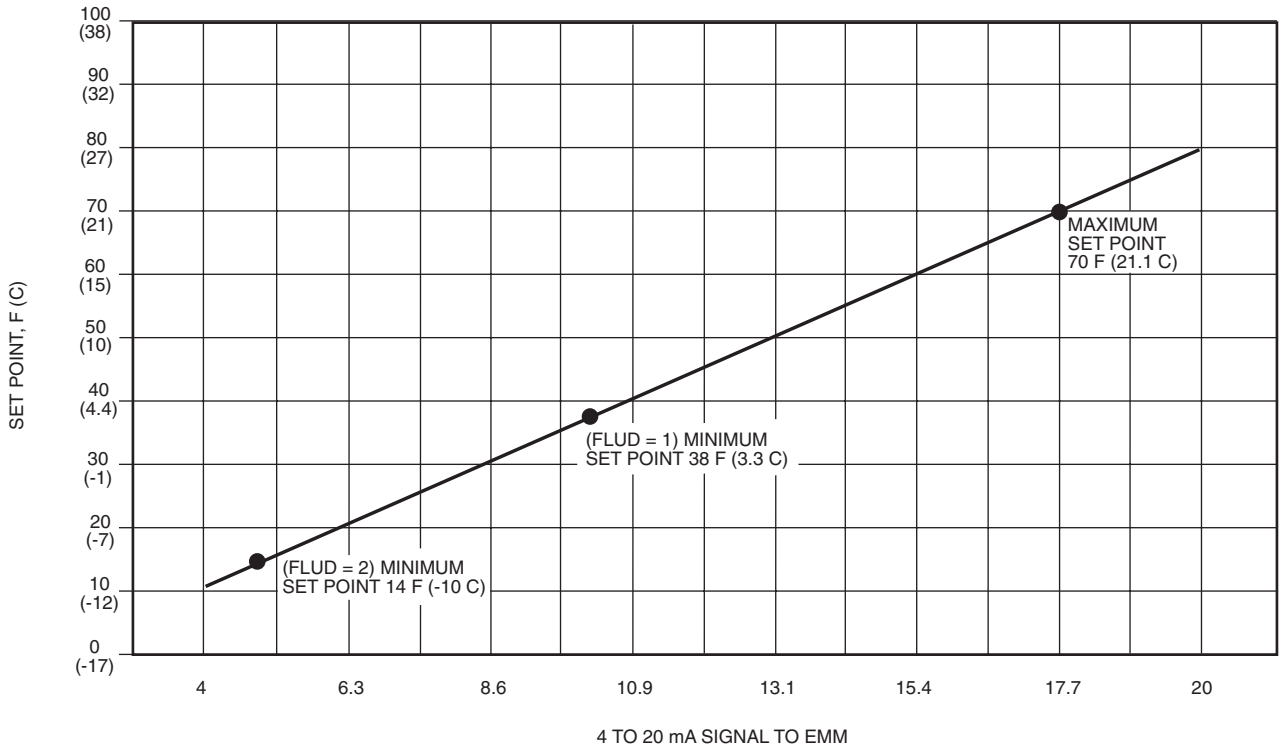
⚠ CAUTION
 Care should be taken when interfacing with other manufacturer’s control systems, due to possible power supply differences, full wave bridge versus half wave rectification. The two different power supplies cannot be mixed. *ComfortLink*™ controls use half wave rectification. A signal isolation device should be utilized if a full wave bridge signal generating device is used.

DEMAND LIMIT (CCN Loadshed Controlled) — To configure Demand Limit for CCN Loadshed control set the Demand Limit Select (DMDC) [Configuration, RSET] to 3. Then configure the Loadshed Group Number (SHNM), Loadshed Demand Delta (SHDL), and Maximum Loadshed Time (SHTM) [Configuration, RSET]. See Table 27.

The Loadshed Group number is established by the CCN system designer. The *ComfortLink* control will respond to a Redline command from the Loadshed control. When the

Redline command is received, the current stage of capacity is set to the maximum stages available. Should the loadshed control send a Loadshed command, the *ComfortLink* control will reduce the current stages by the value entered for Loadshed Demand delta. The Maximum Loadshed Time is the maximum length of time that a loadshed condition is allowed to exist. The control will disable the Redline/Loadshed command if no Cancel command has been received within the configured maximum loadshed time limit.

Cooling Set Point (4 to 20 mA) — A field supplied and generated, externally powered 4 to 20 mA signal can be used to provide the leaving fluid temperature set point. Connect the signal to TB6-3,5 (+,-). See Table 27 for instructions to enable the function. Figure 21B shows how the 4 to 20 mA signal is linearly calculated on an overall 10 F to 80 F range for fluid types (FLUD) 1 or 2 [Configuration, OPT1]. The set point will be limited by the fluid (FLUD) type. Be sure that the chilled water loop is protected at the lowest temperature.



EMM — Energy Management Module

Fig. 21B — Cooling Set Point (4 to 20 mA)

Table 27 — Configuring Demand Limit

MODE	KEYPAD ENTRY	SUB-MODE	KEYPAD ENTRY	ITEM	DISPLAY	ITEM EXPANSION	COMMENT
CONFIGURATION	ENTER	DISP	ENTER	TEST	ON/OFF	Test Display LEDs	
	▼	UNIT	ENTER	TYPE	X	Unit Type	
	▼	OPT1	ENTER	FLUD	X	Cooler Fluid	
	▼	OPT2	ENTER	CTRL	X	Control Method	
	▼	RSET	ENTER	CRST	X	Cooling Reset Type	
			▼	DMDC*	X	Demand Limit Select	Default: 0 0 = None 1 = Switch 2 = 4 to 20 mA Input 3 = CCN Loadshed
			▼	DM20	XXX %	Demand Limit at 20 mA	Default: 100% Range: 0 to 100
			▼	SHNM	XXX	Loadshed Group Number	Default: 0 Range: 0 to 99
			▼	SHDL	XXX%	Loadshed Demand Delta	Default: 0% Range: 0 to 60%
			▼	SHTM	XXX MIN	Maximum Loadshed Time	Default: 60 min. Range: 0 to 120 min.
			▼	DLS1	XXX %	Demand Limit Switch 1	Default: 80% Range: 0 to 100%
			▼	DLS2	XXX %	Demand Limit Switch 2	Default: 50% Range: 0 to 100%

*Seven items skipped in this example.

TROUBLESHOOTING

Complete Unit Stoppage and Restart — Possible causes for unit stoppage and reset methods are shown below. (See Table 28 also.) Refer to Fig. 22-26 for Component Arrangement and Control Wiring Diagrams.

GENERAL POWER FAILURE — After power is restored, restart is automatic through normal MBB start-up.

UNIT ENABLE-OFF-REMOTE CONTACT SWITCH IS OFF — When the switch is OFF, the unit will stop immediately. Place the switch in the ENABLE position for local switch control or in the REMOTE CONTACT position for control through remote contact closure.

CHILLED FLUID PROOF-OF-FLOW SWITCH OPEN — After the problem causing the loss of flow has been corrected, reset is manual by resetting the alarm with the Scrolling Marquee as shown in Table 24.

OPEN HIGH-PRESSURE SWITCH(ES) — Determine and correct the cause of the failure. The switch automatically resets, but the unit must be reset manually by resetting the alarm with the Scrolling Marquee as shown in Table 24.

OPEN COMPRESSOR INTERNAL THERMAL PROTECTION — This switch provides compressor over temperature protection. Determine and correct the cause of the problem. The switch resets automatically, but the unit must be reset manually resetting the alarm with the Scrolling Marquee as shown in Table 24.

OPEN 24-V CONTROL CIRCUIT BREAKER(S) — Determine the cause of the failure and correct. Reset circuit breaker(s). Restart is automatic after MBB start-up cycle is complete.

COOLING LOAD SATISFIED — Unit shuts down when cooling load has been satisfied. Unit restarts when required to satisfy leaving fluid temperature set point.

THERMISTOR FAILURE — If a thermistor fails in either an open or shorted condition, the unit will be shut down. Replace T1, T2, or T9 as required. Unit restarts automatically, but must be reset manually by resetting the alarm with the Scrolling Marquee as shown in Table 24.

⚠ CAUTION

If unit stoppage occurs more than once as a result of any of the safety devices listed, determine and correct cause before attempting another restart.

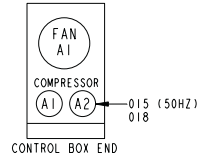
LOW SATURATED SUCTION — Several conditions can lead to low saturated suction alarms and the chiller controls have several override modes built in which will attempt to keep the chiller from shutting down. Low fluid flow, low refrigerant charge and plugged filter driers are the main causes for this condition. To avoid permanent damage and potential freezing of the system, do NOT repeatedly reset these alert and/or alarm conditions without identifying and correcting the cause(s).

Table 28 — Troubleshooting

SYMPTOMS	CAUSE	REMEDY	
Cooler Circulating Pump Does Not Run	Power line open	Reset circuit breaker.	
	Control fuse or circuit breaker open	Check control circuit for ground or short. Reset breaker and replace fuse.	
	Compressor over temperature sensor open (06D)	Find cause of high temperature and reset controls.	
	Tripped power breaker	Check the controls. Find the cause of trip and reset breaker.	
	Cooler circulating pump not running	Power off — restart.	
		Pump binding — free pump.	
		Incorrect wiring —rewire.	
		Pump motor burned out — replace.	
	Loose terminal connection	Check connections.	
	Improperly wired controls	Check wiring and rewire if necessary.	
	Low line voltage	Check line voltage — determine location of voltage drop and remedy deficiency.	
Compressor motor defective	Check motor winding for open or short. Replace compressor if necessary.		
Seized compressor	Replace compressor.		
Compressor Cycles Off on Loss of Charge	Loss of charge control erratic in action	Repair leak and recharge.	
		Replace control.	
	Low refrigerant charge	Add refrigerant.	
Low suction temperature	Raise cooler leaving fluid temperature set point.		
Compressor Cycles Off on Out of Range Condition	Thermistor failure	Replace thermistor.	
	System load was reduced faster than controller could remove stages	Unit will restart after fluid temperature rises back into the control band. Avoid rapidly removing system load.	
	Temperature controller deadband setting is too low	Raise deadband setting.	
Compressor Shuts Down on High-Pressure Control	High-pressure control acting erratically	Replace control.	
	Compressor discharge valve partially closed	Open valve or replace (if defective).	
	Noncondensables in system	Purge system.	
	Condenser scaled/dirty	Clean condenser.	
	Condenser water pump or fans not operating	Start pump — repair or replace if defective.	
	System overcharged with refrigerant	Reduce charge.	
Unit Operates Too Long or Continuously	Low refrigerant charge	Add refrigerant.	
	Control contacts fused	Replace control.	
	Air in system	Purge system.	
	Partially plugged or plugged expansion valve or filter drier	Clean or replace as needed.	
	Defective insulation	Replace or repair as needed.	
	Service load	Keep doors and windows closed.	
	Inefficient compressor	Check valves, and replace if necessary.	
Unusual or Loud System Noises	Piping vibration	Support piping as required.	
		Check for loose pipe connections	
	Expansion valve hissing	Add refrigerant.	
		Check for plugged liquid line filter drier.	
	Compressor noisy	Replace compressor (worn bearings).	
Check for loose compressor holddown bolts.			
Compressor Loses Oil	Leak in system	Repair leak.	
	Mechanical damage (Failed seals or broken scrolls)	Replace compressor.	
	Oil trapped in line	Check piping for oil traps.	
Hot Liquid Line	Shortage of refrigerant due to leak	Repair leak and recharge.	
Frosted Liquid Line	Shutoff valve partially closed or restricted	Open valve or remove restriction.	
	Restricted filter drier	Replace filter drier.	
Frosted Suction Line	Expansion valve admitting excess refrigerant (note: this is a normal condition for brine applications)	Adjust expansion valve. Replace valve if defective.	
Freeze-Up	Improper charging	Make sure a full quantity of fluid is flowing through the cooler while charging, and suction pressure in cooler is equal to or greater than pressure corresponding to 32 F (0° C) (58 psig [400 kPa] for Refrigerant 22).	
	System not drained for winter shutdown	<i>Recommended that system be filled with an appropriate glycol mixture to prevent freezing of pumps and fluid tubing.</i>	
	Loose Thermistor	Verify thermistors are fully inserted in wells.	

- LEGEND**
- C** — Contactor, Compressor
 - CB** — Circuit Breaker
 - CHC** — Cooler/Pump Heater Contactor
 - CWP** — Chilled Water Pump
 - EMM** — Energy Management
 - FC** — Fan Contactor
 - FIOP** — Factory-Installed Option
 - FU** — Fuse
 - GND** — Ground
 - MBB** — Main Base Board
 - MM** — Motormaster®
 - MMPT** — Motormaster Pressure Transducer
 - MS** — Manual Starter
 - NEC** — National Electrical Code
 - SW** — Switch
 - TB** — Terminal Block
 - TRAN** — Transformer
- Factory Wiring
 - - - - - Field Wiring
 - · - · - Accessory or Option Wiring

LOW AMBIENT OPERATION (MOTORMASTER V) FIOP/ACCESSORY		
UNIT VOLTAGE	CONFIGURATION JUMPER LOCATION	CONFIGURATION JUMPER COMMON LOCATION
575-3-60	I	2
380-3-60	13A	
230-3-60	I	
208-3-60	13A	
460-3-60	I	
230-3-50	13B	
380/415-3-50	13C	



- NOTES:**
- FACTORY WIRING IS IN ACCORDANCE WITH UL 1995 STANDARDS. ANY FIELD MODIFICATIONS OR ADDITIONS MUST BE IN COMPLIANCE WITH ALL APPLICABLE CODES.
 - USE 75°C MIN WIRE FOR FIELD POWER SUPPLY.
 - ALL COMPRESSOR MANUAL STARTERS "MUST TRIP AMPS" ARE EQUAL TO OR LESS THAN 156% FLA. ALL OTHER MANUAL STARTERS "MUST TRIP AMPS" ARE EQUAL TO OR LESS THAN 140% FLA.
 - ALL FIELD INTERLOCK CONTACTS MUST HAVE A MIN RATING OF 2 AMPS @ 24VAC. SEE FIELD INTERLOCK WIRING.
 - COMPRESSOR AND FAN MOTORS ARE THERMALLY PROTECTED - THREE PHASE MOTORS PROTECTED AGAINST PRIMARY SINGLE PHASE CONDITIONS.
 - INTERCHANGE FAN MOTOR CONNECTIONS 1 AND 3 TO ENSURE COUNTER CLOCKWISE FAN ROTATION.
 - TERMINALS 9 & 10 OF TB5 ARE FOR FIELD CONNECTION OF REMOTE ON-OFF. THE CONTACT MUST BE RATED FOR DRY CIRCUIT APPLICATION CAPABLE OF HANDLING A 5VDC 1 MA TO 20 MA LOAD.
 - COMPRESSORS ON MODELS 015 (50 HZ) AND 018 ARE PROTECTED BY INTERNAL LINE BREAK DEVICES NOT THERMOSTATS.
 - ALARM RELAY MUST BE INSTALLED FOR HEATING/BOILER RELAY OPERATION. DPST RELAY MUST BE USED FOR HEAT RELAY.
 - FOR 500 SERIES UNIT OPERATION AT 208-3-60V LINE VOLTAGE, TRAN1 PRIMARY CONNECTIONS MUST BE MOVED TO TERMINALS H3 & H4.

FUSE NUMBER	UNIT VOLTAGE	TRANSFORMER SIZE	REPLACE WITH
FU1 & FU2	380-3-60, 460-3-60, 575-3-60	100VA	FNO-R-3/4
FU3 (24V)	208/230-3-60, 230-3-50, 380/415-3-50	100VA	FNO-R-2
FU4 (115V)	380-3-60, 460-3-60, 575-3-60	100VA	FNM-6
FU5 & FU6	208/230-3-60, 230-3-50, 380/415-3-50	500VA	FNM-6
	460-3-60, 575-3-60	500VA	FNO-R-2 1/2
	208/230-3-60, 230-3-60	500VA	FNO-R-3 1/2

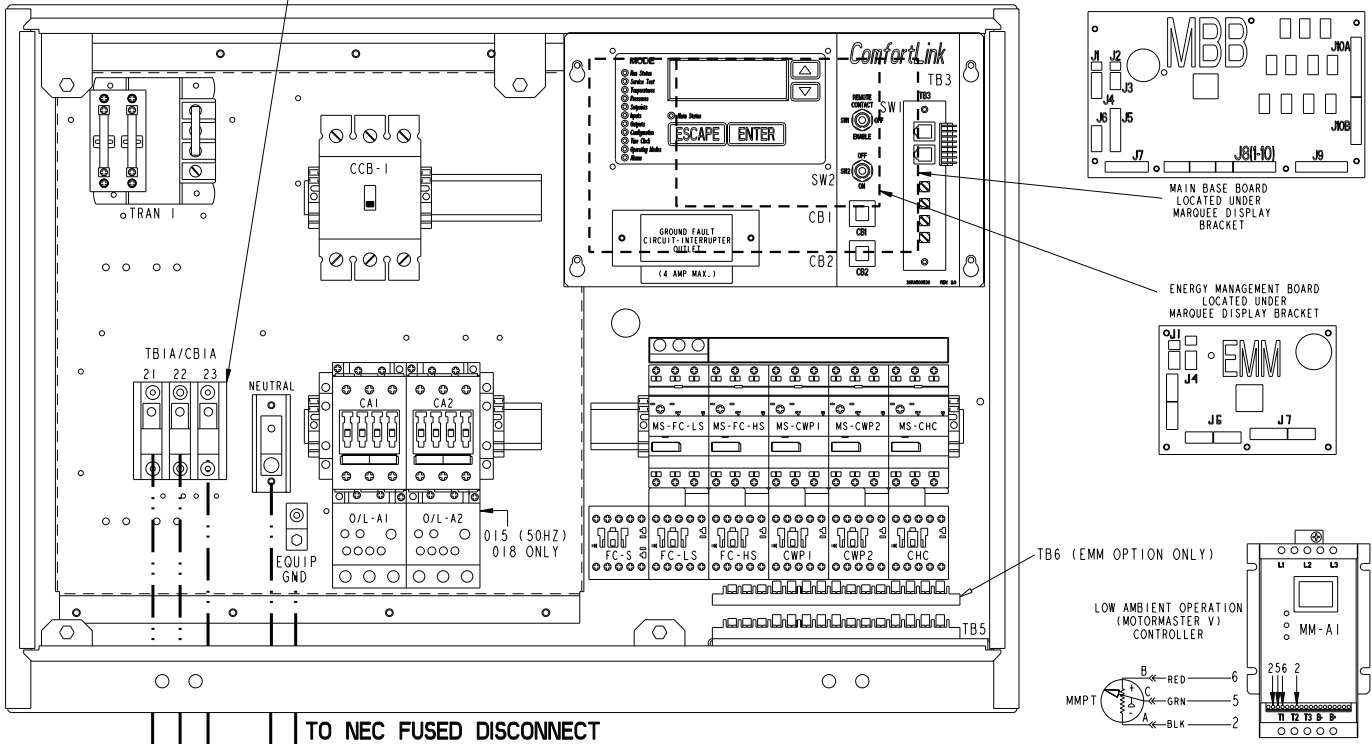
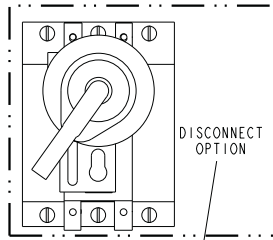
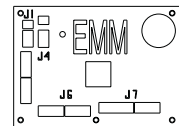
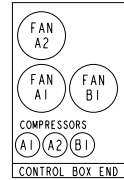


Fig. 22 — Component Arrangement — 30RA010-030

- LEGEND**
- C** — Contactor, Compressor
 - CB** — Circuit Breaker
 - CHC** — Cooler/Pump Heater Contactor
 - CWP** — Chilled Water Pump
 - EMM** — Energy Management
 - FC** — Fan Contactor
 - FIOP** — Factory-Installed Option
 - FU** — Fuse
 - GND** — Ground
 - MBB** — Main Base Board
 - MM** — Motormaster®
 - MMPT** — Motormaster Pressure Transducer
 - MS** — Manual Starter
 - NEC** — National Electrical Code
 - SW** — Switch
 - TB** — Terminal Block
 - TRAN** — Transformer
- Factory Wiring
 - - - - Field Wiring
 - - - - Accessory or Option Wiring

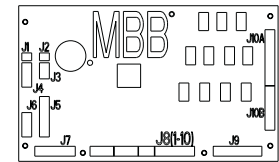
LOW AMBIENT OPERATION (MOTORMASTER V) FIOP/ACCESSORY		
UNIT VOLTAGE	CONFIGURATION JUMPER LOCATION	CONFIGURATION JUMPER COMMON LOCATION
575-3-60	1	2
380-3-60	13A	
230-3-60	1	
208-3-60	13A	
460-3-60	1	
230-3-50	13B	
380-3-50	13C	
415-3-50	13C	



ENERGY MANAGEMENT BOARD LOCATED UNDER SCROLLING MARQUEE BRACKET

- NOTES:**
- FACTORY WIRING IS IN ACCORDANCE WITH UL 1995 STANDARDS. ANY FIELD MODIFICATIONS OR ADDITIONS MUST BE IN COMPLIANCE WITH ALL APPLICABLE CODES.
 - USE 75°C MIN WIRE FOR FIELD POWER SUPPLY.
 - ALL COMPRESSOR MANUAL STARTERS "MUST TRIP AMPS" ARE EQUAL TO OR LESS THAN 156% FLA. ALL OTHER MANUAL STARTERS "MUST TRIP AMPS" ARE EQUAL TO OR LESS THAN 140% FLA.
 - ALL FIELD INTERLOCK CONTACTS MUST HAVE A MIN RATING OF 2 AMPS @ 24VAC SEALED. SEE FIELD INTERLOCK WIRING.
 - COMPRESSOR AND FAN MOTORS ARE THERMALLY PROTECTED--THREE PHASE MOTORS PROTECTED AGAINST PRIMARY SINGLE PHASE CONDITIONS.
 - INTERCHANGE FAN MOTOR CONNECTIONS 1 AND 3 TO ENSURE COUNTER CLOCKWISE FAN ROTATION.
 - TERMINALS 9 & 10 OF TB5 ARE FOR FIELD CONNECTION OF REMOTE ON-OFF. THE CONTACT MUST BE RATED FOR DRY CIRCUIT APPLICATION CAPABLE OF HANDLING A 5VDC 1 MA TO 20 MA LOAD.
 - ALARM RELAY MUST BE INSTALLED FOR HEATING/BOILER RELAY OPERATION. DPST RELAY MUST BE USED FOR HEAT RELAY.
 - FOR 500 SERIES UNIT OPERATION AT 208-3-60V LINE VOLTAGE, TRAN1 PRIMARY CONNECTIONS MUST BE MOVED TO TERMINALS H3 & H4.

FUSE NUMBER	UNIT VOLTAGE	TRANSFORMER SIZE	REPLACE WITH
FU1 & FU2	380-3-60, 460-3-60, 575-3-60	200VA	FNO-R-1 1/2
FU3	208/230-3-60, 230-3-50, 380/415-3-50	200VA	FNO-R-3
FU4 (24V)	380-3-60, 460-3-60, 575-3-60	200VA	FNM-10
FU4 (115V)	208/230-3-60, 230-3-50, 380/415-3-50	200VA	FNM-10
FU4	460-3-60, 575-3-60	500VA	FNM-6
FU5 & FU6	208/230-3-60, 230-3-60	500VA	FNO-R-2 1/2
FU5 & FU6	460-3-60, 575-3-60	500VA	FNO-R-2 1/2
FU5 & FU6	208/230-3-60, 230-3-60	500VA	FNO-R-3 1/2



MAIN BASE BOARD LOCATED UNDER SCROLLING MARQUEE BRACKET

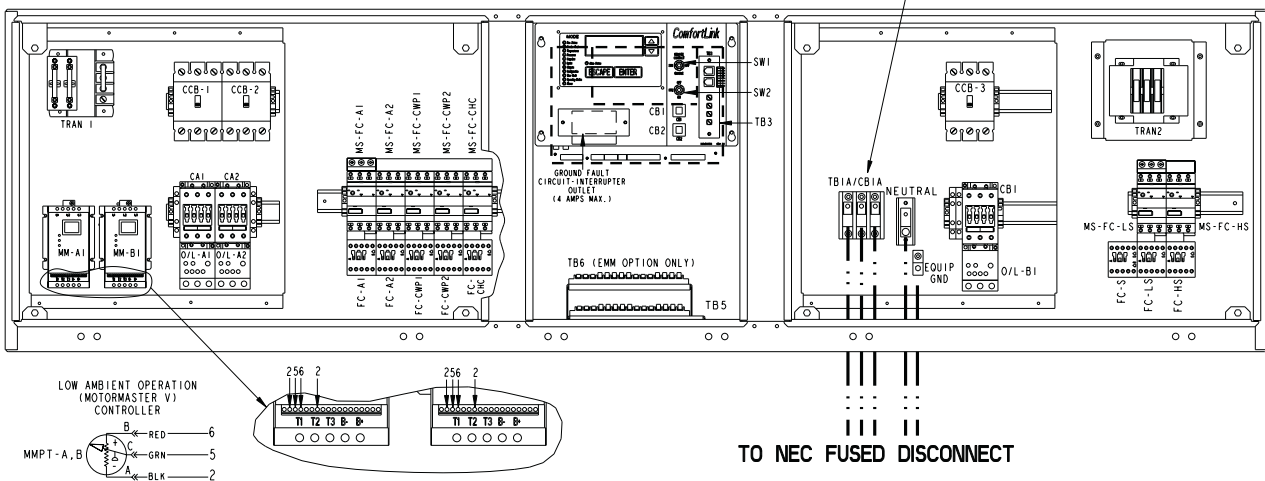
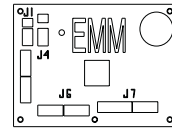
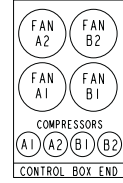


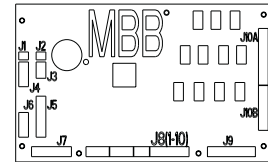
Fig. 23 — Component Arrangement — 30RA032-040

- LEGEND**
- C** — Contactor, Compressor
 - CB** — Circuit Breaker
 - CHC** — Cooler/Pump Heater Contactor
 - CWP** — Chilled Water Pump
 - EMM** — Energy Management
 - FC** — Fan Contactor
 - FIOP** — Factory-Installed Option
 - FU** — Fuse
 - GND** — Ground
 - MBB** — Main Base Board
 - MM** — Motormaster®
 - MMPT** — Motormaster Pressure Transducer
 - MS** — Manual Starter
 - NEC** — National Electrical Code
 - SW** — Switch
 - TB** — Terminal Block
 - TRAN** — Transformer
- Factory Wiring
 - - - - - Field Wiring
 - · - · - Accessory or Option Wiring

LOW AMBIENT OPERATION (MOTORMASTER V) FIOP/ACCESSORY		
UNIT VOLTAGE	CONFIGURATION JUMPER LOCATION	CONFIGURATION JUMPER COMMON LOCATION
575-3-60	1	2
380-3-60	13A	
230-3-60	1	
208-3-60	13A	
460-3-60	1	
230-3-50	13B	
380-3-50	13C	
415-3-50	13C	



ENERGY MANAGEMENT BOARD LOCATED UNDER SCROLLING MARQUEE BRACKET



MAIN BASE BOARD LOCATED UNDER SCROLLING MARQUEE BRACKET

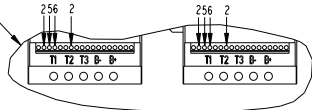
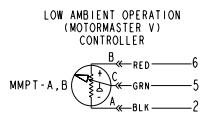
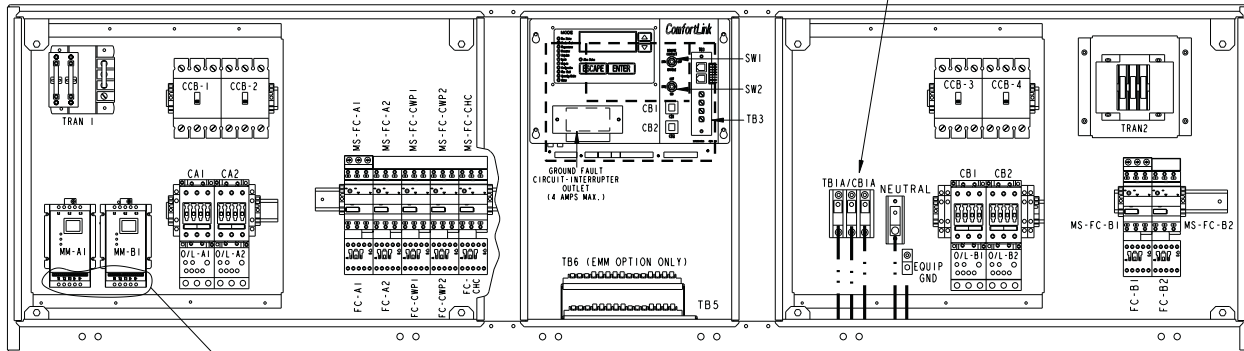
NOTES:

- FACTORY WIRING IS IN ACCORDANCE WITH UL 1995 STANDARDS. ANY FIELD MODIFICATIONS OR ADDITIONS MUST BE IN COMPLIANCE WITH ALL APPLICABLE CODES.
- USE 75°C MIN WIRE FOR FIELD POWER SUPPLY.
- ALL COMPRESSOR MANUAL STARTERS "MUST TRIP AMPS" ARE EQUAL TO OR LESS THAN 156% RLA. ALL OTHER MANUAL STARTERS "MUST TRIP AMPS" ARE EQUAL TO OR LESS THAN 140% FLA.
- ALL FIELD INTERLOCK CONTACTS MUST HAVE A MIN RATING OF 2 AMPS @ 24VAC SEALED. SEE FIELD INTERLOCK WIRING.
- COMPRESSOR AND FAN MOTORS ARE THERMALLY PROTECTED-- THREE PHASE MOTORS PROTECTED AGAINST PRIMARY SINGLE PHASE CONDITIONS.
- INTERCHANGE FAN MOTOR CONNECTIONS 1 AND 3 TO ENSURE COUNTER CLOCKWISE FAN ROTATION.
- TERMINALS 9 & 10 OF TB5 ARE FOR FIELD CONNECTION OF REMOTE ON-OFF. THE CONTACT MUST BE RATED FOR DRY CIRCUIT APPLICATION CAPABLE OF HANDLING A 5VDC 1 MA TO 20 MA LOAD.
- ALARM RELAY MUST BE INSTALLED FOR HEATING/BOILER RELAY OPERATION. DPST RELAY MUST BE USED FOR HEAT RELAY.
- FOR 500 SERIES UNIT OPERATION AT 208-3-60V LINE VOLTAGE, TRAN1 PRIMARY CONNECTIONS MUST BE MOVED TO TERMINALS H3 & H4.

FUSE NUMBER	UNIT VOLTAGE	TRANSFORMER SIZE	REPLACE WITH
FU1 & FU2	380-3-60, 460-3-60, 575-3-60	200VA	FNO-R-1 1/2
	208/230-3-60, 230-3-50, 380/415-3-50		FNO-R-3
FU3 (24V)	380-3-60, 460-3-60, 575-3-60	200VA	FNM-10
	208/230-3-60, 230-3-50, 380/415-3-50		
FU4 (115V)	460-3-60, 575-3-60	500VA	FNM-6
FU5 & FU6	208/230-3-60, 230-3-60	500VA	FNO-R-2 1/2
	460-3-60, 575-3-60		FNO-R-3 1/2



DISCONNECT OPTION

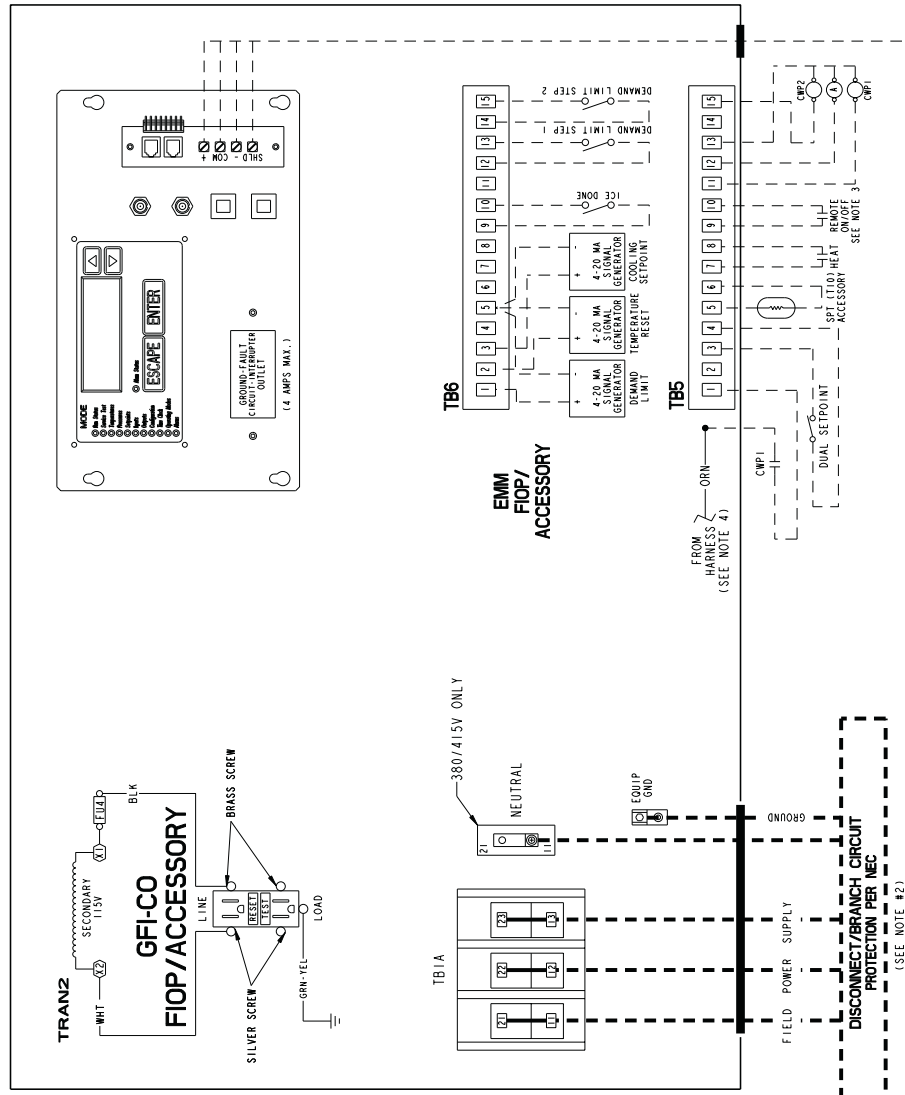


TO NEC FUSED DISCONNECT

Fig. 24 — Component Arrangement — 30RA042-055

- NOTES:**
- Factory wiring is in accordance with UL 1995 standards. Field modifications or additions must be in compliance with all applicable codes.
 - Wiring for main field supply must be rated 75 C minimum. Use copper for all units. Maximum incoming wire size for the terminal block is #20 AWG. Maximum incoming wire size for 60 and 100 amp non-fused disconnect is #1 AWG. Maximum incoming wire size for 250 amp non-fused disconnect is 350 kcmil.
 - Terminals 9 and 10 of TB5 are for field external connections for remote on-off. The contacts must be rated for dry circuit application capable of handling a 24 vac load up to 50 mA.
 - Terminals 1 and 2 of TB5 are connected to the factory-installed chilled water flow switch (CWFS). To add chilled water pump interlock contacts, remove the orange harness wire from TB5-1 and wire contacts in series as shown. The contacts must be rated for dry circuit application capable of handling a 24 vac load up to 50 mA.
 - Terminals 11 and 13 of TB5 are for control of chilled water pump 1 (CWPT1) starter. Terminals 13 and 15 of TB5 are for control of chilled water pump 2 (CWPT2) starter. The maximum load allowed for the chilled water pump relay is 5 va sealed, 10 va inrush at 24 v. Field power supply is not required.
 - Terminals 12 and 13 of TB5 are for an alarm relay. The maximum load allowed for the alarm relay is 5 va sealed, 10 va inrush at 24 v. Field power supply is not required.
 - Make appropriate connections to TB6 as shown for energy management board options. The contacts for demand limit and ice done options must be rated for dry circuit application capable of handling a 24 vac load up to 50 mA.
 - Care should be taken when interfacing with other manufacturer's control systems due to possible power supply differences: full wave bridge versus half wave rectification. The two different power supplies cannot be mixed. ComfortLink™ controls use half wave rectification. A signal isolation device should be utilized if a full wave bridge signal generating device is used.

- LEGEND**
- | | |
|--------------|------------------------------|
| A | Alarm |
| CWPT1 | Chilled Water Pump Interlock |
| CWP2 | Chilled Water Pump |
| EMM | Energy Management |
| FIOP | Factory-Installed Option |
| NEC | National Electrical Code |
| SPT | Space Temperature |
| TB | Terminal Block |
| --- | Field Power Wiring |
| - - - | Field Control Wiring |
| — | Factory-Installed Wiring |



NON-FUSED DISCONNECT POWER

STANDARD POWER

Fig. 25 — Control and Field Power Wiring Diagram — 30RA010-030

- NOTES:**
1. Factory wiring is in accordance with UL 1995 standards. Field modifications or additions must be in compliance with all applicable codes.
 2. Wiring for main field supply must be rated 75 C minimum. Use copper for all units. Maximum incoming wire size for the terminal block is 350 kcmil. Maximum incoming wire size for 100 amp non-fused disconnect is #1 AWG. Maximum incoming wire size for 250 amp non-fused disconnect is 350 kcmil.
 3. Terminals 9 and 10 of TB5 are for field external connections for remote on-off. The contacts must be rated for dry circuit application capable of handling a 24 vac load up to 50 mA.
 4. Terminals 1 and 2 of TB5 are connected to the factory-installed chilled water flow switch (CWFS). To add chilled water pump interlock contacts, remove the orange harness wire from TB5-1 and wire contacts in series as shown. The contacts must be rated for dry circuit application capable of handling a 24 vac load up to 50 mA.
 5. Terminals 11 and 13 of TB5 are for control of chilled water pump 1 (CWP1) starter. Terminals 13 and 15 of TB5 are for control of chilled water pump 2 (CWP2) starter. The maximum load allowed for the chilled water pump relay is 5 v sealed, 10 va inrush at 24 v. Field power supply is not required.
 6. Terminals 12 and 13 of TB5 are for an alarm relay. The maximum load allowed for the alarm relay is 75 va sealed, 360 va inrush at 115 v. Field power supply is not required.
 7. Make appropriate connections to TB6 as shown for energy management board options. The contacts for demand limit and ice done options must be rated for dry circuit application capable of handling a 24 vac load up to 50 mA.
 8. Care should be taken when interfacing with other manufacturer's control systems due to possible power supply differences: full wave bridge versus half wave rectification. The two different power supplies cannot be mixed. CombiLink™ controls use half wave rectification. A signal isolation device should be utilized if a full wave bridge signal generating device is used.

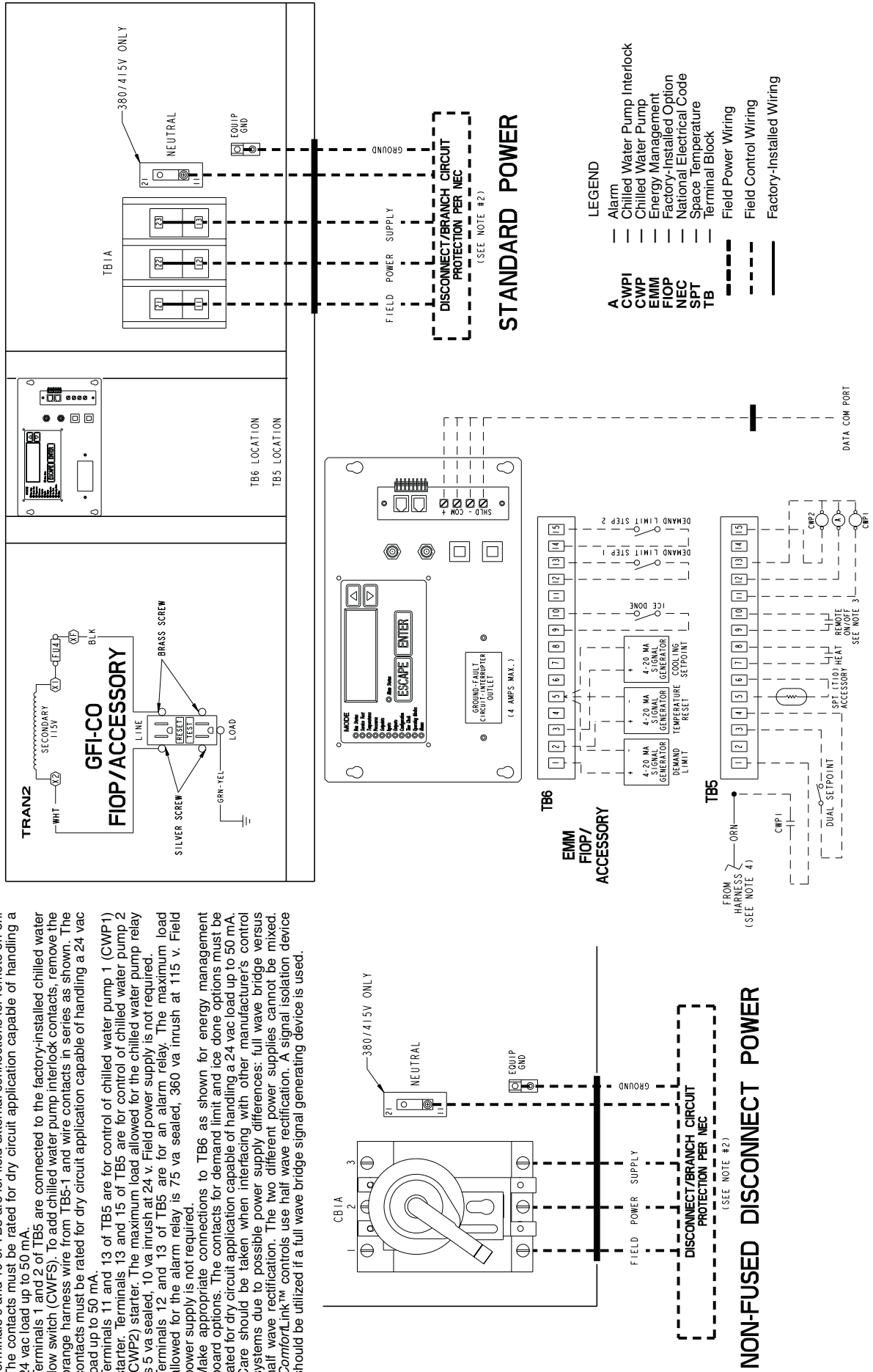


Fig. 26 — Control and Field Power Wiring Diagram — 30RA032-055

Alarms and Alerts — These are warnings of abnormal or fault conditions, and may cause either one circuit or the whole unit to shut down. They are assigned code numbers as described in Table 29.

Automatic alarms will reset without operator intervention if the condition corrects itself. The following method must be used to reset manual alarms:

Before resetting any alarm, first determine the cause of the alarm and correct it. Enter the Alarms mode indicated by the LED on the side of the Scrolling Marquee Display. Press **ENTER** and **▼** until the sub-menu item RCRN “RESET

ALL CURRENT ALARMS” is displayed. Press **ENTER**. The control will prompt the user for a password, by displaying PASS and WORD. Press **ENTER** to display the default password, 1111. Press **ENTER** for each character. If the password has been changed, use the arrow keys to change each individual character. Toggle the display to “YES” and press **ENTER**. The alarms will be reset.

Table 29 — Alarm and Alert Codes

ALARM/ALERT CODE	ALARM OR ALERT	DESCRIPTION	WHY WAS THIS ALARM GENERATED?	ACTION TAKEN BY CONTROL	RESET METHOD	PROBABLE CAUSE
T051	Alert	Circuit A, Compressor 1 Failure	Compressor feedback signal does not match relay state	Compressor A1 shut down.	Manual	High-pressure switch open, faulty auxiliary contacts, loss of condenser air, liquid valve closed, filter drier plugged, non-condensables, operation beyond capability.
T052	Alert	Circuit A, Compressor 2 Failure	Compressor feedback signal does not match relay state	Compressor A2 shut down.	Manual	High-pressure switch open, faulty auxiliary contacts, loss of condenser air, liquid valve closed, filter drier plugged, non-condensables, operation beyond capability.
T055	Alert	Circuit B, Compressor 1 Failure	Compressor feedback signal does not match relay state	Compressor B1 shut down.	Manual	High-pressure switch open, faulty auxiliary contacts, loss of condenser air, liquid valve closed, filter drier plugged, non-condensables, operation beyond capability.
T056	Alert	Circuit B, Compressor 2 Failure	Compressor feedback signal does not match relay state	Compressor B2 shut down.	Manual	High-pressure switch open, faulty auxiliary contacts, loss of condenser air, liquid valve closed, filter drier plugged, non-condensables, operation beyond capability.
A060	Alarm	Cooler Leaving Fluid Thermistor Failure (T1)	Thermistor outside range of -40 to 245 F (-40 to 118 C)	Chiller shutdown immediately	Automatic	Thermistor failure, damaged cable/wire or wiring error.
A061	Alarm	Cooler Entering Fluid Thermistor Failure (T2)	Thermistor outside range of -40 to 245 F (-40 to 118 C)	Chiller shutdown immediately	Automatic	Thermistor failure, damaged cable/wire or wiring error.
T068	None	Circuit A Return Gas Thermistor Failure	If return gas sensors are enabled (RG.EN) and thermistor is outside range of -40 to 245 F (-40 to 118 C)	None	Automatic	Thermistor failure, damaged cable/wire or wiring error.
T069	None	Circuit B Return Gas Thermistor Failure	If return gas sensors are enabled (RG.EN) and thermistor is outside range of -40 to 245 F (-40 to 118 C)	None	Automatic	Thermistor failure, damaged cable/wire or wiring error.
T073	Alert	Outside Air Thermistor Failure (T9)	Thermistor outside range of -40 to 245 F (-40 to 118 C)	Temperature reset disabled. Chiller runs under normal control/set points. When capacity reaches 0, cooler/pump heaters are energized.	Automatic	Thermistor failure, damaged cable/wire or wiring error.
T074	Alert	Space Temperature Thermistor Failure (T10)	Thermistor outside range of -40 to 245 F (-40 to 118 C)	Temperature reset disabled. Chiller runs under normal control/set points.	Automatic	Thermistor failure, damaged cable/wire or wiring error.
T077	Alert	Circuit A Saturated Suction Temperature exceeds Cooler Leaving Fluid Temperature	Faulty expansion valve, suction pressure transducer or leaving fluid thermistor (T1).	Circuit A shutdown after pumpdown complete.	Automatic	Faulty expansion valve or suction pressure transducer (T5) or leaving fluid thermistor (T1).
T078	Alert	Circuit B Saturated Suction Temperature exceeds Cooler Leaving Fluid Temperature	Faulty expansion valve, suction pressure transducer or leaving fluid thermistor (T1).	Circuit B shutdown after pumpdown complete	Automatic	Faulty expansion valve or suction pressure transducer (T6) or leaving fluid thermistor (T1).
T079	Alert	Lead/Lag LWT Thermistor Failure	Thermistor outside range of -40 to 245 F (-40 to 118 C)	Chiller runs as a stand alone machine	Automatic	Dual LWT thermistor failure, damaged cable/wire or wiring error.
T090	Alert	Circuit A Discharge Pressure Transducer Failure	Voltage ratio more than 99.9% or less than .5%.	Circuit A shut down	Automatic	Transducer failure, poor connection to MBB, or wiring damage/error.
T091	Alert	Circuit B Discharge Pressure Transducer Failure	Voltage ratio more than 99.9% or less than .5%.	Circuit B shut down	Automatic	Transducer failure, poor connection to MBB, or wiring damage/error.
T092	Alert	Circuit A Suction Pressure Transducer Failure	Voltage ratio more than 99.9% or less than .5%.	Circuit A shut down	Automatic	Transducer failure, poor connection to MBB, or wiring damage/error.

Table 29 — Alarm and Alert Codes (cont)

ALARM/ ALERT CODE	ALARM OR ALERT	DESCRIPTION	WHY WAS THIS ALARM GENERATED?	ACTION TAKEN BY CONTROL	RESET METHOD	PROBABLE CAUSE
T093	Alert	Circuit B Suction Pressure Transducer Failure	Voltage ratio more than 99.9% or less than .5%.	Circuit B shut down	Automatic	Transducer failure, poor connection to MBB, or wiring damage/error.
T110	Alert	Circuit A Loss of Charge	If the compressors are off and discharge pressure reading is < 10 psig for 30 sec.	Circuit not allowed to start.	Manual	Refrigerant leak or transducer failure
T111	Alert	Circuit B Loss of Charge	If the compressors are off and discharge pressure reading is < 10 psig for 30 sec.	Circuit not allowed to start.	Manual	Refrigerant leak or transducer failure
T112	Alert	Circuit A High Saturated Suction Temperature	Circuit saturated suction temperature pressure transducer > 60 F (15.6 C) for 5 minutes	Circuit shut down	Manual	Faulty Expansion valve, faulty suction pressure transducer or high entering fluid temperature.
T113	Alert	Circuit B High Saturated Suction Temperature	Circuit saturated suction temperature pressure transducer > 60 F (15.6 C) for 5 minutes	Circuit shut down	Manual	Faulty Expansion valve, faulty suction pressure transducer or high entering fluid temperature.
T114	Alert	Circuit A Low Suction Superheat	Return gas sensor enabled and suction superheat is more than 10° F (5.6 C) below the suction superheat set point for 5 minutes.	Circuit A shut down after pumpdown complete.	Automatic restart after first daily occurrence. Manual restart thereafter.	Faulty expansion valve, faulty suction pressure transducer, faulty suction gas thermistor, circuit overcharged
T115	Alert	Circuit B Low Suction Superheat	Return gas sensor enabled and suction superheat is more than 10° F (5.6 C) below the suction superheat set point for 5 minutes.	Circuit B shut down after pumpdown complete.	Automatic restart after first daily occurrence. Manual restart thereafter.	Faulty expansion valve, faulty suction pressure transducer, faulty suction gas thermistor, circuit overcharged
T116	Alert	Circuit A Low Cooler Suction Temperature	Mode 7 caused the compressor to unload 6 consecutive times with less than a 30-minute interval between each circuit shutdown.	Circuit shut down	Manual	Faulty expansion valve, low refrigerant charge, plugged filter drier, faulty suction pressure transducer, low cooler fluid flow
T117	Alert	Circuit B Low Cooler Suction Temperature	Mode 8 caused the compressor to unload 6 consecutive times with less than a 30-minute interval between each circuit shutdown.	Circuit shut down	Manual	Faulty expansion valve, low refrigerant charge, plugged filter drier, faulty suction pressure transducer, low cooler fluid flow
T126	Alert	Circuit A High Discharge Pressure	SCT >Maximum condensing temperature from operating envelope	Circuit shut down	Automatic, only after first 3 daily occurrences. Manual reset thereafter. Reading from OAT sensor (T9) must drop 5 F (2.8 C) before restart	Faulty transducer/high pressure switch, low/restricted condenser airflow
T127	Alert	Circuit B High Discharge Pressure	SCT >Maximum condensing temperature from operating envelope	Circuit shut down	Automatic, only after first 3 daily occurrences. Manual reset thereafter. Reading from OAT sensor (T9) must drop 5 F (2.8 C) before restart	Faulty transducer/high pressure switch, low/restricted condenser airflow
T133	Alert	Circuit A Low Suction Pressure	Suction pressure below 15 psig for 8 seconds or below 8 psig	Circuit shut down	Automatic restart after first daily occurrence. Manual restart thereafter.	Faulty or plugged TXV, low refrigerant charge, TXV out of adjustment, liquid line valve partially closed
T134	Alert	Circuit B Low Suction Pressure	Suction pressure below 15 psig for 8 seconds or below 8 psig	Circuit shut down	Automatic restart after first daily occurrence. Manual restart thereafter.	Faulty or plugged TXV, low refrigerant charge, TXV out of adjustment, liquid line valve partially closed

Table 29 — Alarm and Alert Codes (cont)

ALARM/ ALERT CODE	ALARM OR ALERT	DESCRIPTION	WHY WAS THIS ALARM GENERATED?	ACTION TAKEN BY CONTROL	RESET METHOD	PROBABLE CAUSE
A140	Alert	Reverse Rotation Detected	Incoming chiller power leads not phased correctly	Chiller not allowed to start.	Manual	Reverse any two incoming power leads to correct. Check for correct fan rotation first.
A150	Alarm	Emergency Stop	CCN emergency stop command received	Chiller shutdown without going through pumpdown.	Automatic once CCN command for EMSTOP returns to normal	CCN Network command.
A151	Alarm	Illegal Configuration	One or more illegal configurations exists.	Chiller is not allowed to start.	Manual once configuration errors are corrected	Configuration error. Check unit settings.
A152	Alarm	Unit Down Due to Failure	Both circuits are down due to alarms/alerts.	Chiller is unable to run.	Automatic once alarms/alerts are cleared that prevent the chiller from starting.	Alarm notifies user that chiller is 100% down.
T153	Alert	Real Time Clock Hardware Failure	Internal clock on MBB fails	Occupancy schedule will not be used. Chiller defaults to Local On mode.	Automatic when correct clock control restarts.	Time/Date/Month/Day/Year not properly set.
A154	Alarm	Serial EEPROM Hardware Failure	Hardware failure with MBB	Chiller is unable to run.	Manual	Main Base Board failure.
T155	Alert	Serial EEPROM Storage Failure	Configuration/storage failure with MBB	No Action	Manual	Potential failure of MBB. Download current operating software. Replace MBB if error occurs again.
A156	Alarm	Critical Serial EEPROM Storage Failure	Configuration/storage failure with MBB	Chiller is not allowed to run.	Manual	Main Base Board failure.
A157	Alarm	A/D Hardware Failure	Hardware failure with peripheral device	Chiller is not allowed to run.	Manual	Main Base Board failure.
A189	Alarm	Cooler pump auxiliary contact inputs miswired	Pump 1 (2) aux contacts closed when pump 2 (1) energized.	Both pump outputs are turned off.	Manual	Wiring error, faulty pump contactor auxiliary contacts.
T173	Alert	Loss of Communication with EMM	MBB loses communication with EMM	4 to 20 mA temperature reset disabled. Demand Limit set to 100%. 4 to 20 mA set point disabled.	Automatic	Wiring error, faulty wiring or failed Energy Management Module (EMM).
T174	Alert	4 to 20 mA Cooling Set Point Input Failure	If configured with EMM and input less than 2 mA or greater than 22 mA	Set point function disabled. Chiller controls to CSP1.	Automatic	Faulty signal generator, wiring error, or faulty EMM.
T176	Alert	4 to 20 mA Temperature Reset Input Failure	If configured with EMM and input less than 2 mA or greater than 22 mA	Reset function disabled. Chiller returns to normal set point control.	Automatic	Faulty signal generator, wiring error, or faulty EMM.
T177	Alert	4 to 20 mA Demand Limit Input Failure	If configured with EMM and input less than 2 mA or greater than 22 mA	Demand limit function disabled. Chiller returns to 100% demand limit control.	Automatic	Faulty signal generator, wiring error, or faulty EMM.
T189	Alarm	Cooler pump 2 and Aux Contact Input miswired	Alarm is generated when the pump's aux contacts close when a pump is called for	Chiller not allowed to start	Manual	Wiring error
T190	Alert	Cooler pump 1 Aux Contacts Failed to Close at Start-Up	Pump 1 Auxiliary Contacts did not close within 26 seconds after pump was started	Pump 1 turned off. Pump 2 will be started if available.	Manual	Wiring error, faulty contacts on pump contactor
T191	Alert	Cooler pump 2 Aux Contacts Failed to Close at Start-Up	Pump 2 Auxiliary Contacts did not close within 26 seconds after pump was started	Pump 2 turned off. Pump 1 will be started if available.	Manual	Wiring error, faulty contacts on pump contactor
T192	Alert	Cooler pump 1 Failed to Provide Flow at Start-Up	Pump 1 did not provide flow to close flow switch within 60 seconds	Pump 1 turned off. Pump 2 will be started if available.	Manual	Wiring error, pump circuit breaker tripped, contactor failure
T193	Alert	Cooler pump 2 Failed to Provide Flow at Start-Up	Pump 2 did not provide flow to close flow switch within 60 seconds	Pump 1 turned off. Pump 2 will be started if available.	Manual	Wiring error, pump circuit breaker tripped, contactor failure
T194	Alert	Cooler pump 1 Aux Contacts Opened During Normal Operation	Pump 1 Auxiliary Contacts open for 26 seconds after initially made. All compressors shut down. Pump 1 turned off.	Pump 2 will be started if available. Chiller allowed to run if Pump 2 successfully starts.	Manual	Wiring error, faulty contacts on pump contactor
T195	Alert	Cooler pump 2 Aux Contacts Opened During Normal Operation	Pump 2 Auxiliary Contacts open for 26 seconds after initially made. All compressors shut down. Pump 2 turned off.	Pump 1 will be started if available. Chiller allowed to run if Pump 1 successfully starts.	Manual	Wiring error, faulty contacts on pump contactor

Table 29 — Alarm and Alert Codes (cont)

ALARM/ ALERT CODE	ALARM OR ALERT	DESCRIPTION	WHY WAS THIS ALARM GENERATED?	ACTION TAKEN BY CONTROL	RESET METHOD	PROBABLE CAUSE
T196	Alert	Flow Lost While Pump 1 Running	Cooler flow switch contacts open for 3 seconds after initially made	All compressors shut down. Pump 1 turned off. Pump 2 will be started if available. Chiller allowed to run if Pump 2 successfully starts and flow switch is closed.	Manual	Wiring error, pump circuit breaker tripped, contactor failure
T197	Alert	Flow Lost While Pump 2 Running	Cooler flow switch contacts open for 3 seconds after initially made	All compressors shut down. Pump 2 turned off. Pump 1 will be started if available. Chiller allowed to run if Pump 1 successfully starts and flow switch is closed.	Manual	Wiring error, pump circuit breaker tripped, contactor failure
T198	Alert	Cooler pump 1 Aux Contacts Closed While Pump Off	Pump 1 Auxiliary Contacts closed for 26 seconds when pump state is off	Chiller not allowed to start	Automatic when aux contacts open	Wiring error, faulty pump contactor (welded contacts)
T199	Alert	Cooler pump 2 Aux Contacts Closed While Pump Off	Pump 2 Auxiliary Contacts closed for 26 seconds when pump state is off	Chiller not allowed to start	Automatic when aux contacts open	Wiring error, faulty pump contactor (welded contacts)
T200	Alert	Cooler Flow/Interlock Contacts failed to Close at start-up	Cooler flow switch contacts failed to close within 1 minute (if cooler pump control is enabled) or within 5 minutes (if cooler pump control is not enabled) after start-up	Chiller not allowed to start. For models with dual pumps, the second pump will be started if available	Manual	Wiring error, pump circuit breaker tripped, contactor failure, faulty flow switch or interlock
A201	Alarm	Cooler Flow/Interlock Contacts Opened During Normal Operation	Flow switch opens for at least 3 seconds after being initially closed	All compressors shut down. For models with dual pumps, the second pump will be started if available	Manual	Cooler pump failure, faulty flow switch or interlock, pump circuit breaker tripped
A202	Alarm	Cooler Pump Interlock Closed When Pump is Off	If configured for cooler pump control and flow switch input is closed for 5 minutes while pump output(s) are off	Chiller shut down	Automatic when aux contacts open	Wiring error, faulty pump contactor (welded contacts)
T203	Alert	Loss of Communication with slave chiller	Master chiller MBB loses communication with slave chiller MBB	Dual chiller control disabled. Chiller runs as a stand-alone machine.	Automatic	Wiring error, faulty wiring, failed Slave chiller MBB module, power loss at slave chiller, wrong slave address.
T204	Alert	Loss of Communication with master chiller	Slave chiller MBB loses communication with master chiller MBB	Dual chiller control disabled. Chiller runs as a stand-alone machine	Automatic	Wiring error, faulty wiring, failed master chiller MBB module, power loss at Master chiller.
T205	Alert	Master and slave chiller with same address	Master and slave chiller have the same CCN address (CCN.A)	Dual chiller routine disabled. Master/slave run as stand-alone chillers.	Automatic	CCN Address for both chillers is the same. Must be different. Check CCN.A under the OPT2 sub-mode in Configuration at both chillers.
T206	Alert	High Leaving Chilled Water Temperature	LWT read is greater than LCW Alert Limit, Total capacity is 100% and LWT is greater than LWT reading one minute ago	Alert only. No action taken.	Automatic	Building load greater than unit capacity, low water/brine flow or compressor fault. Check for other alarms/alerts.
A207	Alarm	Cooler Freeze Protection	Cooler EWT or LWT is less than Brine Freeze (BR.FZ)	Chiller shutdown without going through pumpdown. Cooler pump continues to run a minimum of 5 minutes (if control enabled).	Both EWT and LWT must be at least 6 F (3.3 C) above Brine Freeze point (BR.FZ). Automatic for first, Manual reset thereafter.	Faulty thermistor (T1/T2), low water flow.
A208	Alarm	EWT or LWT Thermistor failure	Cooler EWT is less than LWT by 3° F (1.7° C) for 1 minute after a circuit is started	Chiller shutdown. Cooler pump shut off (if control enabled).	Manual	Faulty cooler pump, low water flow, plugged fluid strainer.
T300	Alert	Cooler Pump 1 Scheduled Maintenance Due	Pump 1 Service Countdown (P.1.DN) expired. Complete pump 1 maintenance and enter 'YES' for Pump 1 Maintenance Done (P.1.MN) item.	None	Automatic	Routine pump maintenance required


Table 29 — Alarm and Alert Codes (cont)

ALARM/ ALERT CODE	ALARM OR ALERT	DESCRIPTION	WHY WAS THIS ALARM GENERATED?	ACTION TAKEN BY CONTROL	RESET METHOD	PROBABLE CAUSE
T301	Alert	Cooler Pump 2 Scheduled Maintenance Due	Pump 2 Service Countdown (P.2.DN) expired. Complete pump 2 maintenance and enter 'YES' for Pump 1 Maintenance Done (P.2.MN) item.	None	Automatic	Routine pump maintenance required
T302	Alert	Strainer Blowdown Scheduled Maintenance Due	Strainer Service Countdown (S.T.DN) expired. Complete strainer blowdown and enter 'YES' for Strainer Maintenance Done (S.T.MN) item.	None	Automatic	Routine strainer maintenance required
T303	Alert	Condenser Coil Maintenance Due	Coil Service Countdown (C.L.DN) expired. Complete condenser coil cleaning and enter 'YES' for Coil Maintenance Done (C.L.MN) item.	None	Automatic	Routine condenser coil maintenance required
T950	Alert	Loss of Communication with Water System Manager	No communications have been received by the MBB within 5 minutes of last transmission	WSM forces removed. Chiller runs under own control	Automatic	Failed module, wiring error, failed transformer, loose connection plug, wrong address
T951	Alert	Loss of Communication with Flotronic™ System Manager	No communications have been received by the MBB within 5 minutes of last transmission	FSM forces removed. Chiller runs under own control	Automatic	Failed module, wiring error, failed transformer, loose connection plug, wrong address
T952	Alert	Loss of Communication with Hydronic System Manager	No communications have been received by the MBB within 5 minutes of last transmission	HSM forces removed. Chiller runs under own control	Automatic	Failed module, wiring error, failed transformer, loose connection plug, wrong address

LEGEND

- CCN** — Carrier Comfort Network
- EMM** — Energy Management Module
- EWI** — Entering Fluid Temperature
- FSM** — Flotronic™ System Manager
- HSM** — Hydronic System Manager
- LCW** — Leaving Chilled Water
- LWT** — Leaving Fluid Temperature
- MBB** — Main Base Board
- OAT** — Outdoor-Air Temperature
- SCT** — Saturated Condensing Temperature
- TXV** — Thermostatic Expansion Valve
- WSM** — Water System Manager

SERVICE

	<p>ELECTRIC SHOCK HAZARD.</p> <p>Turn off all power to unit before servicing. The ENABLE/OFF/REMOTE CONTACT switch on control panel does <i>not</i> shut off control power; <i>use field disconnect.</i></p>
---	---

Electronic Components

CONTROL COMPONENTS — Unit uses an advanced electronic control system that normally does not require service. For details on controls refer to Operating Data section.

Access to the compressors is through latched panels from beneath the control box on all models or from opposite the coil side (sizes 010-030 only). The front door(s) provide access to the compressor(s) and all components of the refrigeration system. For size 010-030 units, access to the controls is through the upper latched outer door above the compressor access door. Similarly, the upper center latched door on sizes 032-055 gives access to the controls. Inner panels are secured in place and should not be removed unless all power to the chiller is off.

Compressor Replacement (Refer to Fig. 27-30) — All models contain scroll compressors and have from one to four compressors. The size 010-030 units are a single refrigeration circuit while sizes 032-055 are dual circuit. A compressor is most easily removed from the front of the unit, depending on where clearance space was allowed during unit installation.

Unscrew the junction box cover bolts and disconnect the compressor power and ground connections. Remove the cable from the compressor junction box. Remove the connections from the internal thermostat and high-pressure switch (all compressors except SM110) or high-pressure switch connections (SM110 only). Knock the same holes out of the new compressor junction box and install the cable connectors from the old compressor. Remove the blockoff channel from below the control box.

Be sure the oil equalization line fitting is removed from the old compressor and installed on the new compressor for those models with dual compressor circuits. The compressors are bolted to the unit basepan. Remove the 4 bolts holding the compressor to the basepan. Save the mounting hardware for use with the new compressor. Carefully cut the compressor suction and discharge lines with a tubing cutter as close to the compressor as feasible. For dual compressor circuits, do NOT disturb the suction line tee at the backside of the compressors. This tee contains a special tube that is required for proper oil return. Remove high-pressure switch and pressure transducer(s) if required for compressor removal. Lift one corner of the compressor at a time and remove all the rubber mounting grommets. Remove the old compressor from the unit.

Slide the new compressor in place on the basepan. Lifting one side of the compressor at a time, replace all of the compressor mounting grommets. Using new tubing or couplings as required, reconnect compressor suction and discharge lines. Using hardware saved, reinstall the mounting bolts and washers through the compressor feet. Using proper techniques, braze suction and discharge lines and check for leaks. Reconnect oil equalization line on dual compressor circuit models.

Reconnect the compressor power connections and high-pressure switch/internal thermostat wiring as on the old compressor. Refer to Fig. 27-30. Following the installation of the new compressor, tighten all hardware to the following specifications. (See Table 30.)

Table 30 — Unit Torque Specification

FASTENER	RECOMMENDED TORQUE
Compressor Mounting Bolts	10 to 14 ft-lb (13.5 to 18.9 N-m)
Compressor Power Connections	24 to 28 in.-lb (2.7- to 3.2 N-m)
Compressor Ground Terminal Connections	14 to 18 in.-lb (1.6 to 2.0 N-m)
Oil Equalization Line Fitting	10 to 13 ft-lb (13.5 to 17.6 N-m)

Cooler

BRAZED-PLATE COOLER HEAT EXCHANGER REPLACEMENT — Brazed-plate heat exchangers cannot be repaired if they develop a leak. If a leak (refrigerant or water) develops, the heat exchanger **must be** replaced. To replace a brazed plate heat exchanger:

1. Disconnect the liquid-in and liquid-out connections at the heat exchanger.
2. Check that the replacement heat exchanger is the same as the original heat exchanger. The unit insulation covers the manufacturer's part number. Make sure the depths of the replacement and original cooler heat exchangers are the same.
3. Reclaim the refrigerant from the system, and unsolder the refrigerant-in and refrigerant-out connections.
4. Remove the old heat exchanger and the bracket that it is mounted to. The replacement heat exchanger is supplied attached to a new mounting bracket and is fully insulated. It also includes a cooler heater. Use of the heater is not required unless the original cooler contained a factory installed heater.
5. Install the replacement heat exchanger in the unit and attach the mounting bracket hardware to the fan uprights (sizes 010-030) or to the bottom bracket (sizes 032-055) using the hardware removed in Step 4. Reconnect the cooler heater if required.
6. *Carefully* braze the refrigerant lines to the connections on the heat exchanger. Lines should be soldered using silver as the soldering material with a minimum of 45% silver. Keep the temperature below 1472 F (800 C) under normal soldering conditions (no vacuum) to prevent the copper solder of the brazed plate heat exchanger from changing its structure. Failure to do so can result in internal or external leakage at the connections which cannot be repaired.
7. Reconnect the water/brine lines.
8. Dehydrate and recharge the unit. Check for leaks.

BRAZED-PLATE COOLER HEAT EXCHANGER CLEANING — Brazed-plate heat exchangers must be cleaned chemically. A professional cleaning service skilled in chemical cleaning should be used. Use a weak acid (5% phosphoric acid, or if the heat exchanger is cleaned frequently, 5% oxalic acid). Pump the cleaning solution through the exchanger, preferably in a backflush mode. After cleaning, rinse with large amounts of fresh water to dispose of all the acid. Cleaning materials must be disposed of properly.

The factory-installed strainer screen in front of the water/brine inlets of the heat exchangers should be cleaned periodically, depending on condition of the chiller water/brine.

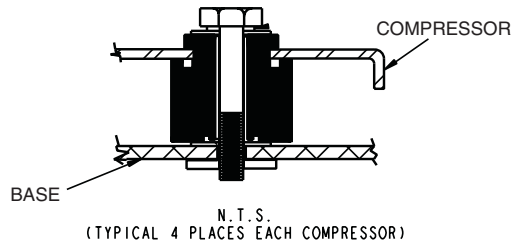


Fig. 27 — Typical Compressor Mounting — All Sizes

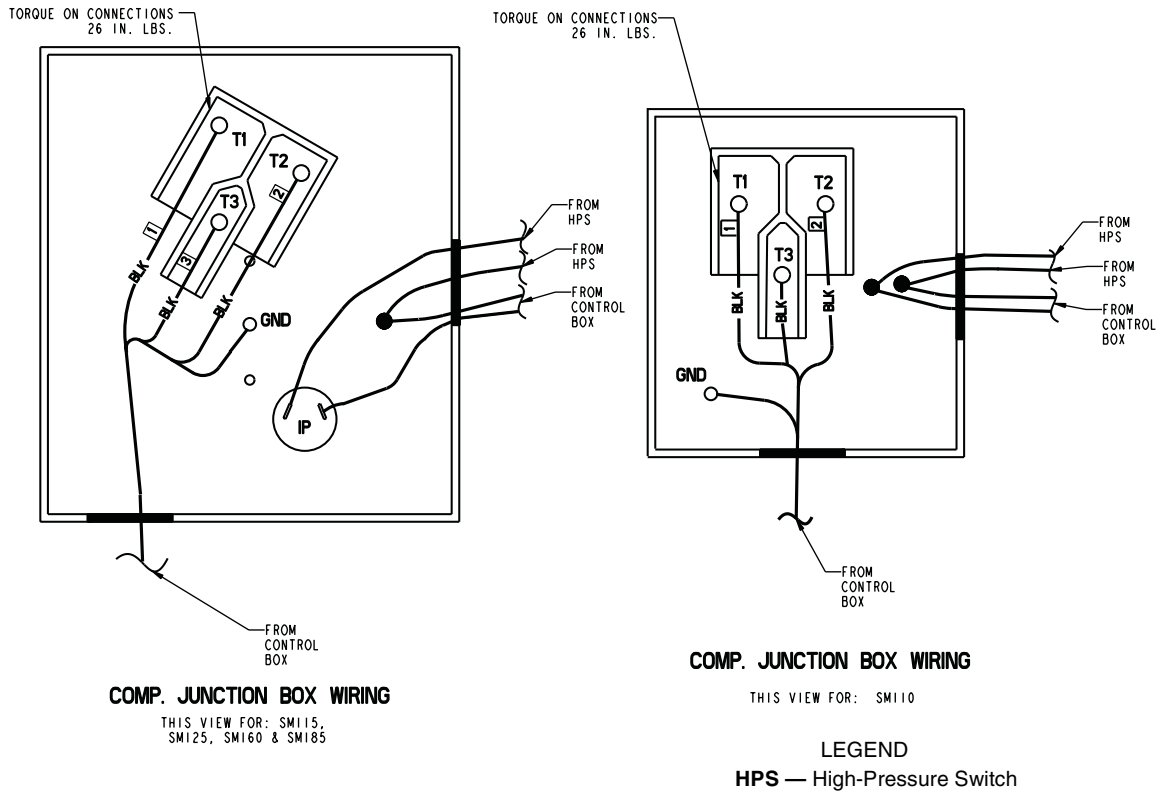


Fig. 28 — Compressor Wiring

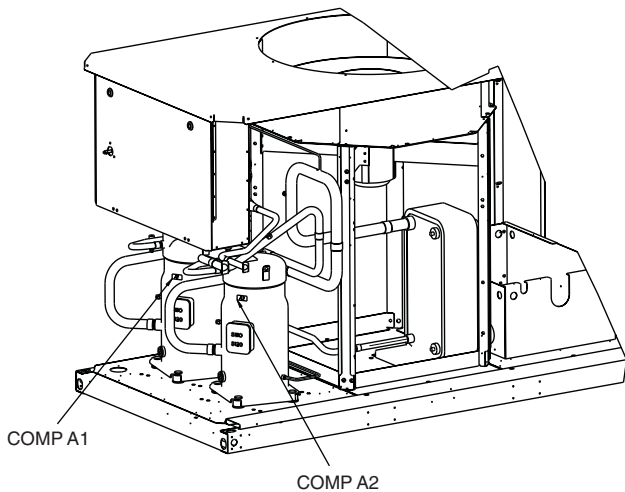


Fig. 29 — Compressor Location — 30RA010-030

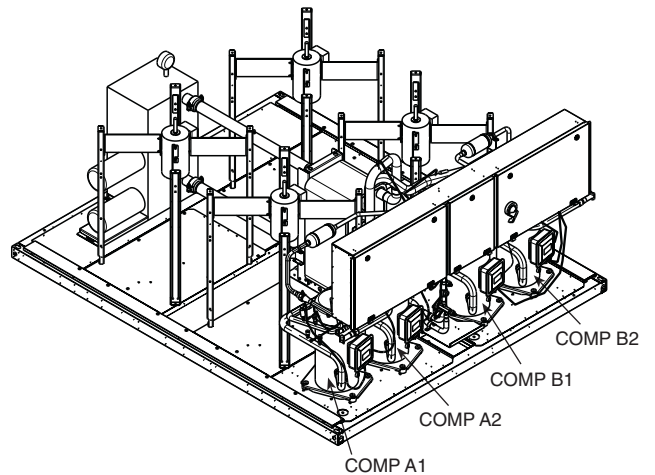


Fig. 30 — Compressor Location — 30RA032-055

Check Oil Charge — Compressors are factory charged with oil as shown in Table 31.

Table 31 — Oil Charge

COMPRESSOR	AMOUNT pints (liters)
SM110	5.7 (2.7)
SM115, SM125	6.7 (3.2)
SM160	7.0 (3.3)
SM185	11.6 (5.5)

If oil is visible in the compressor sight glass, check unit for operating readiness as described in Pre-Start-Up, System Check section (page 74), then start the unit. Observe oil level and add oil if required, to bring oil level in compressor crankcase up to between 1/4 and 3/4 of sight glass during steady operation.

To Add Oil:

1. Check the oil level with all compressors in the circuit running in a stabilized condition or immediately after compressor shutdown. The oil level should be at 1/3 of the oil sight glass immediately after shutdown.
2. Using a suitable pump, add oil while compressor(s) are running through the low side 1/4 in. Schraeder fitting on the compressor. For SM110 models, this fitting is directly above the suction line connection. For all other compressor models, this fitting is near the oil equalization line fitting at the same height as the suction line connection.
3. Run all compressors on the circuit for at least 15 minutes and check the oil level.

Use only Carrier-approved compressor oil:

Totaline PP680002
 Penreco Sontex 160 LT-A

Do not reuse drained oil, and do not use any oil that has been exposed to the atmosphere.

Condenser Section and Coils

COIL CLEANING — For standard aluminum, copper and pre-coated aluminum fin coils, clean the coils with a vacuum cleaner, fresh water, compressed air, or a bristle brush (not wire). Units installed in corrosive environments should have coil cleaning as part of a planned maintenance schedule. In this type of application, all accumulations of dirt should be cleaned off the coil. When condenser cleaning is complete, enter “Yes” for coil cleaning maintenance done (CL.MN) value under Run Status.

⚠ CAUTION

Do not use high-pressure water or air to clean coils — fin damage may result.

CLEANING E-COATED COILS — Follow the outlined procedure below for proper care, cleaning and maintenance of E-coated aluminum or copper fin coils:

Coil Maintenance and Cleaning Recommendations — Routine cleaning of coil surfaces is essential to maintain proper operation of the unit. Elimination of contamination and removal of harmful residues will greatly increase the life of the coil and extend the life of the unit.

Remove Surface Loaded Fibers — Surface loaded fibers or dirt should be removed with a vacuum cleaner. If a vacuum cleaner is not available, a soft brush may be used. In either case, the tool should be applied in the direction of the fins. Coil

surfaces can be easily damaged (fin edges bent over) if the tool is applied across the fins.

NOTE: Use of a water stream, such as a garden hose, against a surface loaded coil will drive the fibers and dirt into the coil. This will make cleaning efforts more difficult. Surface loaded fibers must be completely removed prior to using low velocity clean water rinse.

Periodic Clean Water Rinse — A periodic clean water rinse is very beneficial for coils that are applied in coastal or industrial environments. However, it is very important that the water rinse is made with very low velocity water stream to avoid damaging the fin edges. Monthly cleaning as described below is recommended.

Routine Cleaning of Coil Surfaces — Monthly cleaning with Environmentally Sound Coil Cleaner is essential to extend the life of coils. It is recommended that all coils, including standard aluminum, pre-coated, copper/copper or E-coated coils are cleaned with the Environmentally Sound Coil Cleaner as described below. Coil cleaning should be part of the units regularly scheduled maintenance procedures to ensure long life of the coil. Failure to clean the coils may result in reduced durability in the environment.

Environmentally Sound Coil Cleaner is non-flammable, hypo allergenic, non-bacterial, USDA accepted biodegradable and 100% ecologically safe agent that will not harm the coil or surrounding components such as electrical wiring, painted metal surfaces or insulation. Use of non-recommended coil cleaners is strongly discouraged since coil and unit durability could be affected.

Environmentally Sound Coil Cleaner Application Equipment

- 2 1/2 Gallon Garden Sprayer
- Water Rinse with Low Velocity Spray Nozzle

Environmentally Sound Coil Cleaner Application Instructions

- Although Environmentally Sound Coil Cleaner is harmless to humans, animals, and marine life, proper eye protection such as safety glasses is recommended during mixing and application.
- Remove all surface loaded fibers and dirt with a vacuum cleaner as described above.
- Thoroughly wet finned surfaces with clean water and a low velocity garden hose being careful not to bend fins.
- Mix Environmentally Sound Coil Cleaner in a 2 1/2 gallon garden sprayer according to the instructions included with the Enzyme Cleaner. The optimum solution temperature is 100 F.

NOTE: DO NOT USE water in excess of 130 F as the enzymatic activity will be destroyed.

- Thoroughly apply Environmentally Sound Coil Cleaner solution to all coil surfaces including finned area, tube sheets and coil headers.
- Hold garden sprayer nozzle close to finned areas and apply cleaner with a vertical, up-and-down motion. Avoid spraying in horizontal pattern to minimize potential for fin damage.
- Ensure cleaner thoroughly penetrates deep into finned areas.
- Interior and exterior finned areas must be thoroughly cleaned.
- Finned surfaces should remain wet with cleaning solution for 10 minutes.
- Ensure surfaces are not allowed to dry before rinsing. Reapply cleaner as needed to ensure 10-minute saturation is achieved.

- Thoroughly rinse all surfaces with low velocity clean water using downward rinsing motion of water spray nozzle. Protect fins from damage from the spray nozzle.

⚠ CAUTION

Harsh Chemical and Acid Cleaners — Harsh chemical, household bleach or acid cleaners should not be used to clean outdoor or indoors coils of any kind. These cleaners can be very difficult to rinse out of the coil and can accelerate corrosion at the fin/tube interface where dissimilar materials are in contact. If there is dirt below the surface of the coil, use the Environmentally Sound Coil Cleaner as described above.

High Velocity Water or Compressed Air — High velocity water from a pressure washer, garden hose or compressed air should never be used to clean a coil. The force of the water or air jet will bend the fin edges and increase airside pressure drop. Reduced unit performance or nuisance unit shutdown may occur.

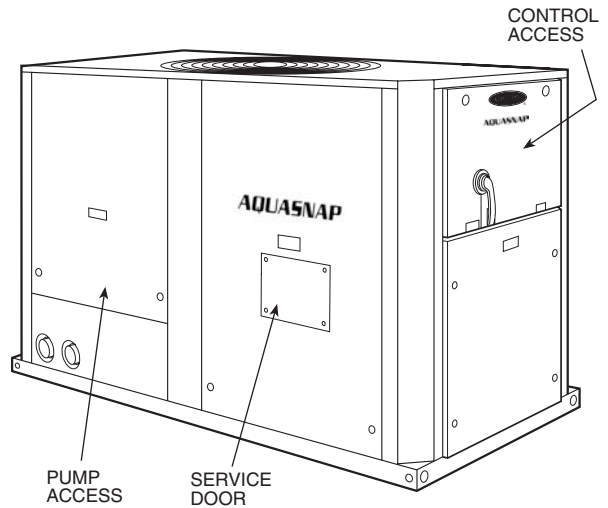


Fig. 31 — 30RA Access Panels

CONDENSER SECTION — Condenser fan motors and fans can be serviced by removal of outlet grilles or side panels. See Fig. 31. Be sure the wire fan guard is in place over each fan before starting unit. See Fig. 32 and 33 for proper fan adjustment. Fan mounting system is designed for fan to drop all the way on the motor shaft to be correctly located in the orifice. Tighten fan hub securely on motor shaft with setscrews which bear against the key. Be sure to replace the plastic fan cap and secure in place with the four locking clips to keep water and debris out of shaft area.

Check Refrigerant Feed Components

THERMOSTATIC EXPANSION VALVE (TXV) — The TXV controls the flow of liquid refrigerant to the cooler by maintaining constant superheat of vapor leaving the cooler. There is one valve per refrigerant circuit. The valve(s) is activated by a temperature-sensing bulb(s) strapped to the suction line(s). For proper TXV sensing bulb location, see Fig. 34.

The valve is factory-set to maintain between 8 and 12 F (4.4 and 6.7 C) of superheat entering the compressor(s). Elevate head pressure to 280 psig (1930 kPa) by blocking the airflow through the condenser. Check the superheat during operation after conditions have stabilized. A factory-installed temperature well is in each suction line for this purpose. If necessary, adjust the superheat to prevent refrigerant floodback to the compressor. Adjust TXVs 1/2 turn at a time, allowing the circuit to stabilize between adjustments. Turn stem counter-clockwise to decrease superheat and clockwise to increase superheat.

FILTER DRIER — The function of the filter drier is to maintain a clean, dry system. The moisture indicator (described below) indicates any need to change the filter drier. The filter drier is a sealed-type drier. When the drier needs to be changed, the entire filter drier must be replaced.

NOTE: Dual circuit (032-055 sizes) units have 1 filter drier per circuit.

MOISTURE-LIQUID INDICATOR — The indicator is located immediately ahead of the TXV to provide an indication of the refrigerant moisture content. It also provides a sight glass for refrigerant liquid. Clear flow of liquid refrigerant (*at full unit loading*) indicates sufficient charge in the system. Bubbles in the sight glass (*at full unit loading*) indicate an undercharged system or the presence of noncondensables. Moisture in the system, measured in parts per million (ppm), changes the color of the indicator as follows:

- Green (safe) — Moisture is below 45 ppm
- Yellow-Green (caution) — 45 to 130 ppm
- Yellow (wet) — above 130 ppm

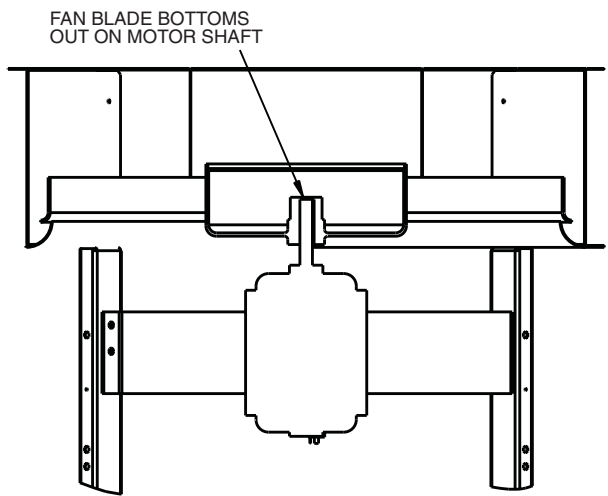


Fig. 32 — Condenser-Fan Mounting

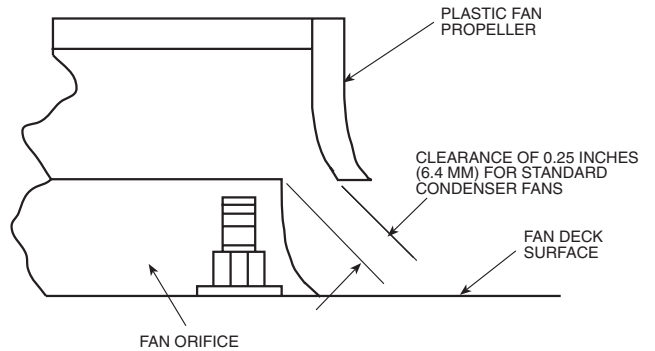


Fig. 33 — Condenser-Fan Position (Standard Fan)

The unit must be in operation at least 12 hours before the moisture indicator gives an accurate reading, and must be in contact with *liquid* refrigerant. At the first sign of moisture in the system, change the corresponding filter drier.

NOTE: Dual circuit (032-055 sizes) units have one indicator per circuit.

MINIMUM LOAD VALVE — On units equipped with the factory-installed capacity reduction option, a solenoid valve (minimum load valve) is located between the discharge line and the cooler entering-refrigerant line. The MBB cycles the solenoid to perform minimum load valve function.

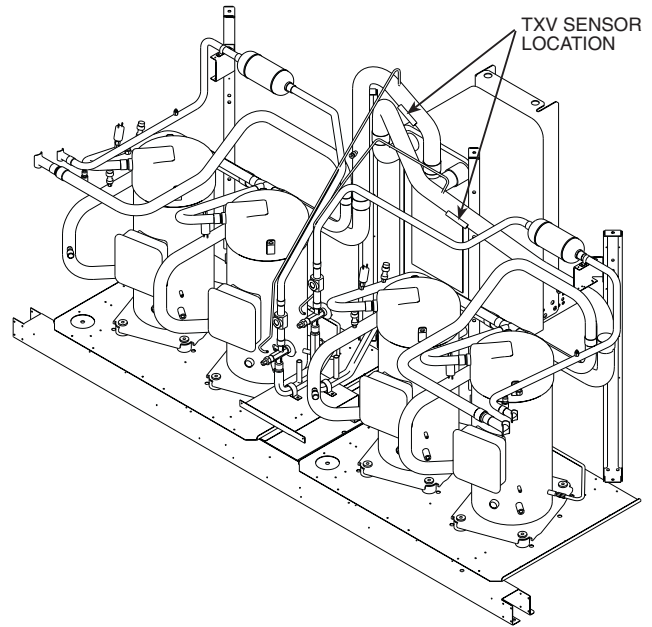
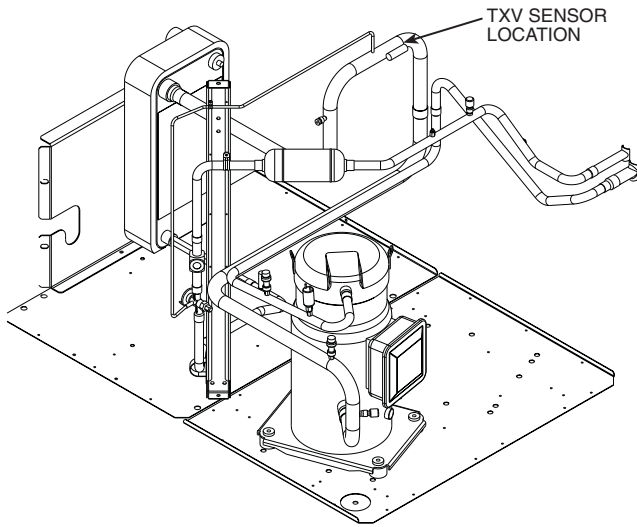


Fig. 34 — Mounting Locations for TXV Sensing Bulb

The amount of capacity reduction achieved by the minimum load valve is not adjustable. The total unit capacity with the minimum load valve is shown in Table 7.

PRESSURE RELIEF DEVICES — All units have one pressure relief device per circuit located in the liquid line which relieves at 210 F (100 C).

Compressor and Unit Protective Devices

MANUAL STARTER — There is one manual starter per compressor in each unit. It protects the compressor(s) against overloading, locked rotor conditions, and primary single phasing. If the manual starter trips, determine the cause and correct it before resetting.

Manual starters are factory set; field adjustment should not be required. Manual starters are also factory installed for each condenser fan motor and factory-installed chilled water pump.

NOTE: Two-speed condenser fan motors on sizes 010-018 and 032-040 have manual starters so that the motor is protected while running in both low and high speed modes. Refer to Appendix B for factory settings.

COMPRESSOR INTERNAL THERMAL PROTECTION — All models include internal compressor protection. Models using the SM110 compressor (015 50 Hz and 018 60 Hz) have internal line break overloads. All other compressor models have internal discharge temperature thermostats that are wired in series with the compressor high pressure switch in the compressor motor junction box. The thermostat opens and shuts off the compressor if the discharge gas temperature exceeds 275 F (135 C). The thermostat will automatically reset when the temperature drops below a preset level, however, the control module will keep the unit locked off until the alert condition is reset.

Check Unit Safeties

HIGH-PRESSURE SWITCH — A high-pressure switch is provided to protect each compressor and refrigeration system from unsafe high pressure conditions. See Table 32 for high-pressure switch settings.

The high-pressure switch is mounted in the discharge side of each compressor. A snubber is provided between the compressor discharge manifold and the high-pressure switch to prevent pressure pulsations from damaging the switch.

The high-pressure switch is mounted in the discharge line of each compressor. If an unsafe, high-pressure condition should exist, the switch opens and shuts off the affected compressor. The compressor feedback signal to J9 of the MBB then opens causing an alert condition. The MBB prevents the compressor from restarting until the alert condition is reset. The switch should open at the pressure corresponding to the appropriate switch setting as shown in Table 32.

Table 32 — Factory Settings, High-Pressure Switch (Fixed)

UNIT	CUTOUT		CUT-IN	
	Psig	kPa	Psig	kPa
30RA	426 ± 7	2937 ± 48	324 ± 20	2206 ± 138

Clear the alarm using the Scrolling Marquee display as described on page 42. The unit should restart after the compressor anti-short-cycle delay, built into the unit control module, expires.

PRESSURE TRANSDUCERS — Each refrigerant circuit is equipped with a suction and discharge pressure transducer. The transducers are NOT the same part number. The discharge pressure transducer is the universal pressure transducer while the suction pressure transducer is a discrete low pressure transducer. These inputs to the MBB are not only used to monitor the status of the unit, but to also maintain operation of the chiller within the compressor manufacturer's specified limits. The input to the MBB from the suction pressure transducer is also used to protect the compressor from operating at low pressure conditions. In some cases, the unit may not be able to run at full capacity. The control module will automatically reduce the capacity of a circuit as needed to maintain specified maximum/minimum operating pressures.

COOLER FREEZE-UP PROTECTION

▲ WARNING

On medium temperature brine units, the brine must be properly mixed to prevent freezing at a temperature of at least 15 F (8.3 C) below the leaving-fluid temperature set point. Failure to provide the proper brine mixture is considered abuse and may void the Carrier warranty.

The Main Base Board (MBB) monitors leaving fluid temperature at all times. The MBB will rapidly remove stages of capacity as necessary to prevent freezing conditions due to the rapid loss of load or low cooler fluid flow.

When the cooler is exposed to lower ambient temperatures (34 F [1° C] or below), freeze-up protection is required using inhibited ethylene glycol.

HEATER CABLE — Optional factory-installed cooler and/or hydronic package heaters are cycled based on the input from the outside-air temperature sensor. These heaters, when installed, are designed to protect the cooler and/or hydronic package from freezing down to -20 F (-29 C). Power for these heaters is supplied from the main unit power.

The input from the low pressure transducer provides a back-up cooler freeze protection package. The MBB shuts down the unit when a low pressure condition exists that could cause the cooler to freeze up.

▲ CAUTION

Do not disconnect main unit power when servicing compressor(s) if ambient temperature is below 40 F (4.4 C). Each compressor manual starter has a lockout feature. Depress the Stop Button and pull the lockout tab from the start button. Secure lock in place. If power to the unit must be off for a prolonged period, drain the cooler, hydronic package (if installed) and internal piping. Add glycol according to WINTER SHUTDOWN Step 2 below.

WINTER SHUTDOWN — At the end of the cooling season:

1. Drain the water/brine from the cooler, hydronic package (if installed) and internal piping.
2. Fill the package with at least 2 gallons (7.6 L) of ethylene glycol or other suitable uninhibited antifreeze solution to prevent any residual water in the cooler and hydronic package/piping from freezing.
3. At the beginning of the next cooling season, refill the cooler and add the recommended inhibitor.

Thermistors — Electronic control uses up to five 5 kΩ thermistors to sense temperatures used to control operation of the chiller. Thermistors T1, T2 and T9 are identical in their temperature and voltage drop performance. Accessory return gas thermistors are also 5 kΩ thermistors used to troubleshoot TXV superheat settings. Thermistor T10 has a 10 kΩ input channel and has a different set of temperature vs. resistance and voltage drop performance. Resistance at various temperatures are listed in Tables 33-36.

NOTE: For dual chiller operation, the control automatically configures the T10 input channel to be a 5 kΩ channel. A HH79NZ014 or HH79NZ029 thermistor should be used for dual chiller configurations.

Thermistor pin connection points are shown in Table 2. Thermistor T1 is located in a well at the bottom of the brazed plate heat exchanger for sizes 010-030 and in the leaving fluid piping for sizes 032-055.

Thermistor T2 is located in a well at the top of the brazed plate heat exchanger for sizes 010-030 and in the entering fluid piping for sizes 032-055. Thermistor T9 is factory installed in

the compressor section behind a panel with a vent plug so that outside air flows across the sensor tip.

REPLACING THERMISTORS T1 and T2 — Add a small amount of thermal conductive grease to the thermistor well and end of probe. Thermistors are friction-fit thermistors, which must be slipped into receivers in the cooler (010-030) or fluid piping (032-055). For sizes 032-055, tighten the retaining nut ¼ turn past finger tight. See Fig. 35.

THERMISTOR/TEMPERATURE SENSOR CHECK — A high quality digital volt-ohmmeter is required to perform this check.

1. Connect the digital voltmeter across the appropriate thermistor terminals at the J8 terminal strip on the Main Base Board (see Fig. 36).
2. Using the voltage reading obtained, read the sensor temperature from Tables 33-36.
3. To check thermistor accuracy, measure temperature at probe location with an accurate thermocouple-type temperature measuring instrument. Insulate thermocouple to avoid ambient temperatures from influencing reading. Temperature measured by thermocouple and temperature determined from thermistor voltage reading should be close, ± 5° F (3° C) if care was taken in applying thermocouple and taking readings.

If a more accurate check is required, unit must be shut down and thermistor removed and checked at a known temperature (freezing point or boiling point of water) using either voltage drop measured across thermistor at the J8 terminal, by determining the resistance with chiller shut down and thermistor disconnected from J8. Compare the values determined with the value read by the control in the Temperatures mode using the Scrolling Marquee display.

Pressure Transducers — Suction and discharge pressure transducers are installed on each circuit. No pressure transducer calibration is required. The transducers operate on a 5 vdc supply, which is generated by the Main Base Board (MBB). See Fig. 36 for transducer connections to the J8 connector on the MBB.

TROUBLESHOOTING — If a transducer is suspected of being faulty, first check the supply voltage to transducer. Supply voltage should be 5 vdc ± 0.2 v. If supply voltage is correct, compare pressure reading displayed on the Scrolling Marquee display module against pressure shown on a calibrated pressure gauge. Suction pressure should be within ± 2 psig. Discharge pressure should be within ± 5 psig. If the two readings are not reasonably close, replace the pressure transducer.

Flow Sensor — A flow switch is factory installed in the leaving fluid piping of all models. If the unit is equipped with an optional hydronic system, the flow switch is inside the pump cabinet. If nuisance trips of the sensor are occurring, follow the steps below to correct the situation:

1. Check to confirm that the factory installed strainer is clean. Use the blow-down valve provided or remove the screen and clean it. For the case of VFD controlled pumps, ensure that the minimum speed setting has not been changed.
2. Measure the pressure drop across the cooler or cooler/pump system and compare this to the system requirements.
3. Verify that cable connections at the switch and at the terminal block are secure.
4. For factory-installed hydronic systems, verify that:
 - All air has been purged from the system
 - Circuit setter balance valve has been correctly set
5. Pump impeller has been improperly trimmed and is not providing sufficient flow.
6. Wrong pump motor rotation. Pump must rotate clockwise when viewed from motor end of pump.

**Table 33 — 5K Thermistor Temperatures (°F) vs. Resistance/Voltage Drop
(Voltage Drop for Entering, Leaving Water and Outside-Air Thermistors T1, T2, T9)**

TEMP (F)	VOLTAGE DROP (V)	RESISTANCE (Ohms)	TEMP (F)	VOLTAGE DROP (V)	RESISTANCE (Ohms)	TEMP (F)	VOLTAGE DROP (V)	RESISTANCE (Ohms)
-25	3.699	98,010	59	1.982	7,686	143	0.511	1,190
-24	3.689	94,707	60	1.956	7,665	144	0.502	1,165
-23	3.679	91,522	61	1.930	7,468	145	0.494	1,141
-22	3.668	88,449	62	1.905	7,277	146	0.485	1,118
-21	3.658	85,486	63	1.879	7,091	147	0.477	1,095
-20	3.647	82,627	64	1.854	6,911	148	0.469	1,072
-19	3.636	79,871	65	1.829	6,735	149	0.461	1,050
-18	3.624	77,212	66	1.804	6,564	150	0.453	1,029
-17	3.613	74,648	67	1.779	6,399	151	0.445	1,007
-16	3.601	72,175	68	1.754	6,238	152	0.438	986
-15	3.588	69,790	69	1.729	6,081	153	0.430	965
-14	3.576	67,490	70	1.705	5,929	154	0.423	945
-13	3.563	65,272	71	1.681	5,781	155	0.416	925
-12	3.550	63,133	72	1.656	5,637	156	0.408	906
-11	3.536	61,070	73	1.632	5,497	157	0.402	887
-10	3.523	59,081	74	1.609	5,361	158	0.395	868
-9	3.509	57,162	75	1.585	5,229	159	0.388	850
-8	3.494	55,311	76	1.562	5,101	160	0.381	832
-7	3.480	53,526	77	1.538	4,976	161	0.375	815
-6	3.465	51,804	78	1.516	4,855	162	0.369	798
-5	3.450	50,143	79	1.493	4,737	163	0.362	782
-4	3.434	48,541	80	1.470	4,622	164	0.356	765
-3	3.418	46,996	81	1.448	4,511	165	0.350	750
-2	3.402	45,505	82	1.426	4,403	166	0.344	734
-1	3.386	44,066	83	1.404	4,298	167	0.339	719
0	3.369	42,679	84	1.382	4,196	168	0.333	705
1	3.352	41,339	85	1.361	4,096	169	0.327	690
2	3.335	40,047	86	1.340	4,000	170	0.322	677
3	3.317	38,800	87	1.319	3,906	171	0.317	663
4	3.299	37,596	88	1.298	3,814	172	0.311	650
5	3.281	36,435	89	1.278	3,726	173	0.306	638
6	3.262	35,313	90	1.257	3,640	174	0.301	626
7	3.243	34,231	91	1.237	3,556	175	0.296	614
8	3.224	33,185	92	1.217	3,474	176	0.291	602
9	3.205	32,176	93	1.198	3,395	177	0.286	591
10	3.185	31,202	94	1.179	3,318	178	0.282	581
11	3.165	30,260	95	1.160	3,243	179	0.277	570
12	3.145	29,351	96	1.141	3,170	180	0.272	561
13	3.124	28,473	97	1.122	3,099	181	0.268	551
14	3.103	27,624	98	1.104	3,031	182	0.264	542
15	3.082	26,804	99	1.086	2,964	183	0.259	533
16	3.060	26,011	100	1.068	2,898	184	0.255	524
17	3.038	25,245	101	1.051	2,835	185	0.251	516
18	3.016	24,505	102	1.033	2,773	186	0.247	508
19	2.994	23,789	103	1.016	2,713	187	0.243	501
20	2.972	23,096	104	0.999	2,655	188	0.239	494
21	2.949	22,427	105	0.983	2,597	189	0.235	487
22	2.926	21,779	106	0.966	2,542	190	0.231	480
23	2.903	21,153	107	0.950	2,488	191	0.228	473
24	2.879	20,547	108	0.934	2,436	192	0.224	467
25	2.856	19,960	109	0.918	2,385	193	0.220	461
26	2.832	19,393	110	0.903	2,335	194	0.217	456
27	2.808	18,843	111	0.888	2,286	195	0.213	450
28	2.784	18,311	112	0.873	2,239	196	0.210	445
29	2.759	17,796	113	0.858	2,192	197	0.206	439
30	2.735	17,297	114	0.843	2,147	198	0.203	434
31	2.710	16,814	115	0.829	2,103	199	0.200	429
32	2.685	16,346	116	0.815	2,060	200	0.197	424
33	2.660	15,892	117	0.801	2,018	201	0.194	419
34	2.634	15,453	118	0.787	1,977	202	0.191	415
35	2.609	15,027	119	0.774	1,937	203	0.188	410
36	2.583	14,614	120	0.761	1,898	204	0.185	405
37	2.558	14,214	121	0.748	1,860	205	0.182	401
38	2.532	13,826	122	0.735	1,822	206	0.179	396
39	2.506	13,449	123	0.723	1,786	207	0.176	391
40	2.480	13,084	124	0.710	1,750	208	0.173	386
41	2.454	12,730	125	0.698	1,715	209	0.171	382
42	2.428	12,387	126	0.686	1,680	210	0.168	377
43	2.402	12,053	127	0.674	1,647	211	0.165	372
44	2.376	11,730	128	0.663	1,614	212	0.163	367
45	2.349	11,416	129	0.651	1,582	213	0.160	361
46	2.323	11,112	130	0.640	1,550	214	0.158	356
47	2.296	10,816	131	0.629	1,519	215	0.155	350
48	2.270	10,529	132	0.618	1,489	216	0.153	344
49	2.244	10,250	133	0.608	1,459	217	0.151	338
50	2.217	9,979	134	0.597	1,430	218	0.148	332
51	2.191	9,717	135	0.587	1,401	219	0.146	325
52	2.165	9,461	136	0.577	1,373	220	0.144	318
53	2.138	9,213	137	0.567	1,345	221	0.142	311
54	2.112	8,973	138	0.557	1,318	222	0.140	304
55	2.086	8,739	139	0.548	1,291	223	0.138	297
56	2.060	8,511	140	0.538	1,265	224	0.135	289
57	2.034	8,291	141	0.529	1,240	225	0.133	282
58	2.008	8,076	142	0.520	1,214			

**Table 34 — 5K Thermistor Temperatures (°C) vs. Resistance/Voltage Drop
(Voltage Drop for Entering, Leaving Water and Outside-Air Thermistors T1, T2, T9)**

TEMP (C)	VOLTAGE DROP (V)	RESISTANCE (Ohms)	TEMP (C)	VOLTAGE DROP (V)	RESISTANCE (Ohms)	TEMP (C)	VOLTAGE DROP (V)	RESISTANCE (Ohms)
-32	3.705	100,260	15	1.982	7,855	62	0.506	1,158
-31	3.687	94,165	16	1.935	7,499	63	0.490	1,118
-30	3.668	88,480	17	1.889	7,161	64	0.475	1,079
-29	3.649	83,170	18	1.844	6,840	65	0.461	1,041
-28	3.629	78,125	19	1.799	6,536	66	0.447	1,006
-27	3.608	73,580	20	1.754	6,246	67	0.433	971
-26	3.586	69,250	21	1.710	5,971	68	0.420	938
-25	3.563	65,205	22	1.666	5,710	69	0.407	906
-24	3.539	61,420	23	1.623	5,461	70	0.395	876
-23	3.514	57,875	24	1.580	5,225	71	0.383	836
-22	3.489	54,555	25	1.538	5,000	72	0.371	805
-21	3.462	51,450	26	1.497	4,786	73	0.360	775
-20	3.434	48,536	27	1.457	4,583	74	0.349	747
-19	3.406	45,807	28	1.417	4,389	75	0.339	719
-18	3.376	43,247	29	1.378	4,204	76	0.329	693
-17	3.345	40,845	30	1.340	4,028	77	0.319	669
-16	3.313	38,592	31	1.302	3,861	78	0.309	645
-15	3.281	38,476	32	1.265	3,701	79	0.300	623
-14	3.247	34,489	33	1.229	3,549	80	0.291	602
-13	3.212	32,621	34	1.194	3,404	81	0.283	583
-12	3.177	30,866	35	1.160	3,266	82	0.274	564
-11	3.140	29,216	36	1.126	3,134	83	0.266	547
-10	3.103	27,633	37	1.093	3,008	84	0.258	531
-9	3.065	26,202	38	1.061	2,888	85	0.251	516
-8	3.025	24,827	39	1.030	2,773	86	0.244	502
-7	2.985	23,532	40	0.999	2,663	87	0.237	489
-6	2.945	22,313	41	0.969	2,559	88	0.230	477
-5	2.903	21,163	42	0.940	2,459	89	0.223	466
-4	2.860	20,079	43	0.912	2,363	90	0.217	456
-3	2.817	19,058	44	0.885	2,272	91	0.211	446
-2	2.774	18,094	45	0.858	2,184	92	0.204	436
-1	2.730	17,184	46	0.832	2,101	93	0.199	427
0	2.685	16,325	47	0.807	2,021	94	0.193	419
1	2.639	15,515	48	0.782	1,944	95	0.188	410
2	2.593	14,749	49	0.758	1,871	96	0.182	402
3	2.547	14,026	50	0.735	1,801	97	0.177	393
4	2.500	13,342	51	0.713	1,734	98	0.172	385
5	2.454	12,696	52	0.691	1,670	99	0.168	376
6	2.407	12,085	53	0.669	1,609	100	0.163	367
7	2.360	11,506	54	0.649	1,550	101	0.158	357
8	2.312	10,959	55	0.629	1,493	102	0.154	346
9	2.265	10,441	56	0.610	1,439	103	0.150	335
10	2.217	9,949	57	0.591	1,387	104	0.146	324
11	2.170	9,485	58	0.573	1,337	105	0.142	312
12	2.123	9,044	59	0.555	1,290	106	0.138	299
13	2.076	8,627	60	0.538	1,244	107	0.134	285
14	2.029	8,231	61	0.522	1,200			

**Table 35 — 10K Thermistor Temperature (°F) vs. Resistance/Voltage Drop
(For Thermistor T10)**

TEMP (F)	VOLTAGE DROP (V)	RESISTANCE (Ohms)	TEMP (F)	VOLTAGE DROP (V)	RESISTANCE (Ohms)	TEMP (F)	VOLTAGE DROP (V)	RESISTANCE (Ohms)
-25	4.758	196,453	61	2.994	14,925	147	0.890	2,166
-24	4.750	189,692	62	2.963	14,549	148	0.876	2,124
-23	4.741	183,300	63	2.932	14,180	149	0.862	2,083
-22	4.733	177,000	64	2.901	13,824	150	0.848	2,043
-21	4.724	171,079	65	2.870	13,478	151	0.835	2,003
-20	4.715	165,238	66	2.839	13,139	152	0.821	1,966
-19	4.705	159,717	67	2.808	12,814	153	0.808	1,928
-18	4.696	154,344	68	2.777	12,493	154	0.795	1,891
-17	4.686	149,194	69	2.746	12,187	155	0.782	1,855
-16	4.676	144,250	70	2.715	11,884	156	0.770	1,820
-15	4.665	139,443	71	2.684	11,593	157	0.758	1,786
-14	4.655	134,891	72	2.653	11,308	158	0.745	1,752
-13	4.644	130,402	73	2.622	11,031	159	0.733	1,719
-12	4.633	126,183	74	2.592	10,764	160	0.722	1,687
-11	4.621	122,018	75	2.561	10,501	161	0.710	1,656
-10	4.609	118,076	76	2.530	10,249	162	0.699	1,625
-9	4.597	114,236	77	2.500	10,000	163	0.687	1,594
-8	4.585	110,549	78	2.470	9,762	164	0.676	1,565
-7	4.572	107,006	79	2.439	9,526	165	0.666	1,536
-6	4.560	103,558	80	2.409	9,300	166	0.655	1,508
-5	4.546	100,287	81	2.379	9,078	167	0.645	1,480
-4	4.533	97,060	82	2.349	8,862	168	0.634	1,453
-3	4.519	94,020	83	2.319	8,653	169	0.624	1,426
-2	4.505	91,019	84	2.290	8,448	170	0.614	1,400
-1	4.490	88,171	85	2.260	8,251	171	0.604	1,375
0	4.476	85,396	86	2.231	8,056	172	0.595	1,350
1	4.461	82,729	87	2.202	7,869	173	0.585	1,326
2	4.445	80,162	88	2.173	7,685	174	0.576	1,302
3	4.429	77,662	89	2.144	7,507	175	0.567	1,278
4	4.413	75,286	90	2.115	7,333	176	0.558	1,255
5	4.397	72,940	91	2.087	7,165	177	0.549	1,233
6	4.380	70,727	92	2.059	6,999	178	0.540	1,211
7	4.363	68,542	93	2.030	6,838	179	0.532	1,190
8	4.346	66,465	94	2.003	6,683	180	0.523	1,169
9	4.328	64,439	95	1.975	6,530	181	0.515	1,148
10	4.310	62,491	96	1.948	6,383	182	0.507	1,128
11	4.292	60,612	97	1.921	6,238	183	0.499	1,108
12	4.273	58,781	98	1.894	6,098	184	0.491	1,089
13	4.254	57,039	99	1.867	5,961	185	0.483	1,070
14	4.235	55,319	100	1.841	5,827	186	0.476	1,052
15	4.215	53,693	101	1.815	5,698	187	0.468	1,033
16	4.195	52,086	102	1.789	5,571	188	0.461	1,016
17	4.174	50,557	103	1.763	5,449	189	0.454	998
18	4.153	49,065	104	1.738	5,327	190	0.447	981
19	4.132	47,627	105	1.713	5,210	191	0.440	964
20	4.111	46,240	106	1.688	5,095	192	0.433	947
21	4.089	44,888	107	1.663	4,984	193	0.426	931
22	4.067	43,598	108	1.639	4,876	194	0.419	915
23	4.044	42,324	109	1.615	4,769	195	0.413	900
24	4.021	41,118	110	1.591	4,666	196	0.407	885
25	3.998	39,926	111	1.567	4,564	197	0.400	870
26	3.975	38,790	112	1.544	4,467	198	0.394	855
27	3.951	37,681	113	1.521	4,370	199	0.388	841
28	3.927	36,610	114	1.498	4,277	200	0.382	827
29	3.903	35,577	115	1.475	4,185	201	0.376	814
30	3.878	34,569	116	1.453	4,096	202	0.370	800
31	3.853	33,606	117	1.431	4,008	203	0.365	787
32	3.828	32,654	118	1.409	3,923	204	0.359	774
33	3.802	31,752	119	1.387	3,840	205	0.354	762
34	3.776	30,860	120	1.366	3,759	206	0.349	749
35	3.750	30,009	121	1.345	3,681	207	0.343	737
36	3.723	29,177	122	1.324	3,603	208	0.338	725
37	3.697	28,373	123	1.304	3,529	209	0.333	714
38	3.670	27,597	124	1.284	3,455	210	0.328	702
39	3.654	26,838	125	1.264	3,383	211	0.323	691
40	3.615	26,113	126	1.244	3,313	212	0.318	680
41	3.587	25,396	127	1.225	3,244	213	0.314	670
42	3.559	24,715	128	1.206	3,178	214	0.309	659
43	3.531	24,042	129	1.187	3,112	215	0.305	649
44	3.503	23,399	130	1.168	3,049	216	0.300	639
45	3.474	22,770	131	1.150	2,986	217	0.296	629
46	3.445	22,161	132	1.132	2,926	218	0.292	620
47	3.416	21,573	133	1.114	2,866	219	0.288	610
48	3.387	20,998	134	1.096	2,809	220	0.284	601
49	3.357	20,447	135	1.079	2,752	221	0.279	592
50	3.328	19,903	136	1.062	2,697	222	0.275	583
51	3.298	19,386	137	1.045	2,643	223	0.272	574
52	3.268	18,874	138	1.028	2,590	224	0.268	566
53	3.238	18,384	139	1.012	2,539	225	0.264	557
54	3.208	17,904	140	0.996	2,488			
55	3.178	17,441	141	0.980	2,439			
56	3.147	16,991	142	0.965	2,391			
57	3.117	16,552	143	0.949	2,343			
58	3.086	16,131	144	0.934	2,297			
59	3.056	15,714	145	0.919	2,253			
60	3.025	15,317	146	0.905	2,209			

**Table 36 — 10K Thermistor Temperature (°C) vs. Resistance/Voltage Drop
(For Thermistor T10)**

TEMP (C)	VOLTAGE DROP (V)	RESISTANCE (Ohms)	TEMP (C)	VOLTAGE DROP (V)	RESISTANCE (Ohms)	TEMP (C)	VOLTAGE DROP (V)	RESISTANCE (Ohms)
-32	4.762	200,510	15	3.056	15,714	62	0.940	2,315
-31	4.748	188,340	16	3.000	15,000	63	0.913	2,235
-30	4.733	177,000	17	2.944	14,323	64	0.887	2,157
-29	4.716	166,342	18	2.889	13,681	65	0.862	2,083
-28	4.700	156,404	19	2.833	13,071	66	0.837	2,011
-27	4.682	147,134	20	2.777	12,493	67	0.813	1,943
-26	4.663	138,482	21	2.721	11,942	68	0.790	1,876
-25	4.644	130,402	22	2.666	11,418	69	0.767	1,813
-24	4.624	122,807	23	2.610	10,921	70	0.745	1,752
-23	4.602	115,710	24	2.555	10,449	71	0.724	1,693
-22	4.580	109,075	25	2.500	10,000	72	0.703	1,637
-21	4.557	102,868	26	2.445	9,571	73	0.683	1,582
-20	4.533	97,060	27	2.391	9,164	74	0.663	1,530
-19	4.508	91,588	28	2.337	8,776	75	0.645	1,480
-18	4.482	86,463	29	2.284	8,407	76	0.626	1,431
-17	4.455	81,662	30	2.231	8,056	77	0.608	1,385
-16	4.426	77,162	31	2.178	7,720	78	0.591	1,340
-15	4.397	72,940	32	2.127	7,401	79	0.574	1,297
-14	4.367	68,957	33	2.075	7,096	80	0.558	1,255
-13	4.335	65,219	34	2.025	6,806	81	0.542	1,215
-12	4.303	61,711	35	1.975	6,530	82	0.527	1,177
-11	4.269	58,415	36	1.926	6,266	83	0.512	1,140
-10	4.235	55,319	37	1.878	6,014	84	0.497	1,104
-9	4.199	52,392	38	1.830	5,774	85	0.483	1,070
-8	4.162	49,640	39	1.784	5,546	86	0.470	1,037
-7	4.124	47,052	40	1.738	5,327	87	0.457	1,005
-6	4.085	44,617	41	1.692	5,117	88	0.444	974
-5	4.044	42,324	42	1.648	4,918	89	0.431	944
-4	4.003	40,153	43	1.605	4,727	90	0.419	915
-3	3.961	38,109	44	1.562	4,544	91	0.408	889
-2	3.917	36,182	45	1.521	4,370	92	0.396	861
-1	3.873	34,367	46	1.480	4,203	93	0.386	836
0	3.828	32,654	47	1.439	4,042	94	0.375	811
1	3.781	31,030	48	1.400	3,889	95	0.365	787
2	3.734	29,498	49	1.362	3,743	96	0.355	764
3	3.686	28,052	50	1.324	3,603	97	0.345	742
4	3.637	26,686	51	1.288	3,469	98	0.336	721
5	3.587	25,396	52	1.252	3,340	99	0.327	700
6	3.537	24,171	53	1.217	3,217	100	0.318	680
7	3.485	23,013	54	1.183	3,099	101	0.310	661
8	3.433	21,918	55	1.150	2,986	102	0.302	643
9	3.381	20,883	56	1.117	2,878	103	0.294	626
10	3.328	19,903	57	1.086	2,774	104	0.287	609
11	3.274	18,972	58	1.055	2,675	105	0.279	592
12	3.220	18,090	59	1.025	2,579	106	0.272	576
13	3.165	17,255	60	0.996	2,488	107	0.265	561
14	3.111	16,464	61	0.968	2,400			

Strainer — Periodic factory-installed strainer cleaning is required. Pressure drop across strainer in excess of 3 psi (21 kPa) indicates the need for cleaning. Normal (clean) pressure drop is approximately 1 psi (6.9 kPa). Open the factory-installed blowdown valve to clean the strainer. If required, shut the chiller down and remove the strainer screen to clean. When strainer has been cleaned, enter 'YES' for strainer maintenance done (S.T.MN) [Run Status, PM].

Motormaster® V Controller — The optional or accessory Motormaster V controller uses a 0 to 5 vdc signal input from a pressure transducer attached to the liquid line service valve gage port on each circuit. See Fig. 37. The pressure transducer is connected to terminals 2, 5 and 6 on the controller. The controller is factory configured and requires no field programming. If a situation arises where the drive does not function properly, the information provided below and Table 37 can be used to troubleshoot the drive.

⚠ CAUTION

If input power has not been applied to the drive for a period of time exceeding three years (due to storage, etc.), the electrolytic DC bus capacitors within the drive can change internally, resulting in excessive leakage current. This can result in premature failure of the capacitors if the drive is operated after such a long period of inactivity or storage. In order to reform the capacitors and prepare the drive for operation after a long period of inactivity, apply input power to the drive for 8 hours prior to actually operating the motor. Before attempting to operate the drive, motor, and driven equipment, be sure all procedures pertaining to installation and wiring have been properly followed.

⚠ CAUTION

DO NOT connect incoming AC power to output terminals T1, T2, and T3! Severe damage to the drive will result. Do not continuously cycle input power to the drive more than once every two minutes. Damage to the drive will result.

⚠ WARNING

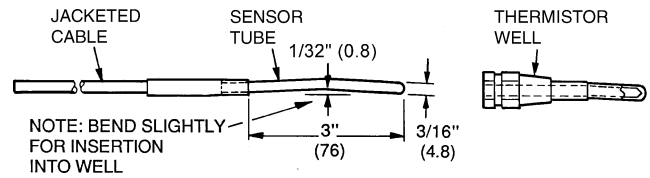
Hazard of electrical shock! Wait three minutes after disconnecting incoming power before servicing drive. Capacitors retain charge after power is removed. Drive assembly includes externally mounted current limiting resistors. Use extreme caution when servicing the drive.

⚠ WARNING

When configured as shown below, this equipment is designed to start when it receives line power. Ensure that all personnel are clear of fans and guards are installed before applying power.

GENERAL OPERATION — This control varies condenser fan speed based on liquid pressure. The control is a Variable Frequency Drive (VFD) and is only compatible with motors rated for use with VFDs. The accompanying pressure transducer has a 0 to 5 v output range corresponding to a -40 to 460 psi range. The VFD provides a 5 v output for the transducer on pin 6.

This system is a reverse acting, proportional-integral (PI) control. The VFD will vary the motor speed to drive the liquid line pressure to the set point during ambient temperatures below 60 F. The set point is lower than a normal operating pressure during summer operation. At higher ambient temperatures, the fan will go to full speed (60 Hz or 50 Hz depending on model) and remain there since it can not go fast enough to



FLUID-SIDE TEMPERATURE SENSORS (T1 AND T2)
NOTE: Dimensions in () are in millimeters.

Fig. 35 — Fluid-Side Temperature Sensors (T1 and T2)

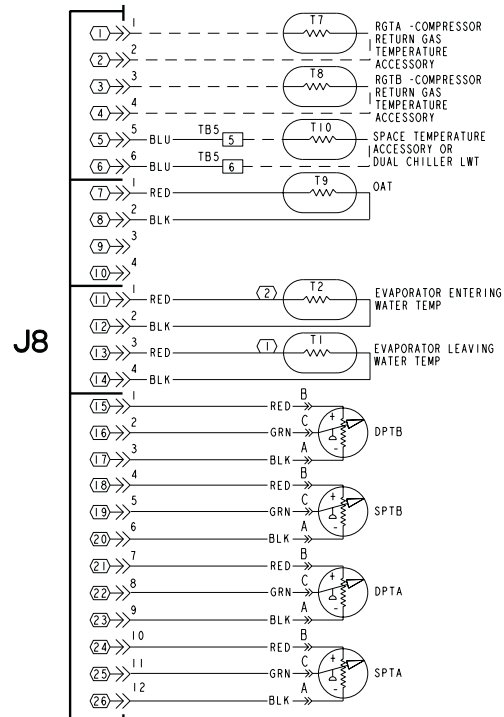


Fig. 36 — Thermistor Connections to Main Base Board, J8 Connector

bring the pressure down to the set point. When the VFD is at full speed, it acts just like a fixed speed fan.

When the ambient air temperature drops, a fan running at full speed draws too much air across the condenser coil to maintain a minimum condensing pressure/temperature. In these conditions, the VFD will slow down and begin to maintain a set point.

The VFD will display the set point as the default. The set point is displayed in speed as Hz and is configured by the start command jumper as detailed in Fig. 38.

Motormaster V control can also be configured to follow an external control system to perform the PI control functions. See configuration section for details.

The real-time feedback signal (liquid line pressure, in volts) is displayed by viewing parameter 69. The real-time output frequency is displayed by viewing parameter 71.

SET POINTS — Operating modes are configured for R-22 with a set point of 135 psig on the liquid line.

INSTALLATION — See Fig. 38 for transducer wiring to the VFD.

NOTE: The drive is phase insensitive with respect to incoming line voltage. This means that the VFD will operate with any phase sequence of the incoming three-phase voltage.

▲ CAUTION

It is strongly recommended that the user NOT change any programming without consulting Carrier service personnel. Unit damage may occur from improper programming.

Motormaster V control is completely configured according to the inputs provided. No additional programming is necessary.

The drive can display 71 program parameters. Parameters 50-60 are monitor functions and cannot be changed. The remainder of the parameters can be changed after entering a password.

To enter password and change program values:

1. Press **Mode**.
2. Upper right decimal point blinks.
3. Display reads "00" (see Fig. 37). To enter the PROGRAM mode to access the parameters, press the **Mode** button (see Fig. 37). This will activate the PASSWORD prompt (if the password has not been disabled). The display will read "00" and the upper right-hand decimal point will be blinking.
4. Use the ▲ and ▼ buttons to scroll to the password value (the factory default password is "111") and press the **Mode** button. Once the correct password value is entered, the display will read "P01", which indicates that the PROGRAM mode has been accessed at the beginning of the parameter menu (P01 is the first parameter).

NOTE: If the display flashes "Er", the password was incorrect, and the process to enter the password must be repeated.

5. Press **Mode** to display present parameter setting. Upper right decimal point blinks. Use the ▲ and ▼ buttons to scroll to the desired parameter number.

Once the desired parameter number is found, press the **Mode** button to display the present parameter setting. The upper right-hand decimal point will begin blinking, indicating that the present parameter setting is being displayed, and that it can be changed by using the up and down buttons. Use ▲ and ▼ to change setting. Press **Mode** to store new setting.

Pressing the **Mode** will store the new setting and also exit the PROGRAM mode. To change another parameter, press the **Mode** key again to re-enter the PROGRAM mode (the parameter menu will be accessed at the parameter that was last viewed or changed before exiting). If the **Mode** key is pressed within two minutes of exiting the PROGRAM mode, the password is not required access the parameters. After two minutes, the password must be entered in order to access the parameters again.

To change password: first enter the current password then change parameter P44 to the desired password.

To disable automatic control mode and enter manual speed control mode:

1. Change P05 to '01- keypad'.
2. Push UP and DOWN arrow key to set manual speed.
3. Set P05 to '05 - R22' to restore automatic control.

To provide manual start/stop control:

With power removed from VFD, remove start command jumper and install a switch between the appropriate start terminals as required in Fig 37.

EPM CHIP — The drive uses a electronic programming module (EPM) chip to store the program parameters. This is an EEPROM memory chip and is accessible from the front of the VFD. It should not be removed with power applied to the VFD.

LIQUID LINE PRESSURE SET POINT ADJUSTMENT — Adjusting the set point is not recommended due to possible interaction with other head pressure software algorithms or controls. In situations where the set point must be changed, the set point for R-22 is found in P34. A higher value will result in a higher liquid line set point. Example: increasing the factory default (P34) set point from 18.0 to 19.0 will increase the liquid line pressure by approximately 10 psi.

LOSS OF CCN COMMUNICATIONS — Carrier Comfort Network (CCN) communications with external control systems can be affected by high frequency electrical noise generated by the Motormaster V control. Ensure unit is well grounded to eliminate ground currents along communication lines.

If communications are lost only while Motormaster V control is in operation, order a signal isolator (CEAS420876-2) and power supplies (CEAS221045-01, 2 required) for the CCN communication line.

Fault Codes — The drive is programmed to automatically restart after a fault and will attempt to restart three times after a fault (the drive will not restart after CF, cF, GF, F1, F2-F9, or Fo faults). If all three restart attempts are unsuccessful, the drive will trip into FAULT LOCKOUT (LC), which requires a manual reset.

NOTE: Since faults may be reset as incoming power is cycled, you may need to observe current fault code before the Carrier unit control turns off the VFD. Most recent faults can be accessed using parameter 50. If necessary, remove start jumper and energize condenser fan contactor using Service Test. This will allow programming and access to fault history.

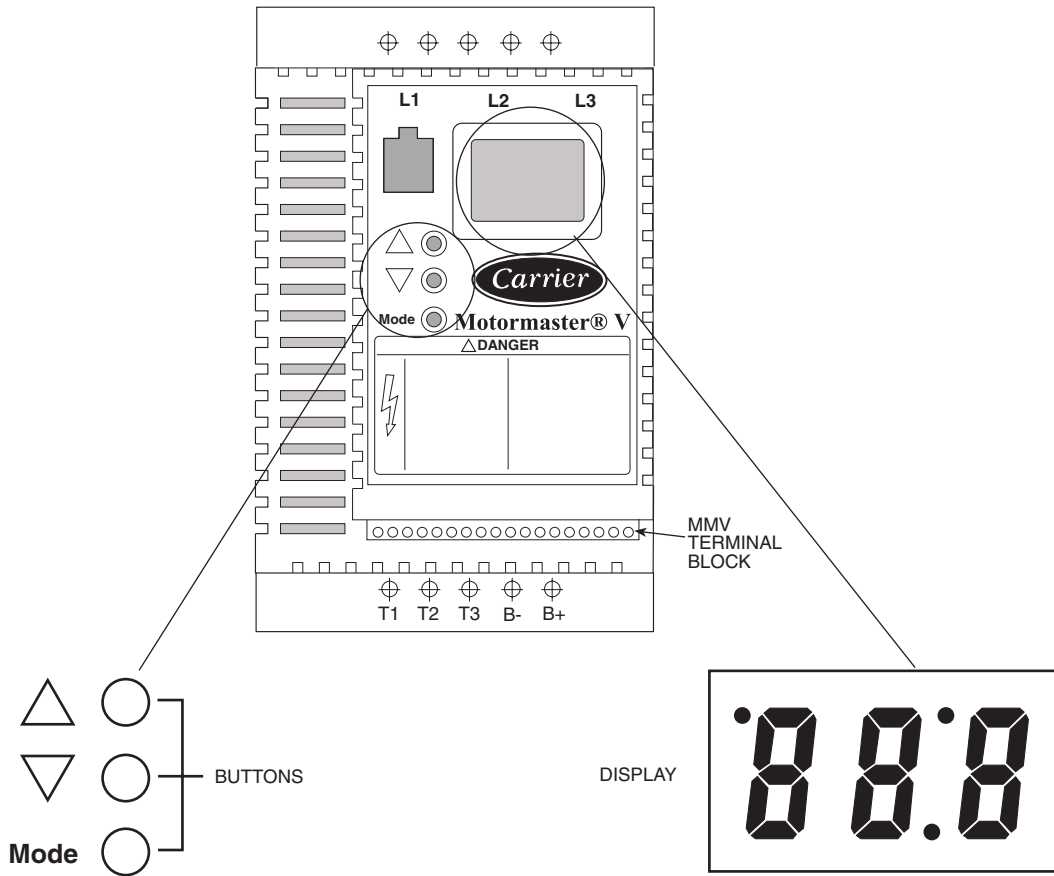
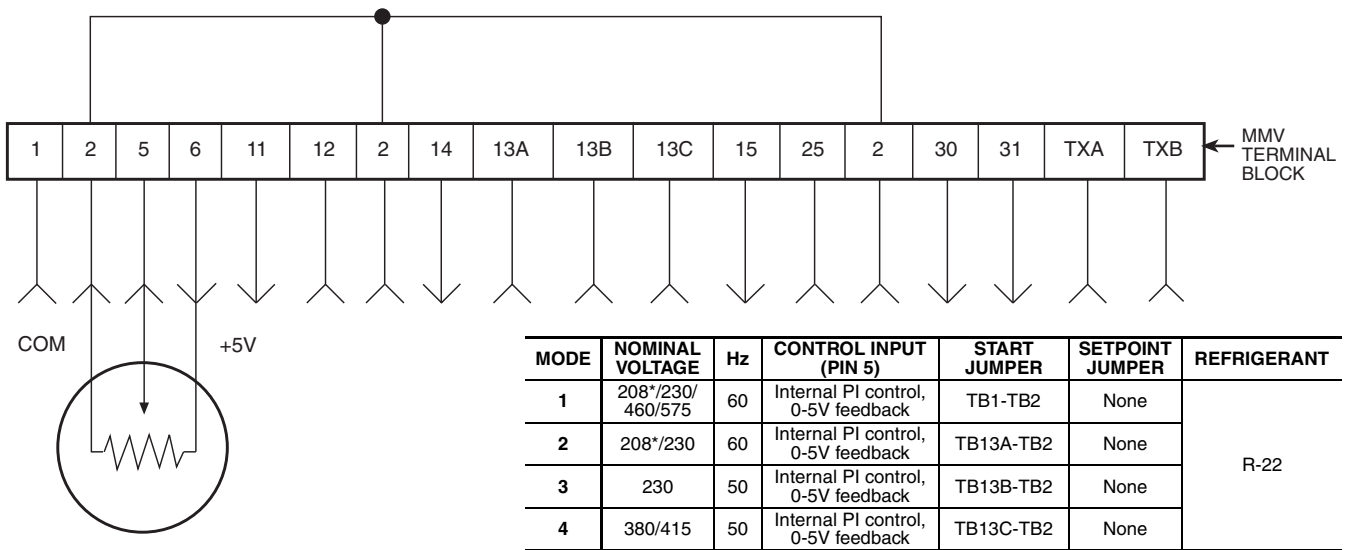


Fig. 37 — Motormaster® V Mode Buttons and Mode Display



*At 208 v, the drive can run in either mode.

Fig. 38 — Pressure Transducer and Start Command Jumper Wiring

Table 37 — Fault Codes

FAULT CODE	DESCRIPTION	SOLUTION
AF	High Temperature Fault: Ambient temperature is too high; Cooling fan has failed (if equipped).	Check cooling fan operation
CF	Control Fault: A blank EPM, or an EPM with corrupted data has been installed.	Perform a factory reset using Parameter 48 — PROGRAM SELECTION.
cF	Incompatibility Fault: An EPM with an incompatible parameter version has been installed.	Either remove the EPM or perform a factory reset (Parameter 48) to change the parameter version of the EPM to match the parameter version of the drive.
CL	CURRENT LIMIT: The output current has exceeded the CURRENT LIMIT setting (Parameter 25) and the drive is reducing the output frequency to reduce the output current. If the drive remains in CURRENT LIMIT too long, it can trip into a CURRENT OVERLOAD fault (PF).	Check for loose electrical connections. Check for faulty condenser fan motor. Check Parameter P25 from Table 38 is set correctly.
GF	Data Fault: User data and OEM defaults in the EPM are corrupted.	Restore factory defaults P48, see section above. If that does not work, replace EPM.
HF	High DC Bus Voltage Fault: Line voltage is too high; Deceleration rate is too fast; Overhauling load.	Check line voltage — set P01 appropriately
JF	Serial Fault: The watchdog timer has timed out, indicating that the serial link has been lost.	Check serial connection (computer) Check settings for PXX. Check settings in communication software to match PXX.
LF	Low DC Bus Voltage Fault: Line voltage is too low.	Check line voltage — set P01 appropriately
OF	Output Transistor Fault: Phase to phase or phase to ground short circuit on the output; Failed output transistor; Boost settings are too high; Acceleration rate is too fast.	Reduce boost or increase acceleration values. If unsuccessful, replace drive.
PF	Current Overload Fault: VFD is undersized for the application; Mechanical problem with the driven equipment.	Check line voltage — set P01 appropriately Check for dirty coils Check for motor bearing failure
SF	Single-phase Fault: Single-phase input power has been applied to a three-phase drive.	Check input power phasing
F1	EPM Fault: The EPM is missing or damaged.	
F2-F9, Fo	Internal Faults: The control board has sensed a problem	Consult factory
Drive display = 60.0 even though it is cold outside and it should be running slower	Feedback signal is above set point	Check for proper set point Check liquid line pressure
Drive display = '---' even though drive should be running	Start jumper is missing	Replace start jumper. See section above
Drive display = 8.0 even though fan should be running faster	Feedback signal is below set point and fan is at minimum speed	Check for proper set point Check liquid line pressure
VFD flashes 57 and LCS	Feedback or speed signal lost. Drive will operate at 57 Hz until reset or loss of start command. Resetting requires cycling start command (or power).	In stand alone mode: Check transducer wiring and feedback voltage. Feedback voltage displayed on P-69. Pin 6 should be 5 v output. Pin 5 (feedback) should be somewhere between 0 and 5 v.

Manual Reset — If fault condition has been removed, cycle power to the chiller to reset the VFD.

Troubleshooting — Troubleshooting the Motormaster® V control requires a combination of observing system operation and VFD information. The drive provides 2 kinds of troubleshooting modes: a status matrix using the 3-digit display (P57, P58) and real time monitoring of key inputs and outputs. The collective group is displayed through parameters 50-60 and all values are read-only.

- **P50: FAULT HISTORY** — Last 8 faults
- **P51: SOFTWARE version**
- **P52: DC BUS VOLTAGE** — in percent of nominal. Usually rated input voltage x 1.4
- **P53: MOTOR VOLTAGE** — in percent of rated output voltage

- **P54: LOAD** — in percent of drives rated output current rating
- **P55: VDC INPUT** — in percent of maximum input: 100 will indicate full scale which is 5 v
- **P56 4-20 mA INPUT** — in percent of maximum input. 20% = 4 mA, 100% = 20 mA

Manual Starter Trip — If the VFD manual starter (MS-FC-HS, MS-FC-A1 or MS-FC-B1 depending on model) trips, locate the inrush current protectors (3 round black disks per motor) and verify their resistance. For units operating at 208 v or 230 v, these devices should measure approximately 7 ohms. For all other voltages, they should measure approximately 20 ohms. Check value with mating plug disconnected, power to chiller off and at ambient temperature (not hot immediately after stopping VFD). These are standard resistances at 77 F (25 C). Resistance values decrease at higher temperatures and increase at lower temperatures.

Table 38 — Motormaster® V Program Parameters for Operating Modes

PARAMETERS	DESCRIPTION	MODE 1	MODE 2	MODE 3	MODE 4
P01	Line Voltage: 01 = low line, 02 = high line	01	02	01	02
P02	Carrier Freq: 01 = 4 kHz, 02 = 6 kHz, 03 = 8 kHz	01	01	01	01
P03	Startup mode: flying restart	06	06	06	06
P04	Stop mode: coast to stop	01	01	01	01
P05	Standard Speed source: 01= keypad, 04=4-20mA (NO PI), 05= R22, 06=R134a	05	05	05	05
P06	TB-14 output: 01 = none	01	01	01	01
P08	TB-30 output: 01 = none	01	01	01	01
P09	TB-31 Output: 01 = none	01	01	01	01
P10	TB-13A function sel: 01 = none	01	01	01	01
P11	TB-13B function sel: 01 = none	01	01	01	01
P12	TB-13C function sel: 01 = none	01	01	01	01
P13	TB-15 output: 01 = none	01	01	01	01
P14	Control: 01 = Terminal strip	01	01	01	01
P15	Serial link: 02 = enabled 9600,8,N,2 with timer	02	02	02	02
P16	Units editing: 02 = whole units	02	02	02	02
P17	Rotation: 01 = forward only, 03 = reverse only	01	01	01	01
P19	Acceleration time: 10 sec	10	10	10	10
P20	Deceleration time: 10 sec	10	10	10	10
P21	DC brake time: 0	0	0	0	0
P22	DC BRAKE VOLTAGE 0%	0	0	0	0
P23	Min freq = 8 Hz ~ 100 – 160 rpm	8	8	8	8
P24	Max freq	60	60	50	50
P25	Current limit: (%)	125	110	125	110
P26	Motor overload: 100	100	100	100	100
P27	Base freq: 60 or 50 Hz	60	60	50	50
P28	Fixed boost: 0.5% at low frequencies	0.5	0.5	0.5	0.5
P29	Accel boost: 0%	0	0	0	0
P30	Slip compensation: 0%	0	0	0	0
P31	Preset spd #1: speed if loss of control signal	57	57	47	47
P32	Preset spd #2: 0	0	0	0	0
P33	Preset spd #3: 0	0	0	0	0
P34	Preset spd 4 default — R22 set point. TB12-2 open	18.0	18.0	18.0	18.0
P35	Preset spd 5 default — R134a set point. TB12-2 closed	12.6	12.6	12.6	12.6
P36	Preset spd 6 default	0	0	0	0
P37	Preset spd 7 default	0	0	0	0
P38	Skip bandwidth	0	0	0	0
P39	Speed scaling	0	0	0	0
P40	Frequency scaling 50 or 60 Hz	60	60	50	50
P41	Load scaling: default (not used so NA)	200	200	200	200
P42	Accel/decel #2: default (not used so NA)	60	60	60	60
P43	Serial address	1	1	1	1
P44	Password:111	111	111	111	111
P45	Speed at min signal: 8 Hz: used when PID mode is disabled and 4-20mA input is at 4 mA	8	8	8	8
P46	Speed at max feedback: 60 or 50 Hz. Used when PID disabled and 4-20mA input is at 20 mA	60	60	50	50
P47	Clear history? 01 = maintain. (set to 02 to clear)	01	01	01	01
P48	Program selection: Program 1 – 12	01	02	03	04
P61	PI Mode: 05= reverse, 0-5V, 01 = no PID	05	05	05	05
P62	Min feedback = 0 (0V *10)	0	0	0	0
P63	Max feedback = 50 (5V * 10)	50	50	50	50
P64	Proportional gain = 4%	4	4	4	4
P65	Integral gain = .2	.2	.2	.2	.2
P66	PI accel/decel (set point change filter) = 5	5	5	5	5
P67	Min alarm	0	0	0	0
P68	Max alarm	0	0	0	0

LEGEND

- NA — Not Applicable
- PID — Proportional Integral Derivative
- TB — Terminal Block

REPLACING DEFECTIVE MODULES — The *Comfort-Link™* replacement modules are shown in Table 39. If the Main Base Board (MBB) has been replaced, verify that all configuration data is correct. Follow the Configuration mode table and verify that all items under sub-modes UNIT, OPT1 and OPT2 are correct. Any additional field-installed accessories or options (RSET, SLCT sub-modes) should also be verified as well as any specific time and maintenance schedules.

Refer to the Start-Up Checklist for 30RA Liquid Chillers (completed at time of original start-up) found in the job folder. This information is needed later in this procedure. If the checklist does not exist, fill out the current information in the Configuration mode on a new checklist. Tailor the various options and configurations as needed for this particular installation.

⚠ CAUTION
Electrical shock can cause personal injury. Disconnect all electrical power before servicing.

1. Check that all power to unit is off. Carefully disconnect all wires from the defective module by unplugging its connectors.
2. Remove the defective module by removing its mounting screws with a Phillips screwdriver, and removing the module from the control box. Save the screws later use.
3. Verify that the instance jumper (MBB) or address switches (all other modules) exactly match the settings of the defective module.

NOTE: Handle boards by mounting standoffs only to avoid electrostatic discharge.

4. Package the defective module in the carton of the new module for return to Carrier.
5. Mount the new module in the unit's control box using a Phillips screwdriver and the screws saved in Step 2.
6. Reinstall all module connectors. For accessory Navigator replacement, make sure the plug is installed at TB3 in the LEN connector.
7. Carefully check all wiring connections before restoring power.
8. Verify the ENABLE/OFF/REMOTE CONTACT switch is in the OFF position.
9. Restore control power. Verify that all module red LEDs blink in unison. Verify that all green LEDs are blinking and that the Scrolling Marquee or Navigator display is communicating correctly.
10. Verify all configuration information, settings, set points and schedules. Return the ENABLE/OFF/REMOTE CONTACT switch to its previous position.

Table 39 — Replacement Modules

MODULE	REPLACEMENT PART NO. (with Software)	REPLACEMENT PART NO. (without Software)
Main Base Board (MBB)	30RA501102	HK50AA029
Scrolling Marquee Display	HK50AA031	HK50AA030
Energy Management Module (EMM)	30GT515218	HK50AA028
Navigator Display	HK50AA033	N/A

Hydronic Package — If the unit is equipped with a factory-installed hydronic package, consult the information below for proper maintenance and service. In addition to this

information, each factory-installed hydronic package is supplied with a packet of information supplied by the manufacturer, Bell & Gossett. Carrier Corporation strongly recommends that this information be thoroughly reviewed prior to operation of the chiller.

PUMP PERFORMANCE CHECK — The factory-installed pumps in the 30RA units are shipped with a single impeller size available for that pump. The pump was selected based on the flow and head requirements as provided to Carrier. It is not uncommon for actual pump duty to be different than what was anticipated at time of selection. In many cases, it may be desirable to make some field modifications to obtain optimum pump performance.

Before any pump modifications are made, it is recommended that actual pump performance be verified and compared to the applicable pump curve. See base unit installation instructions. This can be done in a variety of ways:

1. If pump impeller diameter is known:
 - a. Connect a differential pressure gage across the pump at the ports provided on the pump volutes.
 - b. Read GPM from applicable impeller curve.

2. If pump impeller diameter is not known:

If pump impeller diameter has been trimmed and the size is not known, it is necessary to determine which impeller curve to read.

The easiest way to confirm pump performance is to “dead-head” the pump and read the differential pressure across the pressure ports on the pump. “Dead-heading” can be done by shutting the circuit setter valve on the discharge side of the pump.

NOTE: Although not all pumps can be safely “dead-headed”, centrifugal pumps (such as on the 30RA units) can be “dead-headed” for short amounts of time. It is recommended to keep the time short due to excessive heat build-up in the pump.

Since the “dead-head” condition is a no-flow condition, the head will correspond to the intersection of an impeller curve with the vertical axis of the pump chart. The correct impeller diameter is that which corresponds to the measured head.

3. Once the impeller diameter is known, proceed as in Step 1.
4. Water flow rate can be determined by using a differential pressure gage with the Bell & Gossett circuit setter balance valve calculator. (This information is also provided in the installation instructions.) This method will not directly measure pressure differential seen by the pump, but can be used to “double-check” the pump measurement.
5. Verify that cable connections at the switch and at the terminal block are secure.
6. For factory-installed hydronic system, verify that:
 - All air has been purged from the system.
 - Circuit setter balance valve has been correctly set.
7. Pump impeller has been improperly trimmed and is not providing sufficient flow.
8. Wrong pump motor rotation. Pump must rotate clockwise when viewed from motor end of pump.

PUMP MODIFICATIONS AND IMPELLER TRIMMING — See applicable section in the Installation instructions.

RESET OF CHILLER WATER FLOW — See applicable section in the Installation instructions.

CHANGING OF PUMP SEALS — See Bell & Gossett service instruction manual provided with the hydronic package.

MAINTENANCE

Recommended Maintenance Schedule — The following are only recommended guidelines. Jobsite conditions may dictate that maintenance schedule is performed more often than recommended.

Routine:

For machines with E-coat Condenser Coils:

- Check condenser coils for debris, clean as necessary with Carrier approved coil cleaner.
- Periodic clean water rinse, especially in coastal and industrial applications.

Every month:

- Check condenser coils for debris, clean as necessary with Carrier approved coil cleaner.
- Check moisture indicating sight glass for possible refrigerant loss and presence of moisture.

Every 3 months (for all machines):

- Check refrigerant charge.
- Check all refrigerant joints and valves for refrigerant leaks, repair as necessary.
- Check chilled water flow switch operation.
- Check condenser coils for debris, clean as necessary with Carrier approved coil cleaner.
- Check all condenser fans for proper operation.
- Check compressor oil level.
- Check crankcase heater operation.

Every 12 months (for all machines):

- Check all electrical connections, tighten as necessary.
- Inspect all contactors and relays, replace as necessary.
- Check accuracy of thermistors, replace if greater than $\pm 2^\circ\text{F}$ (1.2°C) variance from calibrated thermometer.
- Obtain and test an oil sample. Change oil only if necessary.
- Check to be sure that the proper concentration of anti-freeze is present in the chilled water loop, if applicable.
- Verify that the chilled water loop is properly treated.
- Check refrigerant filter driers for excessive pressure drop, replace as necessary.
- Check chilled water strainers, clean as necessary.
- Check cooler heater operation, if equipped.
- Check condition of condenser fan blades and that they are securely fastened to the motor shaft.
- Perform Service Test to confirm operation of all components.
- Check for excessive cooler approach (Leaving Chilled Water Temperature — Saturated Suction Temperature) which may indicate fouling. Clean cooler vessel if necessary.

PRE-START-UP

IMPORTANT: Before beginning Pre-Start-Up or Start-Up, complete Start-Up Checklist for 30RA Liquid Chiller at end of this publication (page CL-1 to CL-8). The Checklist assures proper start-up of a unit, and provides a record of unit condition, application requirements, system information, and operation at initial start-up.

Do not attempt to start the chiller until following checks have been completed.

System Check

1. Check all auxiliary components, such as chilled fluid pumps, air-handling equipment, or other equipment to which the chiller supplies liquid. Consult manufacturer's instructions. Verify that any pump interlock contacts have been properly installed. If the unit has

field-installed accessories, be sure all are properly installed and wired correctly. Refer to unit wiring diagrams.

2. Use the Scrolling Marquee display to adjust the Cooling Set Point.
3. Fill chilled fluid circuit with clean water (with recommended inhibitor added) or other non-corrosive fluid to be cooled. Bleed all air out of the high points of the system. If chilled water is to be maintained at a temperature below 40 F (4.4 C) or outdoor temperatures are expected to be below 32 F (0° C), a brine of sufficient concentration must be used to prevent freeze-up at anticipated suction temperatures. See Table 40.
4. Check tightness of all electrical connections.
5. Oil should be visible in the compressor sightglass(es). See Fig. 39. An acceptable oil level in the compressors is from $\frac{1}{4}$ to $\frac{3}{4}$ of sight glass. Adjust the oil level as required. See Check Oil Charge section on page 60 for Carrier approved oils.
6. Electrical power source must agree with unit nameplate.
7. All condenser fan and factory installed hydronic package pump motors are three phase. Check for proper rotation of condenser fans first BEFORE attempting to start pumps or compressors. To reverse rotation, interchange any two of the main incoming power leads.
8. Be sure system is fully charged with refrigerant (see Check Refrigerant Charge section on page 75).
9. If unit is a brine unit, check to ensure proper brine concentration is used to prevent freezing.
10. Verify proper operation of cooler and hydronic package heaters (if installed). Heaters operate at the same voltage as the main incoming power supply and are single phase. Heater current is approximately .4 amps for 380, 400, 460 and 575 v units. Heater current is approximately .8 amps for 230 v units.

Table 40 — Minimum Cooler Flow Rates and Minimum Loop Volume

UNIT SIZE 30RA	COOLER MINIMUM FLOW		MINIMUM COOLER LOOP VOLUME	
	Gpm	L/s	Gal.	L
010	12	.76	40	151.2
015	16	1.01	55	207.9
018	19	1.20	48	181.4
022	26	1.64	65	245.7
025	29	1.83	71	268.3
030	33	2.08	82	309.3
035	42	2.65	102	393.1
040	45	2.80	113	449.8
042	48	3.02	119	427.1
045	52	3.28	129	487.6
050	57	3.59	142	536.6
055	65	4.10	163	616.1

START-UP AND OPERATION

NOTE: Refer to Start-Up Checklist on pages CL-1 to CL-8.

Actual Start-Up — Actual start-up should be done only under supervision of a qualified refrigeration mechanic.

1. Be sure all service valves are open.
2. Using the Scrolling Marquee display, set leaving-fluid set point (CSP.1) [Set Point, COOL]. No cooling range adjustment is necessary.
3. Start chilled fluid pump (if not configured for cooler pump control).
4. Turn ENABLE/OFF/REMOTE CONTACT switch to ENABLE position.

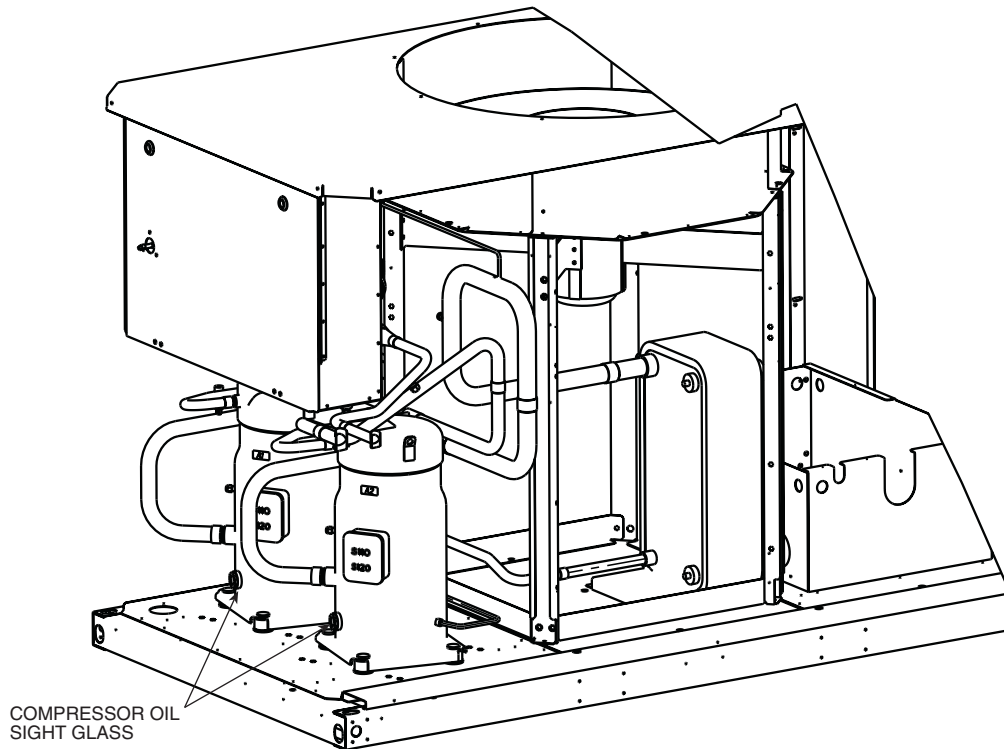


Fig. 39 — Compressor Connections and Oil Sight Glass Location

5. Allow unit to operate and confirm that everything is functioning properly. Check to see that leaving fluid temperature agrees with leaving set point (CSP.1 or CSP.2), or if reset is used, with the control point (CTPT) [Run Status, VIEW].
6. Check the cooler leaving chilled water temperature to see that it remains well above 32 F (0° C), or the brine freezing point if the unit is a medium temperature brine unit.
7. Recheck compressor oil level (see Check Oil Charge section).

Check Refrigerant Charge — All 30RA units are shipped with a complete operating charge of R-22 and should be under sufficient pressure to conduct a leak test after installation. If there is no system pressure, admit nitrogen until a pressure is observed and then proceed to test for leaks. After leaks are repaired, the system must be dehydrated.

All refrigerant charging should be done through the 1/4-in. Schraeder connection on the liquid line. Do NOT add refrigerant charge through the low-pressure side of the system. If complete charging is required, weigh in the appropriate charge for the circuit as shown on the unit nameplate. If partial charging is required, operate circuit at full load and use an accurate temperature sensor on the liquid line as it enters the TXV. Use the Temperatures mode on the Scrolling Marquee display to show the circuit saturated condensing temperature (SCT.A or SCT.B). Charging is most accurate at saturated discharge temperatures of 120 to 125 F (49 to 52 C). Block condenser airflow as required to reach this temperature range. Add refrigerant until the system subcooling (SCT.A or SCT.B minus liquid line temperature entering TXV) is approximately 15 to 17 F (-9.4 to -8.3 C). Refrigerant VAPOR only may be added to a circuit through the 1/4-in. suction Schraeder connection on the compressor. This connection is located in line and to the left of the compressor junction box for the SM110 compressors and to the

lower right of the compressor junction box for all other compressor models.

⚠ CAUTION

Never charge liquid into low-pressure side of system. Do not overcharge. Overcharging results in higher discharge pressure, possible compressor damage, and higher power consumption. During charging or removal of refrigerant, be sure water is continuously circulating through the cooler to prevent freezing. Damage caused by freezing is considered abuse and may void the Carrier warranty.

Operating Limitations

TEMPERATURES (See Table 41 for 30RA Standard Temperature Limits)

⚠ CAUTION

Do not operate with cooler leaving chiller water (fluid) temperature (LCWT) below 40 F (4.4 C) for the standard units, or below 15 F (-9.4 C) for units factory built for medium temperature brine.

High Cooler Leaving Chilled Water (Fluid) Temperatures (LCWT) — During start-up with cooler LCWT above approximately 60 F (16 C), the unit expansion valve will limit suction pressure to approximately 90 psig (620 kPa) to avoid overloading the compressor.

Low Cooler LCWT — For standard units, the LCWT must be no lower than 40 F (4.4 C). If the unit is the factory-installed optional medium temperature brine unit, the cooler LCWT can go down to 15 F (-9.4 C).

Table 41 — Temperature Limits for Standard 30RA Units

UNIT SIZE 30RA Temperature	010-030		032-055	
	F	C	F	C
Maximum Ambient Temperature	120	49	120	49
Minimum Ambient Temperature	45	7	32	0
Maximum Cooler EWT*	95	35	95	35
Maximum Cooler LWT	70	21	70	21
Minimum Cooler LWT†	40	4.4	40	4.4

LEGEND

EWT — Entering Fluid (Water) Temperature
LWT — Leaving Fluid (Water) Temperature

*For sustained operation, EWT should not exceed 85 F (29.4 C).
†Unit requires modification below this temperature.

LOW-AMBIENT OPERATION — If operating temperatures below 45 F (7 C) for sizes 010-030 or below 32 F (0° C) for sizes 032-055 are expected, accessory Motormaster® V control must be installed. Refer to separate installation instructions for operation using this accessory. Contact your Carrier representative for details.

⚠ CAUTION

Brine duty application (below 40 F [4.4 C] LCWT) for chiller normally requires factory modification. Contact your Carrier representative for applicable LCWT range for standard water-cooled chiller in a specific application.

VOLTAGE — ALL UNITS

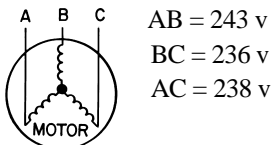
Main Power Supply — Minimum and maximum acceptable supply voltages are listed in the Installation Instructions.

Unbalanced 3-Phase Supply Voltage — *Never operate a motor where a phase imbalance between phases is greater than 2%.* To determine percent voltage imbalance:

$$\% \text{ Voltage Imbalance} = 100 \times \frac{\text{max voltage deviation from avg voltage}}{\text{average voltage}}$$

The maximum voltage deviation is the largest difference between a voltage measurement across 2 legs and the average across all 3 legs.

Example: Supply voltage is 240-3-60.



AB = 243 v
BC = 236 v
AC = 238 v

1. Determine average voltage:

$$\begin{aligned} \text{Average voltage} &= \frac{243 + 236 + 238}{3} \\ &= \frac{717}{3} \\ &= 239 \end{aligned}$$

2. Determine maximum deviation from average voltage:

$$\begin{aligned} (\text{AB}) \quad &243 - 239 = 4 \text{ v} \\ (\text{BC}) \quad &239 - 236 = 3 \text{ v} \\ (\text{AC}) \quad &239 - 238 = 1 \text{ v} \end{aligned}$$

Maximum deviation is 4 v.

3. Determine percent voltage imbalance:

$$\begin{aligned} \% \text{ Voltage Imbalance} &= 100 \times \frac{4}{239} \\ &= 1.7\% \end{aligned}$$

This voltage imbalance is satisfactory as it is below the maximum allowable of 2%.

IMPORTANT: If the supply voltage phase imbalance is more than 2%, contact your local electric utility company immediately. Do not operate unit until imbalance condition is corrected.

Control Circuit Power — Power for the control circuit is supplied from the main incoming power through a factory-installed control power transformer (TRAN1) for all models. Field wiring connections are made to either terminal block TB5 or TB6.

OPERATION SEQUENCE

During unit off cycle, the control monitors the outdoor air temperature. If the ambient temperature drops below 40 F (4.4 C), cooler and hydronic system heaters (if either are factory installed) are energized. If power is maintained to the chiller and the EMERGENCY ON/OFF switch is left in the OFF position, these heaters are also energized.

The unit is started by putting the ENABLE/OFF/REMOTE CONTACT switch in the ENABLE or REMOTE CONTACT position. When the unit receives a call for cooling (either from the internal control or CCN network command or remote contact closure), the unit stages up in capacity to maintain the leaving fluid set point. The first compressor starts 1½ to 3 minutes after the call for cooling.

The lead circuit can be specifically designated on all models or selected based on compressor run hours and starts depending on field configuration. The unit control will override this selection under certain starting conditions to properly maintain oil return to the compressors. In general, on dual compressor circuits, the control will most often start the A1 or B1 compressor first, especially after long off periods. The MBB controls fan stages to maintain the head pressure set point and will automatically adjust unit capacity as required to keep compressors from operating outside of the specified envelope. There are no pumpout or pumpdown sequences on these chillers.

For all units, if temperature reset is being used, the unit controls to a higher leaving-fluid temperature as the building load reduces. If demand limit is used, the unit may temporarily be unable to maintain the desired leaving-fluid temperature because of imposed power limitations. Loading sequence for compressors is shown in Tables 6 and 7.

APPENDIX A

CCN Tables

A_UNIT (General Unit Parameters)

DESCRIPTION	VALUE	UNITS	POINT NAME	FORCEABLE
Control Mode	0 = Test 1 = Local Off 2 = CCN Off 3 = Clock Off 4 = Emergency Stop 5 = Local On 6 = CCN On 7 = Clock On 8 = Heat Enabled 9 = Pump Delay		STAT	N
Occupied	No/Yes		OCC	N
CCN Chiller	Start/Stop		CHIL_S_S	Y
Low Sound Active	No/Yes		LSACTIVE	N
Alarm State	Normal/Alert/Alarm		ALM	N
Active Demand Limit	0 to 100	%	DEM_LIM	Y
Override Modes in Effect	No/Yes		MODE	N
Percent Total Capacity	0 to 100	%	CAP_T	N
Requested Stage	0 to 99		STAGE	N
Active Set Point	-20 to 70	°F	SP	N
Control Point	-20 to 70	°F	CTRL_PNT	Y
Entering Fluid Temp	snnn.n	°F	EWT	N
Leaving Fluid Temp	snnn.n	°F	LWT	N
Emergency Stop	Enable/Emstop	Enable	EMSTOP	Y
Minutes Left for Start	00:00 to 15:00	minutes	MIN_LEFT	N
PUMPS				
Cooler Pump Relay 1	Off/On		COOLPMP1	N
Cooler Pump Relay 2	Off/On		COOLPMP2	N
Cooler Pump 1 Interlock	Open/Close		PMP1_FBK	N
Cooler Pump 2 Interlock	Open/Close		PMP2_FBK	N
Cooler Flow Switch	Open/Close		COOLFLOW	N
Rotate Cooler Pumps Now	No/Yes		ROT_PUMP	
Heat/Cool Select	Heat/Cool		HC_SEL	N

CIRCADIO (Circuit A Discrete Inputs/Outputs)

DESCRIPTION	VALUE	UNITS	POINT NAME	FORCEABLE
CIRC. A DISCRETE OUTPUTS				
Compressor A1 Relay	On/Off		K_A1_RLY	N
Compressor A2 Relay	On/Off		K_A2_RLY	N
Minimum Load Valve Relay	On/Off		MLV_RLY	N
CIRC. A DISCRETE INPUTS				
Compressor A1 Feedback	On/Off		K_A1_FBK	N
Compressor A2 Feedback	On/Off		K_A2_FBK	N

CIRCA_AN (Circuit A Analog Parameters)

DESCRIPTION	VALUE	UNITS	POINT NAME	FORCEABLE
CIRCUIT A ANALOG VALUES				
Percent Total Capacity	0-100	%	CAPA_T	N
Percent Available Cap.	0-100	%	CAPA_A	N
Discharge Pressure	nnn.n	PSIG	DP_A	N
Suction Pressure	nnn.n	PSIG	SP_A	N
Calculated HP Setpoint A	nnn.n	°F	HSP_A	N
Saturated Condensing Tmp	snnn.n	°F	TMP_SCTA	N
Saturated Suction Temp	snnn.n	°F	TMP_SSTA	N
Compr Return Gas Temp	snnn.n	°F	TMP_RGTA	N
Suction Superheat Temp	snnn.n	ΔF	SH_A	N

CIRCB DIO (Circuit B Discrete Inputs/Outputs)

DESCRIPTION	VALUE	UNITS	POINT NAME	FORCEABLE
CIRC. B DISCRETE OUTPUTS				
Compressor B1 Relay	On/Off		K_B1_RLY	N
Compressor B2 Relay	On/Off		K_B2_RLY	N
Minimum Load Valve Relay	On/Off		MLV_RLY	N
CIRC. B DISCRETE INPUTS				
Compressor B1 Feedback	On/Off		K_B1_FBK	N
Compressor B2 Feedback	On/Off		K_B2_FBK	N

CIRCB_AN (Circuit B Analog Parameters)

DESCRIPTION	VALUE	UNITS	POINT NAME	FORCEABLE
CIRCUIT B ANALOG VALUES				
Percent Total Capacity	0-100	%	CAPB_T	N
Percent Available Cap.	0-100	%	CAPB_A	N
Discharge Pressure	nnn.n	PSIG	DP_B	N
Suction Pressure	nnn.n	PSIG	SP_B	N
Calculated HP Setpoint B	nnn.n	°F	HSP_B	N
Saturated Condensing Tmp	snnn.n	°F	TMP_SCTB	N
Saturated Suction Temp	snnn.n	°F	TMP_SSTB	N
Compr Return Gas Temp	snnn.n	°F	TMP_RGTB	N
Suction Superheat Temp	snnn.n	ΔF	SH_B	N

OPTIONS (Unit Parameters)

DESCRIPTION	VALUE	UNITS	POINT NAME	FORCEABLE
FANS				
Fan 1 Relay	Off/On		FAN_1	N
Fan 2 Relay	Off/On		FAN_2	N
Cooler/Pump Heater	Off/On		COOL_HTR	N
UNIT ANALOG VALUES				
Cooler Entering Fluid	snnn.n	°F	COOL_EWT	N
Cooler Leaving Fluid	snnn.n	°F	COOL_LWT	N
Lead/Lag Leaving Fluid	snnn.n	°F	DUAL_LWT	N
TEMPERATURE RESET				
4-20 mA Reset Signal	nn.n	mA	RST_MA	N
Outside Air Temperature	snnn.n	°F	OAT	Y
Space Temperature	snnn.n	°F	SPT	Y
DEMAND LIMIT				
4-20 mA Demand Signal	nn.n	mA	LMT_MA	N
Demand Limit Switch 1	Off/On		DMD_SW1	N
Demand Limit Switch 2	Off/On		DMD_SW2	N
CCN Loadshed Signal	0 = Normal 1 = Redline 2 = Loadshed		DL_STAT	N
MISCELLANEOUS				
Heat Request	Off/On		HEAT_REQ	N
Dual Setpoint Switch	Off/On		DUAL_IN	N
Cooler LWT Setpoint	snnn.n	°F	LWT_SP	N
Ice Done	Off/On		ICE_DONE	N

ALARMDEF (Alarm Definition Table)

DESCRIPTION	VALUE	DEFAULT	UNITS	POINT NAME
Alarm Routing Control	00000000	00000000		ALRM_CNT
Equipment Priority	0 to 7	4		EQP_TYPE
Comm Failure Retry Time	1 to 240	10	min	RETRY_TM
Re-alarm Time	1 to 255	30	min	RE-ALARM
Alarm System Name	XXXXXXXX	CHILLER		ALRM_NAM

BRODEFS (Broadcast POC Definition Table)

DESCRIPTION	VALUE	DEFAULT	UNITS	POINT NAME
CCN Time/Date Broadcast	Yes/No	No		CCNBC
CCN OAT Broadcast	Yes/No	No		OATBC
Global Schedule Broadcast	Yes/No	No		GSBC
CCN Broadcast Ack'er	Yes/No	No		CCNBCACK
Daylight Savings Start:				
Month	1 to 12	4		STARTM
Week	1 to 5	1		STARTW
Day	1 to 7	7		STARTD
Minutes to Add	0 to 99	60	min	MINADD
Daylight Savings Stop				
Month	1 to 12	10		STOPM
Week	1 to 5	5		STOPW
Day	1 to 7	7		STOPD
Minutes to Subtract	0 to 99	60	min	MINSUB

DISPLAY (Marquee Display SETUP)

DESCRIPTION	VALUE	DEFAULT	UNITS	POINT NAME
Service Password	nnnn	1111		PASSWORD
Password Enable	Enable/Disable	Enable		PASS_EBL
Metric Display	Off/On	Off		DISPUNIT
Language Selection	0 = ENGLISH 1 = FRANCAIS 2 = ESPANOL 3 = PORTUGUES	0		LANGUAGE

DUALCHIL (Dual Chiller Configuration Settings)

DESCRIPTION	VALUE	DEFAULT	UNITS	POINT NAME
LEAD/LAG				
Lead/Lag Chiller Enable	Enable/Dsable	Dsable		LL_ENA
Master/Slave Select	Master/Slave	Master		MS_SEL
Slave Address	0 to 239	2		SLV_ADDR
Lead/Lag Balance Select	0 = None	0		LL_BAL
Lead/Lag Balance Delta	40 to 400	168	hours	LL_BAL_D
Lag Start Delay	0 to 30	5	minutes	LL_DELAY
Parallel Configuration	Yes	Yes		PARALLEL

OPTIONS1 (Options 1 Configuration)

DESCRIPTION	VALUE	DEFAULT	UNITS	POINT NAME
Cooler Fluid	1 = Water 2 = Med. Brine	1		FLUIDTYP
Minimum Load Vlv Select	No/Yes	No		MLV_FLG
Return Gas Sensor Enable	Dsable/Enable	Dsable		RGT_ENA
Motormaster Select	No/Yes	No		MTR_TYPE
Cooler Pump Control	Off/On	Off		CPC
Cooler Pump 1 Enable	No/Yes	No		PMP1_ENA
Cooler Pump 2 Enable	Dsable/Enable	Dsable		PMP2_ENA
Cooler Pmp Periodic Strt	No/Yes	No		PUMP_PST
Cooler Pump Select	0 = Automatic 1 = Pump 1 2 = Pump 2	0		PMP_SLCT
Cooler Pump Shutdown Dly	0 to 10	1	minutes	PUMP_DLY
Pump Changeover Hours	10 to 2000	500	hours	PMP_DLTA
EMM Module Installed	No/Yes	No		EMM_BRD

OPTIONS2 (Options 2 Configuration)

DESCRIPTION	VALUE	DEFAULT	UNITS	POINT NAME
Control Method	0 = Switch 2 = Occupancy 3 = CCN	0		CONTROL
Loading Sequence Select	1 = Equal Loading 2 = Staged Loading	1		SEQ_TYP
Lead/Lag Circuit Select	0 = Automatic 1 = Circuit A Leads 2 = Circuit B Leads	0		LEAD_TYP
Cooling Setpoint Select	0 = Single 1 = Dual, remote switch controlled 2 = Dual CCN occupancy 3 = 4-20 mA input	0		CLSP_TYP
Ramp Load Select	Enable/Dsable	Enable		RAMP_EBL
Heat Cool Select	Cool/Heat	Cool		HEATCOOL
High LCW Alert Limit	2 to 60	60.0	ΔF	LCW_LMT
Minutes off time	0 to 15	0	min	DELAY
Deadband Multiplier	1.0 to 4.0	2.0		Z_GAIN
Ice Mode Enable	Enable/Dsable	Dsable		ICE_CNFG
Close Control Select	Enable/Dsable	Dsable		CLS_CTRL
Low Sound Mode Select	0 = Disabled 1 = Fan only 2 = Capacity/Fans	1		LS_MODE
Low Sound Start Time	00:00 to 23:59	00:00		LS_START
Low Sound End Time	00:00 to 23:59	00:00		LS_END
Low Sound Capacity Limit	0 to 100	100	%	LS_LIMIT
Enable Short Loop Gain	Enable/Dsable	Enable		SAGENABL

RESETCON (Temperature Reset and Demand Limit)

DESCRIPTION	VALUE	DEFAULT	UNITS	POINT NAME
COOLING RESET				
Cooling Reset Type	0 = No Reset 1 = 4-20 mA input 2 = External temp – OAT 3 = Return Fluid 4 = External temp - SPT	0		CRST_TYP
4-20 MA RESET				
4-20 – Degrees Reset	-30 to 30	0.0	ΔF	420_DEG
REMOTE RESET				
Remote – No Reset Temp	0 to 125	125.0	°F	REM_NO
Remote – Full Reset Temp	0 to 125	0.0	°F	REM_FULL
Remote – Degrees Reset	-30 to 30	0.0	ΔF	REM_DEG
RETURN TEMPERATURE RESET				
Return – No Reset Temp	0 to 125	10.0	ΔF	RTN_NO
Return – Full Reset Temp	0 to 125	0.0	ΔF	RTN_FULL
Return – Degrees Reset	-30 to 30	0.0	ΔF	RTN_DEG
DEMAND LIMIT				
Demand Limit Select	0 = None 1 = External switch input 2 = 4-20 mA input 3 = Loadshed	0		DMD_CTRL
Demand Limit at 20 mA	0 to 100	100	%	DMT20MA
Loadshed Group Number	0 to 99	0		SHED_NUM
Loadshed Demand Delta	0 to 60	0	%	SHED_DEL
Maximum Loadshed Time	0 to 120	60	minutes	SHED_TIM
Demand Limit Switch 1	0 to 100	80	%	DLSWSP1
Demand Limit Switch 2	0 to 100	50	%	DLSWSP2

SCHEDOVR (Timed Override Setup)

DESCRIPTION	VALUE	DEFAULT	UNITS	POINT NAME
Schedule Number	0 to 99	1		SCHEDNUM
Override Time Limit	0 to 4	0	hours	OTL
Timed Override Hours	0 to 4	0	hours	OVR_EXT
Timed Override	No/Yes	No		TIMEOVER

SETPOINT

DESCRIPTION	VALUE	DEFAULT	UNITS	POINT NAME
COOLING				
Cooling Setpoint 1	-20 to 70	44.0	°F	CSP1
Cooling Setpoint 2	-20 to 70	44.0	°F	CSP2
ICE Setpoint	-20 to 32	32.0	°F	CSP3
RAMP LOADING				
Cooling Ramp Loading	0.2 to 2.0	1.0		CRAMP
Brine Freeze Point	-20 to 34	34.0	°F	BRN_FRZ

UNIT

DESCRIPTION	VALUE	DEFAULT	UNITS	POINT NAME
Compressor A1 Size	8 to 15	60 Hz: 010-10; 015-15; 018-9; 022-9; 025-13; 030-15; 035-9; 040-13; 045-10; 050-13; 055-15 50 Hz: 010-11; 015-7; 018-9; 022-11; 025-13; 032-8; 035-13; 042-11; 045-13		SIZE_A1
Compressor A2 Size	0 to 15	60 Hz: 018-9; 022-13; 025-13; 030-15; 035-13; 040-13; 045-13; 050-13; 055-15 50 Hz: 015-7; 018-9; 022-11; 025-13; 032-11; 035-13; 042-11; 045-13		SIZE_A2
Compressor B1 Size	0 to 15	60 Hz: 035-15; 040-15; 045-10; 050-13; 055-15 50 Hz: 032-13; 035-13; 042-11; 045-13		SIZE_B1
Compressor B2 Size	0 to 15	60 Hz: 045-13; 050-13; 055-15 50 Hz: 042-11; 045-13		SIZE_B2
Suction Superheat Setpt	10 to 40	15		SH_SP
Refrigerant	1 = R22	1		REFRIG_T
Fan Staging Select	1 = 1 Fan 2 = 2 Fans 3 = 3 Fans 4 = 4 Fans	1 = One Fan (010-018) 2 = Two Fans (022-030) 3 = Three Fans (032-040) 4 = Four Fans (042-055)		FAN_TYPE

MAINTENANCE

ALARMS: Maintenance Display

DESCRIPTION	VALUE	POINT NAME
Active Alarm #1	Axxx or Txxx	ALARM01C
Active Alarm #2	Axxx or Txxx	ALARM02C
Active Alarm #3	Axxx or Txxx	ALARM03C
Active Alarm #4	Axxx or Txxx	ALARM04C
Active Alarm #5	Axxx or Txxx	ALARM05C
Active Alarm #6	Axxx or Txxx	ALARM06C
Active Alarm #7	Axxx or Txxx	ALARM07C
Active Alarm #8	Axxx or Txxx	ALARM08C
Active Alarm #9	Axxx or Txxx	ALARM09C
Active Alarm #10	Axxx or Txxx	ALARM10C
Active Alarm #11	Axxx or Txxx	ALARM11C
Active Alarm #12	Axxx or Txxx	ALARM12C
Active Alarm #13	Axxx or Txxx	ALARM13C
Active Alarm #14	Axxx or Txxx	ALARM14C
Active Alarm #15	Axxx or Txxx	ALARM15C
Active Alarm #16	Axxx or Txxx	ALARM16C
Active Alarm #17	Axxx or Txxx	ALARM17C
Active Alarm #18	Axxx or Txxx	ALARM18C
Active Alarm #19	Axxx or Txxx	ALARM19C
Active Alarm #20	Axxx or Txxx	ALARM20C
Active Alarm #21	Axxx or Txxx	ALARM21C
Active Alarm #22	Axxx or Txxx	ALARM22C
Active Alarm #23	Axxx or Txxx	ALARM23C
Active Alarm #24	Axxx or Txxx	ALARM24C
Active Alarm #25	Axxx or Txxx	ALARM25C

CURRMODS: Maintenance Display

DESCRIPTION	VALUE	POINT NAME
FSM controlling Chiller	On/Off	MODE_1
WSM controlling Chiller	On/Off	MODE_2
Master/Slave control	On/Off	MODE_3
Ramp Load Limited	On/Off	MODE_5
Timed Override in effect	On/Off	MODE_6
Low Cooler Suction TempA	On/Off	MODE_7
Low Cooler Suction TempB	On/Off	MODE_8
Slow Change Override	On/Off	MODE_9
Minimum OFF time active	On/Off	MODE_10
Dual Setpoint	On/Off	MODE_13
Temperature Reset	On/Off	MODE_14
Demand/Sound Limited	On/Off	MODE_15
Cooler Freeze Protection	On/Off	MODE_16
Low Temperature Cooling	On/Off	MODE_17
High Temperature Cooling	On/Off	MODE_18
Making ICE	On/Off	MODE_19
Storing ICE	On/Off	MODE_20
High SCT Circuit A	On/Off	MODE_21
High SCT Circuit B	On/Off	MODE_22
Minimum Comp. On Time	On/Off	MODE_23
Pump Off Delay Time	On/Off	MODE_24
Low Sound Mode	On/Off	MODE_25
Short Loop Override	On/Off	MODE_26

DUALCHIL: Maintenance Display

DESCRIPTION	VALUE	UNITS	POINT NAME
Dual Chiller Link Good?	Yes/No		DC_LINK
Master Chiller Role	Stand Alone, Lead Chiller, Lag Chiller		MC_ROLE
Slave Chiller Role	Stand Alone, Lead Chiller, Lag Chiller		SC_ROLE
Lead Chiller Ctrl Point	snnn.n	°F	LEAD_CP
Lag Chiller Ctrl Point	snnn.n	°F	LAG_CP
Control Point	snnn.n	°F	CTRL_PNT
Cool Entering Fluid-Slave	snnn.n	°F	COOLEWTS
Cool Leaving Fluid-Slave	snnn.n	°F	COOLLWTS
Cooler Entering Fluid	snnn.n	°F	COOL_EWT
Cooler Leaving Fluid	snnn.n	°F	COOL_LWT
Lead/Lag Leaving Fluid	snnn.n	°F	DUAL_LWT
Percent Avail.Capacity	0-100	%	CAP_A
Percent Avail.Cap.Slave	0-100	%	CAP_A_S
Lag Start Delay Time	hh:mm		LAGDELAY
Load/Unload Factor	snnn.n		SMZ
Load/Unload Factor-Slave	snnn.n		SMZSLAVE
Lead SMZ Clear Commanded	Yes/No		LEADSMZC
Lag- SMZ Clear Commanded	Yes/No		LAG_SMZC
Lag Commanded Off?	Yes/No		LAG_OFF
Dual Chill Lead CapLimit	0-100	%	DCLDCAPL
Dual Chill Lag CapLimit	0-100	%	DCLGCAPL

LEARNFNS: Maintenance Display

DESCRIPTION	VALUE	UNITS	POINT NAME
Fan 1 Delta SCT point 1	snnn.n	°F	F1DLTA1
Fan 1 Delta SCT point 2	snnn.n	°F	F1DLTA2
Fan 1 Delta SCT point 3	snnn.n	°F	F1DLTA3
Fan 1 Delta SCT point 4	snnn.n	°F	F1DLTA4
Fan 1 Delta SCT point 5	snnn.n	°F	F1DLTA5
Fan 2 Delta SCT point 1	snnn.n	°F	F2DLTA1
Fan 2 Delta SCT point 2	snnn.n	°F	F2DLTA2
Fan 2 Delta SCT point 3	snnn.n	°F	F2DLTA3
Fan 2 Delta SCT point 4	snnn.n	°F	F2DLTA4
Fan 2 Delta SCT point 5	snnn.n	°F	F2DLTA5
SCT Delta for Comp A1	snnn.n	°F	A1SCTDT
SCT Delta for Comp A2	snnn.n	°F	A2SCTDT
SCT Delta for Comp B1	snnn.n	°F	B1SCTDT
SCT Delta for Comp B2	snnn.n	°F	B2SCTDT
SAGP for Compressor A1	nn.n		SAGA1P
SAGM for Compressor A1	nn.n		SAGA1M
SAGP for Compressor A2	nn.n		SAGA2P
SAGM for Compressor A2	nn.n		SAGA2M
SAGP for Compressor B1	nn.n		SAGB1P
SAGM for Compressor B1	nn.n		SAGB1M
SAGP for Compressor B2	nn.n		SAGB2P
SAGM for Compressor B2	nn.n		SAGB2M

LOADFACT: Maintenance Display

DESCRIPTION	VALUE	UNITS	POINT NAME
CAPACITY CONTROL			
Load/Unload Factor	snnn.n		SMZ
Control Point	snnn.n	°F	CTRL_PNT
Entering Fluid Temp	snnn.n	°F	EWT
Leaving Fluid Temp	snnn.n	°F	LWT
Ramp Load Limited	On/Off		MODE_5
Slow Change Override	On/Off		MODE_9
Cooler Freeze Protection	On/Off		MODE_16
Low Temperature Cooling	On/Off		MODE_17
High Temperature Cooling	On/Off		MODE_18
Minimum Comp. On Time	On/Off		MODE_23

OCCUPANCY SUPERVISORY (OCCDEFM): Maintenance Display

DESCRIPTION	VALUE	POINT NAME
Current Mode (1=Occup.)	0/1	MODE
Current Occup. Period #	0-8	PER-NO
Timed-Override in Effect	Yes/No	OVERLAST
Time-Override Duration	0-4 hours	OVR_HRS
Current Occupied Time	hh:mm	STRTTIME
Current Unoccupied Time	hh:mm	ENDTIME
Next Occupied Day		NXTOCDAY
Next Occupied Time	hh:mm	NXTOCTIM
Next Unoccupied Day		NXTUNDAY
Next Unoccupied Time	hh:mm	NXTUNTIM
Previous Unoccupied Day		PRVUNDAY
Previous Unoccupied Time	hh:mm	PRVUNTIM

PM-COIL: Maintenance Display

DESCRIPTION	VALUE	UNITS	POINT NAME
Coil Cleaning Svc Inter	nnnnnn	hours	SI_COIL
Coil Service Countdown	nnnnnn	hours	CL_CDOWN
Coil Cleaning Maint.Done	Yes/No		CL_MAINT
Coil Cleaning Maint.Date	mm/dd/yy hh:mm		COIL_PM0
Coil Cleaning Maint.Date	mm/dd/yy hh:mm		COIL_PM1
Coil Cleaning Maint.Date	mm/dd/yy hh:mm		COIL_PM2
Coil Cleaning Maint.Date	mm/dd/yy hh:mm		COIL_PM3
Coil Cleaning Maint.Date	mm/dd/yy hh:mm		COIL_PM4

PM-PUMP: Maintenance Display

DESCRIPTION	VALUE	UNITS	POINT NAME
Pump Service Interval	nnnnnn	hours	SI_PUMPS
Pump 1 Service Countdown	nnnnnn	hours	P1_CDOWN
Pump 1 Maintenance Done	Yes/No		P1_MAINT
Pump 2 Service Countdown	nnnnnn	hours	P2_CDOWN
Pump 2 Maintenance Done	Yes/No		P2_MAINT
Pump 1 Maintenance Date	mm/dd/yy hh:mm		PMP1_PM0
Pump 1 Maintenance Date	mm/dd/yy hh:mm		PMP1_PM1
Pump 1 Maintenance Date	mm/dd/yy hh:mm		PMP1_PM2
Pump 1 Maintenance Date	mm/dd/yy hh:mm		PMP1_PM3
Pump 1 Maintenance Date	mm/dd/yy hh:mm		PMP1_PM4
Pump 2 Maintenance Date	mm/dd/yy hh:mm		PMP2_PM0
Pump 2 Maintenance Date	mm/dd/yy hh:mm		PMP2_PM1
Pump 2 Maintenance Date	mm/dd/yy hh:mm		PMP2_PM2
Pump 2 Maintenance Date	mm/dd/yy hh:mm		PMP2_PM3
Pump 2 Maintenance Date	mm/dd/yy hh:mm		PMP2_PM4

PM-STRN: Maintenance Display

DESCRIPTION	VALUE	UNITS	POINT NAME
Strainer Svc Interval	nnnnnn	hours	SI_STRNR
Strainer Svc Countdown	nnnnnn	hours	ST_CDOWN
Strainer Maint. Done	Yes/No		ST_MAINT
Strainer Maint. Date	mm/dd/yy hh:mm		STRN_PM0
Strainer Maint. Date	mm/dd/yy hh:mm		STRN_PM1
Strainer Maint. Date	mm/dd/yy hh:mm		STRN_PM2
Strainer Maint. Date	mm/dd/yy hh:mm		STRN_PM3
Strainer Maint. Date	mm/dd/yy hh:mm		STRN_PM4

RUNTEST: Maintenance Display

DESCRIPTION	VALUE	UNITS	POINT NAME
Percent Total Capacity	nnn	%	CAPA_T
Percent Available Cap.	nnn	%	CAPA_A
Discharge Pressure	nnn.n	psig	DP_A
Suction Pressure	nnn.n	psig	SP_A
Calculated HP Setpoint A	nnn.n	°F	HSP_A
Saturated Condensing Tmp	nnn.n	°F	TMP_SCTA
Saturated Suction Temp	nnn.n	°F	TMP_SSTA
Compr Return Gas Temp	nnn.n	°F	TMP_RGTA
Suction Superheat Temp	nnn.n	^F	SH_A
Compressor A1 Relay	On/Off		K_A1_RLY
Compressor A2 Relay	On/Off		K_A2_RLY
Minimum Load Valve Relay	On/Off		MLV_RLY
Compressor A1 Feedback	On/Off		K_A1_FBK
Compressor A2 Feedback	On/Off		K_A2_FBK
Percent Total Capacity	nnn	%	CAPB_T
Percent Available Cap.	nnn	%	CAPB_A
Discharge Pressure	nnn.n	psig	DP_B
Suction Pressure	nnn.n	psig	SP_B
Calculated HP Setpoint B	nnn.n	°F	HSP_B
Saturated Condensing Tmp	nnn.n	°F	TMP_SCTB
Saturated Suction Temp	nnn.n	°F	TMP_SSTB
Compr Return Gas Temp	nnn.n	°F	TMP_RGTB
Suction Superheat Temp	nnn.n	^F	SH_B
Compressor B1 Relay	On/Off		K_B1_RLY
Compressor B2 Relay	On/Off		K_B2_RLY
Minimum Load Valve Relay	On/Off		MLV_RLY
Compressor B1 Feedback	On/Off		K_B1_FBK
Compressor B2 Feedback	On/Off		K_B2_FBK
Fan 1 Relay	On/Off		FAN_1
Fan 2 Relay	On/Off		FAN_2
Outside Air Temperature	nnn.n	°F	OAT
Space Temperature	nnn.n	°F	SPT
Cooler Pump Relay 1	On/Off		COOLPMP1
Cooler Pump Relay 2	On/Off		COOLPMP2
Cooler Pump 1 Interlock	Open/Closed		PMP1_FBK
Cooler Pump 2 Interlock	Open/Closed		PMP2_FBK
Cooler Entering Fluid	nnn.n	°F	COOL_EWT
Cooler Leaving Fluid	nnn.n	°F	COOL_LWT
Compressor A1 Size	nnn	tons	SIZE_A1
Compressor A2 Size	nnn	tons	SIZE_A2
Compressor B1 Size	nnn	tons	SIZE_B1
Compressor B2 Size	nnn	tons	SIZE_B2
Cooler Flow Switch	On/Off		COOLFLOW

STRTHOUR: Maintenance Display

DESCRIPTION	VALUE	UNITS	POINT NAME
Machine Operating Hours	nnnnnn	hours	HR_MACH
Machine Starts	nnnnnn		CY_MACH
Circuit A Run Hours	nnnnnn	hours	HR_CIRA
Compressor A1 Run Hours	nnnnnn	hours	HR_A1
Compressor A2 Run Hours	nnnnnn	hours	HR_A2
Circuit B Run Hours	nnnnnn	hours	HR_CIRB
Compressor B1 Run Hours	nnnnnn	hours	HR_B1
Compressor B2 Run Hours	nnnnnn	hours	HR_B2
Circuit A Starts	nnnnnn		CY_CIRA
Compressor A1 Starts	nnnnnn		CY_A1
Compressor A2 Starts	nnnnnn		CY_A2
Circuit B Starts	nnnnnn		CY_CIRB
Compressor B1 Starts	nnnnnn		CY_B1
Compressor B2 Starts	nnnnnn		CY_B2
PUMP HOURS			
Pump 1 Run Hours	nnnnnn	hours	HR_PUMP1
Pump 2 Run Hours	nnnnnn	hours	HR_PUMP2

TESTMODE: Maintenance Display

DESCRIPTION	VALUE	UNITS	POINT NAME
Service Test Mode	On/Off		NET_CTRL
Compressor A1 Relay	On/Off		S_A1_RLY
Compressor A2 Relay	On/Off		S_A2_RLY
Compressor B1 Relay	On/Off		S_B1_RLY
Compressor B2 Relay	On/Off		S_B2_RLY
Fan 1 Relay	On/Off		S_FAN_1
Fan 2 Relay	On/Off		S_FAN_2
Cooler Pump Relay 1	On/Off		S_CLPMP1
Cooler Pump Relay 2	On/Off		S_CLPMP2
Minimum Load Valve Relay	On/Off		S_MLV
Remote Alarm Relay	On/Off		S_ALM

VERSIONS: Maintenance Display

DESCRIPTION	VERSION	VALUE
MBB	CESR131279-	nn-nn
EMM	CESR131174-	nn-nn
MARQUEE	CESR131171-	nn-nn
NAVIGATOR	CESR130227-	nn-nn

WSMDEFME: Maintenance Display

DESCRIPTION	VALUE	UNITS	POINT NAME
WSM Active?	Yes		WSMSTAT
Chilled water temp	snn.n	°F	CHWTEMP
Equipment status	On		CHLRST
Commanded state	Enable Dsable None		CHLRENA
CHW setpoint reset value	nn.n	^F	CHWRVAL
Current CHW setpoint	snn.n	°F	CHWSTPT

APPENDIX B
FACTORY SETTINGS FOR COMPRESSOR, FAN, PUMP,
AND MANUAL STARTERS

UNIT SIZE 30RA	VOLTAGE V-PH-Hz	VOLTAGE SERIES	OVERLOAD RELAY (CA1) SETTING FOR COMPRESSOR A1	OVERLOAD RELAY (CA2) SETTING FOR COMPRESSOR A2	MANUAL STARTER SETTING FOR FANS FC-HS/LS	MANUAL STARTER SETTING FOR FANS FC-A1/A2	MANUAL STARTER SETTING FOR CHC (Heaters)	MANUAL STARTER (CWP1, CWP2) SETTINGS FOR PUMP OPTIONS (Model Number Position 9)				
								A/F	B/G	C/H	D/J	E/K
010	575-3-60	-100	15.5	—	3.6	—	1.8	1.9	2.5	2.5	3.6	—
	380-3-60	-200	24.2	—	5.5	—	1.8	2.9	3.7	3.7	5.4	—
	230-3-60	-400	37.1	—	9.1	—	2.5	4.8	6.2	6.2	8.9	—
	208/230-3-60	-500	41.2	—	10.1	—	2.5	5.3	7.0	7.0	9.8	—
	460-3-60	-600	19.2	—	4.6	—	1.8	2.8	3.1	3.1	4.4	—
	230-3-50	-800	40.9	—	7.6	—	2.5	3.4	4.8	4.8	6.1	—
	380/415-3-50	-900	23.8	—	4.6	—	1.8	2.0	2.9	2.9	3.7	—
015	575-3-60	-100	22.7	—	3.6	—	1.8	1.9	2.5	2.5	3.6	—
	380-3-60	-200	36.1	—	5.5	—	1.8	2.9	3.7	3.7	5.4	—
	230-3-60	-400	52.6	—	9.1	—	2.5	4.8	6.2	6.2	8.9	—
	208/230-3-60	-500	58.4	—	10.1	—	2.5	5.3	7.0	7.0	9.8	—
	460-3-60	-600	28.6	—	4.6	—	1.8	2.8	3.1	3.1	4.4	—
	230-3-50	-800	31.1	31.1	7.6	—	2.5	3.4	4.8	4.8	6.1	—
	380/415-3-50	-900	17.2	17.2	4.6	—	1.8	2.0	2.9	2.9	3.7	—
018	575-3-60	-100	13.6	13.6	3.6	—	1.8	1.9	2.5	2.5	3.6	—
	380-3-60	-200	21	21	5.5	—	1.8	2.9	3.7	3.7	5.4	—
	230-3-60	-400	31.9	31.9	9.1	—	2.5	4.8	6.2	6.2	8.9	—
	208/230-3-60	-500	35.4	35.4	10.1	—	2.5	5.3	7.0	7.0	9.8	—
	460-3-60	-600	16.9	16.9	4.6	—	1.8	2.8	3.1	3.1	4.4	—
	230-3-50	-800	33.7	33.7	7.6	—	2.5	3.4	4.8	4.8	6.1	—
	380/415-3-50	-900	18.7	18.7	4.6	—	1.8	2.0	2.9	2.9	3.7	—
022	575-3-60	-100	14.6	19.9	—	2.3	1.8	1.9	2.5	2.5	3.6	—
	380-3-60	-200	22.7	31.7	—	3.5	1.8	2.9	3.7	3.7	5.4	—
	230-3-60	-400	35.3	44	—	5.8	2.5	4.8	6.2	6.2	8.9	—
	208/230-3-60	-500	39.2	49	—	7.0	2.5	5.3	7.0	7.0	9.8	—
	460-3-60	-600	17.5	24.2	—	2.9	1.8	2.8	3.1	3.1	4.4	—
	230-3-50	-800	40.9	40.9	—	4.6	2.5	3.4	4.8	4.8	6.1	—
	380/415-3-50	-900	23.8	23.8	—	3.7	1.8	2.0	2.9	2.9	3.7	—
025	575-3-60	-100	19.9	19.9	—	2.3	1.8	1.9	2.5	2.5	3.6	—
	380-3-60	-200	31.7	31.7	—	3.5	1.8	2.9	3.7	3.7	5.4	—
	230-3-60	-400	44	44	—	5.8	2.5	4.8	6.2	6.2	8.9	—
	208/230-3-60	-500	49	49	—	7.0	2.5	5.3	7.0	7.0	9.8	—
	460-3-60	-600	24.2	24.2	—	2.9	1.8	2.8	3.1	3.1	4.4	—
	230-3-50	-800	49.9	49.9	—	4.6	2.5	3.4	4.8	4.8	6.1	—
	380/415-3-50	-900	29	29	—	3.7	1.8	2.0	2.9	2.9	3.7	—
030	575-3-60	-100	22.7	22.7	—	2.3	1.8	1.9	2.5	2.5	3.6	—
	380-3-60	-200	36.1	36.1	—	3.5	1.8	2.9	3.7	3.7	5.4	—
	230-3-60	-400	52.6	52.6	—	5.8	2.5	4.8	6.2	6.2	8.9	—
	208/230-3-60	-500	58.4	58.4	—	7.0	2.5	5.3	7.0	7.0	9.8	—
	460-3-60	-600	28.6	28.6	—	2.9	1.8	2.8	3.1	3.1	4.4	—

**FACTORY SETTINGS FOR COMPRESSOR, FAN, PUMP,
AND MANUAL STARTERS (cont)**

UNIT SIZE 30RA	VOLTAGE V-PH-Hz	VOLTAGE SERIES	OVERLOAD RELAY (CA1) SETTING FOR COMPRESSOR A1	OVERLOAD RELAY (CA2) SETTING FOR COMPRESSOR A2	OVERLOAD RELAY (CB1) SETTING FOR COMPRESSOR B1	OVERLOAD RELAY (CB2) SETTING FOR COMPRESSOR B2	MANUAL STARTER FOR FANS FC-HS/LS	MANUAL STARTER SETTING FOR FC-A1/A2	MANUAL STARTER SETTING FOR CHC (Heaters)	MANUAL STARTER SETTINGS FOR PUMP OPTIONS (Model Number Position 9)				
										A/F	B/G	C/H	D/J	E/K
032	230-3-50	-800	31.4	40.9	49.9	—	7.6	4.6	2.5	—	4.8	—	6.1	10.4
	380/415-3-50	-900	17.4	23.8	29	—	4.6	3.7	1.8	—	2.9	—	3.7	6.4
035	575-3-60	-100	14.6	19.9	22.7	—	3.6	2.3	1.8	—	2.5	—	3.6	6.0
	380-3-60	-200	22.7	31.7	36.1	—	5.5	3.5	1.8	—	3.7	—	5.4	9.1
	230-3-60	-400	35.3	44	52.6	—	9.1	5.8	2.5	—	6.2	—	8.9	15.1
	208/230-3-60	-500	39.2	49	58.4	—	10.1	7.0	2.5	—	7.0	—	9.8	16.7
	460-3-60	-600	17.5	24.2	28.6	—	4.6	2.9	1.8	—	3.1	—	4.4	7.6
	230-3-50	-800	49.9	49.9	49.9	—	7.6	4.6	2.5	—	4.8	—	6.1	10.4
	380/415-3-50	-900	29	29	29	—	4.6	3.7	1.8	—	2.9	—	3.7	6.4
040	575-3-60	-100	19.9	19.9	22.7	—	3.6	2.3	1.8	—	2.5	—	3.6	6.0
	380-3-60	-200	31.7	31.7	36.1	—	5.5	3.5	1.8	—	3.7	—	5.4	9.1
	230-3-60	-400	44	44	52.6	—	9.1	5.8	2.5	—	6.2	—	8.9	15.1
	208/230-3-60	-500	49	49	58.4	—	10.1	7.0	2.5	—	7.0	—	9.8	16.7
	460-3-60	-600	24.2	24.2	28.6	—	4.6	2.9	1.8	—	3.1	—	4.4	7.6
042	230-3-50	-800	40.9	40.9	40.9	40.9	—	4.6	2.5	—	4.8	—	6.1	10.4
	380/415-3-50	-900	23.8	23.8	23.8	23.8	—	3.7	1.8	—	2.9	—	3.7	6.4
045	575-3-60	-100	15.5	19.9	15.5	19.9	—	2.3	1.8	—	2.5	—	3.6	6.0
	380-3-60	-200	24.2	31.7	24.2	31.7	—	3.5	1.8	—	3.7	—	5.4	9.1
	230-3-60	-400	37.1	44	37.1	44	—	5.8	2.5	—	6.2	—	8.9	15.1
	208/230-3-60	-500	41.2	49	41.2	49	—	7.0	2.5	—	7.0	—	9.8	16.7
	460-3-60	-600	19.2	24.2	19.2	24.2	—	2.9	1.8	—	3.1	—	4.4	7.6
	230-3-50	-800	49.9	49.9	49.9	49.9	—	4.6	2.5	—	4.8	—	6.1	10.4
	380/415-3-50	-900	29	29	29	29	—	3.7	1.8	—	2.9	—	3.7	6.4
050	575-3-60	-100	19.9	19.9	19.9	19.9	—	2.3	1.8	—	2.5	—	3.6	6.0
	380-3-60	-200	31.7	31.7	31.7	31.7	—	3.5	1.8	—	3.7	—	5.4	9.1
	230-3-60	-400	44	44	44	44	—	5.8	2.5	—	6.2	—	8.9	15.1
	208/230-3-60	-500	49	49	49	49	—	7.0	2.5	—	7.0	—	9.8	16.7
	460-3-60	-600	24.2	24.2	24.2	24.2	—	2.9	1.8	—	3.1	—	4.4	7.6
055	575-3-60	-100	22.7	22.7	22.7	22.7	—	2.3	1.8	—	2.5	—	3.6	6.0
	380-3-60	-200	36.1	36.1	36.1	36.1	—	3.5	1.8	—	3.7	—	5.4	9.1
	230-3-60	-400	52.6	52.6	52.6	52.6	—	5.8	2.5	—	6.2	—	8.9	15.1
	208/230-3-60	-500	58.4	58.4	58.4	58.4	—	7.0	2.5	—	7.0	—	9.8	16.7
	460-3-60	-600	28.6	28.6	28.6	28.6	—	2.9	1.8	—	3.1	—	4.4	7.6

APPENDIX C

Building Interface — The 30RAN chiller can be interfaced with multi-vendor control systems through 3 levels of inter-operability using BAClink, DataPort™, or DataLink™ controls. BAClink controls function as a gateway between a CCN and a BACnet™ system to facilitate the passing of data from the CCN to BACnet. The Carrier DataPort control is an interface device that allows other HVAC control systems to “read only” values in system elements connected to a CCN

communication bus. The Carrier DataLink control is an interface device that allows other HVAC control systems to read and change (“read/write”) values in system elements connected to a CCN bus. Both DataPort and DataLink controls request data from a specified CCN system element and translate this data into ASCII characters off network. Information from the 30RAN chiller control to support interface are listed in the following tables.

DataPort, DataLink, BAClink Object Definition

CCN TABLE NAME	DESCRIPTION	STATUS	UNITS	POINT	DataPort	DataLink	BAClink	
A_UNIT	GENERAL PARAMETERS							
	Control Mode	(Modes 0-9)		STAT	RO	RO	RO	
	Occupied	No/Yes		OCC	RO	RO	RO	
	CCN Chiller	Start/Stop		CHIL_S_S	RO	RW	RW	
	Low Sound Active	No/Yes		LSACTIVE	RO	RO	NA	
	Alarm State	Normal/Alert/Alarm		ALM	RO	RO	RO	
	Active Demand Limit	0 to 100	%	DEM_LIM	RO	RW	RW	
	Override Modes In Effect	No/Yes		MODE	RO	RO	NA	
	Percent Total Capacity	0 to 100	%	CAP_T	RO	RO	RO	
	Requested Stage	0 to 99		STAGE	RO	RO	NA	
	Active Setpoint	-20 to 70 (-28.8 to 21.1)	°F (°C)	SP	RO	RO	NA	
	Control Point	-20 to 70 (-28.8 to 21.1)	°F (°C)	CTRL_PNT	RO	RW	RW	
	Entering Fluid Temp	snnn.n	°F (°C)	EWT	RO	RO	RO	
	Leaving Fluid Temp	snnn.n	°F (°C)	LWT	RO	RO	RO	
	Emergency Stop	Enable/Emstop		EMSTOP	RO	RW	RW	
	Minutes Left for Start	00:00 to 15:00	Minutes	MIN_LEFT	RO	RO	NA	
	PUMPS							
	Cooler Pump Relay 1	Off/On		COOLPMP1	RO	RO	NA	
	Cooler Pump Relay 2	Off/On		COOLPMP2	RO	RO	NA	
	Cooler Pump 1 Interlock	Open/Close		PMP1_FBK	RO	RO	NA	
	Cooler Pump 2 Interlock	Open/Close		PMP2_FBK	RO	RO	NA	
	Cooler Flow Switch	Off/On		COOLFLOW	RO	RO	NA	
	Lead Pump	0, 1, 2		LEADPUMP	RO	RO	NA	
	Rotate Cooler Pumps Now	No/Yes		ROT_PUMP	RO	RO	NA	
	Heat/Cool Select	Heat/Cool		HC_SEL	RO	RO	NA	
	CIRCADIO	CIRC. A DISCRETE OUTPUTS						
		Compressor A1 Relay	Off/On		K_A1_RLY	RO	RO	RO
Compressor A2 Relay		Off/On		K_A2_RLY	RO	RO	RO	
Minimum Load Valve Relay		Off/On		MLV_RLY	RO	RO	NA	
CIRC. A DISCRETE INPUTS								
Compressor A1 Feedback	Off/On		K_A1_FBK	RO	RO	NA		
Compressor A2 Feedback	Off/On		K_A2_FBK	RO	RO	NA		
CIRCA_AN	CIRCUIT A ANALOG VALUES							
	Percent Total Capacity	0 to 100	%	CAPA_T	RO	RO	RO	
	Percent Available Cap.	0 to 100	%	CAPA_A	RO	RO	RO	
	Discharge Pressure	nnn.n	PSIG (KPA)	DP_A	RO	RO	RO	
	Suction Pressure	nnn.n	PSIG (KPA)	SP_A	RO	RO	RO	
	Calculated HP Setpoint A	nnn.n	°F (°C)	HSP_A	RO	RO	NA	
	Saturated Condensing Temp	snnn.n	°F (°C)	TMP_SCTA	RO	RO	RO	
	Saturated Suction Temp	snnn.n	°F (°C)	TMP_SSTA	RO	RO	RO	
	Compr Return Gas Temp	snnn.n	°F (°C)	TMP_RGTA	RO	RO	NA	
Suction Superheat Temp	snnn.n	dF (dC)	SH_A	RO	RO	RO		
CIRCBDIO	CIRC. B DISCRETE OUTPUTS							
	Compressor B1 Relay	Off/On		K_B1_RLY	RO	RO	RO	
	Compressor B2 Relay	Off/On		K_B2_RLY	RO	RO	RO	
	Minimum Load Valve Relay	Off/On		MLV_RLY	RO	RO	NA	
	CIRC. B DISCRETE INPUTS							
Compressor B1 Feedback	Off/On		K_B1_FBK	RO	RO	NA		
Compressor B2 Feedback	Off/On		K_B2_FBK	RO	RO	NA		
CIRCB_AN	CIRCUIT B ANALOG VALUES							
	Percent Total Capacity	0 to 100	%	CAPB_T	RO	RO	RO	
	Percent Available Cap.	0 to 100	%	CAPB_A	RO	RO	RO	
	Discharge Pressure	nnn.n	PSIG (KPA)	DP_B	RO	RO	RO	
	Suction Pressure	nnn.n	PSIG (KPA)	SP_B	RO	RO	RO	
	Calculated HP Setpoint B	nnn.n	°F (°C)	HSP_B	RO	RO	NA	
	Saturated Condensing Temp	snnn.n	°F (°C)	TMP_SCTB	RO	RO	RO	
	Saturated Suction Temp	snnn.n	°F (°C)	TMP_SSTB	RO	RO	RO	
	Compr Return Gas Temp	snnn.n	°F (°C)	TMP_RGTB	RO	RO	NA	
Suction Superheat Temp	snnn.n	dF (dC)	SH_B	RO	RO	RO		

LEGEND

NA — Not Available
 RO — Read Only
 RW — Read/Write

NOTE: In order to write to any point with DataLink or BAClink controls, the machine must be configured for CCN control. CTRL Control Method (Configuration mode, sub-mode OPT2) must be set to 3 = CCN Control.

DataPort, DataLink, BAclink Object Definition (cont)

CCN TABLE NAME	DESCRIPTION	STATUS	UNITS	POINT	DataPort	DataLink	BAClink
OPTIONS	FANS						
	Fan 1 Relay	Off/On		FAN_1	RO	RO	RO
	Fan 2 Relay	Off/On		FAN_2	RO	RO	RO
	Cooler/Pump Heater	Off/On		COOL_HTR	RO	RO	NA
	UNIT ANALOG VALUES						
	Cooler Entering Fluid	snnn.n	°F (°C)	COOL_EWT	RO	RO	RO
	Cooler Leaving Fluid	snnn.n	°F (°C)	COOL_LWT	RO	RO	RO
	Lead/Lag Fluid	snnn.n	°F (°C)	DUAL_LWT	RO	RO	NA
	TEMPERTURE RESET						
	4-20 mA Reset Signal	nn.n	ma	RST_MA	RO	RO	RO
	Outside Air Temperature	snnn.n	°F (°C)	OAT	RO	RW	NA
	Space Temperature	snnn.n	°F (°C)	SPT	RO	RW	NA
	DEMAND LIMIT						
	4-20 mA Demand Signal	nn.n	ma	LMT_MA	RO	RO	RO
	Demand Limit Switch 1	Off/On		DMD_SW1	RO	RO	NA
	Demand Limit Switch 2	Off/On		DMD_SW2	RO	RO	NA
	CCN Loadshed Signal	0, 1, 2		DL_STAT	RO	RO	RO
	MISCELLANEOUS						
Heat Request	Off/On		HEAT_REQ	RO	RO	NA	
Dual Setpoint Switch	Off/On		DUAL_IN	RO	RO	NA	
Cooler LWT Setpoint	snnn.n	°F (°C)	LWT_SP	RO	RO	NA	
Ice Done	Off/On		ICE_DONE	RO	RO	NA	
SETPOINT	COOLING						
	Cooling Setpoint 1	-20 to 70 (-28.8 to 21.1)	°F (°C)	CSP1	NA	RW	RW
	Cooling Setpoint 2	-20 to 70 (-28.8 to 21.1)	°F (°C)	CSP2	NA	RW	NA
	Ice Setpoint	-20 to 32 (-28.8 to 0.0)	°F (°C)	CSP3	NA	RW	NA
	RAMP LOADING						
Cooling Ramp Loading	0.2 to 2.0 (0.1 to 1.1)	dF (dC)	CRAMP	NA	RW	NA	
Brine Freeze Point	-20 to 34 (-28.8 to 1.1)	°F (°C)	BRN_FRZ	NA	RW	NA	
OCCPC01S	Timed Override Hours	0	Hours	OVR-EXT	NA	RW	RW
	Period 1 DOW (MTWTFSSH)	00000000		DOW1	NA	RW	RW
	Occupied Time	00:00		OCCTOD1	NA	RW	RW
	Unoccupied Time	00:00		UNOCTOD1	NA	RW	RW
	Period 2 DOW (MTWTFSSH)	00000000		DOW2	NA	RW	RW
	Occupied Time	00:00		OCCTOD2	NA	RW	RW
	Unoccupied Time	00:00		UNOCTOD2	NA	RW	RW
	Period 3 DOW (MTWTFSSH)	00000000		DOW3	NA	RW	RW
	Occupied Time	00:00		OCCTOD3	NA	RW	RW
	Unoccupied Time	00:00		UNOCTOD3	NA	RW	RW
	Period 4 DOW (MTWTFSSH)	00000000		DOW4	NA	RW	RW
	Occupied Time	00:00		OCCTOD4	NA	RW	RW
	Unoccupied Time	00:00		UNOCTOD4	NA	RW	RW
	Period 5 DOW (MTWTFSSH)	00000000		DOW5	NA	RW	RW
	Occupied Time	00:00		OCCTOD5	NA	RW	RW
	Unoccupied Time	00:00		UNOCTOD5	NA	RW	RW
	Period 6 DOW (MTWTFSSH)	00000000		DOW6	NA	RW	RW
	Occupied Time	00:00		OCCTOD6	NA	RW	RW
	Unoccupied Time	00:00		UNOCTOD6	NA	RW	RW
	Period 7 DOW (MTWTFSSH)	00000000		DOW7	NA	RW	RW
Occupied Time	00:00		OCCTOD7	NA	RW	RW	
Unoccupied Time	00:00		UNOCTOD7	NA	RW	RW	
Period 8 DOW (MTWTFSSH)	00000000		DOW8	NA	RW	RW	
Occupied Time	00:00		OCCTOD8	NA	RW	RW	
Unoccupied Time	00:00		UNOCTOD8	NA	RW	RW	

LEGEND

NA — Not Available
RO — Read Only
RW — Read/Write

NOTE: In order to write to any point with DataLink or BAClink controls, the machine must be configured for CCN control. CTRL Control Method (Configuration mode, sub-mode OPT2) must be set to 3 = CCN Control.

START-UP CHECKLIST FOR 30RA LIQUID CHILLER
(Remove and use for Job File)

I. Project Information

JOB NAME _____

ADDRESS _____

CITY _____ STATE _____ ZIP _____

INSTALLING CONTRACTOR _____

SALES OFFICE _____

START-UP PERFORMED BY _____

Design Information

CAPACITY	CEAT	EWT	LWT	FLUID TYPE	FLOW RATE	P.D.

UNIT MODEL _____ SERIAL _____

II. Preliminary Equipment Check

IS THERE ANY PHYSICAL DAMAGE? YES NO

DESCRIPTION _____

- 1. UNIT IS INSTALLED LEVEL AS PER THE INSTALLATION INSTRUCTIONS. YES NO
- 2. POWER SUPPLY AGREES WITH THE UNIT NAMEPLATE. YES NO
- 3. ELECTRICAL POWER WIRING IS INSTALLED PROPERLY. YES NO
- 4. UNIT IS PROPERLY GROUNDED. YES NO
- 5. ELECTRICAL CIRCUIT PROTECTION HAS BEEN SIZED AND INSTALLED PROPERLY. YES NO
- 6. ALL TERMINALS ARE TIGHT. YES NO
- 7. ALL PLUG ASSEMBLIES ARE TIGHT. YES NO
- 8. ALL CABLES AND THERMISTORS HAVE BEEN INSPECTED FOR CROSSED WIRES. YES NO
- 9. ALL THERMISTORS ARE FULLY INSERTED INTO WELLS. YES NO

Chilled Water System Check

- 1. ALL CHILLED WATER VALVES ARE OPEN. YES NO
- 2. ALL PIPING IS CONNECTED PROPERLY. YES NO
- 3. ALL AIR HAS BEEN PURGED FROM THE SYSTEM. YES NO
- 4. CHILLED WATER PUMP IS OPERATING WITH THE CORRECT ROTATION. YES NO

OPERATING DATA:

RECORD THE FOLLOWING INFORMATION FROM THE PRESSURES AND TEMPERATURES MODES WHEN MACHINE IS IN A STABLE OPERATING CONDITION:

PRESSURE/TEMPERATURE

	CIRCUIT A	CIRCUIT B
DISCHARGE PRESSURE	DP.A	DP.B
SUCTION PRESSURE	SP.A	SP.B
SATURATED CONDENSING TEMP	SCT.A	SCT.B
SATURATED SUCTION TEMP	SST.A	SST.B
LIQUID LINE TEMPERATURE*		
DISCHARGE LINE TEMPERATURE*		
RETURN GAS TEMPERATURE*		

*Readings taken with a digital thermometer.

COOLER EWT	EWT	
COOLER LWT	LWT	
OUTDOOR-AIR TEMPERATURE	OAT	
CONTROL POINT	CTPT	
PERCENT TOTAL CAPACITY	CAP	
LEAD/LAG LEAVING FLUID	DLWT	(Dual Chiller Control Only)

Compressor Running Current — All readings taken at full load.

COMPRESSOR MOTOR CURRENT	L1	L2	L3
COMPRESSOR A1			
COMPRESSOR A2			
COMPRESSOR B1			
COMPRESSOR B2			

CONDENSER FAN MOTOR CURRENT	L1	L2	L3
FAN MOTOR 1			
FAN MOTOR 2			
FAN MOTOR 3			
FAN MOTOR 4			

COOLER PUMP MOTOR CURRENT	L1	L2	L3
COOLER PUMP 1			
COOLER PUMP 2			

III. Unit Start-Up (cont)

RECORD CONFIGURATION SETTINGS

UNIT (Configuration Settings)

SUBMODE	ITEM	DISPLAY	DESCRIPTION	VALUE
UNIT			UNIT CONFIGURATION	
	SZA.1	XX	COMPRESSOR A1 SIZE	
	SZA.2	XX	COMPRESSOR A2 SIZE	
	SZB.1	XX	COMPRESSOR B1 SIZE	
	SZB.2	XX	COMPRESSOR B2 SIZE	
	SH.SP	XX.X ΔF	SUPERHEAT SETPOINT	
	REFG	X	REFRIGERANT	
	FAN.S	X	FAN STAGING SELECT	

PRESS ESCAPE KEY TO DISPLAY 'UNIT'. PRESS DOWN ARROW KEY TO DISPLAY 'OPT1'.
PRESS ENTER KEY. RECORD CONFIGURATION INFORMATION BELOW:

OPTIONS1 (Options Configuration)

SUBMODE	ITEM	DISPLAY	DESCRIPTION	VALUE
OPT1			UNIT OPTIONS 1 HARDWARE	
	FLUD	X	COOLER FLUID	
	MLV.S	YES/NO	MINIMUM LOAD VALVE SELECT	
	MMR.S	YES/NO	MOTORMASTER SELECT	
	RG.EN	ENBL/DSBL	RETURN GAS SENSOR ENABLE	
	CPC	ON/OFF	COOLER PUMP CONTROL	
	PM1E	YES/NO	COOLER PUMP 1 ENABLE	
	PM2E	YES/NO	COOLER PUMP 2 ENABLE	
	PM.PS	YES/NO	COOLER PMP PERIODIC STRT	
	PM.SL	X	COOLER PUMP SELECT	
	PM.DY	XX MIN	COOLER PUMP SHUTDOWN DLY	
	PM.DT	XXXX HRS	PUMP CHANGEOVER HOURS	
	ROT.P	YES/NO	ROTATE COOLER PUMPS NOW	
	EMM	YES/NO	EMM MODULE INSTALLED	

III. Unit Start-Up (cont)

PRESS ESCAPE KEY TO DISPLAY 'OPT1'. PRESS DOWN ARROW KEY TO DISPLAY 'OPT2'.
PRESS ENTER KEY.

RECORD CONFIGURATION INFORMATION BELOW.

OPTIONS2 (Options Configuration)

SUBMODE	ITEM	DISPLAY	DESCRIPTION	VALUE
OPT2			UNIT OPTIONS 2 CONTROLS	
	CTRL	X	CONTROL METHOD	
	CCNA	XXX	CCN ADDRESS	
	CCNB	XXX	CCN BUS NUMBER	
	BAUD	X	CCN BAUD RATE	
	LOAD	X	LOADING SEQUENCE SELECT	
	LLCS	X	LEAD/LAG CIRCUIT SELECT	
	LCWT	XX.X ΔF	HIGH LCW ALERT LIMIT	
	DELY	XX	MINUTES OFF TIME	
	ICE.M	ENBL/DSBL	ICE MODE ENABLE	
	CLS.C	ENBL/DSBL	CLOSE CONTROL SELECT	
	LS.MD	X	LOW SOUND MODE SELECT	
	LS.ST	00:00	LOW SOUND START TIME	
	LS.ND	00:00	LOW SOUND END TIME	
LS.LT	XXX %	LOW SOUND CAPACITY LIMIT		

RSET (Reset Configuration Settings)

SUBMODE	ITEM	DISPLAY	DESCRIPTION	VALUE
RSET			RESET COOL TEMP	
	CRST	X	COOLING RESET TYPE	
	MA.DG	XX.X °F	4-20 - DEGREES RESET	
	RM.NO	XXX.X °F	REMOTE - NO RESET TEMP	
	RM.F	XXX.X °F	REMOTE - FULL RESET TEMP	
	RM.DG	XX.X °F	REMOTE - DEGREES RESET	
	RT.NO	XXX.X °F	RETURN - NO RESET TEMP	
	RT.F	XXX.X °F	RETURN - FULL RESET TEMP	
	RT.DG	XX.X °F	RETURN - DEGREES RESET	
	DMDC	X	DEMAND LIMIT SELECT	
	DM20	XXX %	DEMAND LIMIT AT 20 MA	
	SHNM	XXX	LOADSHED GROUP NUMBER	
	SHDL	XXX %	LOADSHED DEMAND DELTA	
	SHTM	XXX	MAXIMUM LOADSHED TIME	
	DLS1	XXX %	DEMAND LIMIT SWITCH 1	
	DLS2	XXX %	DEMAND LIMIT SWITCH 2	
	LLEN	ENBL/DSBL	LEAD/LAG CHILLER ENABLE	
	MSSL	SLVE/MAST	MASTER/SLAVE SELECT	
	SLVA	XXX	SLAVE ADDRESS	
	LLBL	X	LEAD/LAG BALANCE SELECT	
	LLBD	XXX	LEAD/LAG BALANCE DELTA	
	LLDY	XXX	LAG START DELAY	
	PARA	YES/NO	PARALLEL CONFIGURATION	

III. Unit Start-Up (cont)

PRESS ESCAPE KEY TO DISPLAY 'RSET'. PRESS DOWN ARROW KEY TO DISPLAY 'SLCT'.
PRESS ENTER KEY.

RECORD CONFIGURATION INFORMATION BELOW:

SLCT (Setpoint and Ramp Load Configuration)

SUBMODE	ITEM	DISPLAY	DESCRIPTION	VALUE
SLCT			SETPOINT AND RAMP LOAD	
	CLSP	X	COOLING SETPOINT SELECT	
	RL.S	ENBL/DSBL	RAMP LOAD SELECT	
	CRMP	X.X	COOLING RAMP LOADING	
	SCHD	XX	SCHEDULE NUMBER	
	Z.GN	X.X	DEADBAND MULTIPLIER	

PRESS ESCAPE KEY SEVERAL TIMES TO GET TO THE MODE LEVEL (BLANK DISPLAY). USE THE
ARROW KEYS TO SCROLL TO THE SET POINT LED. PRESS ENTER TO DISPLAY SETPOINTS.
RECORD CONFIGURATION INFORMATION BELOW:

SETPOINT

SUBMODE	ITEM	DISPLAY	DESCRIPTION	VALUE
COOL			COOLING SETPOINTS	
	CSP.1	XXX.X °F	COOLING SETPOINT 1	
	CSP.2	XXX.X °F	COOLING SETPOINT 2	
	CSP.3	XXX.X °F	ICE SETPOINT	
HEAD			HEAD PRESSURE SETPOINTS	
	HD.PA	XXX.X °F	CALCULATED HP SETPOINT A	
	HD.PB	XXX.X °F	CALCULATED HP SETPOINT B	
FRZ			BRINE FREEZE SETPOINT	
	BR.FZ	XXX.X °F	BRINE FREEZE POINT	

III. Unit Start-Up (cont)

COMPONENT TEST

USE ESCAPE/ARROW KEYS TO ILLUMINATE CONFIGURATION LED. PRESS ENTER TO DISPLAY 'DISP'. PRESS ENTER AGAIN TO DISPLAY 'TEST' FOLLOWED BY 'OFF'. PRESS ENTER TO STOP DISPLAY AT 'OFF' AND ENTER AGAIN SO 'OFF' DISPLAY FLASHES. 'PASS' AND 'WORD' WILL FLASH IF PASSWORD NEEDS TO BE ENTERED. PRESS ENTER TO DISPLAY PASSWORD FIELD AND USE THE ENTER KEY FOR EACH OF THE FOUR PASSWORD DIGITS. USE ARROW KEYS IF PASSWORD IS OTHER THAN STANDARD. AT FLASHING 'OFF' DISPLAY, PRESS THE UP ARROW KEY TO DISPLAY 'ON' AND PRESS ENTER. ALL LED SEGMENTS AND MODE LEDS WILL LIGHT UP. PRESS ESCAPE TO STOP THE TEST. PRESS ESCAPE TO RETURN TO THE 'DISP' DISPLAY. PRESS THE ESCAPE KEY AGAIN AND USE THE ARROW KEYS TO ILLUMINATE THE SERVICE TEST LED. PRESS ENTER TO DISPLAY 'TEST'. PRESS ENTER TO STOP DISPLAY AT 'OFF' AND ENTER AGAIN SO 'OFF' FLASHES. PRESS THE UP ARROW KEY AND ENTER TO ENABLE THE MANUAL MODE. PRESS ESCAPE AND DISPLAY NOW SAYS 'TEST' 'ON'. REFER TO THE TABLE BELOW.

Service Test Mode and Sub-Mode Directory

SUB-MODE	KEYPAD ENTRY	ITEM	DISPLAY	ITEM EXPANSION	COMMENT	Completed (Yes/No)
TEST	ENTER		ON/OFF	SERVICE TEST MODE	To Enable Service Test Mode, move Enable/Off/Remote Contact switch to OFF. Change TEST to ON. Move switch to ENABLE.	
		OUTPUTS AND PUMPS				
OUTS	ENTER	FAN1	ON/OFF	FAN 1 RELAY	SIZES 010-018, Condenser fan at low speed SIZES 022-030 Condenser fan A1 energized SIZES 032-055, Condenser fan A2 energized	
	↓	FAN2	ON/OFF	FAN 2 RELAY	SIZES 022-030, Condenser fan A2 energized SIZES 032-040, Condenser fan B1 at high speed SIZES 042-055, Condenser fan B2 energized	
	↓	CLP.1	ON/OFF	COOLER PUMP 1 RELAY		
	↓	CLP.2	ON/OFF	COOLER PUMP 2 RELAY		
	↓	CL.HT	ON/OFF	COOLER/PUMP HEATER		
	↓	RMT.A	ON/OFF	REMOTE ALARM RELAY		
	CIRCUIT A COMPRESSOR TEST					
CMPA	ENTER	CC.A1	ON/OFF	COMPRESSOR A1 RELAY		
	↓	CC.A2	ON/OFF	COMPRESSOR A2 RELAY		
	↓	MLV	ON/OFF	MINIMUM LOAD VALVE RELAY		
CIRCUIT B COMPRESSOR TEST						
CMPB	ENTER	CC.B1	ON/OFF	COMPRESSOR B1 RELAY	See Note	
	↓	CC.B2	ON/OFF	COMPRESSOR B2 RELAY	See Note	
	↓	MLV	ON/OFF	MINIMUM LOAD VALVE RELAY	See Note	

NOTE: If the unit has a single circuit, the Circuit B items will not appear in the display, except the ability to configure circuit B will be displayed.

CUT ALONG DOTTED LINE