



Service Manual

TABLE OF CONTENTS

	PAGE
SAFETY CONSIDERATIONS	1
STANDARD FEATURES AND ACCESSORIES	2
SPECIFICATIONS - COOLING ONLY	3
SPECIFICATIONS - HEAT PUMP UNITS	4
DIMENSIONS	5
SERVICE VALVE LOCATIONS	5
CLEARANCES	6
SYSTEM OPERATING ENVELOPE	7
ELECTRICAL DATA	7
WIRING	8
CONNECTION DIAGRAMS	9
WIRING DIAGRAMS	10 - 16
REFRIGERATION CYCLE DIAGRAM	17
REFRIGERANT LINES	18
SYSTEM EVACUATION AND CHARGING	19
CONTROL SYSTEM	20
SYSTEM SAFETIES	20
3 MINUTE TIME DELAY	20
COMPRESSOR OVERCURRENT PROTECTION	20 - 21
SEQUENCE OF OPERATION	21
MODES OF OPERATION	22 - 24
TROUBLESHOOTING	25 - 37
APPENDIX	38 - 43

SAFETY CONSIDERATIONS

Improper installation, adjustment, alteration, service, maintenance, or use can cause explosion, fire, electrical shock, or other conditions which may cause death, personal injury, or property damage. Consult a qualified installer, service agency, or your distributor or branch for information or assistance. The qualified installer or agency must use factory-authorized kits or accessories when modifying this product. Refer to the individual instructions packaged with the kits or accessories when installing.

Follow all safety codes. Wear safety glasses, protective clothing, and work gloves. Use quenching cloth for brazing operations. Have fire extinguisher available. Read these instructions thoroughly and follow all warnings or cautions included in literature and attached to the unit. Consult local building codes and National Electrical Code (NEC) for special requirements.

Recognize safety information. This is the safety-alert symbol . When you see this symbol on the unit and in instructions or manuals, be alert to the potential for personal injury.

Understand these signal words: DANGER, WARNING, and CAUTION. These words are used with the safety-alert symbol. DANGER identifies the most serious hazards which **will** result in severe personal injury or death. WARNING signifies hazards which **could** result in personal injury or death. CAUTION is used to identify unsafe practices which **may** result in minor personal injury or product and property damage. NOTE is used to highlight suggestions which **will** result in enhanced installation, reliability, or operation.

WARNING

ELECTRICAL SHOCK HAZARD

Failure to follow this warning could result in personal injury or death.

Before installing, modifying, or servicing system, main electrical disconnect switch must be in the OFF position. There may be more than 1 disconnect switch. Lock out and tag switch with a suitable warning label.

INTRODUCTION

Section 1 of this Service Manual provides the necessary information to service, repair, and maintain the EEZ family of Puron air conditioners and heat pumps. Section 2 of this manual is an appendix with data required to perform troubleshooting. Use the Table of Contents to locate a desired topic.

MODEL NUMBER NOMENCLATURE

38/40MVC, MVQ

INDOOR UNIT

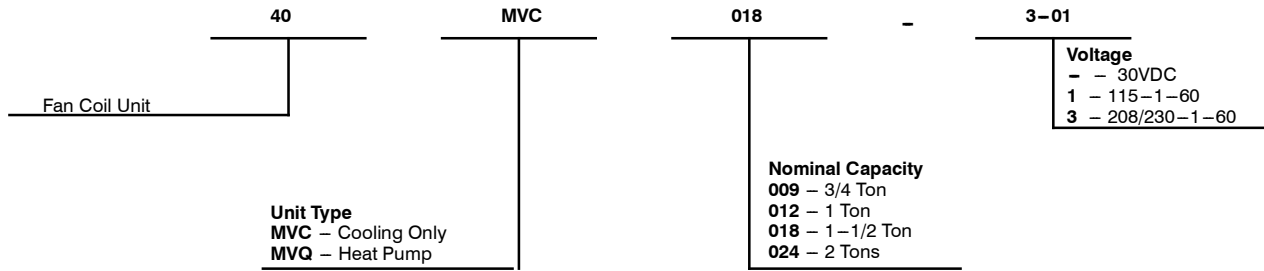

OUTDOOR UNIT

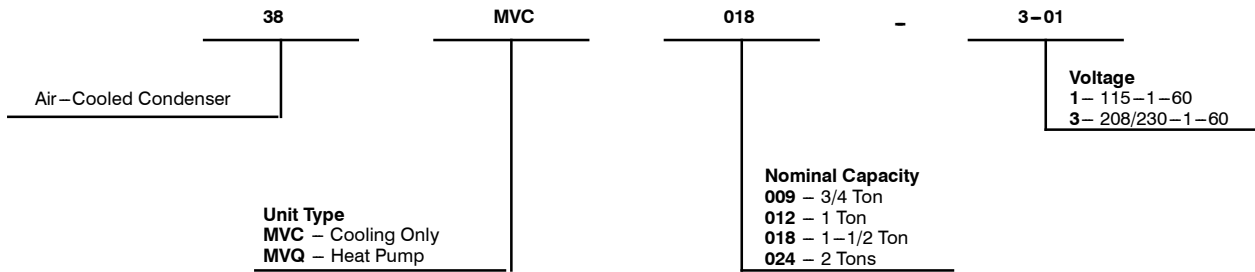

SERIAL NUMBER NOMENCLATURE

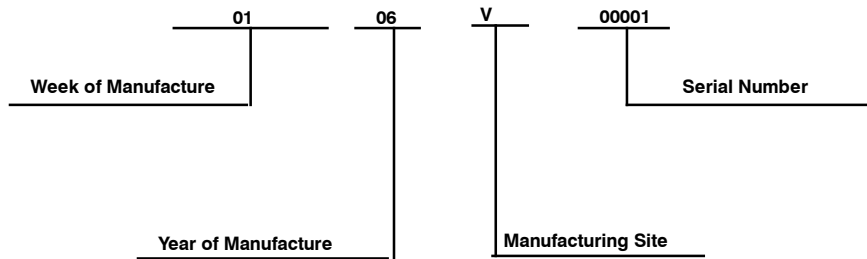

STANDARD FEATURES AND ACCESSORIES

Ease Of Installation	
Mounting Brackets	S
Low Voltage Controls	S
Comfort Features	
Microprocessor Controls	S
Wireless Remote Control	S
Automatic Air Sweep	S
Air Direction Control	S
Auto Restart Function	S
Cold Blow Protection On Heat Pumps	S
Turbo Mode On Sizes 9K and 12 K	S
Auto Changeover On Heat Pumps	S
Energy Saving Features	
Sleep Mode	S
Stop/Start Timer	S
Safety And Reliability	
3 Minute Time Delay For Compressor	S
Over Current Protection For Compressor	S
Indoor Coil Freeze Protection	S
Indoor Coil High Temperature Protection On Heat Pumps	S
Condenser High Temperature Protection On heat Pumps†	S
Accumulator On Heat Pumps	S
Ease Of Service And Maintenance	
Cleanable Filters	S
Diagnostics	S
Liquid Line Pressure Taps	S
Suction And Discharge Pressure Taps (Sizes 18 and 24K)	S
Application Flexibility	
Low Ambient Controls (-20° F)	A
Condensate Pumps	A
Crankcase Heater	A
Wind Baffles	F
Warranty	
5 - Year Compressor Warranty	S
1 - Parts Warranty	S
Compressor Extended Warranty Years 6 Thru 10	O
All Parts And Labor Years 2 Thru 5	O
All Parts And Labor Years 2 Thru 5, Compressor Years 6 Thru 10	O

† Sizes 18k & 24k

Legend

- S Standard
- A Accessory
- O Optional
- F Field Fabricated

INDOOR UNITS

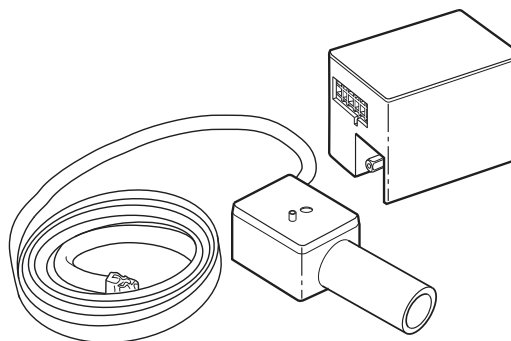

A07892

Fig. 1 – Condensate Pump

On high wall fan coils, the condensate pump has a lift capability of 18 ft (5.5 m) or the discharge side with the pump mounted in the fan coil or 6 ft (1.8 m) on the suction side if the pump must be remote mounted. The pump mounts inside the unit with quick plug-in connections, and is recommended when adequate drain line pitch cannot be provided, or when the condensate must move up to exit.

NOTE: An external 115v power source will be required to run the pump on unit sizes 9k and 12k.

OUTDOOR UNITS

LOW AMBIENT KIT

The kit controls condenser fan cycling using a pressure switch. It is specifically designed to control fan-motor cycles in response to saturated condensing pressure. This device maintains a constant saturated condensing temperature of 100 °F ± 10 °F (37.78°C ± -12.22 °C) at outdoor-air temperatures between 55 °F and -20 °F (12.78°C ± -12.22°C), and can be used on all outdoor units without changing the outdoor fan motor.

CRANKCASE HEATER

Available for units with rotary compressors. Heater clamps around compressor oil sump. Recommended for low-ambient applications on sizes 9, 12, 18, 24 and long line applications.

38/40MVC, MVQ

SPECIFICATIONS - COOLING ONLY UNITS

38/40MVC, MVQ

	System Model Number	53MVC009---1	53MVC012---1	53MVC012---3	53MVC018---3
System	System Voltage	115 V	115 V	208/230	208/230
	Control Voltage	0 – 12 Pulse DC	0 – 12 Pulse DC	0 – 12 Pulse DC	Pulse DC
	Capacity (Btuh)	9000	12000	12000	18000
	SEER	13.0	13.0	13.0	13.0
Refrigerant	Refrigerant Type	R-410A			
	Design Pressure (PSIG)	550	550	550	550
	Metering Device	Capillary Tube in Outdoor Unit			
	Charge (lb)	2.3	2.9	3.0	4.4
Compressor	Type	Rotary			
	Model	EA82X1C-1FZDU1	EA108X1C-1FZDU1	PA108X1C-3FZDU	PA150X2CS-3KUJ
	Oil Charge (POE -oz)	11.8	11.8	11.8	25.4
	Capacitor	45µF/250VAC	45µF/250VAC	35µF/370VAC	40µF/370VAC
	Rated Current (RLA)	7.5	9.9	5.2	7.3
	Locked Rotor Amp (LRA)	40	47	21	32.6
Outdoor Motor	Rpm/CFM	900/1060	900/1090	900/1120	840/1470
	Diameter (in) .. No. of Blades	15.8 ... 3	15.8 ... 3	15.8 ... 3	18.1 ... 3
	Motor (hp)	0.102	0.102	0.102	0.224
	Capacitor	6.5µF/260VAC	6.5µF/260VAC	2.5µF/450VAC	3µF/450VAC
Outdoor Coil	Face Area (sq. ft)	4.05	3.94	3.94	5.51
	No. Rows	2	2	2	4
	Fins per inch	17	17	17	18
	Circuits	4	4	4	4
Indoor Motor	Motor Watts/HP	20/.034	20/.034	20/.034	25/.044
	Rpm/Cfm (High)	1250/325	1270/425	1270/425	1070/630
	Rpm/Cfm (Medium)	1000/260	1100/365	1100/365	1000/570
	Rpm/Cfm (Low)	800/190	1000/340	1000/340	960/500
	Blower Diameter ... Length (in)	3.84 ... 25.87	4.17 ... 25.2	4.17 ... 25.2	4.21 ... 37.6
Indoor Coil	Face Area (sq. ft)	2.15	2.54	2.54	4.36
	No. Rows	2	2	2	2
	Fins per inch	19.5	19.5	19.5	19.5
	Circuits	2	3	3	6
Refrigerant Lines	Connection Type	Flare			
	Liquid (Mix Phase) (in) OD	1/4"	1/4"	1/4"	1/4"
	Vapor Line (in) OD	3/8"	1/2"	1/2"	1/2"
	Condensate Drain (in)	.65 (OD) .53 (ID)	.65 (OD) .53 (ID)	.65 (OD) .53 (ID)	.65 (OD) .53 (ID)
	Maximum Length (ft)	65	65	65	100
	Max Lift (Fan Coil Above) (ft)	35	35	35	50
	Max Drop (Fan Coil Below) (ft)	35	35	35	50

SPECIFICATIONS - HEAT PUMP UNITS

	System Model Number	53MVQ009---1	53MVQ012---1	53MVQ012---3	53MVQ018---3
System	System Voltage	115 V	115 V	208/230	208/230
	Control Voltage	0 – 12 Pulse DC	0 – 12 Pulse DC	0 – 12 Pulse DC	Pulse DC
	Capacity (Btuh)	9000	12000	12000	18000
	SEER	13.0	13.0	13.0	13.0
	HSPF	7.7	7.7	7.7	7.7
	Refrigerant	Refrigerant Type	R-410A		
Design Pressure (PSIG)		550	550	550	550
Metering Device		Capillary Tubes in Outdoor Unit			
Charge (lb)		2.35	3.0	3.0	
Compressor	Type	Rotary			
	Model	EA82X1C-1FZDU1	EA108X1C-1FZDU1	PA108X1C-3FZDU	PA150X2CS-3KUU
	Oil Charge (POE -oz)	11.8	11.8	11.8	25.4
	Capacitor	45µF/250VAC	45µF/250VAC	35µF/370VAC	40µF/370VAC
	Rated Current (RLA)	7.5	9.9	5.2	7.3
	Locked Rotor Amp (LRA)	40	47	21	32.6
Outdoor Motor	Rpm/CFM	900/1060	900/1090	900/1120	840/1470
	Diameter (in) .. No. of Blades	15.8 ... 3	15.8 ... 3	15.8 ... 3	18.1 ... 3
	Motor (hp)	0.102	0.102	0.102	0.224
	Capacitor	6.5µF/260VAC	6.5µF/260VAC	2.5µF/450VAC	3µF/450VAC
Outdoor Coil	Face Area (sq. ft)	4.05	3.94	3.94	5.51
	No. Rows	2	2	2	4
	Fins per inch	17	17	17	18
	Circuits	4	4	4	4
Indoor Motor	Motor Watts/HP	20/.034	20/.034	20/.034	25/.044
	Rpm/Cfm (High)	1250/325	1270/425	1270/425	1070/630
	Rpm/Cfm (Medium)	1000/260	1100/365	1100/365	1000/570
	Rpm/Cfm (Low)	800/190	1000/340	1000/340	960/500
	Blower Diameter ... Length (in)	3.84 ... 25.87	4.17 ... 25.2	4.17 ... 25.2	4.21 ... 37.6
Indoor Coil	Face Area (sq. ft)	2.15	2.54	2.54	4.36
	No. Rows	2	2	2	2
	Fins per inch	19.5	19.5	19.5	19.5
	Circuits	2	3	3	6
Refrigerant Lines	Connection Type	Flare			
	Liquid (Mix Phase) (in) OD	1/4"	1/4"	1/4"	1/4"
	Vapor Line (in) OD	3/8"	1/2"	1/2"	1/2"
	Condensate Drain (in)	.65 (OD) .53 (ID)	.65 (OD) .53 (ID)	.65 (OD) .53 (ID)	.65 (OD) .53 (ID)
	Maximum Length (ft)	65	65	65	100
	Max Lift (Fan Coil Above) (ft)	35	35	35	50
	Max Drop (Fan Coil Below) (ft)	35	35	35	50

38/40MVC, MVQ

DIMENSIONS - INDOOR

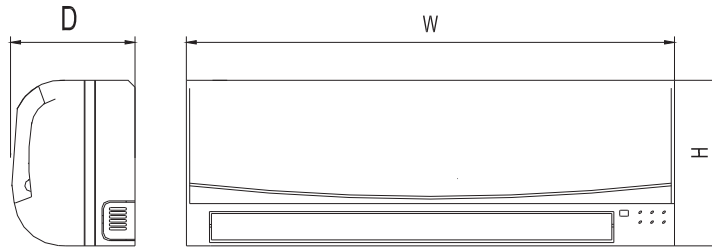

A07336

Model Size	W in. (mm)	H in. (mm)	D in. (mm)	Weight lb (kg)
9K	32.09 (815)	11.02 (280)	7.68 (195)	24.2 (11)
12K	35.67 (906)	11.26 (286)	9.25 (235)	33.0 (15)
18K	49.21 (1250)	12.80 (325)	9.06 (230)	55.0 (25)
24K	49.21 (1250)	12.80 (325)	9.06 (230)	55.0 (25)

38/40MVC, MVQ

DIMENSIONS - OUTDOOR

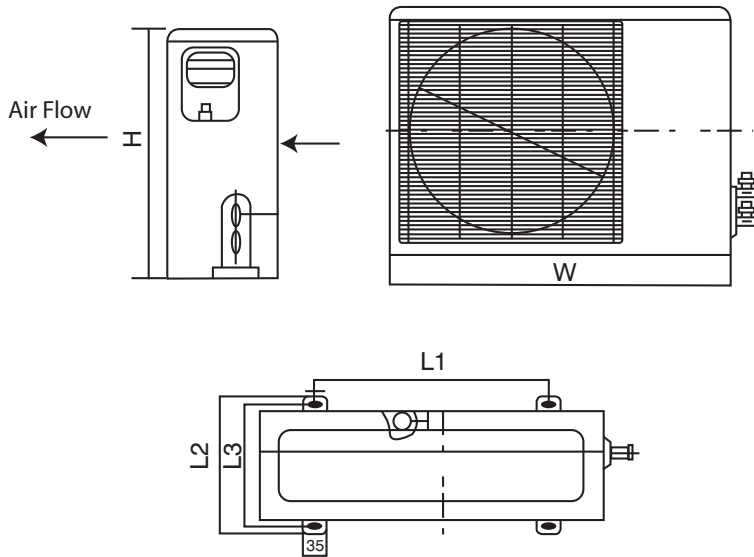

A07337

Model Size	W in. (mm)	H in. (mm)	L1 in. (mm)	L2 in. (mm)	L3 in. (mm)	Weight lb (kg) Cooling Only	Weight lb (kg) Heat Pumps
9K	30.71 (780)	21.26 (540)	21.61 (549)	11.81 (300)	10.87 (276)	77.0 (35)	79.2 (36)
12K	29.92 (760)	23.23 (590)	20.87 (530)	12.40 (315)	11.42 (290)	85.8 (39)	90.2 (41)
18K	33.07 (840)	27.36 (695)	22.05 (560)	14.17 (360)	13.19 (335)	125.4 (57)	125.4 (57)
24K	31.16 (893)	33.86 (860)	23.11 (588)	13.98 (355)	13.11 (333)	159.5 (72)	160.6 (73)

SERVICE VALVE LOCATIONS

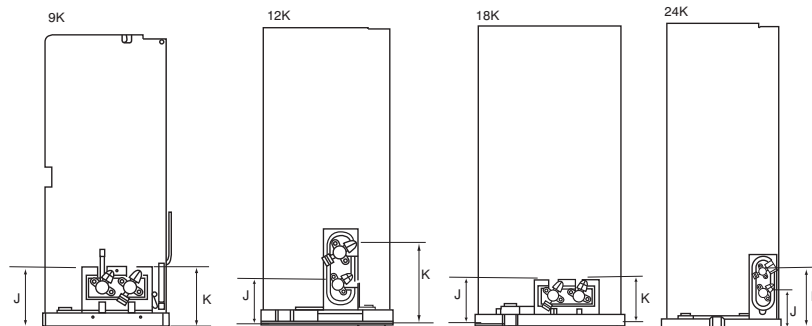

A07376a

Service Valve Locations	9K in. (mm)	12K in. (mm)	18K in. (mm)	24K in. (mm)
J	3.46 (88)	3.19 (81)	3.46 (88)	4.02 (102)
K	3.46 (88)	5.63 (143)	3.62 (92)	6.57 (167)

CLEARANCES - INDOOR

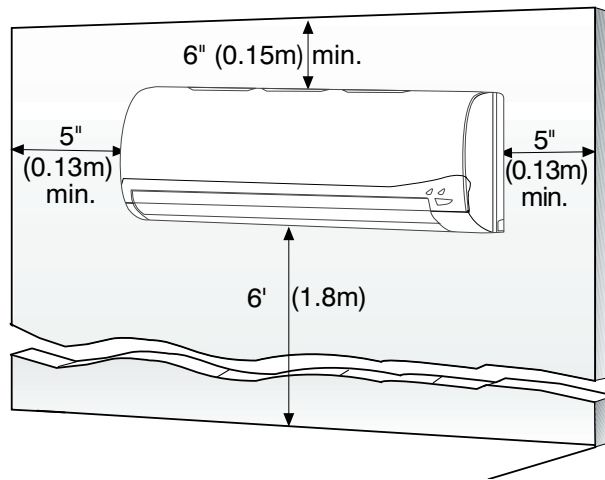

A07891

Fig. 2 – Indoor unit clearance

CLEARANCES - OUTDOOR

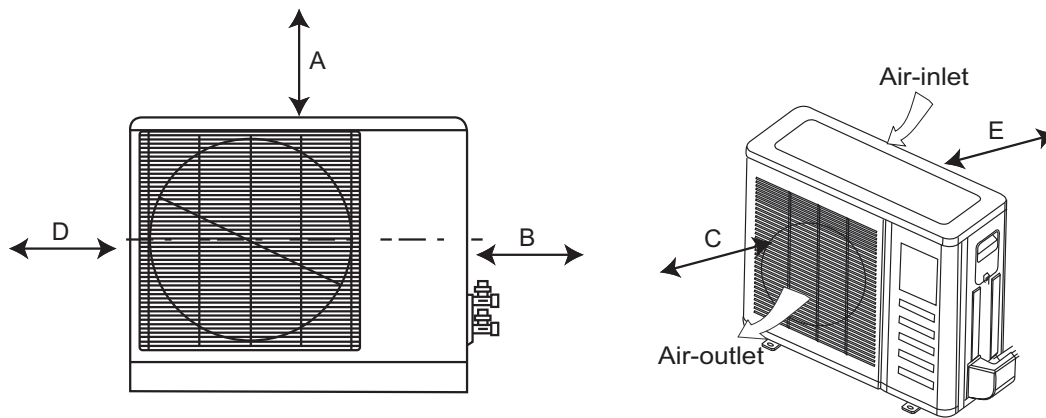

A07894

UNIT	9k and 12k in. (mm)	18k and 24k in. (mm)
A	24 (610)	24 (610)
B	24 (610)	36 (914)
C	24 (610)	24 (610)
D	4 (102)	12 (305)
E	12 (305)	12 (305)

Fig. 3 – Outdoor Unit Clearance

SYSTEM OPERATING ENVELOPE

53MVC/MVQ System Operating Envelope Chart

38/40MVC, MVQ

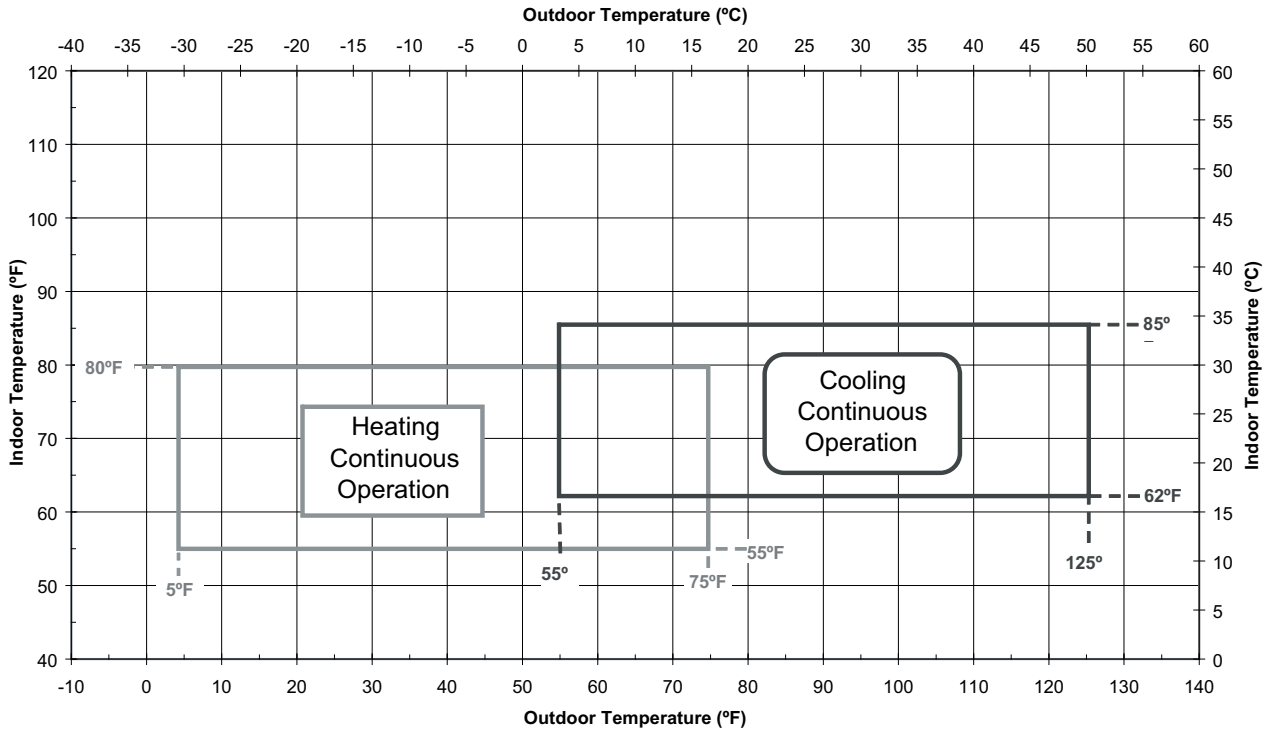

Use low ambient control if the unit will operate in cooling at ambient conditions below 55°F (12.78°C).

Fig. 4 – System Operating Envelope

A08180

ELECTRICAL DATA

UNIT SIZE	OPERATING VOLTAGE*	COMPRESSOR		OUTDOOR FAN			INDOOR FAN				MCA	MAX FUSE/CB AMP	
	MAX/MIN	VOLTS-PH-HZ	RLA	LRA	FLA	HP	W	VOLTS	FLA	HP			W
009	127/104	115-1-60	7.5	40	0.60	0.102	23	35 DC	1.1	0.034	20	12	20
012			9.9	47					1.18	0.044	25		
012	253/187	208/230-1-60	5.2	21	0.38	0.116	36	35 DC	1.18	0.044	25	9	15
018			7.3	32.6	0.78	0.224	53	208/230-1-60	0.26	0.075	31	11	20
024			9.7	34.8	0.62	0.218	100		0.39	0.112	50	14	25

*Permissible limits of the voltage range at which the unit will operate satisfactorily

LEGEND

- FLA – Full Load Amps
- LRA – Locked Rotor Amps
- MCA – Minimum Circuit Amps
- RLA – Rated Load Amps

WIRING

The main power is supplied to the outdoor unit. The field supplied connecting cable from the outdoor unit to indoor unit consists of four wires and provides the power for the indoor unit as well as the communication signal between the outdoor unit and indoor unit.

Voltage drop on the connecting cable should be kept to a minimum. Use cable size and max length below:

18 AWG	50 ft. (16 m)
16 AWG	100 ft. (33 m)

CONNECTION DIAGRAMS

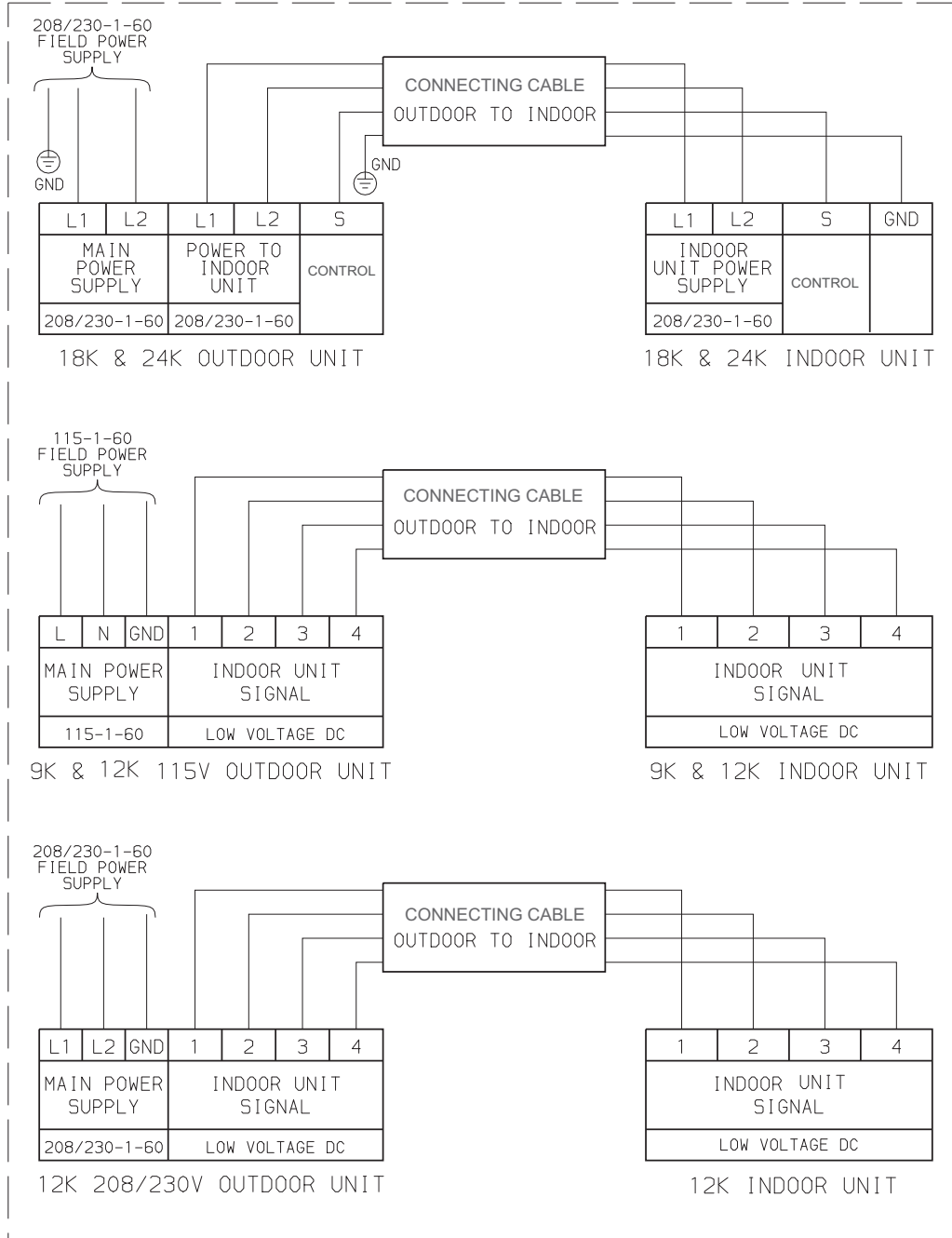

Notes:

1. Do not use thermostat wire for any connection between indoor and outdoor units.
2. All connections between indoor and outdoor units must be as shown. The connections are sensitive to polarity.
3. On the 18k and 24k units, the "S" terminal "CONTROL" output is pulse DC with a potential AC voltage shock hazard.

Fig. 5 – Connection Diagrams

A07654

WIRING DIAGRAMS

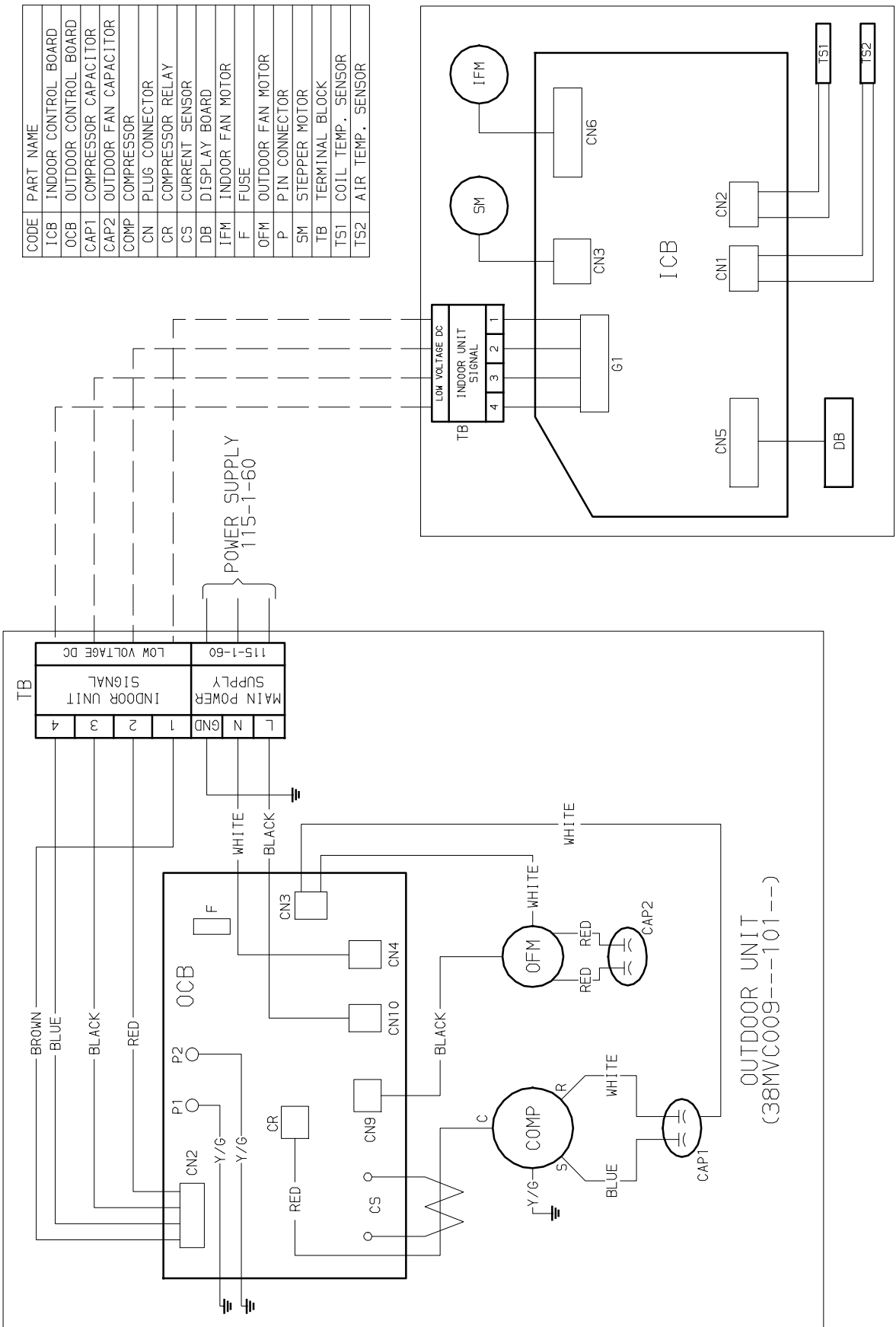

CODE	PART NAME
ICB	INDOOR CONTROL BOARD
OCB	OUTDOOR CONTROL BOARD
CAP1	COMPRESSOR CAPACITOR
CAP2	OUTDOOR FAN CAPACITOR
COMP	COMPRESSOR
CN	PLUG CONNECTOR
CR	COMPRESSOR RELAY
CS	CURRENT SENSOR
DB	DISPLAY BOARD
IFM	INDOOR FAN MOTOR
F	FUSE
OFM	OUTDOOR FAN MOTOR
P	PIN CONNECTOR
SM	STEPPER MOTOR
TB	TERMINAL BLOCK
TS1	COIL TEMP. SENSOR
TS2	AIR TEMP. SENSOR

INDOOR UNIT
(40MVC09---101---

Fig. 6 – Wiring Diagram 38MVC09---1 W/ 40MVC09---1

WIRING DIAGRAMS (CONT.)

CODE	PART NAME
ICB	INDOOR CONTROL BOARD
OCB	OUTDOOR CONTROL BOARD
CAP1	COMPRESSOR CAPACITOR
CAP2	OUTDOOR FAN CAPACITOR
COMP	COMPRESSOR
CN	PLUG CONNECTOR
CR	COMPRESSOR RELAY
CS	CURRENT SENSOR
DB	DISPLAY BOARD
IFM	INDOOR FAN MOTOR
F	FUSE
OFM	OUTDOOR FAN MOTOR
P	PIN CONNECTOR
SM	STEPPER MOTOR
TB	TERMINAL BLOCK
TS1	COIL TEMP. SENSOR
TS2	AIR TEMP. SENSOR

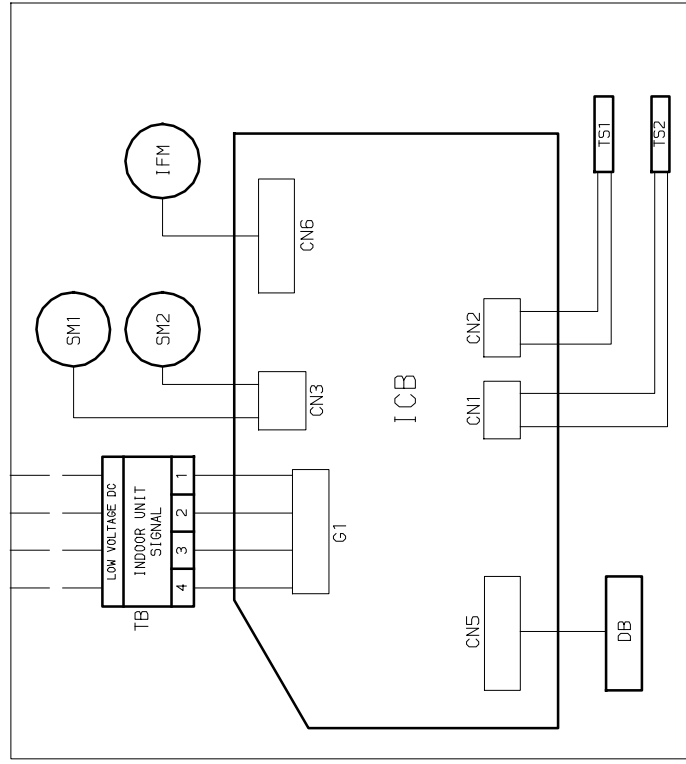
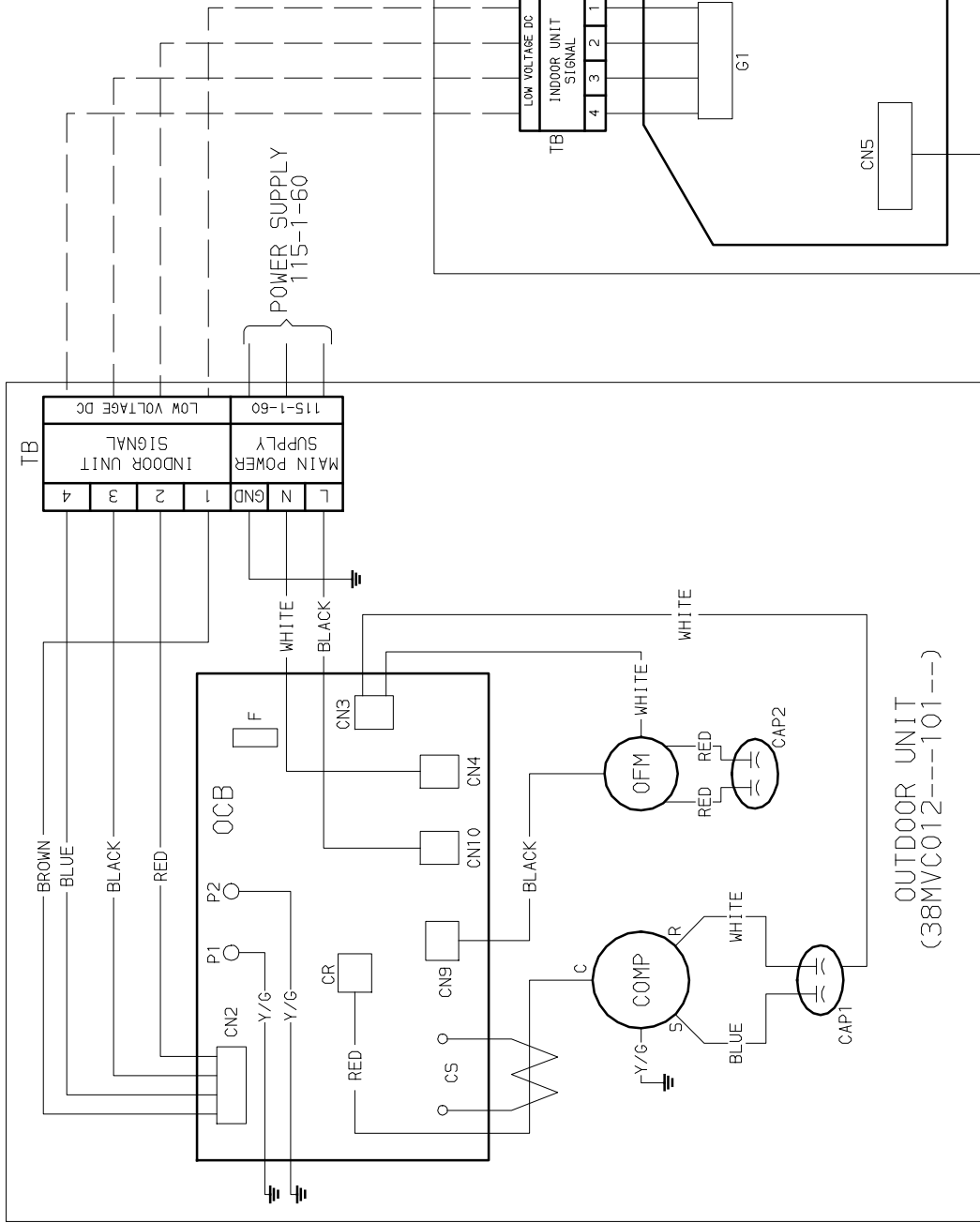

INDOOR UNIT
(40MVC012---101---

Fig. 7 – Wiring Diagram 38MVC012---1 W/ 40MVC012---1

WIRING DIAGRAMS (CONT.)

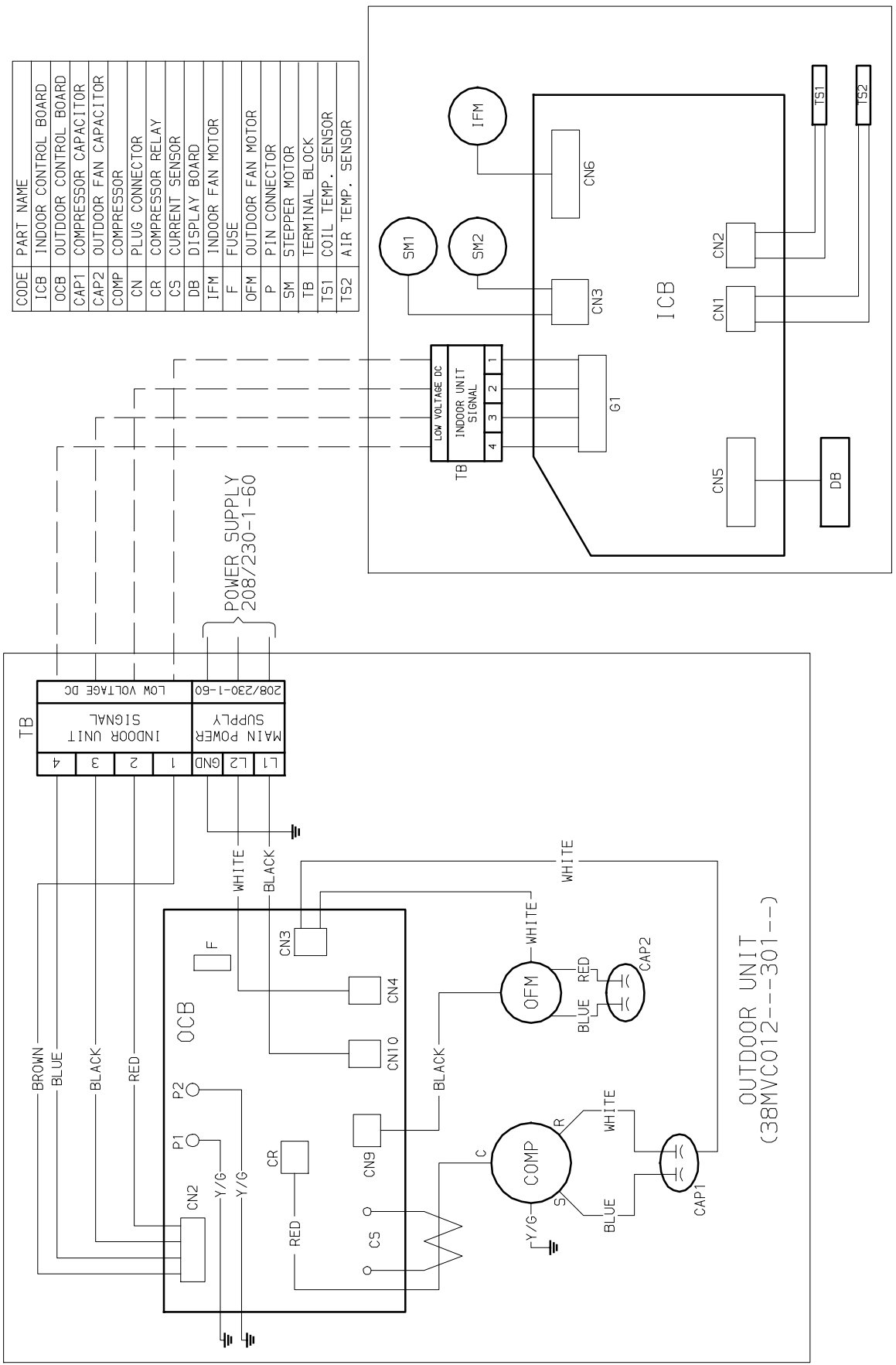
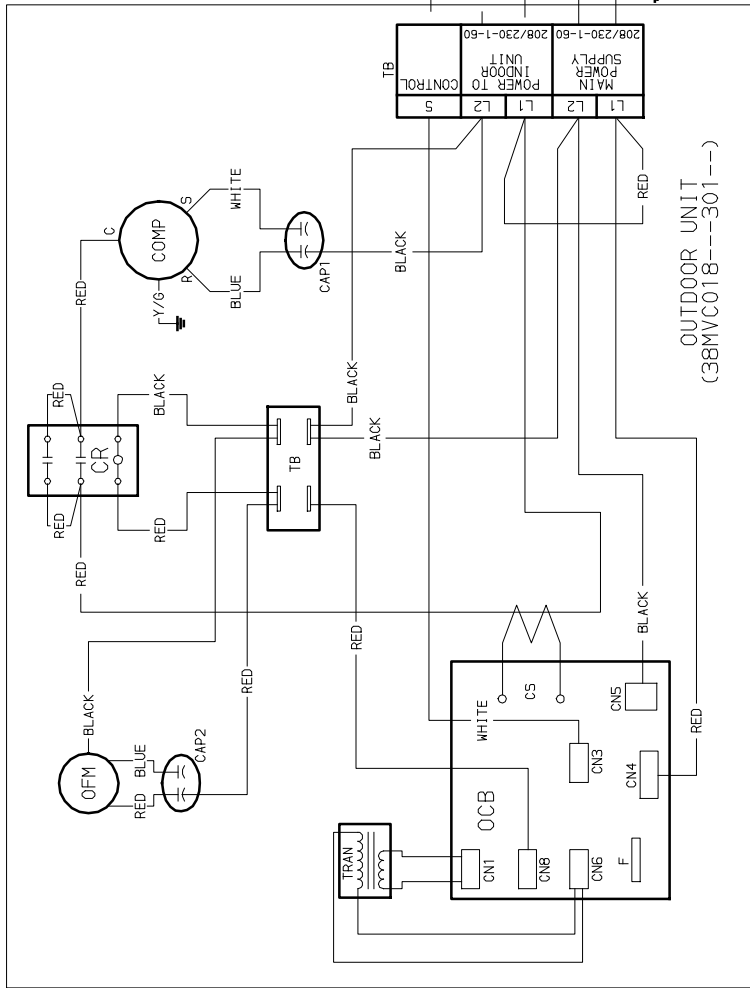

Fig. 8 - Wiring Diagram 38MVC012---3 W/ 40MVC012---3

WIRING DIAGRAMS (CONT.)



CODE	PART NAME
ICB	INDOOR CONTROL BOARD
OCB	OUTDOOR CONTROL BOARD
CAP1	COMPRESSOR CAPACITOR
CAP2	OUTDOOR FAN CAPACITOR
COMP	COMPRESSOR
CN	PLUG CONNECTOR
CR	COMPRESSOR RELAY
CS	CURRENT SENSOR
DB	DISPLAY BOARD
IFM	INDOOR FAN MOTOR
F	FUSE
OFM	OUTDOOR FAN MOTOR
P	PIN CONNECTOR
SM	STEPPER MOTOR
TB	TERMINAL BLOCK
TRAN	TRANSFORMER
TS1	COIL TEMP. SENSOR
TS2	AIR TEMP. SENSOR

POWER SUPPLY
208/230-1-60

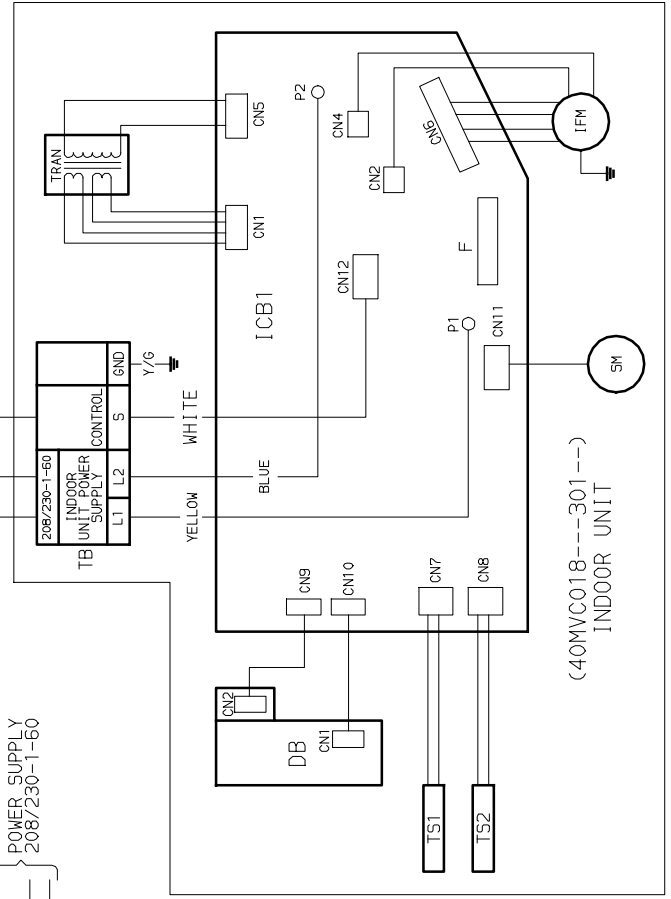

(40MVC018---301---)
INDOOR UNIT

Fig. 9 – Wiring Diagram 38MVC018---3 W/ 40MVC018---3

WIRING DIAGRAMS (CONT.)

CODE	PART NAME
ICB	INDOOR CONTROL BOARD
OCB	OUTDOOR CONTROL BOARD
CAP1	COMPRESSOR CAPACITOR
CAP2	OUTDOOR FAN CAPACITOR
COMP	COMPRESSOR
CN	PLUG CONNECTOR
CR	COMPRESSOR RELAY
CS	CURRENT SENSOR
DB	DISPLAY BOARD
IFM	INDOOR FAN MOTOR
F	FUSE
OFM	OUTDOOR FAN MOTOR
P	PIN CONNECTOR
SM	STEPPER MOTOR
TB	TERMINAL BLOCK
TRAN	TRANSFORMER
TS1	COIL TEMP. SENSOR
TS2	AIR TEMP. SENSOR

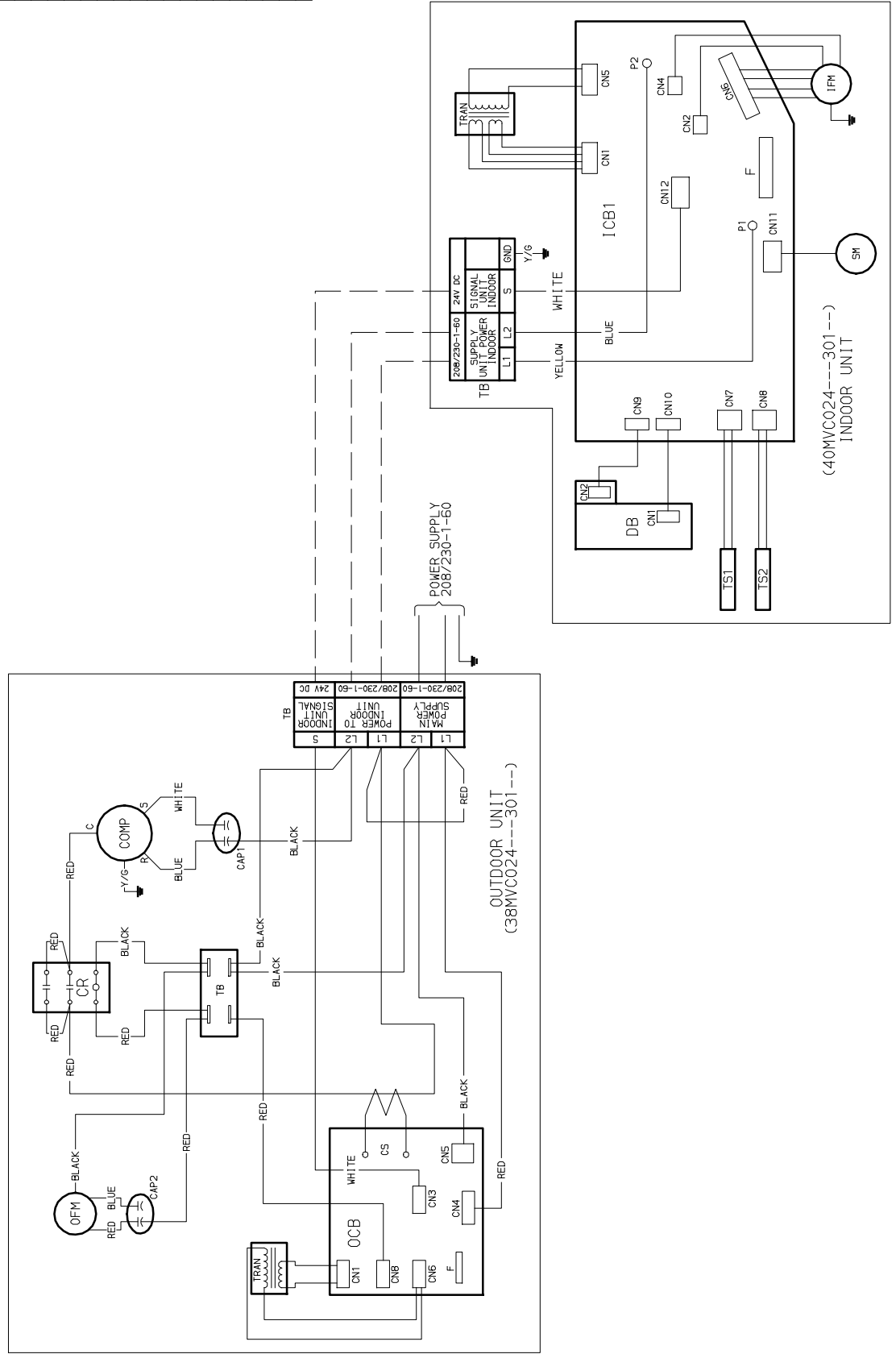
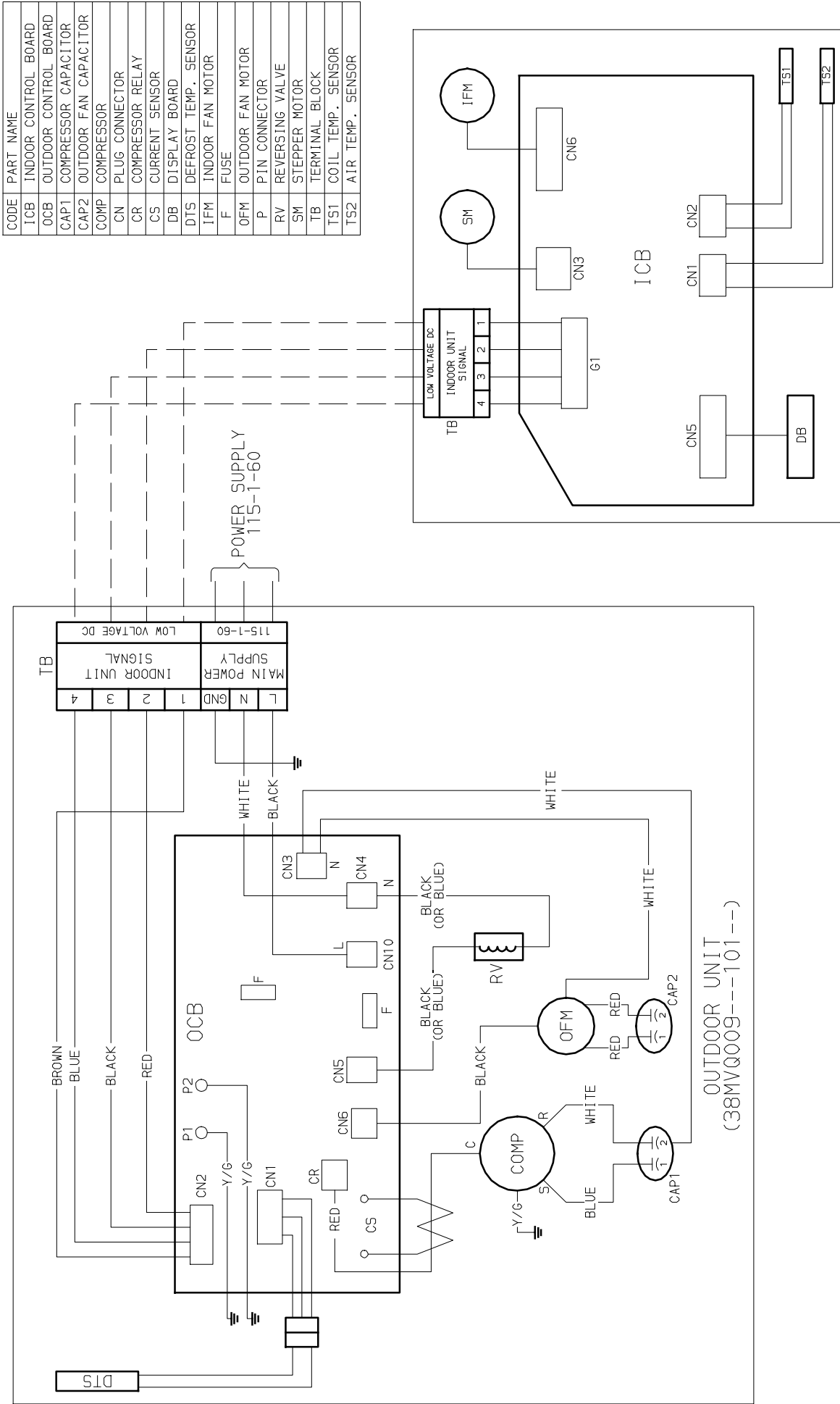

Fig. 10 – Wiring Diagram 38MVC024----3 W/ 40MVC024----3

WIRING DIAGRAMS (CONT.)



CODE	PART NAME
ICB	INDOOR CONTROL BOARD
OCB	OUTDOOR CONTROL BOARD
CAP1	COMPRESSOR CAPACITOR
CAP2	OUTDOOR FAN CAPACITOR
COMP	COMPRESSOR
CN	PLUG CONNECTOR
CR	COMPRESSOR RELAY
CS	CURRENT SENSOR
DB	DISPLAY BOARD
DTS	DEFROST TEMP. SENSOR
IFM	INDOOR FAN MOTOR
F	FUSE
OFM	OUTDOOR FAN MOTOR
P	PIN CONNECTOR
RV	REVERSING VALVE
SM	STEPPER MOTOR
TB	TERMINAL BLOCK
TS1	COIL TEMP. SENSOR
TS2	AIR TEMP. SENSOR

INDOOR UNIT
(40MVQ009---101---)

Fig. 11 - Wiring Diagram 38MVQ009---1 W/ 40MVQ009---1

WIRING DIAGRAMS (CONT.)

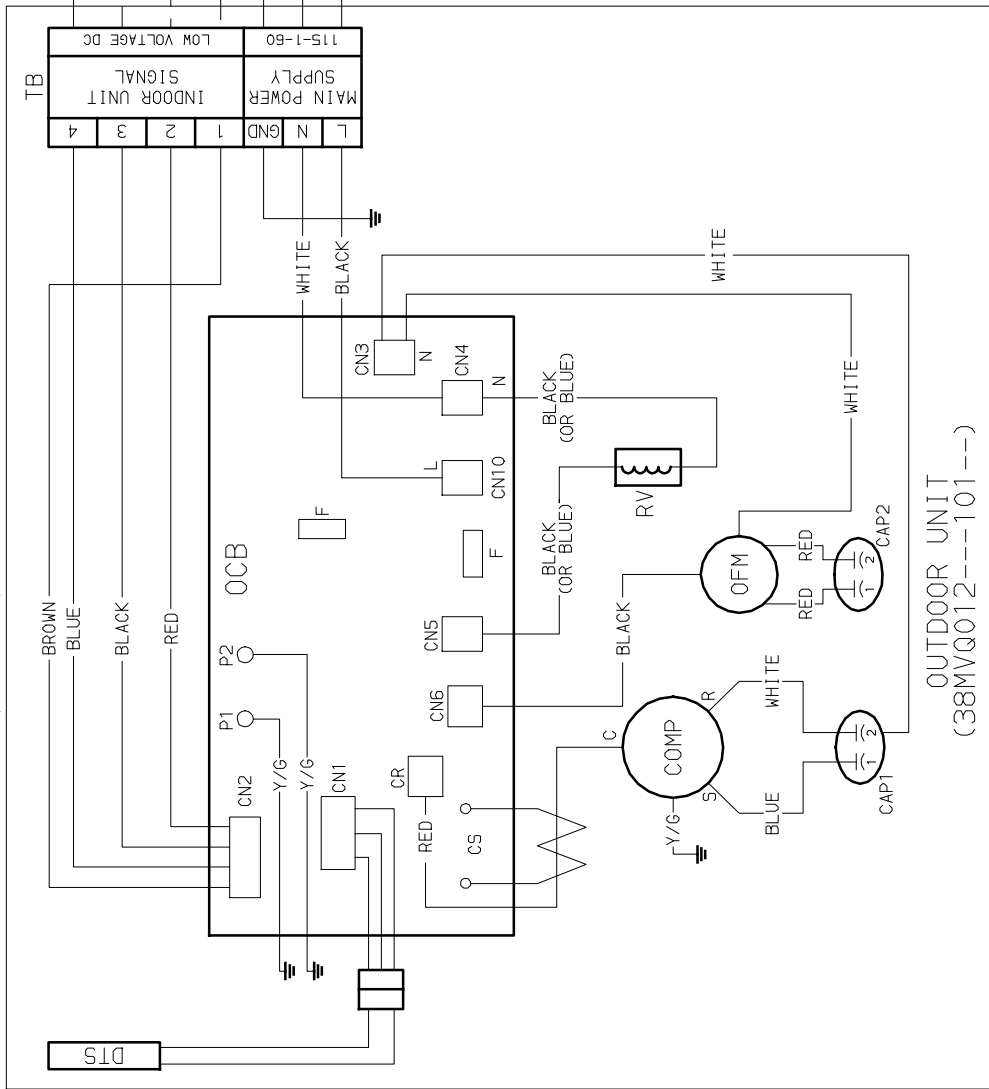

CODE	PART NAME
ICB	INDOOR CONTROL BOARD
OCB	OUTDOOR CONTROL BOARD
CAP1	COMPRESSOR CAPACITOR
CAP2	OUTDOOR FAN CAPACITOR
COMP	COMPRESSOR
CN	PLUG CONNECTOR
CR	COMPRESSOR RELAY
CS	CURRENT SENSOR
DB	DISPLAY BOARD
IFM	INDOOR FAN MOTOR
F	FUSE
OFM	OUTDOOR FAN MOTOR
P	PIN CONNECTOR
SM	STEPPER MOTOR
TB	TERMINAL BLOCK
TS1	COIL TEMP. SENSOR
TS2	AIR TEMP. SENSOR

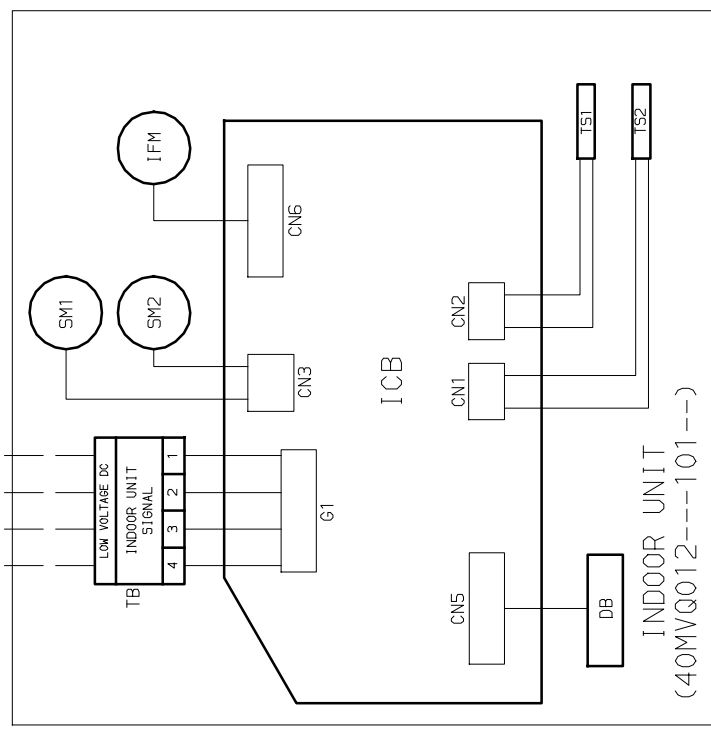

Fig. 12 - Wiring Diagram 38MVQ012---1 W/ 40MVQ012---1

WIRING DIAGRAMS (CONT.)

CODE	PART NAME
ICB	INDOOR CONTROL BOARD
OCB	OUTDOOR CONTROL BOARD
CAP1	COMPRESSOR CAPACITOR
CAP2	OUTDOOR FAN CAPACITOR
COMP	COMPRESSOR
CN	PLUG CONNECTOR
CR	COMPRESSOR RELAY
CS	CURRENT SENSOR
DB	DISPLAY BOARD
IFM	INDOOR FAN MOTOR
F	FUSE
OFM	OUTDOOR FAN MOTOR
P	PIN CONNECTOR
SM	STEPPER MOTOR
TB	TERMINAL BLOCK
TS1	COIL TEMP. SENSOR
TS2	AIR TEMP. SENSOR

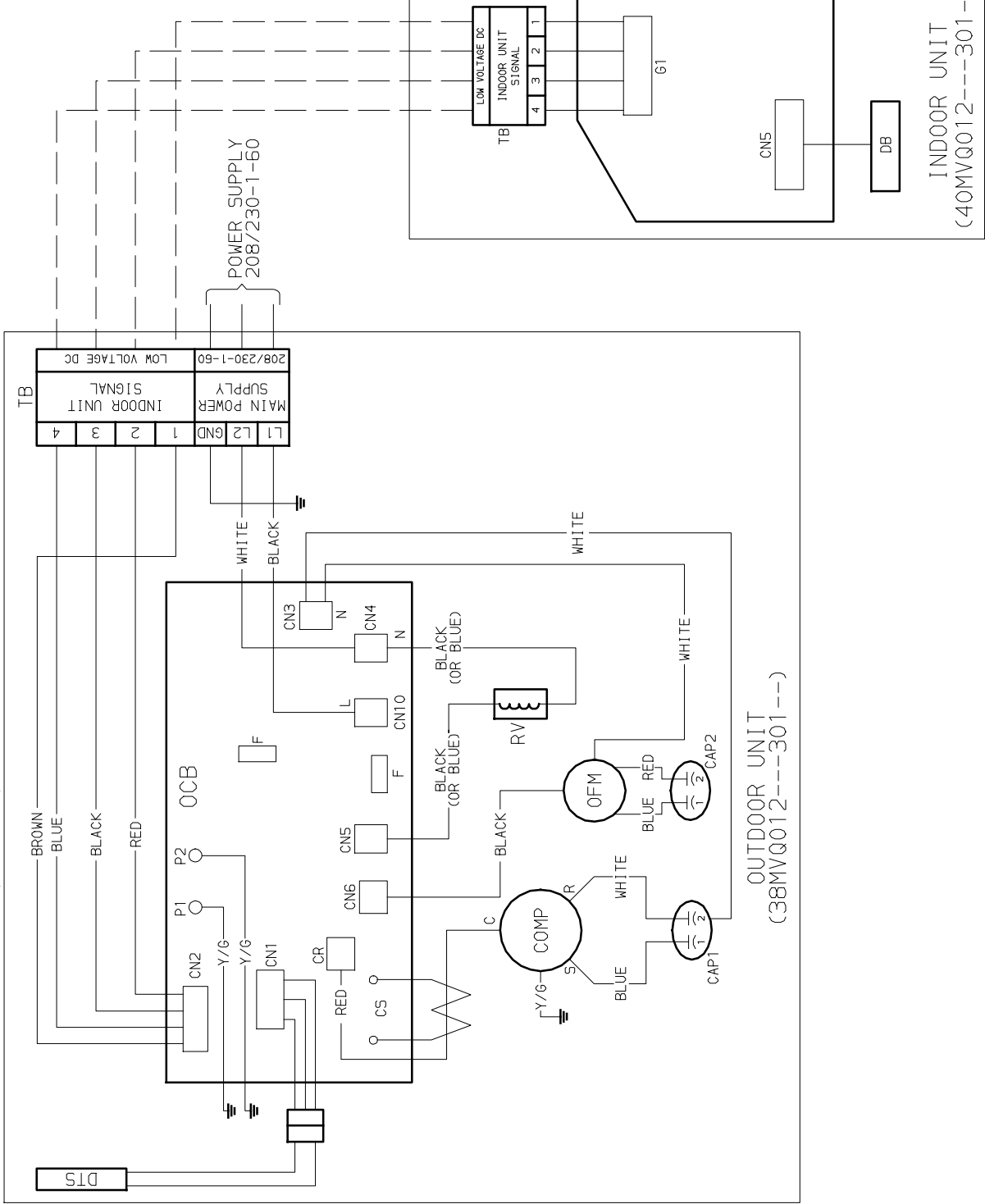

Fig. 13 – Wiring Diagram 38MVQ012----3 W/ 40MVQ012----3

WIRING DIAGRAMS (CONT.)

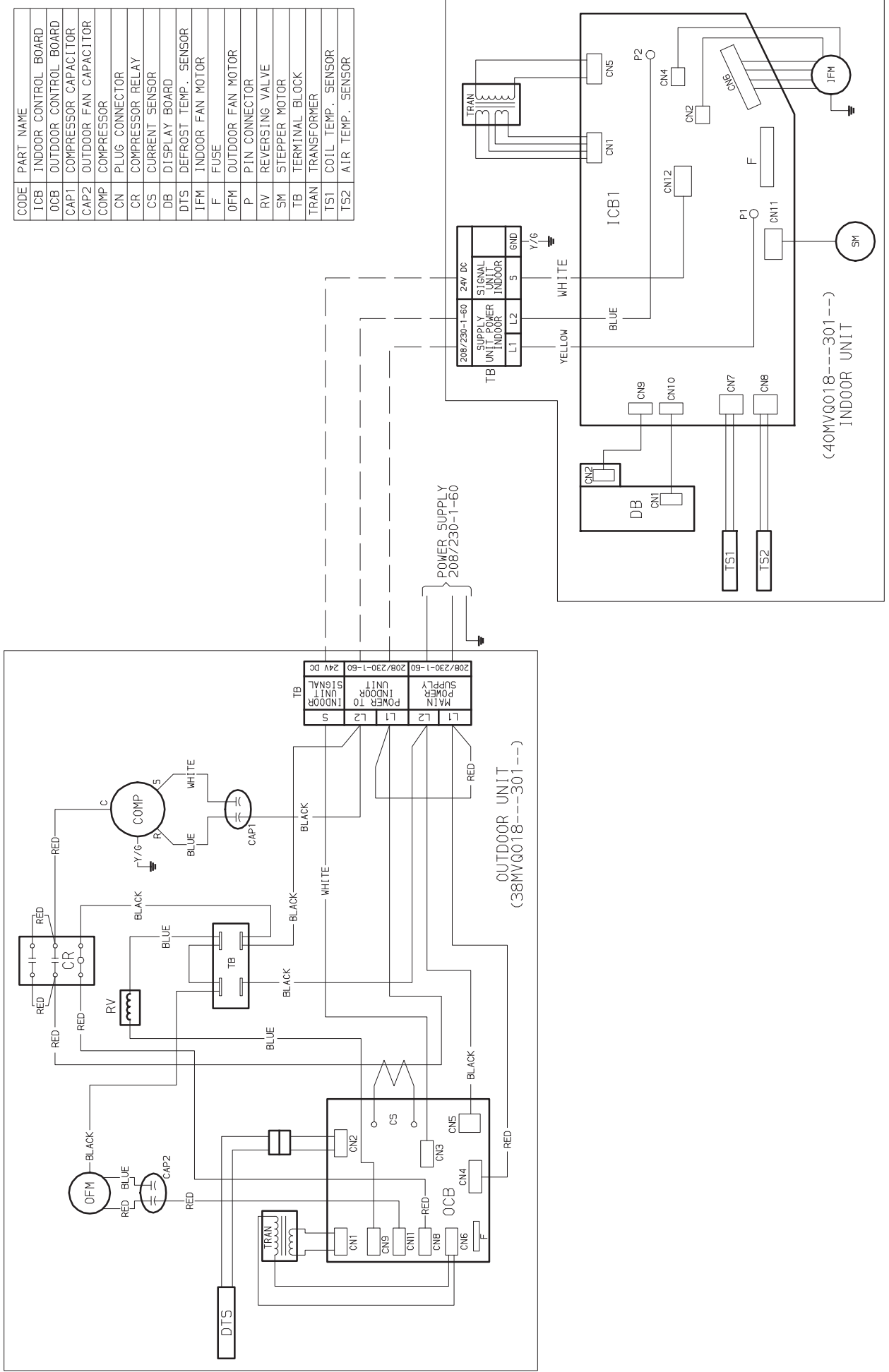
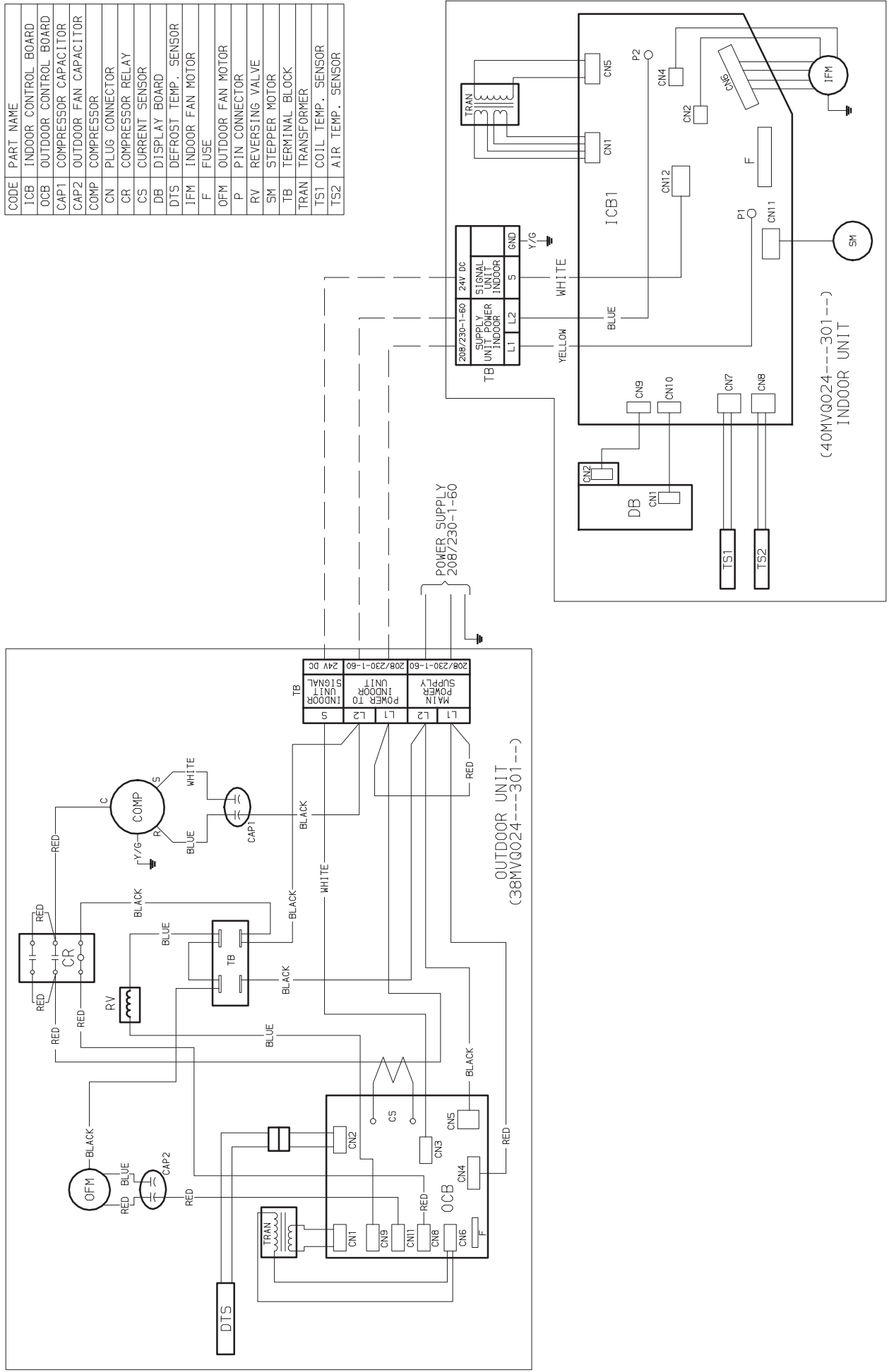

Fig. 14 - Wiring Diagram 38MVQ018---3 W/ 40MVQ018---3

WIRING DIAGRAMS (CONT.)



CODE	PART NAME
ICB	INDOOR CONTROL BOARD
OCB	OUTDOOR CONTROL BOARD
CAP1	COMPRESSOR CAPACITOR
CAP2	OUTDOOR FAN CAPACITOR
COMP	COMPRESSOR
CN	PLUG CONNECTOR
CR	COMPRESSOR RELAY
CS	CURRENT SENSOR
DB	DISPLAY BOARD
DTS	DEFROST TEMP. SENSOR
IFM	INDOOR FAN MOTOR
F	FUSE
OFM	OUTDOOR FAN MOTOR
P	PIN CONNECTOR
RV	REVERSING VALVE
SM	STEPPER MOTOR
TB	TERMINAL BLOCK
TRAN	TRANSFORMER
TS1	COIL TEMP. SENSOR
TS2	AIR TEMP. SENSOR

Fig. 15 – Wiring Diagram 38MVQ024----3 W/ 40MVQ024----3

REFRIGERATION CYCLE DIAGRAM

38/40MVC, MVQ

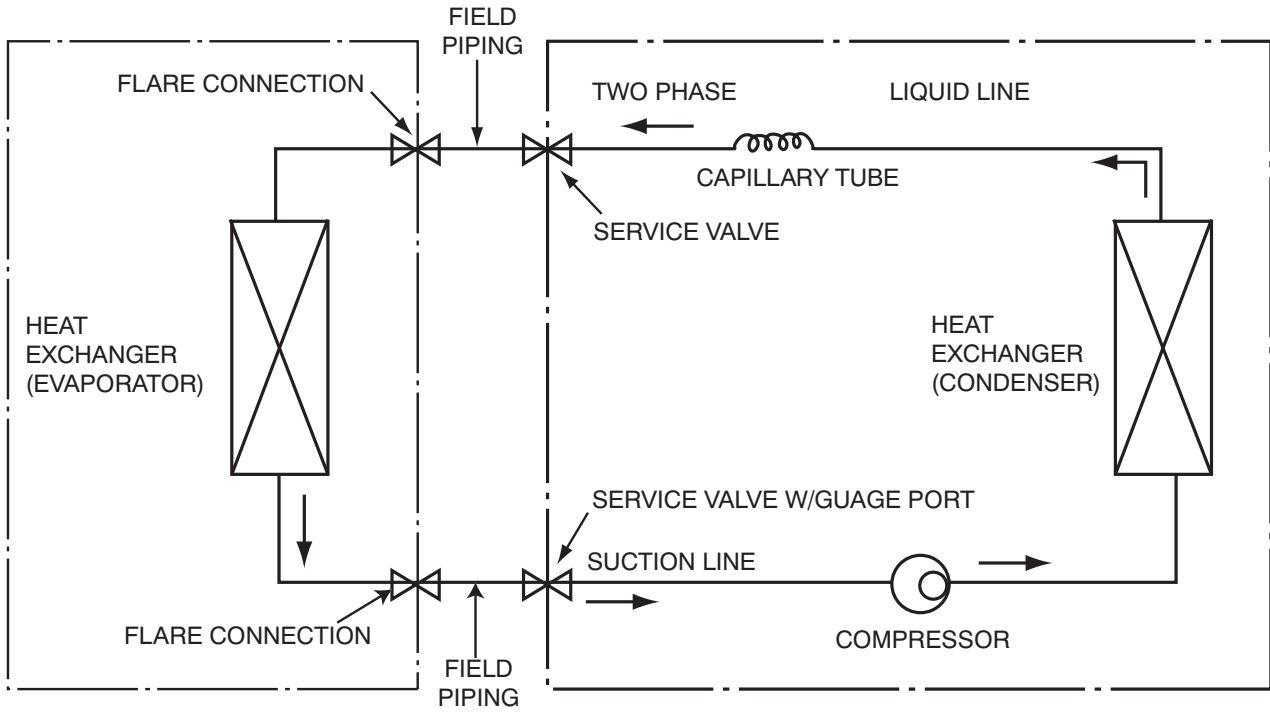

Fig. 16 - Cooling

A08104

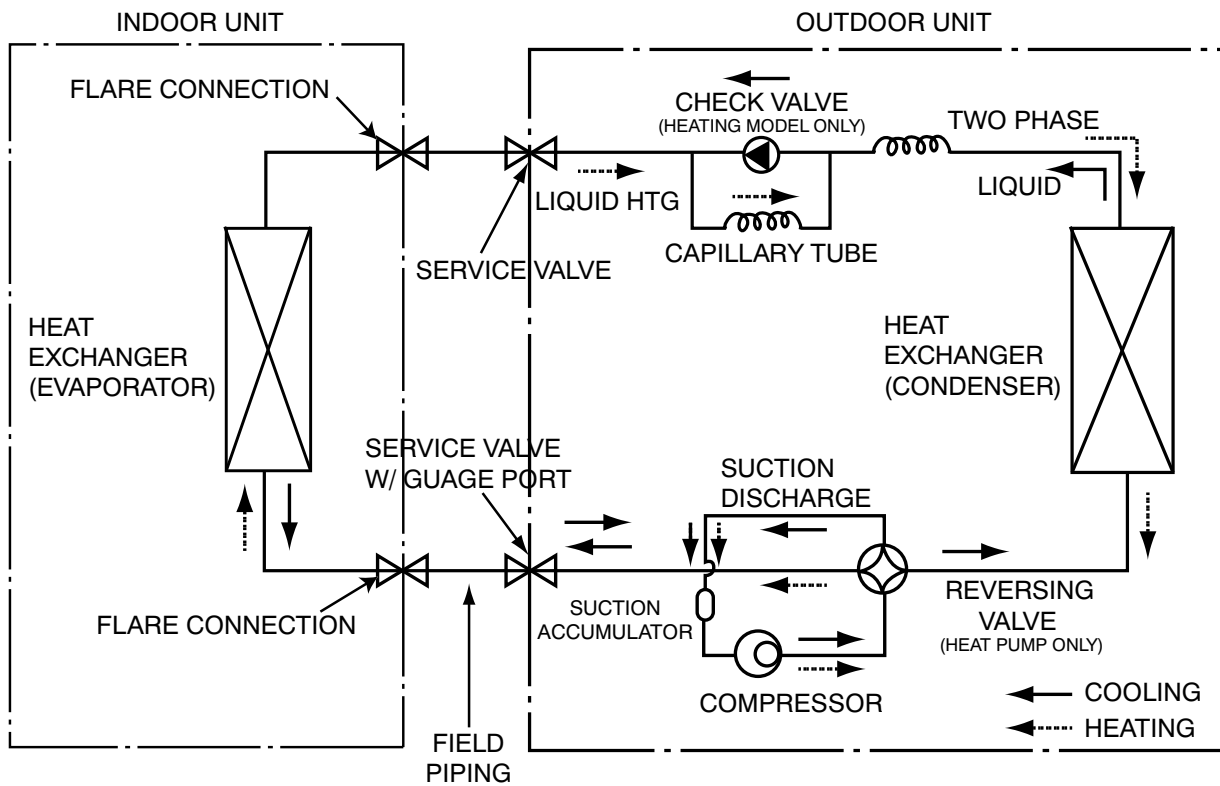

Fig. 17 - Heat Pumps

A08105

REFRIGERANT LINES

General refrigerant line sizing:

- The 38MVC/MVQ units are shipped with a full charge of R410A refrigerant. All charges, line sizing, and capacities are based on runs of 25 ft (7.6 m). For runs over 25 ft (7.6 m), consult long-line section on this page for proper charge adjustments.
 - Minimum refrigerant line length between the indoor and outdoor units is 10 ft. (3 m).
 - Refrigerant lines should not be buried in the ground. If it is necessary to bury the lines, not more than 36-in (914 mm) should be buried. Provide a minimum 6-in (152 mm) vertical rise to the service valves to prevent refrigerant migration.
 - Both lines must be insulated. Use a minimum of 1/2-in. (12.7 mm) thick insulation. Closed-cell insulation is recommended in all long-line applications.
 - Special consideration should be given to isolating interconnecting tubing from the building structure. Isolate the tubing so that vibration or noise is not transmitted into the structure.
- The following maximum lengths are allowed:

REFRIGERANT LINE LENGTHS ft. (m)			
Unit Size	Max Line Length	Max Elevation (ID over OD)	Max Elevation (OD over ID)
9K	65 (20)	35 (11)	35 (11)
12K	65 (20)	35 (11)	35 (11)
18K	100 (30)	50 (15)	50 (15)
24K	100 (30)	60 (18)	60 (18)

- The following are the piping sizes.

Unit Size	PIPE SIZES	
	Mix Phase	Vapor
9K	1/4"	3/8"
12K	1/4"	1/2"
18K	1/4"	1/2"
24K	3/8"	5/8"

Refrigerant Charge

REFRIGERANT CHARGE lb. (kg)		
Unit Size	Air Conditioner	Heat Pump
9K	2.3 (1.0)	2.4 (1.1)
12K	2.9 (1.3)	3.0 (1.4)
18K	4.4 (2.0)	TBD
24K	TBD	TBD

- Above charge is for piping runs up to 25 ft. (7.6 m).
- For piping runs greater than 25 ft. (7.6 m), add 0.1 oz. of refrigerant per foot of extra piping up to the allowable length.

Long Line Applications, 38MVC Units:

- A crankcase heater should be added for line lengths longer than 25 ft (7.62 m) to prevent the migration of refrigerant to the compressor during the "OFF" cycle.
- A field fabricated wind baffle is recommended.
- No change in line sizing is required.
- Add refrigerant per table below.

ADDITIONAL CHARGE TABLE

Unit Size	Total Line Length, ft		Additional Charge, oz.		
	Min.	Max.	10 – 25 ft (3.05 – 7.62m)	>25 – 65 ft (7.62–19.81m)	>65 – 100 ft (19.81–30.48m)
9K cool only	10	65	none	0.1 oz per foot	0.1 oz. per foot
9K hp					
12K cool only					
12K hp					
18K cool only		100			

- Reduction in capacity due to long lines can be calculated from the chart below.

CAPACITY LOSS

	Capacity, % Loss			
	Line Length, ft			
Cooling:	25	45	65	100
9 & 12 KBTU/H models	0%	2%	5%	7%
18 & 24 KBTU/H models	0%	2%	4%	7%
Heating:				
9 & 12 KBTU/H models	0%	7%	11%	15%
18 & 24 KBTU/H models	0%	7%	11%	15%

38/40MVC, MVQ

SYSTEM EVACUATION AND CHARGING

CAUTION

UNIT DAMAGE HAZARD

Failure to follow this caution may result in equipment damage or improper operation.

Never use the system compressor as a vacuum pump.

Refrigerant tubes and indoor coil should be evacuated using the recommended deep vacuum method of 500 microns. The alternate triple evacuation method may be used if the procedure outlined below is followed. Always break a vacuum with dry nitrogen.

SYSTEM VACUUM AND CHARGE

Using Vacuum Pump

1. Completely tighten flare nuts A, B, C, D, connect manifold gage charge hose to a charge port of the low side service valve. (See Fig. 18.)
2. Connect charge hose to vacuum pump.
3. Fully open the low side of manifold gage. (See Fig. 19)
4. Start vacuum pump
5. Evacuate using either deep vacuum or triple evacuation method.
6. After evacuation is complete, fully close the low side of manifold gage and stop operation of vacuum pump.
7. The factory charge contained in the outdoor unit is good for up to 25 ft. (8 m) of line length. For refrigerant lines longer than 25 ft (8 m), add 0.1 oz. per foot of extra piping up to the maximum allowable length.
8. Disconnect charge hose from charge connection of the low side service valve.
9. Fully open service valves B and A.
10. Securely tighten caps of service valves.

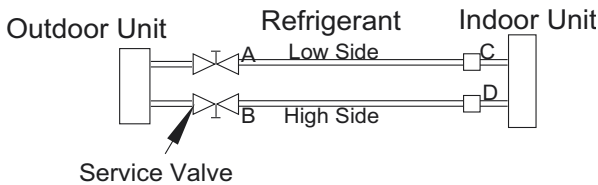

Fig. 18 – Service Valve

A07360

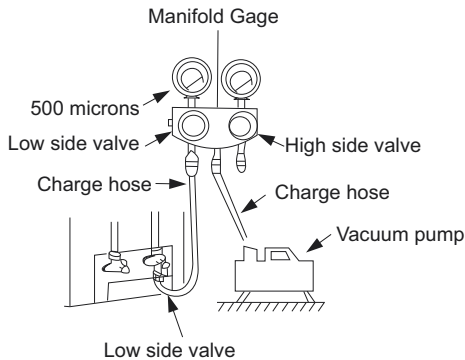

Fig. 19 – Manifold

A07361

Deep Vacuum Method

The deep vacuum method requires a vacuum pump capable of pulling a vacuum of 500 microns and a vacuum gage capable of accurately measuring this vacuum depth. The deep vacuum method is the most positive way of assuring a system is free of air and liquid water. (See Fig. 20)

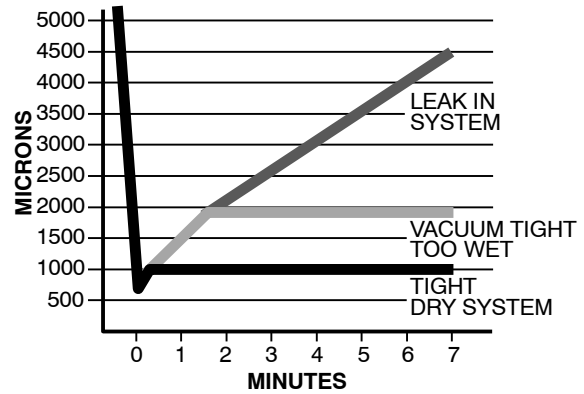

Fig. 20 – Deep Vacuum Graph

A95424

Triple Evacuation Method

The triple evacuation method should only be used when vacuum pump is only capable of pumping down to 28 in. of mercury vacuum and system does not contain any liquid water.

Refer to Fig. 21 and proceed as follows:

1. Pump system down to 28 in. of mercury and allow pump to continue operating for an additional 15 minutes.
2. Close service valves and shut off vacuum pump.
3. Connect a nitrogen cylinder and regulator to system and open until system pressure is 2 psig.
4. Close service valve and allow system to stand for 1 hr. During this time, dry nitrogen will be able to diffuse throughout the system absorbing moisture.
5. Repeat this procedure as indicated in Fig. 21. System will then be free of any contaminants and water vapor.

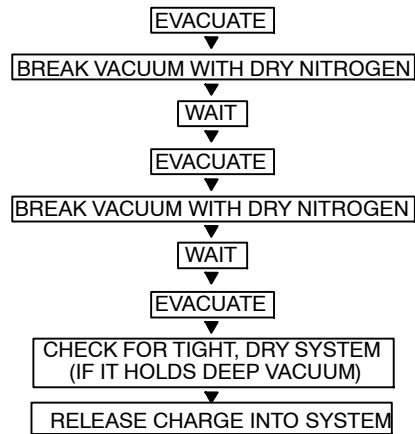

Fig. 21 – Triple Evacuation Method

A95425

Final Tubing Check

IMPORTANT: Check to be certain factory tubing on both indoor and outdoor unit has not shifted during shipment. Ensure tubes are not rubbing against each other or any sheet metal. Pay close attention to feeder tubes, making sure wire ties on feeder tubes are secure and tight.

CONTROL SYSTEM

The 40MVC/MVQ unit is equipped with a microprocessor control to perform two functions:

1. Provide safety for the system
2. Control the system and provide optimum levels of comfort and efficiency

The main microprocessor is located on the control board of the fan coil unit (outdoor units have a microprocessor too) with thermistors located in the fan coil air inlet and on the indoor coil. Heat pump units have a thermistor on the outdoor coil. These thermistors monitor the system operation to maintain the unit within acceptable parameters and control the operating mode.

SYSTEM SAFETIES

Safety	Cooling Only				Heat Pump			
	9K	012K	018K	024K	09K	012K	018K	024K
3 Min Time Delay	X	X	X	X	X	X	X	X
Over Current Protection On Compressor	X	X	X	X	X	X	X	X
Indoor Coil Freeze Protection	X	X	X	X	X	X	X	X
Condenser High Temperature Protection					X	X	X	X
Indoor Evaporator High Temperature					X	X	X	X

3 MINUTE TIME DELAY

In order to protect the compressor, there is a 3 minute delay on break even if the control is calling for heating or cooling.

COMPRESSOR OVERCURRENT PROTECTION

Overcurrent protection can result due to any of the following:

- The ambient temperature is to high
- Locked rotor on the compressor
- Blockage in refrigeration circuit (cap tubes, for example)
- Outdoor air is blocked or restricted

The compressor current is monitored continuously and protection is provided as shown below:

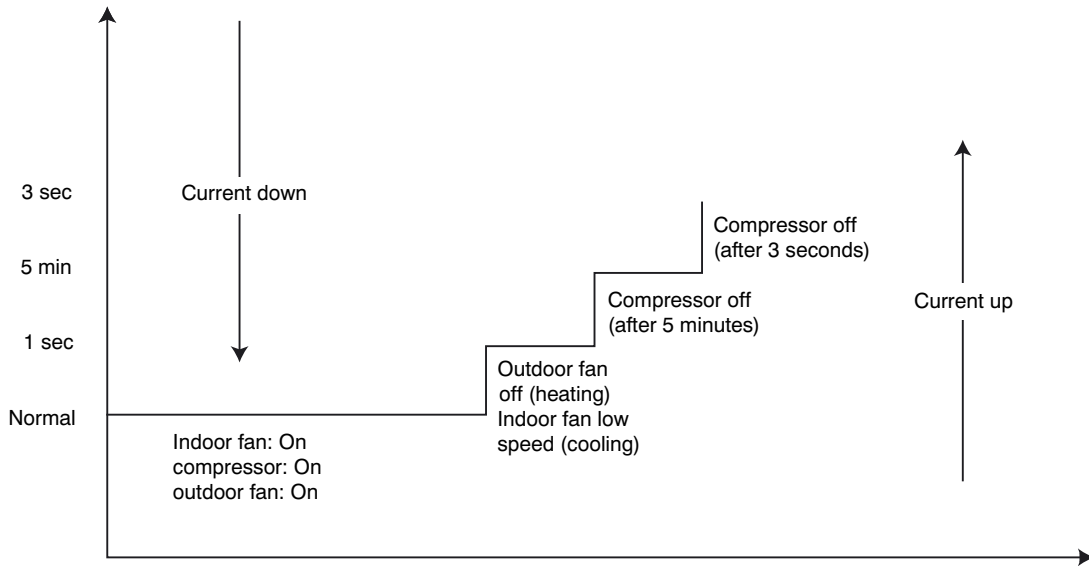

Fig. 22 – Compressor Overcurrent Protection

A08117

If the compressor is stopped 4 times at the 5 minute limit or 1 time at the 3 second limit, the system will be locked off and the main power will have to be reset before the system can be restarted.

Time Limit	Compressor Current				
	38MVC(Q)009-1	38MVC(Q)012-1	38MVC(Q)012-3	38MVC(Q)018-3	38MVC(Q)024-3
3 SEC	14 A	18 A	11 A	14 A	23 A
5 MIN	12 A	16A	9 A	12 A	21 A
1 SEC	10.5 A	14 A	7 A	11 A	18 A
NORMAL	9 A	12.5 A	6 A	10 A	16 A

38/40MVC, MVQ

Indoor Coil Freeze Protection

The indoor coil can freeze due to any of the following:

- Low system charge
- Reduced indoor airflow
- Restricted refrigerant flow
- Low ambient temperature (outdoor)
- Low load (indoor)

In cooling mode, the thermistor located on a return bend of the indoor coil monitors the coil temperature continuously. Any time the coil temperature drops below the TE5 limit for five consecutive minutes, the compressor and outdoor fan will be switched off until the coil temperature rises above the TE6 as shown below:

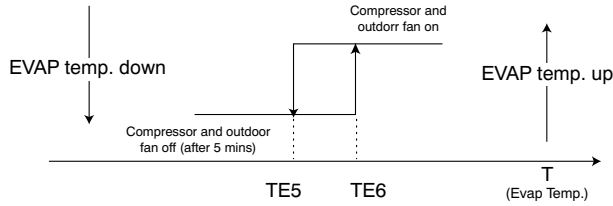

A08118

Fig. 23 – Indoor Coil Freeze Protection

Parameter	Coil Temperature °F (°C)			
	40MVC(Q) 009-1	40MVC(Q) 012-1	40MVC(Q) 018-3	40MVC(Q) 024-3
TE5	39 (4)	41 (5)	36 (2)	36 (2)
TE6	50 (10)	54 (12)	54 (12)	54 (12)

Condenser High Temperature Protection

Condenser high temperature can occur due to any of the following conditions:

- High outdoor ambient
- Outdoor fan blocked
- Outdoor coil blocked

The outdoor coil thermistor on a heat pump unit continuously monitors the temperature of the outdoor coil. Anytime the coil temperature exceeds the TE10 limit, the compressor is switched off and the outdoor fan continues running to reduce the coil temperature. When the coil temperature drops below the TE11 limit, the compressor is switched back on as shown below:

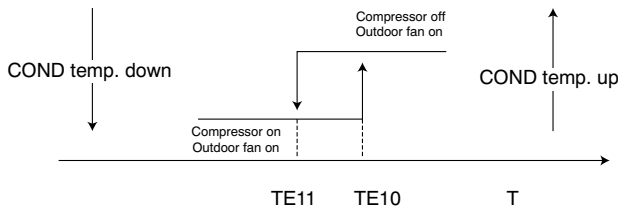

A08119

Fig. 24 – Condenser High Temp Protection

Parameter	Condenser Temp. °F (°C)	
	38MVQ018-3	38MVQ024-3
TE10	149 (63)	158 (70)
TE11	131 (55)	149 (65)

Indoor High Temperature Protection

High indoor coil temperature (in heating mode) can occur due to any of the following:

- High outdoor ambient temperature
- Indoor fan blocked
- Indoor coil blocked (including dirty filters)

The indoor coil thermistor on a heat pump unit continuously monitors the temperature of the indoor coil during heating operation. Anytime the coil temperature exceeds the TE8 limit, the outdoor fan is switched off. If the coil temperature continues to climb and exceeds the TE7 limit, the compressor is switched off. When the coil temperature drops below the TE9 limit, the compressor and outdoor fan are switched back on as shown below:

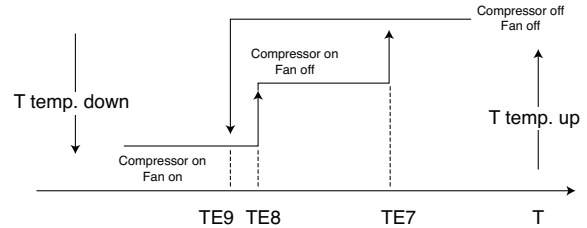

A08120

Fig. 25 – Indoor High Temperature Protection

Parameter	Condenser Coil Temp. °F (°C)			
	40MVQ 009-1	40MVQ 012-1	40MVQ 018-3	40MVQ 024-3
TE7	140 (60)	140 (60)	145 (63)	145 (63)
TE8	129 (54)	129 (54)	129 (54)	129 (54)
TE9	118 (48)	118 (48)	122 (50)	122 (50)

SEQUENCE OF OPERATION

Interface

A wireless remote control, supplied with the unit, is the interface between the fan coil and the user. The wireless remote control has the following characteristics:

- Capable of displaying °C and °F with °C being the default setting. To change the default setting, refer to the Owner's Manual or push the recessed F/C button once using a paper clip or similar object*.
- The remote control setpoint range is from 62°F (17°C) to 88°F (30°C) in increments of 2°F (1°C).
- There is a dedicated cooling only and heat pump remote control.
- The wireless remote control has an operating range of 25 ft. (7.62 m).
- The same remote control can be used to control more than one unit.
- If the remote control is lost, damaged, or the batteries are exhausted, the system can be operated by using the manual button (forced Auto) located under the front panel.

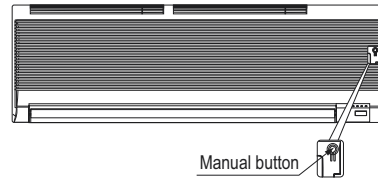

A07364

Fig. 26 – Manual Button Location on Unit

* On units produced during week 12 (2008) and later. Units produced before week 12 have dedicated °C or °F controls.

MODES OF OPERATION

The units have 5 main operating modes:

1. Fan Only
2. Cooling
3. Heating (heat pumps only)
4. Auto
5. Dehumidification (Dry)

The units have 2 other modes (manual operation) that are operated in unique situations:

1. Auto Forced Mode (Emergency)
2. Test Mode

Fan Mode Only

In this mode, the system circulates the room air without changing the room air temperature.

Cooling Mode

In this mode, the system cools and dries the room air with the fan running continuously, either at a selected fan speed or Auto fan speed. The fan runs even when the compressor cycles off. This feature enhances room comfort and efficiency of the system.

When the unit is operating in cooling, two sub modes can also be selected:

1. Sleep Mode is an energy saving feature that changes the set point automatically.
2. Turbo Mode is a comfort feature on the 9k and 12k units where the set point is reached quickly by having the fan run on high speed regardless of the speed that has been selected.

Compressor and Outdoor Fan Operation

The compressor and outdoor fan motor cycle on and off based on the conditions of the set point and the room temperature as shown below. There is no minimum run time.

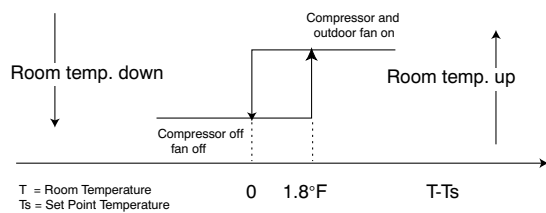

A08106

Fig. 27 – Compressor and Outdoor Fan - Cooling Mode

Indoor Fan Operation

When in cooling mode, the fan runs continuously either at the chosen set speed, or in Auto mode, where the speed is determined by the microprocessor based on the difference between the room temperature and the temperature set point as shown below:

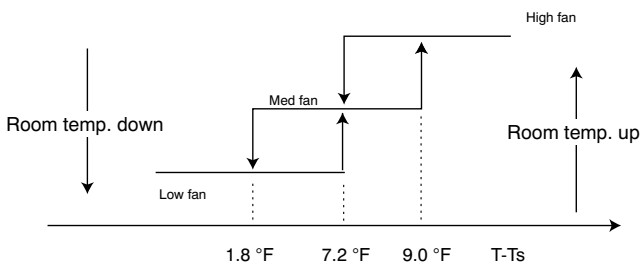

A08107

Fig. 28 – Auto Fan - Cooling Mode

Sleep Mode

When in cooling mode, additional energy savings can be realized by selecting the Sleep setting. When the Sleep setting is selected, the temperature set point is adjusted automatically as shown below:

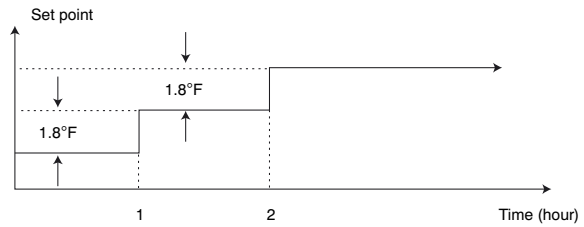

A08108

Fig. 29 – Sleep Mode

The unit will shut off 7 hours after the Sleep Mode is selected.

Turbo Mode

When in cooling mode, selecting Turbo will allow the indoor unit to satisfy the temperature set point as quickly as possible. In Turbo Mode, the indoor fan will shift to high speed and either run continuously for 20 minutes or until the user pushes the Turbo button again, at which point the fan speed will return to the original setting.

Heating Mode

In this mode, the system heats the room air with the indoor fan running at either the selected speed or on Auto. As in the cooling mode, the indoor fan will run continuously unless interrupted by the cold blow algorithm. This algorithm will not allow the fan to run if the indoor coil temperature drops below a preset value.

The sleep function can be selected while the unit is running in the Heating Mode. Defrost is controlled by the on-board microprocessor.

Compressor and Fan Operation

The compressor and outdoor fan cycle on and off based on the actual room temperature versus the set point as shown below. When the compressor starts, it will run continuously for 7 minutes even if the set point condition is satisfied.

The 4-way valve is energized in heating and will stay energized for 2 minutes after the mode is changed into a non-heating mode.

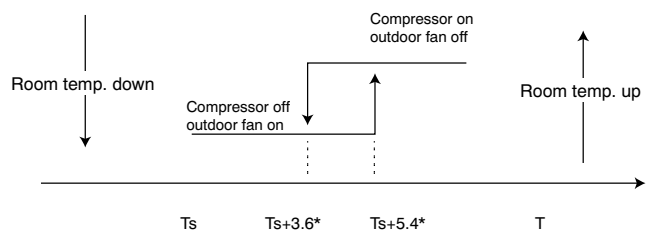

* For 9k & 12k Units Only. For 18k and 24k units, numbers will be 5.4 and 7.2 respectively.

A08109

Fig. 30 – Compressor and Outdoor Fan - Heating Mode

Auto Fan

When the fan speed is set to Auto, the fan will run at either the medium or low speed based on the difference between the room temperature and the set point temperature as shown below:

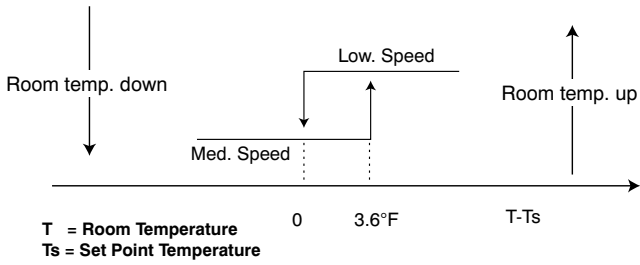

Fig. 31 – Auto Fan - Heating Mode

Manual Indoor Fan

The indoor fan will run continuously in heating at the set fan speed (even if the compressor cycles off) unless the indoor coil temperature begins to drop. When the coil temperature drops to the TE3 limit, the 18k and 24k unit indoor fan switches to low speed. On the 9k and 12k unit the indoor fan switches to ultra low speed. When the coil temperature drops to the TE4 limit, the indoor fan on all systems shuts off to prevent cold blow as shown below. The cold blow algorithm also applies to the auto fan setting.

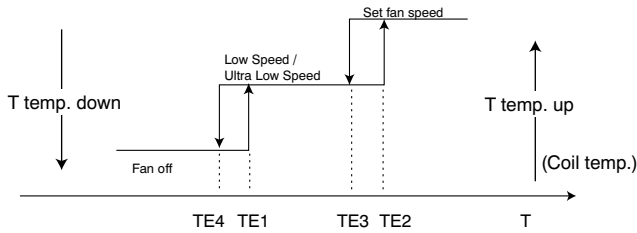

Fig. 32 – Manual Indoor Fan - Heating Mode

Parameter	Indoor Coil Temperature ° F (° C)			
	40MVQ 009-1	40MVQ 012-1	40MVQ 018-3	40MVQ 024-3
TE1	88 (31)	88 (31)	77 (25)	82 (28)
TE2	93 (34)	91 (33)	90 (32)	93 (34)
TE3	86 (30)	81 (27)	86 (30)	90 (32)
TE4	72 (22)	68 (20)	68 (20)	75 (24)

Sleep Mode

When in heating mode additional energy savings can be realized by selecting the Sleep setting. When the Sleep setting is selected, the temperature set point is adjusted automatically as shown below:

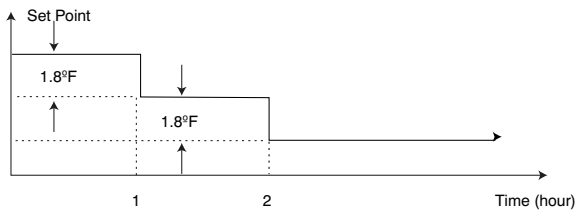

Fig. 33 – Sleep Mode - Heating

The unit will shut off 7 hours after the Sleep mode is selected.

Defrost

Defrost on heat pump units is controlled by the microprocessor and is initiated if either of the following conditions occur:

1. The outdoor coil temperature is lower than 32°F (0°C) for more than 40 minutes and during that period, the coil temperature is continuously lower than 26.6°F (-3°C) for 3 minutes.
2. If the first condition does not occur within 90 minutes of termination of the last defrost cycle.

The defrost cycle will terminate 10 minutes after initiation or when the coil temperature reaches 68°F (20°C). At the end of the Defrost cycle the timer resets automatically.

The cycles of defrost algorithm are shown below:

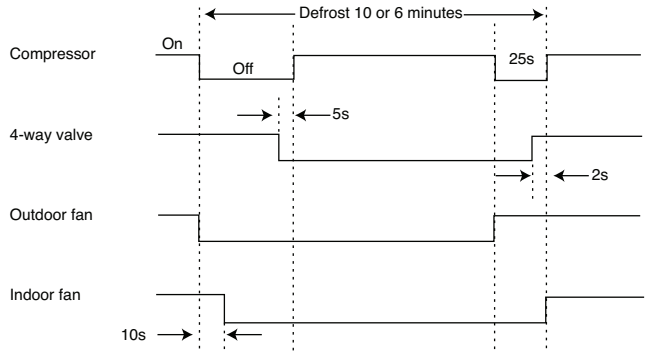

Fig. 34 – Defrost Cycle

Auto Mode

When the Auto setting is selected, the microprocessor looks at the difference between the room temperature (T) and the set point (TS). The algorithm determines which mode the unit will run in as shown below:

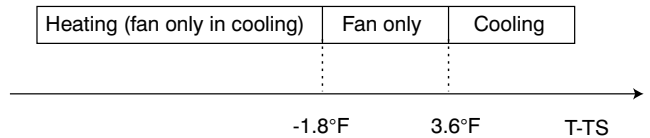

Fig. 35 – Auto Mode

When the unit shifts modes, it will remain in that mode for at least 15 minutes while the algorithm ignores the difference between T and TS. This ensures that the unit cannot change modes too frequently.

38/40MVQ, MVQ

Dry (Dehumidification) Mode

When more humidity control is desired, the Dry setting can be selected. Lower humidity is achieved when the microprocessor adjusts the indoor fan speed and compressor cycling by comparing the room temperature (T) and the set point temperature (TS).

There are two different control algorithms:

Size 9k and 12 k units:

$T = TS + 3.6$ - the compressor will run for 6 minutes and the indoor fan will run at low speed. The compressor will be off for 4 minutes and the indoor fan will run in ultra low speed.

$TS = T < TS + 3.6$ - The compressor will run for 5 minutes and the indoor fan will run at low speed. The compressor will be off for 5 minutes and the indoor fan will run in ultra low speed.

$T < TS$ - The compressor will run for 4 minutes and the indoor fan will run at low speed. The compressor will be off for 6 minutes and the indoor fan will run in ultra low speed.

Size 18k and 24k units:

These units do not have ultra low speed. When set for dehumidification, the indoor fan runs at low speed and the compressor cycles based on the difference between T and TS.

Manual Operation

The unit can be set for Forced Auto or Forced Cooling manually by pushing the Manual button once or twice as shown below:

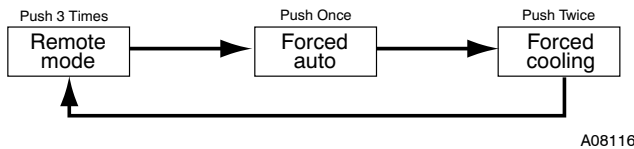

Fig. 36 – Manual Operation

Forced Auto (Emergency Operation)

Forced Auto option allows operation of the unit if the remote control is lost or the batteries have expired. When the system is in Forced Auto, it will run with a default set point of 75.2°F. While in Forced Auto, the system will respond to signals from the remote control.

Forced Cooling Operation

This option is used for diagnostic purposes. The system is forced to run in cooling for 30 minutes.

After 30 minutes, the 9k and 12k systems will switch to Dry mode with a default set point of 75.2°F. The 18k and 24k systems will switch to Forced Auto mode. When the system is in Forced Cooling mode, it will not respond to signals from the remote control. The only way to exit the Forced Cooling mode is to push the manual button once to switch the system to remote control mode.

TROUBLESHOOTING

This section provides the required flow charts to troubleshoot problems that may arise.

NOTE: Information required in the diagnoses can be found either on the wiring diagrams or in the appendix.

Required Tools:

The following tools are needed when diagnosing the units:

- Digital multimeter
- Screw drivers (Phillips and straight head)
- Needle-nose pliers

Recommended Steps

1. Refer to the diagnostic hierarchy chart below and determine the problem at hand.
2. Go to the chart listed in the diagnostic hierarchy and follow the steps in the chart for the selected problem.

DIAGNOSTIC HIERARCHY

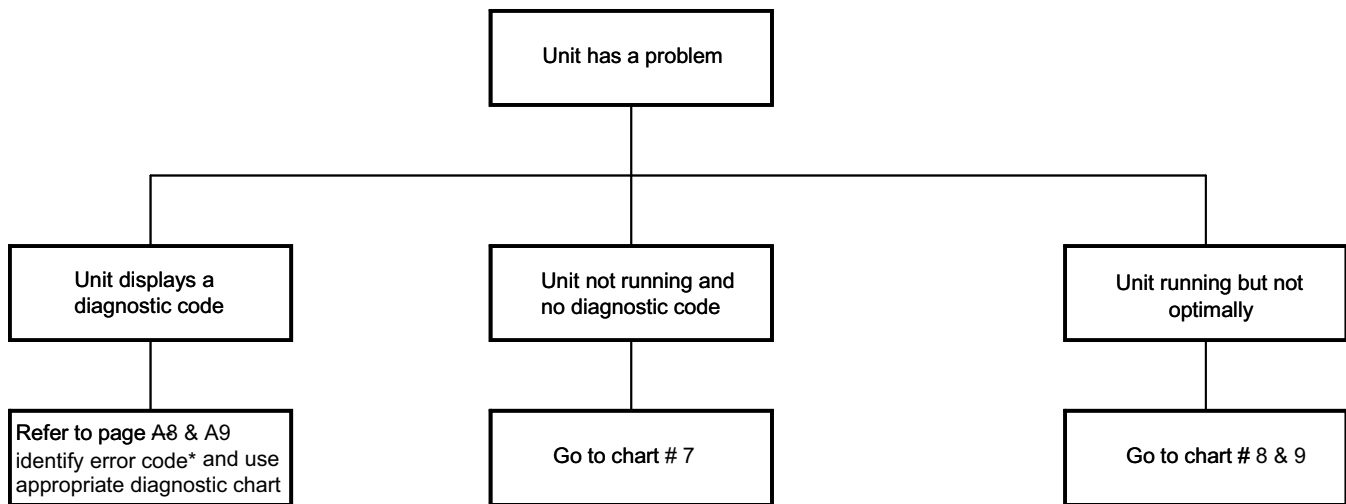

* For EEROM error, replace the indoor microprocessor board

For the ease of service, the systems are equipped with diagnostic code display LED's on both the indoor and outdoor units. The outdoor diagnostic display is an LED on the outdoor unit board and is limited to very few errors. However, it is useful in identifying special error codes like a failure of the outdoor coil sensor on heat pumps. The indoor diagnostic display is a combination of flashing LED's on the display panel on the front of the unit. If possible always check the diagnostic codes displayed on the indoor unit first.

The diagnostic codes for the indoor and outdoor units are listed in appendix A8 and A9.

Problems may occur that are not covered by a diagnostic code, but are covered by the diagnostic flow charts starting with the diagnostic hierarchy. These problems will be typical air conditioning mechanical or electrical issues that can be corrected using standard air conditioning repair techniques.

A08165

For problems requiring measurements at the control boards please note the following:

1. Always disconnect the main power.
2. When possible check the outdoor board first.
3. Start by removing the outdoor unit top cover.
4. Reconnect the main power
5. Probe the outdoor board inputs and outputs with a digital multi-meter referring to the wiring diagrams and input/output charts found in the appendix.
6. Connect the red probe to hot signal and the black probe to the ground or negative.
7. Note that some of the DC voltage signals are pulse will give continuously variable readings.
8. If it is necessary to check the indoor unit board you must start by disconnecting the main power.
9. Next remove the front cover of the unit and then control box cover.
10. Carefully remove the indoor board from the control box, place it face up on a plastic surface (not metal).
11. Reconnect the main power and repeat steps 5,6, and 7.
12. Disconnect main power before reinstalling board to avoid shock hazard and board damage.

CHART 1 - INDOOR FAN SPEED OUT OF CONTROL

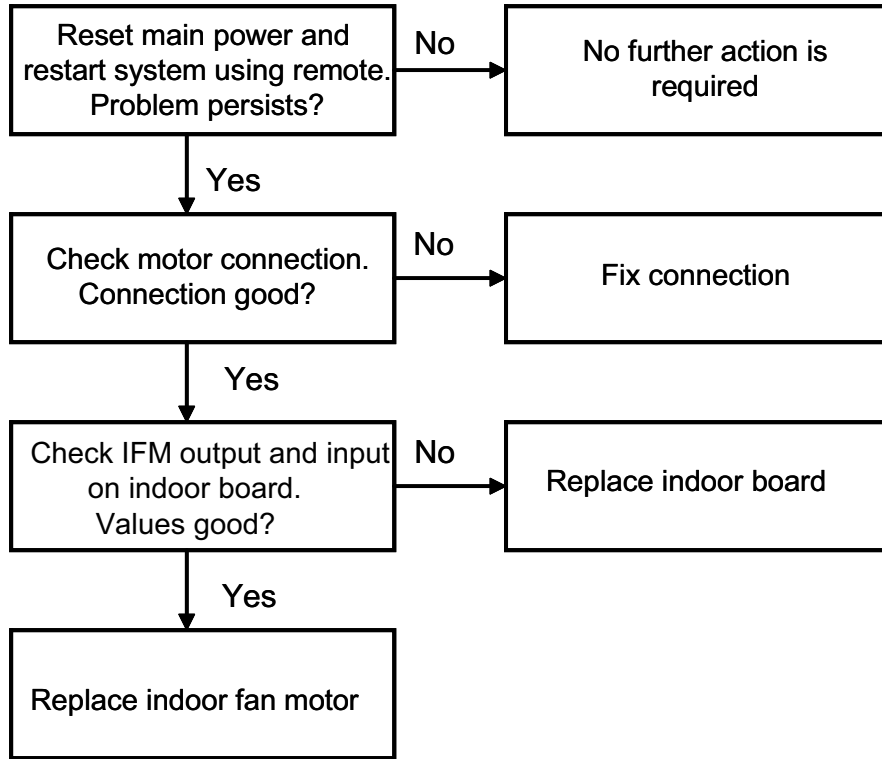

38/40MVC, MVQ

A08166

CHART 2 - TEMPERATURE SENSOR

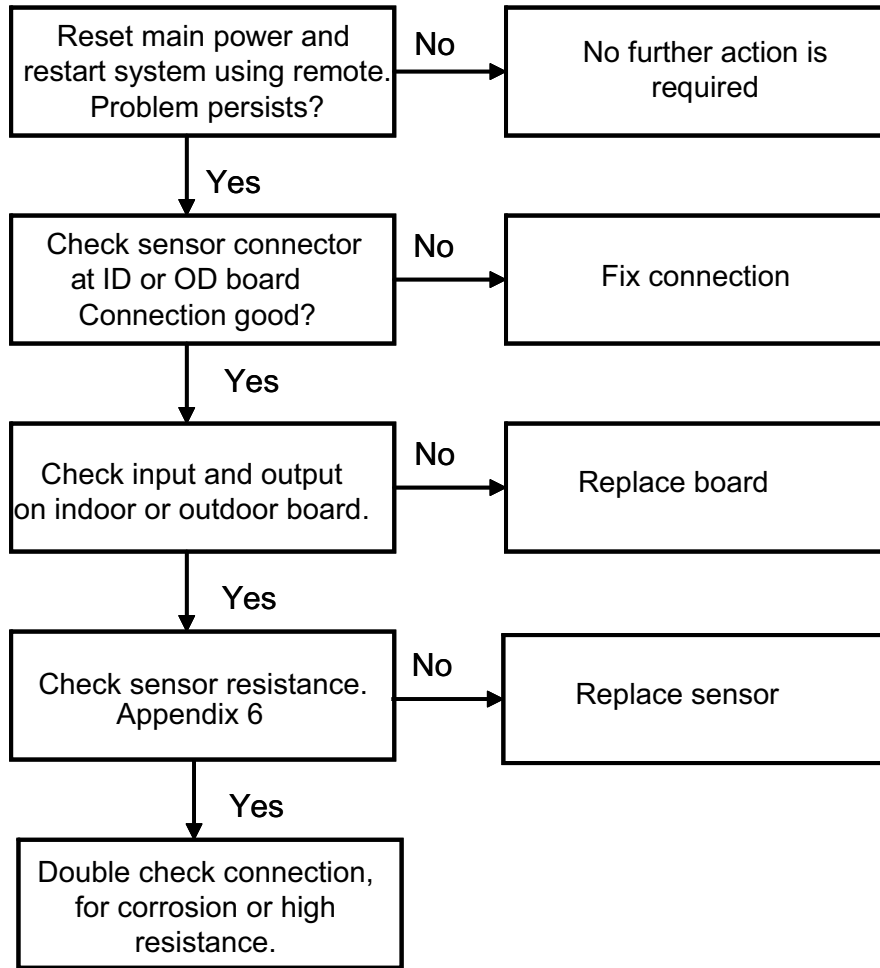

38/40MVC, MVQ

A08167

CHART 3 - COMPRESSOR OVERCURRENT PROTECTION

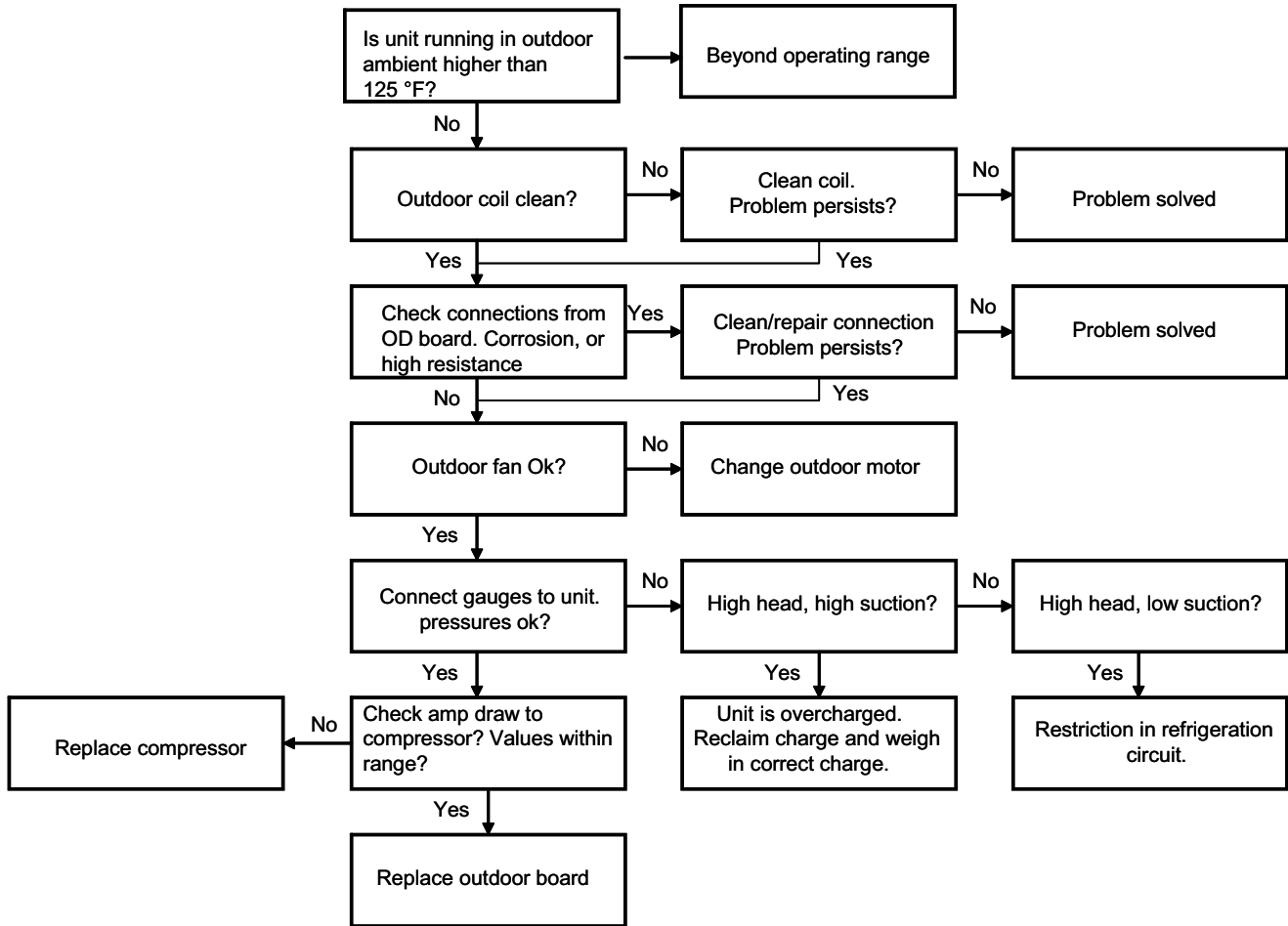

38/40MVC, MVQ

A08168

CHART 4 - INDOOR UNIT COMMUNICATION ERROR SIZE 9K AND 12K

38/40MVC, MVQ

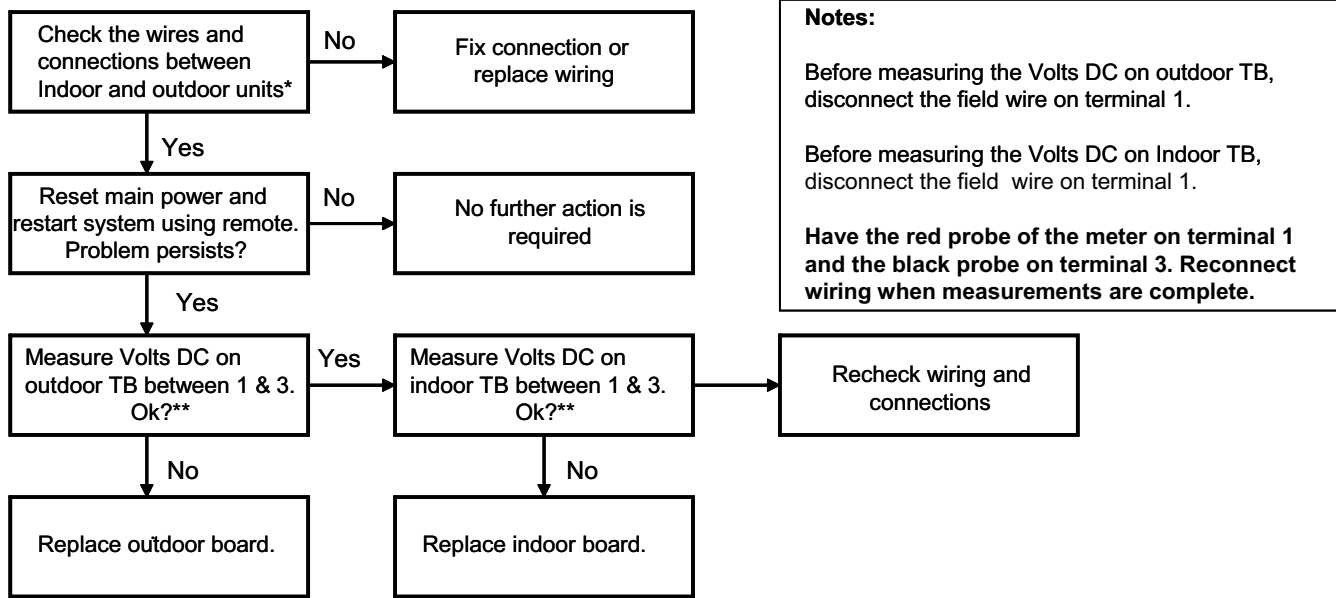

Notes:

Before measuring the Volts DC on outdoor TB, disconnect the field wire on terminal 1.

Before measuring the Volts DC on Indoor TB, disconnect the field wire on terminal 1.

Have the red probe of the meter on terminal 1 and the black probe on terminal 3. Reconnect wiring when measurements are complete.

* Make sure wires are connected per connection diagrams. Failing to do that will result in a communication error.

** There is a 2 to 3 minute window to take the measurement before the diagnostic light is on again.

CHART 5 - OUTDOOR UNIT PROTECTS

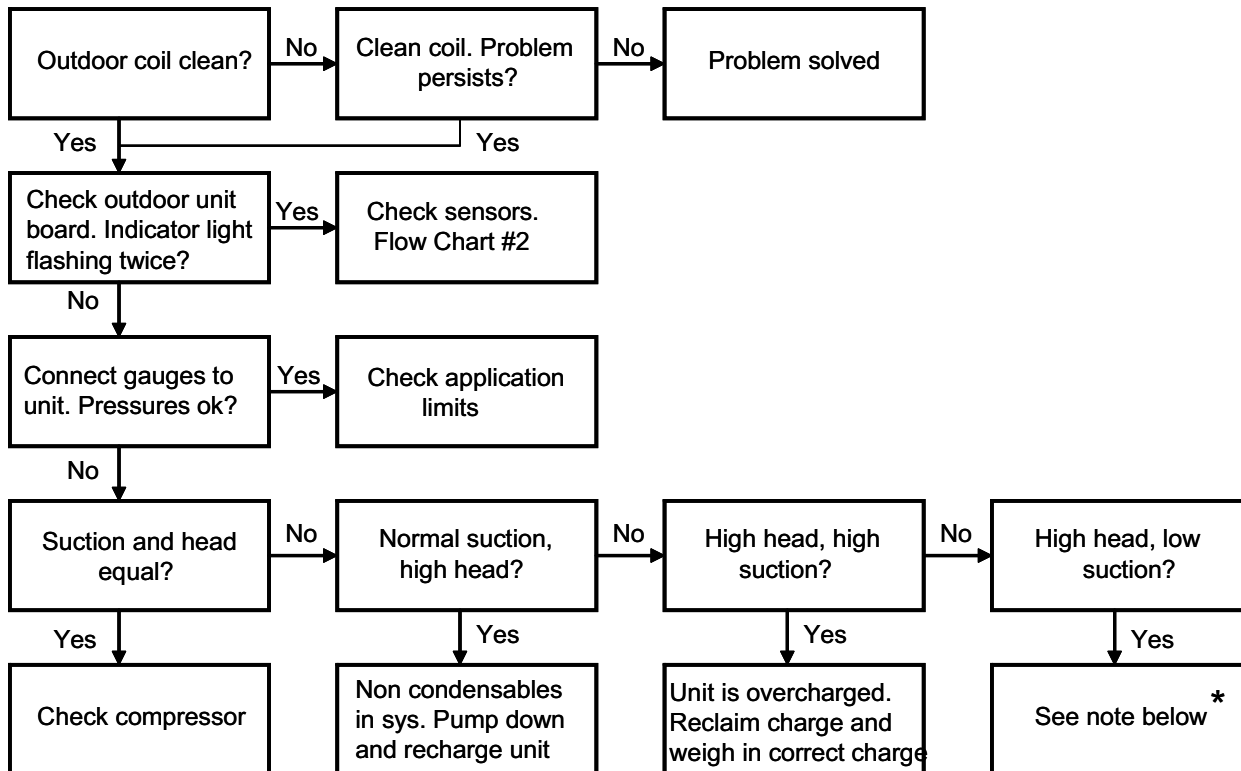

* Restriction in system. Check capillary tube, check for moisture, and check for damage to liquid line between indoor and outdoor units.

A08182

CHART 6 - INDOOR UNIT COMMUNICATION ERROR SIZE 18K AND 24K

38/40MVC, MVQ

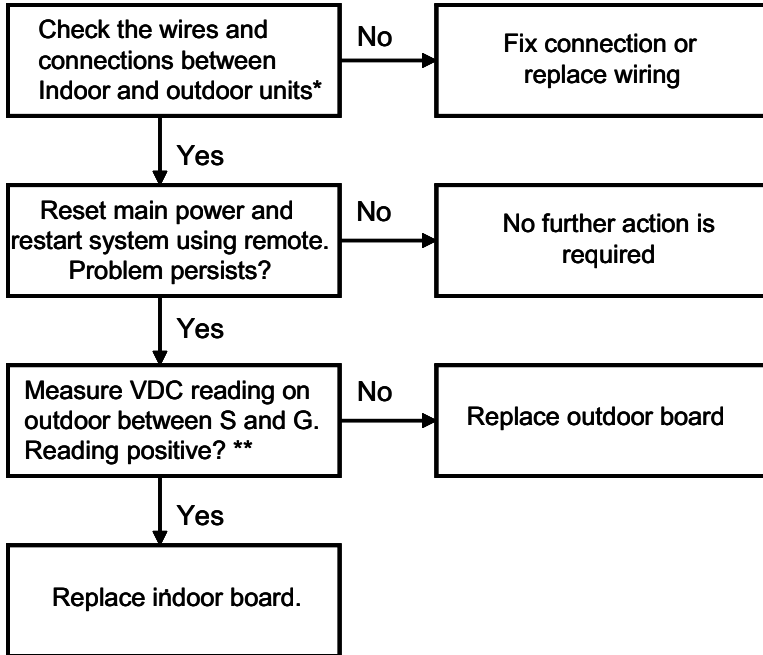

Notes:

When unit is operating normally and a DC voltage reading is taken between the S and G terminal on the outdoor unit (or indoor unit) positive and negative readings will fluctuate between 0 and 24V DC.

If indoor board is bad, only a positive readings will be registered between terminals S and G on the outdoor unit. The reverse will apply if outdoor board is bad (only negative readings will register).

Above data is obtained by having the red probe of the meter on the S terminal and the black probe on the G terminal.

* Make sure wires are connected per connection diagrams i.e. L1 to L1 and L2 to L2. Failing to do that will result in a communication error.

** There is a 2 to 3 minute window to take measurements before the diagnostic light is on again.

CHART 7 - UNIT NOT RUNNING, NO DIAGNOSTIC CODE

38/40MVC, MVQ

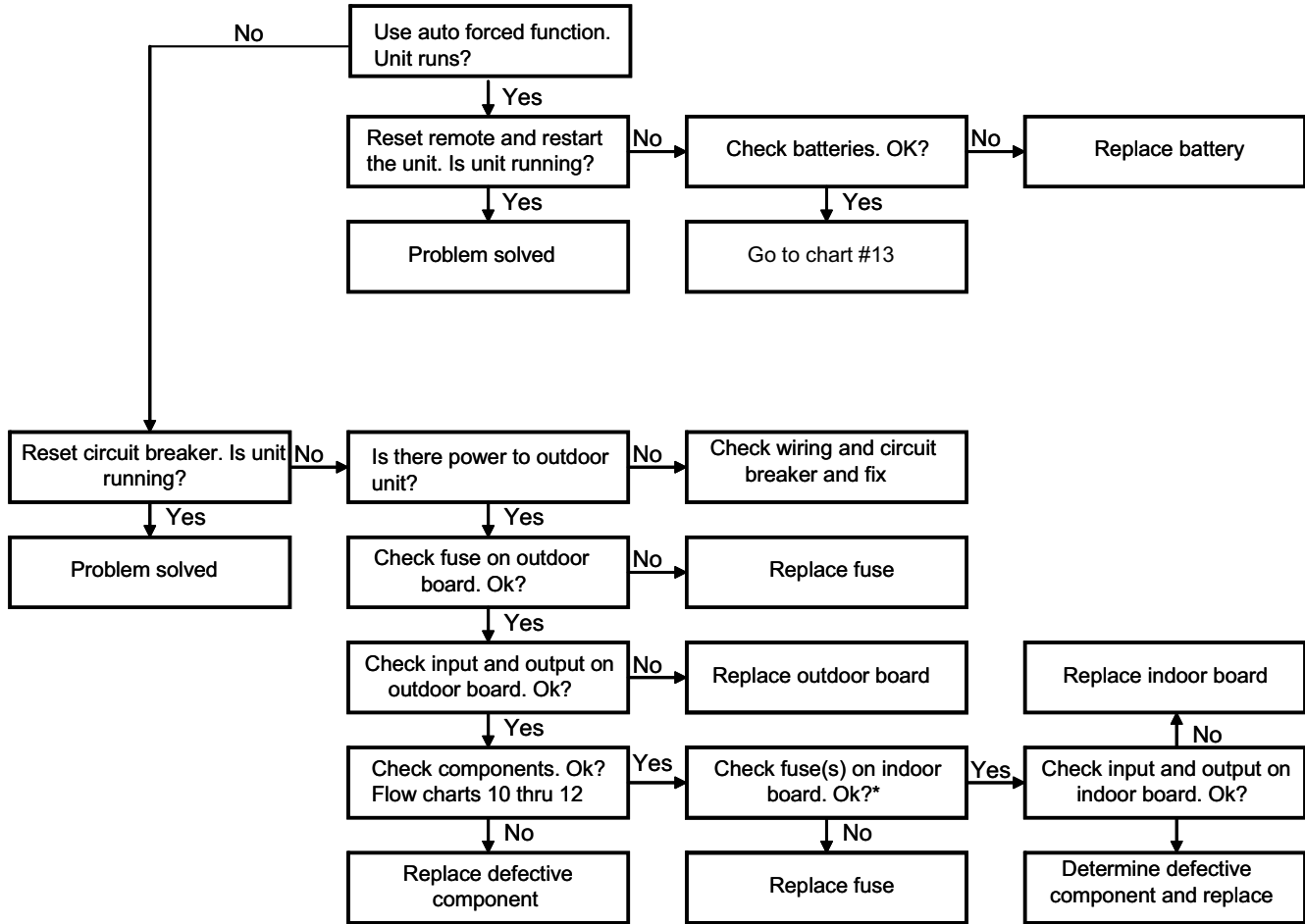

* For sizes 18 and 24 K units only. For sizes 9 and 12K units proceed to check inputs and outputs on indoor boards.

A08169

CHART 8 - UNIT NOT RUNNING OPTIMALLY

38/40MVC, MVQ

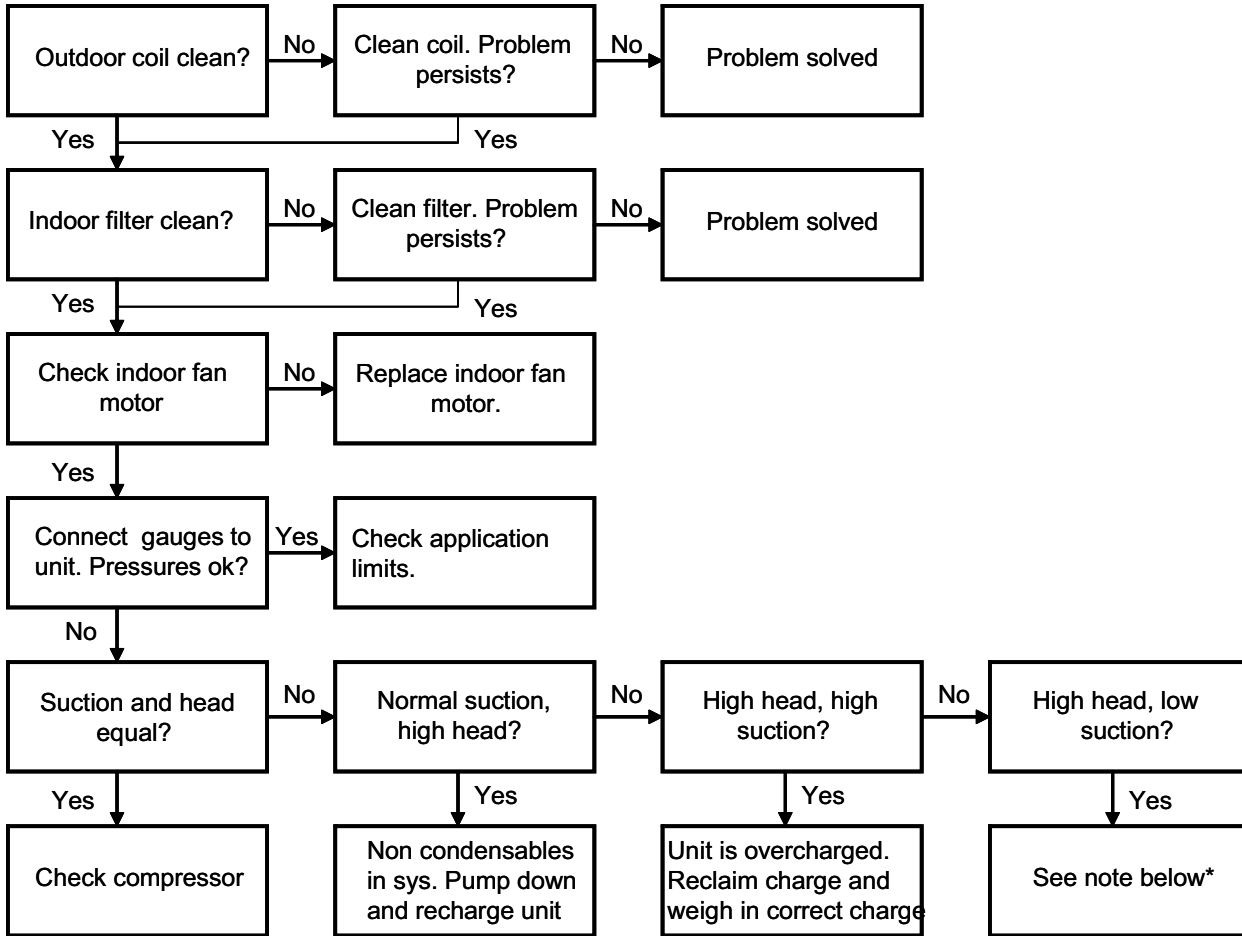

* Restriction in system. Check capillary tube, check for moisture, and check for damage to liquid line between indoor and outdoor units.

A08170

CHART 9 - UNIT NOT RUNNING OPTIMALLY (HP IN HEATING)*

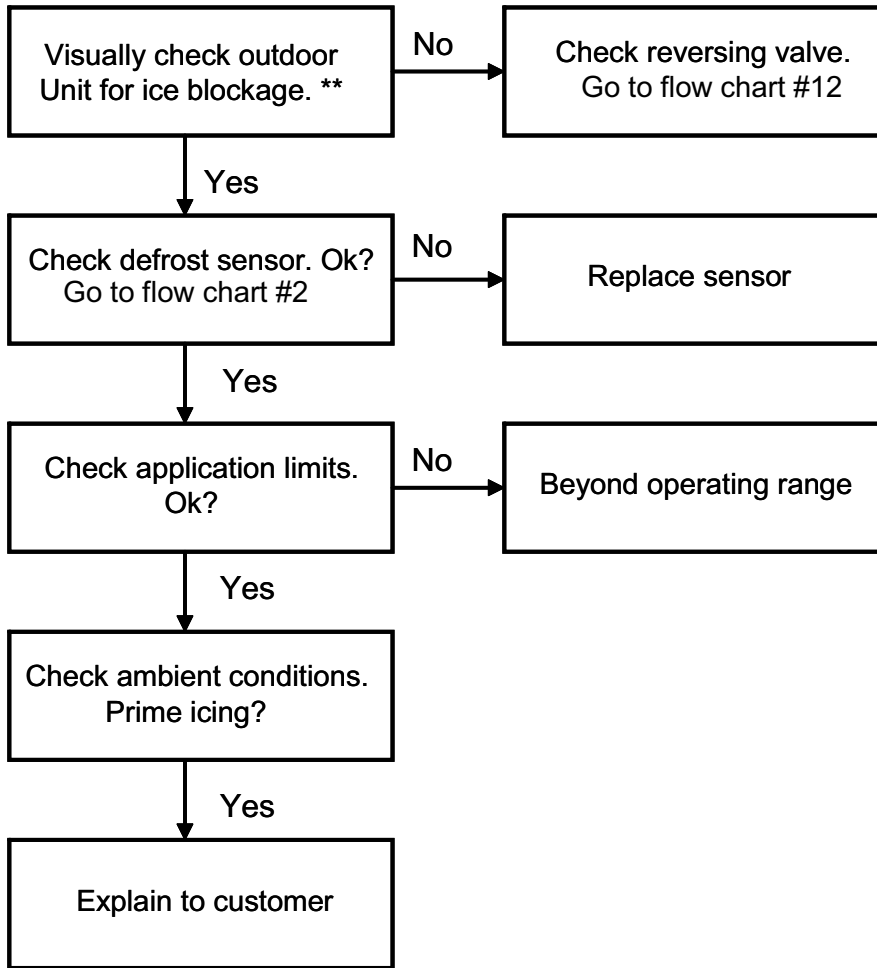

* To supplement flow chart #8

** Check for blockage on outdoor coil and drain pan. Are the holes in drain pans blocked?

A08184

CHART 10 - COMPRESSOR

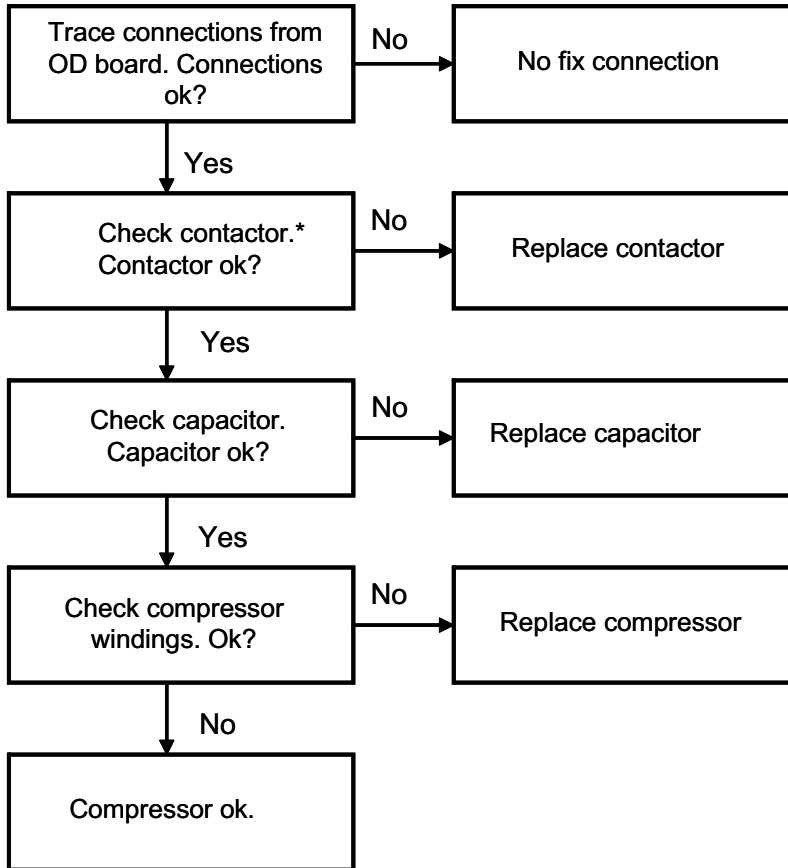

* For size 9 and 12k units contactor is on outdoor board. Check contactor output on outdoor board if not done already. If bad, replace outdoor board.

38/40MVC, MVQ

A08171

CHART 11 - OUTDOOR MOTOR

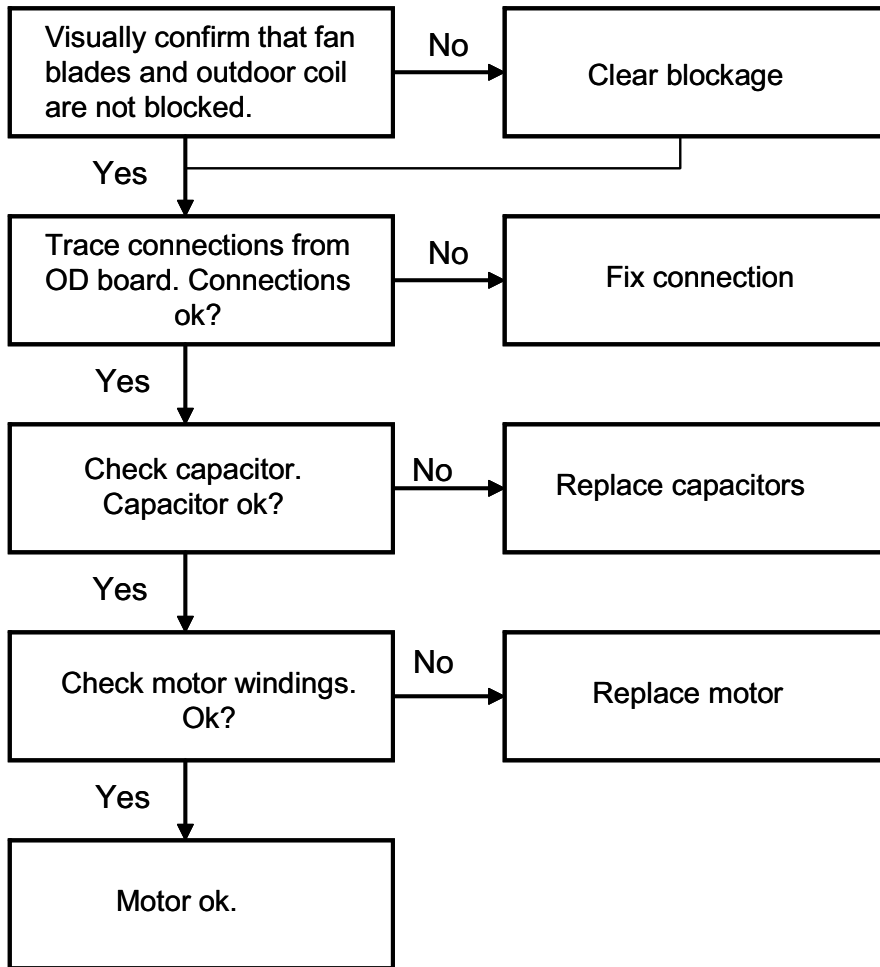

38/40MVC, MVQ

A08172

CHART 12 - REVERSING VALVE

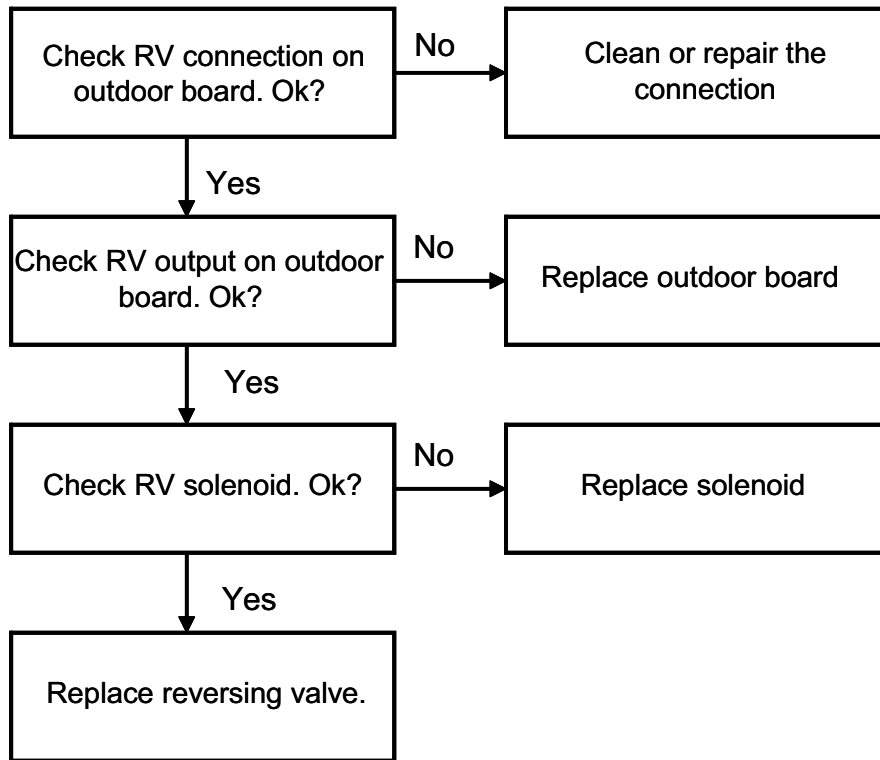
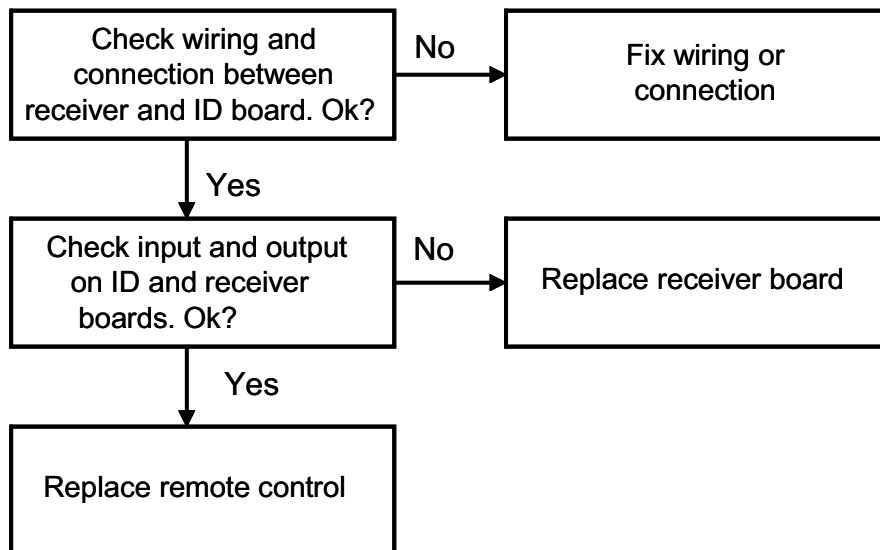

CHART 13 - RECEIVER BOARD



APPENDIX

APPENDIX TABLE OF CONTENTS

DESCRIPTION	NUMBER
Control Boards Input/Output tables for 53MVC009(12)---1	A1
Control Boards Input/Output tables for 53MVQ009(12)---1	A2
Control Boards Input/Output tables for 53MVC012---3	A3
Control Boards Input/Output tables for 53MVQ012---3	A4
Control Boards Input/Output tables for 53MVC018---3	A5
Temperature Sensor Values (Temperature vs. Resistance)	A6
Fuse Chart	A7
Indoor Unit Diagnostic Codes	A8
Outdoor Unit Diagnostic Codes	A9

A1 - 53MVC009---1 / 53MVC012---1

38MVC009---1/38MVC012---1 CONTROL BOARD	
CONNECTOR	INPUT or OUTPUT VALUE
CN2	OUT: (Pin 1: Pulse 0 to 12 Volts DC) (Pin2: 35±2 Volts DC) (Pin 3: GND) (Pin 4: 13±4 Volts DC) all relative to Pin 3
CN3	OUT: Neutral
CN4	IN: Neutral
CN9	OUT: L 115 Volts AC
CN10	IN: L 115 Volts AC
P1	GND
P2	GND
40MVC009---1/40MVC012---1 CONTROL BOARD	
CONNECTOR	INPUT or OUTPUT VALUE
CN1	IN: 0–5 Volt DC
CN2	IN: 0–5 Volt DC
CN3	Pulse drive output: 0–17 Volts DC (Pin 5: GND All other Pins are 0 to 17 Volt DC) All relative to Pin 5)
CN5	Power Output: (Pin 1: GND) (Pin 2: 5 Volts DC) Input: (Pin 3: Pulse 0 to 5 Volts DC) Output:(Pin 4~ Pin 10: Pulse 0 to 5 Volt DC) All relative to Pin 1
CN6	Out: (Pin 1: 35 Volt DC) (Pin 2: Empty) (Pin 3: GND) (Pin 4: 5 Volt DC) (Pin 5: Pulse 0–5 Volt DC) IN: (Pin 6: Pulse 0 to 5 Volt DC) All relative to Pin 3
G1	IN: (Pin 1: Pulse 0 to 12 Volts DC) (Pin2: 35±2 Volts DC) (Pin 3: GND) (Pin 4: 13±4 Volts DC) all relative to Pin 3

38/40MVC, MVQ

A2 - 53MVQ009---1 / 53MVQ012---1

38MVQ009-1/38MVQ012---1 CONTROL BOARD	
CONNECTOR	INPUT or OUTPUT VALUE
CN1	OUT: (Pin 1: GND, Pin 2: 5 Volts DC, Pin 3: Empty) IN: (Pin 4: 0 to 5 Volts DC) All relative to Pin 1
CN2	OUT: (Pin 1: Pulse 0 to 12 Volts DC) (Pin2: 35±2 Volts DC) (Pin 3: GND) (Pin 4: 13±4 Volts DC) all relative to Pin 3
CN3	OUT: Neutral
CN4	IN: Neutral
CN5	OUT: L 115 Volt AC
CN6	OUT: L 115 Volt AC
CN10	IN: L 115 Volt AC
P1	GND
P2	GND
40MVQ009-1/40MVQ012---1 CONTROL BOARD	
CONNECTOR	INPUT or OUTPUT VALUE
CN1	IN: 0–5 Volt DC
CN2	IN: 0–5 Volt DC
CN3	Pulse drive output: 0–17 Volts DC (Pin 5: GND All other Pins are 0 to 17 Volt DC) All relative to Pin 5)
CN5	Power Output: (Pin 1: GND) (Pin 2: 5 Volts DC) Input: (Pin 3: Pulse 0 to 5 Volts DC) Output:(Pin 4~ Pin 10: Pulse 0 to 5 Volt DC) All relative to Pin 1
CN6	Out: (Pin 1: 35 Volt DC) (Pin 2: Empty) (Pin 3: GND) (Pin 4: 5 Volt DC) (Pin 5: Pulse 0–5 Volt DC) IN: (Pin 6: Pulse 0 to 5 Volt DC) All relative to Pin 3
G1	IN: (Pin 1: Pulse 0 to 12 Volts DC) (Pin2: 35±2 Volts DC) (Pin 3: GND) (Pin 4: 13±4 Volts DC) all relative to Pin 3

A3 - 53MVC012---3

38MVC012---3 CONTROL BOARD	
CONNECTOR	INPUT or OUTPUT VALUE
CN2	OUT: (Pin 1: Pulse 0 to 12 Volts DC) (Pin2: 35±2 Volts DC) (Pin 3: GND) (Pin 4: 13±4 Volts DC) all relative to Pin 3
CN3	OUT: L2 208/230 Volt AC
CN4	IN: L2 208/230 Volt AC
CN9	OUT: L1 208/230 Volt AC
CN10	IN: L1 208/230 Volt AC
P1	Ground
P2	Ground
40MVC012---3 CONTROL BOARD	
CONNECTOR	INPUT or OUTPUT VALUE
CN1	IN: 0–5 Volt DC
CN2	IN: 0–5 Volt DC
CN3	Pulse drive output: 0–17 Volts DC (Pin 5: GND All other Pins are 0 to 17 Volt DC) All relative to Pin 5)
CN5	Power Output: (Pin 1: GND) (Pin 2: 5 Volts DC) Input: (Pin 3: Pulse 0 to 5 Volts DC) Output:(Pin 4~ Pin 10: Pulse 0 to 5 Volt DC) All relative to Pin 1
CN6	Out: (Pin 1: 35 Volt DC) (Pin 2: Empty) (Pin 3: GND) (Pin 4: 5 Volt DC) (Pin 5: Pulse 0–5 Volt DC) IN: (Pin 6: Pulse 0 to 5 Volt DC) All relative to Pin 3
G1	IN: (Pin 1: Pulse 0 to 12 Volts DC) (Pin2: 35±2 Volts DC) (Pin 3: GND) (Pin 4: 13±4 Volts DC) all relative to Pin 3

38/40MVC, MVQ

A4 - 53MVQ012---3

38MVQ012---3 CONTROL BOARD	
CONNECTOR	INPUT or OUTPUT VALUE
CN1	OUT: (Pin 1: GND, Pin 2: 5 Volts DC, Pin 3: Empty) IN: (Pin 4: 0 to 5 Volts DC) All relative to Pin 1
CN2	OUT: (Pin 1: Pulse 0 to 12 Volts DC) (Pin2: 35±2 Volts DC) (Pin 3: GND) (Pin 4: 13±4 Volts DC) all relative to Pin 3
CN3	OUT: L2 208/230 Volt AC
CN4	IN: L2 208/230 Volt AC
CN5	OUT: L1 208/230 Volt AC
CN6	OUT: L1 208/230 Volt AC
CN10	IN: L1 208/230 Volt AC
P1	Ground
P2	Ground
40MVQ012---3 CONTROL BOARD	
CONNECTOR	INPUT or OUTPUT VALUE
CN1	IN: 0–5 Volt DC
CN2	IN: 0–5 Volt DC
CN3	Pulse drive output: 0–17 Volts DC (Pin 5: GND All other Pins are 0 to 17 Volt DC) All relative to Pin 5)
CN5	Power Output: (Pin 1: GND) (Pin 2: 5 Volts DC) Input: (Pin 3: Pulse 0 to 5 Volts DC) Output:(Pin 4~ Pin 10: Pulse 0 to 5 Volt DC) All relative to Pin 1
CN6	Out: (Pin 1: 35 Volt DC) (Pin 2: Empty) (Pin 3: GND) (Pin 4: 5 Volt DC) (Pin 5: Pulse 0–5 Volt DC) IN: (Pin 6: Pulse 0 to 5 Volt DC) All relative to Pin 3
G1	IN: (Pin 1: Pulse 0 to 12 Volts DC) (Pin2: 35±2 Volts DC) (Pin 3: GND) (Pin 4: 13±4 Volts DC) all relative to Pin 3

A5 - 53MVC018---3

38/40MVC, MVQ

38MVC018---3 CONTROL BOARD	
CONNECTOR	INPUT or OUTPUT VALUE
CN1	IN: 14.5±5V Volts AC
CN3	Pulse Signal 0 to 24 Volts DC (Relative to ground)
CN4	IN: L1 208/230 Volts AC
CN5	IN: L2 208/230 Volts AC
CN6	OUT: 208/230 Volts AC
CN8	OUT: 208/230 Volts AC
40MVC018---3 CONTROL BOARD	
CONNECTOR	INPUT or OUTPUT VALUE
CN1	IN: 11.0±3 Volts AC (Pin 1 to Pin2); 9.5±2 Volts AC (Pin 3 to Pin 4)
CN2	OUT: IFM Capacitor Terminal 1
CN4	OUT: IFM Capacitor Terminal 2
CN5	OUT: 208/230 Volts AC
CN6	OUT: 208/230 Volts AC (Pin 1 to Pin 2, Pin 1 to Pin 3, Pin 1 to Pin4)
CN7	IN: 0-5 Volt DC (Not including 0V and 5V)
CN8	IN: 0-5 Volt DC (Not including 0V and 5V)
CN9	OUT: (Pin 1: Ground, Pin 2: 5 Volts DC) IN: (Pin 1: Ground, Pin 3: 0 to 5 Volts DC) Pulse relative to Pin 1
CN10	OUT: (Pin 1: Ground, Pin 2 ~ Pin 5: 0 to 5 Volts DC) Pulse relative to Pin 1
CN11	OUT: (Pin 5: Ground, all other Pins are 0 to 17 Volts DC) Pulse relative to Pin 5
CN12	Two way signal, 0 to 24 Volts DC, Pulse relative to Ground
P1	IN: L1 208/230 Volts AC
P2	IN: L2 208/230 Volts AC
INDOOR UNIT DISPLAY BOARD	
CONNECTOR	INPUT or OUTPUT VALUE
CN1	IN: (Pin 1: Ground, Pin 2 ~ 5: 0 to 5 Volts DC) Pulse relative to Pin 1
CN2	IN: (Pin 1: Ground, Pin: 5 Volts DC) OUT: (Pin 3: 0 to 5 Volts DC) Pulse relative to Pin 1

A6 - Characteristics of Temperature Sensor

Temp. ° F/° C	Resistance KΩ	Temp. ° F/° C	Resistance KΩ	Temp. ° F/° C	Resistance KΩ
14/-10	62.2756	62.6/17	14.6181	111.2/44	4.3874
15.8/-9	58.7079	64.4/18	13.918	113/45	4.2126
17.6/-80	56.3694	66.2/19	13.2631	114.8/46	4.0459
19.4/-7	52.2438	68/20	12.6431	116.6/47	3.8867
21.2/-6	49.3161	69.8/21	12.056	118.4/48	3.7348
23/-5	46.5725	71.6/22	11.5	120.2/49	3.5896
24.8/-4	44	73.4/23	10.9731	122/50	3.451
26.6/-3	41.5878	75.2/24	10.4736	123.8/51	3.3185
28.4/-2	39.8239	77/25	10	125.6/52	3.1918
30.2/-1	37.1988	78.8/26	9.5507	127.4/53	3.0707
32/0	35.2024	80.6/27	9.1245	129.2/54	2.959
33.8/1	33.3269	82.4/28	8.7198	131/55	2.8442
35.6/2	31.5635	84.2/29	8.3357	132.8/56	2.7382
37.4/3	29.9058	86/30	7.9708	134.6/57	2.6368
39.2/4	28.3459	87.8/31	7.6241	136.4/58	2.5397
41/5	26.8778	89.6/32	7.2946	138.2/59	2.4468
42.8/6	25.4954	91.4/33	6.9814	140/60	2.3577
44.6/7	24.1932	93.2/34	6.6835	141.8/61	2.2725
46.4/8	22.5662	95/35	6.4002	143.6/62	2.1907
48.2/9	21.8094	96.8/36	6.1306	145.4/63	2.1124
50/10	20.7184	98.6/37	5.8736	147.2/64	2.0373
51.8/11	19.6891	100.4/38	5.6296	149/65	1.9653
53.6/12	18.7177	102.2/39	5.3969	150.8/66	1.8963
55.4/13	17.8005	104/40	5.1752	152.6/67	1.83
57.2/14	16.9341	105.8/41	4.9639	154.4/68	1.7665
59/15	16.1156	107.6/42	4.7625	156.2/69	1.7055
60.8/16	15.3418	109.4/43	4.5705	158/70	1.6469

38/40MVC, MVQ

A7 - Fuse Chart

Unit Size	Fuse Rating (Amps/Volts)		
	Indoor	Outdoor	Outdoor
009	–	3.15A/250V	2A/250V
012	–	3.15A/250V	2A/250V
018	3.15A/250V	3.15A/250V	–
024	3.15A/250V	3.15A/250V	–

The 3.15A fuses protect the board against the indoor or outdoor fan motors.
The 2A fuses protect the board against a Class II circuit board failure.

A8 - Indoor Unit Diagnostic Guides

9K & 12K Units

Operation Lamp	Timer Lamp	Failure Mode	Diagnostic Chart
☆	X	Indoor fan speed has been out of control for over 1 minute	1
☆	On	Indoor room temp. or evaporator sensor is open circuit or short circuited	2
X	☆	Compressor over-current protection has been activated four times	3
On	☆	EPROM error*	–
☆	☆	Indoor unit communication error (Illuminates simultaneously)	4

18K & 24K Units

Operation Lamp	Timer Lamp	Defrosting Lamp	Auto Lamp	Failure Mode	Diagnostic Chart
☆	☆	☆	☆	Over-current protection of the compressor occurs four times	3
X	☆	X	X	Indoor room temp. sensor is open circuit or short circuited	2
☆	X	X	X	Temp. sensor on indoor evaporator is open circuit or short circuited	2
X	X	☆	X	Temp. sensor on outdoor condenser is open circuit or short circuited (not cooling only modes)	2
X	X	☆	☆	Outdoor unit protects (outdoor temp. sensor, phase order, etc.)	5
X	☆	X	☆	EPROM error*	–
X	X	X	☆	Indoor unit communication error	6

☆ = Flashing

X = Off

* = Replace Indoor Board

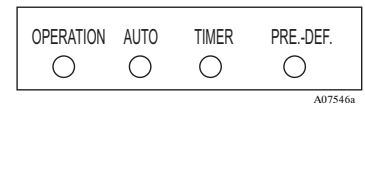
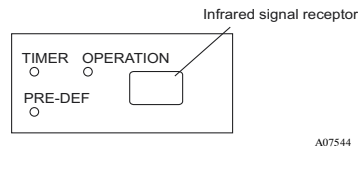
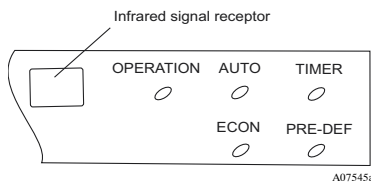

* PRE-DEF light will illuminate when the unit is running in FAN ONLY mode on Cooling Only units.

Fig. 37 – LED Display Panel

A9 - Outdoor Unit Diagnostic Guides

Flashing Times after 2 Second Off	Failure Mode	Diagnostic Chart
5	Communication failure	4 or 6
2	Condenser temperature sensor failure	2
1	Other indoor failure	–

If the unit is operating normally, the LED light on the outdoor board is lit continuously. If there is a failure, the LED light will flash a specific number of times. Refer to the Outdoor Unit Diagnostic table above to determine failure.