

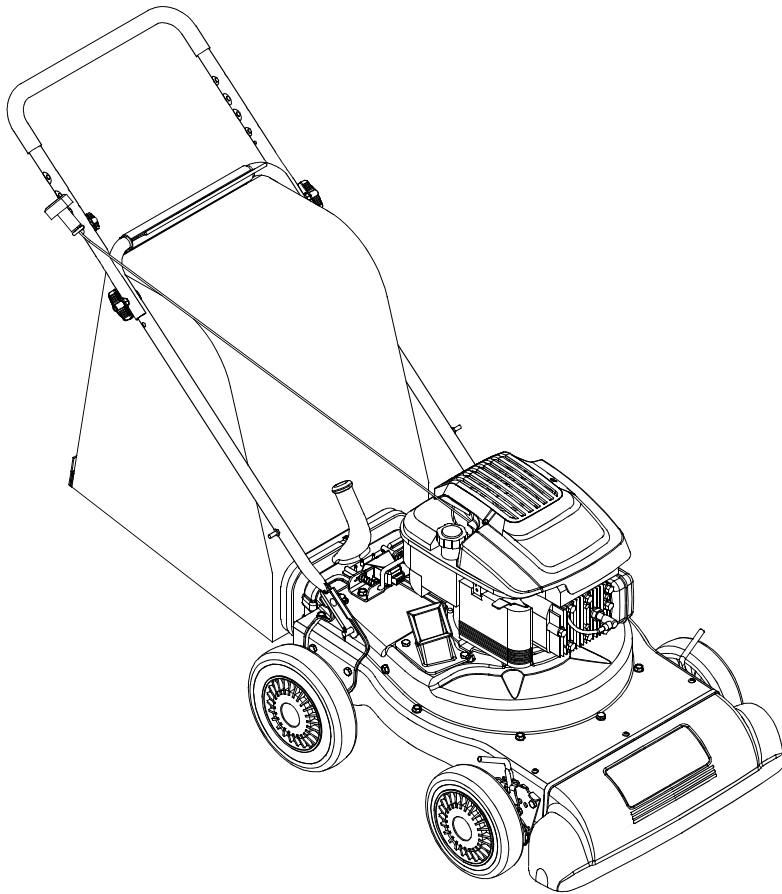

OPERATOR'S MANUAL



**Chipper Shredder
Vacuum
Model Number
24A-020D401**



IMPORTANT: READ SAFETY RULES AND INSTRUCTIONS CAREFULLY

Warning: This unit is equipped with an internal combustion engine and should not be used on or near any unimproved forest-covered, brush-covered or grass-covered land unless the engine's exhaust system is equipped with a spark arrester meeting applicable local or state laws (if any). If a spark arrester is used, it should be maintained in effective working order by the operator. In the State of California the above is required by law (Section 4442 of the California Public Resources Code). Other states may have similar laws. Federal laws apply on federal lands. A spark arrester for the muffler is available through your nearest engine authorized service dealer or contact the service department, P.O. Box 368022 Cleveland, Ohio 44136-9722.

MTD PRODUCTS INC. P.O. BOX 368022 CLEVELAND, OHIO 44136-9722

TABLE OF CONTENTS

Content	Page
Important Safe Operation Practices.....	3
Assembling Your Chipper Shredder Vacuum	5
Know Your Chipper Shredder Vacuum	7
Operating Your Chipper Shredder Vacuum	8
Maintaining Your Chipper Shredder Vacuum.....	9
Troubleshooting.....	12
Parts List.....	14

FINDING MODEL NUMBER

This Operator's Manual is an important part of your new chipper shredder vacuum. It will help you assemble, prepare and maintain the unit for best performance. Please read and understand what it says.



Before you start assembling your new equipment, please locate the model plate on the equipment and copy the information from it in the space provided below. The information on the model plate is very important if you need help from our Customer Support Department or an authorized dealer.

- You can locate the model number by looking down at the rear of the chipper shredder vacuum. A sample model plate is explained below. For future reference, please copy the model number and the serial number of the equipment in the space below.

_____	_____
(Model Number)	(Serial Number)

 **MTD PRODUCTS INC**
CLEVELAND, OHIO 44136

Copy the model number here: _____

Copy the serial number here: _____

CALLING CUSTOMER SUPPORT

If you have difficulty assembling this product or have any questions regarding the controls, operation or maintenance of this unit, please call the Customer Support Department.



Call 1- (330) 220-4MTD (4683) or 1- (800)-800-7310 to reach a Customer Support representative. Please have your unit's model number and serial number ready when you call. See previous section to locate this information. You will be asked to enter the serial number in order to process your call.

For more details about your machine, visit our website at www.yardman.com

SECTION 1: IMPORTANT SAFE OPERATION PRACTICES



WARNING: This symbol points out important safety instructions which, if not followed, could endanger the personal safety and/or property of yourself and others. Read and follow all instructions in this manual before attempting to operate this machine. Failure to comply with these instructions may result in personal injury. When you see this symbol - **heed its warning.**

WARNING: The Engine Exhaust from this product contains chemicals known to the State of California to cause cancer, birth defects or other reproductive harm.

DANGER: This machine was built to be operated according to the rules for safe operation in this manual. As with any type of power equipment, carelessness or error on the part of the operator can result in serious injury. This machine is capable of amputating hands and feet and throwing objects. Failure to observe the following safety instructions could result in serious injury or death.

TRAINING

- Read, understand, and follow all instructions on the machine and in the manual(s) before attempting to assemble and operate. Keep this manual in a safe place for future and regular reference and for ordering replacement parts.
- Be familiar with all controls and their proper operation. Know how to stop the machine and disengage them quickly.
- Never allow children under 16 years old to operate this machine. Children 16 years old and over should read and understand the operation instructions and safety rules in this manual and should be trained and supervised by a parent.
- Never allow adults to operate this machine without proper instruction.
- Keep bystanders, helpers, pets, and children at least 75 feet from the machine while it is in operation. Stop machine if anyone enters the area.
- Never run an engine indoors or in a poorly ventilated area. Engine exhaust contains carbon monoxide, an odorless and deadly gas.
- Do not put hands and feet near rotating parts or in the feeding chambers and discharge opening. Contact with the rotating impeller can amputate fingers, hands, and feet.
- Never attempt to unclog either the feed intake or discharge opening, remove or empty vacuum bag, or inspect and repair the machine while the engine is running. Shut the engine off and wait until all moving parts have come to a complete stop. Disconnect the spark plug wire and ground it against the engine.
- thrown and cause personal injury or damage to the machine.
- Always wear safety glasses or safety goggles during operation or while performing an adjustment or repair, to protect eyes. Thrown objects which ricochet can cause serious injury to the eyes.
- Wear sturdy, rough-soled work shoes and close-fitting slacks and shirts. Loose fitting clothes or jewelry can be caught in movable parts. Never operate this machine in bare feet or sandals. Wear leather work gloves when feeding material in the chipper chute.
- Before starting, check all bolts and screws for proper tightness to be sure the machine is in safe working condition. Also, visually inspect machine for any damage at frequent intervals.
- Maintain or replace safety and instructions labels, as necessary.
- To avoid personal injury or property damage use extreme care in handling gasoline. Gasoline is extremely flammable and the vapors are explosive. Serious personal injury can occur when gasoline is spilled on yourself or your clothes which can ignite. Wash your skin and change clothes immediately.
 - Use only an approved gasoline container.
 - Extinguish all cigarettes, cigars, pipes, and other sources of ignition.
 - Never fuel machine indoors.
 - Never remove gas cap or add while the engine is hot or running.
 - Allow engine to cool at least two minutes before refueling.
 - Never over fill fuel tank. Fill tank to no more than 1/2 inch below bottom of filler neck to provide space for fuel expansion.
 - Replace gasoline cap and tighten securely.
 - If gasoline is spilled, wipe it off the engine and equipment. Move machine to another area. Wait 5 minutes before starting the engine.

PREPARATION

- Thoroughly inspect the area where the equipment is to be used. Remove all rocks, bottles, cans, or other foreign objects which could be picked up or

- Never store the machine or fuel container inside where there is an open flame, spark, or pilot light (e.g. furnace, water heater, space heater, clothes dryer, etc.)
- To reduce a fire hazard, keep machine free of grass, leaves, or other debris build-up. Clean up oil fuel spillage and remove any fuel soaked debris.
- Allow machine to cool at least 5 minutes before storing.

OPERATION

- Do not put hands and feet near rotating parts or in the feeding chambers and discharge opening. Contact with the rotating impeller can amputate fingers, hands, and feet.
- Before starting the machine, make sure the chipper chute, feed intake, and cutting chamber are empty and free of all debris.
- Thoroughly inspect all material to be shredded and remove any metal, rocks, bottles, cans, or other foreign objects which could cause personal injury or damage to the machine.
- If the impeller strikes a foreign object or if your machine should start making an unusual noise or vibration, immediately shut the engine off. Allow the impeller to come to a complete stop. Disconnect the spark plug wire, ground it against the engine and perform the following steps:
 - Inspect for damage.
 - Repair or replace any damaged parts.
 - Check for any loose parts and tighten to assure continued safe operation.
- Do not allow an accumulation of processed material to build up in the discharge area. This can prevent proper discharge and result in kickback of material through the feed opening.
- Do not attempt to shred or chip material larger than specified on the machine or in this manual. Personal injury or machine damage could result.
- Never attempt to unclog either the feed intake or discharge opening while the engine is running. Shut the engine off, wait until all moving parts have stopped, disconnect the spark plug wire and ground it against the engine before clearing debris.
- Never operate without vacuum bag and discharge chute properly attached to the machine. Never empty or change vacuum bag while the engine is running. Zippered end of vacuum bag must be kept closed at all times during operation.
- Never operate without either the inlet nozzle or optional hose attachment properly attached to the machine. Never attempt to attach or change either attachment while the engine is running.
- Keep all guards, deflectors and safety devices in place and operating properly.

- Keep your face and body back and to the side of the chipper chute while feeding material into the machine to avoid accidental kickback injuries.
- Never operate this machine without good visibility or light. Always be sure of your footing and keep a firm hold on the handles.
- Do not operate this machine on a gravel surface.
- Do not operate this machine while under the influence of alcohol or drugs.
- Muffler and engine become hot and can cause a burn. Do not touch.
- Never pick up or carry machine while the engine is running.

MAINTENANCE AND STORAGE

- Never tamper with safety devices. Check their proper operation regularly.
- Check bolts and screws for proper tightness at frequent intervals to keep the machine in safe working condition. Also, visually inspect machine for any damage and repair, if needed.
- Before cleaning, repairing, or inspecting, stop the engine and make certain the impeller and all moving parts have stopped. Disconnect the spark plug wire and ground it against the engine to prevent unintended starting.
- Do not change the engine governor settings or overspeed the engine. The governor controls the maximum safe operating speed of the engine.
- Maintain or replace safety and instruction labels, as necessary.
- Follow this manual for safe loading, unloading, transporting, and storage of this machine.
- Never store the machine or fuel container inside where there is an open flame, spark or pilot light such as a water heater, furnace, clothes dryer, etc.
- Always refer to the operator's manual for proper instructions on off-season storage.
- If the fuel tank has to be drained, do this outdoors.
- Observe proper disposal laws and regulations for gas, oil, etc. to protect the environment.



WARNING - YOUR RESPONSIBILITY: Restrict the use of this power machine to persons who read, understand and follow the warnings and instructions in this manual and on the machine.

NOTE: Not all safety labels shown may apply to your chipper shredder vacuum.

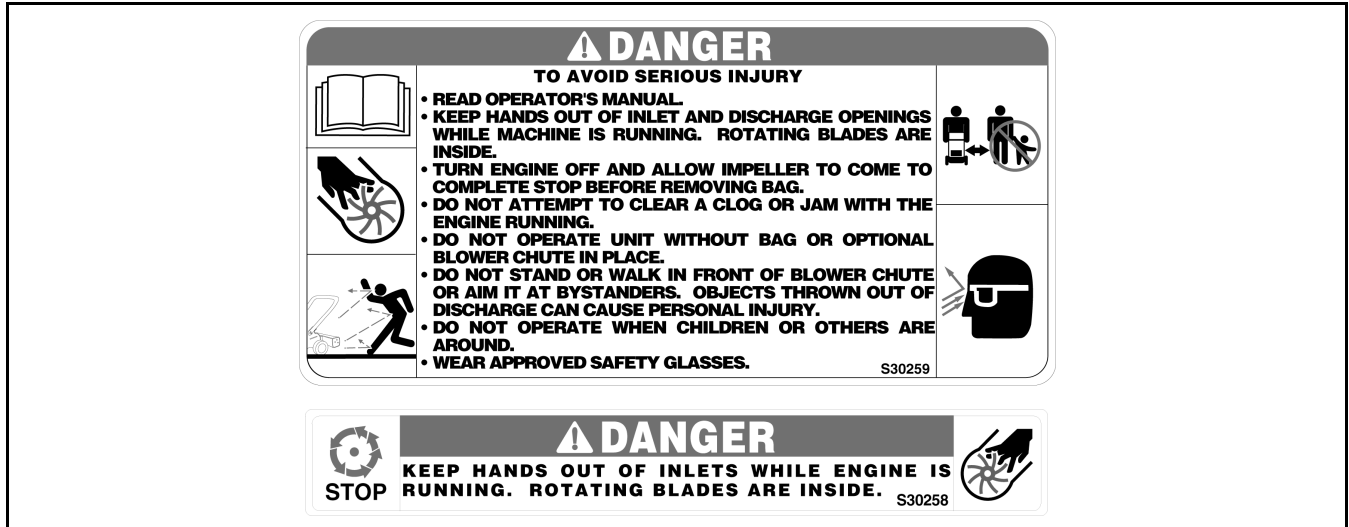

SECTION 2: ASSEMBLING YOUR CHIPPER SHREDDER VACUUM

IMPORTANT: This unit is shipped without gasoline or oil in the engine. Be certain to service engine with gasoline and oil as instructed in the separate engine manual before operating your machine.

NOTE: Reference to right or left hand side of the chipper shredder vacuum is observed from the operating position.

Removing Unit From Carton

- Remove staples, break glue on top flaps, or cut tape at carton end and peel along top flap to open carton.
- Remove loose parts if included with unit (i.e., operator's manual, etc.)
- Cut along corners, lay carton down flat, and remove packing material.
- Roll or slide unit out of carton and check carton thoroughly for loose parts.

Loose Parts In Carton (See Figure 1)

- Handle Assembly
- Bag
- Blower Chute (If Equipped)

Disconnecting Spark Plug Wire

Before setting up your chipper shredder vacuum, disconnect the spark plug wire from the spark plug and ground to a stud on the engine.

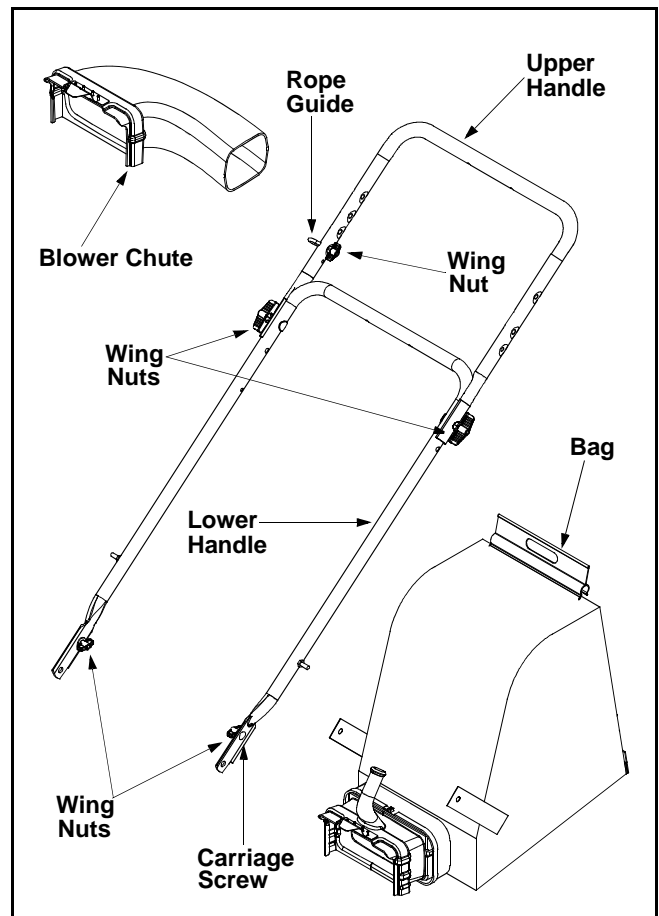

Figure 1

Attaching The Handle

- Unfold the upper handle until it aligns with the lower handle.
- Secure the two handles by tightening the wing nuts (carriage bolts must be seated properly into the handle).
- Remove the hairpin clips from the handle brackets on the chipper shredder vacuum and remove the carriage bolts and wing nuts from the lower handle. See Figure 2.
- Place each bottom hole in lower handle over pins on handle brackets and secure with hairpin clips.
- Insert carriage bolts thru upper hole in lower handle from the outside and secure with wing nuts.

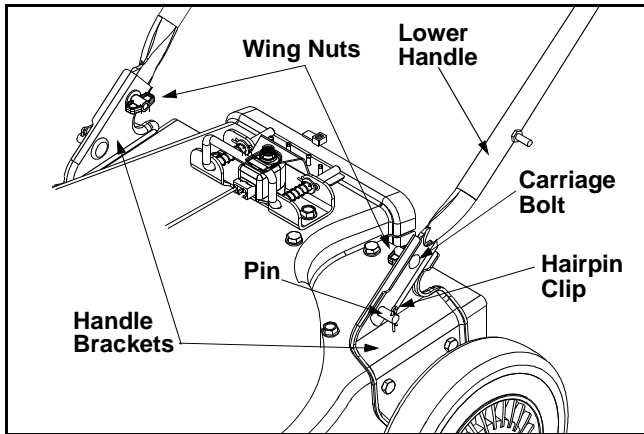

Figure 2

- Loosen the wing nut that secures the rope guide to the right side of upper handle.
- Pull the starter rope out of the engine slowly and slip the starter rope into the rope guide. Tighten the wing nut.

Attaching The Bag

- Grasp bag handle with one hand and pull locking rod on mounting bracket with other hand toward engine. See Figure 3.
- Slip bag over the rim of the discharge opening and release locking rod to secure bag in place.
- Place the straps on the bag **over** the lower handle, hooking them on the studs.
- Snap bag clip to the top of the lower handle.

NOTE: The safety switch button attached to the mounting bracket must be fully depressed by the front tab on the bag handle when securing the bag or the engine will not start.

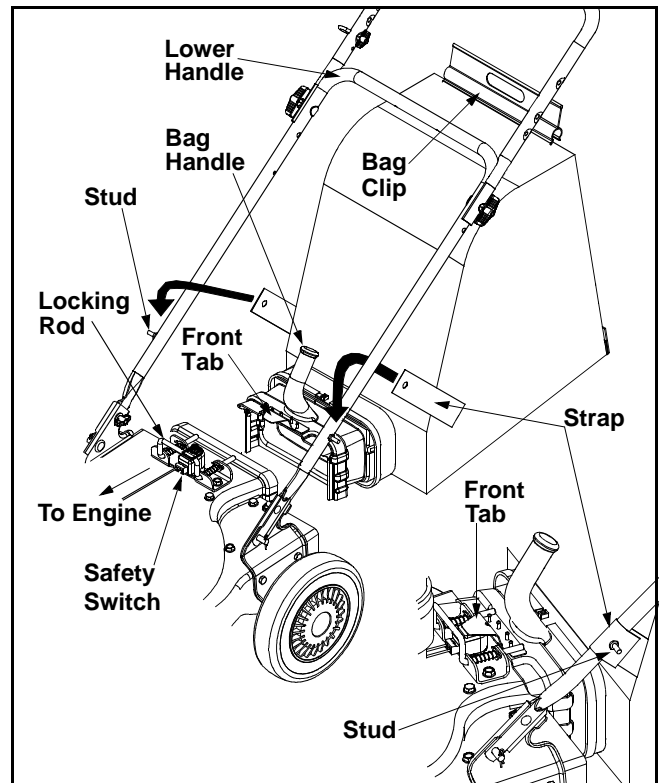

Figure 3

Attaching The Blower Chute (If Equipped)

- Grasp blower chute with one hand and pull locking rod on mounting bracket with other hand toward engine. See Figure 4.
- Slip blower chute over rim of the discharge opening and release locking rod to secure chute in place. Make sure the safety switch button is fully depressed by the front tab on the blower chute.
- Raise the nozzle height to the highest setting when using the blower chute. Refer to nozzle height adjustment in the OPERATION section.

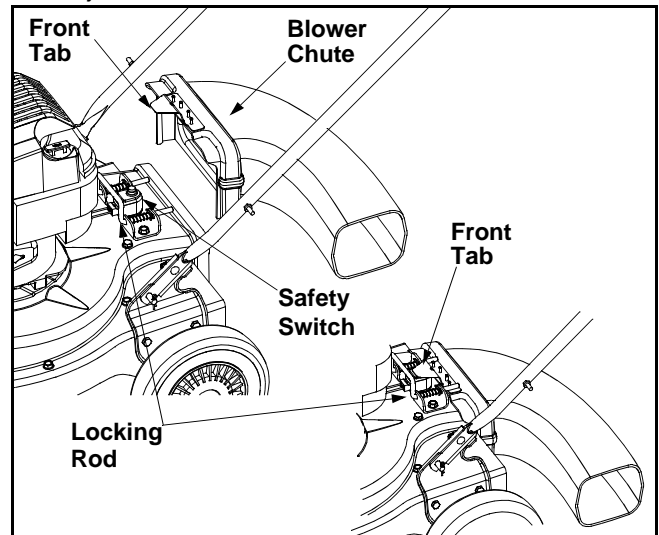

Figure 4

SECTION 3: KNOW YOUR CHIPPER SHREDDER VACUUM

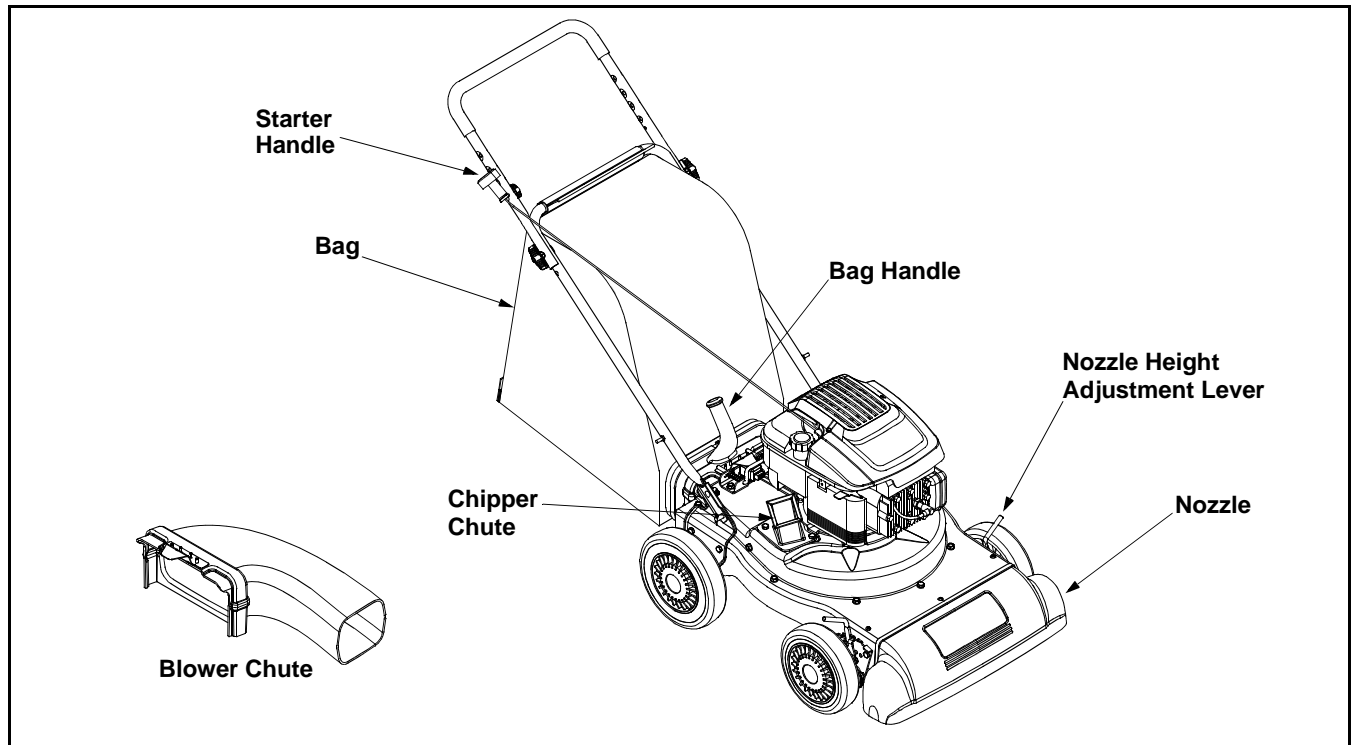

Figure 5

Read this operator's manual and safety rules before operating your chipper shredder vacuum. Compare the illustrations in Figure 5 with your unit to familiarize yourself with the location of various controls and adjustments. Save this manual for future reference.

Starter Handle

The starter handle is attached to the right upper handle. Stand behind unit and pull the starter handle to start engine. See Figure 5.

Bag

Collects shredded material fed through the chipper chute or vacuumed through the nozzle. See Figure 5.

Bag Handle

Used to grasp bag in order to assist in attaching, removing, and emptying bag. See Figure 5.

Chipper Chute

Allow twigs and small branches up to 1 1/2" in diameter to be fed into the impeller for chipping. See Figure 5.

Blower Chute (If Equipped)

When attached to unit the blower chute is used to blow or scatter yard waste such as leaves, pine needles, or small twigs across yard. See Figure 5.

Nozzle Height Adjustment Lever

Used to adjust the nozzle ground clearance ranging approximately 5/8" to 3 3/4".

Nozzle

Yard waste such as leaves and pine needles can be vacuumed up through the nozzle for shredding.

Throttle Control Lever (Not Shown)

The throttle control lever is located on the engine. It controls the engine's speed and stops the engine. See separate engine manual packed with unit for details.

Engine Controls

See the separate engine manual for the location and function of the controls on the engine.

Stopping Engine

- Move throttle control lever to STOP or OFF position.
- Disconnect spark plug wire from spark plug and ground against the engine.

SECTION 4: OPERATING YOUR CHIPPER SHREDDER VACUUM



WARNING: The operation of any chipper shredder vacuum can result in foreign objects being thrown into the eyes, which can damage your eyes severely. Always wear the safety glasses provided with this unit or eye shields before chipping or blowing and while performing any adjustments or repairs.

Gas And Oil Fill-Up

Service the engine with gasoline and oil as instructed in the separate engine manual packed with your chipper shredder vacuum. Read instructions carefully.



WARNING: Never fill fuel tank indoors with engine running or until the engine has been allowed to cool for at least two minutes after running.

Starting Engine

- Attach spark plug wire to spark plug. Make certain the metal cap on the end of the spark plug is fastened securely over the metal tip on the spark plug.
- Make sure safety switch wire is connected to engine and properly grounded.
- **Engines with choke lever:**
Move choke lever on engine to CHOKE position. (A warm engine may not require choking).
- **Engines with primer:**
Prime engine as instructed in separate engine manual.
- The throttle control is located on the engine. Move engine throttle control lever to FAST or ON position.
- Stand behind unit, grasp starter handle and pull rope out slowly until engine reaches start of compression cycle (rope will pull slightly harder at this point).
- Pull rope with a rapid, continuous, full arm stroke. Keep a firm grip on starter handle. Let rope rewind slowly.
- Repeat previous steps until engine fires. When engine starts, move choke control (if equipped) gradually to RUN position.



WARNING: Never run the engine indoors or in a poorly ventilated area. Engine exhaust contains carbon monoxide, an odorless and deadly gas.

To Empty Bag

- Unhook bag straps from the lower handle and unsnap bag clip from the top of lower handle. See Figure 6.

- Grasp bag handle with one hand and pull lock rod on mounting bracket with other hand toward engine to release.
- Remove bag from rim of the discharge opening. Refer to Figure 3.
- Twist the two buttons on the back of the bag to unlock and empty contents. See Figure 6.
- Hold bag handle and bag clip while emptying the contents.
- Compress bag opening and fold inner flap over opening.
- Fold outer flap over inner flap and insert buttons on the bag through metal outlets.
- Twist the buttons to lock bag.

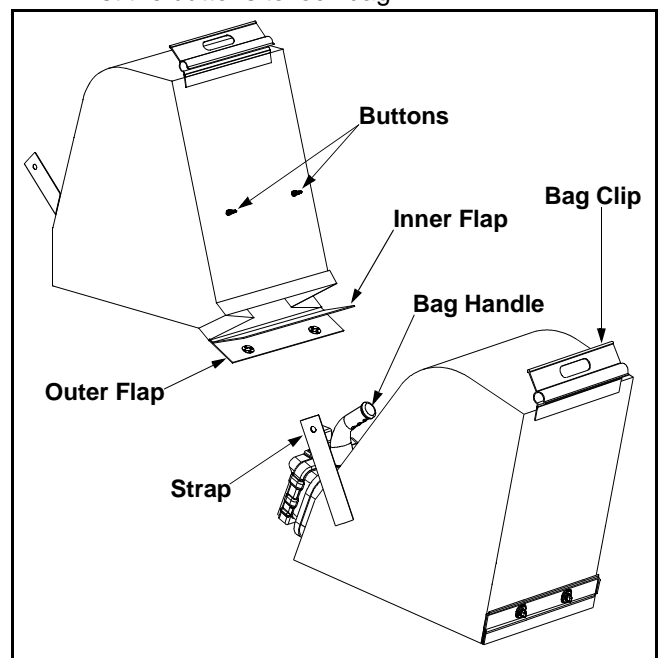

Figure 6

To Remove Blower Chute (If Equipped)

- Grasp blower chute with one hand and pull lock rod on mounting bracket with other hand toward engine to release. Refer to Figure 4.
- Remove blower chute from rim of the discharge opening.

Using the Chipper Shredder Vacuum

Place both hands on top of upper handle to push unit over yard waste. Yard waste such as leaves and pine needles can be vacuumed up through the nozzle for shredding. After material has been shredded by the flail blades on the impeller assembly, it will be discharged into catcher bag or through blower chute. Do not attempt to shred or chip any material other than vegetation found in a normal yard (i.e. branches, leaves, twigs, etc.) Avoid fibrous plants such as tomato

vines until they are thoroughly dried out. Materials such as stalks or heavy branches up to 1 1/2" in diameter may be fed into the chipper chute. See Figure 7.



WARNING: Do not at any time make any adjustments without first stopping engine and disconnecting spark plug wire.

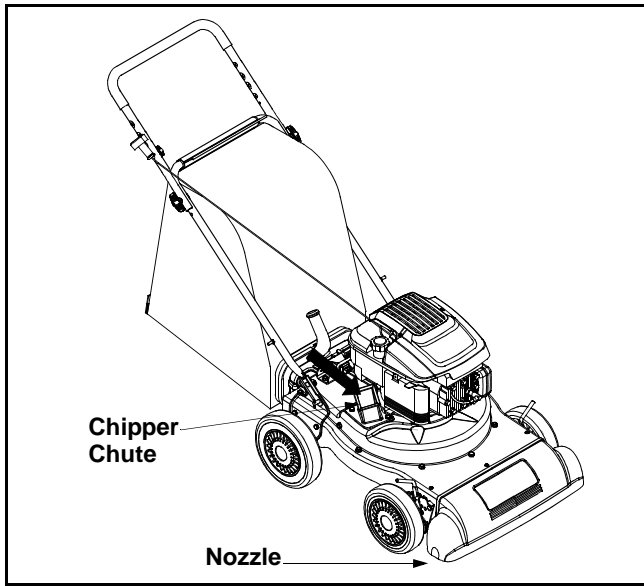

Figure 7

IMPORTANT: The flail screen is located inside the housing in the discharge area. If the flail screen becomes clogged, remove and clean as instructed in SECTION 5: MAINTAINING YOUR CHIPPER SHREDDER VACUUM. For best performance, it is also important to keep the chipper blade sharp.

Nozzle Height Adjustment

The nozzle can be adjusted to any five positions, ranging from 5/8" to 3 3/4" ground clearance. The nozzle height has to be adjusted according to the conditions. Move the height adjustment levers forward or backward to adjust the nozzle upwards or downwards. See Figure 8.

NOTE: In general, raise the nozzle height to vacuum a thick layer of leaves or to operate with the blower chute and lower the nozzle height for smoother surfaces.

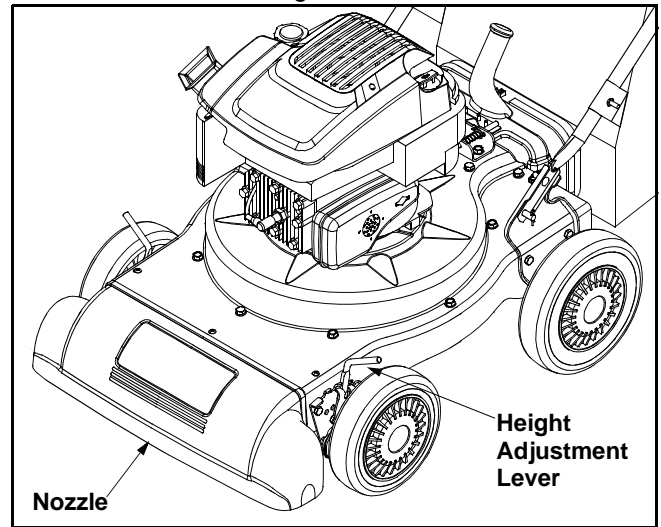

Figure 8

SECTION 5: MAINTAINING YOUR CHIPPER SHREDDER VACUUM

Customer Responsibilities

MAINTENANCE SCHEDULE		Before each use	Every 25 hours	Every 50 hours	Every 100 hours	Once a season	Before storage	SERVICE DATES					
PRODUCT	Lubricate Wheels					✓							
	Lubricate Nozzle Levers					✓							
	Lubricate Locking Rod					✓							
	Check Chipper Blade		✓			✓							
ENGINE	Change Oil		✓				✓						
	Check Air Filter		✓			✓							
	Clean Engine	✓					✓						
	Check Spark Plug			✓		✓							



WARNING: Always stop engine and disconnect spark plug wire before cleaning, lubricating or doing any kind of maintenance on your machine.

Lubrication

Wheels: Lubricate each wheel shoulder screw once a season with light oil. See Figure 9.

Nozzle height adjustment levers: Lubricate the pivot points of the nozzle height adjustment levers once a season with light oil. See Figure 9.

Engine: Follow the separate engine manual packed with you unit for lubrication instructions.

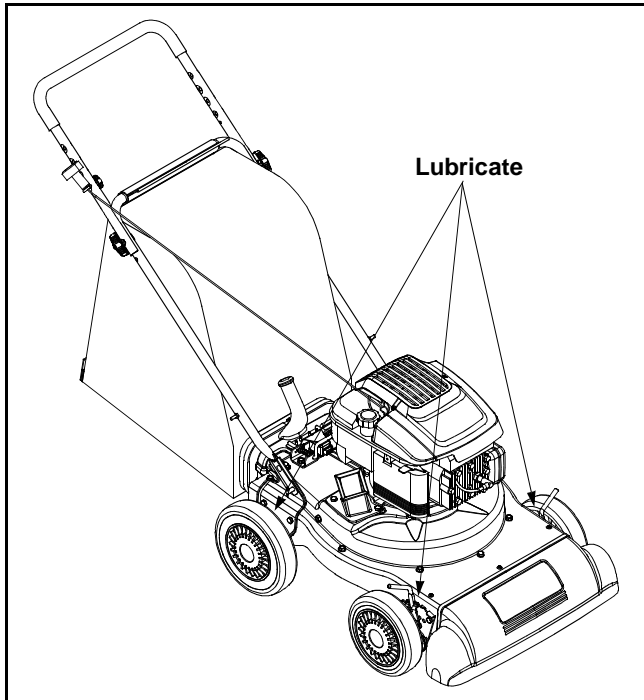

Figure 9

Maintenance

Engine

Refer to the separate engine manual for all engine maintenance instructions.

- Check **engine oil level** before each use as instructed in the separate engine manual packed with your unit. Read and follow instructions carefully.
- Clean **air cleaner** every 25 hours under normal conditions or once a season. Clean every few hours under extremely dusty conditions. To service the air cleaner, refer to the separate engine manual packed with your unit.
- The **spark plug** should be cleaned and the gap reset once a season. Check engine manual for correct plug type and gap specifications.

Removing The Flail Screen

If the discharge area becomes clogged, remove the flail screen and clean area as follows:

- Stop the engine and make certain the chipper shredder vacuum has come to a complete stop.
- Disconnect spark plug wire from spark plug and ground against the engine.
- Remove the bag or blower chute from the unit as instructed in the OPERATION section to obtain access to flail screen. See Figure 10.

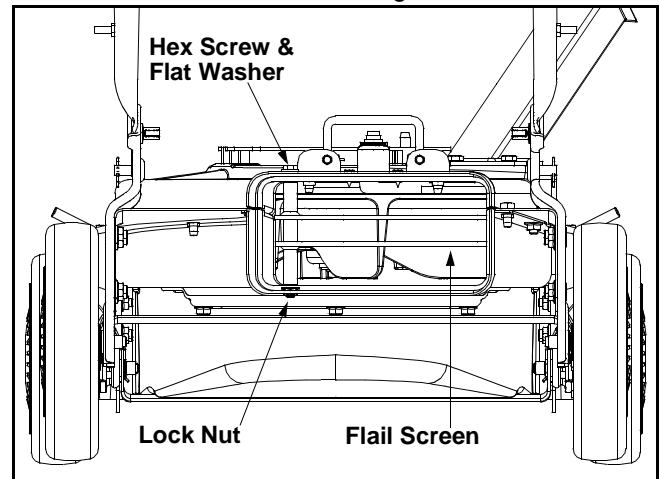

Figure 10

- Remove hex screw on right side of unit that attaches to the flail screen. See Figure 11.
- Remove hex screw and flat washer on top of rear housing mounting bracket and the lock nut that secures flail screen. See Figure 10.
- Remove and clean the screen by scraping or washing with water. Reinstall the flail screen.

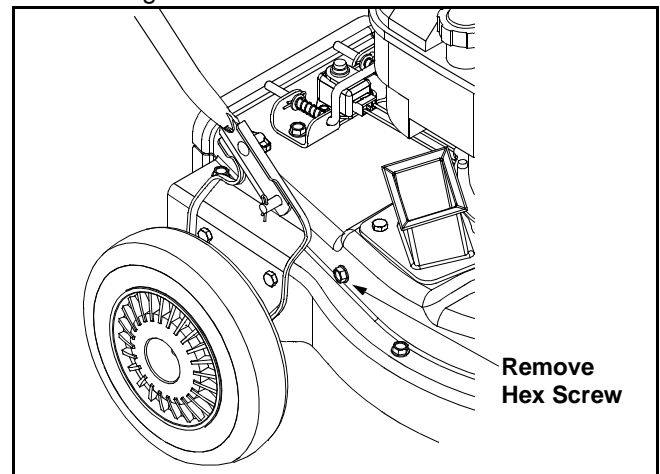

Figure 11

Sharpening Or Replacing Chipper Blade

Because the engine on this unit has a tapered crankshaft, a special impeller tool (part number 753-0638) is required to remove the impeller assembly. For further assistance, contact your local service dealer.

NOTE: When tipping the unit, empty the fuel tank and keep spark plug side up.

- Disconnect the spark plug wire and ground it away from the spark plug.
- Remove the front hubcaps, shoulder screws, wave washers, and bell washers that attach to the front wheels. See Figure 12.
- Remove the shoulder screws that go through the pivot arms and height bracket adjusters to the front support brace.

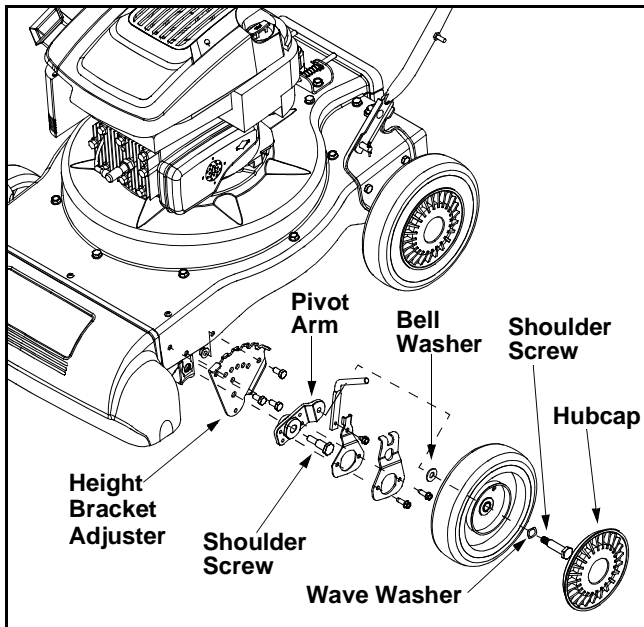

Figure 12

- Remove the three screws on the upper housing that secure the nozzle cover and the nine screws that secure the lower housing to the upper housing. See Figure 13.

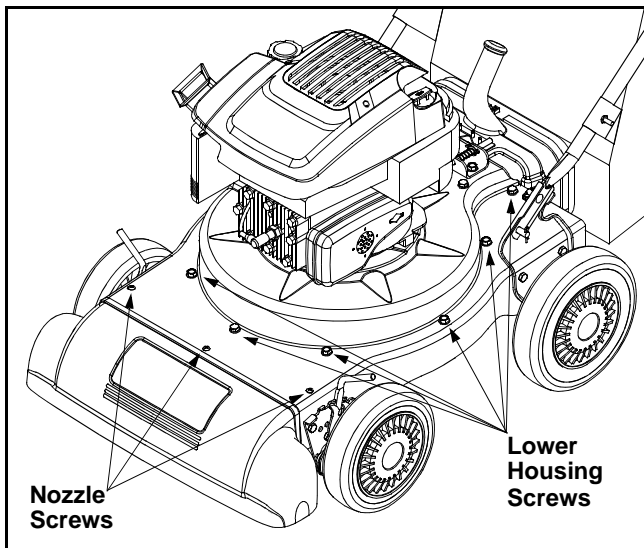

Figure 13

- Remove lock nut that secures flail screen to the lower housing. The flail screen does not have to be removed.
- Remove the hex bolt, lock washer, and flat washer that secure the impeller assembly to the crankshaft. See Figure 14.

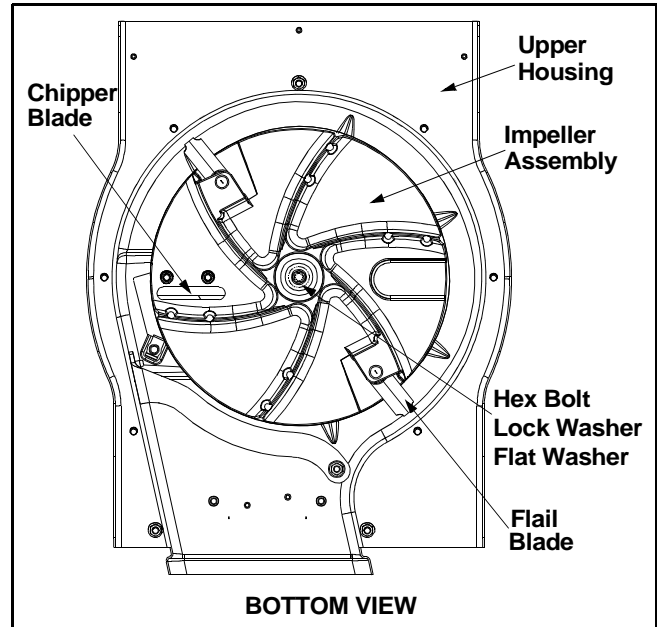

Figure 14

- Apply lubricant to the threads of impeller removal tool and then thread the tool into the crankshaft. Stop when the impeller assembly can move on the crankshaft.
- Remove the impeller assembly from the crankshaft. Unthread the impeller removal tool from the impeller assembly.
- Remove the blade using a 3/16" allen wrench on the outside of the blade and 1/2" wrench on the impeller assembly.
- Replace or sharpen chipper blade.
- When sharpening blade, protect hands by using gloves and follow the original angle of grind.
- Reassemble by performing the previous steps in reverse order.
- Tighten blade screws to 210-250 in-lbs. Tighten impeller bolt to 375-425 in-lbs.

Storing Your Chipper Shredder Vacuum

- Clean the equipment thoroughly.
- Wipe equipment with a oiled rag to prevent rust.
- Refer to engine manual for correct engine storage instructions
- Store unit in a clean, dry area. Do not store next to corrosive materials such as fertilizer.

SECTION 6: TROUBLESHOOTING

Problem	Cause	Remedy
Engine fails to start	<ol style="list-style-type: none"> 1. Spark plug wire disconnected. 2. Fuel tank empty or stale fuel. 3. Throttle control lever not in correct starting position. (If Equipped) 4. Choke not in CHOKE position. 5. Blocked fuel line. 6. Faulty spark plug. 	<ol style="list-style-type: none"> 1. Connect wire to spark plug. 2. Fill tank with clean, fresh gasoline. 3. Move throttle lever to FAST position. 4. Move choke to CHOKE position. 5. Clean fuel line. 6. Clean, adjust gap, or replace.
Engine runs erratic	<ol style="list-style-type: none"> 1. Spark plug wire loose. 2. Unit running on CHOKE. 3. Blocked fuel line or stale fuel. 4. Water or dirt in fuel system. 5. Dirty air cleaner. 6. Carburetor out of adjustment. 	<ol style="list-style-type: none"> 1. Connect and tighten spark plug wire. 2. Move choke lever (if equipped) to OFF position. 3. Clean fuel line; fill tank with clean, fresh gasoline 4. Drain fuel tank. Refill with fresh fuel. 5. Clean or replace air cleaner. 6. See authorized service dealer.
Too much vibration	<ol style="list-style-type: none"> 1. Loose parts or damaged impeller. 	<ol style="list-style-type: none"> 1. See authorized service dealer.
Engine overheats	<ol style="list-style-type: none"> 1. Engine oil level low. 2. Dirty air cleaner. 3. Carburetor not adjusted properly. 	<ol style="list-style-type: none"> 1. Fill crankcase with proper oil. 2. Clean or replace air cleaner. 3. See authorized service dealer.
Occasional skip (hesitates) at high speed	<ol style="list-style-type: none"> 1. Spark plug gap too close. 	<ol style="list-style-type: none"> 1. Adjust gap to .030".
Unit does not discharge	<ol style="list-style-type: none"> 1. Discharge chute clogged. 2. Foreign object lodged in impeller. 3. Low engine RPM 4. Vacuum bag is full. 	<ol style="list-style-type: none"> 1. Stop engine immediately and disconnect spark plug wire. Clean flail screen and inside of discharge opening. 2. Stop engine and disconnect spark plug wire. Remove lodged object. 3. Always run engine at full throttle. 4. Empty bag.
Rate of discharge slows considerably or composition of discharged material changes.	<ol style="list-style-type: none"> 1. Low engine RPM. 2. Chipper blade dull. 	<ol style="list-style-type: none"> 1. Always run engine at full throttle. 2. Replace chipper blade or see your authorized service dealer.

NOTE: For repairs beyond the minor adjustments listed above, contact your nearest authorized service dealer.

NOTES

Model 24A-020D401

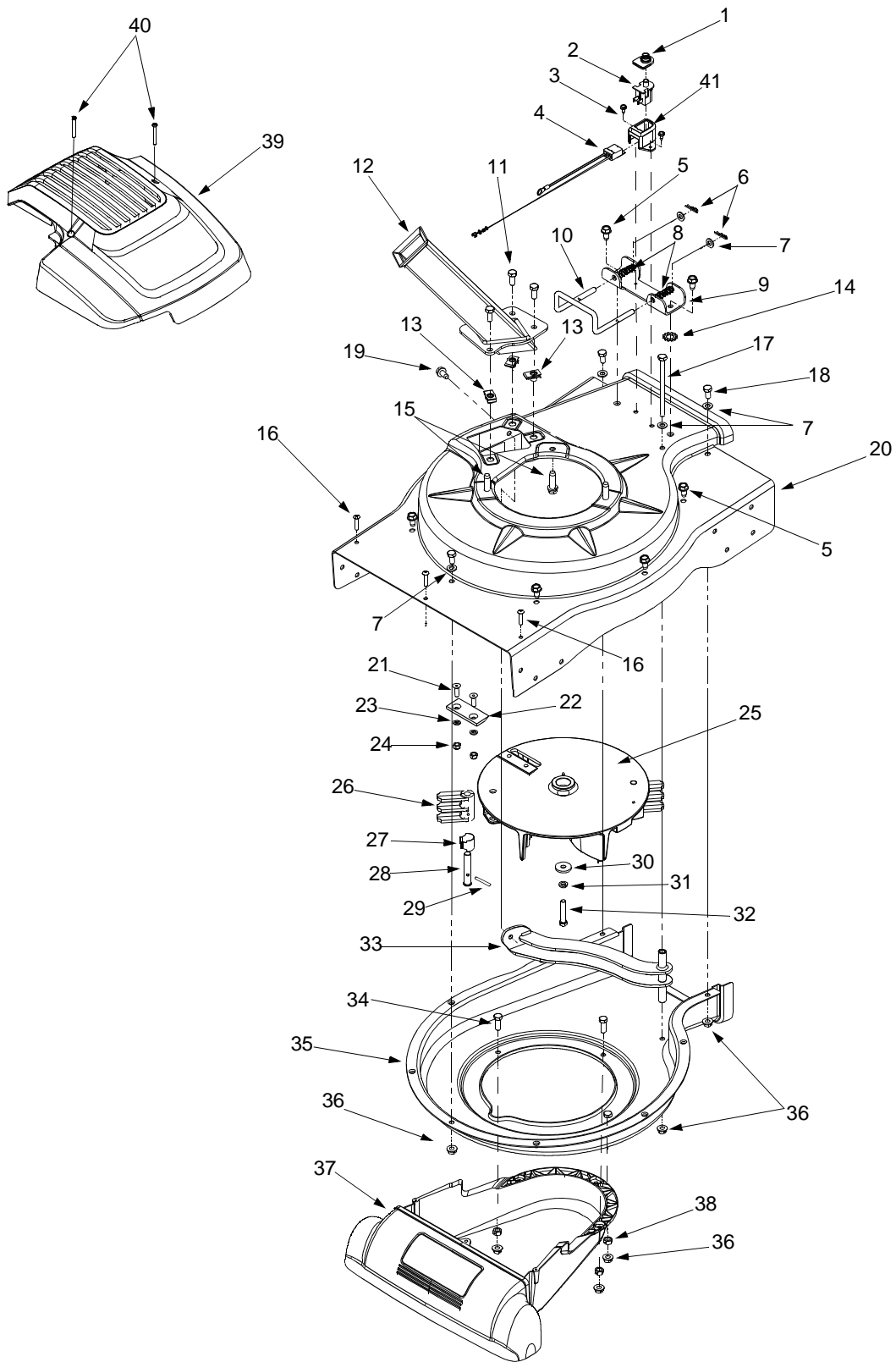

Model 24A-020D401

Ref. No.	Part No.	Part Description	Ref. No.	Part No.	Part Description
1.	725-1700	Switch Cover	22.	781-0490	Chipper Blade
2.	725-3166	Safety Switch	23.	736-0119	Lock Washer 5/16
3.	710-0224	Hex Washer Screw #10-16 x.50	24.	712-0411	Hex Lock Nut 5/16-24
4.	629-0920	Wire Harness	25.	681-0152	Impeller Assembly
5.	710-0604	Hex Washer Screw 5/16-18 x.625	26.	719-0329	Flail Blade
6.	714-0104	Cotter Pin	27.	781-0735	Pin Clip
7.	736-0264	Flat Washer.330 ID x.630 OD	28.	711-1401	Clevis Pin
8.	732-0962	Compression Spring	29.	715-0166	Spiral Pin
9.	781-0778	Mounting Bracket	30.	736-0247	Flat Washer.375 ID x 1.25 OD
10.	747-1153	Lock Rod	31.	736-0217	Lock Washer 3/8
11.	710-3008	Hex Cap Screw 5/16-18 x.75	32.	710-0818	Hex Cap Screw 3/8-24 x 2.0
12.	681-0122	Chipper Chute Assembly	33.	681-0154	Screen Assembly
13.	726-0454	U-Clip Lock Nut 5/16-18	34.	710-3038	Hex Cap Screw 5/16-18 x.875
14.	736-0607	External Lock Washer 5/16	35.	781-0721	Lower Housing
15.	710-0502A	Hex Washer Screw 3/8-16 x 1.25	36.	712-3004A	Lock Nut 5/16-18
16.	710-0969	Screw #12-16 x 1.0	37.	731-2265	Nozzle Cover
17.	710-3195	Hex Cap Screw 5/16-18 x 4.5	38.	712-0158	Lock Nut 5/16-18
18.	710-3025	Hex Cap Screw 5/16-18 x.625	39.	731-1402B	Shroud
19.	710-0604A	Hex Washer Screw 5/16-18 x.625	40.	710-1256	Screw #8-18 x 1.25
20.	781-0720	Upper Housing	41.	731-1613	Safety Switch Cover
21.	710-1054	Hex Screw 5/16-24 x 1.0			

NOTE: For **painted parts**, please refer to the list of color codes below. Please add the applicable color code, wherever needed, to the part number to order a replacement part. For instance, if a part numbered 700-sextets is painted Yard-Man Green, the part number to order would be 700-sextets-0665.

Yard-Man Green: 0665

Yard-Man Yellow: 0674

Powder Black: 0637

Model 24A-020D401

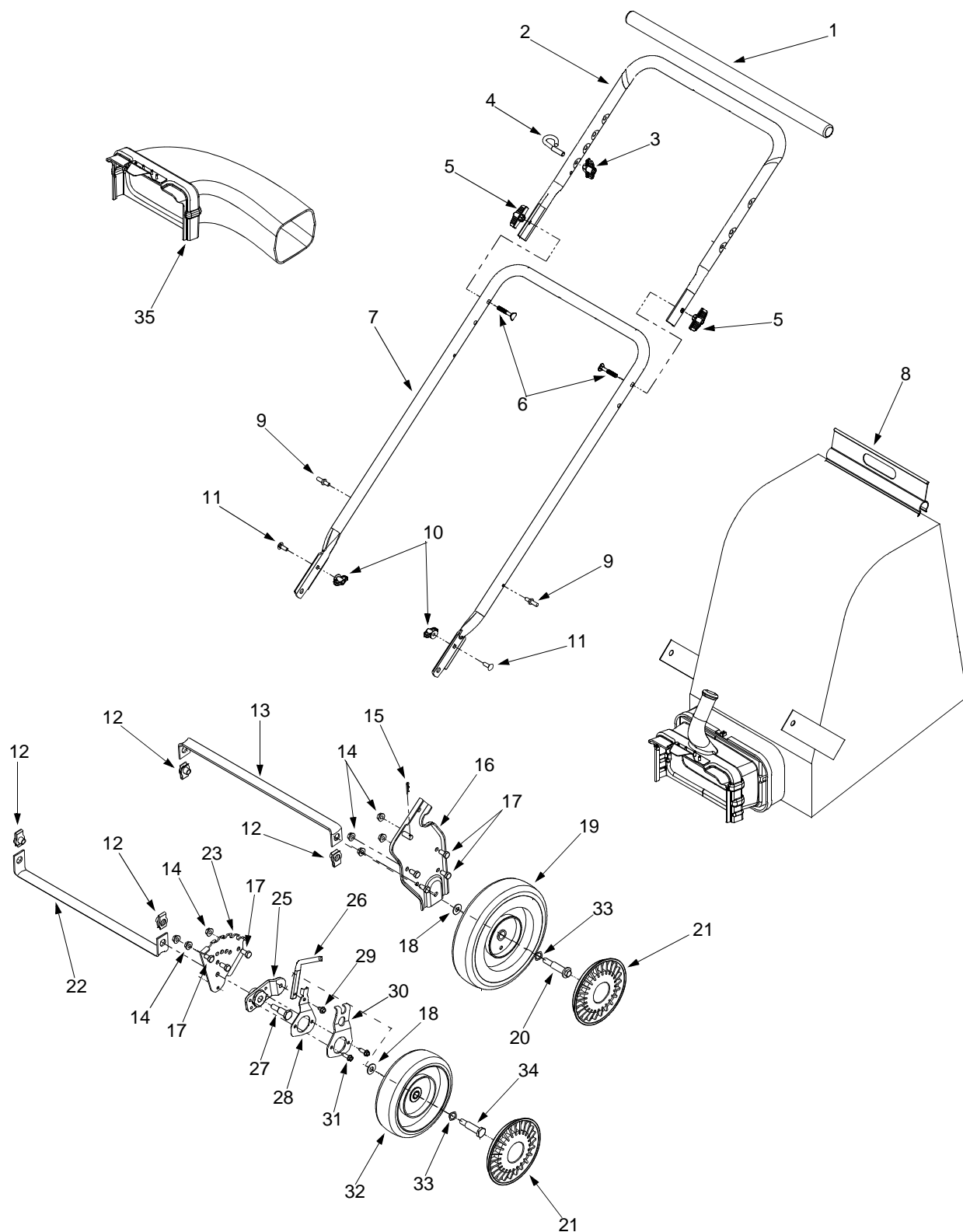

Model 24A-020D401

Ref. No.	Part No.	Part Description	Ref. No.	Part No.	Part Description
1.	720-0295	Foam Grip	18.	736-0105	Bell Washer.401 ID x.870 OD
2.	749-0438C	Upper Handle	19.	734-1992	Wheel 9 x 2
3.	720-0279	Knob	20.	738-1015	Shoulder Screw 3/8-16
4.	710-1205	Eye Bolt	21.	731-1426	Hubcap
5.	720-0314	Handle Knob 5/16-18	22.	781-0725	Front Wheel Support Brace
6.	710-1174	Carriage Bolt	23.	781-0765	Hgt Bracket Adjuster LH
7.	749-0907A	Lower Handle		781-0766	Height Brkt Adj RH (Not Shown)
8.	664-0090	Bag Assembly	25.	748-0417	Pivot Arm
9.	711-1293	Studs	26.	747-1100	Handle Height Adjuster
10.	712-0397	Wing Nut 1/4-20	27.	738-1017	Shoulder Screw 3/8-16
11.	710-0703	Carriage Screw 1/4-20 x.75	28.	732-0864	Height Adjuster Plate Spring
12.	726-0453	Lock U-Clip Nut 3/8-16	29.	710-0653	Hex Washer Screw 1/4-20 x .375
13.	781-0777	Rear Wheel Support Brace	30.	782-0578	Spring Lever Support Bracket
14.	712-3004A	Flange Lock Nut 5/16-18	31.	710-0642	Hex Washer Screw 1/4-20 x .75
15.	714-0104	Cotter Pin	32.	734-1978	Wheel 8 x 2
16.	681-0155	Handle Bracket Ass'y LH	33.	736-0232	Wave Washer .531 ID x .781 OD
	681-0156	Hndle Brkt Ass'y RH (Not Shown)	34.	738-0213	Shoulder Screw
17.	710-3025	Hex Cap Screw 5/16-18 x.625	35.	OEM-290-012	Blower Chute Ass'y (If Equipped)

MANUFACTURER'S LIMITED WARRANTY FOR:



The limited warranty set forth below is given by MTD PRODUCTS INC ("MTD") with respect to new merchandise purchased and used in the United States, its possessions and territories.

MTD warrants this product against defects in material and workmanship for a period of two (2) years commencing on the date of original purchase and will, at its option, repair or replace, free of charge, any part found to be defective in material or workmanship. This limited warranty shall only apply if this product has been operated and maintained in accordance with the Operator's Manual furnished with the product, and has not been subject to misuse, abuse, commercial use, neglect, accident, improper maintenance, alteration, vandalism, theft, fire, water or damage because of other peril or natural disaster. Damage resulting from the installation or use of any accessory or attachment not approved by MTD Products Inc. for use with the product(s) covered by this manual will void your warranty as to any resulting damages.

Normal wear parts or components thereof are subject to separate terms as follows: All normal wear part or component failures will be covered on the product for a period of 90 days regardless of cause. After 90 days, but within the two year period, normal wear part failures will be covered ONLY IF caused by defects in material or workmanship of OTHER component parts. Normal wear parts and components include, but are not limited to, belts, blades, blade adapters, grass bags, rider deck wheels, seats, snow thrower skid shoes, shave plates and tires. Batteries are covered by a 90-day limited replacement warranty.

HOW TO OBTAIN SERVICE: Warranty service is available, WITH PROOF OF PURCHASE THROUGH YOUR LOCAL AUTHORIZED SERVICE DEALER. To locate the dealer in your area, please check for a listing in the Yellow Pages or contact the Customer Service Department of MTD PRODUCTS INC by calling 1-800-800-7310 or writing to P.O. Box 368022, Cleveland, Ohio 44136-9722.

This limited warranty does not provide coverage in the following cases:

- a. The engine or component parts thereof. These items carry a separate manufacturer's warranty. Please refer to the applicable manufacturer's warranty on these items.
- b. Log splitter pumps, valves and cylinders have a separate one year warranty.

- c. Routine maintenance items such as lubricants, filters, blade sharpening and tune-ups, or adjustments such as brake adjustments, clutch adjustments or deck adjustments; and normal deterioration of the exterior finish due to use or exposure.

- d. MTD does not extend any warranty for products sold or exported outside of the United States of America, its possessions and territories, except those sold through MAD's authorized channels of export distribution.

No implied warranty, including any implied warranty of merchantability or fitness for a particular purpose, applies after the applicable period of express written warranty above as to the parts as identified. No other express warranty or guaranty, whether written or oral, except as mentioned above, given by any person or entity, including a dealer or retailer, with respect to any product shall bind MTD. During the period of the Warranty, the exclusive remedy is repair or replacement of the product as set forth above. (Some states do not allow limitations on how long an implied warranty lasts, so the above limitation may not apply to you.)

The provisions as set forth in this Warranty provide the sole and exclusive remedy arising from the sales. MTD shall not be liable for incidental or consequential loss or damages including, without limitation, expenses incurred for substitute or replacement lawn care services, for transportation or for related expenses, or for rental expenses to temporarily replace a warranted product. (Some states do not allow the exclusion or limitation of incidental or consequential damages, so the above exclusion or limitation may not apply to you.)

In no event shall recovery of any kind be greater than the amount of the purchase price of the product sold. Alteration of the safety features of the product shall void this Warranty. You assume the risk and liability for loss, damage, or injury to you and your property and/or to others and their property arising out of the use or misuse or inability to use the product.

This limited warranty shall not extend to anyone other than the original purchaser, original lessee or the person for whom it was purchased as a gift.

How State Law Relates to this Warranty: This limited warranty gives you specific legal rights, and you may also have other rights which vary from state to state.