

Three-Phase Transformer Banks

RENEWABLE ENERGY

THREE-PHASE TRANSFORMER BANKS

Courseware Sample

















by
the staff
of
Lab-Volt Ltd.

Copyright © 2011 Lab-Volt Ltd.







All rights reserved. No part of this publication may be reproduced, in any form or by any means, without the prior written permission of Lab-Volt Ltd.

Safety Symbols

The following safety symbols may be used in this manual and on the Lab-Volt equipment:

Symbol	Description
	DANGER indicates a hazard with a high level of risk which, if not avoided, will result in death or serious injury.
	WARNING indicates a hazard with a medium level of risk which, if not avoided, could result in death or serious injury.
	CAUTION indicates a hazard with a low level of risk which, if not avoided, could result in minor or moderate injury.
	CAUTION used without the <i>Caution, risk of danger</i> sign  , indicates a hazard with a potentially hazardous situation which, if not avoided, may result in property damage.
	Caution, risk of electric shock
	Caution, hot surface
	Caution, risk of danger
	Caution, lifting hazard
	Caution, hand entanglement hazard
	Direct current
	Alternating current
	Both direct and alternating current
	Three-phase alternating current
	Earth (ground) terminal
	Protective conductor terminal
	Frame or chassis terminal

Safety Symbols

Symbol	Description
	Equipotentiality
	On (supply)
	Off (supply)
	Equipment protected throughout by double insulation or reinforced insulation
	In position of a bi-stable push control
	Out position of a bi-stable push control

Foreword

Three-phase transformer banks serve the same purpose in three-phase circuits as single-phase power transformers in single-phase circuits. This means that three-phase transformer banks are primarily used to either step-up (i.e., to increase) the voltage from the primary windings to the secondary windings, or to step-down (i.e., to decrease) the voltage from the primary windings to the secondary windings. Since three-phase ac power is widely used worldwide for both power transmission and power distribution, three-phase transformer banks are one of the most common electrical components and are essential to any three-phase ac power network.

Many three-phase transformer configurations are possible when connecting the primary and secondary windings of a three-phase transformer bank. Each configuration presents different characteristics. When connecting a three-phase transformer bank in a circuit, it is therefore important to determine which characteristics are advantageous to the circuit, and to choose the three-phase transformer configuration accordingly. The four most common three-phase transformer configurations are the wye-wye, delta-delta, wye-delta, and delta-wye configurations.

This course, Three-Phase Transformer Banks, teaches the basic concepts of three-phase transformer banks. Students are introduced to the different characteristics of three-phase transformer banks. They learn how to connect the windings of three-phase transformer banks in wye or delta. Students are also introduced to the four most common types of three-phase transformer configurations: wye-wye, delta-delta, wye-delta, and delta-wye. They determine the voltage, current, and phase relationships between the primary windings and the secondary windings of three-phase transformer banks for each of these configurations. Students also verify the theory presented in the manual by performing circuit measurements and calculations.



Three-phase transformer bank used for power distribution.

Table of Contents

Introduction	Three-Phase Transformer Banks	1
	<i>Introduction to three-phase power transformers. Types of three-phase power transformers. Connecting the windings of three-phase transformer banks in wye and in delta.</i>	
Exercise 1	Three-Phase Transformer Configurations	5
	<i>Common three-phase transformer configurations. Voltage, current, and phase relationships of the four common three-phase transformer configurations. Summary of the characteristics of the four common three-phase transformer configurations. Uses of three-phase transformer banks.</i>	
Appendix A	Equipment Utilization Chart	27
Appendix B	Glossary of New Terms	29
Appendix C	Impedance Table for the Load Modules	31
	Index of New Terms	33
	Bibliography	35
	We Value Your Opinion!	37

Sample Exercise
Extracted from
Student Manual

Three-Phase Transformer Configurations

EXERCISE OBJECTIVE When you have completed this exercise, you will know how to connect three-phase transformer banks in wye-wye, delta-delta, wye-delta, and delta-wye configurations. You will determine what are the voltage, current, and phase relationships between the primary windings and the secondary windings of a three-phase transformer bank for each of these configurations. You will be familiar with the different uses of three-phase transformer banks in three-phase ac power circuits.

DISCUSSION OUTLINE The Discussion of this exercise covers the following points:

- Common three-phase transformer configurations
- Voltage, current, and phase relationships of the four common three-phase transformer configurations
- Summary of the characteristics of the four common three-phase transformer configurations
- Uses of three-phase transformer banks

DISCUSSION

Common three-phase transformer configurations

Many **three-phase transformer configurations** are possible when connecting the primary and secondary windings of a three-phase transformer bank. Each configuration presents different characteristics. When connecting a three-phase transformer bank in a circuit, it is therefore important to determine which characteristics are advantageous to the circuit, and to choose the appropriate three-phase transformer configuration accordingly.

The four most common three-phase transformer configurations are wye-wye, delta-delta, wye-delta, and delta-wye configurations. Each of these configurations is shown in Figure 3. The letter (A, B, or C) beside each winding in Figure 3 identifies one of the transformers in a three-phase transformer bank. This allows the primary and secondary windings of each transformer in the three-phase transformer bank to be easily located in the diagrams of Figure 3.

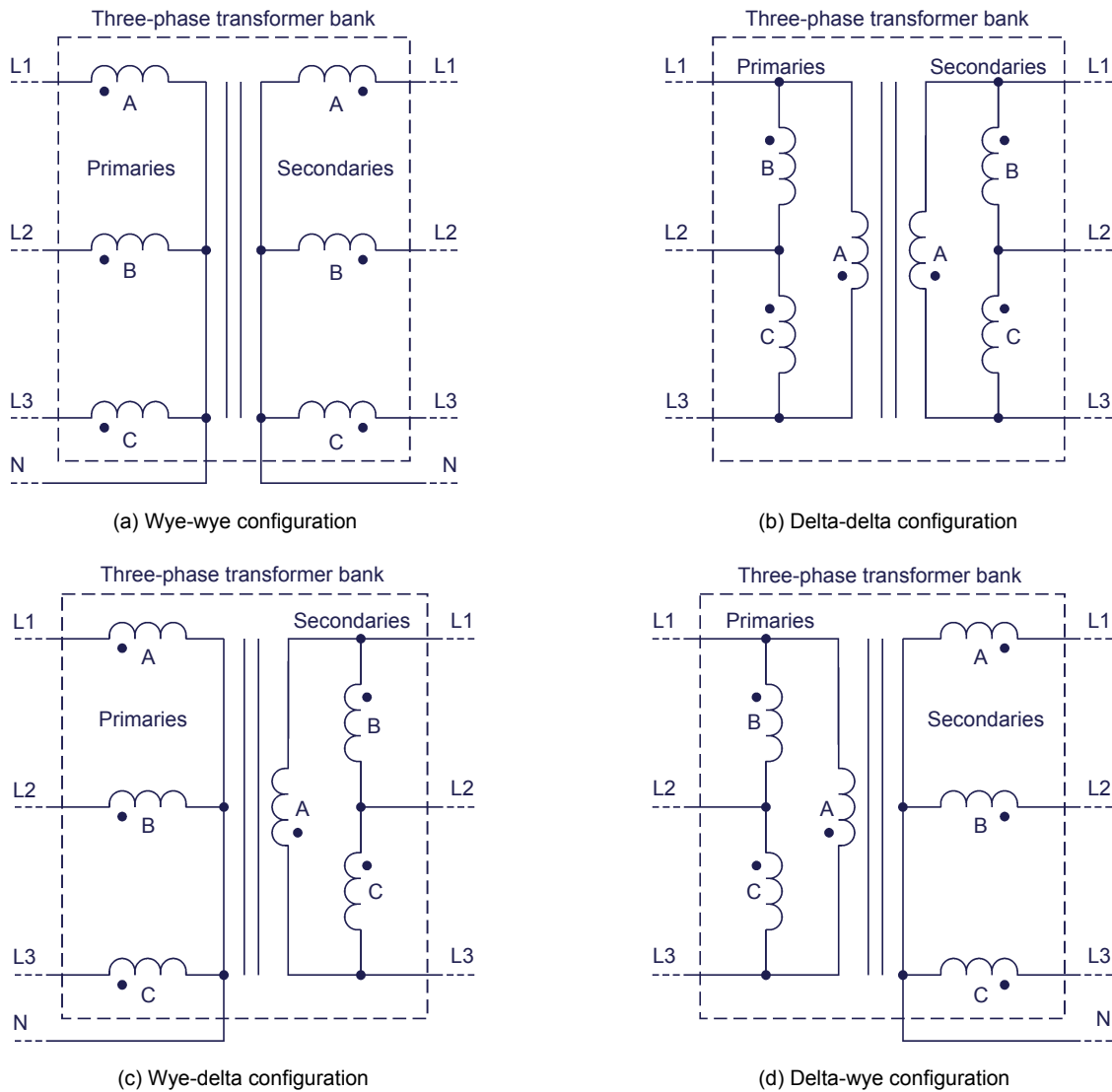

Figure 3. The four most common three-phase transformer configurations.

As you can see from the figure, wye-connected windings use 4 wires, while delta-connected windings use only 3 wires. When setting up a three-phase transformer bank in a wye-delta or delta-wye configuration, this property allows the number of wires in a three-phase ac circuit to be modified from 4 wires to 3 wires, or from 3 wires to 4 wires, respectively. Either of these configurations can be a significant advantage, depending on the requirements of the particular application in which it is used.

Voltage, current, and phase relationships of the four common three-phase transformer configurations

The most determining characteristics of each three-phase transformer configuration mentioned in the previous section (i.e., the wye-wye, delta-delta, wye-delta, and delta-wye configurations) are their respective voltage, current, and phase relationships between the primary windings and the secondary

windings. The following three sections discuss these relationships for each three-phase transformer configuration. Note that, as wye-wye and delta-delta configurations have similar voltage, current, and phase relationships, both configurations are covered in the same section. Also note that, in the following sections, the turns ratio of each transformer in the three-phase transformer bank is assumed to be equal to 1:1. This allows observation of the effects each configuration has on the voltage, current, and phase relationships of the three-phase transformer bank, independently of the turns ratio.

Wye-wye and delta-delta configurations

When a three-phase transformer bank is connected in either a wye-wye or a delta-delta configuration, the voltage, current, and phase relationships between the primary windings and the secondary windings are identical to the relationships found in a conventional single-phase power transformer. This means that the values of the line voltages and currents at the secondary are equal to those of the line voltages and currents at the primary (neglecting transformer losses). Also, the line voltage sine waves at the secondary are in phase with the line voltage sine waves at the primary. The same is true for the line current sine waves at the secondary with respect to the line current sine waves at the primary.

Wye-delta configuration

When a three-phase transformer bank is connected in a wye-delta configuration, the values and phases of the line voltages and currents at the secondary are different from those at the primary. Thus, in a wye-delta configuration, the value of the line voltages at the secondary is equal to that of the line voltages at the primary divided by $\sqrt{3}$. Conversely, the value of the line currents at the secondary is equal to that of the line currents at the primary multiplied by $\sqrt{3}$. Furthermore, the line voltage sine waves at the secondary lag behind those at the primary by 30° . The same is true for the line current sine waves at the secondary with respect to the line current sine waves at the primary.

Delta-wye configuration

When a three-phase transformer bank is connected in a delta-wye configuration, the values and phases of the line voltages and currents at the secondary are different from those at the primary. Thus, in a delta-wye configuration, the value of the line voltages at the secondary is equal to that of the line voltages at the primary multiplied by $\sqrt{3}$. Conversely, the value of the line currents at the secondary is equal to that of the line currents at the primary divided by $\sqrt{3}$. Furthermore, the line voltage sine waves at the secondary lead those at the primary by 30° . The same is true for the line current sine waves at the secondary with respect to the line current sine waves at the primary.

Summary of the characteristics of the four common three-phase transformer configurations

The following table gives a summary of the different characteristics of the four three-phase transformer configurations presented in the previous section (i.e., the wye-wye, delta-delta, wye-delta, and delta-wye configurations).

Table 1. Summary of the characteristics of three-phase transformer configurations.

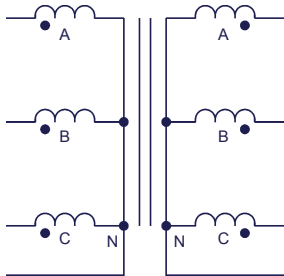
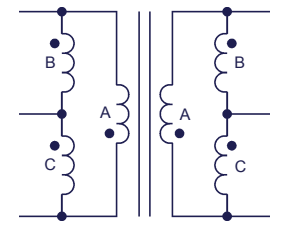
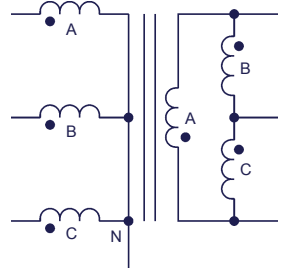
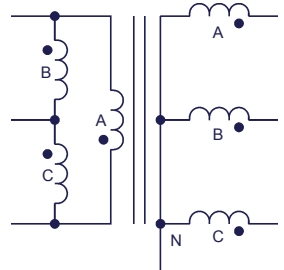
Three-phase transformer configuration	Line voltage relationship ($E_{Pri.}:E_{Sec.}$)	Line current relationship ($I_{Pri.}:I_{Sec.}$)	Phase shift (Sec. with respect to Pri.)	Number of wires (Pri.:Sec.)
 <p>Wye-wye configuration</p>	1:1	1:1	0°	4:4
 <p>Delta-delta configuration</p>	1:1	1:1	0°	3:3
 <p>Wye-delta configuration</p>	$\sqrt{3}:1$	$1:\sqrt{3}$	-30° (30° lag)	4:3
 <p>Delta-wye configuration</p>	$1:\sqrt{3}$	$\sqrt{3}:1$	30° (30° lead)	3:4

Remember that the line voltage and current relationships presented in Table 1 are valid only when the turns ratio of the transformers in the three-phase transformer bank is equal to 1:1. When the turns ratio of the transformers in the three-phase transformer bank is not 1:1, the actual line voltages at the secondary can be found by multiplying the primary line voltages by the voltage ratio appropriate to the configuration of the three-phase transformer bank and the inverse of the turns ratio ($N_{Sec.}/N_{Pri.}$) of the transformers. Similarly, the actual line currents at the secondary can be found by multiplying the primary line currents

by the current ratio appropriate to the configuration of the three-phase transformer bank and the turns ratio ($N_{Pri.}/N_{Sec.}$) of the transformers.

Uses of three-phase transformer banks

Three-phase transformer banks are used in three-phase ac power circuits for basically the same reasons as single-phase power transformers in single-phase ac circuits, i.e., to step-up or step-down the voltages in the circuit and to provide electrical isolation between the primary windings and the secondary windings. However, the special properties of certain three-phase transformer configurations presented in the previous sections allow three-phase transformer banks to be used in a few additional applications. The primary uses of three-phase transformer banks in three-phase ac power circuits are summarized below.

1. Three-phase transformer banks allow the voltages in the three-phase ac power circuit to be stepped-up (i.e., to be increased) or stepped-down (i.e., to be decreased).
2. Three-phase transformer banks provide electrical isolation between the primary windings and the secondary windings.
3. Three-phase transformer banks connected in a wye-delta or in a delta-wye configuration allow the number of wires in the three-phase ac power circuit to be decreased from 4 to 3, or increased from 3 to 4, respectively.
4. Three-phase transformer banks connected in a wye-delta or in a delta-wye configuration allow the incoming line voltages and currents to be phase shifted -30° or 30° , respectively.

PROCEDURE OUTLINE

The Procedure is divided into the following sections:

- Set up and connections
- Voltage, current, and phase relationships in a wye-wye configuration
- Voltage, current, and phase relationships in a wye-delta configuration
- Voltage, current, and phase relationships in a delta-delta configuration
- Voltage, current, and phase relationships in a delta-wye configuration

PROCEDURE

WARNING



High voltages are present in this laboratory exercise. Do not make or modify any banana jack connections with the power on unless otherwise specified.

Set up and connections

In this section, you will set up a circuit containing a three-phase transformer bank connected in a wye-wye configuration. You will then set the measuring equipment required to study the voltage, current, and phase relationships of the three-phase transformer bank.

1. Refer to the Equipment Utilization Chart in Appendix A to obtain the list of equipment required to perform this exercise.

Install the required equipment in the *Workstation*.

2. Make sure that the ac and dc power switches on the *Power Supply* are set to the *O* (off) position, then connect the *Power Supply* to a three-phase ac power outlet.

Connect the *Power Input* of the *Data Acquisition and Control Interface* to a 24 V ac power supply. Turn the 24 V ac power supply on.

3. Connect the USB port of the *Data Acquisition and Control Interface* to a USB port of the host computer.

4. Turn the host computer on, then start the *LVDAC-EMS* software.

In the *Module Selector* window, make sure that the *Data Acquisition and Control Interface* is detected. Make sure that the *Computer-Based Instrumentation* function for the *Data Acquisition and Control Interface* is selected. Also, select the network voltage and frequency that correspond to the voltage and frequency of your local ac power network, then click the *OK* button to close the *Module Selector* window.

5. Connect the equipment as shown in Figure 4.

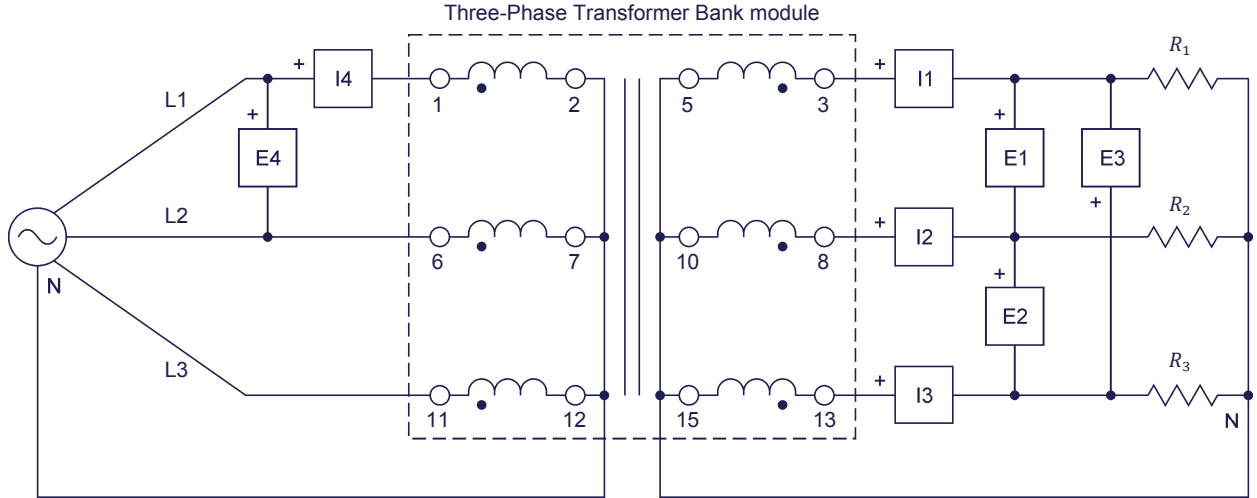

Local ac power network		R_1, R_2, R_3 (Ω)
Voltage (V)	Frequency (Hz)	
120	60	171
220	50	629
240	50	686

Figure 4. Three-phase transformer bank connected in a wye-wye configuration.



The values of the resistive loads used in the circuits of this manual depend on your local ac power network voltage and frequency. Whenever necessary, a table below the circuit diagram indicates the resistance of each load resistor for ac power network voltages of 120 V, 220 V, and 240 V, and for ac power network frequencies of 50 Hz and 60 Hz. Make sure to use the component values corresponding to your local ac power network voltage and frequency.

6. Make the necessary switch settings on the **Resistive Load** in order to obtain the resistance value required.



Appendix C lists the switch settings required on the **Resistive Load** in order to obtain various resistance values.

7. In the **Metering** window, make the required settings in order to measure the rms values (ac) of the line voltages $E_{Sec.1}$, $E_{Sec.2}$, and $E_{Sec.3}$ (inputs **E1**, **E2**, and **E3**, respectively), and the line currents $I_{Sec.1}$, $I_{Sec.2}$, and $I_{Sec.3}$ (inputs **I1**, **I2**, and **I3**, respectively) at the secondary of the three-phase transformer bank. Set two other meters to measure the line voltage $E_{Pri.}$ and current $I_{Pri.}$ at the primary of the three-phase transformer bank (inputs **E4** and **I4**, respectively).

Voltage, current, and phase relationships in a wye-wye configuration

In this section, you will measure the line voltages and currents at the secondary of the three-phase transformer bank, as well as a line voltage and current at the primary. Using the measured values, you will determine the voltage and current relationships between the primary and secondary windings of the three-phase transformer bank. You will then open the Phasor Analyzer and the Oscilloscope, and use both instruments to determine the phase shift between the line voltages at the secondary and the line voltages at the primary. Finally, you will confirm that the voltage, current, and phase relationships measured when the three-phase transformer bank is connected in a wye-wye configuration are coherent with the theory presented in the exercise discussion.

8. On the **Power Supply**, turn the three-phase ac power source on.

9. In the **Metering** window, measure the line voltages $E_{Sec.1}$, $E_{Sec.2}$, and $E_{Sec.3}$ at the secondary of the three-phase transformer bank, as well as the line voltage $E_{Pri.}$ at the primary. Also, measure the line currents $I_{Sec.1}$, $I_{Sec.2}$, and $I_{Sec.3}$ at the secondary of the three-phase transformer bank, as well as the line current $I_{Pri.}$ at the primary. Record all values below.

$E_{Sec.1} = \underline{\hspace{2cm}} \text{ V}$	$I_{Sec.1} = \underline{\hspace{2cm}} \text{ A}$
$E_{Sec.2} = \underline{\hspace{2cm}} \text{ V}$	$I_{Sec.2} = \underline{\hspace{2cm}} \text{ A}$
$E_{Sec.3} = \underline{\hspace{2cm}} \text{ V}$	$I_{Sec.3} = \underline{\hspace{2cm}} \text{ A}$
$E_{Pri.} = \underline{\hspace{2cm}} \text{ V}$	$I_{Pri.} = \underline{\hspace{2cm}} \text{ A}$

10. Using the line voltage and current values you measured in the previous step, determine the voltage and current relationships between the primary windings and the secondary windings of the three-phase transformer bank when it is connected in a wye-wye configuration.

Voltage relationship ($E_{Pri.}:E_{Sec.}$) = ___ : ___

Current relationship ($I_{Pri.}:I_{Sec.}$) = ___ : ___

11. In **LVDAC-EMS**, open the **Phasor Analyzer** and make the required settings to observe the phasors of the line voltages $E_{Sec.1}$, $E_{Sec.2}$, and $E_{Sec.3}$ at the secondary (inputs **E1**, **E2**, and **E3**, respectively), as well as the line voltage $E_{Pri.}$ at the primary of the three-phase transformer bank (input **E4**). Set the phasor of the line voltage $E_{Pri.}$ (input **E4**) at the primary as the reference phasor.

Using the **Phasor Analyzer**, determine the phase shift between the line voltage $E_{Sec.1}$ at the secondary and the line voltage $E_{Pri.}$ at the primary of the three-phase transformer bank.

Phase shift between $E_{Sec.1}$ and $E_{Pri.}$ = _____ °

12. In LVDAC-EMS, open the Oscilloscope and make the required settings to observe the waveforms of the line voltages $E_{Sec.1}$, $E_{Sec.2}$, and $E_{Sec.3}$ at the secondary (inputs E1, E2, and E3, respectively), as well as the line voltage $E_{Pri.}$ at the primary of the three-phase transformer bank (input E4).

Using the Oscilloscope, determine the phase shift between the line voltage $E_{Sec.1}$ at the secondary and the line voltage $E_{Pri.}$ at the primary of the three-phase transformer bank.

Phase shift between $E_{Sec.1}$ and $E_{Pri.}$ = _____°

Does the phase shift between the line voltage $E_{Sec.1}$ at the secondary and the line voltage $E_{Pri.}$ at the primary you just determined confirm the phase shift you obtained previously using the Phasor Analyzer?

Yes No

13. Are the voltage, current, and phase relationships you determined for the three-phase transformer bank connected in a wye-wye configuration coherent with the theory presented in the exercise discussion?

Yes No

14. On the Power Supply, turn the three-phase ac power source off.

Voltage, current, and phase relationships in a wye-delta configuration

In this section, you will connect the three-phase transformer bank in a wye-delta configuration. You will measure the line voltages and currents at the secondary of the three-phase transformer bank, as well as a line voltage and current at the primary. Using the measured values, you will determine the voltage and current relationships between the primary and secondary windings of the three-phase transformer bank. You will then use the Phasor Analyzer and the Oscilloscope to determine the phase shift between the line voltages at the secondary and the line voltages at the primary. Finally, you will confirm that the voltage, current, and phase relationships measured when the three-phase transformer bank is connected in a wye-delta configuration are coherent with the theory presented in the exercise discussion.

15. Connect the equipment as shown in Figure 5. In this circuit, only the connections at the secondary windings of the three-phase transformer bank have been modified with respect to the circuit used in the previous section.

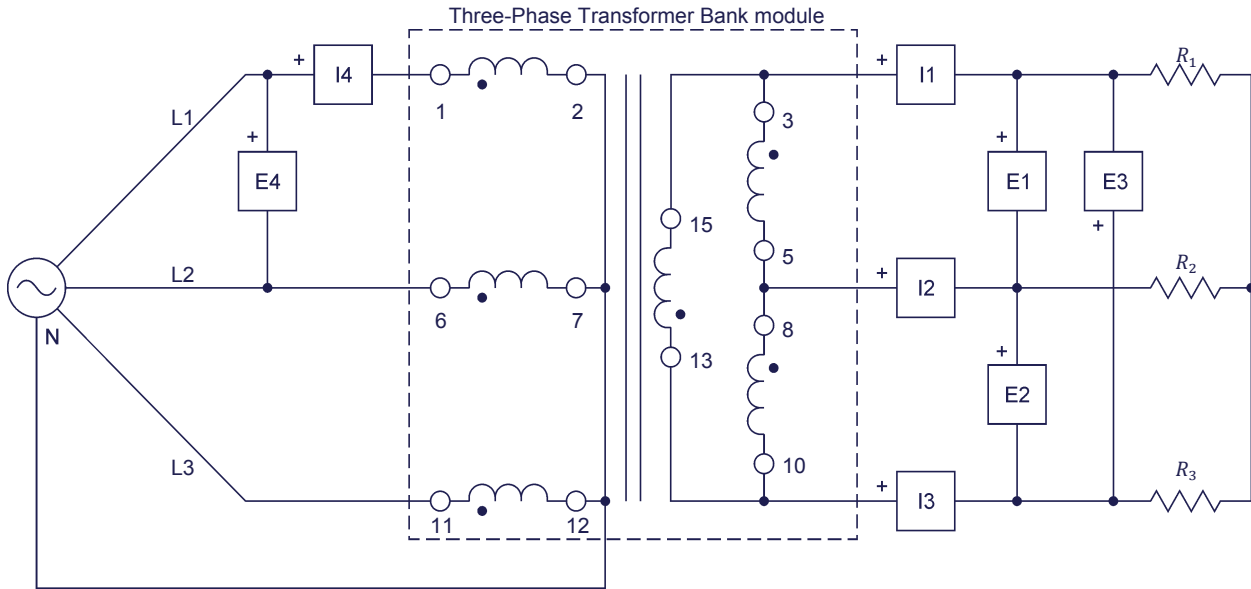

Local ac power network		R_1, R_2, R_3 (Ω)
Voltage (V)	Frequency (Hz)	
120	60	171
220	50	629
240	50	686

Figure 5. Three-phase transformer bank connected in a wye-delta configuration.

16. On the **Power Supply**, turn the three-phase ac power source on.
17. In the **Metering** window, measure the line voltages $E_{Sec.1}$, $E_{Sec.2}$, and $E_{Sec.3}$ at the secondary of the three-phase transformer bank, as well as the line voltage $E_{Pri.}$ at the primary. Also, measure the line currents $I_{Sec.1}$, $I_{Sec.2}$, and $I_{Sec.3}$ at the secondary of the three-phase transformer bank, as well as the line current $I_{Pri.}$ at the primary. Record all values below.

$$E_{Sec.1} = \text{_____ V} \qquad I_{Sec.1} = \text{_____ A}$$

$$E_{Sec.2} = \text{_____ V} \qquad I_{Sec.2} = \text{_____ A}$$

$$E_{Sec.3} = \text{_____ V} \qquad I_{Sec.3} = \text{_____ A}$$

$$E_{Pri.} = \text{_____ V} \qquad I_{Pri.} = \text{_____ A}$$

18. Using the line voltage and current values you measured in the previous step, determine the voltage and current relationships between the primary and the secondary windings of the three-phase transformer bank when it is connected in a wye-delta configuration.

Voltage relationship ($E_{Pri.}:E_{Sec.}$) = ____: ____

Current r relationship ($I_{Pri.}:I_{Sec.}$) = ____: ____

19. Using the **Phasor Analyzer** and the **Oscilloscope**, determine the phase shift between the line voltage $E_{Sec.1}$ at the secondary and the line voltage $E_{Pri.}$ at the primary of the three-phase transformer bank.

Phase shift between $E_{Sec.1}$ and $E_{Pri.}$ = _____°

20. Are the voltage, current, and phase relationships you determined for the three-phase transformer bank connected in a wye-delta configuration coherent with the theory presented in the exercise discussion?

Yes No

21. On the **Power Supply**, turn the three-phase ac power source off.

Voltage, current, and phase relationships in a delta-delta configuration

In this section, you will connect the three-phase transformer bank in a delta-delta configuration. You will measure the line voltages and currents at the secondary of the three-phase transformer bank, as well as a line voltage and current at the primary. Using the measured values, you will determine the voltage and current relationships between the primary and secondary windings of the three-phase transformer bank. You will then use the Phasor Analyzer and the Oscilloscope to determine the phase shift between the line voltages at the secondary and the line voltages at the primary. You will confirm that the voltage, current, and phase relationships measured when the three-phase transformer bank is connected in a delta-delta configuration are coherent with the theory presented in the exercise discussion. You will then reverse the connection of the windings at the secondary of the three-phase transformer bank. You will observe the resulting phase shift between the secondary and the primary line voltages using the Phasor Analyzer and the Oscilloscope, and analyze the results.

22. Connect the equipment as shown in Figure 6. In this circuit, only the connections at the primary windings of the three-phase transformer bank have been modified with respect to the circuit used in the previous section.

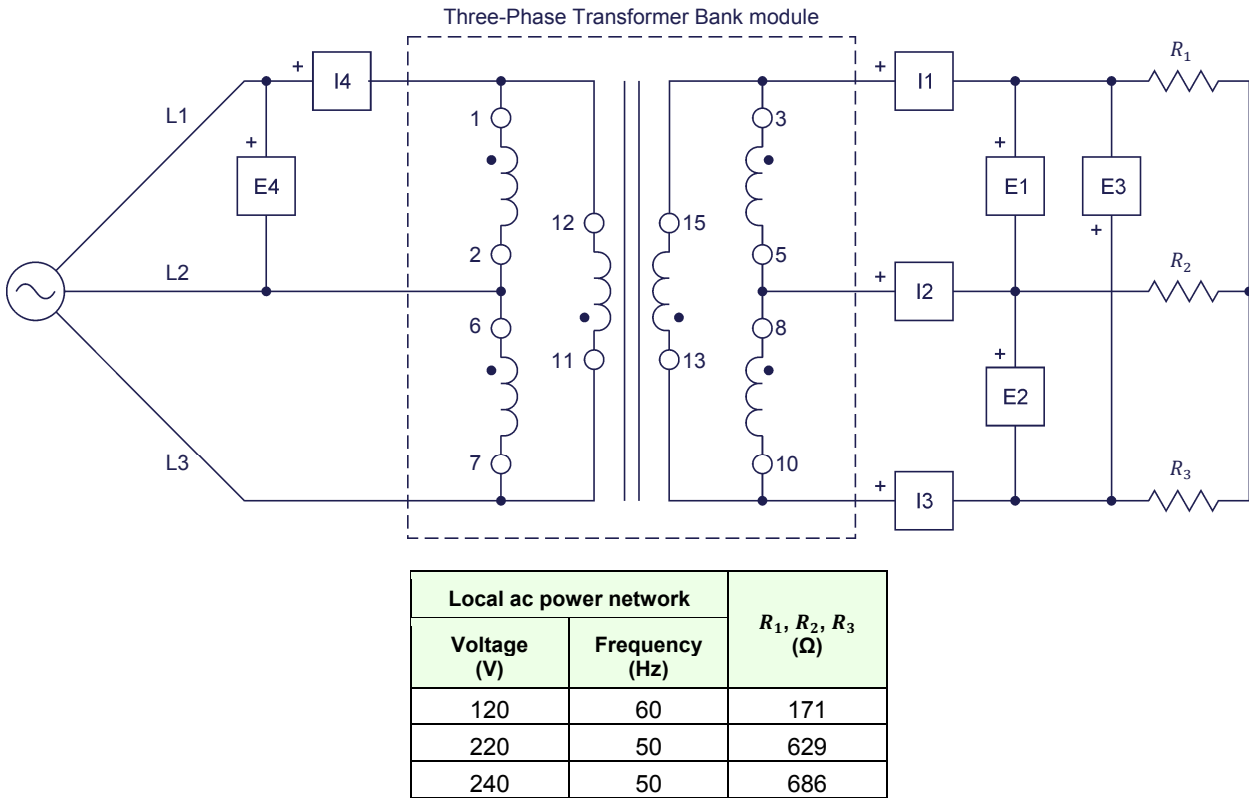

Figure 6. Three-phase transformer bank connected in a delta-delta configuration.

23. On the **Power Supply**, turn the three-phase ac power source on.
24. In the **Metering** window, measure the line voltages $E_{Sec.1}$, $E_{Sec.2}$, and $E_{Sec.3}$ at the secondary of the three-phase transformer bank, as well as the line voltage $E_{Pri.}$ at the primary. Also measure the line currents $I_{Sec.1}$, $I_{Sec.2}$, and $I_{Sec.3}$ at the secondary of the three-phase transformer bank, as well as the line current $I_{Pri.}$ at the primary. Record all values below.

$$E_{Sec.1} = \text{_____ V}$$

$$I_{Sec.1} = \text{_____ A}$$

$$E_{Sec.2} = \text{_____ V}$$

$$I_{Sec.2} = \text{_____ A}$$

$$E_{Sec.3} = \text{_____ V}$$

$$I_{Sec.3} = \text{_____ A}$$

$$E_{Pri.} = \text{_____ V}$$

$$I_{Pri.} = \text{_____ A}$$

25. Using the line voltage and current values you measured in the previous step, determine the voltage and current relationships between the primary and the

secondary of the three-phase transformer bank when it is connected in a delta-delta configuration.

Voltage relationship ($E_{Pri.}:E_{Sec.}$) = ____: ____

Current relationship ($I_{Pri.}:I_{Sec.}$) = ____: ____

26. Using the **Phasor Analyzer** and the **Oscilloscope**, determine the phase shift between the line voltage $E_{Sec.1}$ at the secondary and the line voltage $E_{Pri.}$ at the primary of the three-phase transformer bank.

Phase shift between $E_{Sec.1}$ and $E_{Pri.}$ = _____°

27. Are the voltage, current, and phase relationships you determined for the three-phase transformer bank connected in a delta-delta configuration coherent with the theory presented in the exercise discussion?

Yes No

28. On the **Power Supply**, turn the three-phase ac power source off.

29. Reverse the connections at each of the secondary windings of the three-phase transformer bank. The circuit should now be as shown in Figure 7.

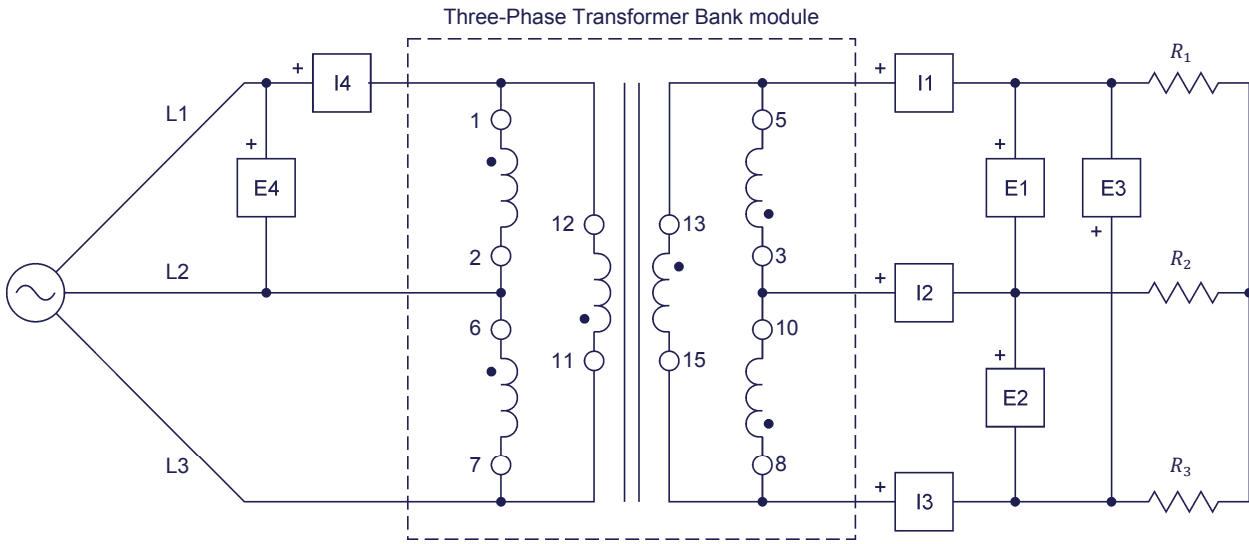

Local ac power network		R_1, R_2, R_3 (Ω)
Voltage (V)	Frequency (Hz)	
120	60	171
220	50	629
240	50	686

Figure 7. Three-phase transformer bank connected in a delta-delta configuration with reversed connections at the secondary windings.

30. On the Power Supply, turn the three-phase ac power source on.
31. Using the Phasor Analyzer and the Oscilloscope, determine the phase shift between the line voltage $E_{Sec.1}$ at the secondary and the line voltage $E_{Pri.}$ at the primary of the three-phase transformer bank.

Phase shift between $E_{Sec.1}$ and $E_{Pri.}$ = _____°

32. What happens to the phase shift between the line voltage $E_{Sec.1}$ at the secondary and the line voltage $E_{Pri.}$ at the primary when the connections at the secondary windings of the three-phase transformer bank are reversed?

Do your results confirm that it is important to respect the winding polarity when connecting the windings of a three-phase transformer bank? Briefly explain why.

33. On the Power Supply, turn the three-phase ac power source off.

Voltage, current, and phase relationships in a delta-wye configuration

In this section, you will connect the three-phase transformer bank in a delta-wye configuration. You will measure the line voltages and currents at the secondary of the three-phase transformer bank, as well as a line voltage and current at the primary. Using the measured values, you will determine the voltage and current relationships between the primary and secondary windings of the three-phase transformer bank. You will then use the Phasor Analyzer and the Oscilloscope to determine the phase shift between the line voltages at the secondary and the line voltages at the primary. Finally, you will confirm that the voltage, current, and phase relationships measured when the three-phase transformer bank is connected in a delta-wye configuration are coherent with the theory presented in the exercise discussion. You will then reverse the connections of the windings at the secondary of the three-phase transformer bank. You will observe the resulting phase shift between the secondary and the primary line voltages using the Phasor Analyzer and the Oscilloscope, and analyze the results.

34. Connect the equipment as shown in Figure 8. In this circuit, only the connections at the secondary windings of the three-phase transformer bank have been modified with respect to the last circuit used in the previous section.

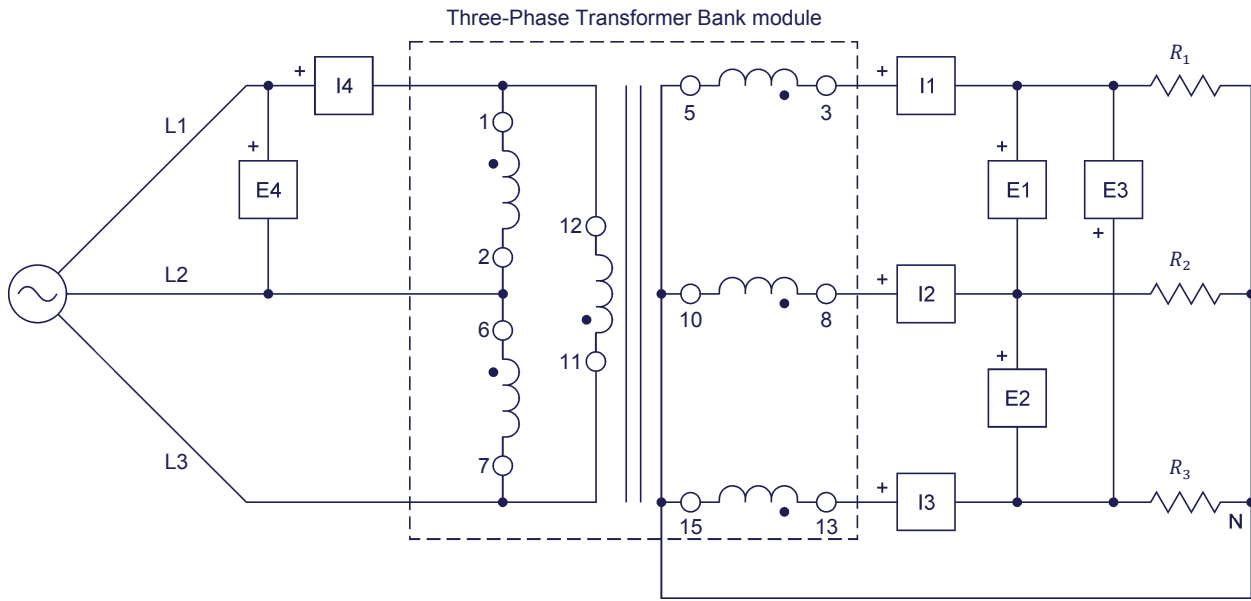

Local ac power network		R_1, R_2, R_3 (Ω)
Voltage (V)	Frequency (Hz)	
120	60	300
220	50	1100
240	50	1200

Figure 8. Three-phase transformer bank connected in a delta-wye configuration.

35. Make the necessary switch settings on the **Resistive Load** in order to obtain the resistance value required.

36. On the Power Supply, turn the three-phase ac power source on.

CAUTION

The voltage and power ratings of the Resistive Load are significantly exceeded in this manipulation. It is therefore important that you perform the remainder of this step in less than 2 minutes to avoid damaging the Resistive Load.

In the Metering window, measure the line voltages $E_{Sec.1}$, $E_{Sec.2}$, and $E_{Sec.3}$ at the secondary of the three-phase transformer bank, as well as the line voltage $E_{Pri.}$ at the primary. Also measure the line currents $I_{Sec.1}$, $I_{Sec.2}$, and $I_{Sec.3}$ at the secondary of the three-phase transformer bank, as well as the line current $I_{Pri.}$ at the primary. Record all values below.

$E_{Sec.1} = \underline{\hspace{2cm}} \text{ V}$	$I_{Sec.1} = \underline{\hspace{2cm}} \text{ A}$
$E_{Sec.2} = \underline{\hspace{2cm}} \text{ V}$	$I_{Sec.2} = \underline{\hspace{2cm}} \text{ A}$
$E_{Sec.3} = \underline{\hspace{2cm}} \text{ V}$	$I_{Sec.3} = \underline{\hspace{2cm}} \text{ A}$
$E_{Pri.} = \underline{\hspace{2cm}} \text{ V}$	$I_{Pri.} = \underline{\hspace{2cm}} \text{ A}$

On the Power Supply, turn the three-phase ac power source off.

37. Using the line voltage and current values you recorded in the previous step, determine the voltage and current relationships between the primary and the secondary of the three-phase transformer bank connected in a delta-wye configuration.

Voltage relationship ($E_{Pri.}:E_{Sec.}$) = ____: ____

Current relationship ($I_{Pri.}:I_{Sec.}$) = ____: ____

38. On the Power Supply, turn the three-phase ac power source on.

CAUTION

The voltage and power ratings of the Resistive Load are significantly exceeded in this manipulation. It is therefore important that you perform the remainder of this step in less than 2 minutes to avoid damaging the Resistive Load.

Using the Phasor Analyzer and the Oscilloscope, determine the phase shift between the line voltage $E_{Sec.1}$ at the secondary and the line voltage $E_{Pri.}$ at the primary of the three-phase transformer bank.

Phase shift between $E_{Sec.1}$ and $E_{Pri.} = \underline{\hspace{2cm}}^\circ$

On the Power Supply, turn the three-phase ac power source off.

39. Are the voltage, current, and phase relationships you determined for the three-phase transformer bank connected in a delta-wye configuration coherent with the theory presented in the exercise discussion?

Yes No

40. Reverse the connections at each of the secondary windings of the three-phase transformer bank. The circuit should now be as shown in Figure 9.

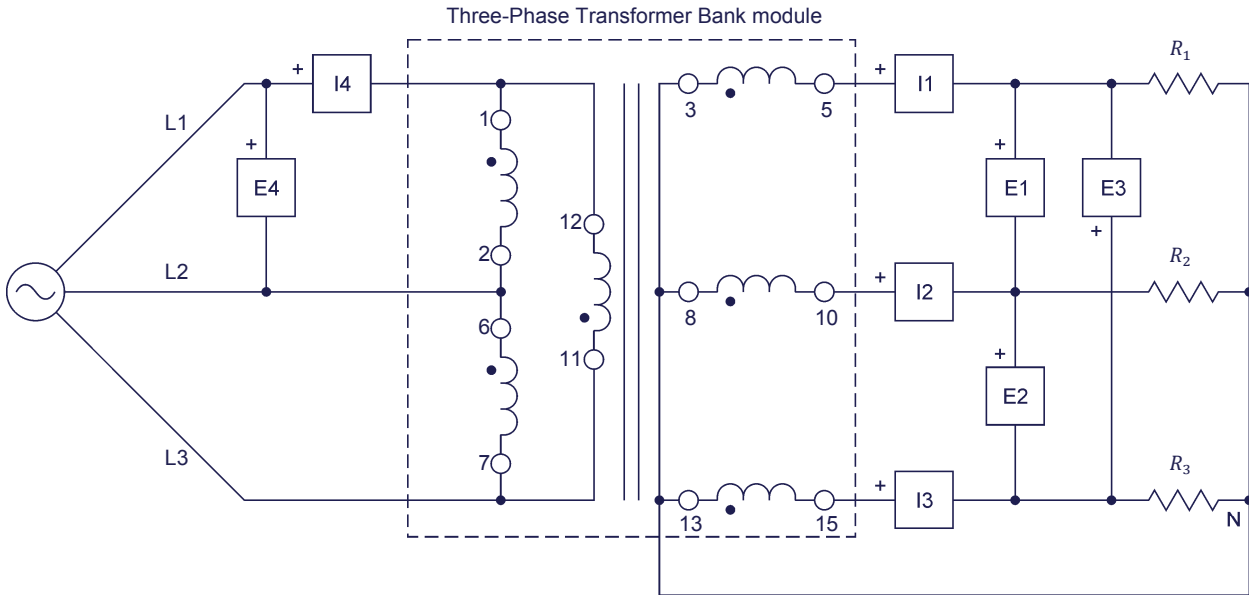

Local ac power network		R_1, R_2, R_3 (Ω)
Voltage (V)	Frequency (Hz)	
120	60	300
220	50	1100
240	50	1200

Figure 9. Three-phase transformer bank connected in a delta-wye configuration with reversed connections at the secondary windings.

41. On the Power Supply, turn the three-phase ac power source on.

CAUTION

The voltage and power ratings of the Resistive Load are significantly exceeded in this manipulation. It is therefore important that you perform the remainder of this step in less than 2 minutes to avoid damaging the Resistive Load.

Using the Phasor Analyzer and the Oscilloscope, determine the phase shift between the line voltage $E_{Sec.1}$ at the secondary and the line voltage $E_{Pri.}$ at the primary of the three-phase transformer bank.

Phase shift between $E_{Sec.1}$ and $E_{Pri.}$ = _____°

On the Power Supply, turn the three-phase ac power source off.

42. What happens to the phase shift between the line voltage $E_{Sec.1}$ at the secondary and the line voltage $E_{Pri.}$ at the primary when the connections at the secondary windings of the three-phase transformer bank are reversed?

Is the effect of reversing the connections at the secondary windings of the three-phase transformer bank connected in a delta-wye configuration similar to what you observed in step 31 when the three-phase transformer bank is connected in a delta-delta configuration?

- Yes No

43. Close LVDAC-EMS, then turn off all the equipment. Disconnect all leads and return them to their storage location.

CONCLUSION

In this exercise, you learned how to connect three-phase transformer banks in wye-wye, delta-delta, wye-delta, and delta-wye configurations. You also determined the voltage, current, and phase relationships between the primary windings and the secondary windings of a three-phase transformer bank for each of these configurations. You saw the uses of three-phase transformer banks in three-phase ac power circuits.

REVIEW QUESTIONS

1. What are the main differences between single-unit, three-phase power transformers and three-phase transformer banks?

2. How is it possible to confirm that the wye-connected secondary windings of a three-phase transformer bank are properly connected (i.e., that winding polarity is respected)? Explain briefly.

3. How is it possible to confirm that the delta-connected secondary windings of a three-phase transformer bank are properly connected (i.e., that winding polarity is respected) before closing the delta? Explain briefly.

4. Consider a three-phase transformer bank connected in a delta-wye configuration. Each winding at the primary of the three-phase transformer bank is made of 800 turns of wire, while each winding at the secondary is made of 1340 turns of wire. Knowing that the line voltage $E_{Pri.}$ at the primary is equal to 208 V, determine the line voltage $E_{Sec.}$ at the secondary.

5. Consider a three-phase transformer bank connected in a wye-delta configuration. Each winding at the primary of the three-phase transformer bank is made of 4800 turns of wire, while each winding at the secondary is made of 1600 turns of wire. Knowing that the line voltage $E_{Pri.}$ at the primary is equal to 75 kV, determine the line voltage $E_{Sec.}$ at the secondary.

Sample
Extracted from
Instructor Guide

Exercise 1 Three-Phase Transformer Configurations

ANSWERS TO PROCEDURE STEP QUESTIONS

9. $E_{Sec.1} = 196 \text{ V}$	$I_{Sec.1} = 0.67 \text{ A}$
$E_{Sec.2} = 196 \text{ V}$	$I_{Sec.2} = 0.66 \text{ A}$
$E_{Sec.3} = 197 \text{ V}$	$I_{Sec.3} = 0.67 \text{ A}$
$E_{Pri.} = 205 \text{ V}$	$I_{Pri.} = 0.68 \text{ A}$

10. Voltage relationship ($E_{Pri.}:E_{Sec.}$) = 205 V:196 V = 1:0.96 (\cong 1:1)

Current relationship ($I_{Pri.}:I_{Sec.}$) = 0.68 A:0.67 A = 1:0.99 (\cong 1:1)



It is normal that the line voltages measured at the secondary to be slightly (about 5%) lower than expected. This is because the voltage regulation of the three-phase transformer bank is not ideal, thereby resulting in a voltage drop at the secondary. Due to this voltage drop, the line currents at the secondary are also proportionally lower.

11. The resulting phasors of the line voltages at the primary and the secondary of the three-phase transformer bank are shown in the following figure:

Phasor Analyzer Settings
 Reference Phasor..... E4
 Voltage Scale.....100 V/div

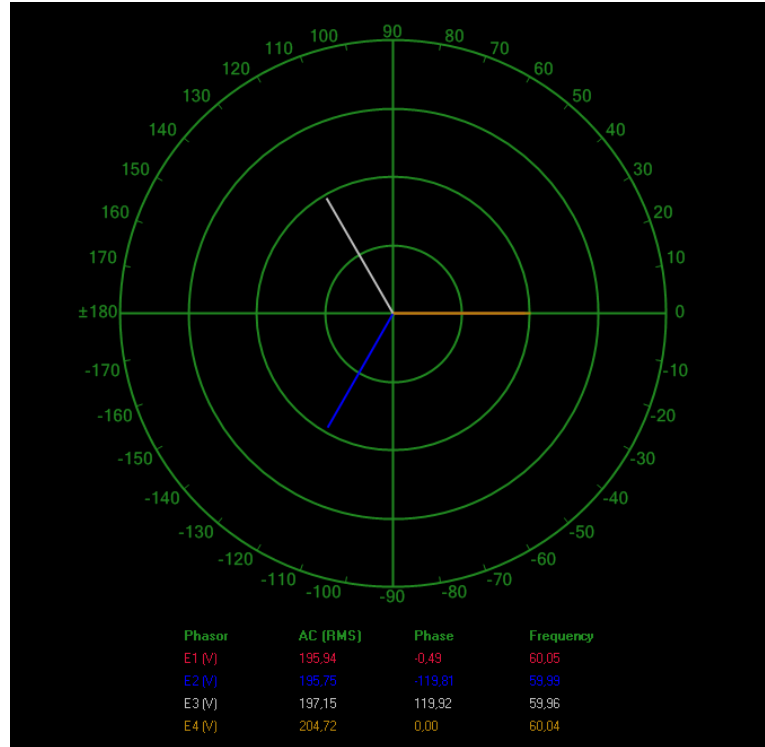

Phasors of the line voltages at the primary and the secondary of the three-phase transformer bank when it is connected in a wye-wye configuration.

Phase shift between $E_{Sec.1}$ and $E_{Pri.} = -0.49^\circ$

12. The resulting sine waves of the line voltages at the primary and the secondary of the three-phase transformer bank are shown in the following figure:

Oscilloscope Settings
 Channel-1 Input E1
 Channel-1 Scale 200 V/div
 Channel-1 Coupling DC
 Channel-2 Input E2
 Channel-2 Scale 200 V/div
 Channel-2 Coupling DC
 Channel-3 Input E3
 Channel-3 Scale 200 V/div
 Channel-3 Coupling DC
 Channel-4 Input E4
 Channel-4 Scale 200 V/div
 Channel-4 Coupling DC
 Trigger Type Software
 Time Base 5 ms/div
 Trigger Source Ch1
 Trigger Level 0
 Trigger Slope Rising

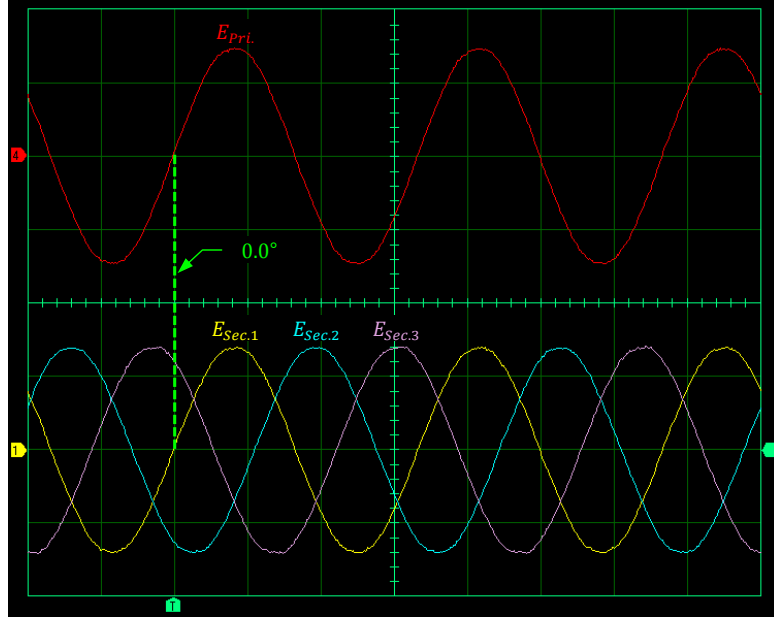

Sine waves of the line voltages at the primary and the secondary of the three-phase transformer bank when it is connected in a wye-wye configuration.

Phase shift between $E_{Sec.1}$ and $E_{Pri.} = 0.0^\circ$

Yes

13. Yes

- | | |
|---------------------------------|------------------------------|
| 17. $E_{Sec.1} = 118 \text{ V}$ | $I_{Sec.1} = 0.40 \text{ A}$ |
| $E_{Sec.2} = 116 \text{ V}$ | $I_{Sec.2} = 0.40 \text{ A}$ |
| $E_{Sec.3} = 117 \text{ V}$ | $I_{Sec.3} = 0.40 \text{ A}$ |
| $E_{Pri.} = 206 \text{ V}$ | $I_{Pri.} = 0.24 \text{ A}$ |

18. Voltage relationship ($E_{Pri.}:E_{Sec.}$) = 206 V: 117 V = 1.76: 1 ($\cong \sqrt{3}: 1$)

Current relationship ($I_{Pri.}:I_{Sec.}$) = 0.24 A: 0.40 A = 1: 1.67 ($\cong 1:\sqrt{3}$)



It is normal for the line current measured at the primary to be slightly (about 5%) greater than expected. This is due to the magnetizing current flowing in the primary. In order to find the actual value of the primary current due to the flow of the secondary line current through the load, the value of the magnetizing current flowing in the primary would need to be vectorially subtracted from the measured primary current $I_{Pri.}$.

19. The resulting phasors of the line voltages at the primary and the secondary of the three-phase transformer bank are shown in the following figure:

Phasor Analyzer Settings
 Reference Phasor..... E4
 Voltage Scale..... 100 V/div

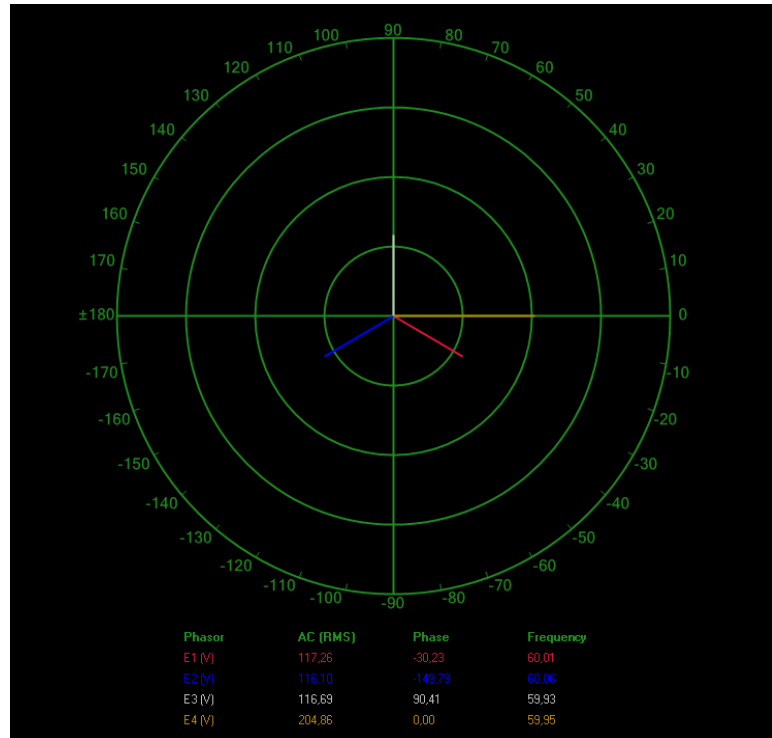

Phasors of the line voltages at the primary and the secondary of the three-phase transformer bank when it is connected in a wye-delta configuration.

The resulting sine waves of the line voltages at the primary and the secondary of the three-phase transformer bank are shown in the following figure:

Oscilloscope Settings
 Channel-1 Input E1
 Channel-1 Scale 200 V/div
 Channel-1 Coupling DC
 Channel-2 Input E2
 Channel-2 Scale 200 V/div
 Channel-2 Coupling DC
 Channel-3 Input E3
 Channel-3 Scale 200 V/div
 Channel-3 Coupling DC
 Channel-4 Input E4
 Channel-4 Scale 200 V/div
 Channel-4 Coupling DC
 Trigger Type Software
 Time Base 5 ms/div
 Trigger Source Ch1
 Trigger Level 0
 Trigger Slope Rising

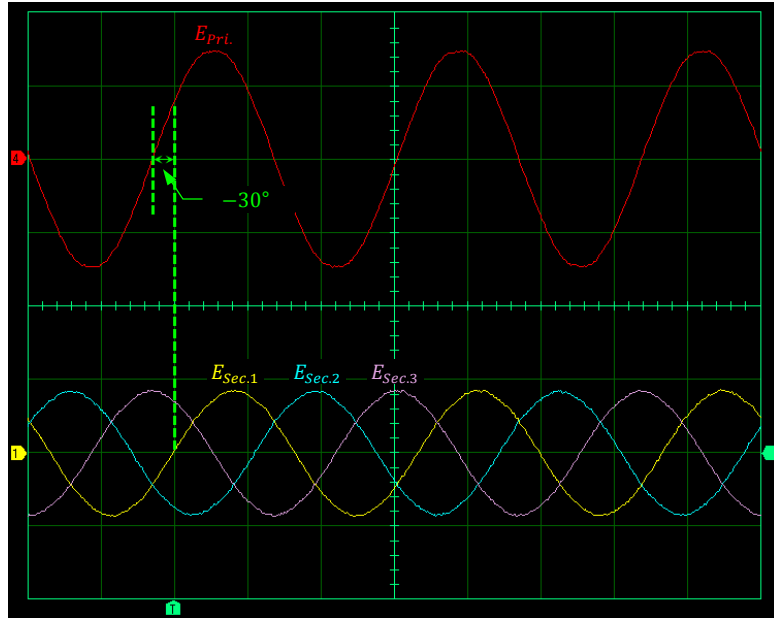

Sine waves of the line voltages at the primary and the secondary of the three-phase transformer bank when it is connected in a wye-delta configuration.

Phase shift between $E_{Sec.1}$ and $E_{Pri.} = -30.2^\circ$

20. Yes

- | | |
|--------------------------------|-----------------------------|
| 24. $E_{Sec.1} = 202\text{ V}$ | $I_{Sec.1} = 0.69\text{ A}$ |
| $E_{Sec.2} = 201\text{ V}$ | $I_{Sec.2} = 0.68\text{ A}$ |
| $E_{Sec.3} = 203\text{ V}$ | $I_{Sec.3} = 0.69\text{ A}$ |
| $E_{Pri.} = 205\text{ V}$ | $I_{Pri.} = 0.73\text{ A}$ |

25. Voltage relationship $(E_{Pri.}:E_{Sec.}) = 205\text{ V}:202\text{ V} = 1:0.99 (\cong 1:1)$

Current relationship $(I_{Pri.}:I_{Sec.}) = 0.73\text{ A}:0.69\text{ A} = 1:0.95 (\cong 1:1)$



It is normal for the line current measured at the primary to be slightly (about 5%) greater than expected. This is due to the magnetizing current flowing in the primary. In order to find the actual value of the primary current due to the flow of the secondary line current through the load, the value of the magnetizing current flowing in the primary would need to be vectorially subtracted from the measured primary current $I_{Pri.}$.

26. The resulting phasors of the line voltages at the primary and the secondary of the three-phase transformer bank are shown in the following figure:

Phasor Analyzer Settings
 Reference Phasor..... E4
 Voltage Scale.....100 V/div

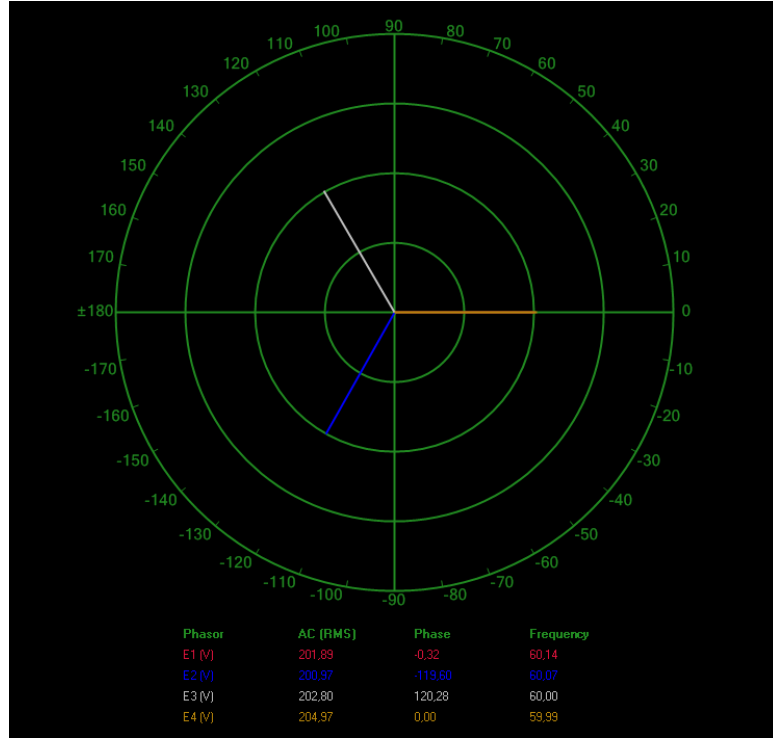

Phasors of the line voltages at the primary and the secondary of the three-phase transformer bank when it is connected in a delta-delta configuration.

The resulting sine waves of the line voltages at the primary and the secondary of the three-phase transformer bank are shown in the following figure:

Oscilloscope Settings
 Channel-1 Input E1
 Channel-1 Scale 200 V/div
 Channel-1 Coupling DC
 Channel-2 Input E2
 Channel-2 Scale 200 V/div
 Channel-2 Coupling DC
 Channel-3 Input E3
 Channel-3 Scale 200 V/div
 Channel-3 Coupling DC
 Channel-4 Input E4
 Channel-4 Scale 200 V/div
 Channel-4 Coupling DC
 Trigger Type Software
 Time Base 5 ms/div
 Trigger Source Ch1
 Trigger Level 0
 Trigger Slope Rising

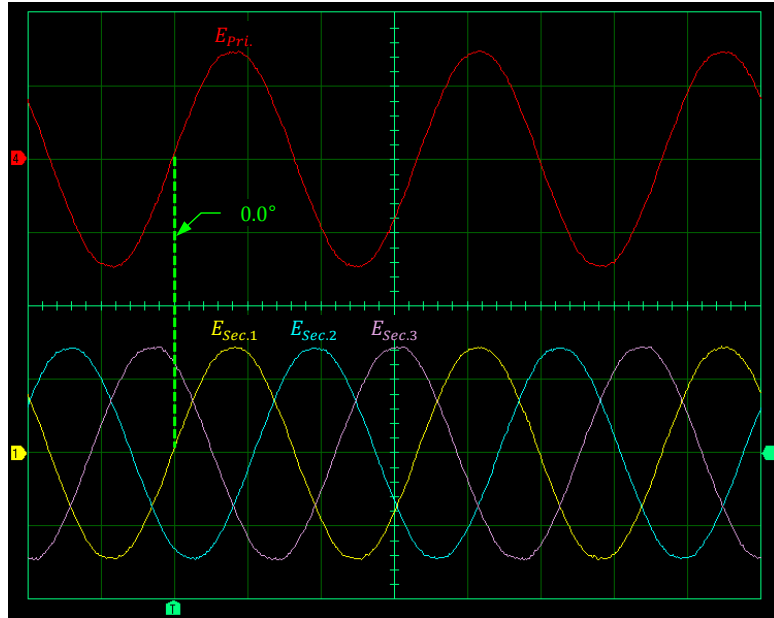

Sine waves of the line voltages at the primary and the secondary of the three-phase transformer bank when it is connected in a delta-delta configuration.

$$\text{Phase shift between } E_{Sec.1} \text{ and } E_{Pri.} = -0.32^\circ$$

27. Yes

31. The resulting phasors of the line voltages at the primary and the secondary of the three-phase transformer bank are shown in the following figure:

Phasor Analyzer Settings
 Reference Phasor..... E4
 Voltage Scale.....100 V/div

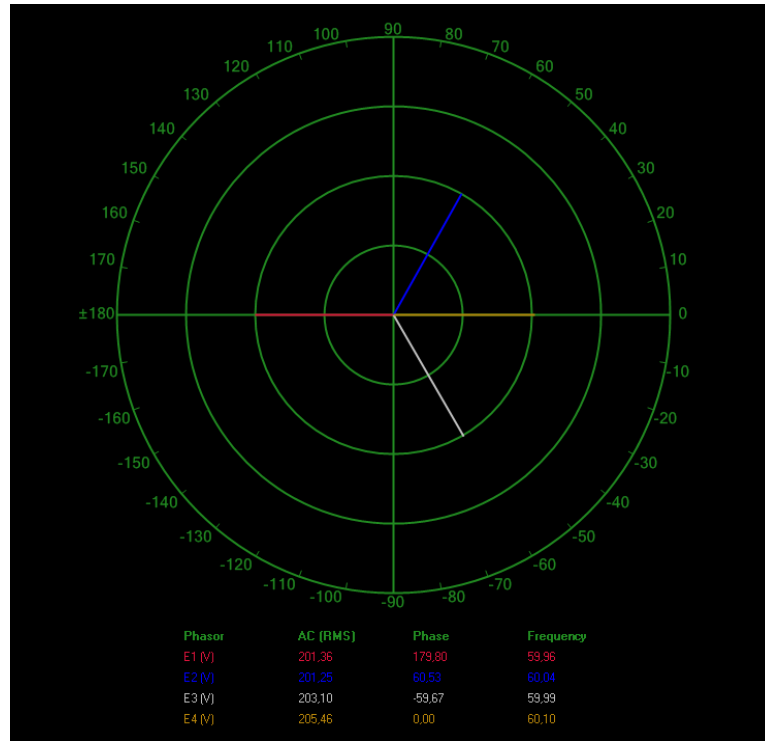

Phasors of the line voltages at the primary and the secondary of the three-phase transformer bank when it is connected in a delta-delta configuration with reversed connections at the secondary windings.

The resulting sine waves of the line voltages at the primary and the secondary of the three-phase transformer bank are shown in the following figure:

Oscilloscope Settings
 Channel-1 Input E1
 Channel-1 Scale 200 V/div
 Channel-1 Coupling DC
 Channel-2 Input E2
 Channel-2 Scale 200 V/div
 Channel-2 Coupling DC
 Channel-3 Input E3
 Channel-3 Scale 200 V/div
 Channel-3 Coupling DC
 Channel-4 Input E4
 Channel-4 Scale 200 V/div
 Channel-4 Coupling DC
 Trigger Type Software
 Time Base 5 ms/div
 Trigger Source Ch1
 Trigger Level 0
 Trigger Slope Rising

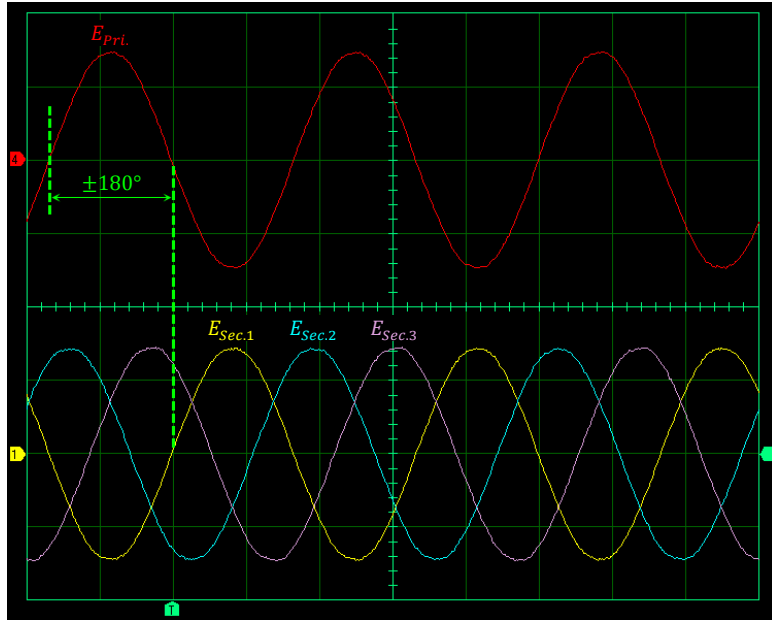

Sine waves of the line voltages at the primary and the secondary of the three-phase transformer bank when it is connected in a delta-delta configuration with reversed connections at the secondary windings.

Phase shift between $E_{Sec.1}$ and $E_{Pri.} = \pm 180^\circ$



The \pm sign in the above phase shift indicates that the secondary line voltage $E_{Sec.1}$ can be considered leading or lagging the primary line voltage $E_{Pri.}$ by 180° .

32. Reversing the connections at the secondary windings of the three-phase transformer bank introduces a 180° phase shift between the sine waves of the line voltage $E_{Sec.1}$ at the secondary and the line voltage $E_{Pri.}$ at the primary.

Yes, the results confirm that it is important to respect the winding polarity when connecting the windings of a three-phase transformer bank. Otherwise, the phase shift between the line voltages at the primary and the line voltages at the secondary significantly differs from what is expected.

- | | |
|---------------------------------|------------------------------|
| 36. $E_{Sec.1} = 343 \text{ V}$ | $I_{Sec.1} = 0.68 \text{ A}$ |
| $E_{Sec.2} = 345 \text{ V}$ | $I_{Sec.2} = 0.68 \text{ A}$ |
| $E_{Sec.3} = 346 \text{ V}$ | $I_{Sec.3} = 0.68 \text{ A}$ |
| $E_{Pri.} = 204 \text{ V}$ | $I_{Pri.} = 1.22 \text{ A}$ |

37. Voltage relationship ($E_{Pri.}:E_{Sec.}$) = 204 V: 345 V = 1: 1.69 ($\cong 1:\sqrt{3}$)

Current relationship ($I_{Pri.}:I_{Sec.}$) = 1.22 A: 0.68 A = 1.79: 1 ($\cong \sqrt{3}: 1$)



It is normal for the line current measured at the primary to be slightly (about 5%) greater than expected. This is due to the magnetizing current flowing in the primary. In order to find the actual value of the primary current due to the flow of the secondary line current through the load, the value of the magnetizing current flowing in the primary would need to be vectorially subtracted from the measured primary current $I_{Pri.}$.

38. The resulting phasors of the line voltages at the primary and the secondary of the three-phase transformer bank are shown in the following figure:

Phasor Analyzer Settings
 Reference Phasor..... E4
 Voltage Scale..... 100 V/div

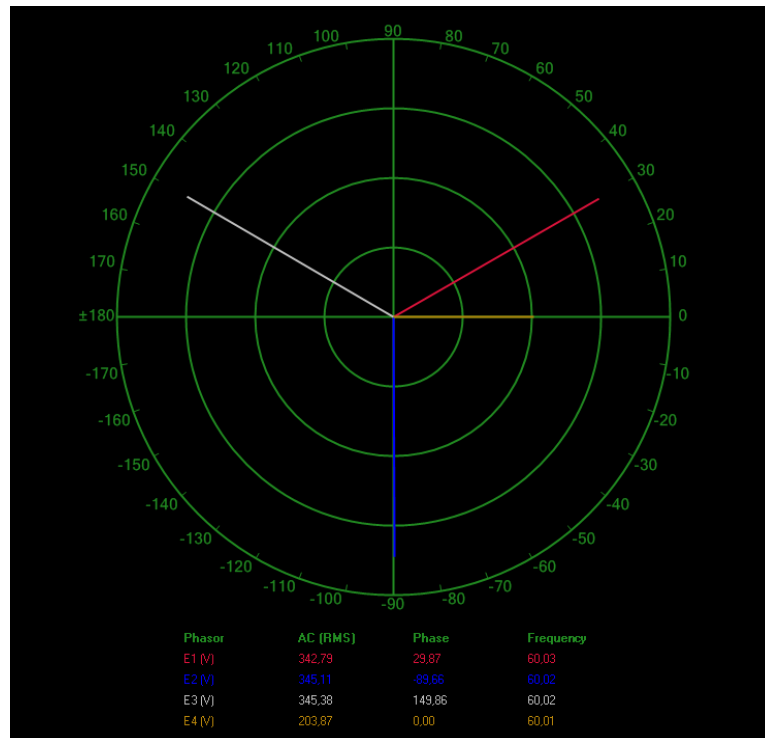

Phasors of the line voltages at the primary and the secondary of the three-phase transformer bank when it is connected in a delta-wye configuration.

The resulting sine waves of the line voltages at the primary and the secondary of the three-phase transformer bank are shown in the following figure:

Oscilloscope Settings
 Channel-1 Input E1
 Channel-1 Scale 200 V/div
 Channel-1 Coupling DC
 Channel-2 Input E2
 Channel-2 Scale 200 V/div
 Channel-2 Coupling DC
 Channel-3 Input E3
 Channel-3 Scale 200 V/div
 Channel-3 Coupling DC
 Channel-4 Input E4
 Channel-4 Scale 200 V/div
 Channel-4 Coupling DC
 Trigger Type Software
 Time Base 5 ms/div
 Trigger Source Ch1
 Trigger Level 0
 Trigger Slope Rising

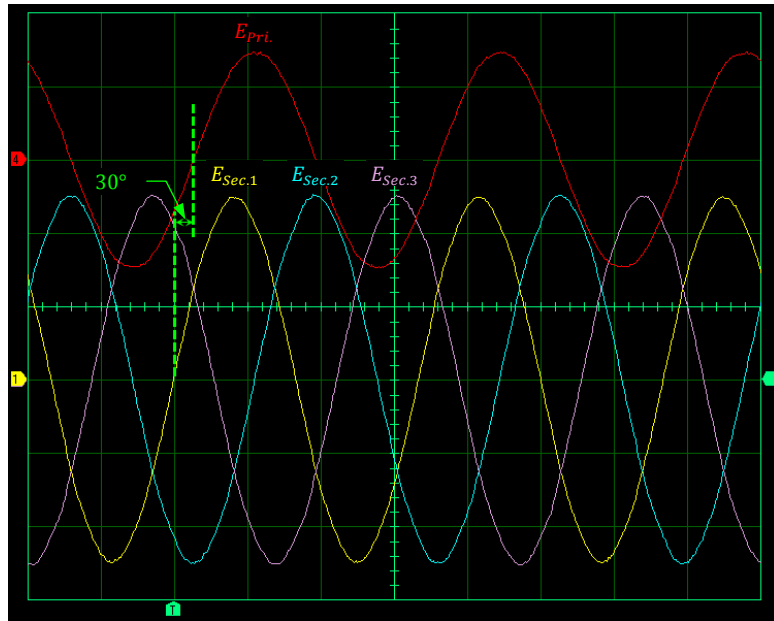

Sine waves of the line voltages at the primary and the secondary of the three-phase transformer bank when it is connected in a delta-wye configuration.

Phase shift between $E_{Sec.1}$ and $E_{Pri.} = 29.9^\circ$

39. Yes

41. The resulting phasors of the line voltages at the primary and the secondary of the three-phase transformer bank are shown in the following figure:

Phasor Analyzer Settings
 Reference Phasor..... E4
 Voltage Scale.....100 V/div

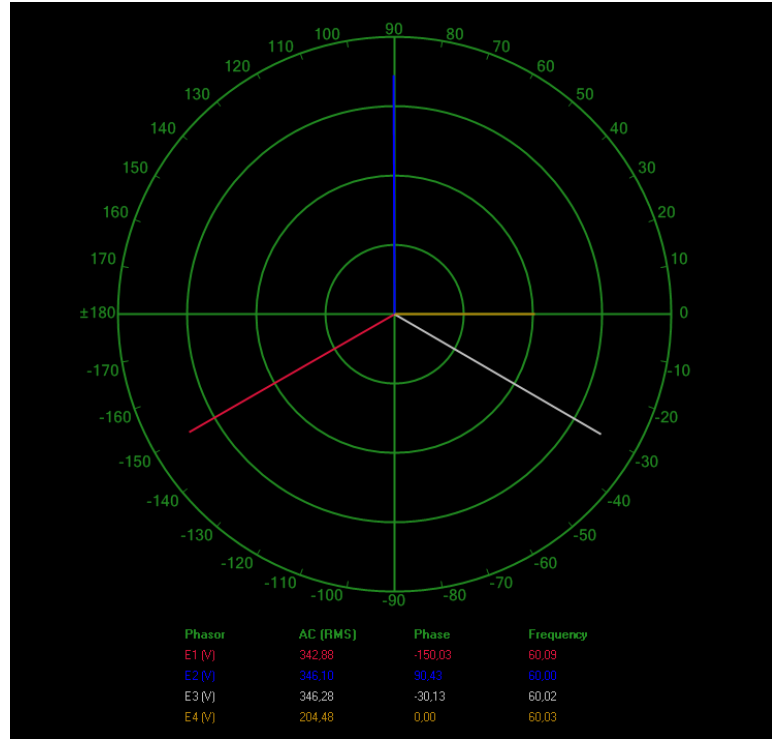

Phasors of the line voltages at the primary and the secondary of the three-phase transformer bank when it is connected in a delta-wye configuration with reversed connections at the secondary windings.

The resulting sine waves of the line voltages at the primary and the secondary of the three-phase transformer bank are shown in the following figure:

Oscilloscope Settings
 Channel-1 Input E1
 Channel-1 Scale 200 V/div
 Channel-1 Coupling DC
 Channel-2 Input E2
 Channel-2 Scale 200 V/div
 Channel-2 Coupling DC
 Channel-3 Input E3
 Channel-3 Scale 200 V/div
 Channel-3 Coupling DC
 Channel-4 Input E4
 Channel-4 Scale 200 V/div
 Channel-4 Coupling DC
 Trigger Type Software
 Time Base 5 ms/div
 Trigger Source Ch1
 Trigger Level 0
 Trigger Slope Rising

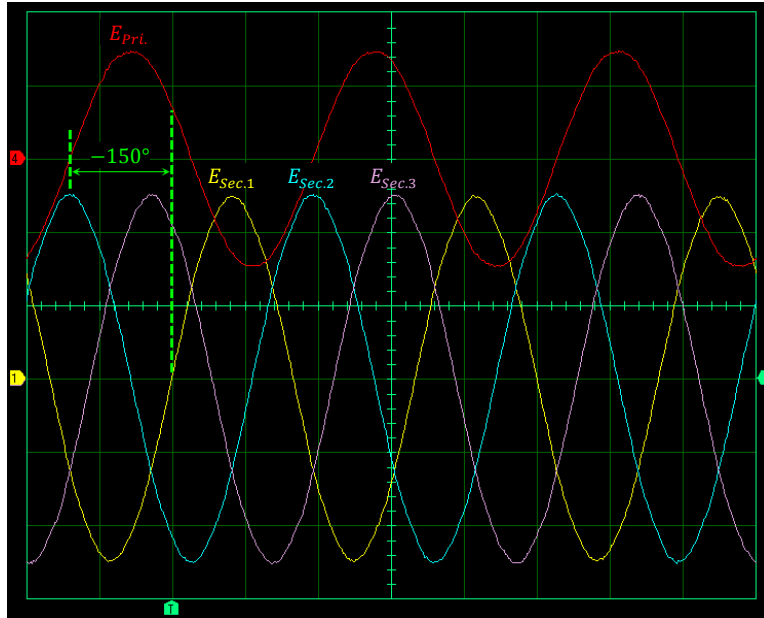

Sine waves of the line voltages at the primary and the secondary of the three-phase transformer bank when it is connected in a delta-wye configuration with reversed connections at the secondary windings.

Phase shift between $E_{Sec.1}$ and $E_{Pri.} = -150^\circ$

42. Reversing the connections at the secondary windings of the three-phase transformer bank introduces an additional 180° phase shift between the sine waves of the line voltage $E_{Sec.1}$ at the secondary and the line voltage $E_{Pri.}$ at the primary. The phase shift between the sine waves of the line voltage $E_{Sec.1}$ at the secondary and the line voltage $E_{Pri.}$ at the primary is thus modified from 29.9° to -150° .

Yes

ANSWERS TO REVIEW QUESTIONS

- Single-unit, three-phase power transformers are constructed by winding three single-phase power transformers around a single core. On the other hand, three-phase transformer banks consist of three individual single-phase power transformers that are grouped together. For a given power rating, single-unit, three-phase power transformers are smaller, require less material, and are less costly than three-phase transformer banks. However, three-phase transformer banks are easier to maintain.

2. It is possible to confirm that the wye-connected secondary windings of a three-phase transformer bank are properly connected by, firstly, confirming that the line voltage between any two windings is $\sqrt{3}$ times greater than the phase voltage across either of the two windings. Then, secondly, by confirming that the line voltage between the third winding and each of the other two windings is also $\sqrt{3}$ times greater than the phase voltage measured previously.
3. It is possible to confirm that the delta-connected secondary windings of a three-phase transformer bank are properly connected before closing the delta by, firstly, confirming that the voltage across two series-connected windings is equal to the voltage across either of the two windings. Then, secondly, by connecting the third winding in series and confirming that the voltage across the three series-connected windings is equal to 0 V.
4. The line voltage $E_{Sec.}$ at the secondary of the three-phase transformer bank connected in a delta-wye configuration can be calculated using the following equation:

$$E_{Sec.} = \frac{E_{Pri.} \times N_{Sec.}}{N_{Pri.}} \times \sqrt{3} = \frac{208 \text{ V} \times 1340 \text{ turns}}{800 \text{ turns}} \times \sqrt{3} = 603 \text{ V}$$

5. The line voltage $E_{Sec.}$ at the secondary of the three-phase transformer bank connected in a wye-delta configuration can be calculated using the following equation:

$$E_{Sec.} = \frac{E_{Pri.} \times N_{Sec.}}{N_{Pri.}} \times \frac{1}{\sqrt{3}} = \frac{75 \text{ kV} \times 1600 \text{ turns}}{4800 \text{ turns}} \times \frac{1}{\sqrt{3}} = 14.4 \text{ kV}$$

Bibliography

Boylestad, Robert L., *Introductory Circuit Analysis*, 11th ed., Upper Saddle River: Prentice Hall, 2006, ISBN 978-0131730441.

Wildi, Theodore, *Electrical Machines, Drives, and Power Systems*, 6th ed., Upper Saddle River: Prentice Hall, 2005, ISBN 978-0131776913.