

<http://waterheatertimer.org/How-to-wire-3-phase-electric.html>

<http://waterheatertimer.org/How-to-identify-transformer-wiring.html>

## COMMON AC POWER DISTRIBUTION CONFIGURATIONS

The input voltage needed to power electronic equipment is provided by the manufacture in the product specifications. Matching this requirement to the facility power available can often raise questions. This paper is intended to assist you in identifying the different power configurations that may be in your facility.

### SINGLE PHASE 120

Single Phase 120 often called house current is the AC power used in commercial buildings and houses to power lights and small appliances. The output voltage is 120Vac line to neutral (L-N). Line to neutral may also be called phase to neutral. There is both a 2 wire and a 3 wire configuration. The 2 wire configuration consists of Phase A and Neutral. This configuration is older and is being replaced by the 3 wire configuration which adds the earth ground connection. The grounded neutral conductor and ground provides a significant safety improvement. See Figure 1. Depending on the actual local power distribution standards, the single phase the voltage may be listed as 110Vac, 115Vac, 117vac or 120 Vac. Even with these stated nominal vales, variation do occur due to grid power demands, transformer losses, and voltage drops due to wiring impedances.

Many low power Ametek power supplies can operate on single phase 120.

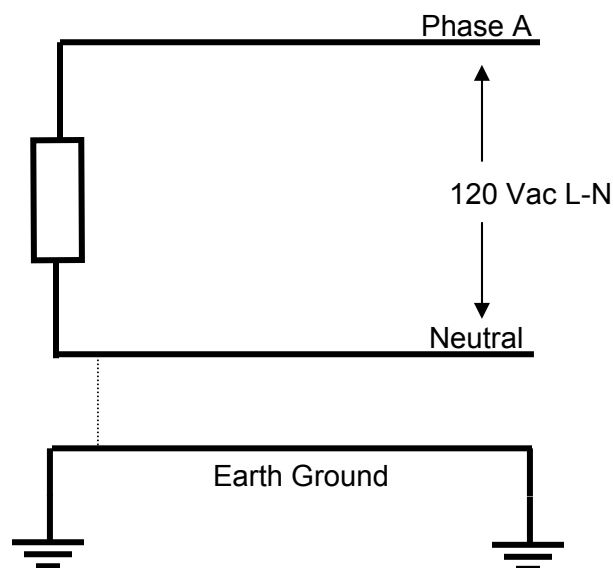

Figure 1 - Single Phase 120

### Single Phase 120/240

Single phase 120/240 is commonly seen as the source for AC power to household cloths driers. It may also be called Split Phase 240. This configuration consists of 2 voltage legs that are 180 degrees apart. The voltage between the two legs (called phase to phase or line to line) is 240V and the phase to neutral voltage is 120V. The 120/240 notation identifies the phase to neutral voltage followed by the phase to phase voltage. Some list the phase to phase voltage first so it may also be called 240/120 single phase. See Figure 2. Medium power Ametek power supplies (< 5 kW) will operate on this voltage configuration.

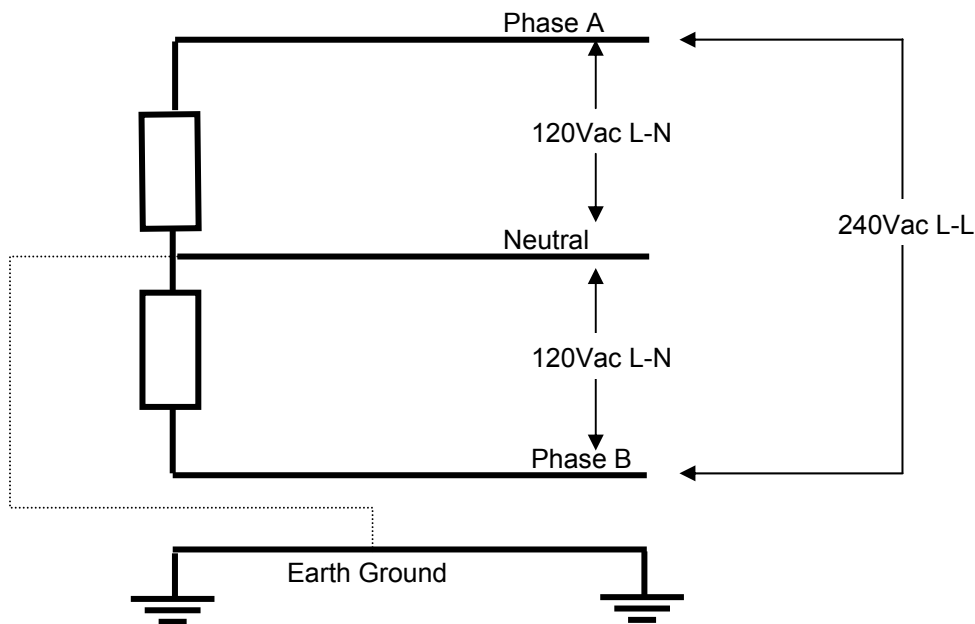

Figure 2 – Single Phase 120/240

### 3 Phase Configurations

AC power is usually distributed in a facility in a 3-phase system consisting of 5 wires. Three of the wires are current carriers and are called phases. These 3 phases are 120 degrees out of phase from each other. The fourth wire is the neutral wire. The neutral wire will not have current flowing in it as long as the current in the three phases are matched.

The 5th wire is Earth Ground. This system is commonly called a 3 phase wye because of the Y shape of the phases.

A 3 phase Wye configuration is shown in Figure 3.

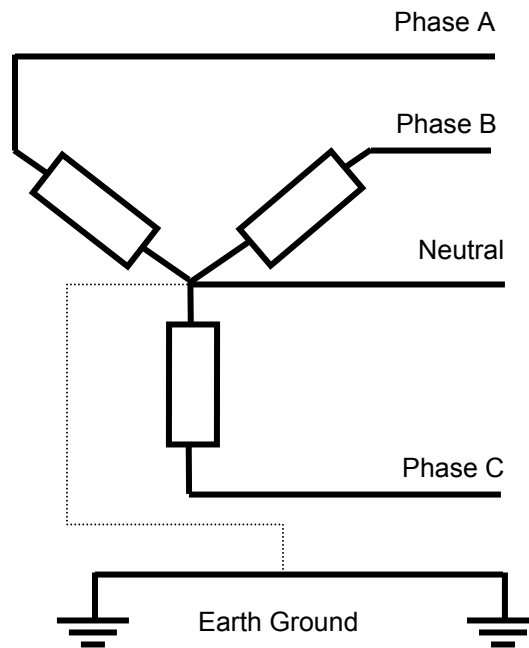

Figure 3 - Typical 3 phase WYE Configuration

In the USA the most common configuration is 208Y/120. This indicates that line to line (L-L) voltage is 208Vac in a WYE configuration and the line to neutral (L-N) voltage is 120Vac. It is also sometimes designated 120/208Vac, 120/208WYE, 208/120 WYE, 4 wire WYE or 120/208Y. See Figure 4. Most Ametek supplies > 5 kW will operate on this configuration.

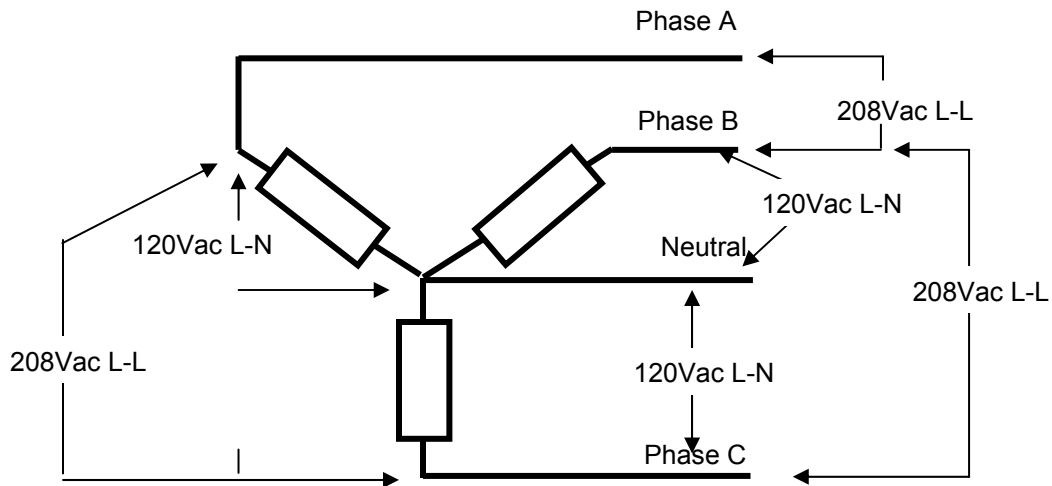

Figure 4 - 208Y/120 Configuration

For higher power capabilities another configuration in the USA is 480Y/277. In this case the line to line voltage is 480Vac in a WYE configuration and the line to neutral voltage is 277Vac. See Figure 5. This configuration is often an optional voltage for most AMETEK supplies 5 kW and larger.

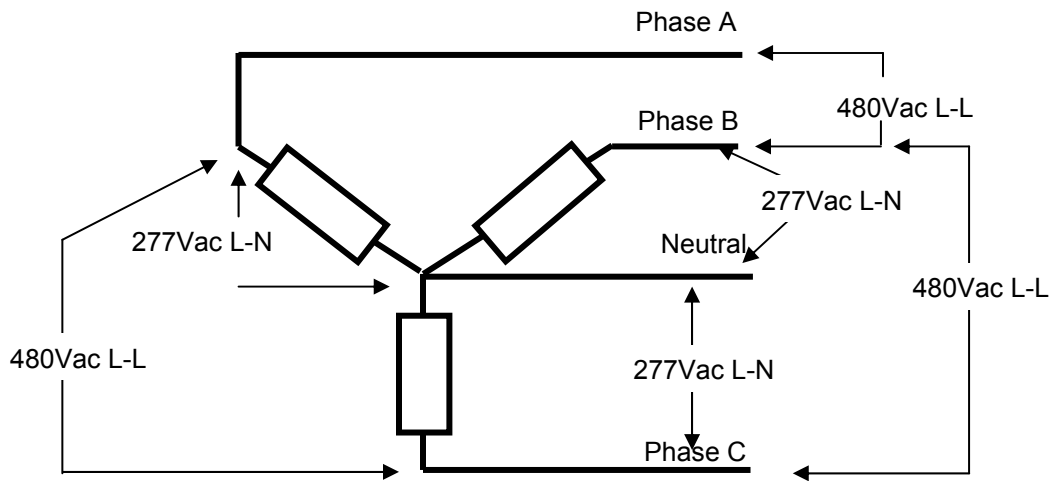

Figure 5 – 480Y/277 Configuration

Since each phase in a 3 phase wye configuration is 120 degrees from each other, the L-L voltage is not the algebraic sum of the L-N voltages but a vector addition. A quick method that can be used if the phase angles are 120 degrees apart is to use the L-N voltage multiplied by  $\sqrt{3}$ .

$$V_{L-N} * \sqrt{3} = V_{L-L} \quad (\text{i.e. } 120\text{Vac} * 1.7333 = \underline{208 \text{ Vac}})$$

$$V_{L-L} \div 1.7333 = V_{L-N} \quad (\text{i.e. } 480\text{Vac} \div 1.7333 = \underline{277 \text{ Vac}})$$

Another variation of the 4 wire WYE configuration is the 5 wire wye configuration that adds an Earth Ground wire which is usually connected to neutral at the circuit breaker panel. See Figure 6.

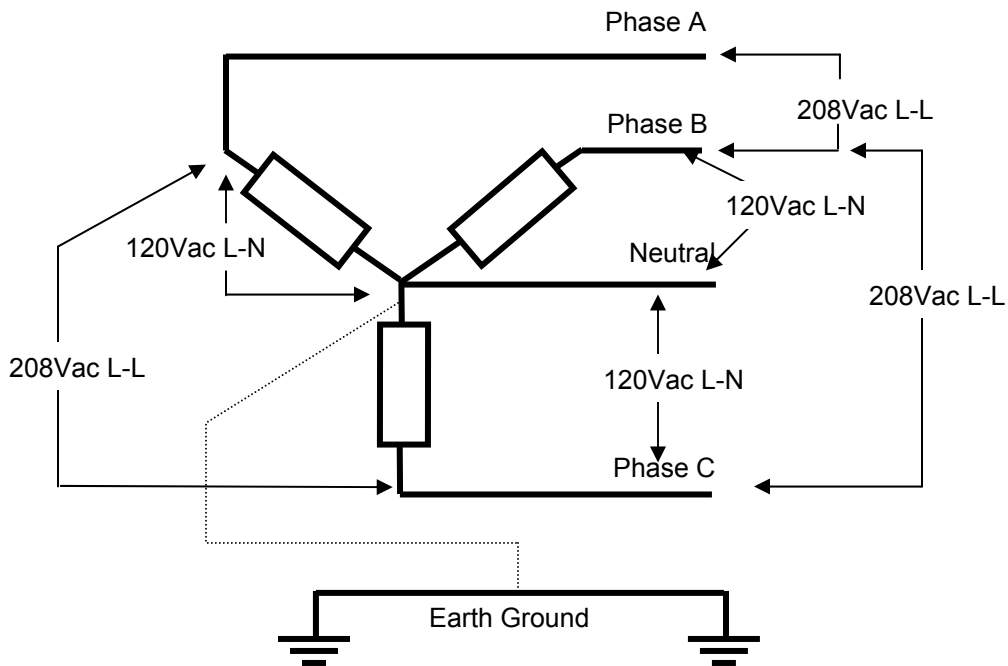

Figure 6 – 208Y/120 5 wire configuration

### 3 Phase Delta Configuration

Although the WYE configuration is the most common configuration there also is the Delta configuration. See Figure 7.

In this configuration, there is no neutral. So the voltage is always a line to line measurement.

$$V_{\text{line}} = V_{\text{phase}} \quad (\text{i.e. } 208\text{Vac} = 208\text{Vac})$$

$$I_{\text{line}} = \sqrt{3} \cdot I_{\text{phase}} \quad (\text{If the phase current is 50 Amps the line current is } 1.733 \cdot 50 \text{ Amps} = 86.6 \text{ Amps})$$

One advantage of a Delta configuration is that it does not have a neutral and therefore if a phase winding should fail the phase voltage at the load will remain constant.

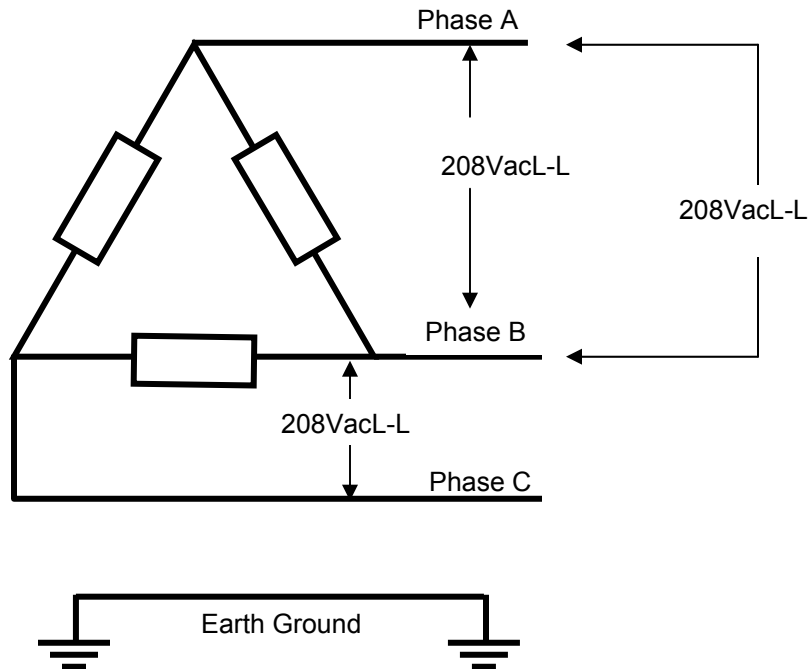

Figure 7 – 3 and 4 wire Delta Configuration

### Open Wye Configuration

There are other distributions that are not common but may be encountered. The first is the 3 phase “open wye”. See Figure 8. This configuration can be used to allow power to be maintained if a phase fails or is in need of maintenance. This would require using a standard 3 phase wye configuration made from 3 single phase transformers. If one of the phases needs to be taken off line for repair the remaining two transformers can be set up in an open wye configuration and continue to operate. When the third phase transformer is available again the three transformers can be reconfigured in a standard wye configuration.

The open phase voltage equals the line voltage/2 and the phase current equals the line current. Power is half that of a 3 phase wye configuration.

$$V_{\text{phase}} = V_{\text{line}} / 2$$

$$I_{\text{phase}} = I_{\text{line}}$$

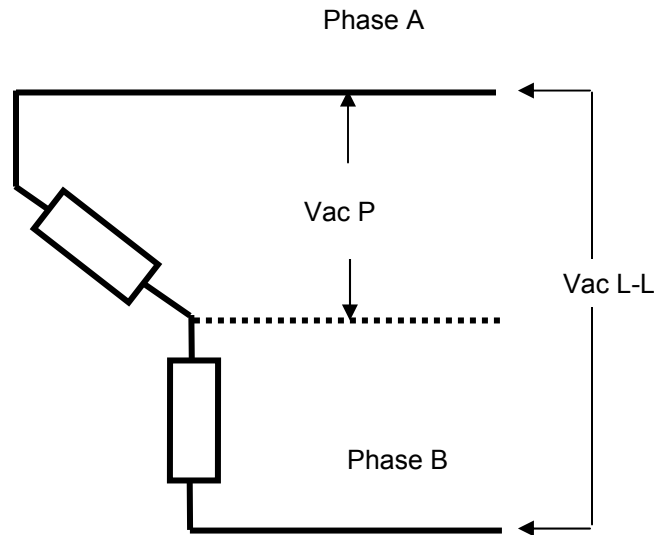

Figure 8 – 3-Phase Open Wye

### 3 Phase Open Delta Configuration

The 3 phase Open Delta configuration would serve the same purpose as the open Wye configuration discussed above and like the open wye would also require using single phase transformers. In this configuration the phase voltage equals the line voltage and the load current equals the phase A and the phase B current. The power available from this configuration is 2/3 of a 3 phase Delta configuration. This configuration is sometimes called V configurations.

$$V_{\text{phase}} = V_{\text{line}}$$

$$I_{\text{phase A}} = I_{\text{phase B}} = I_{\text{load B}}$$

$$I_{\text{L-N}} = 1.73 * I_{\text{Phase A}}$$

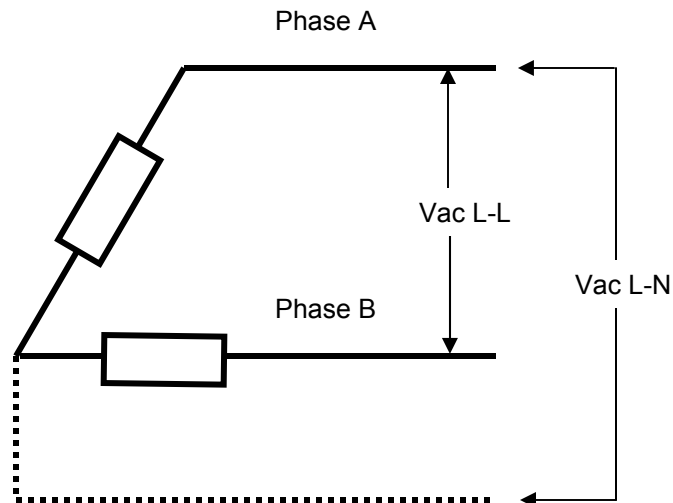

Figure 9 – 3 Phase Open Delta



### 240V Split Phase Delta

The 240V Split Phase Delta or High Leg Delta is a modified 240Volt 4 wire Delta with one phase center taped to provide two phases with 120Vac and a High leg which provides 208Vac in addition to 240 Vac. With this configuration a single system can provide different voltages for a facility that supports offices and factory machinery. This configuration is also known as dog leg or stinger leg. See Figure 10.

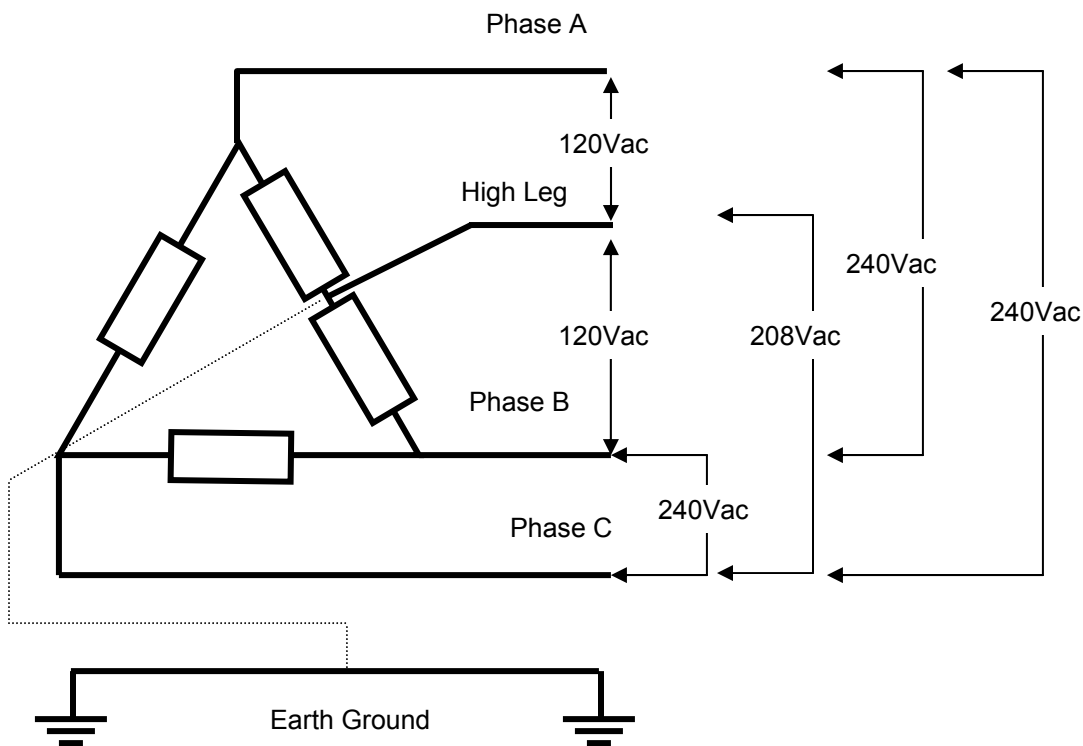

Figure 10 - 240V Split Phase Delta