

SONY

SONY®

HANDYCAM

Digital Video Camera Recorder  
**HANDYCAM®**

**Operating Guide**

***DCR-DVD150E/DVD450E/  
DVD650E/DVD850E***

GB

Enjoying with Your  
Camcorder 11

Getting Started 19

**Recording/Playback 32**

Editing 47

Utilizing Media 65

Customizing Your  
Camcorder 77

Performing with Your  
Computer 93

Troubleshooting 100

Additional  
Information 112

Quick  
Reference 126

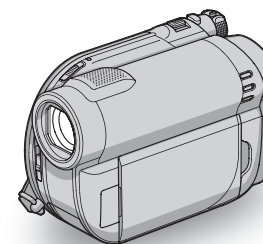

Additional information on this product and answers to frequently asked questions can be found at our Customer Support Website.

<http://www.sony.net/>

 Printed on 70% or more recycled paper using VOC (Volatile Organic Compound)-free vegetable oil based ink.

Printed in China



# Read this before operating your camcorder

Before operating the unit, please read this manual thoroughly, and retain it for future reference.

## WARNING

**To reduce fire or shock hazard, do not expose the unit to rain or moisture.**

Do not expose the batteries to excessive heat such as sunshine, fire or the like.

## CAUTION

### Battery pack

If the battery pack is mishandled, the battery pack can burst, cause a fire or even chemical burns. Observe the following cautions.

- Do not disassemble.
- Do not crush and do not expose the battery pack to any shock or force such as hammering, dropping or stepping on it.
- Do not short circuit and do not allow metal objects to come into contact with the battery terminals.
- Do not expose to high temperature above 60°C (140°F) such as in direct sunlight or in a car parked in the sun.
- Do not incinerate or dispose of in fire.
- Do not handle damaged or leaking lithium ion batteries.
- Be sure to charge the battery pack using a genuine Sony battery charger or a device that can charge the battery pack.
- Keep the battery pack out of the reach of small children.
- Keep the battery pack dry.
- Replace only with the same or equivalent type recommended by Sony.
- Dispose of used battery packs promptly as described in the instructions.

Replace the battery with the specified type only. Otherwise, fire or injury may result.

## AC Adaptor

Do not use the AC Adaptor placed in a narrow space, such as between a wall and furniture.

Use the nearby wall outlet (wall socket) when using the AC Adaptor. Disconnect the AC Adaptor from the wall outlet (wall socket) immediately if any malfunction occurs while using your camcorder.



Even if your camcorder is turned off, AC power source (mains) is still supplied to it while connected to the wall outlet (wall socket) via the AC Adaptor.

## CAUTION

The use of optical instruments with this product will increase eye hazard. Use of controls or adjustments or performance of procedures other than those specified herein may result in hazardous radiation exposure.

## FOR CUSTOMERS IN THE UNITED KINGDOM

A moulded plug complying with BS1363 is fitted to this equipment for your safety and convenience.

Should the fuse in the plug supplied need to be replaced, a fuse of the same rating as the supplied one and approved by ASTA or BSI to BS1362 (i.e., marked with  or ) must be used.

If the plug supplied with this equipment has a detachable fuse cover, be sure to attach the fuse cover after you change the fuse. Never use the plug without the fuse cover. If you should lose the fuse cover, please contact your nearest Sony service station.

## FOR CUSTOMERS IN EUROPE

CLASS 1 LASER PRODUCT  
LASER KLASSE 1  
LUOKAN 1 LASERLAITE  
KLASS 1 LASERAPPARAT

### ATTENTION

The electromagnetic fields at the specific frequencies may influence the picture and sound of this unit.

This product has been tested and found compliant with the limits set out in the EMC Directive for using connection cables shorter than 3 meters (9.8 feet).

### Notice

If static electricity or electromagnetism causes data transfer to discontinue midway (fail), restart the application or disconnect and connect the communication cable (USB, etc.) again.



**Disposal of Old Electrical & Electronic Equipment (Applicable in the European Union and other European countries with separate collection systems)**

This symbol on the product or on its packaging indicates that this product shall not be treated as household waste. Instead it shall be handed over to the applicable collection point for the recycling of electrical and electronic equipment. By ensuring this product is disposed of correctly, you will help prevent potential negative consequences for the environment and human health, which could otherwise be caused by inappropriate waste handling of this product. The recycling of materials will help to conserve natural resources.

For more detailed information about recycling of this product, please contact your local Civic Office, your household waste disposal service or the shop where you purchased the product.



**Disposal of waste batteries (applicable in the European Union and other European countries with separate collection systems)**

This symbol on the battery or on the packaging indicates that the battery provided with this product shall not be treated as household waste. By ensuring these batteries are disposed of correctly, you will help prevent potentially negative consequences for the environment and human health which could otherwise be caused by inappropriate waste handling of the battery. The recycling of the materials will help to conserve natural resources. In case of products that for safety, performance or data integrity reasons require a permanent connection with an incorporated battery, this battery should be replaced by qualified service staff only. To ensure that the battery will be treated properly, hand over the product at end-of-life to the applicable collection point for the recycling of electrical and electronic equipment. For all other batteries, please view the section on how to remove the battery from the product safely. Hand the battery over to the applicable collection point for the recycling of waste batteries.

For more detailed information about recycling of this product or battery, please contact your local Civic Office, your household waste disposal service or the shop where you purchased the product.

### Notice for the customers in the countries applying EU Directives

The manufacturer of this product is Sony Corporation, 1-7-1 Konan Minato-ku Tokyo, 108-0075 Japan. The Authorized Representative for EMC and product safety is Sony Deutschland GmbH, Hedelfinger Strasse 61, 70327 Stuttgart, Germany. For any service or guarantee matters please refer to the addresses given in separate service or guarantee documents.

## Read this before operating your camcorder (Continued)

### For customers in the U.S.A.

If you have any questions about this product, you may call:

Sony Customer Information Center  
1-800-222-SONY (7669).

The number below is for the FCC related matters only.

### Regulatory Information

#### Declaration of Conformity

Trade Name: SONY

Model No.: DCR-DVD650E

Responsible Party: Sony Electronics Inc.

Address: 16530 Via Esprillo, San Diego, CA 92127 U.S.A.

Telephone No.: 858-942-2230

This device complies with Part 15 of the FCC Rules. Operation is subject to the following two conditions: (1) This device may not cause harmful interference, and (2) this device must accept any interference received, including interference that may cause undesired operation.

#### Declaration of Conformity

Trade Name: SONY

Model No.: DCR-DVD850E

Responsible Party: Sony Electronics Inc.

Address: 16530 Via Esprillo, San Diego, CA 92127 U.S.A.

Telephone No.: 858-942-2230

This device complies with Part 15 of the FCC Rules. Operation is subject to the following two conditions: (1) This device may not cause harmful interference, and (2) this device must accept any interference received, including interference that may cause undesired operation.

### CAUTION

You are cautioned that any changes or modifications not expressly approved in this manual could void your authority to operate this equipment.

### Note

This equipment has been tested and found to comply with the limits for a Class B digital device, pursuant to Part 15 of the FCC Rules.

These limits are designed to provide reasonable protection against harmful interference in a residential installation. This equipment generates, uses, and can radiate radio frequency energy and, if not installed and used in accordance with the instructions, may cause harmful interference to radio communications.

However, there is no guarantee that interference will not occur in a particular installation. If this equipment does cause harmful interference to radio or television reception, which can be determined by turning the equipment off and on, the user is encouraged to try to correct the interference by one or more of the following measures:

- Reorient or relocate the receiving antenna.
- Increase the separation between the equipment and receiver.
- Connect the equipment into an outlet on a circuit different from that to which the receiver is connected.
- Consult the dealer or an experienced radio/TV technician for help.

The supplied interface cable must be used with the equipment in order to comply with the limits for a digital device pursuant to Subpart B of Part 15 of FCC Rules.

### Battery pack

This device complies with Part 15 of the FCC Rules. Operation is subject to the following two conditions:

- (1) This device may not cause harmful interference, and (2) this device must accept any interference received, including interference that may cause undesired operation.

### Notes on use

#### Your camcorder is supplied with two kinds of operations guides.

- “Operating Guide” (This manual)
- “PMB Guide” for using your camcorder with a computer connected (stored on the supplied CD-ROM) (p. 97)

#### Types of the disc you can use in your camcorder

You can use the following discs only.

- 8cm DVD-RW
- 8cm DVD+RW
- 8cm DVD-R
- 8cm DVD+R DL

Use the discs with marks listed below. See page 12 for details.



For reliability and durability of recording/playback, we recommend using Sony discs.

### Note

- Using an uncertificated disc may in a few cases cause unsatisfactory recording/playback.

## Types of "Memory Stick" media you can use in your camcorder

- For recording movies, it is recommended that you use "Memory Stick PRO Duo" media of 512 MB or larger marked with:
  - **MEMORY STICK PRO DUO** ("Memory Stick PRO Duo" media)\*
  - **MEMORY STICK PRO-HG DUO** ("Memory Stick PRO-HG Duo" media)
- \* You can use "Memory Stick PRO Duo" media marked either with "Mark2" or without.
- See page 31 for the recordable time of "Memory Stick PRO Duo" media.

"Memory Stick PRO Duo" media/"Memory Stick PRO-HG Duo" media  
(This size can be used with your camcorder.)



"Memory Stick" media  
(You cannot use it in your camcorder.)



- "Memory Stick PRO Duo" media and "Memory Stick PRO-HG Duo" media are both referred to as "Memory Stick PRO Duo" media in this manual.
- You cannot use any type of memory card other than those mentioned above.
- "Memory Stick PRO Duo" media can be used only with "Memory Stick PRO" media compatible equipment.
- Do not attach a label or the like on "Memory Stick PRO Duo" media or a "Memory Stick Duo" media adaptor.
- When using "Memory Stick PRO Duo" media with "Memory Stick" media compatible equipment, be sure to insert the "Memory Stick PRO Duo" media into the "Memory Stick Duo" media adaptor.

## Using the camcorder

- Do not hold the camcorder by the following parts.

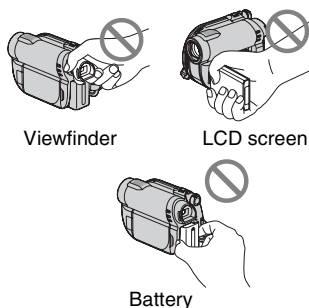

- The camcorder is not dustproofed, dripproofed or waterproofed. See "About handling of your camcorder" (p. 119).
- To prevent media from being broken or recorded images from being lost, do not do the following when either of the (Movie)/ (Still) lamps (p. 23) or the ACCESS/access lamps (p. 28, 30) are on:
  - to remove the battery pack or AC Adaptor from the camcorder
  - to apply mechanical shock or vibration to the camcorder

## Read this before operating your camcorder (Continued)

- When connecting your camcorder to another device with a cable, be sure to insert the connector plug in the correct way. Pushing the plug forcibly into the terminal will damage the terminal and may result in a malfunction of your camcorder.

### About menu items, LCD panel, viewfinder, and lens

- A menu item that is grayed out is not available under the current recording or playback conditions.
- The LCD screen and the viewfinder are manufactured using extremely high-precision technology, so over 99.99% of the pixels are effective. However, there may be some tiny black points and/or bright points (white, red, blue, or green in color) that appear constantly on the LCD screen and the viewfinder. These points are normal results of the manufacturing process and do not affect the recording in any way.

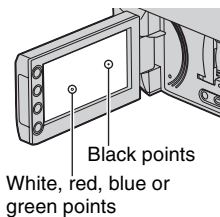

- Exposing the LCD screen, the viewfinder, or the lens to direct sunlight for long periods of time may cause malfunctions.
- Do not aim at the sun. Doing so might cause your camcorder to malfunction. Take images of the sun only in low light conditions, such as at dusk.

### On recording

- Before starting to record, test the recording function to make sure the image and sound are recorded without any problems.

- DCR-DVD150E/DVD650E  
Use a DVD-RW/DVD+RW for trial recording.
- DCR-DVD450E/DVD850E  
Make trial recording on the internal memory.
- Compensation for the contents of recordings cannot be provided, even if recording or playback is not possible due to a malfunction of the camcorder, recording media, etc.
- TV color systems differ depending on the countries/regions. To view your recordings on a TV, you need a PAL system-based TV.
- Television programs, films, video tapes, and other materials may be copyrighted. Unauthorized recording of such materials may be contrary to the copyright laws.
- If you repeat recording/deleting images for a long time, fragmentation of data occurs on the internal memory (DCR-DVD450E/DVD850E) or “Memory Stick PRO Duo” media. Images cannot be saved or recorded. In such a case, save your images on another type of media first (p. 52, 62), and then format the media (p. 71).

### About language setting

The on-screen displays in each local language are used for illustrating the operating procedures. Change the screen language before using your camcorder if necessary (p. 24).

### About disposal/transfer (DCR-DVD450E/DVD850E)

Even if you perform [MEDIA FORMAT] (p. 71) or delete all the images recorded on the internal memory, the data may not be completely deleted from the internal memory. When you give or sell your camcorder to somebody, it is recommended that you perform [ ] EMPTY (p. 76) to prevent the recovery of your data. In addition to the above, when you dispose of

the camcorder, it is recommended that you destroy the actual body of the camcorder.

### About the Carl Zeiss lens

Your camcorder is equipped with a Carl Zeiss lens, which was developed jointly by Carl Zeiss, in Germany, and Sony Corporation, and produces superior images. It adopts the MTF measurement system for video cameras and offers a quality typical of a Carl Zeiss lens.

MTF = Modulation Transfer Function. The number value indicates the amount of light from a subject coming into the lens.

### About this manual

- The LCD screens and the viewfinder images and indicators shown in this manual were taken with a digital still camera, and may look different from what you actually see.
- Discs in this manual refers to 8cm DVD discs.
- In this manual, the internal memory (DCR-DVD450E/DVD850E), a disc and “Memory Stick PRO Duo” media are called the media.
- Unless otherwise specifically indicated, illustrations in this manual are based on DCR-DVD850E.
- Design and specifications of media and other accessories are subject to change without notice.

### About the marks used in this manual

- The operations available depend on the media used. The following marks are used to indicate the type of media you can use for a particular operation.

#### Internal Memory



#### Disc



#### “Memory Stick PRO Duo” media



# Table of Contents

Read this before operating your camcorder .....	2
Table of Contents .....	8
Subject examples and solutions ...	10

## Enjoying with Your Camcorder

Enjoy using various “Media” according to your needs .....	11
Media for your camcorder .....	12
Using your camcorder .....	14
“HOME” and “OPTION” - Taking advantage of two types of menus .....	16

## Getting Started

Step 1: Checking supplied items .....	19
Step 2: Charging the battery pack .....	20
Step 3: Turning the power on, and setting the date and time .....	23
Changing the language setting ...	24
Step 4: Making adjustments before recording .....	25
Step 5: Selecting media .....	26
Step 6: Inserting a disc or “Memory Stick PRO Duo” media .....	28

## Recording/Playback

Recording and playing back with ease (Easy Handycam operation) .....	32
Recording .....	36
Zooming .....	38
Recording sound with more presence (5.1ch surround recording) (DCR-DVD450E/DVD850E) .....	38

Adjusting the exposure for backlit subjects .....	39
Recording in mirror mode .....	39
Playback .....	40
Searching for scenes with pinpoint accuracy (Film Roll Index) .....	42
Searching for desired scenes by a face (Face Index) .....	42
Searching for desired images by date (Date Index) .....	43
Using PB zoom .....	43
Playing back a series of still images (Slide show) .....	44
Playing the images on a TV .....	45

## Editing







(OTHERS) category .....	47
Deleting images .....	48
Capturing a still image from a movie (DCR-DVD450E/DVD650E/DVD850E) .....	50
Dubbing/copying images to media within your camcorder (DCR-DVD450E/DVD650E/DVD850E) .....	52
Protecting images .....	55
Dividing movies .....	58
Creating the Playlist .....	59
Dubbing movies to VCR or DVD/HDD recorders .....	62
Checking battery information .....	64

## Utilizing Media

(MANAGE MEDIA) category .....	65
Making the disc compatible with playback on other devices (Finalizing) .....	66
Playing a disc on other devices ...	69
Checking media information .....	70

Formatting media .....	71
Recording additional movies after finalizing .....	73
Finding the right disc (DISC SELECT GUIDE) .....	74
Repairing the image database file .....	75
Preventing data on the internal memory from being recovered (DCR-DVD450E/DVD850E) .....	76

## Customizing Your Camcorder

What you can do with the  (SETTINGS) category of the  HOME MENU .....	77
Using the HOME MENU .....	77
List of the  (SETTINGS) category items .....	78
MOVIE SETTINGS .....	79
(Items for recording movies)	
PHOTO SETTINGS .....	81
(Items for recording still images)	
VIEW IMAGES SET .....	82
(Items to customize the display)	
SOUND/DISP SET .....	83
(Items to adjust sound and the screen)	
OUTPUT SETTINGS .....	84
(Items for when connecting other devices)	
CLOCK/  LANG .....	84
(Items to set clock and language)	
GENERAL SET .....	85
(Other setup items)	
Activating functions using the  OPTION MENU .....	86
Using the OPTION MENU .....	86
Recording items on the OPTION MENU .....	87
Viewing items on the OPTION MENU .....	87
Functions set in the  OPTION MENU .....	88

## Performing with Your Computer

What you can do with Windows computer .....	93
---	----

## Troubleshooting

Troubleshooting .....	100
Warning indicators and messages .....	108

## Additional Information

Using your camcorder abroad .....	112
File/folder structure on the internal memory (DCR-DVD450E/DVD850E) and "Memory Stick PRO Duo" media .....	114
Maintenance and precautions .....	115
About the disc .....	115
About the "Memory Stick" media .....	116
About the "InfoLITHIUM" battery pack .....	117
About handling of your camcorder .....	119
Specifications .....	123

## Quick Reference

Identifying parts and controls .....	126
Indicators displayed during recording/playback .....	129
Glossary .....	131
Index .....	132

# Subject examples and solutions

## Shooting

### Flowers in close-up



- ▶ PORTRAIT ..... 90
- ▶ FOCUS ..... 89
- ▶ TELE MACRO ..... 89

### Checking your golf swing



- ▶ SPORTS ..... 90

### Focusing on the dog on the left side of the screen



- ▶ SPOT MTR/FCS ..... 88
- ▶ FOCUS ..... 89
- ▶ SPOT FOCUS ..... 88

### A child on the stage under a spot light



- ▶ SPOTLIGHT ..... 90

### Getting a good shot of a ski slope or beach



- ▶ Backlight ..... 39
- ▶ BEACH ..... 90
- ▶ SNOW ..... 90

### Fireworks with all its splendor



- ▶ FIREWORKS ..... 90
- ▶ FOCUS ..... 89

# Enjoy using various “Media” according to your needs

## Selecting media

You can select desired media for recording/playback/editing from the internal memory (DCR-DVD450E/DVD850E), a disc or “Memory Stick PRO Duo” media (p. 26). To set the media for movies or still images, you can select either [MOVIE MEDIA SET] or [PHOTO MEDIA SET] (DCR-DVD450E/DVD850E) according to your needs.

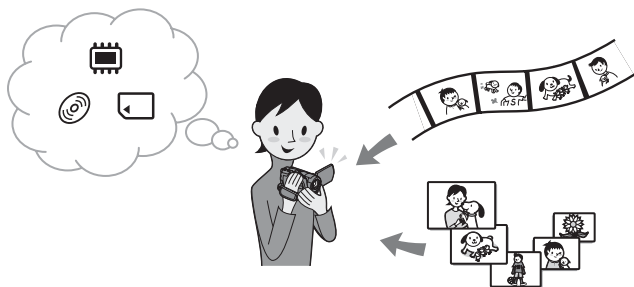

## Dubbing from one type of media to another

Using the [MOVIE DUB] function on the camcorder, you can dub movies recorded on the internal memory (DCR-DVD450E/DVD850E) or “Memory Stick PRO Duo” media to a disc without connecting another device (p. 52).

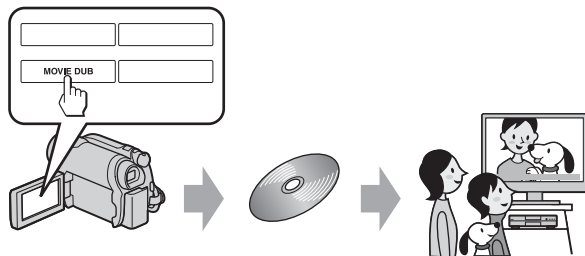

### Notes



- You may not be able to dub movie contents depending on the type of your camcorder. For details on the compatibility of types, see page 52.



# Media for your camcorder

With your camcorder, you can record images on either the internal memory (DCR-DVD450E/DVD850E), an 8cm DVD-RW, DVD+RW, DVD-R or DVD+R DL disc, or “Memory Stick PRO Duo” media. See page 5 for the types of “Memory Stick” media you can use in your camcorder.

## Recording format for DVD-RW

When you use a DVD-RW, you can choose the recording format from VIDEO mode or VR mode.









In this manual, VIDEO mode is indicated as  and VR mode as .

	A recording format that is compatible with most DVD devices, especially after finalizing. <b>In VIDEO mode, only the most recent movie can be deleted.</b>
	A recording format that enables editing with your camcorder (deleting and rearranging the order of images). A finalized disc can be played back in DVD devices that support VR mode. Refer to the instruction manual of your DVD device to see whether it supports the VR mode of DVD-RW.

VIDEO mode and VR mode  Glossary (p. 131)

## Disc features

Figures in parentheses ( ) indicate reference pages.

Disc types and symbols	DVD-RW	DVD+RW	DVD-R	DVD+R DL	
					
Symbols used in this manual					
Both 16:9 (wide) and 4:3 movie can be recorded on the same disc (28)	●	●	—	●	●
Deleting the most recent movie (49)	●	●	●	—	—
Deleting or editing movie on your camcorder (48)	—	●	—	—	—
Using a disc repeatedly by formatting, even if the disc becomes full* (71)	●	●	●	—	—
Finalizing required to play on other devices (66)	●	●	—**	●	●
Making longer recordings on a side of a disc	—	—	—	—	●

\* Formatting deletes all images and returns the recording media to its original empty state (p. 71). Even when using a new disc, format it with your camcorder (p. 28).





\*\* Finalizing is required to play the disc in a DVD drive on a computer. A DVD+RW that is not finalized may cause the computer to malfunction.

## Recording time of movies

Figures in the table are the approximate recording time in minutes using the internal memory (DCR-DVD450E/DVD850E) and on one side of a disc.

The recordable time on the acceptable media varies depending on media type and the [REC MODE] (p. 79) setting.

Figures in ( ) are the minimum recording time.

Media type			  	
9M (HQ) (high quality)		230 (205)	20 (18)	35 (32)
6M (SP) (standard quality)		340 (205)	30 (18)	55 (32)
3M (LP) (long play)	5.1ch*	655 (435)	60 (44)	110 (80)
	2ch	715 (460)	65 (46)	125 (90)

\* DCR-DVD450E/DVD850E

### Tips

- Figures such as 9M and 6M in the table show the average bit rate. M stands for Mbps.
- For DCR-DVD450E/DVD850E: You can select the audio recording format of movies with [AUDIO MODE] (p. 79).  
For DCR-DVD150E/DVD650E: Sound is recorded in 2ch stereo.
- You can check the recordable time with [MEDIA INFO] (p. 70).
- When you use a double-sided disc, you can record images on both sides (p. 115).
- See page 31 for the recordable time on “Memory Stick PRO Duo” media.

Your camcorder uses the VBR (Variable Bit Rate) format to automatically adjust image quality to suit the recording scene. This technology causes fluctuations in the recording time of media. Movies containing quickly moving and complex images are recorded at a higher bit rate, and this reduces the overall recording time.

# Using your camcorder

## ① Selecting media (p. 26)

You can select media separately for movies and still images.

In the case of recording on a disc, select the disc that best suits your needs.

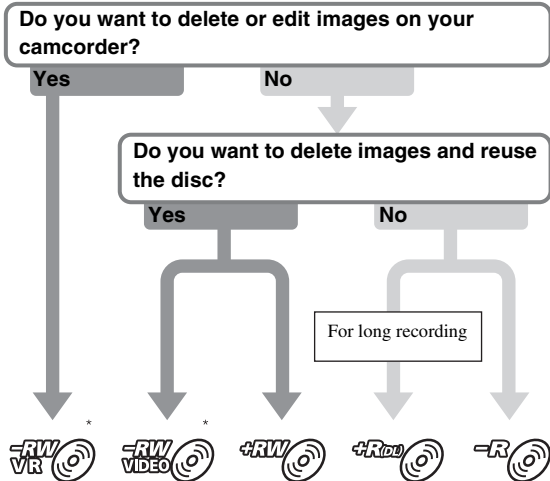

\* Select the recording format and format the disc on your camcorder (p. 28).

### 💡 Tips

- You can select the disc from [DISC SELECT GUIDE] (p. 74).

## ② Recording images (p. 36)

## ③ Editing/Saving images

The available functions depend on the selected media.

- Dubbing/copying images to another type of media within your camcorder (p. 52)
- Dubbing movies to other devices (p. 62)
- Editing on a computer (p. 93)

Using the supplied application software “PMB” (Picture Motion Browser), you can import images to a computer, and save them on a disc.

## ④ Viewing on other devices

### ■ Viewing images on a TV (p. 45)

You can view the images recorded and edited on your camcorder on the connected TV.

### ■ Playing the disc on other devices (p. 69)

To play a disc recorded on your camcorder on other devices, you need to finalize the disc first.

#### 📌 Notes

- The less the recording volume of the disc is, the more it takes time to finalize the disc.

### The features of a finalized disc depend on disc type.

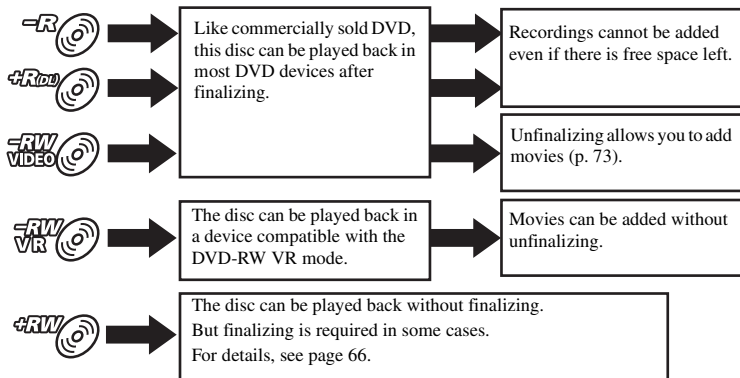

### Playback compatibility

Playback compatibility with all DVD devices is not guaranteed. Refer to the instruction manual supplied with your DVD device or consult your dealer.

# “HOME” and “OPTION”

## - Taking advantage of two types of menus

“HOME MENU” - the starting point for operations with your camcorder

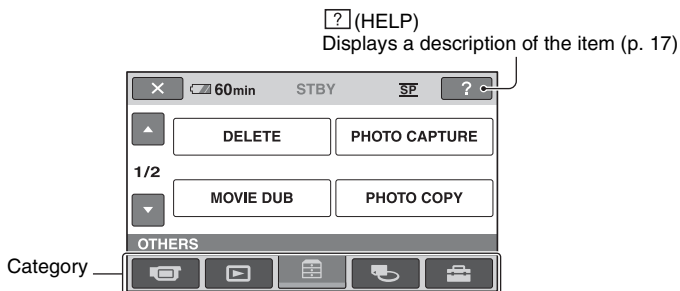

### ► Categories and items of the HOME MENU

#### (CAMERA) category

Items	Page
MOVIE* <sup>1</sup>	37
PHOTO* <sup>1</sup>	37

#### (VIEW IMAGES) category

Items	Page
VISUAL INDEX* <sup>1</sup>	40
FILM ROLL* <sup>1</sup>	42
FACE* <sup>1</sup>	42
PLAYLIST	59

#### (OTHERS) category

Items	Page
DELETE* <sup>2</sup>	48
PHOTO CAPTURE* <sup>3</sup>	50
MOVIE DUB* <sup>3</sup>	52
PHOTO COPY* <sup>3</sup>	53
EDIT	55
PLAYLIST EDIT	59
USB CONNECT	93
BATTERY INFO	64

#### (MANAGE MEDIA) category

Items	Page
MOVIE MEDIA SET* <sup>1</sup>	26
PHOTO MEDIA SET* <sup>1*3</sup>	26
FINALIZE* <sup>1</sup>	66
MEDIA INFO	70
MEDIA FORMAT* <sup>1</sup>	71
UNFINALIZE	73
DISC SELECT GUIDE	74
REPAIR IMG.DB F.	75

#### (SETTINGS) category\*<sup>1</sup>

To customize your camcorder (p. 77).

- \*<sup>1</sup> You can also set these items during Easy Handycam operation (p. 32). For items available in the (SETTINGS) category, see page 78.
- \*<sup>2</sup> The item is available during Easy Handycam operation (p. 32) when you select [INT. MEMORY] (DCR-DVD450E/DVD850E) or [MEMORY STICK] on [MOVIE MEDIA SET] (p. 26).
- \*<sup>3</sup> You may not be able to use this item depending on your camcorder model.

## Using the HOME MENU

- 1 While pressing the green button, turn the POWER switch in the direction of the arrow to turn on your camcorder.

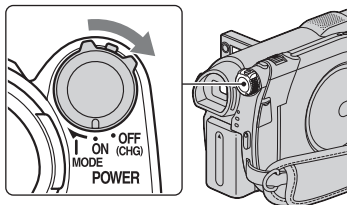

- 2 Press **↑** (HOME) **[A]** (or **[B]**).

**↑** (HOME) **[A]**

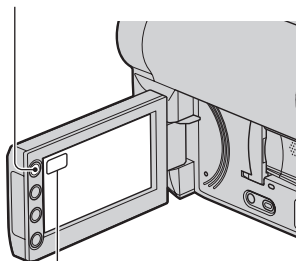

**↑** (HOME) **[B]**

- 3 Touch the desired category.

Example: **[OTHERS]** category

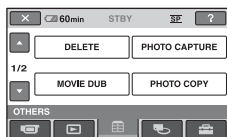

- 4 Touch the desired item.

Example: [EDIT]

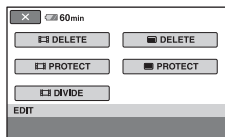

- 5 Follow the guide on the screen for further operation.

### To hide the HOME MENU screen

Touch **[X]**.

When you want to know something about the function of each item on the HOME MENU - HELP

- 1 Press **↑** (HOME).

The HOME MENU appears.



- 2 Touch **[?]** (HELP).

The bottom of **[?]** (HELP) turns orange.



**3** Touch the item you want to know the content.



When you touch an item, its explanation appears on the screen.

To apply the option, touch [YES], otherwise, touch [NO].

**To deactivate the HELP**

Touch [?] (HELP) again in step 2.

**Using the OPTION MENU**

Just a touch on the screen during shooting or playback displays the functions available at that moment. You will find it easy to make various settings. See page 86 for further details.

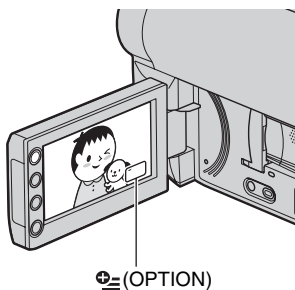

## Step 1: Checking supplied items

Make sure that you have the following items supplied with your camcorder. The number in the parentheses indicates the number of that item supplied.

AC Adaptor (1) (p. 20)

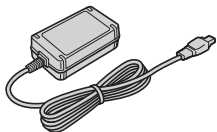

Power cord (mains lead) (1) (p. 20)



A/V connecting cable (1) (p. 45, 62)



USB cable (1) (p. 63)

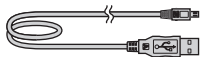

Rechargeable battery pack NP-FH30 (1) (p. 20)

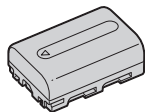

CD-ROM "Handycam Application Software" (1) (p. 93)

– PMB (software) including "PMB Guide"

Operating Guide (This manual) (1)

## Step 2: Charging the battery pack

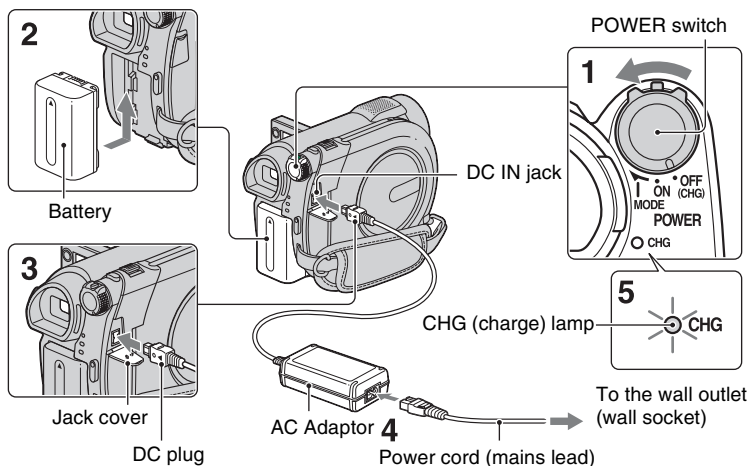

You can charge the “InfoLITHIUM” battery pack (H series) (p. 117) after attaching it to your camcorder.

### ⚡ Notes

- Your camcorder operates only with “InfoLITHIUM” battery pack (H series).

**1** Turn the POWER switch in the direction of the arrow to OFF (CHG) (the default setting).

**2** Attach the battery pack by sliding it in the direction of the arrow until it clicks.

**3** Connect the AC Adaptor to the DC IN jack of your camcorder.

Open the jack cover, and connect the DC plug of the AC Adaptor.

Match the ▲ mark on the DC plug with the ▲ mark on your camcorder.

**4** Connect the power cord (mains lead) to the AC Adaptor and the wall outlet (wall socket).

The CHG (charge) lamp lights up and charging starts.

**5** The CHG (charge) lamp turns off when the battery is fully charged. Disconnect the AC Adaptor from the DC IN jack.

### ⚡ Notes

- Disconnect the AC Adaptor from the DC IN jack holding both the camcorder and the DC plug.

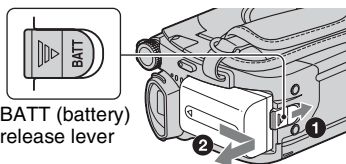

## To remove the battery pack

- Turn the POWER switch to OFF (CHG).
- Slide the BATT (battery) release lever (1) and remove the battery pack (2).



BATT (battery) release lever

### Notes

- When you remove the battery pack or the AC Adaptor, make sure that the  (Movie) lamp/  (Still) lamp (p. 23)/ACCESS lamp (p. 28)/ access lamp (p. 30) are turned off.
- When you store the battery pack, fully discharge the battery before storing it for an extended period (p. 117).

## To use a power source from a wall outlet (wall socket)

Make the same connections as you do when charging the battery pack. The battery pack will not lose its charge in this case.

## Charging time

Approximate time (min.) required when you fully charge a fully discharged battery pack.

Battery pack	Charging time
NP-FH30 (supplied)	115
NP-FH50	135
NP-FH70	170
NP-FH100	390

## Recording time

Approximate time (min.) available when you use a fully charged battery pack.

### When recording on the internal memory (DCR-DVD450E/DVD850E) or "Memory Stick PRO Duo" media

Battery pack	Continuous recording time	Typical recording time*
NP-FH30 (supplied)	95	45
	105	50
NP-FH50	155	75
	170	85
NP-FH70	330	165
	370	185
NP-FH100	745	370
	830	415

### When recording on a disc

Battery pack	Continuous recording time	Typical recording time*
NP-FH30 (supplied)	80	40
	90	45
NP-FH50	135	65
	145	70
NP-FH70	290	145
	315	155
NP-FH100	650	325
	710	355

\* Typical recording time shows the time when you repeat recording start/stop, turning the power on/off and zooming.

### Notes

- See page 26 for selecting the media.
- All times measured with recording mode [SP] under the following conditions:  
Top: When recording with the LCD panel.  
Bottom: When recording with the viewfinder while the LCD panel is closed.

## Step 2: Charging the battery pack (Continued)

### Playing time

Approximate time (min.) available when you use a fully charged battery pack.

### When playing the internal memory (DCR-DVD450E/DVD850E) or “Memory Stick PRO Duo” media

Battery pack	LCD panel opened	LCD panel closed
NP-FH30 (supplied)	125	145
NP-FH50	205	235
NP-FH70	435	505
NP-FH100	980	1120



### When playing a disc

Battery pack	LCD panel opened	LCD panel closed
NP-FH30 (supplied)	105	120
NP-FH50	170	195
NP-FH70	370	415
NP-FH100	830	925

### Notes

- See page 26 for selecting the media.

### On the battery pack

- Before changing the battery pack, turn the POWER switch to OFF (CHG) and turn off the  (Movie) lamp/  (Still) lamp (p. 23)/ ACCESS lamp (p. 28)/access lamp (p. 30).
- The CHG (charge) lamp flashes during charging, or Battery Info (p. 64) will not be correctly displayed under the following conditions:
  - The battery pack is not attached correctly.
  - The battery pack is damaged.
  - The battery pack is worn-out (for Battery Info only).

### On the charging/recording/playback time

- Times measured with the camcorder at 25 °C (77 °F). 10 °C to 30 °C (50 °F to 86 °F) is recommended.
- The available recording and playback time will be shorter when you use your camcorder in low temperatures.
- The available recording and playback time will be shorter depending on the conditions under which you use your camcorder.

### On the AC Adaptor

- Do not short-circuit the DC plug of the AC Adaptor or battery terminal with any metallic objects. This may cause a malfunction.

# Step 3: Turning the power on, and setting the date and time

Set the date and time when using this camcorder for the first time. If you do not set the date and time, the [CLOCK SET] screen appears every time you turn on your camcorder or change the POWER switch position.

Touch the button on the LCD screen.

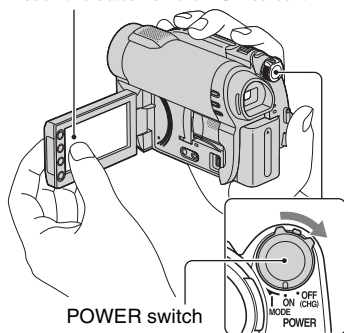

POWER switch

- 1 While pressing the green button, turn the POWER switch repeatedly in the direction of the arrow until the respective lamp lights up.

(Movie): To record movies

(Still): To record still images

Go to step 3 when you turn on your camcorder for the first time.

- 2 Touch (HOME) → (SETTINGS) → [CLOCK/ LANG] → [CLOCK SET].

The [CLOCK SET] screen appears.

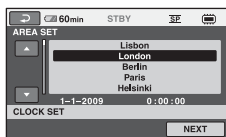

- 3 Select the desired geographical area with /, then touch [NEXT].

- 4 Set [SUMMERTIME], then touch [NEXT].

- 5 Set [Y] (year) with /.



- 6 Select [M] with /, then set the month with /.

- 7 Set [D] (day), hour and minute in the same way, then touch [NEXT].

- 8 Make sure that the clock is correctly set, then touch .

The clock starts.

You can set any year up to the year 2037.

## To turn off the power

Turn the POWER switch to OFF (CHG). The (Movie) lamp flashes for a few seconds, and the power turns off.

## Step 3: Turning the power on, and setting the date and time (Continued)

### Notes





- If you do not use your camcorder for **about 3 months**, the built-in rechargeable battery gets discharged and the date and time settings may be cleared from the memory. In that case, charge the built-in rechargeable battery and then set the date and time again (p. 122).
- It takes a few seconds for your camcorder to be ready to shoot after the power is turned on. You cannot operate your camcorder during this time.
- In the default setting, the power turns off automatically if you leave your camcorder unoperated for approximately 5 minutes, to save battery power ([A.SHUT OFF], p. 85).

### Tips

- The date and time does not appear during recording, but they are automatically recorded on the media, and can be displayed during playback ([DATA CODE], p. 82).
- See page 113 for information concerning “World time difference.”
- If the buttons on the touch panel do not work correctly, adjust the touch panel ([CALIBRATION], p. 120).

## Changing the language setting

You can change the on-screen displays to show messages in a specified language.

Touch  (HOME) →  (SETTINGS)  
→ [CLOCK/ LANG] →  
[ LANGUAGE SET], then select the  
desired language.

# Step 4: Making adjustments before recording

## Opening the lens cover

Slide the LENS COVER switch to OPEN.

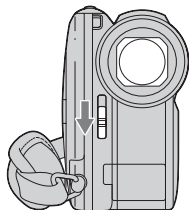

After recording, set the LENS COVER switch to CLOSE to close the lens cover.

## Adjusting the LCD panel

Open the LCD panel 90 degrees to the camcorder (①), then rotate it to the best angle to record or play (②).

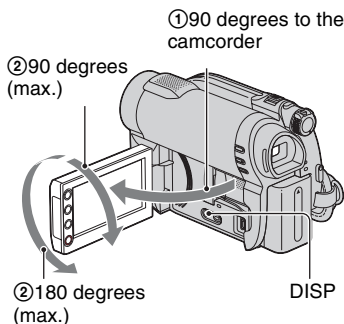

### Notes

- Do not press the buttons on the LCD frame accidentally when you open or adjust the LCD panel.

### Tips

- If you open the LCD panel 90 degrees to the camcorder, then rotate it 180 degrees to the lens side, you can close the LCD panel with the LCD screen facing out. This is convenient during playback operations.

- Touch (HOME) → (SETTINGS) → [SOUND/DISP SET] → [LCD BRIGHT] (p. 83), and adjust the brightness of the LCD screen.
- The information is displayed or hidden (display ↔ no display) each time you press DISP.

## Adjusting the viewfinder

You can view images using the viewfinder to avoid wearing down the battery, or when the image seen on the LCD screen is poor. Pull out and look into the viewfinder. Adjust the viewfinder to your eyesight.

Viewfinder

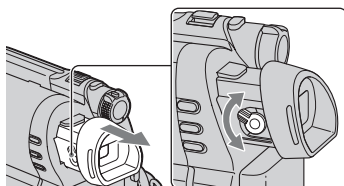

Viewfinder lens adjustment lever  
Move it until the image becomes clear.

## Fastening the grip belt

Adjust and fasten the grip belt as illustrated, and hold your camcorder properly.

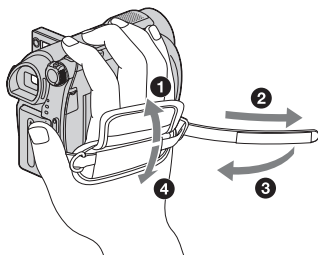

# Step 5: Selecting media

You can set the media to be used for movies and still images separately.

For movies, you can select the internal memory\*, a disc, or “Memory Stick PRO Duo” media.

For still images, you can select the internal memory\*, or “Memory Stick PRO Duo” media.

## DCR-DVD150E/DVD650E

In the default setting, movies are recorded on a disc. Still images are recorded on “Memory Stick PRO Duo” media only.

## DCR-DVD450E/DVD850E

In the default setting, both movies and still images are recorded on the internal memory.

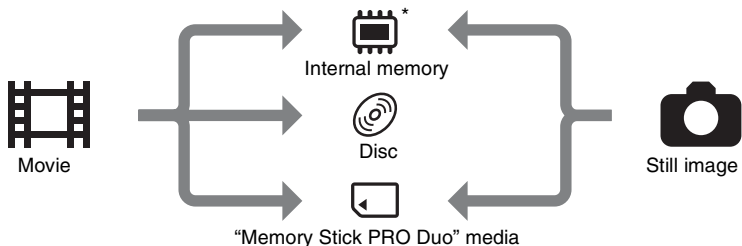

\* DCR-DVD450E/DVD850E

### Notes

- You can record, play back, or edit images on the selected media. When you record, play back, or edit images on other media, select media again.

## Selecting media for movies

- 1 Touch **HOME** → **MANAGE MEDIA** → **[MOVIE MEDIA SET]**.

The movie media setting screen appears.

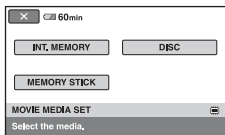

- 4 When **[Completed.]** appears, touch **[OK]**.

The movie media is changed.

- 2 Touch the desired media.

- 3 Touch **[YES]**.

## Selecting media for still images (DCR-DVD450E/DVD850E)

- 1 Touch **HOME** → **MANAGE MEDIA** → **[PHOTO MEDIA SET]**.

The still image media setting screen appears.

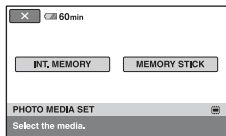

- 2 Touch the desired media.

### Notes

- You cannot select a disc for the still image media.

- 3 Touch **[YES]**.

- 4 When **[Completed.]** appears, touch **[OK]**.

The still image media is changed.

## To confirm the selected media

- 1 Slide the **POWER** switch to turn on the lamp of the mode (**Movie**/**Still**) that you want to check the media.
- 2 Confirm the media icon displayed at the upper right corner of the screen.

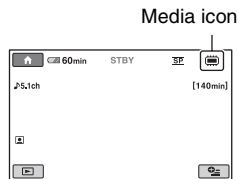

Internal memory\*



Disc (The icon differs depending on the disc type (p. 12).)



“Memory Stick PRO Duo” media

\* DCR-DVD450E/DVD850E

# Step 6: Inserting a disc or “Memory Stick PRO Duo” media

When you select [INT. MEMORY] in “Step 5,” this “Step 6” operation is unnecessary (DCR-DVD450E/DVD850E).

## Inserting a disc

When you select [DISC] in “Step 5,” a new 8 cm DVD-RW, DVD+RW, DVD-R, or DVD+R DL is required (p. 12).

### Notes

- Remove dust or fingerprints from the disc beforehand, using a soft cloth (p. 116).

**1** Check that the power of your camcorder is on.

**2** Slide the disc cover **OPEN** switch in the direction of the arrow (**OPEN** →).

[PREPARING TO OPEN] appears on the screen. The disc cover slightly opens automatically.

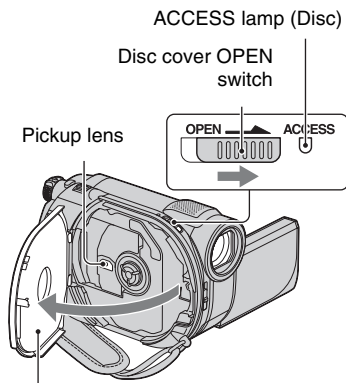

When the disc cover opens slightly, open it further.

**3** Set the disc with the recording side facing your camcorder, then press the center of the disc until it clicks.

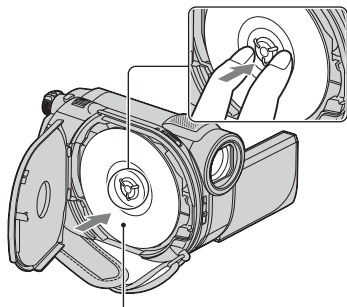

Set the disc with the label side facing out when using a single-sided disc.

**4** Close the disc cover.

[DISC ACCESS] appears on the screen.

It may take some time for the camcorder to recognize the disc.

### ■ DVD-RW/DVD+RW

A screen appears to ask whether you will use [DISC SELECT GUIDE]. Using [DISC SELECT GUIDE] lets you format the disc by following the guidance on the screen. If you do not want to use it, proceed to step 5.

### ■ DVD-R/DVD+R DL

You can start recording immediately after [DISC ACCESS] disappears from the screen. You do not need to proceed to steps after step 5.

## 5 Touch the option that is right for you on the screen.

### ■ DVD-RW

Select the recording format, [VIDEO] or [VR] (p. 12), then touch **[OK]**.

### ■ DVD+RW

Select the aspect ratio of the movie, [16:9 WIDE] or [4:3], then touch **[OK]**.

## 6 Touch [YES].

## 7 When [Completed.] is displayed, touch **[OK]**.

When the formatting is completed, you can start recording on the disc.

### 💡 Tips

- When you use a DVD-RW while the Easy Handycam operation (p. 32) is set, the recording format is fixed to VIDEO mode.

### To remove the disc

- ① Perform steps **1** and **2** to open the disc cover.
- ② Press the disc holder in the center of the disc compartment, and remove the disc by holding the edge.

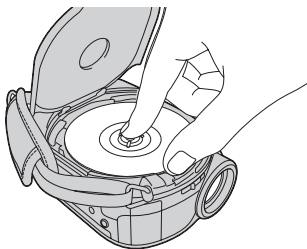

### 📌 Notes

- Be careful not to obstruct the operation with your hand or other objects, when opening or closing the disc cover. Move the grip belt to the bottom of the camcorder, then open or close the disc cover.
- If you catch the grip belt when closing the disc cover, it may cause your camcorder to malfunction.
- Do not touch the disc with the recording side or pickup lens (p. 121). When using a double-sided disc, take care not to smudge the surface with fingerprints.
- If you close the disc cover with the disc set incorrectly, it may cause your camcorder to malfunction.
- Do not disconnect the power sources while formatting a disc.
- Do not apply shock or vibration to your camcorder since your camcorder is reading/writing on the disc:
  - while the ACCESS lamp is on
  - while the ACCESS lamp is flashing
  - while [DISC ACCESS] or [PREPARING TO OPEN] is displayed on the LCD screen
- It may take some time to remove the disc depending on the recorded contents.
- It may take about 10 minutes to remove a disc if the disc has scratches or is dirty with fingerprints, etc. In that case, the disc might be damaged.

### 💡 Tips

- You can insert or remove the disc when a power source is connected to your camcorder even when your camcorder is turned off. However, the disc recognition process (step **4**) does not start.
- To delete all of the previously recorded images from a DVD-RW/DVD+RW, then to use it again to record new images, see “Formatting media” (p. 71).
- You can check the right disc using [DISC SELECT GUIDE] on the HOME MENU (p. 74).

## Step 6: Inserting a disc or “Memory Stick PRO Duo” media (Continued)

### Inserting “Memory Stick PRO Duo” media

This operation is necessary only when you select [MEMORY STICK] in “Step 5.” See page 5 on the “Memory Stick” media you can use with your camcorder.

#### Tips

- If you record only still images on the “Memory Stick PRO Duo” media, operations after step 3 are unnecessary.

### 1 Open the LCD panel.

### 2 Insert the “Memory Stick PRO Duo” media.

- 1 Open the “Memory Stick Duo” media cover in the direction of the arrow.
- 2 Insert the “Memory Stick PRO Duo” media into the “Memory Stick Duo” media slot in the right direction until it clicks.
- 3 Close the “Memory Stick Duo” media cover.

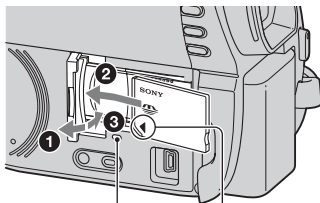

Access lamp

Face the ◀ mark towards the LCD screen.

### 3 If you select [MEMORY STICK] in “Step 5” for movie recording, slide the POWER switch repeatedly until the (Movie) lamp lights up.

If the POWER switch is set to OFF (CHG), turn it on while pressing the green button.

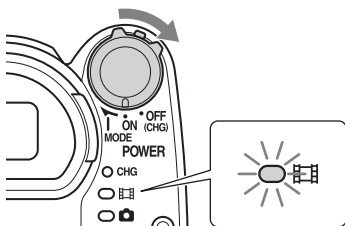

The [Create a new Image Database File.] screen appears on the screen if you insert new “Memory Stick PRO Duo” media when the camcorder is on.

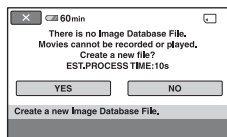

### 4 Touch [YES].



## To remove the “Memory Stick PRO Duo” media

Open the LCD panel and “Memory Stick Duo” media cover. Lightly push the “Memory Stick PRO Duo” media in once, then slide it out of the slot.

### Notes

- To prevent media from being broken or recorded images from being lost, do not do the following when the access lamp ( p. 30) is on:
  - to remove the battery pack or AC Adaptor from the camcorder
  - to apply mechanical shock or vibration to the camcorder
- to remove the “Memory Stick PRO Duo” media from the camcorder
- Do not open the “Memory Stick Duo” media cover during recording.
- Inserting “Memory Stick PRO Duo” media forcibly in the wrong direction may cause a malfunction to the “Memory Stick PRO Duo” media, “Memory Stick Duo” media slot, or image data.
- If [Failed to create a new Image Database File. It may be possible that there is not enough free space.] is displayed in step 4, format the “Memory Stick PRO Duo” media (p. 71). All recorded data on the “Memory Stick PRO Duo” media will be deleted when you format.
- Do not pinch and remove the “Memory Stick PRO Duo” media forcibly. It may cause a malfunction.

## Recording time of movies on “Memory Stick PRO Duo” media

Figures in the table are approximate recording time in minutes of “Memory Stick PRO Duo” media.

Figures in ( ) are minimum recording time.

Recording mode	9M (HQ) (high quality)	6M (SP) (standard quality)	3M (LP) (long play)	
			5.1ch*	2ch
512MB	6 (5)	9 (5)	15 (10)	20 (10)
1GB	10 (10)	20 (10)	35 (25)	40 (25)
2GB	25 (25)	40 (25)	80 (50)	85 (55)
4GB	55 (50)	80 (50)	160 (105)	170 (110)
8GB	115 (100)	170 (100)	325 (215)	355 (230)
16GB	230 (205)	340 (205)	655 (435)	715 (460)

\* DCR-DVD450E/DVD850E

### Notes

- Numbers in the table are of when using “Memory Stick PRO Duo” media made by Sony Corporation. The recordable time varies depending on the recording conditions, the type of “Memory Stick” media, or the [REC MODE] setting (p. 79).
- When the recordable time is less than 5 minutes,  appears.

### Tips

- For DCR-DVD450E/DVD850E: You can select the audio recording format of movies with [AUDIO MODE] (p. 79).  
For DCR-DVD150E/DVD650E: Sound is recorded in 2ch stereo.
- See page 81 for the recordable numbers of still images.

# Recording and playing back with ease (Easy Handycam operation)

Easy Handycam operation makes nearly all settings automatic so that you can perform recording or playing back operation without detailed settings. It also makes the screen font size larger for easy viewing. The images are recorded on the selected media (p. 26).

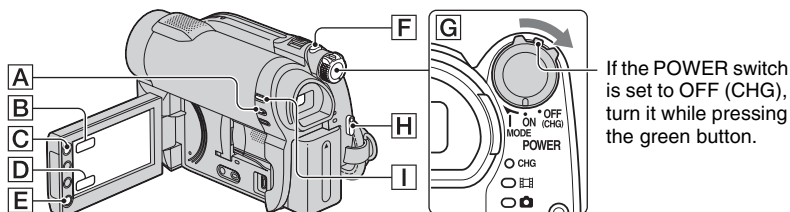

## Movies



- 1** Turn the POWER switch **G** until the (Movie) lamp lights up.



- 2** Press EASY **A**.



- 3** Press START/STOP **H** (or **E**) to start recording.\*

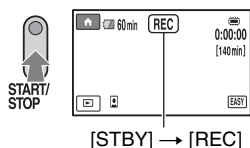

To stop recording, press START/STOP again.

## Still Images



- 1** Turn the POWER switch **G** until the (Still) lamp lights up.



- 2** Press EASY **A**.



- 3** Press PHOTO **F** lightly to adjust the focus **A** (a beep sounds), then press it fully **B** (a shutter click sounds).

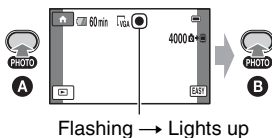

\* Movies are recorded in the [SP] recording mode.

## Playing back recorded movies/still images

**1** Turn the POWER switch **[G]** to turn on your camcorder.

**2** Press **[VIEW IMAGES]** **[I]** (or **[D]**).

The VISUAL INDEX screen appears on the screen. (It may take some time to display the thumbnails.)

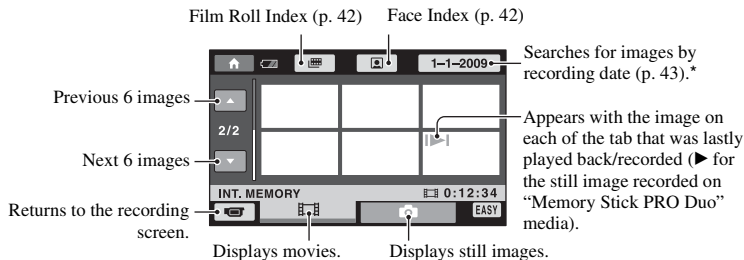

\* When you select [DISC] on [MOVIE MEDIA SET] (p. 26), a disc type appears. You cannot search for movies by recording date.

**3** Start playback.

### Movies:

Touch the **[MOVIE]** tab and the movie to be played back.

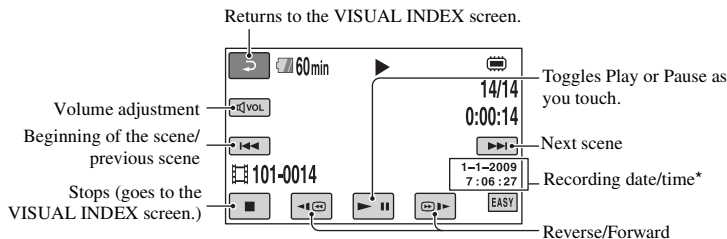

\* The setting of [DATA CODE] is fixed to [DATE/TIME] (p. 82).

## Recording and playing back with ease (Easy Handycam operation) (Continued)

### 💡 Tips

- When playback from the selected movie reaches the last movie, the screen returns to the VISUAL INDEX screen.
- You can slow down the playback speed by touching / during pause.
- You can adjust the volume by touching → adjust with / → during playback.
- You can change the movie media with [MOVIE MEDIA SET] (p. 26).

### Still images:

Touch the tab and the still image to be played back.

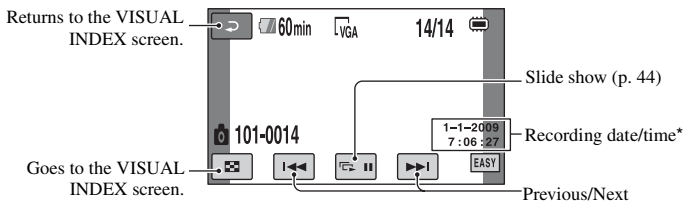

\* The setting of [DATA CODE] is fixed to [DATE/TIME] (p. 82).

### 💡 Tips

- You can switch the still image media with [PHOTO MEDIA SET] (DCR-DVD450E/DVD850E) (p. 26).

## To cancel Easy Handycam operation

Press EASY [A] again. EASY disappears from the screen.

## Menu settings during Easy Handycam operation

Touch  (HOME) [C] (or [B]) to display the menu items available for setup changes (p.16, 77).

### Notes

- Most of the menu items automatically return to the default settings. The settings of some menu items are fixed. For details, see page 78.
- DVD-RW is formatted with VIDEO mode (p. 12).
- You cannot use the  (OPTION) menu.
- Cancel Easy Handycam operation if you want to add effects to images or change settings.

## Invalid buttons during Easy Handycam operation

You cannot use some buttons/functions during Easy Handycam operation since they are automatically set (p. 78). If you set an invalid operation, [Invalid during Easy Handycam operation] appears.

## To view movies on a disc on other devices (Finalize)

To view movies stored on a disc on other devices or a computer, you need to “finalize” the disc. For details on finalizing operation, see page 66.

### Notes

- For DVD-R, DVD+R DL, you cannot reuse the disc or record additional movies onto the disc once you finalize the disc even if the disc has free space.
- You cannot record additional movies on a finalized disc during Easy Handycam operation (p. 73).

# Recording

The images are recorded on the media selected on the media setting (p. 26).

## DCR-DVD150E/DVD650E

In the default setting, movies are recorded on a disc. Still images are recorded on “Memory Stick PRO Duo” media only.

## DCR-DVD450E/DVD850E

In the default setting, both movies and still images are recorded on the internal memory.

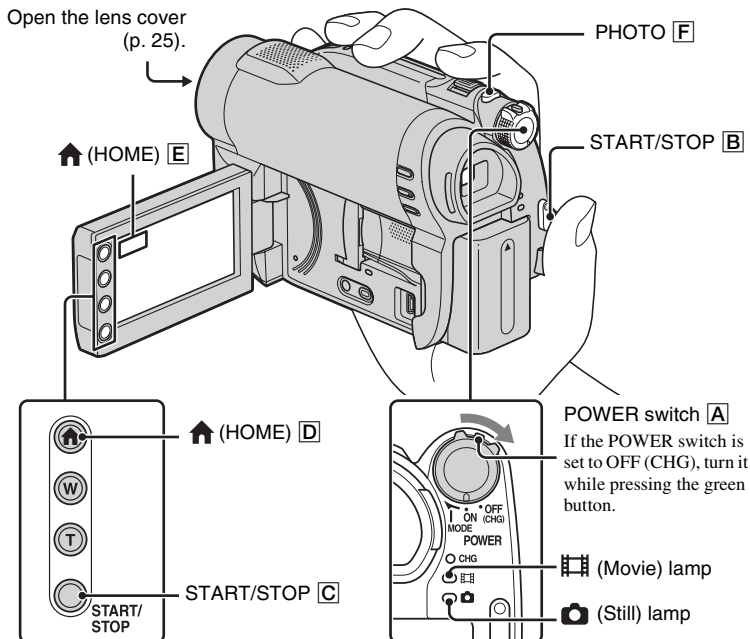

### ⚡ Notes

- If the ACCESS/access lamps (p. 28, 30) are lit or flashing after recording is finished, it means data is still being written onto the media. Do not apply shock or vibration to your camcorder, and do not remove the battery pack or the AC Adaptor.
- In the case that [INT. MEMORY] (DCR-DVD450E/DVD850E) or [MEMORY STICK] is selected on [MOVIE MEDIA SET] (p. 26), when a movie file exceeds 2 GB, the next movie file is created automatically.

### 💡 Tips

- See page 5 for the “Memory Stick PRO Duo” media you can use in your camcorder.

- You can check the free media space for movies by touching (HOME) (or ) → (MANAGE MEDIA) → [MEDIA INFO] (p. 70).

## Movies



- Turn the POWER switch until the (Movie) lamp lights up.

- Press START/STOP (or ).

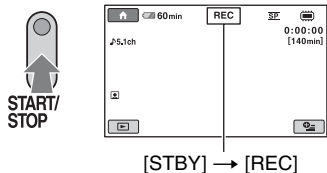

To stop recording, press START/STOP again.

## Still Images



- Turn the POWER switch until the (Still) lamp lights up.

- Press PHOTO lightly to adjust the focus (a beep sounds), then press it fully (a shutter click sounds).

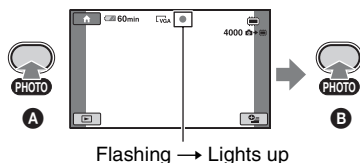

appears next to or . When disappears, the image has been recorded.

### Notes

- You cannot record still images on a disc.

### Tips

- See page 13 for the recordable time of movies, and page 81 for the number of recordable still images.
- appears when [FACE SET] is set to [ON] (the default setting) during movie recording (p. 80).
- You can switch recording between movies and still images by touching (HOME) (or ) → (CAMERA) → [MOVIE] or [PHOTO].
- You can create still images from recorded movies (p. 50).

### Zooming

You can magnify images up to 60 times the original size with the power zoom lever or the zoom buttons on the LCD frame.

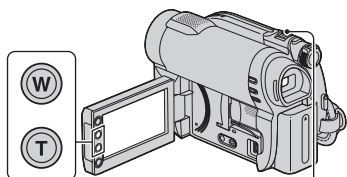

**Wider range of view:**  
(Wide angle)

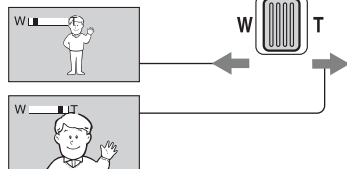

**Close view:** (Telephoto)

Move the power zoom lever slightly for a slower zoom. Move it further for a faster zoom.

#### Notes

- [STEADYSHOT] may not reduce image blurring as desired when the power zoom lever is set to the T (Telephoto) side.
- Be sure to keep your finger on the power zoom lever. If you move your finger off the power zoom lever, the operation sound of the lever may also be recorded.
- You cannot change the zoom speed with the zoom buttons on the LCD frame.
- The minimum possible distance between camcorder and subject while maintaining sharp focus is about 1 cm (about 13/32 in.) for wide angle and about 150 cm (about 59 1/8 in.) for telephoto.

#### Tips

- Using [DIGITAL ZOOM] (p. 79), you can zoom to a level greater than 60×.

### Recording sound with more presence (5.1ch surround recording) (DCR-DVD450E/DVD850E)

Sound picked up by the built-in microphone is converted to 5.1ch surround sound and recorded.

Enjoy realistic sound when playing the movies on devices that support 5.1ch surround sound.

Built-in microphone

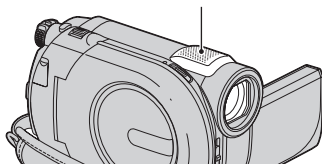

Dolby Digital 5.1 Creator, 5.1ch surround sound  
Glossary (p. 131)

#### Notes



- 5.1ch sound is converted to 2ch when played back on your camcorder.

#### Tips

- You can select the recording sound, [5.1ch SURROUND] or [2ch STEREO] ([AUDIO MODE], p. 79).

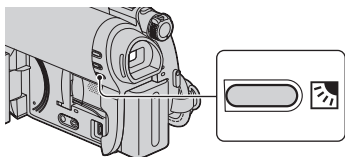
## Adjusting the exposure for backlit subjects



To adjust the exposure for backlit subjects, press  (Backlight) to display . To cancel the back light function, press  (Backlight) again.

## Recording in mirror mode

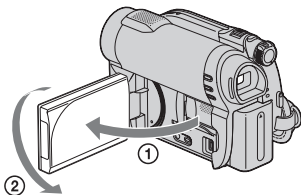

Open the LCD panel 90 degrees to the camcorder (①), then rotate it 180 degrees to the lens side (②).

### Tips

- A mirror-image of the subject appears on the LCD screen, but the image will be normal when recorded.
- When recording in mirror mode, the images are not displayed in the viewfinder.

# Playback

You can play back images recorded on the media selected in the media setting (p. 26).

## DCR-DVD150E/DVD650E

In the default setting, movies on a disc are played. Still images are recorded and played on “Memory Stick PRO Duo” media only.

## DCR-DVD450E/DVD850E

In the default setting, images in the internal memory are played.

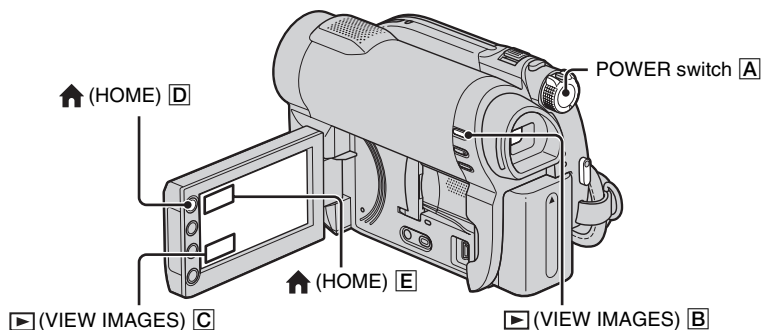

**1** Turn the **POWER switch** **A** to turn on your camcorder.

**2** Press **▶ (VIEW IMAGES)** **B** (or **C**).

The VISUAL INDEX screen appears on the screen. (It may take some time to display the thumbnails.)

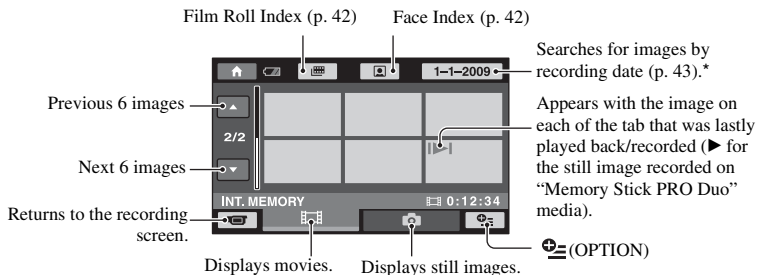

\* When you select [DISC] on [MOVIE MEDIA SET] (p. 26), a disc type appears. You cannot search for movies by recording date.

### 3 Start playback.

#### Movies



Touch the tab and the movie to be played back.

When playback from the selected movie reaches the last movie, the screen returns to the VISUAL INDEX screen.

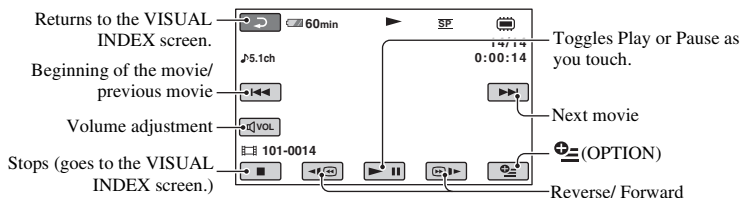

#### Tips

- Touch / during pause to play back movie slowly.
- When playing movies from the internal memory (DCR-DVD450E/DVD850E) or from “Memory Stick PRO Duo” media, one touch of / makes the movie reverse/fast forward about 5 times faster than normal, 2 touches about 10 times, 3 touches about 30 times, and 4 touches about 60 times faster.
- When playing the movies on a disc, one touch of / makes the movie reverse/fast forward about 5 times faster than normal, 2 touches about 10 times faster (about 8 times faster for a DVD+RW).

#### Still Images



Touch the tab and the still image to be played back.

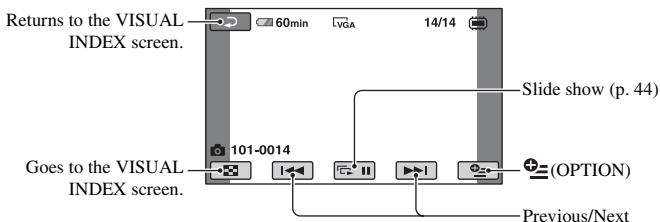

## Playback (Continued)

### To adjust the sound volume of movies

While playing back movies, touch → adjust with / → .

You can adjust the sound volume from the OPTION MENU.

#### Tips

- You can switch screen to the VISUAL INDEX screen by touching (HOME) (or ) → (VIEW IMAGES) → [VISUAL INDEX].

### Searching for scenes with pinpoint accuracy (Film Roll Index)

Movies can be divided by a set time, and the first scene of each division is displayed on the INDEX screen. You can start playing back a movie from the selected scene. Select beforehand media which contains the movie you want to play back (p. 26).

#### 1 Press (VIEW IMAGES) on your camcorder.

The VISUAL INDEX screen appears.

#### 2 Touch (Film Roll Index).

Previous/Next movie

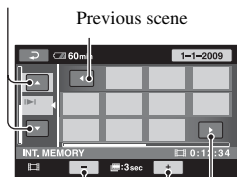

Changes the interval of scenes.

#### 3 Touch / to select the desired movie.

#### 4 Touch / to search for the desired scene, then touch the scene you want to play back.

Playback starts from the selected scene.

#### Tips

- You can display the Film Roll Index screen by touching (HOME) → (VIEW IMAGES) → [FILM ROLL].

### Searching for desired scenes by a face (Face Index)

The detected face images during recording are displayed on the INDEX screen.

You can play back the movie from the selected face image.

Select beforehand media which contains the movie you want to play back (p. 26).

#### 1 Press (VIEW IMAGES) on your camcorder.

The VISUAL INDEX screen appears.

#### 2 Touch (Face Index).

Previous/Next movie

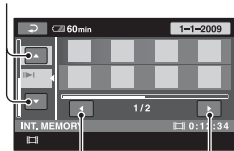

Previous/Next face image

#### 3 Touch / to select the desired movie.

## 4 Touch ◀/▶ to search for the desired face image, then select the face image of the scene you want to play back.

Playback starts from the selected scene.

### Notes

- Faces may not be detected depending on recording conditions.  
Example: People wearing glasses or hats, or not facing towards the camera.
- Set [ FACE SET ] to [ON] (the default setting) before recording to play back movies from [ FACE ] (p. 80). Face Index may not appear properly if no face was detected.

### Tips

- You can display the Face Index screen by touching (HOME) → (VIEW IMAGES) → [ FACE ].

## Searching for desired images by date (Date Index)



You can efficiently search for desired images by date.  
Select beforehand media which contains the movie you want to play back (p. 26).

### Notes

- You cannot use the Date Index with the disc, and still images on the “Memory Stick PRO Duo” media.

## 1 Press (VIEW IMAGES) on your camcorder.

The VISUAL INDEX screen appears.

## 2 To search for movies, touch the tab. To search for still images, touch the tab.

## 3 Touch the date button at the upper right corner of the screen.

The recording dates of images are displayed on the screen.

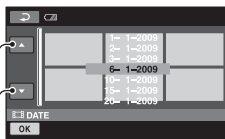

Previous/Next date

## 4 Touch /◁ to select the recording date of the desired images, then touch .

The images recorded on the selected date are displayed on the screen.

### Tips

- On the Film Roll Index screen or the Face Index screen, you can display the Date Index function by following the steps 3 to 4.

## Using PB zoom

You can magnify still images from about 1.1 to 5 times the original size. Magnification can be adjusted with the power zoom lever or the zoom buttons on the LCD frame.

## Playback (Continued)

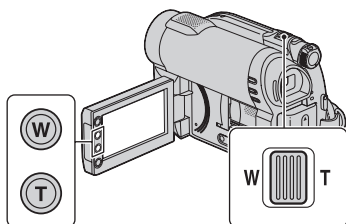

- 1 Play back the still image you want to magnify.
- 2 Magnify the still image with T (Telephoto).  
The screen is framed.
- 3 Touch the screen at the point you want to display in the center of the displayed frame.
- 4 Adjust the magnification with W (Wide angle)/T (Telephoto).

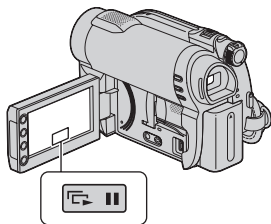

To cancel, touch .

### Playing back a series of still images (Slide show)



Touch  on the still image playback screen.





The slide show begins from the selected still image.

Touch  to stop the slide show. To restart, touch  again.

### Notes

- You cannot operate playback zoom during slide show.

### Tips

- You can also play back the slide show by touching  (OPTION) →  tab → [SLIDE SHOW] on the VISUAL INDEX screen.
- While playing back still images, you can set continuous slide show playback by touching  (OPTION) →  tab → [SLIDE SHOW SET]. As the default setting is [ON],  is displayed on the LCD screen and your camcorder repeats a slide show of still images. If you set [SLIDE SHOW SET] to [OFF], your camcorder plays the still images in slide show mode once, starting from the selected still image.

# Playing the images on a TV

Connect your camcorder to the input jack of a TV or VCR using the A/V connecting cable **1** or an A/V connecting cable with S VIDEO **2**. Connect your camcorder to the wall outlet (wall socket) using the supplied AC Adaptor for this operation (p. 20). Refer also to the instruction manuals supplied with the devices to be connected.

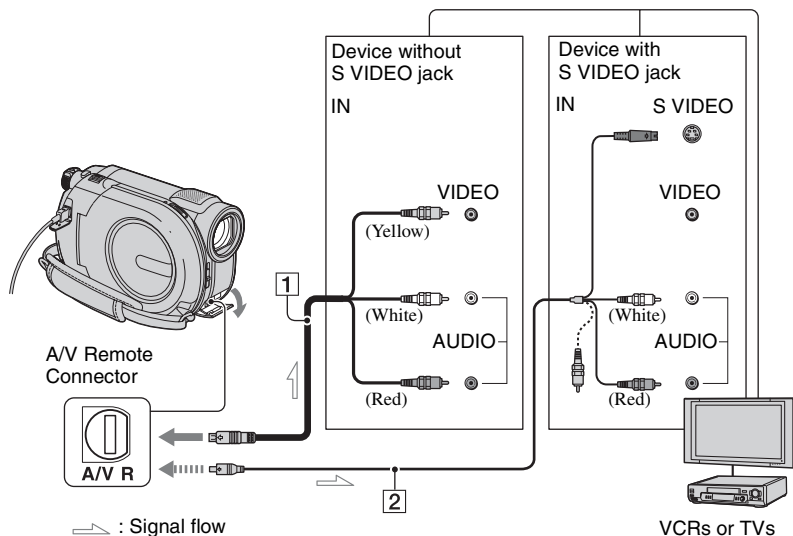

## **1** A/V connecting cable (supplied)

Connect to the input jack of the other device.

## **2** A/V connecting cable with S VIDEO (sold separately)

When connecting to the other device via the S VIDEO jack, by using an A/V connecting cable with S VIDEO (sold separately), higher quality images can be produced than with an A/V connecting cable. Connect the white and red plugs (left/right audio) and the S VIDEO plug (S VIDEO channel) of the A/V connecting cable with S VIDEO (sold separately). The yellow plug connection is not necessary. Connecting only the S VIDEO plug will not output audio.

## When your TV is connected to a VCR

Connect your camcorder to the LINE IN input on the VCR. Set the input selector on the VCR to LINE (VIDEO 1, VIDEO 2, etc.), if the VCR has an input selector.

## To set the aspect ratio according to the connected TV (16:9/4:3)

Change the setting according to the screen aspect ratio of the TV you will view images on.

- 1 Turn on your camcorder.
- 2 Touch **HOME** → **SETTINGS** → [OUTPUT SETTINGS] → [TV TYPE] → [16:9] or [4:3] → **OK**.

## Playing the images on a TV (Continued)

### 🔊 Notes

- When you set [TV TYPE] to [4:3], the image quality may deteriorate. Also, when the recorded image's aspect ratio switches between 16:9 (wide) and 4:3, the image may jitter.
- When you play back an image recorded in 16:9 (wide) aspect ratio on a 4:3 TV not compatible with the 16:9 (wide) signal, set [TV TYPE] to [4:3].

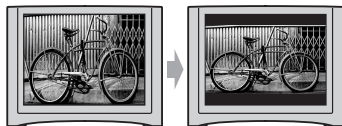

### When your TV is monaural (When your TV has only one audio input jack)

Connect the yellow plug of the A/V connecting cable to the video input jack and connect the white (left channel) or the red (right channel) plug to the audio input jack of your TV or VCR.

### 💡 Tips

- You can display the counter on the TV screen by setting [DISP OUTPUT] to [V-OUT/PANEL] (p. 84).

### If your TV/VCR has a 21-pin adaptor (EUROCONNECTOR)

Use a 21-pin adaptor (sold separately) to view playback images.

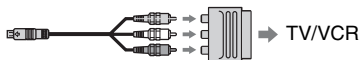



## (OTHERS) category

This category enables you to edit images on the media, or copy them onto your computer for viewing, editing or creating an original DVD.

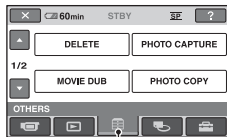

 (OTHERS) category

### Notes

- You can select the media of the image to be edited by touching  (HOME) →  (MANAGE MEDIA) → [MOVIE MEDIA SET]/[PHOTO MEDIA SET] (p. 26).

### Item list

#### DELETE

You can delete images on the media (p. 48).

#### PHOTO CAPTURE (DCR-DVD450E/ DVD650E/DVD850E)

You can capture a selected scene from a recorded movie as a still image (p. 50).

#### MOVIE DUB (DCR-DVD450E/DVD650E/ DVD850E)

You can dub movies recorded on the internal memory (DCR-DVD450E/DVD850E) or “Memory Stick PRO Duo” media (DCR-DVD650E/DVD850E) to a disc (p. 52).

#### PHOTO COPY (DCR-DVD450E/ DVD850E)

You can copy still images recorded on the internal memory to “Memory Stick PRO Duo” media (p. 53).

#### EDIT

You can edit the images on the media (p. 55).

#### PLAYLIST EDIT

You can create and edit a Playlist (p. 59).

#### USB CONNECT

You can connect your camcorder to a computer or another device using the USB cable (p. 93).

#### BATTERY INFO

You can check the approximate remaining battery level (p. 64).

# Deleting images

## Notes

- You cannot restore images once they are deleted.

## Tips

- You can select up to 100 images at one time.

## Deleting movies



Select beforehand the media which contains the movie you want to delete (p. 26).

## Notes

- When you select [DISC] on [MOVIE MEDIA SET] (p. 26), you cannot delete movies during Easy Handycam operation (p. 32). Cancel Easy Handycam operation first.

**1** Touch **HOME** →  
**OTHERS** → **[DELETE]**.

**2** Touch **[DELETE]**.

**3** Touch **[DELETE]**.

**4** Touch the movie to be deleted.



The selected movie is marked with ✓. Press and hold the movie on the screen to confirm.

Touch **[RETURN]** to return to the previous screen.

**5** Touch **[OK]** → **[YES]**.

**6** When **[Completed.]** appears, touch **[OK]**.

## To delete all movies at one time



- In step **3**, touch **[DELETE ALL]**.
- Touch **[YES]** → **[YES]**.
- When **[Completed.]** appears, touch **[OK]**.

## To delete all the movies recorded on the same day at one time



- In step **3**, touch **[DELETE by date]**.

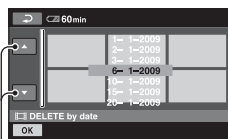

Previous/Next date

- Touch **[UP]**/**[DOWN]** to select the recording date of the desired movies, then touch **[OK]**.

The movies recorded on the selected date are displayed on the screen.

Touch the movie on the screen to confirm.

Touch **[RETURN]** to return to the previous screen.

- Touch **[OK]** → **[YES]**.
- When **[Completed.]** appears, touch **[OK]**.

## To delete the most recently recorded movie



- 1 In step 3, touch [LAST SCENE DEL].
- 2 Touch [OK] → [YES].
- 3 When [Completed.] appears, touch [OK].

You cannot delete the most recently recorded movie:

- if you remove the disc from your camcorder after recording.
- if you turn off your camcorder after recording.

### Notes

- Do not remove the battery pack or the AC Adaptor from your camcorder while deleting movies.
- Do not remove the “Memory Stick PRO Duo” media while deleting movies from the “Memory Stick PRO Duo” media.
- If the deleted movie is included in a Playlist (p. 59), the movie is deleted also from the Playlist.
- You cannot delete protected movies. Undo the protection of the movies to delete them before you try to delete them (p. 55).
- Even if you delete unnecessary movies from the disc, the remaining disc capacity may not increase as much as you can make additional recording.

### Tips

- To delete all images recorded on the media and recover all the recordable space of the media, format the media (p. 71).
- You can delete a movie when viewing it by touching [OPTION].

## Deleting still images



Select beforehand the media which contains the still image you want to delete (p. 26).

- 1 Touch [HOME] → [OTHERS] → [DELETE].

- 2 Touch [DELETE].

- 3 Touch [DELETE].

- 4 Touch the still image to be deleted.

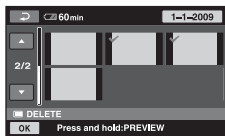

The selected still image is marked with ✓.

Press and hold the still image on the screen to confirm.

Touch [RETURN] to return to the previous screen.

- 5 Touch [OK] → [YES].

- 6 When [Completed.] appears, touch [OK].

## To delete all still images at one time



- 1 In step 3, touch [DELETE ALL].
- 2 Touch [YES] → [YES].
- 3 When [Completed.] appears, touch [OK].

## Deleting images (Continued)

To delete all the still images recorded on the same day at one time



- ① In step 3, touch [ DELETE by date ].

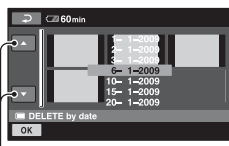

Previous/Next date

- ② Touch / to select the recording date of the desired still images, then touch .

The still images recorded on the selected date are displayed on the screen.

Touch the still image on the screen to confirm.

Touch to return to the previous screen.

- ③ Touch → [YES].
- ④ When [Completed.] appears, touch .

### Notes

- You cannot delete protected still images. Undo the protection of the still images to delete them before you try to delete them (p. 57).

### Tips

- To delete all images recorded in the internal memory (DCR-DVD450E/DVD850E) or “Memory Stick PRO Duo” media, and recover all the recordable space of the media, format the media (p. 71).
- You can delete a still image when viewing it by touching (OPTION).

## Capturing a still image from a movie (DCR-DVD450E/DVD650E/DVD850E)

You can capture a still image at any point during movie playback.

Select the media which contains the movies beforehand, and the media where you want to save the still images (p. 26).

When you select [MEMORY STICK] to save the still images, insert “Memory Stick PRO Duo” media beforehand.

The media you can select depends on your camcorder model. See the table below.

Model	Movies in		Still images in
DCR-DVD450E		→	
		→	
DCR-DVD650E		→	
		→	
DCR-DVD850E		→	
		→	
		→	
		→	
		→	
		→	

### Notes

- Using the AC Adaptor as the power source is recommended to prevent the power from being turned off during operation.

- 1 Touch (HOME) → (OTHERS) → [PHOTO CAPTURE].

The [PHOTO CAPTURE] screen appears.

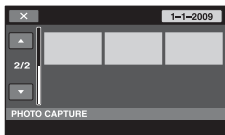

## 2 Touch the movie that you want to play back and capture an image from.

The selected movie is played back.

## 3 Touch to pause at the point where you want to capture.

The movie pauses.

Play and pause toggles as you press



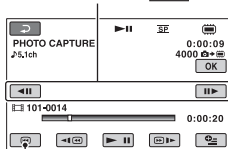

Adjusts the capturing point with more precision after the capturing point has been selected with .





Returns to the beginning of the selected movie.

## 4 Touch .

 appears while the still image is captured and stored on the media you selected.

To capture another still image, touch  and repeat from step 2.

To finish the operation, touch  → .









## Notes

- The media where you want to save still images has to have enough free space.
- Recording date and time of created still images are the same as the recording date and time of the movies.
- If the movies do not have data code, recording date and time of still images are saved as the time you create them from the movies.

# Dubbing/copying images to media within your camcorder (DCR-DVD450E/DVD650E/DVD850E)

## Dubbing movies (DCR-DVD450E/DVD650E/DVD850E)

You can dub movies from the internal memory (DCR-DVD450E/DVD850E) or “Memory Stick PRO Duo” media (DCR-DVD650E/DVD850E) to a disc. Insert a disc in your camcorder beforehand. The media you can select depends on your camcorder model. See the table below.



Model	From	To
DCR-DVD450E		
DCR-DVD650E		
DCR-DVD850E	 	 

### Notes

- Using the AC Adaptor as the power source is recommended to prevent the power from being turned off during operation.
- To display the recording date and time when playing back a disc on another device, set [SUB-T DATE] (p. 85) to [ON] (the default setting) before dubbing movies.

### Tips

- To check dubbed movies on the disc, select [DISC] on [MOVIE MEDIA SET] (p. 26).

- Touch  (HOME) →  (OTHERS) → [MOVIE DUB]. Or, press DUBBING on your camcorder (DCR-DVD450E/DVD850E).

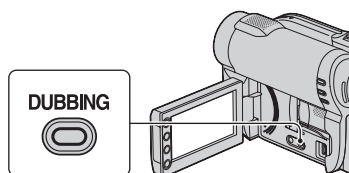

The [MOVIE DUB] screen appears.

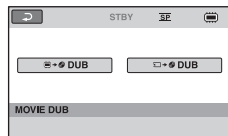

- DCR-DVD850E:  
Touch media which contains the movie to be dubbed.

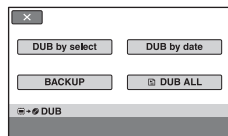



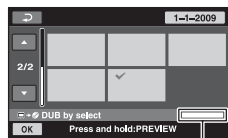

DCR-DVD450E/DVD650E:  
Step 2 is unnecessary. Go to step 3.

- Touch [DUB by select].

- Touch the movie to be dubbed.



- \* : Used
-  (green): To be used to save the selected movie
- : Free space

The selected movie is marked with . Press and hold the movie on the screen to confirm.

Touch  to return to the previous screen.

If the disc space is not sufficient to record the entire movie, [Not enough memory space.] appears.

---

## 5 Touch [OK] → [YES].

---

## 6 When [Completed.] appears, touch [OK].

---

### To dub all the movies recorded on the same day at one time

- ① In step 3, touch [DUB by date].

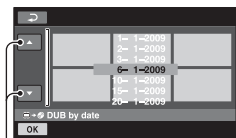

Previous/Next date

- ② Touch ▲/▼ to select the recording date of the desired movies, then touch [OK].

The movies recorded on the selected date are displayed on the screen.

Touch the movie on the screen to confirm.

Touch [◀] to return to the previous screen.

- ③ Touch [OK] → [YES].  
If the disc space is not sufficient to record the entire movie, [Not enough memory space.] appears.
- ④ When [Completed.] appears, touch [OK].

### To dub all movies in a Playlist (p. 59)

- ① In step 3, touch [DUB ALL].  
If the disc space is not sufficient to record the entire movie, [Not enough memory space.] appears.

- ② Touch [YES].  
③ When [Completed.] appears, touch [OK].

### To back up movies that have not been backed up yet

- ① In step 3, touch [BACKUP].  
② Touch [Backs up unbacked up movies.] → [YES].  
③ When [Completed.] appears, touch [OK].  
If the disc space is not sufficient to record the entire movie, [Disc is full.] appears, and the number of one-sided discs required will be displayed. Prepare discs, and repeat from step ①.

### Notes

- If movies are backed up on 2 or more discs, the movie recorded at the end of each disc is divided automatically to fit in the full disc capacity.

### Tips

- In step 3, by touching [BACKUP] → [Backup starts from the first movie. Previous backup history will be deleted.], you can back up all movies, including movies that have been backed up previously. Your camcorder will keep a backup history of movies only when they are saved with the [BACKUP] function.

### Copying still images (DCR-DVD450E/DVD850E)

You can copy still images from the internal memory to “Memory Stick PRO Duo” media.

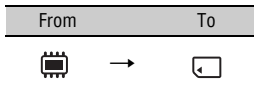

Insert “Memory Stick PRO Duo” media into your camcorder beforehand.

### Notes

- Using the AC Adaptor as the power source is recommended to prevent the power from being turned off during operation.

# Dubbing/copying images to media within your camcorder (DCR-DVD450E/DVD650E/DVD850E) (Continued)

## 💡 Tips

- To check the copied still images, select [MEMORY STICK] on [PHOTO MEDIA SET] (p. 27).

- 
- 1 Touch **↑** (HOME) → **☰** (OTHERS) → [PHOTO COPY].

The [PHOTO COPY] screen appears.

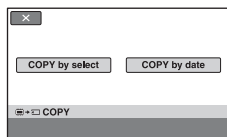

- 
- 2 Touch [COPY by select].

- 
- 3 Touch the still image to be copied.

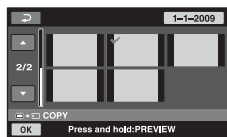

The selected still image is marked with ✓.

Press and hold the still image on the screen to confirm.

Touch **←** to return to the previous screen.

- 
- 4 Touch **OK** → [YES].

- 
- 5 When [Completed.] appears, touch **OK**.
- 

## To copy all the still images recorded on the same day at one time

- ① In step 2, touch [COPY by date].

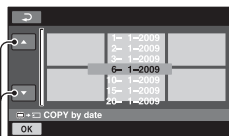

Previous/Next date

- ② Touch **↑**/**↓** to select the recording date of the desired still images, then touch **OK**.

The still images recorded on the selected date are displayed on the screen.

Touch the still image on the screen to confirm.

Touch **←** to return to the previous screen.

- ③ Touch **OK** → [YES].
- ④ When [Completed.] appears, touch **OK**.

# Protecting images

You can protect recorded movies or still images from accidental deletion.

## Tips

- You can select up to 100 images at one time.

## Protecting movies



Select beforehand the media which contains the movie you want to protect (p. 26).

**1** Touch **↑** (HOME) →  
**☰** (OTHERS) → [EDIT].

**2** Touch **[PRT.]**.

**3** Touch **[PRT.]**.

**4** Touch the movie to be protected.

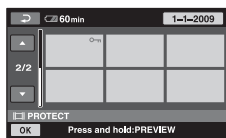

The selected movie is marked with **○**.

Press and hold the movie on the screen to confirm.

Touch **←** to return to the previous screen.

**5** Touch **[OK]** → [YES].

**6** When [Completed.] appears, touch **[OK]**.

## To unprotect movies



In step 4, touch the movie marked with **○**.  
**○** disappears.

To protect all the movies recorded on the same day at one time



① In step 3, touch **[PRT.]** by date.

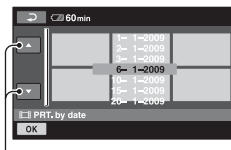

Previous/Next date

② Touch **↑** / **↓** to select the recording date of the desired movies, then touch **[OK]**.

The movies recorded on the selected date are displayed on the screen.

Touch the movie on the screen to confirm.

Touch **←** to return to the previous screen.

③ Touch **[OK]** → [ON].

④ When [Completed.] appears, touch **[OK]**.

## Protecting images (Continued)

### To unprotect all the movies recorded on the same day at one time

In step ②, select the recording date of the desired movies, then touch **[OK]** → **[OFF]**. When **[Completed.]** appears, touch **[OK]**.

#### ⚡ Notes

- Do not remove the battery pack or the AC Adaptor from your camcorder while protecting movies.
- Do not remove the “Memory Stick PRO Duo” media while protecting movies from the “Memory Stick PRO Duo” media.
- Formatting (p. 71) deletes even protected movies.

#### 💡 Tips

- You can protect a movie when viewing it by touching **[OPTION]**.

## Protecting still images



Select beforehand the media which contains the still images you want to protect (p. 26).

---

**1** Touch **[HOME]** → **[OTHERS]** → **[EDIT]**.

---

**2** Touch **[PROTECT]**.

---

**3** Touch **[PROTECT]**.

---

**4** Touch the still image to be protected.

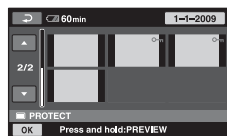

The selected still image is marked with **[OK]**.

Press and hold the image on the screen to confirm.

Touch **[RETURN]** to return to the previous screen.

---

**5** Touch **[OK]** → **[YES]**.

---

**6** When **[Completed.]** appears, touch **[OK]**.

---

## To unprotect still images



In step 4, touch the still image marked with . disappears.

## To protect all the still images recorded on the same day at one time



① In step 3, touch [ PRT. by date].

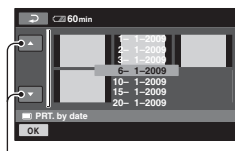

Previous/Next date

② Touch / to select the recording date of the desired still images, then touch .

The still images recorded on the selected date are displayed on the screen.

Touch the still image on the screen to confirm.

Touch to return to the previous screen.

③ Touch → [ON].

④ When [Completed.] appears, touch .

## To unprotect all the still images recorded on the same day at one time

In step ②, select the recording date of the desired still images, then touch → [OFF]. When [Completed.] appears, touch .

### Notes

- Do not remove the battery pack or the AC Adaptor from your camcorder while protecting still images.

- Do not remove the “Memory Stick PRO Duo” media while protecting still images from the “Memory Stick PRO Duo” media.
- Formatting (p. 71) deletes even protected still images.

### Tips

- You can protect a still image when viewing it by touching (OPTION).

# Dividing movies



Select beforehand the media which contains the movie you want to divide (p. 26).

---

**1** Touch (HOME) →  
 (OTHERS) → [EDIT].

---

**2** Touch [] [DIVIDE].

---

**3** Touch the movie that you want to divide.

The selected movie is played back.

---

**4** Touch at the point where you want to divide.

The movie pauses.

Play and pause toggles as you press



Adjusts the dividing point with more precision after the dividing point has been selected with .

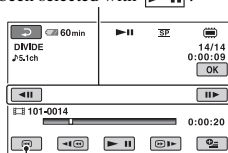

Returns to the beginning of the selected movie.

---

**5** Touch → [YES].

---

**6** When [Completed.] appears, touch .

## Notes

- You cannot restore movies once they are divided.
- Do not remove the battery pack or the AC Adaptor from your camcorder while dividing movies.
- Do not remove the “Memory Stick PRO Duo” media while dividing movies in the “Memory Stick PRO Duo” media.
- When you select [INT. MEMORY] (DCR-DVD450E/DVD850E) or [MEMORY STICK] on [MOVIE MEDIA SET] (p. 26), and the divided original movie is included in a Playlist, the movie in the Playlist will also be divided. When you select [DISC] on [MOVIE MEDIA SET] (p. 26), the movie in a Playlist is not divided.
- A slight difference may occur from the point where you touch and the actual dividing point, as your camcorder selects the dividing point based on about half-second increments.
- You cannot divide protected movies. Undo the protection of the movies to divide them before you try to divide them (p. 55).

## Tips

- You can divide a movie when viewing it by touching (OPTION).
- The images recorded on your camcorder are called “original.”

# Creating the Playlist



A Playlist is a list showing thumbnails of the movies that you have selected. The original scenes are not changed even though you edit or delete the movies in the Playlist.

Select beforehand the media to use to create, play, or edit a Playlist (p. 26).

## Tips

- To a Playlist, you can add a maximum of 99 movies on the internal memory (DCR-DVD450E/DVD850E) or “Memory Stick PRO Duo” media, or 999 movies on a disc.
- The images recorded on your camcorder are called “original.”

**1** Touch (HOME) → (OTHERS) → [PLAYLIST EDIT].

**2** Touch [ADD].

**3** Touch the movie to be added to the Playlist.

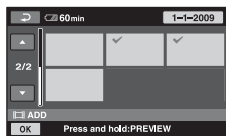

The selected movie is marked with . Press and hold the movie on the screen to confirm. Touch to return to the previous screen.

**4** Touch [OK] → [YES].

**5** When [Completed.] appears, touch [OK].

## To add all the movies to the Playlist



- ① In step 2, touch [ADD ALL].
- ② Touch [YES] → [YES].
- ③ When [Completed.] appears, touch [OK].

## To add all the movies recorded on the same day at one time



- ① In step 2, touch [ADD by date].

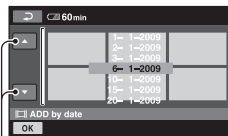

Previous/Next date

- ② Touch / to select the recording date of the desired movies, then touch [OK]. The movies recorded on the selected date are displayed on the screen. Touch the movie on the screen to confirm. Touch to return to the previous screen.
- ③ Touch [OK] → [YES].
- ④ When [Completed.] appears, touch [OK].

## Creating the Playlist (Continued)

### Notes

- Do not remove the battery pack or the AC Adaptor from your camcorder while adding the movies.
- Do not remove the “Memory Stick PRO Duo” while adding movies in the “Memory Stick PRO Duo” media.
- You cannot add still images to a Playlist.

### Tips

- You can add a movie when viewing it by touching  (OPTION).
- You can copy the Playlist to a disc as it is, by using the supplied software.

## Playing the Playlist



Select beforehand the media to use to create, play or edit a Playlist (p. 26).

### 1 Touch (HOME) → (VIEW IMAGES) → [PLAYLIST].

The movies in the Playlist screen appear.

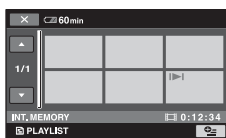





### 2 Touch the movie from which you want to play back.

The Playlist is played back from the selected movie to the end, then the screen returns to the Playlist screen.

### To erase unnecessary movies from the Playlist





- ① Touch  (HOME) →  (OTHERS) → [PLAYLIST EDIT].
- ② Touch []ERASE].  
To erase all the movies from the Playlist, touch []ERASE ALL] → [YES] → [YES]. Then, when [Completed.] appears, touch .
- ③ Touch the movie to be erased from the Playlist.



The selected movie is marked with .

Press and hold the movie on the screen to confirm.

Touch  to return to the previous screen.

- ④ Touch  → [YES].
- ⑤ When [Completed.] appears, touch .

### Tips

- The original movies are not erased even if you erase movies from the Playlist.

## To change the order within the Playlist



- ① Touch **HOME** → **(OTHERS)** → **[PLAYLIST EDIT]**.
- ② Touch **[MOVE]**.
- ③ Select the movie that you want to move.



The selected movie is marked with ✓.  
Press and hold the movie on the screen to confirm.

Touch **[←]** to return to the previous screen.

- ④ Touch **[OK]**.
- ⑤ Select the destination with **[←]** / **[→]**.

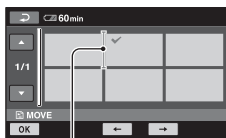

Destination bar

- ⑥ Touch **[OK]** → **[YES]**.
- ⑦ When **[Completed.]** appears, touch **[OK]**.

### 💡 Tips

- When you select multiple movies, the movies are moved following the order appeared in the Playlist.

## To divide a movie in the Playlist



- ① Touch **HOME** → **(OTHERS)** → **[PLAYLIST EDIT]**.
- ② Touch **[DIVIDE]**.
- ③ Touch the movie that you want to divide.  
The selected movie is played back.
- ④ Touch **[▶||]** at the point where you want to divide.  
The movie pauses.

Play and pause toggles as you press



Adjusts the dividing point with more precision after the dividing point has been selected with **[▶||]**.

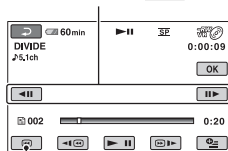

Returns to the beginning of the selected movie.

- ⑤ Touch **[OK]** → **[YES]**.
- ⑥ When **[Completed.]** appears, touch **[OK]**.

### 💡 Notes

- A slight difference may occur from the point where you touch **[▶||]** and the actual dividing point, as your camcorder selects the dividing point based on about half-second increments.

### 💡 Tips

- The original movies are not divided even if you divide the movie in the Playlist.

# Dubbing movies to VCR or DVD/HDD recorders



## Connecting a device with the A/V connecting cable

You can dub movies played back on your camcorder to other recording devices, such as VCRs or DVD/HDD recorders. Connect the device in either of the following ways. Connect your camcorder to the wall outlet (wall socket) using the supplied AC Adaptor for this operation (p. 20). Refer also to the instruction manuals supplied with the devices to be connected.

### Notes

- Since dubbing is performed via analog data transfer, the image quality may deteriorate.

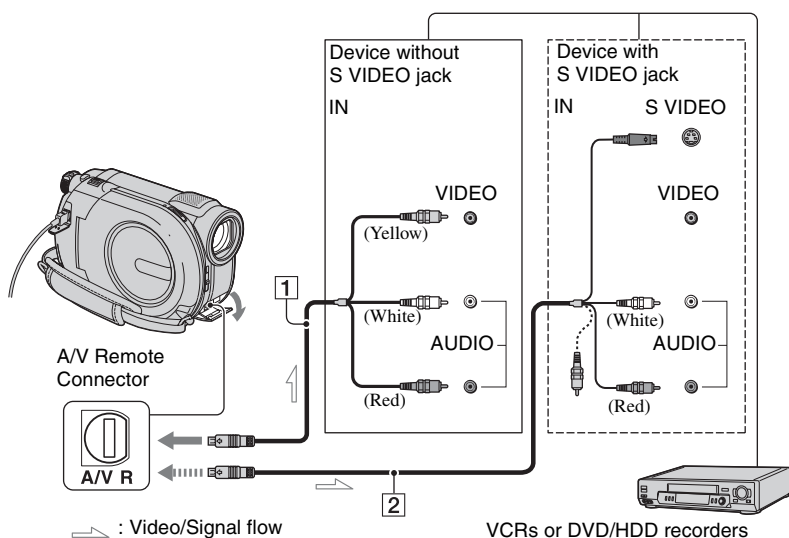

### 1 A/V connecting cable (supplied)

Connect to the input jack of the other device.

### 2 A/V connecting cable with S VIDEO (sold separately)

When connecting to the other device via the S VIDEO jack, by using an A/V connecting cable with S VIDEO (sold separately), higher quality movies can be produced than with an A/V

connecting cable. Connect the white and red plugs (left/right audio) and the S VIDEO plug (S VIDEO channel) of the A/V connecting cable with S VIDEO (sold separately). The yellow plug connection is not necessary. Connecting only the S VIDEO plug will not output audio.

## Notes

- To hide the screen indicators, such as a counter on the screen of the monitor device connected, touch **HOME** → **SETTINGS** → **[OUTPUT SETTINGS]** → **[DISP OUTPUT]** → **[LCD PANEL]** (the default setting) (p. 84).
- To record the date/time and camera settings data, display them on the screen (p. 82).
- When you are connecting your camcorder to a monaural device, connect the yellow plug of the A/V connecting cable to the video input jack, and the red (right channel) or the white (left channel) plug to the audio input jack on the device.

---

### 1 Turn on your camcorder.

---

### 2 Select the media which contains the movie you want to dub (p. 26).

---

### 3 Press **VIEW IMAGES**.

Set **[TV TYPE]** according to the display device (p. 45).

---

### 4 Insert the recording media in the recording device.

If your recording device has an input selector, set it to the input mode.

---

### 5 Connect your camcorder to the recording device (VCR or DVD/HDD recorder) with the A/V connecting cable (supplied) **1** or an A/V connecting cable with S VIDEO (sold separately) **2**.

Connect your camcorder to the input jacks of the recording device.

---

### 6 Start playback on your camcorder, and record it on the recording device.

Refer to the instruction manuals supplied with your recording device for details.

---

### 7 When dubbing is finished, stop the recording device, and then your camcorder.

---

## Connecting a device with the USB cable

By connecting a DVD writer, etc. that is capable of movie dubbing via USB connection to your camcorder, you can dub movies without the decline of their image quality.

Connect your camcorder to the wall outlet (wall socket) using the supplied AC Adaptor for this operation (p. 21). Refer also to the instruction manuals supplied with the devices to be connected.

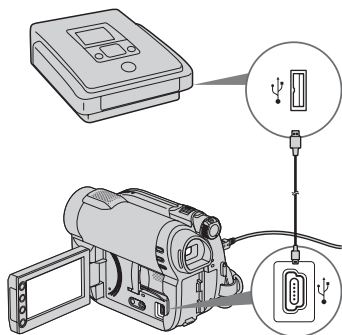

---

### 1 Turn on your camcorder.

- 
- 2** Connect the  $\Psi$  (USB) jack of your camcorder to a DVD writer, etc. using the supplied USB cable (p. 126).

The [USB SELECT] screen appears on the camcorder screen.

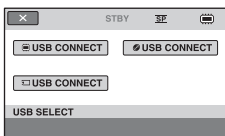

- 
- 3** Touch media which contains the movie to be dubbed.

- 
- 4** Start recording on the connected device.

Refer to the instruction manuals supplied with the connected device for details.

- 
- 5** When dubbing is finished, touch [END] → [YES] and disconnect the USB cable.
- 

## Checking battery information



You can check the approximate remaining capacity of the attached battery.

- 
- Touch  $\uparrow$  (HOME) →  $\text{☰}$  (OTHERS) → [BATTERY INFO].

The remaining battery capacity is shown.

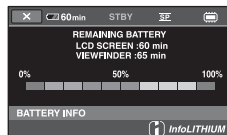

To turn off the display, touch  $\times$ .

---

## (MANAGE MEDIA) category

This category enables you to use the media for various purposes.



 (MANAGE MEDIA) category

### REPAIR IMG.DB F.

You can repair the image database file of the internal memory (DCR-DVD450E/DVD850E) or “Memory Stick PRO Duo” media (p. 75).

## Item list

### MOVIE MEDIA SET

You can select the media for movies (p. 26).

### PHOTO MEDIA SET (DCR-DVD450E/DVD850E)

You can select the media for still images (p. 26).

### FINALIZE

You can enable discs to be played on other devices by finalizing them (p. 66).

### MEDIA INFO

You can display the media information, such as recordable time (p. 70).

### MEDIA FORMAT

You can format the media and recover the recordable free space (p. 71).

### UNFINALIZE

You can unfinalize a disc and record more images on the disc (p. 73).

### DISC SELECT GUIDE

Your camcorder advises you of the right disc for your purpose (p. 74).

# Making the disc compatible with playback on other devices (Finalizing)

Finalizing makes the recorded disc compatible for playback with other devices and DVD drives of computers.

Before finalizing, you can select the style of the DVD menu which displays the movie list (p. 68).

## Finalizing is required depending on the type of disc.

- DVD-RW/DVD-R/DVD+R DL: Finalizing is required.
- DVD+RW: Finalizing is not required, **except in the following cases:**
  - ① To create a DVD menu
  - ② To play back on a computer DVD drive
  - ③ If the disc has a short total recording time (less than 5 min. in HQ mode, 8 min. in SP mode, or 15 min. in LP mode)

## Notes

- Playback compatibility with all devices is not guaranteed.
- No DVD menu is created for DVD-RW (VR mode).

## Operation flow

 To play back a disc in other devices for the first time (p.68)

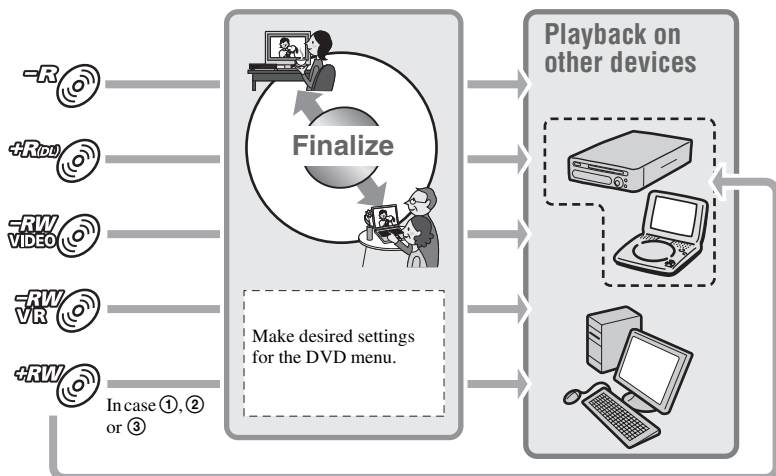

## To add movies to a finalized disc (p.73)

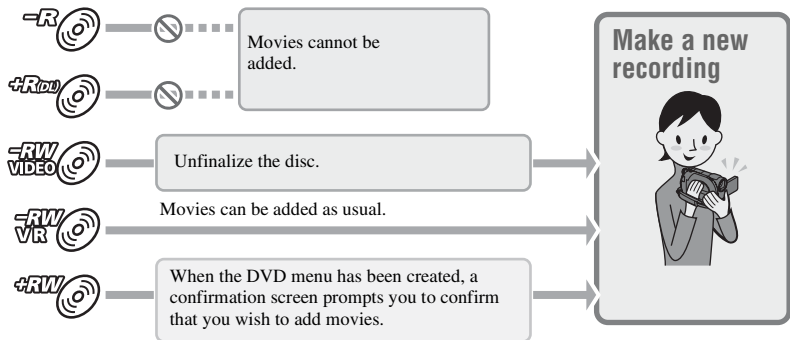

## Notes

- During Easy Handycam operation (p. 32), even when you are using a DVD-RW or DVD+RW, you cannot record additional movies onto the disc after finalizing the disc. Cancel Easy Handycam operation.

## To play back a disc in other devices after adding movies (p.68)

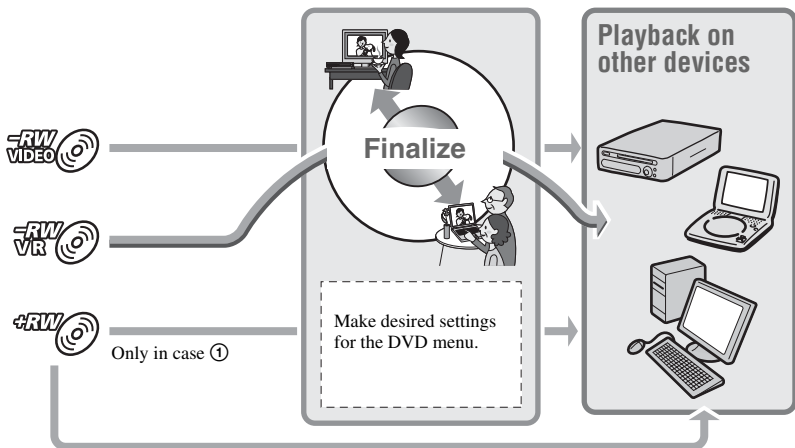

# Making the disc compatible with playback on other devices (Finalizing) (Continued)

## Finalizing a disc

### Notes

- It takes from a minute to a maximum of several hours to finalize a disc. The shorter the amount of material recorded on the disc, the longer it takes for finalizing.

**1** Place your camcorder in a stable place, and connect the AC Adaptor to the DC IN jack on your camcorder.

**2** Turn on your camcorder.

**3** Insert the disc to be finalized.

**4** Touch **HOME** → **MANAGE MEDIA** → **[FINALIZE]**.

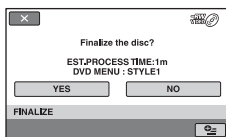

To select a DVD menu style, touch **OPTION** → **[DVD MENU]** (p. 68).

Go to step **5** if you want to finalize the disc using **[STYLE1]** (the default setting).

**5** Touch **[YES]** → **[YES]**.

Finalizing starts.

**6** When finalizing is completed, touch **[OK]**.

### Notes

- When you finalize a double-sided disc, you must finalize each side of the disc individually.
- Do not apply shock or vibration to your camcorder, and do not disconnect the AC Adaptor during finalizing. When you need to disconnect the AC Adaptor, make sure that the power of your camcorder is set to off and disconnect the AC Adaptor after the **Movie** or **Still** lamp goes off. Finalizing restarts when you connect the AC Adaptor and turn on your camcorder again.

### Tips

- When you set to create a DVD menu and finalize the disc, the DVD menu appears for a few seconds while finalizing the disc.
- After the disc is finalized, “**VIDEO**” is attached at the bottom of the disc indicator, such as “**VIDEO**” in the case of DVD-RW (VIDEO mode).

## To select a DVD menu style

- In step **4**, touch **OPTION** → **[DVD MENU]**.
- Select the desired style from 4 types of pattern with **←**/**→**.

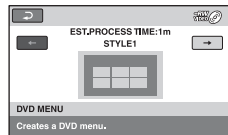

Select **[NO MENU]** if you do not create a DVD menu.

- Touch **[OK]**.

# Playing a disc on other devices

## 🔗 Notes

- During Easy Handycam operation (p. 32), the DVD menu style is fixed to [STYLE1].
- You cannot create a DVD menu for a DVD-RW (VR mode).

## Playing a disc on other devices

Finalizing a disc (p. 66) allows you to view movies recorded by your camcorder on other DVD devices. However, we do not guarantee proper playback on all devices. You can play back DVD+RW on other devices without finalizing the disc.

## 🔗 Notes

- Do not use an 8 cm CD adaptor with an 8 cm DVD as it may cause a malfunction.
- Make sure that a vertically installed device is placed in a position such as that the disc can be placed horizontally.
- On some devices, some discs may not be played back, movies may freeze for an instant between scenes, or some functions may be disabled.

## 💡 Tips

- Devices that support subtitles can display the recording date and time where the subtitles normally appear (p. 85). Refer to the instruction manual of your device.
- If you have created a DVD menu (p. 68), you can select the desired scene in the menu.

## Playing a disc on a computer

If you finalize the disc (p. 66) that was recorded on your camcorder, you can play back the disc on a computer that DVD playback application is installed.

## 🔗 Notes

- Even when you use a DVD+RW, you must finalize the disc (p. 66). Otherwise, a malfunction may occur.
- Make sure that the DVD drive of the computer can play an 8 cm DVD.
- Do not use an 8 cm CD adaptor with an 8 cm DVD as it may cause a malfunction.
- The disc may not be played back, or the movies may not be played smoothly on some computers.
- Movies stored on a disc cannot be copied directly onto a computer to be played back or edited.

## Playing a disc on other devices (Continued)

### 💡 Tips

- For details on operations and procedures, see the “PMB Guide” on the supplied CD-ROM (p. 97).

### The volume label of the disc

The date and time when the disc was first used is recorded. However, the date and time of finalizing may be recorded depending on the operating conditions.

<e.g.>

When the disc was first used at 0:00 am on January 1st 2009:

2009\_01\_01\_00H00M\_AM

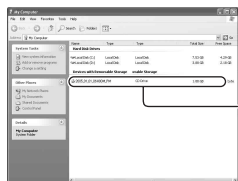

Volume  
label

### 💡 Tips

- Movies on discs are stored in the following folders:
  - DVD-RW (VR mode)  
DVD\_RTAV folder
  - Other discs and modes  
VIDEO\_TS folder

## Checking media information

You can check the remaining recordable time or space of the media selected on [MOVIE MEDIA SET] (p. 26).

---

Touch **↑ (HOME)** → **⏏ (MANAGE MEDIA)** → **[MEDIA INFO]**.

You can check other information by touching **→**.

To turn off the display, touch **⊗**.

---

### 📌 Notes

- The calculation for the space of the internal memory (DCR-DVD450E/DVD850E) and “Memory Stick PRO Duo” media is 1MB = 1,048,576 bytes. The fractions less than 1 MB are discarded when the media space is displayed. Therefore, the total amount of available and unavailable space appears slightly smaller.
- Since there is an image database file area, the used space is not displayed as 0 MB even if you perform [MEDIA FORMAT] (p. 71).

### 💡 Tips

- Only the information for the media selected on [MOVIE MEDIA SET] is displayed. Change the media setting as necessary (p. 26).

# Formatting media

Formatting deletes all images and returns the recording media to its original empty state.

To avoid the loss of important images, dub or copy them on other media (p. 52, 62) before performing [MEDIA FORMAT].

## Formatting the internal memory (DCR-DVD450E/DVD850E) or “Memory Stick PRO Duo” media

**1** Connect the AC Adaptor to the DC IN jack on your camcorder, then connect the power cord (mains lead) to the wall outlet (wall socket).

**2** Turn on your camcorder.

**3** When formatting “Memory Stick PRO Duo” media, insert the “Memory Stick PRO Duo” media to be formatted into your camcorder.

**4** Touch  (HOME) →  (MANAGE MEDIA) → [MEDIA FORMAT] → [INT. MEMORY] (DCR-DVD450E/DVD850E) or [MEMORY STICK].

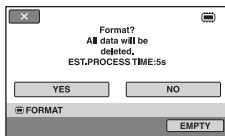

**5** Touch [YES] → [YES].

---

**6** When [Completed.] appears, touch .

---

### Notes



- Do not apply shock or vibration to your camcorder, and do not disconnect the AC Adaptor during formatting.
- Even the images protected against accidental deletion are also deleted (p. 55).
- Do not attempt the following operations when [Executing...] is on the screen:
  - To operate the POWER switch or buttons
  - To remove the “Memory Stick PRO Duo” media when formatting the “Memory Stick PRO Duo” media

## Formatting the disc



**A DVD-R/DVD+R DL cannot be formatted. Replace it with a new disc.**

### If you format a finalized disc

- A DVD-RW (VIDEO mode) returns to the unfinalized state. The disc must be finalized again to view its contents on other devices.
- In the case of a DVD-RW (VR mode)/DVD+RW, formatting deletes all movies on a finalized disc. Even after formatting,  or  will appear on the screen. You do not need to finalize the disc again before playing the disc on other devices.\*
- \* To create the DVD menu on a DVD+RW, finalize the disc again (p. 68).

**1** Connect the AC Adaptor to the DC IN jack on your camcorder, then connect the power cord (mains lead) to the wall outlet (wall socket).



---

**2** Turn on your camcorder.

---

**3** Insert the disc to be formatted into your camcorder.

---

**4** Touch  (HOME) →  (MANAGE MEDIA) → [MEDIA FORMAT] → [DISC].

■ **DVD-RW**

Select the recording format, [VIDEO] or [VR] (p. 12), then touch .

■ **DVD+RW**

Select the aspect ratio of the movie, [16:9 WIDE] or [4:3], then touch .

---

**5** Touch [YES].

---

**6** When [Completed.] appears, touch .

---

 **Notes**

- You cannot format a disc that has been protected on other devices. Cancel the protection with the original device, and then format it.
  - When you format a DVD-RW during Easy Handycam operation (p. 32), the recording format is fixed to VIDEO mode.
- ⚡ **Tips**
- When you format a DVD-RW during Easy Handycam operation (p. 32), the recording format is fixed to VIDEO mode.

# Recording additional movies after finalizing



You can record additional movies on the finalized DVD-RW (VIDEO mode)/DVD+RW discs after the following steps, if the disc has free space.

When using the finalized DVD-RW (VR mode), you can record additional movies on the disc without any additional steps.

## Notes

- You cannot record additional movies on the DVD-R/DVD+R DL after finalizing. Use a new disc.

## When using a DVD-RW (VIDEO mode) (Unfinalizing)

**1** Connect the AC Adaptor to the DC IN jack on your camcorder, then connect the power cord (mains lead) to the wall outlet (wall socket).

**2** Turn on your camcorder.

**3** Insert the finalized disc into your camcorder.

**4** Touch **HOME** → **MANAGE MEDIA** → **[UNFINALIZE]**.

**5** Touch **[YES]** → **[YES]**.

**6** When **[Completed.]** appears, touch **OK**.

## When using a DVD+RW

If you have created a DVD menu (p. 68) during finalizing, you must perform the following steps prior to recording additional movies.

**1** Connect the AC Adaptor to the DC IN jack on your camcorder, then connect the power cord (mains lead) to the wall outlet (wall socket).

**2** Turn the POWER switch to turn on the **[Movie]** lamp.

**3** Insert the finalized disc into your camcorder.

A confirmation screen appears to prompt you to confirm that you wish to record additional movies.

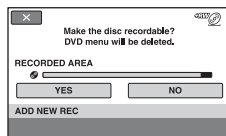

**4** Touch **[YES]** → **[YES]**.

**5** When **[Completed.]** appears, touch **OK**.

## Recording additional movies after finalizing (Continued)



### Notes

- Do not apply shock or vibration to your camcorder, and do not disconnect the AC Adaptor during the operation.
- A DVD menu created during finalizing is deleted.
- For a double-sided disc, perform these steps for each side of the disc.

## Finding the right disc (DISC SELECT GUIDE)

Select the option that is right for you on the screen, then you will be informed of the appropriate disc for your purposes.

---

**1** Touch  (HOME) →  
 (MANAGE MEDIA) → [DISC  
SELECT GUIDE].

---

**2** Touch the option that is right for you on the screen.

If you insert the same type of disc as indicated in [DISC SELECT GUIDE], you can format it with your selected settings (p. 71).

---

# Repairing the image database file



This function checks the image database file and the consistency of movies and still images on the internal memory (DCR-DVD450E/DVD850E), or movies in the “Memory Stick PRO Duo” media, and repairs any inconsistencies found.

## Notes

- Do not apply mechanical shock or vibration to the camcorder during this operation.
- Do not disconnect the AC Adaptor or remove the battery pack.
- While the image database file on the “Memory Stick PRO Duo” media is being repaired, do not remove the “Memory Stick PRO Duo” media.
- Repairing for the internal memory (DCR-DVD450E/DVD850E) and “Memory Stick PRO Duo” media are performed separately.

- 1** Touch **↑ (HOME)** → **📁 (MANAGE MEDIA)** → **[REPAIR IMG.DB F.]** → **[INT. MEMORY]** (DCR-DVD450E/DVD850E) or **[MEMORY STICK]**.

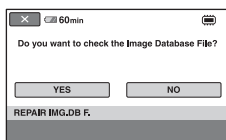

- 2** Touch **[YES]**.

Your camcorder will check the image database file.

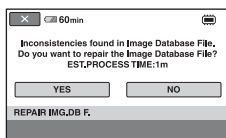

When mismatching is not found, touch **[OK]** to finish the operation.

- 3** Touch **[YES]**.

- 4** When **[Completed.]** appears, touch **[OK]**.

# Preventing data on the internal memory from being recovered (DCR-DVD450E/DVD850E)

[ EMPTY] allows you to write unintelligible data onto the internal memory. In this way, it may become more difficult to recover any original data. When you dispose of or give the camcorder to somebody, it is recommended that you perform [ EMPTY].

## Notes

- If you perform [ EMPTY], all the images are deleted. To avoid the loss of important images, dub or copy them on other media (p. 52, 62) before performing [ EMPTY].
- You cannot perform [ EMPTY] unless you connect the AC Adaptor to the wall outlet (wall socket).
- Disconnect all cables except the AC Adaptor.
- While performing [ EMPTY], do not apply any vibrations or shocks to the camcorder.

---

**1** Connect the AC Adaptor to the DC IN jack on your camcorder, then connect the power cord (mains lead) to the wall outlet (wall socket).

---

**2** Turn on your camcorder.

---

**3** Touch (HOME) → (MANAGE MEDIA) → [MEDIA FORMAT] → [INT. MEMORY].

The screen of formatting the internal memory appears.

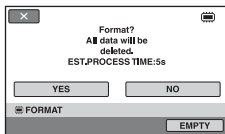

---

**4** Touch [EMPTY].

The [ EMPTY] screen appears.

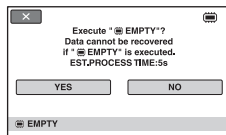

---

**5** Touch [YES] → [YES].

---

**6** When [Completed.] appears, touch .

---

## Notes

- If you stop performing [ EMPTY] while [Executing...] is displayed, be sure to complete the operation by performing [ EMPTY] again before you use the camcorder the next time.

# What you can do with the (SETTINGS) category of the HOME MENU

You can change the recording functions and the operating settings for your convenience.

## Using the HOME MENU

- 1 Turn on your camcorder, then press  (HOME).

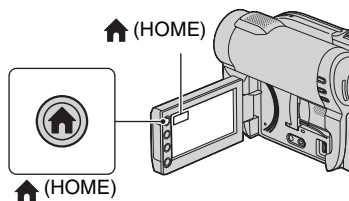

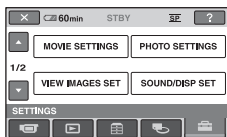

 (SETTINGS) category

- 2 Touch  (SETTINGS).





- 3 Touch the desired setup item.

If the item is not on the screen, touch / to change the page.



- 4 Touch the desired item.

If the item is not on the screen, touch / to change the page.

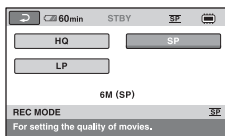



- 5 Change the setting, then touch .

## What you can do with the (SETTINGS) category of the HOME MENU (Continued)

### List of the (SETTINGS) category items

#### MOVIE SETTINGS (p. 79)

Items	Page
<b>REC MODE</b>	79
<b>AUDIO MODE</b> *1	79
<b>WIDE SELECT</b>	79
<b>DIGITAL ZOOM</b>	79
 <b>STEADYSHOT</b>	80
<b>AUTO SLW SHUTTR</b>	80
<b>GUIDEFAME</b>	80
 <b>REMAINING SET</b>	80
 <b>FACE SET</b> *2	80

#### PHOTO SETTINGS (p. 81)

Items	Page
 <b>IMAGE SIZE</b> *2	81
<b>FILE NO.</b>	81
<b>AUTO SLW SHUTTR</b>	80
<b>GUIDEFAME</b>	80

#### VIEW IMAGES SET (p. 82)

Items	Page
<b>DATA CODE</b>	82

#### SOUND/DISP SET\*3 (p. 83)

Items	Page
<b>VOLUME</b> *2	83
<b>BEEP</b> *2	83
<b>LCD BRIGHT</b>	83
<b>LCD BL LEVEL</b>	83
<b>LCD COLOR</b>	83

#### OUTPUT SETTINGS (p. 84)

Items	Page
<b>TV TYPE</b>	84
<b>DISP OUTPUT</b>	84

#### CLOCK/ LANG (p. 84)

Items	Page
<b>CLOCK SET</b> *2	23
<b>AREA SET</b>	84
<b>SUMMERTIME</b>	84
 <b>LANGUAGE SET</b> *2	84

#### GENERAL SET (p. 85)

Items	Page
<b>DEMO MODE</b>	85
<b>CALIBRATION</b>	120
<b>A.SHUT OFF</b>	85
<b>SUB-T DATE</b>	85

\*1 DCR-DVD450E/DVD850E

\*2 You can set these items also during Easy Handycam operation (p. 32).

\*3 [SOUND SETTINGS] during Easy Handycam operation (p. 32)

# MOVIE SETTINGS

(Items for recording movies)



Touch ①, then ②.

If the item is not on the screen, touch ▲/▼ to change the page.

## How to set

🏠 (HOME MENU) → page 77

⊕ (OPTION MENU) → page 86

The default settings are marked with ▶.

## REC MODE (Recording mode)

You can select a recording mode to record a movie with the image quality from 3 levels.

### HQ (HQ)

Records in high quality mode.  
(9M (HQ))

### ▶ SP (SP)

Records in standard quality mode.  
(6M (SP))

### LP (LP)

Increases the recording time (Long Play).  
(3M (LP))

## 🔊 Notes

- If you record in LP mode, the quality of scenes may be degraded, or scenes with quick movements may appear with block noise when you play back the movie.

## 💡 Tips

- See page 13, 31 on the expected recording time of each recording mode.
- You can set the recording mode separately for each media (p. 26).

## AUDIO MODE (DCR-DVD450E/DVD850E)

You can select audio recording format.

### ▶ 5.1ch SURROUND (5.1ch)

Records 5.1ch surround sound.

### 2ch STEREO (2ch)

Records stereo sound.

## WIDE SELECT

When recording images, you can select the aspect ratio according to the TV connected. Refer also to the instruction manuals supplied with your TV.

### ▶ 16:9 WIDE

Records images to the full screen on a 16:9 (wide) TV screen.

### 4:3 (4:3)

Records images to the full screen on a 4:3 TV screen.

## 🔊 Notes

- Set [TV TYPE] correctly according to the TV connected for playback (p. 45).

## DIGITAL ZOOM

You can select the maximum zoom level in case you want to zoom greater than optical zoom magnification. Note that the image quality decreases when you use the digital zoom.

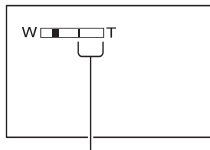

The right side of the bar shows the digital zooming factor. The zooming zone appears when you select the zooming level.

### ▶ OFF

Up to 60× zoom is performed optically.

## MOVIE SETTINGS (Continued)

### 120×

Up to 60 × zoom is performed optically, and after that, up to 120 × zoom is performed digitally.

### 2000×

Up to 60 × zoom is performed optically, and after that, up to 2,000 × zoom is performed digitally.

## STeadySHOT

You can compensate for camera shake. Set [STeadySHOT] to [OFF] () when using a tripod (sold separately), then the image becomes natural. The default setting is [ON].

## AUTO SLW SHUTTR (Auto slow shutter)

When recording in dark places, the shutter speed is automatically reduced to 1/25 second. The default setting is [ON].

## GUIDEFRAmE

You can display the frame and check that the subject is horizontal or vertical by setting [GUIDEFRAmE] to [ON]. The frame is not recorded. Press DISP to make the frame disappear. The default setting is [OFF].

### Tips

- Positioning the subject at the cross point of the guide frame makes a balanced composition.



## REMAInING SET

### ► ON

Always displays the remaining media capacity indicator.

### AUTO

Displays the remaining recording time of movie for about 8 seconds in the following situations.

- When your camcorder recognizes the remaining media capacity when the POWER switch is set to  (Movie).
- When you press DISP to switch the indicator from off to on when the POWER switch is set to  (Movie).
- When you select the movie recording mode on the HOME MENU.



### Notes

- When the remaining recordable time for movies is less than 5 minutes, the indicator stays on the screen.

## FACE SET

The camcorder detects faces automatically during movie recording. The default setting is [ON].

### Face icons and their meanings

- : This icon appears when the setting is [ON].
- : This icon flashes when your camcorder detects a face. The icon stops flashing when the face is recorded in Face Index.
- : This icon appears when faces cannot be recorded in Face Index.

To play back scenes using Face Index, see page 42.

### Notes

- The number of faces detected in a movie is limited.

# PHOTO SETTINGS

(Items for recording still images)



Touch ①, then ②.

If the item is not on the screen, touch / to change the page.

## How to set

(HOME MENU) → page 77

(OPTION MENU) → page 86

The default settings are marked with .

## IMAGE SIZE

### **VGA (0.3M)** ( 640 × 480)

Records the still images of aspect ratio 4:3 clearly.

### **0.2M** ( 640 × 360)

Records still images clearly in the 16:9 (wide) ratio.

## Number of still images recordable on the internal memory (DCR-DVD450E/DVD850E)

You can record up to 9,999 still images on the internal memory. The recordable number of still images varies depending on the recording condition.

## Number of still images recordable on “Memory Stick PRO Duo” media (approx.)

	VGA (0.3M) 640 × 480
512MB	2800
1GB	5700
2GB	11500
4GB	23000
8GB	47000

	VGA (0.3M) 640 × 480
16GB	94000

## Notes

- Numbers in the table are of when using “Memory Stick PRO Duo” media made by Sony Corporation. The recordable number of still images varies depending on the recording conditions or the type of “Memory Stick” media.

## Tips

- You can use “Memory Stick PRO Duo” media with a capacity of 256MB or smaller for recording still images.
- The numbers in the table are of the recordable number of still images of the maximum image size that can be recorded with your camcorder. Check the actual recordable number on the screen when you are recording still images (p. 129).

## FILE NO. (File number)

### SERIES

Assigns file numbers in sequence, even if the “Memory Stick PRO Duo” media is replaced with another one.

### RESET

Assigns individual file numbers for each “Memory Stick PRO Duo” media.

## AUTO SLW SHUTTR (Auto slow shutter)

See page 80.

## GUIDEFAME

See page 80.

# VIEW IMAGES SET

(Items to customize the display)



Touch ①, then ②.

If the item is not on the screen, touch / to change the page.

## How to set

(HOME MENU) → page 77

(OPTION MENU) → page 86

The default settings are marked with ►.

## DATA CODE

During playback, your camcorder displays the information (data code) recorded automatically at the time of recording.

### ► OFF

Data code is not displayed.

### DATE/TIME

Displays the date and time.

### CAMERA DATA

Displays camera setting data.

### DATE/TIME

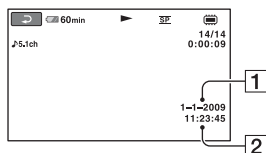

① Date

② Time

## CAMERA DATA

### Movie

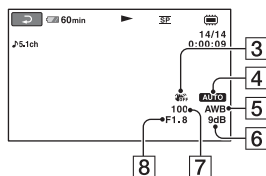

### Still image

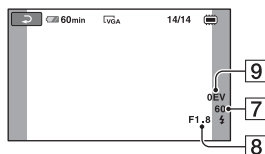

③ SteadyShot off

④ Brightness

⑤ White balance

⑥ Gain

⑦ Shutter speed

⑧ Aperture value

⑨ Exposure

### Tips

- appears for still images recorded on other cameras using a flash.
- The data code is displayed on the TV screen if you connect your camcorder to a TV.
- Depending on the media condition, bars [---:---:---] appear.

# SOUND/DISP SET

(Items to adjust sound and the screen)



Touch ①, then ②.

If the item is not on the screen, touch / to change the page.

## How to set

(HOME MENU) → page 77

(OPTION MENU) → page 86

The default settings are marked with .

## VOLUME



Touch / to adjust the volume.

## BEEP



### ▶ ON

A melody sounds when you start/stop recording, or operate the touch panel.

### OFF

Cancels the melody and shutter sound.

## LCD BRIGHT



You can adjust the brightness of the LCD screen.

① Adjust the brightness with / .

② Touch .

### Tips

- This adjustment does not affect the recorded images in any way.

## LCD BL LEVEL (LCD backlight level)



You can adjust the brightness of the LCD screen's backlight.

### ▶ NORMAL

Standard brightness.

### BRIGHT

Brightens the LCD screen.

### Notes

- When you connect your camcorder to outside power sources, [BRIGHT] is automatically selected for the setting.
- When you select [BRIGHT], battery life is slightly reduced during recording.
- If you open the LCD panel 180 degrees to face the screen outside and close the LCD panel to the camcorder body, the setting becomes [NORMAL] automatically.

### Tips

- This adjustment does not affect the recorded images in any way.

## LCD COLOR



You can adjust the color of the LCD screen with / .



Low intensity High intensity

### Tips

- This adjustment does not affect the recorded images in any way.

# OUTPUT SETTINGS

(Items for when connecting other devices)

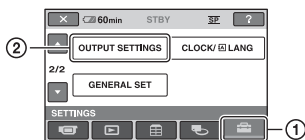

Touch ①, then ②.

If the item is not on the screen, touch ▲/▼ to change the page.

## How to set

🏠 (HOME MENU) → page 77

The default settings are marked with ▶.

### TV TYPE

See page 45.

### DISP OUTPUT

#### ▶ LCD PANEL

Shows displays such as the time code on the LCD screen and in the viewfinder.

#### V-OUT/PANEL

Shows displays such as the time code on the TV screen, LCD screen, and in the viewfinder.

# CLOCK/ LANG

(Items to set clock and language)



Touch ①, then ②.

If the item is not on the screen, touch ▲/▼ to change the page.

## How to set

🏠 (HOME MENU) → page 77

### CLOCK SET

See page 23.

### AREA SET

You can adjust a time difference without stopping the clock.

Set your local area using ▲/▼ when using your camcorder in other time zones. Refer to the world time difference on page 113.

### SUMMERTIME

You can change this setting without stopping the clock.

Set this to [ON] to move the time forward 1 hour.

### LANGUAGE SET

You can select the language to be used on the LCD screen.

#### 💡 Tips

- Your camcorder offers [ENG[SIMP]] (simplified English) for when you cannot find your native tongue among the options.

# GENERAL SET

(Other setup items)

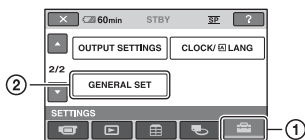

Touch ①, then ②.

If the item is not on the screen, touch ▲/▼ to change the page.

## How to set

🏠 (HOME MENU) → page 77

The default settings are marked with ▶.

## DEMO MODE



If you connect the camcorder to a wall outlet (wall socket), you can view the demonstration in about 10 minutes after you turn the POWER switch to (Movie). The default setting is [ON].

## 💡 Tips

- The demonstration will be suspended in the following situations.
  - When you press START/STOP.
  - When you press DUBBING (DCR-DVD450E/DVD850E)
  - When you touch the screen during the demonstration (The demonstration starts again after about 10 minutes).
  - When you slide the disc cover OPEN switch.
  - When you move the POWER switch to still image recording.
  - When you press 🏠 (HOME)/▶ (VIEW IMAGES).

## CALIBRATION



See page 120.

## A.SHUT OFF (Auto shut off)



### ▶ 5min

The camcorder is automatically turned off when you do not operate your camcorder for more than approximately 5 minutes.

### NEVER

The camcorder is not automatically turned off.

## 🔔 Notes

- When you connect your camcorder to a wall outlet (wall socket), [A.SHUT OFF] is automatically set to [NEVER].

## SUB-T DATE



You can display the recording date and time when playing back a disc on a device with a subtitle display function. The default setting is [ON].

Also refer to the instruction manual of the playback device.

# Activating functions using the OPTION MENU

The OPTION MENU appears just like the pop-up window that appears when you right-click the mouse on a computer. Various functions are displayed.

## Using the OPTION MENU

- 1 While using your camcorder, touch  (OPTION) on the screen.**

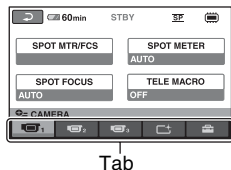
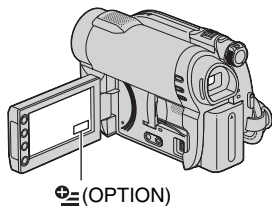

- 2 Touch the desired item.**





If you cannot find the desired item, touch another tab to change the page.

- 3 Change the setting, then touch .**

### Notes







- The tabs and items that appear on the screen depend on the recording/playback status of your camcorder at the time.
- Some items appear without a tab.
- The OPTION MENU cannot be used during Easy Handycam operation (p. 32).

## Recording items on the OPTION MENU

Items	 *	Page
 tab		
SPOT MTR/FCS	-	88
SPOT METER	-	88
SPOT FOCUS	-	88
TELE MACRO	-	89
EXPOSURE	-	89
FOCUS	-	89
SCENE SELECTION	-	90
WHITE BAL.	-	91
 tab		
FADER	-	91
 tab		
REC MODE	<input type="radio"/>	79
BLT-IN ZOOM MIC	-	92
MICREF LEVEL	-	92
 IMAGE SIZE	<input type="radio"/>	81
SELF-TIMER	-	92

\* Items that are included also in the HOME MENU

## Viewing items on the OPTION MENU

Items	 *	Page
 tab		
DELETE**	<input type="radio"/>	48
DELETE by date**	<input type="radio"/>	48
DELETE ALL**	<input type="radio"/>	48
 tab		
PROTECT**	<input type="radio"/>	55
PROTECT by date**	<input type="radio"/>	55
DIVIDE	<input type="radio"/>	58
ERASE**	<input type="radio"/>	60
ERASE ALL**	<input type="radio"/>	60
MOVE**	<input type="radio"/>	61
-- (A tab depends on the situation/No tab)		
 ADD**	<input type="radio"/>	59
 ADD by date**	<input type="radio"/>	59
 ADD ALL**	<input type="radio"/>	59
SLIDE SHOW	-	44
VOLUME	<input type="radio"/>	83
DATA CODE	<input type="radio"/>	82
SLIDE SHOW SET	-	44
DVD MENU	-	68

\* Items that are included also in the HOME MENU

\*\* These items are also available in the HOME MENU, but with different item names.

# Functions set in the OPTION MENU

Items you can set only on the OPTION MENU will be described below.



The default settings are marked with ►.

## SPOT MTR/FCS

You can adjust the exposure and focus for the selected subject simultaneously. This function enables you to use [SPOT METER] (p. 88) and [SPOT FOCUS] (p. 88) at the same time.



① Touch the subject where you want to adjust the exposure and focus on the screen.

 and  appear.

② Touch [END].

To adjust the exposure and focus automatically, touch [AUTO] → [END] in step ①.

### Notes

- If you set [SPOT MTR/FCS], [EXPOSURE] and [FOCUS] are automatically set to [MANUAL].

## SPOT METER (Flexible spot meter)

You can adjust and fix the exposure to the subject, so that it is recorded in suitable brightness even when there is strong contrast between the subject and the background, such as subjects in the spotlight on stage.

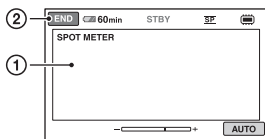

① Touch the point where you want to fix and adjust the exposure on the screen.

 appears.

② Touch [END].

To return the setting to automatic exposure, touch [AUTO] → [END] in step ①.

### Notes

- If you set [SPOT METER], [EXPOSURE] is automatically set to [MANUAL].

## SPOT FOCUS

You can select and adjust the focal point to aim it at a subject not located at the center of the screen.

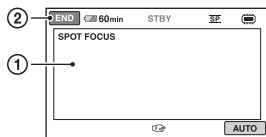

① Touch the subject on the screen.

 appears.

② Touch [END].

To adjust the focus automatically, touch [AUTO] → [END] in step ①.

### Notes

- If you set [SPOT FOCUS], [FOCUS] is automatically set to [MANUAL].

## TELE MACRO



This is useful to record small subjects, such as flowers or insects. You can blur out backgrounds and the subject stands out clearer.

When you set [TELE MACRO] to [ON] (T), the zoom (p. 38) moves to the top of the T (telephoto) side automatically and allows recording subjects at a close distance down to about 50 cm (19 3/4 in.).



To cancel, touch [OFF], or zoom to wide angle (W side).

### Notes

- When recording a distant subject, focusing may be difficult and can take some time.
- Adjust the focus manually ([FOCUS], p. 89) when it is hard to focus automatically.

## EXPOSURE



You can fix the brightness of an image manually. Adjust the brightness when the subject is too bright or too dark relative to the background.

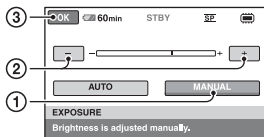

- 1 Touch [MANUAL].  
— appears.
- 2 Adjust the exposure by touching [—]/[+].
- 3 Touch [OK].

To return the setting to automatic exposure, touch [AUTO] → [OK] in step ①.

## FOCUS



You can adjust the focus manually. You can select this function also when you want to focus on a certain subject intentionally.



- 1 Touch [MANUAL].  
E appears.
- 2 Touch [—] (focusing on close subjects)/[+] (focusing on distant subjects) to sharpen the focus. M appears when the focus cannot be adjusted any closer, and A appears when the focus cannot be adjusted farther away.
- 3 Touch [OK].

To adjust the focus automatically, touch [AUTO] → [OK] in step ①.

### Notes

- The minimum possible distance between the camcorder and the subject while maintaining sharp focus is about 1 cm (about 13/32 in.) for wide angle and about 150 cm (about 59 1/8 in.) for telephoto.

### Tips

- It is easier to focus on the subject by moving the power zoom lever towards T (telephoto) to adjust the focus, then towards W (wide angle) to adjust the zoom for recording. When you want to record a subject at close range, move the power zoom lever to W (wide angle), then adjust the focus.
- The focal distance information (the distance at which the subject is focused on, for when it is dark and hard to adjust focus) appears for a few seconds in the following cases. (It will not be displayed correctly if you are using a conversion lens (sold separately).)
  - When the focus mode is switched from automatic to manual.
  - When you set focus manually.

## SCENE SELECTION

You can record images effectively in various situations with the [SCENE SELECTION] function.

### ► AUTO

Select this to automatically record images effectively without the [SCENE SELECTION] function.

### TWILIGHT\* (☾)

Select this to take night view without losing the mood.



### CANDLE (🕯)

Select this to take scene without losing candle mood.



### SUNRISE&SUNSET\* (☀)

Select this to reproduce the atmosphere of scenes such as sunsets or sunrises.



### FIREWORKS\* (💣)

Select this to take spectacular shots of fireworks.



### LANDSCAPE\* (🏞)

Select this to record distant subjects clearly. This setting also prevents your camcorder from focusing on glass or metal mesh in windows that comes in between the camcorder and the subject.



### PORTRAIT (👤)

Select this to bring out the subject such as people or flowers while creating a soft background.



### SPOTLIGHT\*\* (🎤)

Select this to prevent people's faces from appearing excessively white when subjects are lit by strong light.



### SPORTS\*\* (Sports lesson) (🏃)

Select this to minimize shake when recording fast moving subjects.



### BEACH\*\* (🏖)

Select this to take the vivid blue of the ocean or a lake.



### SNOW\*\* (❄)

Select this to take bright pictures of a white landscape.



\* Your camcorder is set to focus only on distant subjects.

\*\* Your camcorder is set not to focus on nearby subjects.

### Notes

- The [WHITE BAL.] setting is cleared when you set [SCENE SELECTION].

## WHITE BAL. (White balance)



You can adjust the color balance to the brightness of the recording environment.

### ► AUTO

The white balance is adjusted automatically.

### OUTDOOR (☀)

The white balance is adjusted to be appropriate for the following recording conditions:

- Outdoors
- Night views, neon signs and fireworks
- Sunrise or sunset
- Under daylight fluorescent lamps

### INDOOR (☹)

The white balance is adjusted to be appropriate for the following recording conditions:

- Indoors
- At party scenes or studios where the lighting conditions change quickly
- Under video lamps in a studio, or under sodium lamps or incandescent-like color lamps

### ONE PUSH (📷)

The white balance will be adjusted according to the ambient light.

- ① Touch [ONE PUSH].
- ② Frame a white object such as a piece of paper, to fill the screen under the same lighting conditions as you will record the subject.
- ③ Touch [📷].  
📷 flashes quickly. When the white balance is adjusted and stored in the memory, the indicator stops flashing.

### 🔔 Notes

- Set [WHITE BAL.] to [AUTO] or adjust the color in [ONE PUSH] under white or cool white fluorescent lamps.
- When you select [ONE PUSH], keep framing white object while 📷 is flashing quickly.

- 📷 flashes slowly if [ONE PUSH] could not be set.
- When [ONE PUSH] was selected, if 📷 keeps flashing after touching [OK], set [WHITE BAL.] to [AUTO].
- If you set [WHITE BAL.], [SCENE SELECTION] is automatically set to [AUTO].

### 💡 Tips

- If you changed the battery pack, or moved your camcorder to or from outdoors when [AUTO] was selected, aim your camcorder at a nearby white object with [AUTO] for about 10 seconds for better color balance adjustment.
- If you changed the [SCENE SELECTION] setting or moved your camcorder to or from outdoors during white balance setting with [ONE PUSH], you need to repeat the [ONE PUSH] operation.

## FADER



You can record a transition with the following effects adding to the interval between scenes.

- ① Select the desired effect in [STBY] (during fading in) or [REC] (during fading out) mode, then touch [OK].
- ② Press START/STOP.

The fader indicator stops flashing and disappears when the fade is complete.

To cancel the fader before starting the operation, touch [OFF] in step ①. If you press START/STOP, the setting is cleared.



### WHITE FADER



### BLACK FADER



### BLT-IN ZOOM MIC



When you set [BLT-IN ZOOM MIC] to [ON] (  ), you can record sound with directivity as you move the power zoom lever. The default setting is [OFF].

### MICREF LEVEL



You can select the microphone level for recording sound.  
Select [LOW] when you want to record exciting and powerful sound in a concert hall, etc.

#### ► NORMAL

Records various surround sounds, converting them into the certain level.

#### LOW ( ↓ )

Records surround sound faithfully. This setting is not suitable for recording conversations.

### SELF-TIMER



When you set [SELF-TIMER] to [ON],  appears on the screen.

When you press PHOTO, your camcorder starts counting down, and records a still image after about 10 seconds.

To cancel recording, touch [RESET].

To cancel the self-timer, select [OFF].

# What you can do with Windows computer

When you install the “PMB” (Picture Motion Browser) on a Windows computer from the supplied CD-ROM, you can enjoy the following operations.

- **Importing images taken with your camcorder to a computer**
- **Viewing imported images on a computer**
- **Creating a DVD**
- **Copying a disc**  
→ Video Disc Copier

For details on the functions of “PMB,” see “PMB Guide” (p. 97).

## ■ Using a Macintosh computer

The supplied software “PMB” does not support a Macintosh computer. On the advanced use of images on your camcorder connected to your Macintosh computer, see the following URL:  
<http://guide.d-imaging.sony.co.jp/mac/ms/us/>

## System Requirements

### ■ Environment for using “PMB”

**OS:** Microsoft Windows XP SP3\*/ Windows Vista SP1\*\*

\* 64-bit editions and Starter (Edition) are not supported.

\*\* Starter is not supported.

• Standard installation is required.

• Operation is not assured if the above OS has been upgraded or in a multi-boot environment.

**CPU:** Intel Pentium III 1 GHz CPU or faster

**Application:** DirectX 9.0c or later (This product is based on DirectX technology. It is necessary to have DirectX installed.)

**Memory:** 256 MB or more

**Hard disk:** Disk volume required for installation: Approximately 500 MB (5 GB or more may be necessary when creating a DVD.)

**Display:** Minimum 1,024 × 768 dots

**Others:** ψ USB port (this must be provided as standard), Hi-Speed USB (USB 2.0 compatible), DVD burner (CD-ROM drive is necessary for installation.)

### 🔗 Notes

- Your computer must meet hardware requirements other than those described above for each OS.
- Even in a computer environment where the operations are guaranteed, frames may be dropped from movies, resulting in uneven playback. However, imported images and images on discs created subsequently will not be affected.
- Operations are not guaranteed on all the recommended environments. For example, other open or background applications running on currently may limit product performance.
- “PMB” does not support 5.1ch surround sound reproduction. The sound is reproduced in 2ch sound.
- Depending on your computer, 8 cm media (DVD+R DL, etc.) cannot be used.

## What you can do with Windows computer (Continued)

- If you use a Notebook PC, connect it to the AC Adaptor as the power source. Otherwise, the software will not work properly due to the power saving function of the PC.
- You can read images recorded on “Memory Stick PRO Duo” media in a “Memory Stick” media slot of a computer. However, in the following cases, do not use the “Memory Stick” media slot of the computer, but connect your camcorder to the computer with the USB cable:
  - The computer is not compatible with “Memory Stick PRO Duo” media.
  - A “Memory Stick Duo” media adaptor is required.
  - “Memory Stick PRO Duo” media cannot be read in the “Memory Stick” media slot.
  - Reading data from the “Memory Stick” media slot is slow.

### Installing software

You need to install the software to your Windows computer **before connecting your camcorder to the computer**. The installation is required only for the first time.

Contents to be installed and procedures may differ depending on your OS.

#### Notes

- If a version of “PMB” has already been installed on the computer, check the version. To display it, click [Help] → [About PMB] in the menu bar of “PMB.” Compare the version with that of the “PMB” on the supplied CD-ROM to make sure that the higher version will be installed over the lower version. If the version of the previously installed “PMB” is higher, uninstall it first, and install both versions in ascending version order. Otherwise, some functions of “PMB” may not work properly.

---

**1 Confirm that your camcorder is not connected to the computer.**

---

**2 Turn on the computer.**

#### Notes

- Log on as an Administrator for installation.
- Close all applications running on the computer before installing the software.

---

**3 Place the supplied CD-ROM in the disc drive of your computer.**

The installation screen appears.



**If the screen does not appear**

- ① Click [Start] → [Computer] (in Windows XP, [My Computer]).
- ② Double-click [SONYPICUTIL (E:)] (CD-ROM) (disc drive).\*

\* Drive names (such as (E:)) may vary depending on the computer.

---

**4 Click [Install].**

---

**5 Select the language for the application to be installed, then click [Next].**

---

**6 As the screen to confirm the connection appears, connect your camcorder to the computer following the steps below.**

- ① Connect the AC Adaptor to a wall outlet (wall socket).
- ② Turn on your camcorder.
- ③ Connect the  $\psi$  (USB) jack (p. 126) of your camcorder to the computer using the supplied USB cable.

- ④ Touch [ USB CONNECT] on the screen of your camcorder.

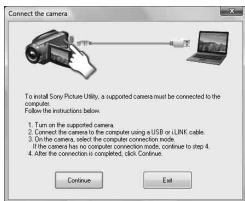

- 7 Click [Continue].

- 8 Read the terms of the license agreement carefully. If you agree to the terms, change  to , then click [Next].

- 9 Confirm the installation settings, then click [Install].

 Notes

- Even if a screen prompting you to restart your computer appears, you do not need to restart it at this time. Restart your computer after completing the installation.
- It may take some time for the authentication.

- 10 Follow the on-screen instructions to install the software.

One of the following installation screens appears, depending on the computer environment. Check the screen and follow the instructions displayed to install the required software.

- Sonic UDF Reader\*  
Software required to recognize a DVD-RW (VR mode) disc
- Microsoft DirectX 9.0c\*  
Software required to handle movies

\* Windows XP only

- 11 Restart the computer if required to complete the installation.



- 12 Remove the CD-ROM from the disc drive of your computer.

## Importing movies on a disc to a computer

You can copy the desired movies on a disc from your camcorder to a computer.

 Notes

- Connect your camcorder to the wall outlet (wall socket) using the supplied AC Adaptor for this operation (p. 21).

- 1 Turn on your camcorder.

- 2 Connect the  (USB) jack of your camcorder to a computer using the supplied USB cable.

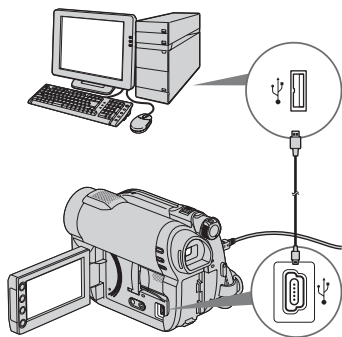

The [USB SELECT] screen appears on the camcorder screen.

---

### 3 Touch [🖱️ USB CONNECT].

The window for selecting movies to be imported is displayed.



---

### 4 On the computer screen, select the movies you want to import from the disc.

Put a check  in the checkbox of the movies you want to import.

To import all the movies, click [Select All].

---

### 5 Click [Next].

The window for setting a folder to import the movies to is displayed.

You can change the folder.

---

### 6 Click [Import].

Importing of the selected movies starts.

When importing is completed, “PMB” starts up automatically on the computer, and the imported movies are displayed in the window.

### Importing entire movies and still images to a computer (Easy PC Back-up)

Movies and still images recorded on the internal memory (DCR-DVD450E/DVD850E) or recorded on “Memory Stick PRO Duo” media that have not yet been imported to a computer by Easy PC Back-up function can be imported to your computer automatically.

#### 🔌 Notes

- You cannot save movies that are recorded on a disc using this function.
- Connect your camcorder to the wall outlet (wall socket) using the supplied AC Adaptor for this operation (p. 21).

---

### 1 Follow step 1 to 2 in “Importing movies on a disc to a computer.”

---

### 2 Select [🖱️ USB CONNECT] (DCR-DVD450E/DVD850E) or [🖱️ USB CONNECT] on the LCD screen of your camcorder.

The [Handycam Utility] window is displayed on the screen of the computer.



---

### 3 Click [Easy PC Back-up] in the [Handycam Utility] window.

---

### 4 Select the file format to be imported, and click [Import].

Movies and still images that have not been imported to a computer are automatically imported to your computer.

When the import of the data is completed, “PMB” starts up automatically and the imported movies and still images are displayed in the window.

#### Tips

- To import selected images, select [Media File Import] in step 3. Refer to “PMB Guide” for details on the operation (p. 97).

## Starting “PMB” (Picture Motion Browser)

Double-click the “PMB” short-cut icon on the computer screen.



- If the icon is not displayed on the computer screen, click [Start] - [All Programs] - [Sony Picture Utility] - [PMB] to start “PMB.”

You can view, edit, or create discs of movies and still images using “PMB.”

## Referring to “PMB Guide”

Double-click the “PMB Guide” short-cut icon on the computer screen to open “PMB Guide.”



- If the icon is not displayed on the computer screen, click [Start] - [All Programs] - [Sony Picture Utility] - [Help] - [PMB Guide]. You can also open “PMB Guide” from [Help] of “PMB.”

## Creating discs

You can create a disc by putting together movies and still images previously imported to your computer (p. 95).

---

### 1 Turn on your computer, and place an empty disc in the DVD drive.

- See page 12 for the type of discs you can use.
- If any other software starts automatically, shut it down.

---

### 2 Double-click the “PMB” short-cut icon on the computer screen to start “PMB.”

- You can also start “PMB” by clicking [Start] - [All Programs] - [Sony Picture Utility] - [PMB].

---

### 3 Click [Folders] or [Calendar] on the left side of the window, and select the folder or date, then select the movies and still images.

- To select multiple movies and still images, hold the Ctrl key down while selecting.

### 4 At the top of the window, click [Manipulate] - [DVD-Video (SD) Creation].

The window for selecting movies and still images appears.

- To add movies and still images to the previously selected ones, select them in the main window and drag and drop onto the window for selecting movies and still images.

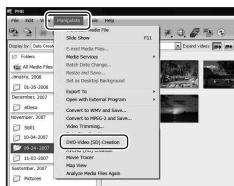

### 5 Follow the instructions on the screen to create the disc.

- It may take a long time to create a disc.

## Other functions

### Copying discs

You can copy a recorded disc to another disc using "Video Disc Copier."

Click [Start] - [All Programs] - [Sony Picture Utility] - [Video Disc Copier] to start the software.

Refer to the "Video Disc Copier" help for details on the operation.

### Editing movies

You can cut out only a necessary part from a movie and save it as another file.

Using "PMB", select the movie you want to edit, then click [Manipulate] - [Video Trimming] to display the Video Trimming window. Refer to "PMB Guide" for details on the operation (p. 97).

### Capturing still images from a movie

You can save a frame of a movie as a still image.

On the movie playback window of "PMB", click  to display the [Save Frame] window.

Refer to "PMB Guide" for details on the operation (p. 97).

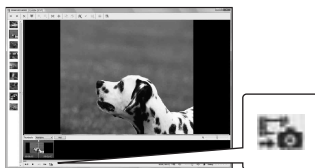

## Recommended USB cable connection

To assure the proper functioning of your camcorder, connect your camcorder to a computer as below.

- Connect only the camcorder to the USB port of your computer. Do not connect anything else to other USB ports of a computer.
- When connecting to a computer with a USB keyboard and USB mouse connected as standard equipment, connect the camcorder to another USB port using the USB cable.

### ⚠ Notes

- Operations are not guaranteed when multiple USB devices are connected to a computer.
- Be sure to connect the USB cable to a USB port. If the USB cable is connected to a computer via a USB keyboard or USB hub, operations are not guaranteed.

## To disconnect the USB cable

- 1 Click the  icon on the task tray on the bottom right of the desk top.



- 2 Click [Safely remove USB Mass Storage Device].



- 3 Touch [END] on the screen of your camcorder.

- 4 Touch [YES] on the screen of your camcorder.

- 5 Disconnect the USB cable from the camcorder and the computer.

### Notes

- Do not disconnect the USB cable while the ACCESS/access lamp is lit.
- Before turning off your camcorder, disconnect the USB cable following the proper procedures described above.
- Disconnect the USB cable using the proper procedures described above. Otherwise, files stored on the media may not be updated correctly. Also, disconnecting the USB cable improperly may cause a malfunction of the media.

# Troubleshooting

If you run into any problems using your camcorder, use the following table to troubleshoot the problem. If the problem persists, disconnect the power source and contact your Sony dealer.

• Overall operations/Easy Handycam operation .....	100
• Batteries/Power sources .....	101
• LCD screen/Viewfinder.....	102
• Media .....	102
• Recording .....	103
• Playing back images on your camcorder ....	104
• Playing back a disc on other devices.....	105
• Playing back "Memory Stick PRO Duo" media on other devices.....	106
• Editing images on your camcorder .....	106
• Connecting/Dubbing to other devices .....	107
• Connecting to a computer.....	107
• Functions that cannot be used simultaneously .....	107

## Overall operations/Easy Handycam operation

### The power does not turn on.

- Attach a charged battery pack to the camcorder (p. 20).
- Connect the plug of the AC Adaptor to the wall outlet (wall socket) (p. 20).

### The camcorder does not operate even when the power is set to on.

- It takes a few seconds for your camcorder to be ready to record after the power is turned on. This is not a malfunction.
- Disconnect the AC Adaptor from the wall outlet (wall socket) or remove the battery pack, then reconnect it after about 1 minute. If the functions still do not work, press the RESET button (p. 126) using a sharp-pointed object. (If you press the RESET button, all settings, including the clock setting, are reset.)
- The temperature of your camcorder is extremely high. Turn off your camcorder and leave it for a while in a cool place.

### Buttons do not work.

- During Easy Handycam operation (p. 32), the following buttons/functions are not available.
  -  (Backlight) button (p. 39)
  - Playback zoom (p. 43)
  - DUBBING button (DCR-DVD450E/DVD850E) (p. 52)

### The (OPTION) button is not displayed.

- The OPTION MENU cannot be used during Easy Handycam operation (p. 32).

### The menu settings have been changed automatically.

- Most menu items automatically return to their default settings during Easy Handycam operation (p. 32).
- The following menu items are fixed during Easy Handycam operation:
  - Movie recording mode: [SP]
  - [DATA CODE]: [DATE/TIME]
  - Recording format for DVD-RW: [VIDEO]
- The following function/menu items return to the default settings if the POWER switch is set to OFF (CHG) for more than 12 hours:
  - Backlight
  - [DVD MENU]
  - [SPOT MTR/FCS]
  - [SPOT METER]
  - [SPOT FOCUS]
  - [EXPOSURE]
  - [FOCUS]
  - [SCENE SELECTION]
  - [WHITE BAL.]
  - [BLT-IN ZOOM MIC]
  - [MICREF LEVEL]

---

**Even if you press EASY, menu settings do not switch to their defaults automatically.**

- Following menu settings remain as they were set even during Easy Handycam operation (p. 32).
  - [MOVIE MEDIA SET]
  - [PHOTO MEDIA SET]\*
  - [AUDIO MODE]\*
  - [WIDE SELECT]
  - [SUB-T DATE]
  - [FACE SET]
  - [IMAGE SIZE]
  - [FILE NO.]
  - [VOLUME]
  - [BEEP]
  - [TV TYPE]
  - [CLOCK SET]
  - [AREA SET]
  - [SUMMERTIME]
  - [LANGUAGE SET]
  - [DEMO MODE]
- \* DCR-DVD450E/DVD850E

---

**Your camcorder vibrates.**

- Vibration occurs depending on the condition of the disc. This is not a malfunction.

---

**A vibration is felt in your hand or a faint sound is heard during operation.**

- This is not a malfunction.

---

**A motor sound is heard in the camcorder when the disc cover is closed without a disc.**

- Your camcorder is trying to recognize the disc. This is not a malfunction.

---

**Your camcorder gets warm.**

- This is because the power has been turned on for a long time. This is not a malfunction. Turn off your camcorder and leave it for a while in a cool place.

## Batteries/Power sources

### The power abruptly turns off.

- When approximately 5 minutes have elapsed while you do not operate your camcorder, the camcorder is automatically turned off (A.SHUT OFF). Change the setting of [A.SHUT OFF] (p. 85), or turn on the power again, or use the AC Adaptor.
- Charge the battery pack (p. 20).

---

### The CHG (charge) lamp does not light while the battery pack is being charged.

- Turn the POWER switch to OFF (CHG) (p. 20).
- Attach the battery pack to the camcorder correctly (p. 20).
- Connect the power cord (mains lead) to the wall outlet (wall socket) properly.
- The battery charge is completed (p. 20).

---

### The CHG (charge) lamp flashes while the battery pack is being charged.

- Attach the battery pack to the camcorder correctly (p. 20). If the problem persists, disconnect the AC Adaptor from the wall outlet (wall socket) and contact your Sony dealer. The battery pack may be damaged.

---

### The remaining battery time indicator does not indicate the correct time.

- The ambient temperature is too high or too low. This is not a malfunction.
- The battery pack has not been charged enough. Fully charge the battery pack again. If the problem persists, replace the battery pack with a new one (p. 20).
- The indicated time may not be correct depending on the environment of use.

---

### The battery pack is quickly discharged.

- The ambient temperature is too high or low. This is not a malfunction.
- The battery pack has not been charged enough. Fully charge the battery pack again. If the problem persists, replace the battery pack with a new one (p. 20).

### LCD screen/Viewfinder

#### Menu items are grayed out.

- You cannot select grayed items in the current recording/playback situation.
- There are some functions you cannot activate simultaneously (p. 107).

---

#### The buttons do not appear on the touch panel.

- Touch the LCD screen lightly.
- Press DISP on your camcorder (p. 25).

---

#### The buttons on the touch panel do not work correctly or do not work at all.

- Adjust the touch panel ([CALIBRATION], p. 120).

---

#### The image in the viewfinder is not clear.

- Pull out the viewfinder, then move the viewfinder lens adjustment lever until the image appears clearly (p. 25).

---

#### The image in the viewfinder has disappeared.

- Close the LCD panel. No image is displayed in the viewfinder when the LCD panel is open (p. 25).

### Media

#### The disc cannot be removed.

- Make sure the power source (battery pack or AC Adaptor) is connected correctly (p. 20).
- The disc is damaged or is dirty with fingerprints, etc. In this case, it may take up to 10 minutes to remove the disc.
- The temperature of your camcorder is extremely high. Turn off your camcorder and leave it for a while in a cool place.
- You turned off your camcorder during finalizing the disc. Turn on your camcorder and complete finalizing the disc (p. 66).

---

#### Images recorded on a disc cannot be deleted.

- The maximum number of images that you can delete on the INDEX screen at one time is 100.
- You cannot delete following movies (p. 48).
  - Movies recorded on DVD-R/DVD+R DL
  - Movies recorded on DVD-RW (VIDEO mode) except the last recorded movie
  - Movies recorded on DVD+RW except the last recorded movie

---

#### The indicators of the disc type and the recording format on the LCD screen are grayed out.

- The disc may have been created on another device. You can play back the disc with your camcorder, but you cannot record additional movies on the disc.
- You inserted a disc that cannot be used with your camcorder.
- Your camcorder could not recognize the disc.

---

#### You cannot operate functions using the “Memory Stick PRO Duo” media.

- If you use “Memory Stick PRO Duo” media formatted on a computer, format it again on your camcorder (p. 71).

---

**You cannot delete images on the “Memory Stick PRO Duo” media.**

- The maximum number of images that you can delete on the INDEX screen at one time is 100.
- You cannot delete protected images (p. 55).

---

**The data file name is not indicated correctly or flashes.**

- The file is corrupted.
- The file format is not supported by your camcorder. Use the supported file format (p. 116).

## Recording

Refer also to “Media” (p. 102).

---

**Pressing START/STOP or PHOTO does not record images.**

- The playback screen is displayed. Set your camcorder to recording standby (p. 37).
- Your camcorder is recording the image you have just shot on the media.
- The media has run out of space. Format the media (internal memory (DCR-DVD450E/DVD850E)/DVD-RW/DVD+RW/“Memory Stick PRO Duo” media) (p. 71). Delete unnecessary images (p. 48), or use a new disc or “Memory Stick PRO Duo” media.
- When you are using one of the following discs after finalizing it, make the disc to be able to record additional movies (p. 73). Or use a new disc.
  - DVD-RW (VIDEO mode)
  - DVD+RW
- The temperature of your camcorder is extremely high. Turn off your camcorder and leave it for a while in a cool place.
- Moisture condensation has occurred. Turn off your camcorder and leave it for about 1 hour (p. 119).
- The number of still images exceeds the capacity of your camcorder (p. 81, 81). Delete unnecessary images (p. 48).

---

**You cannot record a still image.**

- You cannot record a still image on a disc on your camcorder.

---

**The ACCESS/access lamp lights up even when you stop recording.**

- Your camcorder is recording the image you have just record on the media.

---

**The imaging field looks different.**

- The imaging field may look different depending on the condition of your camcorder. This is not a malfunction.

---

**The actual recording time for movie is less than the expected recording time of the media.**

- Depending on the conditions when recording a fast moving object or so, the time available for recording may shorten.

---

**The recording stops.**

- The temperature of your camcorder is extremely high. Turn off your camcorder and leave it for a while in a cool place.
- Moisture condensation has occurred. Turn off your camcorder and leave it about 1 hour (p. 119).

---

**There is a time difference between the point where you press START/STOP and the point that movie recording starts/stops.**

- On your camcorder, there may be a slight time difference between the point where you press START/STOP and the actual point that movie recording starts/stops. This is not a malfunction.



### The movie aspect ratio (16:9/4:3) cannot be changed.

- You cannot change the movie aspect ratio in the following cases.
    - When [DISC] is selected on [MOVIE MEDIA SET], you inserted a DVD+RW, or no disc is inserted.
    - When [MEMORY STICK] is selected on [MOVIE MEDIA SET], no “Memory Stick PRO Duo” media is inserted.
- 

### The auto focus does not function.

- Set [FOCUS] to [AUTO] (p. 89).
  - The recording conditions are not suitable for auto focus. Adjust the focus manually (p. 89).
- 

### [ STEADYSHOT] does not function.

- Set [ STEADYSHOT] to [ON] (p. 80).
  - [ STEADYSHOT] may not be able to compensate for excessive vibrations.
- 

### Undesirable flicker occurs.

- This occurs when recording images under a fluorescent lamp, sodium lamp, or mercury lamp. This is not a malfunction.
- 

### A vertical band appears when recording candlelight or electric light in the dark.

- This occurs when the contrast between the subject and the background is too high. This is not a malfunction.
- 

### A vertical white line appears on an image taken in bright light.

- This phenomenon is called the smear effect. This is not a malfunction.
- 

### Black bands appear when you record a TV screen or computer screen.



- Set [ STEADYSHOT] to [OFF] (p. 80).
- 

### You cannot adjust [LCD BL LEVEL].

- You cannot adjust [LCD BL LEVEL] when:
    - The LCD panel is closed on your camcorder with the LCD screen facing out.
    - The power is supplied from the AC Adaptor.
- 

### Playing back images on your camcorder

#### You cannot find the images to be played back.

- Select the media to be played back by touching  (HOME) →  (MANAGE MEDIA) → [MOVIE MEDIA SET] or [PHOTO MEDIA SET] (p. 26).
- 

#### You cannot play back a disc.

- Check out the disc compatibility (p. 12).
  - Insert a disc with the recording side facing your camcorder (p. 28).
  - The disc that was recorded, formatted, or finalized on other devices may not be played back on your camcorder.
  - The temperature of your camcorder is extremely high. Turn off your camcorder and leave it for a while in a cool place.
- 

#### The playback image is distorted.

- Clean the disc using a soft cloth (p. 116).
- 

#### Images stored on “Memory Stick PRO Duo” media cannot be played back.

- Images cannot be played back if you have modified files or folders, or have edited the data on a computer. (The file name flashes when viewing the still image.) This is not a malfunction (p. 117).
  - Images recorded on other devices may neither be played back, nor displayed in actual size. This is not a malfunction (p. 117).
-

---

**“?” is indicated on an image in the VISUAL INDEX screen.**

- Loading of the data may have failed. It may be indicated correctly when you turn off the power and then turn it on again, or repeat removing and inserting the “Memory Stick PRO Duo” media a couple of times.
- You removed the battery pack or the AC Adaptor while the access lamp is flashing. This operation may damage the image data, which will be marked with “?”.
- This may appear on still images recorded on other devices, edited on a computer, etc.

---

**“” is indicated on an image in the VISUAL INDEX screen.**

- Perform [REPAIR IMG.DB F.] (p. 75). If it still appears, delete the image marked with “” (p. 48).

---

**No sound or only a quiet sound is heard during playback.**

- Turn up the volume (p. 34, 42).
- Sound is not output when the LCD screen is closed. Open the LCD screen.
- When you record sound with [MICREF LEVEL] set to [LOW] (p. 92), the recorded sound may be difficult to hear.

**Playing back a disc on other devices**

**You cannot play back the disc, or the disc is not recognized.**

- Clean the disc using a soft cloth (p. 116).
- Finalize the disc (p. 66).
- A disc recorded in VR mode cannot be played back on a device that does not support VR mode. Check the compatibility in the instruction manual of the playback device.

---

**The playback image is distorted.**

- Clean the disc using a soft cloth (p. 116).

---

**“?” is indicated on an image in the DVD menu.**

- Loading of the data may have failed while finalizing the disc. For the following discs, make the disc capable of additional recording (p. 73), then remake the DVD menu by finalizing the disc again (p. 66). The DVD menu may be displayed correctly.
  - DVD-RW (VIDEO mode)
  - DVD+RW

---

**Playback freezes for an instant between the scenes.**

- The image may freeze for an instant between scenes depending on the device being used. This is not a malfunction.
- In the case of a DVD+R DL, the image may freeze for an instant when the recording layer changes. This is not a malfunction.

---

**Playback does not move to the previous scene when you press ◀◀.**

- If playback crosses 2 titles made automatically by your camcorder when ◀◀ is pressed, playback may not move to the previous scene. Select the desired scene from the menu screen. Refer to the instruction manual of the playback device for further information.

---

**When you play the disc on a computer or another playback device, the left and right sounds are heard out of balance (DCR-DVD450E/DVD850E).**

- This may happen when sound recorded with 5.1ch surround is converted to 2ch (normal stereo sound) on a computer or another playback device (p. 38). This is not a malfunction.
- If the playback device is a 2ch stereo system, change the audio conversion system (downmix system). For details, refer to the instruction manuals of the playback device.

## Troubleshooting (Continued)

- When you create a disc using the supplied “PMB” software, select 2ch for the audio setting.
- Record movies with [AUDIO MODE] set to [2ch STEREO] on your camcorder (p. 79).

---

### The movie is not played in the correct aspect ratio.

- If movies in both 16:9 (wide) and 4:3 are dubbed on a DVD+RW, those movies may not be played in the correct aspect ratio depending on the playback device. This is not a malfunction.



### Playing back “Memory Stick PRO Duo” media on other devices

#### You cannot play back the “Memory Stick PRO Duo” media, or the “Memory Stick PRO Duo” media is not recognized.

- The device may not support “Memory Stick PRO Duo” media.

### Editing images on your camcorder

#### Unable to edit.

- Select a media to be edited by touching  (HOME) →  (MANAGE MEDIA) → [MOVIE MEDIA SET] or [PHOTO MEDIA SET] (p. 26).
- You cannot edit movies recorded on DVD-R/DVD+R DL (p. 12).
- There are no images recorded.
- Unable to edit because of the condition of the image.
- You cannot edit protected images (p. 55).
- You cannot dub movies from a disc to the internal memory (DCR-DVD450E/DVD850E) or “Memory Stick PRO Duo” media.

---

### Movies cannot be added in the Playlist.

- The media is full.
- To a Playlist, you can add 99 movies on the internal memory (DCR-DVD450E/DVD850E) or “Memory Stick PRO Duo” media, or 999 movies on a disc (p. 59). Delete unnecessary images (p. 48).
- You cannot add still images in the Playlist.

---

### Movies cannot be divided.

- A movie that is too short cannot be divided.
- A movie that is protected cannot be divided (p. 55).

---

### Images cannot be deleted.

- You cannot delete following movies (p. 48).
  - Movies recorded on DVD-R/DVD+R DL
  - Movies recorded on DVD-RW (VIDEO mode) except the last recorded movie
  - Movies recorded on DVD+RW except the last recorded movie
- In the case of disc, you cannot delete movies during Easy Handycam operation (p. 32).
- Images that are protected cannot be deleted (p. 55).

---

### Unable to capture a still image from a movie.

- There is not enough free space on the media for saving still images (DCR-DVD450E/DVD650E/DVD850E) (p. 50).

---

### Unable to finalize.

- Use the AC Adaptor for finalizing operation. Do not use the battery pack.
- The disc has already been finalized. In the case of following discs, follow the required procedure to record additional movies (p. 73):
  - DVD-RW (VIDEO mode)
  - DVD+RW

---

### Unable to [UNFINALIZE].

- [UNFINALIZE] is not available for the following discs:
  - DVD-RW (VR mode)
  - DVD+RW

- DVD-R
- DVD+R DL

- [UNFINALIZE] is not available during Easy Handycam operation (p. 32).

---

### You cannot edit or record additional images on a disc using other devices.

- You may not be able to edit or record additional images on a disc recorded on your camcorder using other devices.

### Connecting/Dubbing to other devices

#### You cannot hear the sound on the TV connected to your camcorder.

- This is because only the S VIDEO plug is connected. Make sure that you connect also the red and white plugs of the A/V connecting cable with S VIDEO (sold separately) (p. 62).

#### The aspect ratio of the image is not correct on the 4:3 TV connected to your camcorder.

- Set [TV TYPE] depending on your TV (p. 45).

#### You cannot dub.

- The A/V connecting cable is not connected properly. Make sure that the A/V connecting cable is connected to the proper jack, i.e. to the input jack of another device for dubbing a movie from your camcorder (p. 52).

### Connecting to a computer

#### You cannot install "PMB."

- Check the computer environment required to install "PMB."
- Install "PMB" in an orderly manner (p. 94).

#### "PMB" does not work correctly.

- Finish "PMB" and restart your computer.

---

### Your camcorder is not recognized by the computer.

- Install "PMB" (p. 94).
- Disconnect devices from the USB jack of the computer other than the keyboard, mouse, and your camcorder.
- Disconnect the USB cable from the computer and your camcorder, and restart the computer, then connect the computer and your camcorder again in an orderly manner (p. 94).
- Make sure the media check tool of the computer activates. For details on the media check tool, see "PMB Guide" (p. 97).

### Functions that cannot be used simultaneously

The following list shows examples of unworkable combinations of functions and menu items.

Cannot use	Because of following settings
Backlight	[SPOT MTR/FCS], [SPOT METER], [FIREWORKS], [MANUAL] in [EXPOSURE]
[AUTO SLW SHUTTR]	[SCENE SELECTION], [FADER]
[SPOT FOCUS]	[SCENE SELECTION]
[TELE MACRO]	[SCENE SELECTION]
[SCENE SELECTION]	[TELE MACRO], [FADER]
[FADER]	[CANDLE]/ [FIREWORKS] in [SCENE SELECTION]
[MICREF LEVEL]	[BLT-IN ZOOM MIC]

# Warning indicators and messages

## Self-diagnosis display/Warning indicators

If indicators appear on the LCD screen or in the viewfinder, check the following. Some symptoms you can fix by yourself. If the problem persists even after you have tried a couple of times, contact your Sony dealer or local authorized Sony service facility.

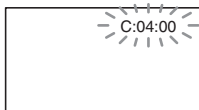

### C: (or E:) □□:□□ (Self-diagnosis display)

#### C:04:□□

- The battery pack is not an “InfoLITHIUM” H series battery pack. Use an “InfoLITHIUM” H series battery pack (p. 117).
- Connect the DC plug of the AC Adaptor to the DC IN jack of your camcorder securely (p. 20).

#### C:13:□□

- The disc is faulty. Use a compatible disc with your camcorder (p. 12).
- The disc is dirty or has scratches on it. Clean the disc with a cleaning cloth (p. 116).

#### C:32:□□

- Symptoms that are not described above have occurred. Remove the disc and insert it again, then operate your camcorder again.
- Remove the power source. Reconnect it again and operate your camcorder again.

E:20:□□ / E:31:□□ / E:61:□□ /  
E:62:□□ / E:91:□□ / E:94:□□

- A malfunction that you cannot service has occurred. Contact your Sony dealer or local authorized Sony service facility. Inform them of the 5-digit code, which starts from “E.”

### 101-0001 (Warning indicator pertaining to files)

#### Slow flashing

- The file is damaged.
- The file is unreadable.

### (Warning indicator pertaining to discs)

#### Slow flashing

- A disc is not inserted.\*
- Less than 5 minutes remains for recording movies.
- A disc that cannot be read or written is inserted, such as the single-sided disc inserted inside out.

#### Fast flashing

- Your camcorder cannot recognize the disc.\*
- A finalized disc is inserted into your camcorder during recording standby.
- The disc is fully recorded.\*
- The disc recorded in the different TV color system from your camcorder is inserted when  (Movie) is selected.\*

### (You need to remove the disc)\*

#### Fast flashing

- Your camcorder cannot recognize the disc.
- The disc is fully recorded.
- An error might have occurred with the disc drive in your camcorder.
- A finalized disc is inserted during recording standby (p. 73).

---

 **(Battery level warning)**

**Slow flashing**

- The battery pack is nearly used up.
- Depending on the operating environment, or battery conditions,  may flash, even if there are approximately 20 minutes remaining.

---

 **(High temperature warning)**

**Slow flashing**

- The temperature of your camcorder is getting higher. Turn off your camcorder and leave it for a while in a cool place.

**Fast flashing\***

- The temperature of your camcorder is extremely high. Turn off your camcorder and leave it for a while in a cool place.

---

 **(Warning indicator pertaining to “Memory Stick PRO Duo” media)**

**Slow flashing**

- There is not enough free space for recording. See page 5 for the type of “Memory Stick PRO Duo” media you can use in your camcorder.
- No “Memory Stick PRO Duo” media is inserted (p. 30).

**Fast flashing\***

- There is no free space for recording. Delete unnecessary images (p. 48), or format the “Memory Stick PRO Duo” media (p. 71) after dubbing/copying images (p. 52, 62, 93).
- The image database file is broken (p. 75).

---

 **(Warning indicators pertaining to “Memory Stick PRO Duo” media formatting)\***

- The “Memory Stick PRO Duo” media is damaged.
- The “Memory Stick PRO Duo” media is not formatted correctly (p. 71, 116).

---

 **(Warning indicator pertaining to incompatible “Memory Stick PRO Duo” media)\***

- Incompatible “Memory Stick PRO Duo” media is inserted (p. 116).

---

 **(Warning indicator pertaining to the write-protect of the “Memory Stick PRO Duo” media)\***

- Access to the “Memory Stick PRO Duo” media was restricted on another device.

---

 **(Warning indicator pertaining to camera-shake warning)**

- The camcorder is unsteady, so camera-shake easily occurs. Hold the camcorder steady with both hands and shoot the image. However, note that the camera-shake warning indicator does not disappear.

---

 **(Warning indicator pertaining to still image recording)**

- There is not enough free space for recording on your media.

---

\* You hear a melody when the warning indicators appear on the screen (p. 83).

### Description of warning messages

If messages appear on the screen, follow the instructions.

#### ■ Media

##### Internal memory format error.

- The format of the internal memory of your camcorder has been changed from the default format. You may be able to use the internal memory again after formatting it (p. 71). All the data in the internal memory will be deleted.

##### Playback prohibited.

- You are trying to play back an incompatible disc with your camcorder.
- You are trying to play back an image recorded with a copyright protection signal.

##### ▲ Disc finalized. Cannot record on disc.

- To record on the finalized DVD-RW (VIDEO mode), unfinalize it (p. 73).

##### ▲ Disc error. Remove disc.

- Your camcorder cannot recognize the disc, because the disc is incompatible or has scratches.

##### ▲ Disc error. Unsupported format.

- The disc is recorded in the different format code from your camcorder. Formatting the disc may enable you to use the disc on your camcorder (DVD-RW/DVD+RW only) (p. 71).

##### Reinsert the Memory Stick.

- Reinsert the “Memory Stick PRO Duo” media a few times. If even then the indicator flashes, the “Memory Stick PRO Duo” media could be damaged. Try with another “Memory Stick PRO Duo” media.

##### This Memory Stick is not formatted correctly.

- Check the format, then format the “Memory Stick PRO Duo” media with your camcorder if necessary (p. 71).

##### Still picture folder is full. Cannot record still pictures.

- You cannot create folders exceeding 999MSDCF. You cannot create or delete created folders using your camcorder.
- Format the “Memory Stick PRO Duo” media (p. 71), or delete unnecessary folders using your computer.

##### This Memory Stick may not be able to record or play movies.

- Use the recommended “Memory Stick” media (p. 5).

##### This Memory Stick may not be able to record or play images correctly.

- Use the recommended “Memory Stick” media (p. 5).

##### Do not eject the Memory Stick during writing. Data may be damaged.

- Insert the “Memory Stick PRO Duo” media again, and follow the instructions on the screen.

---

**The Image Database File is damaged. Do you want to create a new file?**

- The image database file is damaged. When you touch [YES], a new image database file is created. The old recorded images on the “Memory Stick PRO Duo” media cannot be played back (Image files are not damaged). If you perform [REPAIR IMG.DB F.] (p. 75) after creating new image database file, playing back the old recorded images may become possible. If it does not work, copy the image to a computer using the supplied software.

---

**Inconsistencies found in Image Database File. Movies cannot be recorded or played. Do you want to repair the Image Database File?**

- The image database file is damaged. Touch [YES] to repair.

**■ Others**

---

**No further selection is possible.**

- To a Playlist, you can add 99 movies on the internal memory (DCR-DVD450E/DVD850E) or “Memory Stick PRO Duo” media, or 999 movies on a disc (p. 59).
- The maximum number of images that you can select on the INDEX screen at one time is 100 when:
  - deleting images
  - protecting images, or releasing the protection
  - dubbing movies
  - copying still images
  - editing a Playlist

---

**Data protected.**

- The image has been protected. Cancel the protection.

---

**Cannot recover data.**

- Writing data to the media has failed. Attempts were made to recover the data, but they were unsuccessful.

---

**Please wait.**

- This is displayed if the disc removal process takes time. Turn on the camcorder and leave it for about 10 minutes, preventing vibration.
-

## Using your camcorder abroad

### Power supply

You can use your camcorder in any countries/regions using the AC Adaptor supplied with your camcorder within the AC 100 V to 240 V, 50 Hz/60 Hz range.

### On TV color systems

Your camcorder is a PAL-system-based camcorder. If you want to view the playback image on a TV, it must be a PAL-system-based TV with an AUDIO/VIDEO input jack.

System	Used in
PAL	Australia, Austria, Belgium, China, Czech Republic, Denmark, Finland, Germany, Holland, Hong Kong, Hungary, Italy, Kuwait, Malaysia, New Zealand, Norway, Poland, Portugal, Singapore, Slovak Republic, Spain, Sweden, Switzerland, Thailand, United Kingdom, etc.
PAL - M	Brazil
PAL - N	Argentina, Paraguay, Uruguay
NTSC	Bahama Islands, Bolivia, Canada, Central America, Chile, Colombia, Ecuador, Guyana, Jamaica, Japan, Korea, Mexico, Peru, Surinam, Taiwan, the Philippines, the U.S.A., Venezuela, etc.
SECAM	Bulgaria, France, Guiana, Iran, Iraq, Monaco, Russia, Ukraine, etc.

## Setting to the local time

You can easily set the clock to the local time by setting a time difference when using your camcorder abroad. Touch **HOME** → **SETTINGS** → **[CLOCK/ LANG]** → **[AREA SET]** and **[SUMMERTIME]** (p. 84).

## World time difference

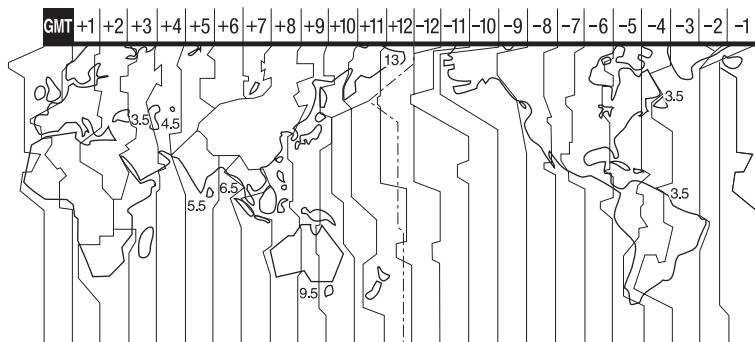

Time-zone differences	Area setting
GMT	Lisbon, London
+01:00	Berlin, Paris
+02:00	Helsinki, Cairo, Istanbul
+03:00	Moscow, Nairobi
+03:30	Tehran
+04:00	Abu Dhabi, Baku
+04:30	Kabul
+05:00	Karachi, Islamabad
+05:30	Calcutta, New Delhi
+06:00	Almaty, Dhaka
+06:30	Yangon
+07:00	Bangkok, Jakarta
+08:00	Hong Kong, Singapore, Beijing
+09:00	Seoul, Tokyo
+09:30	Adelaide, Darwin
+10:00	Melbourne, Sydney

Time-zone differences	Area setting
+11:00	Solomon Is.
+12:00	Fiji, Wellington, Eniwetok, Kwajalein
-11:00	Samoa
-10:00	Hawaii
-09:00	Alaska
-08:00	Los Angeles, Tijuana
-07:00	Denver, Arizona
-06:00	Chicago, Mexico City
-05:00	New York, Bogota
-04:00	Santiago
-03:30	St. John's
-03:00	Brasilia, Montevideo
-02:00	Fernando de Noronha
-01:00	Azores, Cape Verde Is.

# File/folder structure on the internal memory (DCR-DVD450E/DVD850E) and “Memory Stick PRO Duo” media

The file/folder structure is shown below. You do not usually need to acknowledge the file/folder structure, when recording/playing back images on the camcorder. To enjoy still images or movies by connecting to a computer, see “PMB Guide” (p. 97) on the supplied CD-ROM, then use the supplied application.

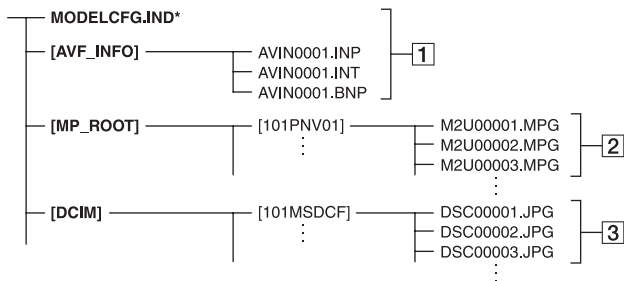

\* Internal memory only (DCR-DVD450E/DVD850E)

## 1 Image database files

When you delete the files, you cannot record/play back the images correctly. The files are defaulted as hidden files and not usually displayed.

## 2 Movie files (MPEG2 files)

The extension of the files is “.MPG”. The maximum size is 2 GB. When the capacity of a file exceeds 2 GB, the file becomes divided.

The file numbers go up automatically. When the capacity of a file number exceeds 9,999, another folder is created to record new movie files.

The folder name goes up: [101PNV01]  
→ [102PNV01]

## 3 Still image files (JPEG files)

The extension of the files is “.JPG”. The file numbers go up automatically. When the capacity of a file number exceeds 9,999, another folder is created to store new image files.

The folder name goes up: [101MSDCF]  
→ [102MSDCF]

- You can access the media in the camcorder from a computer connected by the USB cable (p. 95).
- Do not modify the files or folders in the camcorder from a computer. The image files may be destroyed or may not be played back.
- We (Sony) will not be responsible for the results of operating the data on the media in the camcorder from a computer.
- When you delete image files, follow the steps on page 48. Do not delete the image files on the media in the camcorder directly from a computer.
- Do not format the media in the camcorder using a computer. The camcorder may not operate correctly.
- Do not copy the files on “Memory Stick PRO Duo” media in the camcorder from a computer. We (Sony) will not be responsible for the results of this kind of operation.

# Maintenance and precautions

## About the disc

See page 12 for the details of discs which you can use with your camcorder.

## Notes on use

- Hold the disc by its edge while supporting the center hole lightly. Do not touch the recording side (the opposite of the printed side when using a single-sided disc).



- Before shooting, be sure to remove dust and fingerprints from the disc with a soft cloth. Otherwise you may not be able to record or play normally in some situations using that disc.
- When you set the disc in your camcorder, press firmly until it clicks. When the message [C:13:□□] appears on the LCD screen, open the disc cover and set the disc again.
- Do not attach any adhesive material such as a sticker on the surface of a disc. If you do so, the disc may become unbalanced, and this may cause a malfunction of the disc or your camcorder.



## Use of double-sided discs

Double-sided discs allow you to record both sides of a disc.

## Recording on the A side

Place the disc in your camcorder with the side with the **A** symbol at the center facing outwards until it clicks.

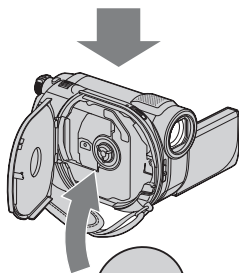
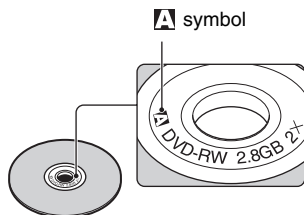

Place the **A** symbol facing outwards. Recording is made on the rear side.

- When using a double-sided disc, take care not to smudge the surface with fingerprints.
- When a double-sided disc is used in your camcorder, recording/playback are performed on that side only. You cannot switch to record on or play back the other side with the disc set to the camcorder. When recording/playback of one side is complete, remove the disc and turn it over to access the other side.
- Perform the following operations on each side of a double-sided disc:
  - Finalizing (p. 66)
  - Formatting (p. 71)
  - Unfinalizing (p. 73)

## Maintenance and precautions (Continued)

### Care and storage of the discs

- Keep the disc clean, or the image quality of the audio and video output may deteriorate.
- Clean the disc with a soft cloth.  
Wipe the disc from the center out. For dirt, clean the disc with a soft cloth slightly moistened in water, then remove the moisture with a soft, dry cloth. Do not use solvents such as benzene, cleaners intended for vinyl LPs or antistatic spray, as they may cause a malfunction to the disc.



- Do not expose the disc to direct sunlight or leave it in a humid place.
- When you carry or store the disc, put it in its case.
- When you want to write letters or marks, etc. on a single-sided disc, write only on the printed side using an oil-based marker with a felt-tip, and do not touch the ink until it dries. Do not heat the disc or use a sharp-pointed tool, such as ball point pen. Do not dry the surface by heating. You cannot write, or mark, on double-sided discs.

### About the “Memory Stick” media

“Memory Stick” media is compact, portable IC recording media with large data capacity.

You can use only “Memory Stick Duo” media, which is about the half size of standard “Memory Stick” media, with your camcorder. However, we do not guarantee the operation of all types of “Memory Stick Duo” media on your camcorder.

Types of “Memory Stick” media	Recording/Playback
“Memory Stick Duo” media (with MagicGate)	-
“Memory Stick PRO Duo” media	○

Types of “Memory Stick” media	Recording/Playback
“Memory Stick PRO-HG Duo” media	○*

- \* Your camcorder is not compatible with 8-bit parallel data transfer, but performs 4-bit parallel data transfer, which is used by “Memory Stick PRO Duo” media.
- This product cannot record or play data that uses “MagicGate” technology. “MagicGate” is a copyright protection technology that records and transfers the contents in an encrypted format.
- This product is compatible with “Memory Stick Micro” media (“M2”). “M2” is the abbreviation for the “Memory Stick Micro” media.
- “Memory Stick PRO Duo” media formatted by a computer (Windows OS/Mac OS) does not have guaranteed compatibility with your camcorder.
- Data read/write speed may vary depending on the combination of the “Memory Stick PRO Duo” media and the “Memory Stick PRO Duo” media compliant product you use.
- Damaged or lost data may occur in the following cases (the data will not be compensated for):
  - If you eject the “Memory Stick PRO Duo” media, or turn off your camcorder while your camcorder is reading or writing image files on the “Memory Stick PRO Duo” media (while the access lamp is lit or flashing).
  - If you use the “Memory Stick PRO Duo” media near magnets or magnetic fields.
- It is recommended you make a back-up of important data on the hard disk of a computer.
- Be careful not to apply excessive force when writing on a memo area on “Memory Stick PRO Duo” media.
- Do not attach a label or the like on “Memory Stick PRO Duo” media or a “Memory Stick Duo” media adaptor.
- When you carry or store “Memory Stick PRO Duo” media, put it in its case.
- Do not touch, or allow metallic objects to come into contact with the terminals.
- Do not bend, drop or apply strong force to the “Memory Stick PRO Duo” media.
- Do not disassemble or modify the “Memory Stick PRO Duo” media.

- Do not let the “Memory Stick PRO Duo” media get wet.
- Keep the “Memory Stick PRO Duo” media out of the reach of small children. They might accidentally swallow it.
- Do not insert anything other than “Memory Stick PRO Duo” media into the “Memory Stick Duo” media slot. Doing so may cause a malfunction.
- Do not use or keep the “Memory Stick PRO Duo” media in the following locations:
  - Places subject to extremely high temperature, such as a car parked outside in the summer
  - Places under direct sunlight
  - Places with extremely high humidity or subject to corrosive gases

### ■ On the “Memory Stick Duo” media adaptor

- When using “Memory Stick PRO Duo” media with a “Memory Stick” media compliant device, be sure to insert the “Memory Stick PRO Duo” media into a “Memory Stick Duo” media adaptor.
- When inserting “Memory Stick PRO Duo” media into a “Memory Stick Duo” media adaptor, make sure the “Memory Stick PRO Duo” media is inserted facing in the correct direction, then insert it all the way in. Note that improper use may cause a malfunction. Also, if you force the “Memory Stick PRO Duo” media into the “Memory Stick Duo” media adaptor in the wrong direction, it may be damaged.
- Do not insert a “Memory Stick Duo” media adaptor without “Memory Stick PRO Duo” media attached into a “Memory Stick” media compliant device. Doing so may result in malfunctions of the device.

### ■ On “Memory Stick PRO Duo” media

- Up to 16 GB “Memory Stick PRO Duo” media and up to 8 GB “Memory Stick PRO-HG Duo” media are guaranteed for use with your camcorder.

## Notes on using “Memory Stick Micro” media

- To use “Memory Stick Micro” media with your camcorder, you need a Duo-sized M2 Adaptor. Insert the “Memory Stick Micro” media into the Duo-sized M2 Adaptor, and then insert the adaptor into the “Memory Stick Duo” media slot. If you insert “Memory Stick Micro” media into your camcorder without using a Duo-sized M2 Adaptor, you might not be able to remove it from your camcorder.
- Keep the “Memory Stick Micro” media out of the reach of small children. They might accidentally swallow it.

## On image data compatibility

- Image data files recorded on “Memory Stick PRO Duo” media by your camcorder conform to the “Design rule for Camera File system” universal standard established by the JEITA (Japan Electronics and Information Technology Industries Association).
- On your camcorder, you cannot play back still images recorded on other devices (DCR-TRV900E or DSC-D700/D770) that do not conform to the universal standard. (These models are not sold in some regions.)
- If you cannot use “Memory Stick PRO Duo” media that has been used with another device, format it with your camcorder (p. 71). Note that formatting erases all information on the “Memory Stick PRO Duo” media.
- You may not be able to play back images with your camcorder:
  - if image data are modified on a computer.
  - if image data are recorded with other devices.

## About the “InfoLITHIUM” battery pack

Your camcorder operates only with an “InfoLITHIUM” battery pack (H series). “InfoLITHIUM” H series battery packs have the  mark.

### What is an “InfoLITHIUM” battery pack?

An “InfoLITHIUM” battery pack is a lithium-ion battery pack that has functions for communicating information related to operating conditions between your camcorder and an optional AC Adaptor/charger.

The “InfoLITHIUM” battery pack calculates the power consumption according to the operating conditions of your camcorder, and displays the remaining battery time in minutes.

With an AC Adaptor/charger, the remaining battery time and charging time appear.

### To charge the battery pack

- Be sure to charge the battery pack before you start using your camcorder.
- We recommend charging the battery pack in an ambient temperature of between 10 °C to 30 °C (50 °F to 86 °F) until the CHG (charge) lamp turns off. If you charge the battery pack outside of this temperature range, you may not be able to charge it efficiently.
- After charging is complete, disconnect the AC Adaptor from the DC IN jack on your camcorder or remove the battery pack.

### To use the battery pack effectively

- Battery pack performance decreases when the ambient temperature is 10 °C (50 °F) or below, and the length of time you can use the battery pack becomes shorter. In that case, do one of the followings to use the battery pack for a longer time.
  - Put the battery pack in a pocket to warm it up, and insert it in your camcorder right before you start taking shots.
  - Use a large capacity battery pack: NP-FH70/NP-FH100 (sold separately).
- Frequent use of the LCD screen or a frequent playback, fast forward or reverse operation wears out the battery pack faster.

We recommend using a large capacity battery pack: NP-FH70/NP-FH100 (sold separately).
- Be sure to set the POWER switch to OFF (CHG) when not recording or playing back on your camcorder. The battery pack is also



consumed when your camcorder is in recording standby or playback pause.

- Have spare battery packs ready for 2 or 3 times the expected recording time, and make trial recordings.
- Do not expose the battery pack to water. The battery pack is not water resistant.

### About the remaining battery time indicator

- When the power goes off even though the remaining battery time indicator indicates that the battery pack has enough power to operate, charge the battery pack fully again. Remaining battery time will be indicated correctly. Note, however, that the battery indication will not be restored if it is used in high temperatures for a long time, or if left in a fully charged state, or when the battery pack is frequently used. Use the remaining battery time indication as a rough guide only.
- The  mark that indicates low battery flashes even if there are still 20 minutes of battery time remaining, depending on the operating conditions or ambient temperature.

### About storage of the battery pack

- If the battery pack is not used for a long time, fully charge the battery pack and use it up on your camcorder once a year to maintain proper function. To store the battery pack, remove it from your camcorder and put it in a dry, cool place.
- To discharge the battery pack on your camcorder completely, touch  (HOME) →  (SETTINGS) → [GENERAL SET] → [A.SHUT OFF] → [NEVER] and leave your camcorder in recording standby until the power goes off (p. 85).

### About battery life

- Battery capacity decreases over time and through repeated use. If decreased usage time between charges becomes significant, it is probably time to replace it with a new one.
- Each battery's life is governed by storage, operating and environmental conditions.

## About handling of your camcorder

### On use and care

- Do not use or store the camcorder and accessories in the following locations:
  - Anywhere extremely hot, cold, or humid. Never leave them exposed to temperatures above 60 °C (140 °F), such as under direct sunlight, near heaters or in a car parked in the sun. They may malfunction or become deformed.
  - Near strong magnetic fields or mechanical vibration. The camcorder may malfunction.
  - Near strong radio waves or radiation. The camcorder may not be able to record properly.
  - Near AM receivers and video equipment. Noise may occur.
  - On a sandy beach or anywhere dusty. If sand or dust gets in your camcorder, it may malfunction. Sometimes this malfunction cannot be repaired.
  - Near windows or outdoors, where the LCD screen, the viewfinder, or the lens may be exposed to direct sunlight. This damages the inside of the viewfinder or the LCD screen.
- Operate your camcorder on DC 6.8 V/7.2 V (battery pack) or DC 8.4 V (AC Adaptor).
- For DC or AC operation, use the accessories recommended in these operating instructions.
- Do not let your camcorder get wet, for example, from rain or sea water. If your camcorder gets wet, it may malfunction. Sometimes this malfunction cannot be repaired.
- If any solid object or liquid gets inside the casing, unplug your camcorder and have it checked by a Sony dealer before operating it any further.
- Avoid rough handling, disassembling, modifying, physical shock, or impact such as hammering, dropping or stepping on the product. Be particularly careful of the lens.
- Keep the POWER switch setting to OFF (CHG) when you are not using your camcorder.
- Do not wrap your camcorder with a towel, for example, and operate it. Doing so might cause heat to build up inside.
- When disconnecting the power cord (mains lead), pull it by the plug and not the cord.

- Do not damage the power cord (mains lead) such as by placing anything heavy on it.
- Keep metal contacts clean.
- If the battery electrolytic liquid has leaked:
  - consult your local authorized Sony service facility.
  - wash off any liquid that may have contacted your skin.
  - if any liquid gets in your eyes, wash with plenty of water and consult a doctor.

### ■ When not using your camcorder for a long time

- Periodically turn it on and let it run such as by playing back or recording images for about 3 minutes.
- Remove a disc from your camcorder.
- Use up the battery pack completely before storing it.

### Moisture condensation

If your camcorder is brought directly from a cold place to a warm place, moisture may condense inside your camcorder, on the surface of the disc, or on the pickup lens. This may cause a malfunction to your camcorder.

### ■ If moisture condensation has occurred

Leave your camcorder for about 1 hour without turning it on.

### ■ Note on moisture condensation

Moisture may condense when you bring your camcorder from a cold place into a warm place (or vice versa) or when you use your camcorder in a humid place as follows:

- You bring your camcorder from a ski slope into a place warmed up by a heating device.
- You bring your camcorder from an air conditioned car or room into a hot place outside.
- You use your camcorder after a squall or a shower.
- You use your camcorder in a hot and humid place.

## Maintenance and precautions (Continued)

### ■ How to prevent moisture condensation

When you bring your camcorder from a cold place into a warm place, put your camcorder in a plastic bag and seal it tightly. Remove the bag when the air temperature inside the plastic bag has reached the ambient temperature after about 1 hour.

### LCD screen



- Do not exert excessive pressure on the LCD screen, as it may cause damage.
- If your camcorder is used in a cold place, a residual image may appear on the LCD screen. This is not a malfunction.
- While using your camcorder, the back of the LCD screen may heat up. This is not a malfunction.

### ■ To clean the LCD screen

If fingerprints or dust make the LCD screen dirty, it is recommended you use a soft cloth to clean it. When you use the LCD Cleaning Kit (sold separately), do not apply the cleaning liquid directly to the LCD screen. Use cleaning paper moistened with the liquid.

### ■ On adjustment of the touch panel (CALIBRATION)

The buttons on the touch panel may not work correctly. If this happens, follow the procedure below. It is recommended that you connect your camcorder to the wall outlet (wall socket) using the supplied AC Adaptor during the operation.

- ① Turn on your camcorder.
- ② Touch  (HOME) →  (SETTINGS) → [GENERAL SET] → [CALIBRATION].

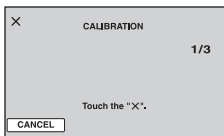

- ③ Touch "X" displayed on the screen 3 times with the corner of "Memory Stick PRO Duo" media or the like. The position of "X" changes.

Touch [CANCEL] to cancel.

If you did not press the right spot, try the calibration again.

### 🔊 Notes

- Do not use a sharp-pointed object for calibration. Doing so may damage the LCD screen.
- You cannot calibrate the LCD screen if it is rotated, or closed with the screen facing out.

### On handling the casing

- If the casing is soiled, clean the camcorder body with a soft cloth lightly moistened with water, and then wipe the casing with a dry soft cloth.
- Avoid the following to avoid damage to the finish:
  - Using chemicals such as thinner, benzine, alcohol, chemical cloths, repellent, insecticide and sunscreen
  - Handling the camcorder with above substances on your hands
  - Leaving the casing in contact with rubber or vinyl objects for a long period of time

## On the pickup lens

- Do not touch the pickup lens inside the disc cover. Keep the disc cover closed except when inserting and removing the disc, to keep dust out.
- When your camcorder does not work because the pickup lens is dirty, clean it with a camera blower (sold separately). Do not touch the pickup lens directly during cleaning, because this may cause the camcorder to malfunction.

Pickup lens

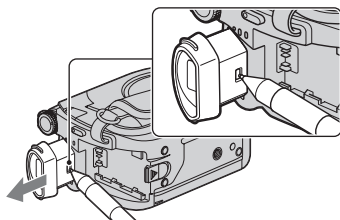
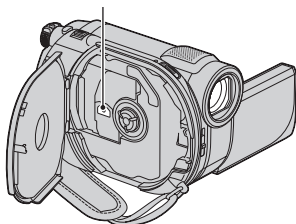

- ③ Remove dust from the eyecup block with a camera blower, etc.

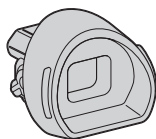

- ④ Press the viewfinder onto the body of the camcorder.
- ⑤ Remove dust from the inside area where the eyecup block was attached with a camera blower, etc.

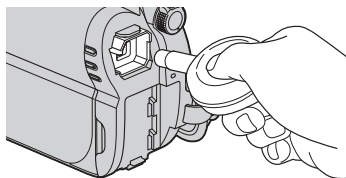

- ⑥ Attach the eyecup block to the viewfinder, pushing it straight on until it clicks.

## About care and storage of the lens

- Wipe the surface of the lens clean with a soft cloth in the following instances:
  - When there are fingerprints on the lens surface.
  - In hot or humid locations
  - When the lens is exposed to salty air such as at the seaside.
- Store in a well-ventilated location subject to little dirt or dust.
- To prevent mold, periodically clean the lens as described above. It is recommended that you operate your camcorder about once a month to keep it in optimum state for a long time.

## Cleaning inside the viewfinder

Remove any dust from inside the viewfinder by following the steps below.

- ① Pull out the viewfinder.
- ② While pushing in the tab on the bottom of the viewfinder with a fine-tipped object such as a ball point pen, pull the eyecup block in the direction of the arrow to remove.

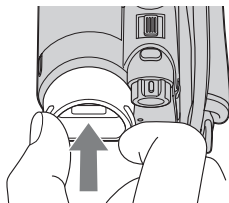

### ⚠ Notes

- The eyecup block is a precision part. Do not disassemble it further.
- Do not touch the lens of the eyecup block.

### On charging the pre-installed rechargeable battery

Your camcorder has a pre-installed rechargeable battery to retain the date, time, and other settings even when the POWER switch is set to OFF (CHG). The pre-installed rechargeable battery is always charged while your camcorder is connected to the wall outlet (wall socket) via the AC Adaptor or while the battery pack is attached. The pre-installed rechargeable battery will be fully discharged in about **3 months** if you do not use your camcorder at all. Use your camcorder after charging the pre-installed rechargeable battery. However, even if the pre-installed rechargeable battery is not charged, the camcorder operation will not be affected as long as you are not recording the date.

#### ■ Procedures

Connect your camcorder to a wall outlet (wall socket) using the supplied AC Adaptor, and leave it with the POWER switch set to OFF (CHG) for more than 24 hours.

# Specifications

## System

### Video compression format

MPEG2/JPEG (Still images)

### Audio compression format

DCR-DVD150E/DVD650E

Dolby Digital 2ch

Dolby Digital Stereo Creator

DCR-DVD450E/DVD850E

Dolby Digital 2ch/5.1ch

Dolby Digital 5.1 Creator

### Video signal

PAL color, CCIR standards

### Internal memory (DCR-DVD450E/

### DVD850E)

16 GB

When measuring media capacity, 1 GB equals 1 billion bytes, a portion of which is used for data management.

### Usable discs

8 cm DVD-RW/DVD+RW/DVD-R/

DVD+R DL

### Movie recording format

Internal memory (DCR-DVD450E/

DVD850E)

MPEG2-PS

Disc

DVD-RW: DVD-VIDEO (VIDEO mode),

DVD-Video Recording (VR mode)

DVD+RW: DVD+RW Video

DVD-R/DVD+R DL: DVD-VIDEO

“Memory Stick PRO Duo” media

MPEG2-PS

### Still image recording format

DCF Ver.2.0 Compatible

Exif Ver.2.21 Compatible

MPF Baseline Compatible

### Viewfinder

Electric viewfinder (color)

### Image device

2.25 mm (1/8 type) CCD (Charge Coupled Device)

Gross:

Approx. 800 000 pixels

Effective (Movie, 16:9)

Approx. 490 000 pixels

Effective (Still, 16:9)

Approx. 310 000 pixels

Effective (Still, 4:3)

Approx. 410 000 pixels

## Lens

Carl Zeiss Vario-Tessar

Optical: 60×, Digital: 120×, 2 000×

Filter diameter: 30 mm (1 3/16 in.)

### Focal length

F 1.8 - 6.0

f = 1.8 - 108 mm (3/32 - 4 3/8 in.)

When converted to a 35 mm still camera

For movies:

39 - 2 340 mm (1 9/16 - 92 1/4 in.) (16:9)

For still images:

44 - 2 640 mm (1 3/4 - 104 in.) (4:3)

### Color temperature

[AUTO], [ONE PUSH], [INDOOR]

(3 200 K), [OUTDOOR] (5 800 K)

### Minimum illumination

6 lx (lux) ([AUTO SLW SHUTTR] [ON],

Shutter speed 1/25 second)

## Input/Output connectors

### A/V Remote Connector

Video/audio output jack

### USB jack

mini-B

(DCR-DVD150E/DVD450E: output only)

## LCD screen

### Picture

6.7 cm (2.7 type, aspect ratio 16:9)

### Total number of pixels

123 200 (560 × 220)

## Specifications (Continued)

### General

#### Power requirements

DC 6.8 V/7.2 V (battery pack)

DC 8.4 V (AC Adaptor)

#### Average power consumption

DCR-DVD150E/DVD650E

Using the LCD screen (normal brightness):

2.4 W

Using the Viewfinder: 2.2 W

DCR-DVD450E/DVD850E

Using the LCD screen (normal brightness):

2.1 W

Using the Viewfinder: 1.9 W

#### Operating temperature

0 °C to 40 °C (32 °F to 104 °F)

#### Storage temperature

-20 °C to +60 °C (-4 °F to +140 °F)

#### Dimensions (Approx.)

55 × 89 × 130 mm (2 1/4 × 3 5/8 × 5 1/8 in.)

(w×h×d) including the projecting parts

55 × 89 × 130 mm (2 1/4 × 3 5/8 × 5 1/8 in.)

(w×h×d) including the projecting parts with

the rechargeable battery pack NP-FH30

attached

#### Mass (Approx.)

DCR-DVD150E/DVD650E

390 g (13 oz) main unit only

440 g (15 oz) including the rechargeable battery pack NP-FH30 and a disc

DCR-DVD450E/DVD850E

390 g (13 oz) main unit only

430 g (15 oz) including the rechargeable battery pack NP-FH30

#### Supplied accessories

See page 19.

### AC Adaptor AC-L200C/AC-L200D

#### Power requirements

AC 100 V - 240 V, 50 Hz/60 Hz

#### Current consumption

0.35 A - 0.18 A

#### Power consumption

18 W

#### Output voltage

DC 8.4 V\*

#### Operating temperature

0 °C to 40 °C (32 °F to 104 °F)

#### Storage temperature

-20 °C to +60 °C (-4 °F to +140 °F)

#### Dimensions (Approx.)

48 × 29 × 81 mm (1 15/16 × 1 3/16 × 3 1/4 in.)

(w×h×d) excluding the projecting parts

#### Mass (Approx.)

170 g (6.0 oz) excluding the power cord

(mains lead)

\* See at the label of the AC Adaptor for other specifications.

### Rechargeable battery pack NP-FH30

#### Maximum output voltage

DC 8.4 V

#### Output voltage

DC 7.2 V

#### Maximum charge voltage

DC 8.4 V

#### Maximum charge current

2.12 A

#### Capacity

3.6 Wh (500 mAh)

#### Type

Li-ion

Design and specifications are subject to change without notice.

- Manufactured under license from Dolby Laboratories.

## On trademarks

- “Handycam” and **HANDYCAM** are registered trademarks of Sony Corporation.
- “Memory Stick,”  “Memory Stick Duo,” **MEMORY STICK DUO**, “Memory Stick PRO Duo,” **MEMORY STICK PRO DUO**, “Memory Stick PRO-HG Duo,” **MEMORY STICK PRO-HG DUO**, “Memory Stick Micro,” “MagicGate,” **MAGIC GATE**, “MagicGate Memory Stick” and “MagicGate Memory Stick Duo” are trademarks or registered trademarks of Sony Corporation.
- “InfoLITHIUM” is a trademark of Sony Corporation.
- DVD-RW, DVD+RW, DVD-R, and DVD+R DL logo are trademarks.
- Dolby and the double-D symbol are trademarks of Dolby Laboratories.
- Microsoft, Windows, Windows Media, Windows Vista and DirectX are either registered trademarks or trademarks of Microsoft Corporation in the United States and/or other countries.
- Macintosh and Mac OS are registered trademarks of Apple Inc. in the U.S. and other countries.
- Intel, Intel Core, and Pentium are trademarks or registered trademarks of Intel Corporation or its subsidiaries in the United States and other countries.
- Adobe, the Adobe logo, and Adobe Acrobat are either registered trademarks or trademarks of Adobe Systems Incorporated in the United States and/or other countries.

All other product names mentioned herein may be the trademarks or registered trademarks of their respective companies. Furthermore, <sup>TM</sup> and © are not mentioned in each case in this manual.

## Notes on the License

ANY USE OF THIS PRODUCT OTHER THAN CONSUMER PERSONAL USE IN ANY MANNER THAT COMPLIES WITH THE MPEG-2 STANDARD FOR ENCODING VIDEO INFORMATION FOR PACKAGED MEDIA IS EXPRESSLY PROHIBITED WITHOUT A LICENSE UNDER APPLICABLE PATENTS IN THE MPEG-2 PATENT PORTFOLIO, WHICH LICENSE IS AVAILABLE FROM MPEG LA, L.L.C., 250 STEELE STREET, SUITE 300, DENVER, COLORADO 80206.

“C Library,” “Expat,” “zlib,” and “libjpeg” software are provided in your camcorder. We provide this software based on license agreements with their owners of copyright. Based on requests by the owners of copyright of these software applications, we have an obligation to inform you of the following. Please read the following sections.

Read “license1.pdf” in the “License” folder on the CD-ROM. You will find licenses (in English) of “C Library,” “Expat,” “zlib,” and “libjpeg” software.

## On GNU GPL/LGPL applied software

The software that is eligible for the following GNU General Public License (hereinafter referred to as “GPL”) or GNU Lesser General Public License (hereinafter referred to as “LGPL”) are included in the camcorder.

This informs you that you have a right to have access to, modify, and redistribute source code for these software programs under the conditions of the supplied GPL/LGPL.

Source code is provided on the web. To download, go to the following website and select DCR-SR87.

<http://www.sony.net/Products/Linux/>

We would prefer you do not contact us about the contents of source code.

Read “license2.pdf” in the “License” folder on the CD-ROM. You will find licenses (in English) of “GPL,” and “LGPL” software.

To view the PDF, Adobe Reader is needed. If it is not installed on your computer, you can download it from the Adobe Systems web page:

<http://www.adobe.com/>

# Identifying parts and controls

The numbers in ( ) are reference pages.

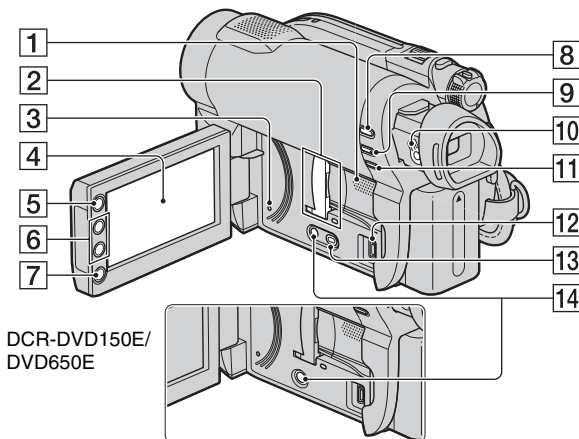

**1** Speaker (34, 42)  
Playback sounds come out from the speaker. For how to adjust the volume, see page 42.

**2** “Memory Stick Duo” media slot/cover and access lamp (30)  
The access lamp lights for both the internal memory\* and “Memory Stick PRO Duo” media.

**3** RESET button  
Initializes all the settings, including the setting of the date and time.

**4** LCD screen/touch panel (16, 25)

**5**  (HOME) button (17, 77)

**6** Zoom buttons (38, 43)

**7** START/STOP button (32, 37)

**8**  (VIEW IMAGES) button (33, 40)

**9** EASY button (32)

**10** Viewfinder lens adjustment lever (25)

**11**  (Backlight) button (39)



**12**  (USB) jack (63)  
DCR-DVD150E/DVD450E:  
Output only

**13** DUBBING button\* (52)

**14** DISP button (25)

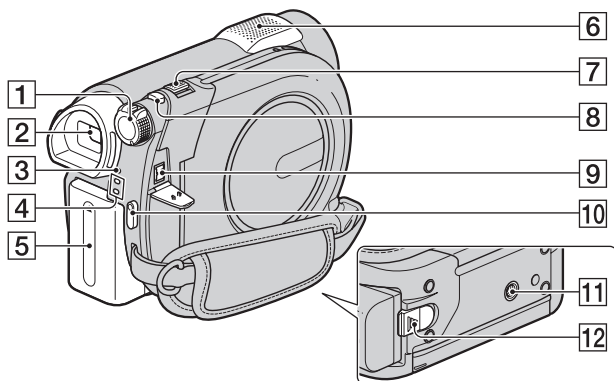
\* DCR-DVD450E/DVD850E



- 1** POWER switch (23)
- 2** Viewfinder (25)
- 3** CHG (charge) lamp (20)
- 4**  (Movie)/  (Still) mode lamps (23)
- 5** Battery pack (20)
- 6** Built-in microphone (38)
- 7** Power zoom lever (38, 43)
- 8** PHOTO button (32, 37)
- 9** DC IN jack (20)
- 10** START/STOP button (32, 37)
- 11** Tripod receptacle  
Attach the tripod (sold separately: the length of the screw must be less than 5.5 mm (7/32 in.)) to the tripod receptacle using a tripod screw.
- 12** BATT (battery) release lever (21)

## Identifying parts and controls (Continued)

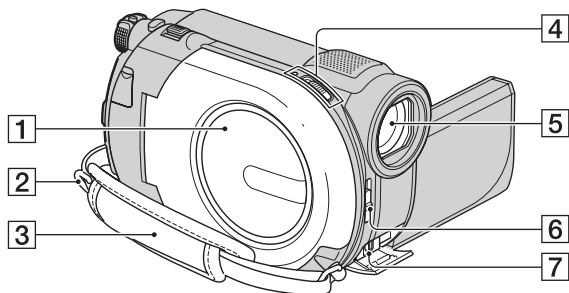

- 1** Disc cover (28)
- 2** Hook for a shoulder belt  
Attach a shoulder belt (sold separately).
- 3** Grip belt (25)
- 4** Disc cover OPEN switch and ACCESS lamp (28)
- 5** Lens (Carl Zeiss Lens) (7)
- 6** LENS COVER switch (25)
- 7** A/V Remote Connector (45, 62)  
Connect other optional accessories.

# Indicators displayed during recording/playback

## Recording movies

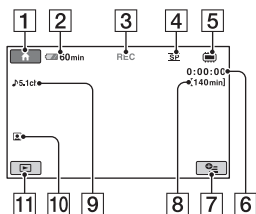

## Recording still images

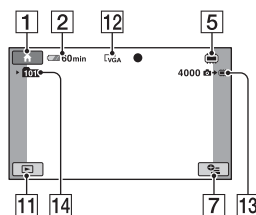

## Viewing movies

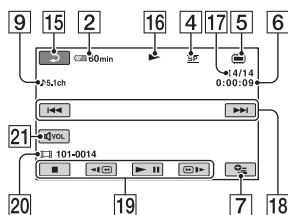

## Viewing still images

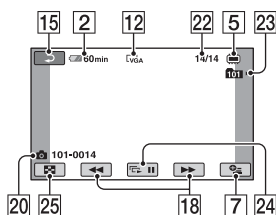

- 1 HOME button (17, 77)
- 2 Remaining battery (approx.) (64)
- 3 Recording status ([STBY] (standby) or [REC] (recording))
- 4 Recording mode (HQ/SP/LP) (79)
- 5 Media type (12)
- 6 Counter (hour/minute/second)
- 7 OPTION button (18, 86)
- 8 Approximate remaining recordable time of movies
- 9 Audio mode (79) (DCR-DVD450E/DVD850E)
- 10 Face Index set (80)
- 11 VIEW IMAGES button (33, 40)
- 12 Image size (81)
- 13 Approximate remaining recordable number of still images (81, 81)
- 14 Recording folder  
When [PHOTO MEDIA SET] is [MEMORY STICK]
- 15 Return button
- 16 Playback mode
- 17 Current movie number/Total number of recorded movies  
When [MOVIE MEDIA SET] is [INT. MEMORY] (DCR-DVD450E/DVD850E) or [MEMORY STICK]
- 18 Previous/Next button (33, 41)
- 19 Video operation buttons (33, 41)
- 20 Data file name/Scene number
- 21 Volume (33, 41)
- 22 Current still image number/Total number of recorded still images
- 23 Playback folder  
When [PHOTO MEDIA SET] is [MEMORY STICK]
- 24 Slide show button (44)
- 25 VISUAL INDEX button (33, 40)

## Indicators displayed during recording/playback (Continued)

### Screen indicators

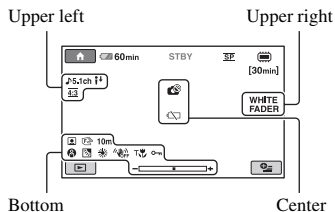

#### Upper left

Indicator	Meaning
5.1ch 2ch	Audio mode (79)
↓	MICREF LEVEL low (92)
4:3	WIDE SELECT (79)
🕒	Self-timer recording (92)
📶	BLT-IN ZOOM MIC (92)

#### Upper right

Indicator	Meaning
WHITE FADER BLACK FADER	Fader (91)

#### Center

Indicator	Meaning
🚫 🚫 🚫 🚫	Warning (108)
📷	

#### Bottom

Indicator	Meaning
👤	Face Index set (80)
👁️ 📏 👤	Manual focus (89)
🌙 🔦 🌅	SCENE SELECTION (90)
⚙️ 📏 👤 📷	
👤 📏 📷	
📷	Backlight (39)

Indicator	Meaning
☀️ ☀️ 📷	White balance (91)
👤	SteadyShot off (80)
T	Tele macro (89)
🔒	Protect (55)
📷	SPOT MTR/FCS (88)/ SPOT METER (88)/ EXPOSURE (89)

#### 💡 Tips

- The contents and positions of the indicators illustrated here may differ from the actual indicators on the screen of your camcorder. Some indicators do not appear depending on the model.

### Data code during recording

The recording date, time, and camera setting data are recorded automatically on the media. They are not displayed while recording. However, you can check them as [DATA CODE] during playback (p. 82). You can view the recording date and time on another device, etc. ([SUB-T DATE], p. 85).

# Glossary

## ■ 5.1ch surround sound

A system that plays back sound on 6 speakers, 3 at the front (left, right and center) and 2 at the rear (right and left) with an additional low-pass subwoofer counted as a 0.1 channel for frequencies of 120 Hz or lower.

## ■ Dolby Digital

An audio encoding (compression) system developed by Dolby Laboratories Inc.

## ■ Dolby Digital 5.1 Creator

Sound compression technology developed by Dolby Laboratories Inc. which compresses audio efficiently while preserving high sound quality. It enables recording of 5.1ch surround sound while using disc space more efficiently. Discs created by Dolby Digital 5.1 Creator can be played back on a device compatible with the disc created on your camcorder.

## ■ JPEG

JPEG stands for Joint Photographic Experts Group, a still image data compression (data capacity reduction) standard. Your camcorder records still images in JPEG format.

## ■ MPEG

MPEG stands for Moving Picture Experts Group, the group of standards for the coding (image compression) of video (movie) and audio. There are MPEG1 and MPEG2 formats. Your camcorder records movies in MPEG2 format.

## ■ Thumbnail

Reduced-size images which enable you to view many images at the same time. [VISUAL INDEX], [FILM ROLL], [FACE], etc. are thumbnail display system.

## ■ VBR

VBR stands for Variable Bit Rate, the recording format for automatically controlling the bit rate (the volume of recording data in a given time segment) according to the scene being recorded. For fast-moving video, a lot of media space is used to produce a clear image, so the recording time to the media shortens.

## ■ VIDEO mode

One of the recording formats you can select when using a DVD-RW. VIDEO mode provides excellent compatibility with other DVD devices.

## ■ VR mode

One of the recording formats you can select when using a DVD-RW. VR mode enables editing (deleting or sequence rearrangement) with your camcorder. Finalizing the disc lets you play it back on a VR mode compatible DVD device.

# Index

## Numeric

16:9.....	45
16:9 WIDE .....	29
21-pin adaptor.....	46
4:3.....	29, 45
5.1ch surround recording.....	38
5.1ch surround sound .....	38
8cm DVD .....	12

## A

AC Adaptor .....	20
Additional recording.....	73
AREA SET .....	84
Aspect ratio.....	45
AUDIO MODE .....	79
AUTO SLW SHUTTR (Auto slow shutter) .....	80, 107
A.SHUT OFF (Auto shut off) .....	85
A/V connecting cable ....	45, 62

## B

Backlight .....	39, 107
Battery .....	20
Battery Info.....	64
BEACH .....	90
BEEP .....	83
BLACK FADER .....	91
BLT-IN ZOOM MIC.....	92

## C

CALIBRATION .....	120
CAMERA DATA.....	82
CANDLE.....	90
CD-ROM.....	93
Charging time.....	21
CLOCK SET .....	23
CLOCK/LANG .....	84
Computer.....	93

Connecting	
TV .....	45
VCR or DVD/HDD recorders .....	62
Copying still images .....	53

## D

DATA CODE .....	82
Date Index.....	43
DATE/TIME.....	24, 82, 130
DC IN jack.....	20
DC plug.....	20
DELETE	
Movies .....	48
Still images .....	49
DEMO MODE.....	85
DIGITAL ZOOM .....	79
Disc .....	28
DISC SELECT GUIDE .....	74
DISP OUTPUT .....	84
DIVIDE	
Original.....	58
Playlist.....	61
Dolby Digital 5.1 Creator .....	131
Double-sided disc .....	115
Dubbing movies.....	52, 62
DVD drive.....	69
DVD menu .....	68
DVD-R.....	12
DVD-RW .....	12
DVD+R DL.....	12
DVD+RW .....	12

## E

Easy Handycam operation ...	32
Editing.....	47
EXPOSURE.....	89

## F

Face Index.....	42, 80
-----------------	--------

FACE SET (Face Index set) .....	80
FADER.....	91, 107
FILE NO. (File number).....	81
Film Roll Index .....	42
Finalize .....	66, 106
FIREWORKS.....	90
FOCUS .....	89, 104
FORMAT	
Disc .....	71
Internal memory.....	71
“Memory Stick PRO Duo” media.....	71

## G

GENERAL SET .....	85
Grip belt.....	25
GUIDEFAME.....	80

## H

HOME MENU .....	16, 77
CLOCK/LANG.....	84
GENERAL SET.....	85
MOVIE SETTINGS.....	79
OUTPUT SETTINGS... ..	84
PHOTO SETTINGS .....	81
SOUND/DISP SET .....	83
VIEW IMAGES SET... ..	82
HQ.....	79

## I

IMAGE SIZE .....	81
Indicators .....	130
INDOOR .....	91
InfoLITHIUM .....	117
Install (software) .....	93

## J

JPEG.....	131
-----------	-----

<b>L</b>	LANDSCAPE.....90	OUTPUT SETTINGS.....84	SNOW.....90
	LANGUAGE SET.....84	<b>P</b>	SOUND SETTINGS.....78
	LAST SCENE DEL (delete) .....49	PAL.....112	SOUND/DISP SET.....83
	LCD BL LEVEL (LCD back light level).....83, 104	PHOTO COPY.....53	SP.....79
	LCD BRIGHT.....83	PHOTO SETTINGS.....81	Specifications.....123
	LCD COLOR.....83	Playback.....33, 40	SPORTS (Sports lesson).....90
	LCD panel.....25	Playback zoom.....43	SPOT FOCUS.....88, 107
	Lens cover.....25	Playing time.....22	SPOT METER (Flexible spot meter).....88
	LP.....79	Playlist	SPOT MTR/FCS.....88
<b>M</b>		Creating.....59	SPOTLIGHT.....90
Maintenance.....115		Divide.....61	STEADYSHOT.....80
MANAGE MEDIA category .....65		Erase.....60	Still Images.....32, 37
“Memory Stick” media .....5, 116		Move.....61	SUB-T DATE.....85
“Memory Stick PRO Duo” media.....5, 30, 116		Playback.....60	SUMMERTIME.....84
MICREF LEVEL.....92, 107	PMB Guide.....97		SUNRISE&SUNSET.....90
Mirror mode.....39	PORTRAIT.....90		
Moisture condensation.....119	Power cord (mains lead).....20		<b>T</b>
MOVIE DUB.....52	Precautions.....115		TELE MACRO.....89, 107
MOVIE SETTINGS.....79	Preparation.....20		Tripod.....127
Movies.....32, 37	Protect.....55, 111		TV color system.....112
MPEG.....131			TV TYPE.....45, 84
<b>N</b>			TWILIGHT.....90
NTSC.....112	<b>R</b>		
Number of still images recordable.....81	REC MODE (Recording mode) .....79		<b>U</b>
<b>O</b>	Recording.....32, 36		UNFINALIZE.....73, 106
ONE PUSH.....91	Recording format.....12		USB 2.0.....93
OPTION MENU.....86	Recording time.....13, 21, 31		USB cable.....64, 94
Original	Remaining battery.....64		Using abroad.....112
DELETE.....48	REMAINING SET (Remaining media display setting).....80		
DIVIDE.....58	REPAIR IMG.DB F.....75		<b>V</b>
OTHERS category.....47			VBR.....13
OUTDOOR.....91	<b>S</b>		VIDEO mode.....12
	S video cable.....45, 62		VIEW IMAGES SET.....82
	SCENE SELECTION .....90, 107		VISUAL INDEX.....33, 40
	Self-diagnosis display.....108		VOLUME.....34, 42, 83
	SELF-TIMER.....92		VR mode.....12
	SETTINGS category.....77		
	Slide show.....44		<b>W</b>
			Warning indicators.....108
			Warning messages.....110

## Index (Continued)

WHITE BAL. (White balance) .....	91
WHITE FADER .....	91
WIDE SELECT .....	79
Windows.....	93
World time difference .....	113

## Z

Zoom .....	38
------------	----

