



Texas Thermowell

Thermowells, Protection Tubes, Sample Probes,
Flange Connectors

Catalog 4240

October 2009

aerospace
climate control
electromechanical
filtration
fluid & gas handling
hydraulics
pneumatics
process control
sealing & shielding



ENGINEERING YOUR SUCCESS.

Introduction

Thermowells are recommended for temperature instruments in process systems where pressure, velocity, or viscous, abrasive, and corrosive materials are present individually or in combination. A properly selected thermowell will protect the temperature instrument from damage resulting from these process variables. Additionally, a thermowell enables removal of the temperature instrument for replacement, repair, or testing without affecting the process system.

Parker Texas Thermowell specializes in the design and manufacture of all types of thermowells. The 21 Series thermowell designs shown in this guide are styles that are popular throughout industry. Special designs, as well as modifications of our standard offerings, are also available.

Parker Texas Thermowell is dedicated to unsurpassed quality, on-time delivery, and competitive pricing. This commitment has been recognized by the International Standards Organization (ISO). Our ISO 9001:2008 certification is additional assurance to our customers that their buying decisions can be made every day with a higher level of supplier confidence, and affirms our ongoing commitment to our quality policy –

“Parker Texas Thermowell will deliver products, services and information that meet or exceed customer requirements and expectations every time.”

This product guide is intended to provide technical data to deal with most applications. For severe applications not adequately covered here, please contact the factory for assistance.

Table of Contents

21 Series – Thermowells	1
22 Series – Protection Tubes.....	11
23 Series – Sample Probes.....	15
FC Series – Flange to Compression Connectors	18
Offer of Sale	19



⚠ WARNING – USER RESPONSIBILITY

FAILURE OR IMPROPER SELECTION OR IMPROPER USE OF THE PRODUCTS DESCRIBED HEREIN OR RELATED ITEMS CAN CAUSE DEATH, PERSONAL INJURY AND PROPERTY DAMAGE.

This document and other information from Parker-Hannifin Corporation, its subsidiaries and authorized distributors provide product or system options for further investigation by users having technical expertise.

The user, through its own analysis and testing, is solely responsible for making the final selection of the system and components and assuring that all performance, endurance, maintenance, safety and warning requirements of the application are met. The user must analyze all aspects of the application, follow applicable industry standards, and follow the information concerning the product in the current product catalog and in any other materials provided from Parker or its subsidiaries or authorized distributors.

To the extent that Parker or its subsidiaries or authorized distributors provide component or system options based upon data or specifications provided by the user, the user is responsible for determining that such data and specifications are suitable and sufficient for all applications and reasonably foreseeable uses of the components or systems.

Offer of Sale

The items described in this document are hereby offered for sale by Parker-Hannifin Corporation, its subsidiaries or its authorized distributors. This offer and its acceptance are governed by the provisions stated in the detailed "Offer of Sale" elsewhere in this document or available at www.parker.com/ipdus.

© Copyright 2009 Parker Hannifin Corporation. All Rights Reserved.

21 Series – Thermowells

Specifications

Materials

Parker Texas Thermowell thermowells are available in virtually any material to fit your application. Contact the factory regarding availability of materials not listed in the “Ordering Information” guide on pages 4 and 5.

Strength

The strength of a thermowell depends on several parameters that relate thermowell construction to the installation environment. For most industrial applications, standard Parker Texas Thermowell thermowells provide the necessary strength if the material, style, and length are correctly specified for the application parameters: fluid type, temperature, pressure, and fluid velocity. It is important to note that most thermowell failures are caused by vibration that is induced by fluid flow.

In addition to providing this selection guide, Parker Texas Thermowell offers assistance in correctly selecting thermowells, given the application parameters. This service is available for a nominal charge. Contact the factory for more information.

Construction

All 21 Series thermowell bodies are machined from bar stock. Flange mounts are welded to the thermowell body. The serial number and material are etched on each thermowell. Additional tagging for specific customer requirements is available.

Manufacturing Standards

Bar Stock

Mill Standard +0.000" to -1/32"

Shank O.D.

±0.010"

“U” Dimension

±0.050"

Overall Length

±0.050"

Tip Thickness

1/4" ±0.050" (unless otherwise specified)

Shank Surface Finish

Polished to 16 RMS

Bore

±0.003"

Thermowell Terminology

Process Connection: External means to connect thermowell to process system. Wells can be threaded, bolted (to matching flange), clamped, or welded in place.

Instrument Connection: Internal threads to connect temperature instrument to thermowell.

“U” Dimension: Length of thermowell immersed into process system. Measured from the base of the process connection to the end tip of the well.

“T” Dimension: Also called “lag length” or “lagging extension.” Extends length between the instrument and process connections to accommodate vessel or piping insulation.

“A” Dimension: Instrument insertion length into thermowell. Equal to bore length.

“D” Dimension: Also called “tip diameter.” Diameter of thermowell shank at the end tip of the thermowell. This dimension may vary with process connection, shank design, or bore diameter.

“Q” Dimension: Also called “root diameter.” Diameter of thermowell shank below the process connection. This dimension may vary with process connection, shank design, or bore diameter.

Bore Diameter: Dimension of internal bore to match the diameter of the instrument inserted into the thermowell.

Stepped Shank: Also called “reduced tip.” The shank O.D. is reduced over the last 2-1/2" of the “U” dimension from the standard root diameter to 1/2" O.D.

Straight Shank: Shank O.D. is the same from the root diameter (“Q” dimension) to the tip diameter (“D” dimension). The straight shank is generally used with a 0.385" or larger bore diameter, but is also available with a 0.260" bore.

Tapered Shank: Shank O.D. is gradually reduced from the root diameter (“Q” dimension) to the tip diameter (“D” dimension). The tapered shank is recommended for heavy duty applications characterized by high vibration, pressure, temperature, and/or velocity.

Selection Considerations

Immersion Length (“U” Dimension)

For best temperature measurement accuracy, the “U” dimension should be long enough to permit the entire temperature-sensitive part of the measuring instrument to project into the medium being measured.

Liquid temperature measurement: A properly designed thermowell will extend into the fluid an amount equal to the length of the temperature-sensitive zone plus one inch or greater.

Gas temperature measurement: A properly designed thermowell will extend into the fluid an amount equal to the length of the temperature-sensitive zone plus three inches or greater.

The temperature-sensitive zone for thermocouples and thermistors is short (right at the tip of the device), enabling measurement accuracy with limited immersion into the process fluid.

Bi-metal thermometers, resistance temperature detectors (RTDs), and liquid-in-glass thermometers have bulbs with temperature-sensitive zones between one and two inches long.

Filled-system thermometer bulbs may have temperature-sensitive zones from one to several inches in length.

Bore Diameter

While Parker Texas Thermowell offers thermowells with bore diameters up to 1.0.", the most common are as follows:

0.260" bore:

- Bi-metal Thermometers (1/4" stem)
- Thermocouples (1/4" sheath)
- RTDs (1/4" sheath)
- Liquid-in-glass Test Thermometers (unarmored)
- Other elements having 0.252" maximum diameter

0.385" bore:

- Bi-metal Thermometers (3/8" stem)
- Thermocouples (8 and 14 gage)
- Liquid-in-glass Test Thermometers (armored)
- Other elements having 0.377" maximum diameter

Shank Style

Tapered shank wells provide greater stiffness for the same sensitivity. The higher strength to weight ratio gives these wells higher natural frequency than for equivalent straight shank wells, thus permitting operation at higher fluid velocities.

Velocity Ratings

In most cases, thermowell failures are not due to the effects of pressure and temperature. The calculations necessary to provide adequate strength under given conditions are familiar enough to permit proper choice of wall thickness and material.

Less familiar are the vibrational effects to which thermowells are subjected. Fluid flowing past the well forms a turbulent wake (the Von Karman Trail), which has a definite frequency based on the diameter of the well and the velocity of the fluid. The thermowell must have sufficient stiffness so that the wake frequency will never equal the natural frequency of the thermowell itself. If the

natural frequency of the well were to coincide with the wake frequency, the well would vibrate to destruction and break off.

Table 1 provides recommended maximum velocity ratings for common well length and material combinations. To reduce the complexity of presenting this information, the ratings given are based on operating temperatures of 1000°F for carbon steel, 304 SST, and 316 SST wells. Ratings for brass wells are based on 350°F service. Ratings for Monel wells are based on 900°F service. Slightly higher velocity is possible at lower temperatures.

The velocity ratings provided are extremely conservative and intended primarily as a guide. Wells are safe from vibrational destruction if the resonant frequency is well below the wake frequency, or if the fluid velocity is constantly fluctuating through the critical velocity point. Nevertheless, if the installation is not hampered by a sufficiently stiff well, it is recommended that the values given not be exceeded.

Table 1. Maximum Fluid Velocity Ratings (ft/sec)

Shank Style	Root Dia. "Q" Dim.	Material	Process Fluid	Immersion Length – "U" Dimension									
				2-1/2"	4-1/2"	7-1/2"	10-1/2"	13-1/2"	16-1/2"	19-1/2"	22-1/2"		
Stepped	3/4"	Brass	Liquid	59.3	39.8	23.9	16.4	9.9	6.6	4.8	3.6		
			Gas	207	89.1	32.3							
		Carbon Steel	Liquid	106	71.2	42.7	22.8	13.8	9.3	6.7	4.9		
			Gas	290	123	44.9							
		304, 316 SST	Liquid	148	99.3	46.4	23.6	14.3	9.6	6.9	5.1		
			Gas	300	128								
		Monel	Liquid	118	79.8	40.6	20.7	12.4	8.3	6.1	4.5		
			Gas	261	112								
	7/8"	Brass	Liquid	59.3	47.6	37.0	18.8	11.4	7.6	5.5	4.1		
			Gas	207	102	28.0							
		Carbon Steel	Liquid	106	84.3	51.6	26.2	15.9	10.6	7.6	5.7		
			Gas	290	143	50.6							
		304, 316 SST	Liquid	148	117	53.5	27.2	16.5	11.0	7.9	5.9		
			Gas	300	148								
		Monel	Liquid	118	93.3	46.7	23.7	14.4	9.5	6.9	5.1		
			Gas	261	128								
Straight	Any	Brass	Liquid	145	80	48.0	27.6	16.7	11.1	8.0	6.0		
			Gas	290	150	54.1							
		Carbon Steel	Liquid	260	144	69.5	35.4	20.5	14.3	10.3	7.7		
			Gas	326	192								
		304, 316 SST	Liquid	360	199	71.9	36.6	21.2	14.8	10.7	8.0		
			Gas	349									
		Monel	Liquid	316	178	68.1	34.8	20.8	14.0	10.0	7.5		
			Gas	320	189								
		Tapered	Any	Carbon Steel	Liquid	270	150	90.3	45.6	27.8	18.5	13.2	9.8
					Gas	410	249						
304, 316 SST	Liquid			350	208	97.3	49.7	30.4	20.3	14.5	10.7		
	Gas			483	272								
Monel	Liquid			300	167	77.5	39.2	23.8	16.0	10.3	7.7		
	Gas			396	214								

Ordering Information

Example Model Number: 21A105F43A30ACC-D

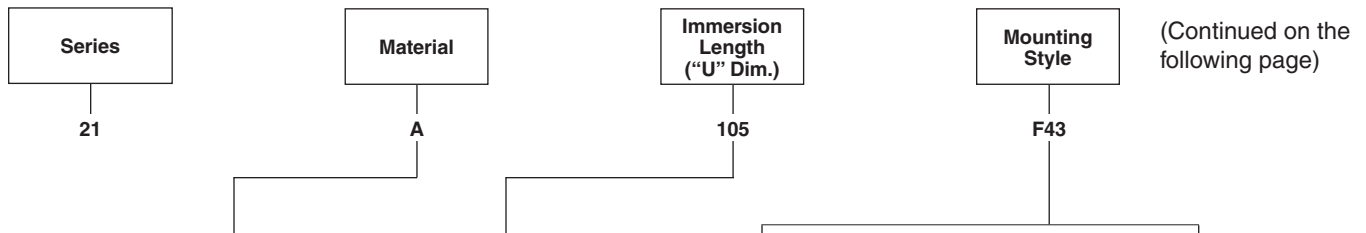

Material	Code
304 SS	A
310 SS	C
316 SS	D
347 SS	E
321 SS	F
Alloy 20	G
CS-1018	H
CS-A105	I
Hastelloy C	J
Hastelloy B	K
Alloy 800	L
Inconel 600	M
F-5	N
F-9	O
Monel 400	P
F-91	Q
F-11	R
F-22	S
Nickel 200	T
Duplex 2205	U
446 SS	V
Titanium	W
Brass	Y
Aluminum	Z
Other (please specify)	X

Length ("U") (in inches)	Code
1.6	016
2.0	020
2.5	025
3.0	030
3.5	035
4.0	040
4.5	045
5.0	050
5.5	055
6.0	060
6.5	065
7.0	070
7.5	075
8.0	080
8.5	085
9.0	090
9.5	095
10.0	100
10.5	105
11.0	110
11.5	115
12.0	120
...	...
15.0	150
...	...
17.5	175
...	...
20.0	200
...	...
30.0	300
...	...
45.0	450
etc...	etc...
Other	XXX

Mount Style		Shank Style		Process Connection	
Style	Code	Style	Code	Connection	Code
Threaded	T	Stepped	2	Threaded Only	
Flanged	F	Straight	3	1/2" NPT	1
Ring Joint	R	Tapered	4	3/4" NPT	2
Socket Weld	K			1" NPT	3
Weld-in	W			1-1/4" NPT	4
Van Stone	V			1-1/2" NPT	5
Sanitary	S			Flanged Only	
Flat Face	N			1" Class 150	1
				1-1/2" Class 150	2
				2" Class 150	3
				1" Class 300	4
				1-1/2" Class 300	5
				2" Class 300	6
				1" Class 600	7
				1-1/2" Class 600	8
				2" Class 600	9
				1" Class 900/1500	A
				1-1/2" Class 900/1500	B
				2" Class 900/1500	C
				1" Class 2500	D
				1-1/2" Class 2500	E
				2" Class 2500	F
				Socket Weld & Weld-in	
				3/4" pipe (1.050 O.D.)	1
				1" pipe (1.315 O.D.)	2
				1-1/4" pipe (1.660 O.D.)	3
				1-1/2" pipe (1.900 O.D.)	4
				1-1/2" Actual (1.500 O.D.)	5
				Van Stone Only	
				1"	1
				1-1/2"	2
				2"	3
				Sanitary Only	
				1-1/2" Tri-Clamp	1
				2" Tri-Clamp	2
				2-1/2" Tri-Clamp	3
				3" Tri-Clamp	4
				Other	
				(please specify)	X

(Continued from the previous page)

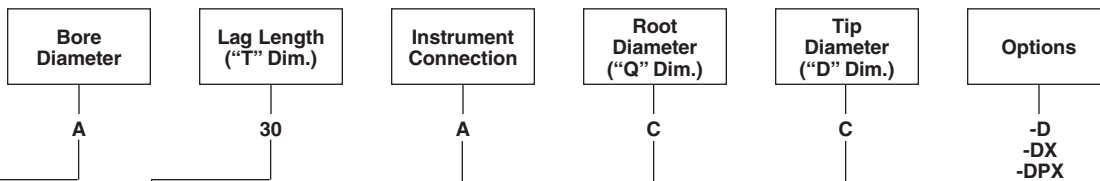

Bore	Code
0.260"	A
0.385"	B
0.437"	C
0.515"	D
0.656"	E
0.718"	F
Other (please specify)	X

Lag (in inches)	Code
0.0	00
0.5	05
1.0	10
1.5	15
2.0	20
2.5	25
3.0	30
3.5	35
4.0	40
4.5	45
5.0	50
5.5	55
6.0	60
6.5	65
7.0	70
7.5	75
8.0	80
8.5	85
9.0	90
9.5	95
Other (please specify)	XX

Thread	Code
1/4" NPT	C
1/2" NPT	A
3/4" NPT	D
1" NPT	F
1/4" NPSM	H
1/2" NPSM	B
3/4" NPSM	E
1" NPSM	G
1/4" CMP*	I
3/8" CMP*	J
1/2" CMP*	K
Other (please specify)	X

*CMP (compression)

Root (in inches)	Code
0.375	A
0.400	B
0.500	C
0.562	D
0.625	E
0.680	F
0.735	G
0.750	H
0.766	J
0.781	K
0.860	L
0.875	M
0.900	N
1.000	P
1.050	Q
1.063	R
1.125	S
1.250	T
1.315	U
1.375	V
1.500	W
1.625	Y
1.900	Z
Other	X

Tip (in inches)	Code
0.375	A
0.400	B
0.500	C
0.562	D
0.625	E
0.680	F
0.735	G
0.750	H
0.766	J
0.781	K
0.860	L
0.875	M
0.900	N
1.000	P
1.050	Q
1.063	R
1.125	S
1.250	T
1.315	U
1.375	V
1.500	W
1.625	Y
1.900	Z
Other	X

* Thermowells with a .500" or less stem diameter and a "U" diameter longer than 4.5" should be avoided. They should be replaced with a larger diameter and a stepped tip to maintain rigidity of well.

Special Docs Available Upon Request
COC / MTR / COO / CRN / NACE

Option	Code
Stainless Plug and Chain	A
Brass Plug and Chain	B
Chrome Plating	C
Dye Penetration Testing	D
External Hydro Pressure Test	E
Full Penetration Weld	F
Internal Hydro Pressure Test	I
Special Markings	M
Special Head Lengths and Diameter	N
Oxygen Cleaning	O
Positive Material ID (PMI)	P

Option	Code
Special Surface Finish	Q
Electropolishing	R
Stellite Overlay	S
Teflon Coating	T
Velocity Collar	V
Wake Frequency Calculation (Data Sheet Required)	W
X-ray of Weldment	X
Tantalum Sheath	Y
Titanium Sheath	Z

Figure 1. Threaded Thermowells

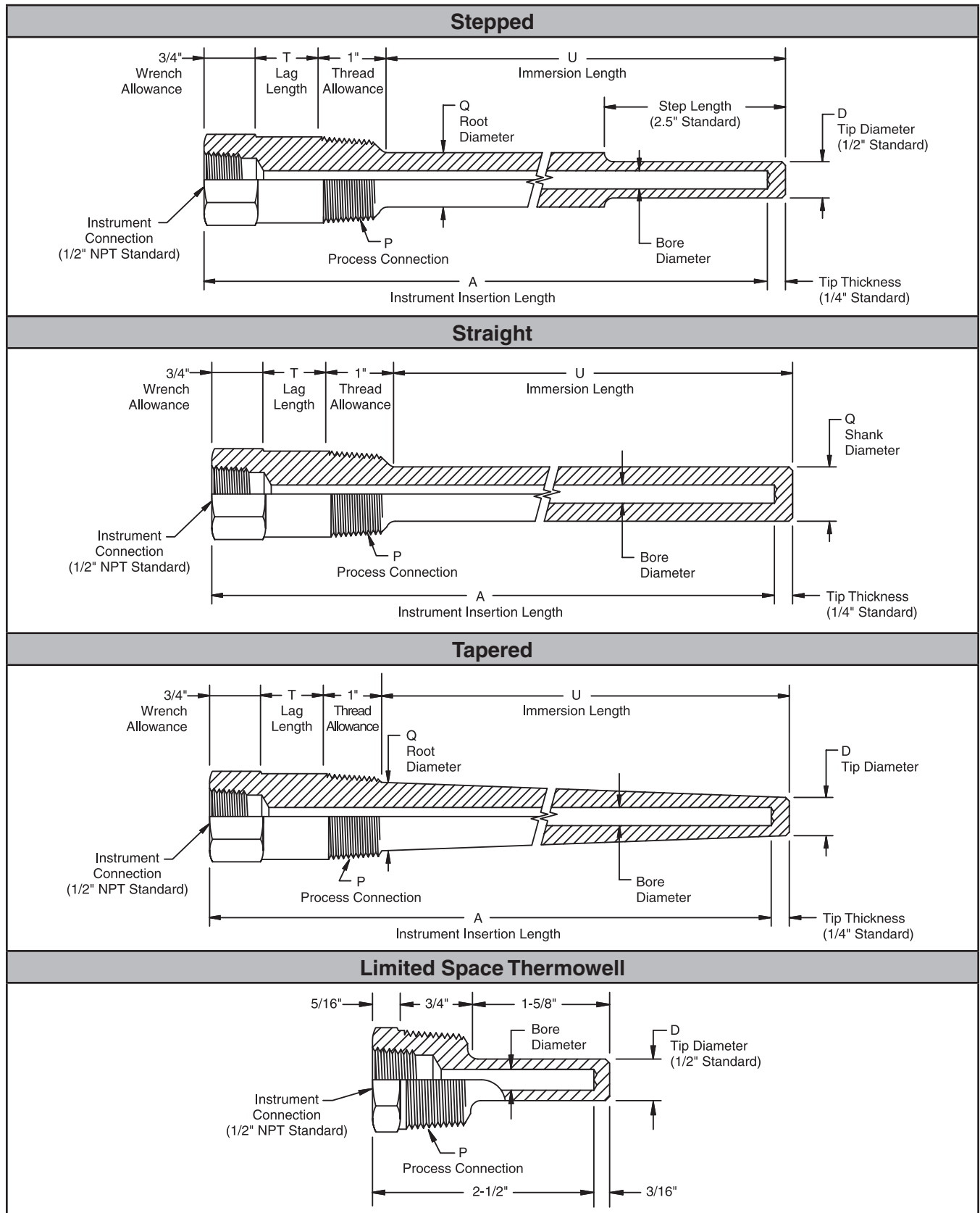

Figure 2. Flanged Thermowells

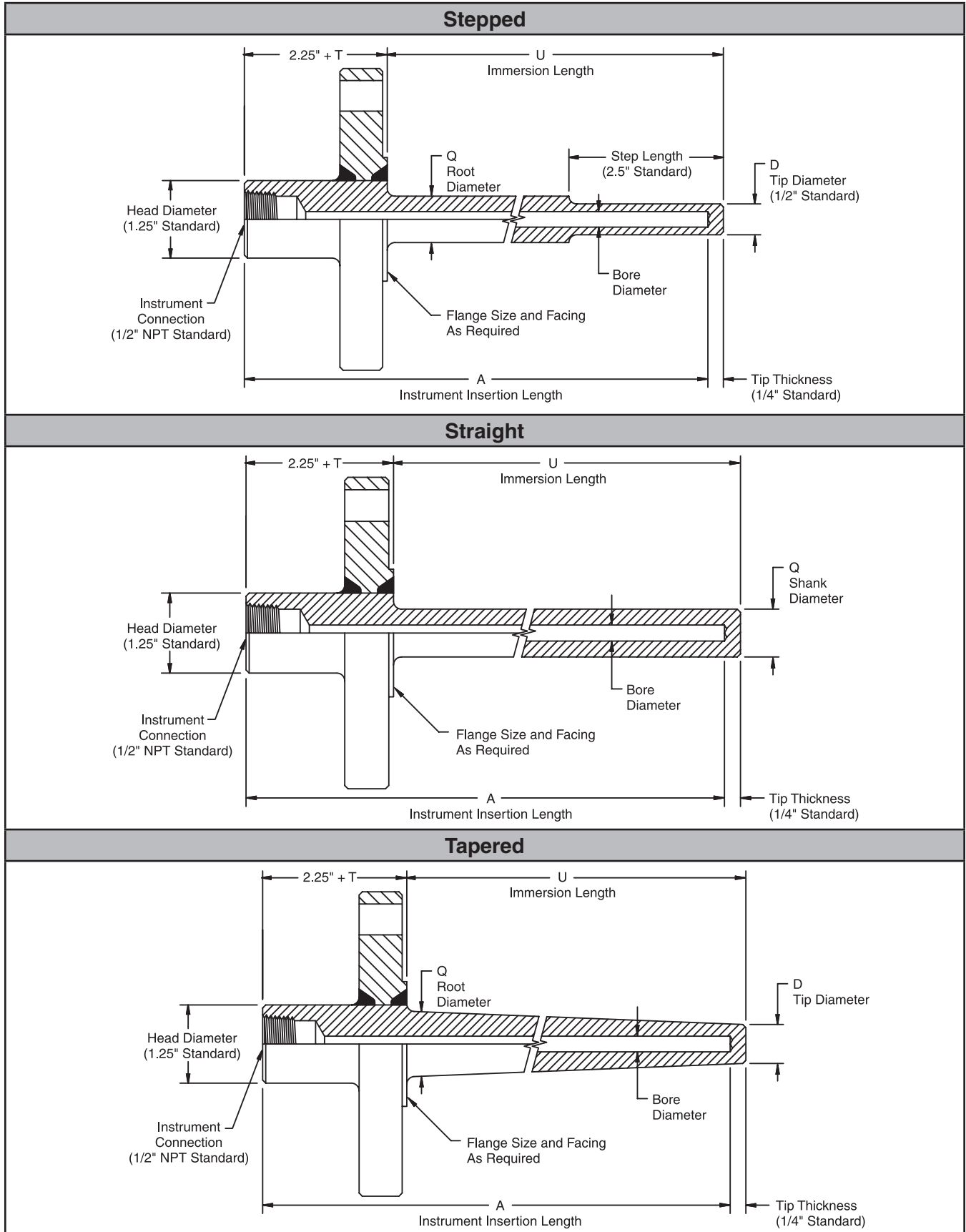

Figure 3. Van Stone Thermowells

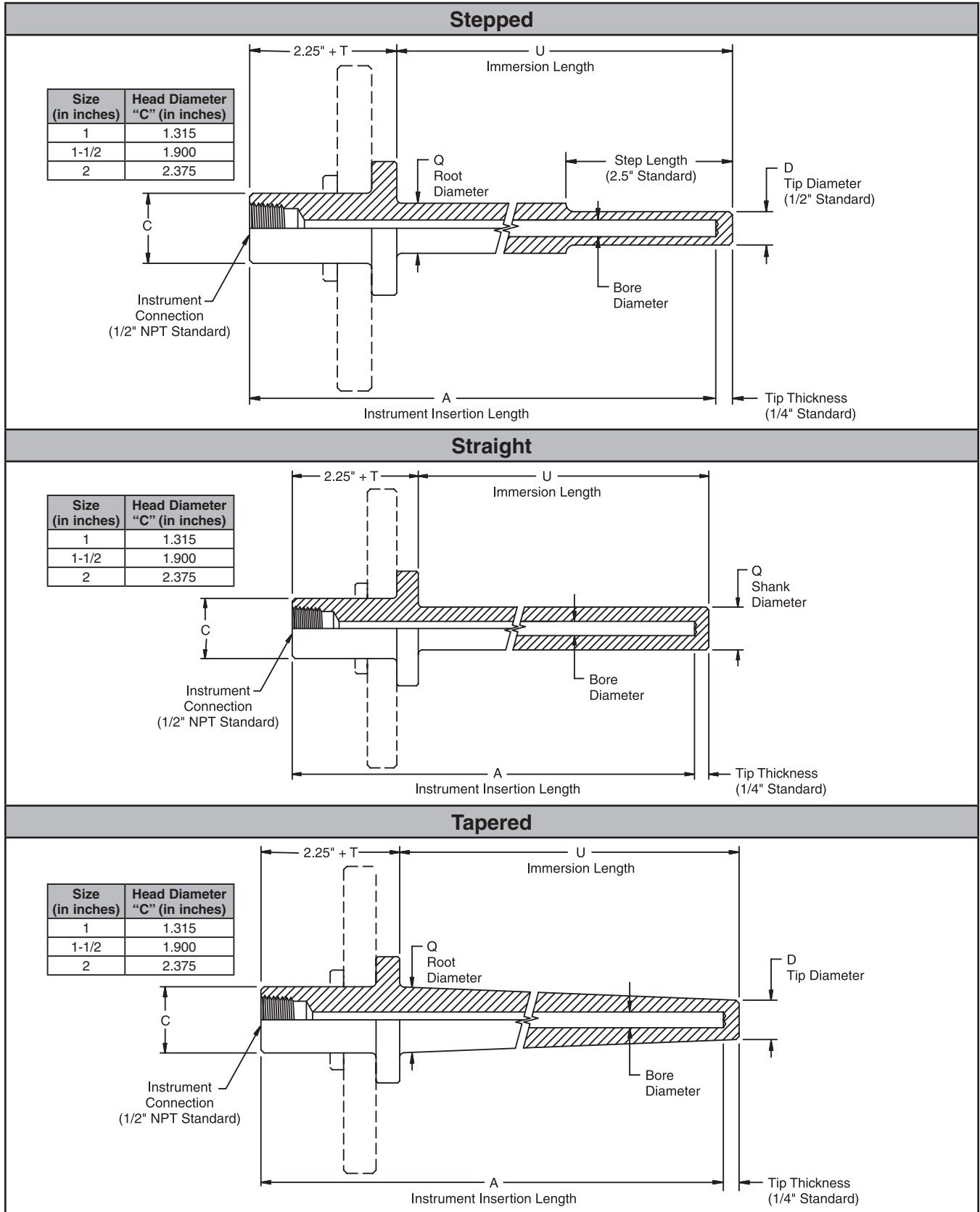

Figure 4. Socket Weld Thermowells

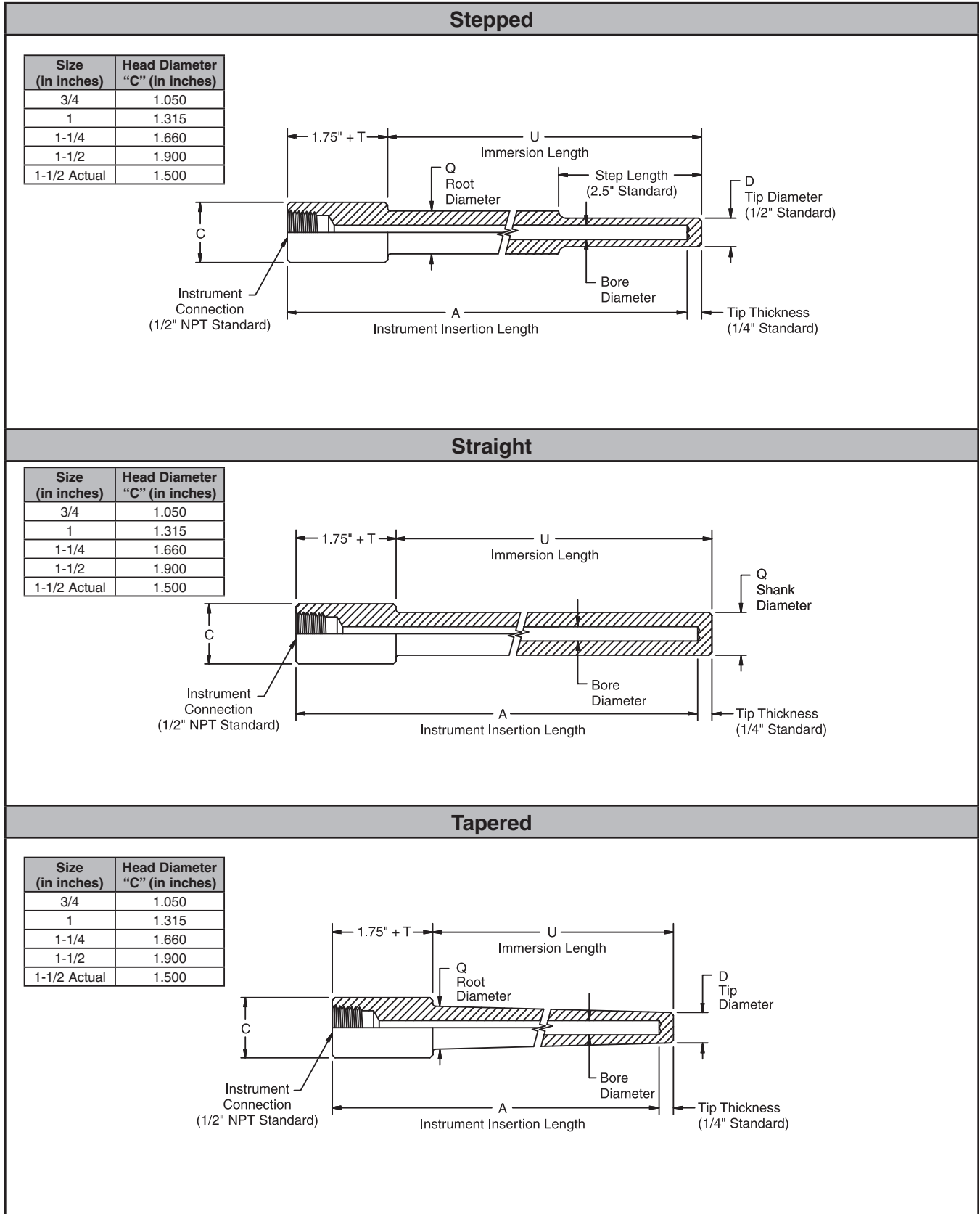

Figure 5. Sanitary Thermowells

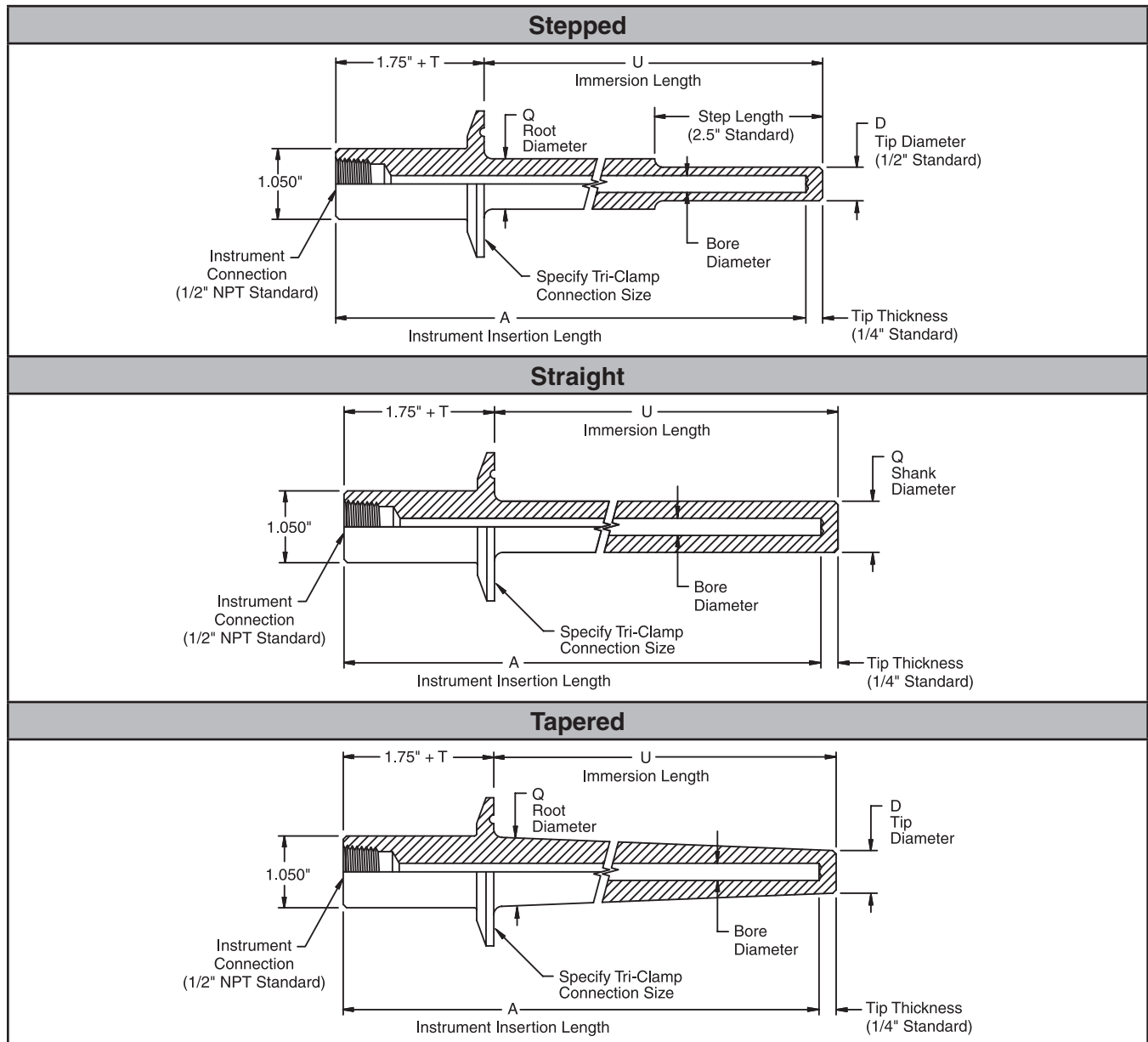
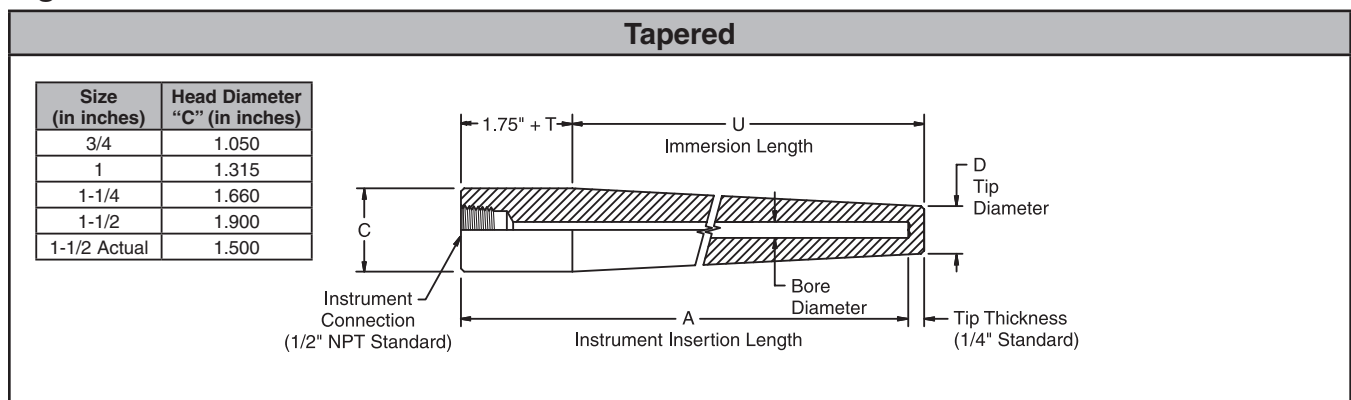

Figure 6. Weld-In Thermowells



22 Series – Protection Tubes

Manufacturing Standards

Material

In compliance with ASTM specifications or other applicable national standard (i.e., ASME, AWS, etc.)

Process Connection

Flange: In compliance with ANSI B16.5 prior to fabrication

Bushing: Welded in place

Welded: Bare tube

Instrument Connection

Male pipe thread in compliance with ANSI B1.20.1-92

“U” Dimension

±0.50" for immersion lengths <60"

±0.75" for immersion lengths 60" to 96"

±1.00" for immersion lengths >96"

Tip Thickness

1/4" ±0.050 (unless otherwise specified)

Welding

Flange to Base Metal:

per Parker Texas Thermowell Dwg. TX-A1

Bushing to Base Metal:

Fillet weld

Barstock for Closed-end:

per Parker Texas Thermowell dwg no. TX-FP-TIP⁽¹⁾

Pipe Cap for Closed-end:

per Parker Texas Thermowell dwg no. TX-B⁽¹⁾

(1) Full penetration weld locations are subject to minor distortion and internal filler metal slag.

Terminology

Process Connection: External means to connect protection tube to process system. Tubes can be threaded, bolted (to matching flange), or welded in place.

Instrument Connection: Means to connect temperature instrument to protection tube. Typically male pipe threaded.

“U” Dimension: Length of protection tube immersed into process system. Measured from the base of the process connection to the end tip of the tube.

“H” Dimension: Also called “head length.” Measured from the base of the process connection to the face of the instrument connection.

“A” Dimension: Instrument insertion length into protection tube.

Ordering Information

Example Model Number: 22A240E09A30A-MP

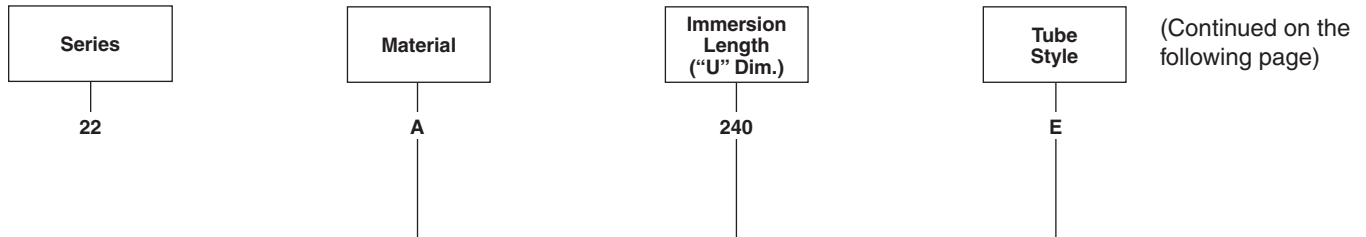

Material	Code
304 SS	A
310 SS	C
316 SS	D
321 SS	F
Alloy 20	G
CS-1018	H
CS-A105	I
Hastelloy C	J
Hastelloy B	K
Inconel 600	M
Monel	P
Nickel 200	T
446SS	V
Titanium	W
Brass	Y
Other (please specify)	X

Length ("U") (in inches)	Code
12	120
15	150
18	180
21	210
24	240
27	270
30	300
32	320
34	340
36	360
38	380
40	400
42	420
44	440
46	460
48	480
50	500
52	520
54	540
56	560
58	580
60	600
62	620
64	640
66	660
68	680
70	700
72	720
74	740
76	760
78	780
80	800
82	820
84	840
86	860
88	880
90	900
92	920
94	940
96	960
98	980
Other (please specify)	XXX

Tube Style	Size	Schedule	Code
Drilled Barstock	1/2" O.D.	–	A
	5/8" O.D.	–	B
	3/4" O.D.	–	C
	7/8" O.D.	–	D
	1" O.D.	–	E
	1-1/8" O.D.	–	F
	1-1/4" O.D.	–	G
Pipe	1/4"	40	H
		80	J
		160	K
		XX Heavy	L
	1/2"	40	M
		80	N
		160	P
		XX Heavy	Q
	3/4"	40	R
		80	T
		160	U
		XX Heavy	V
1"	40	W	
	80	X	
	160	Y	
	XX Heavy	Z	

22 Series – Protection Tubes

(Continued from the previous page)

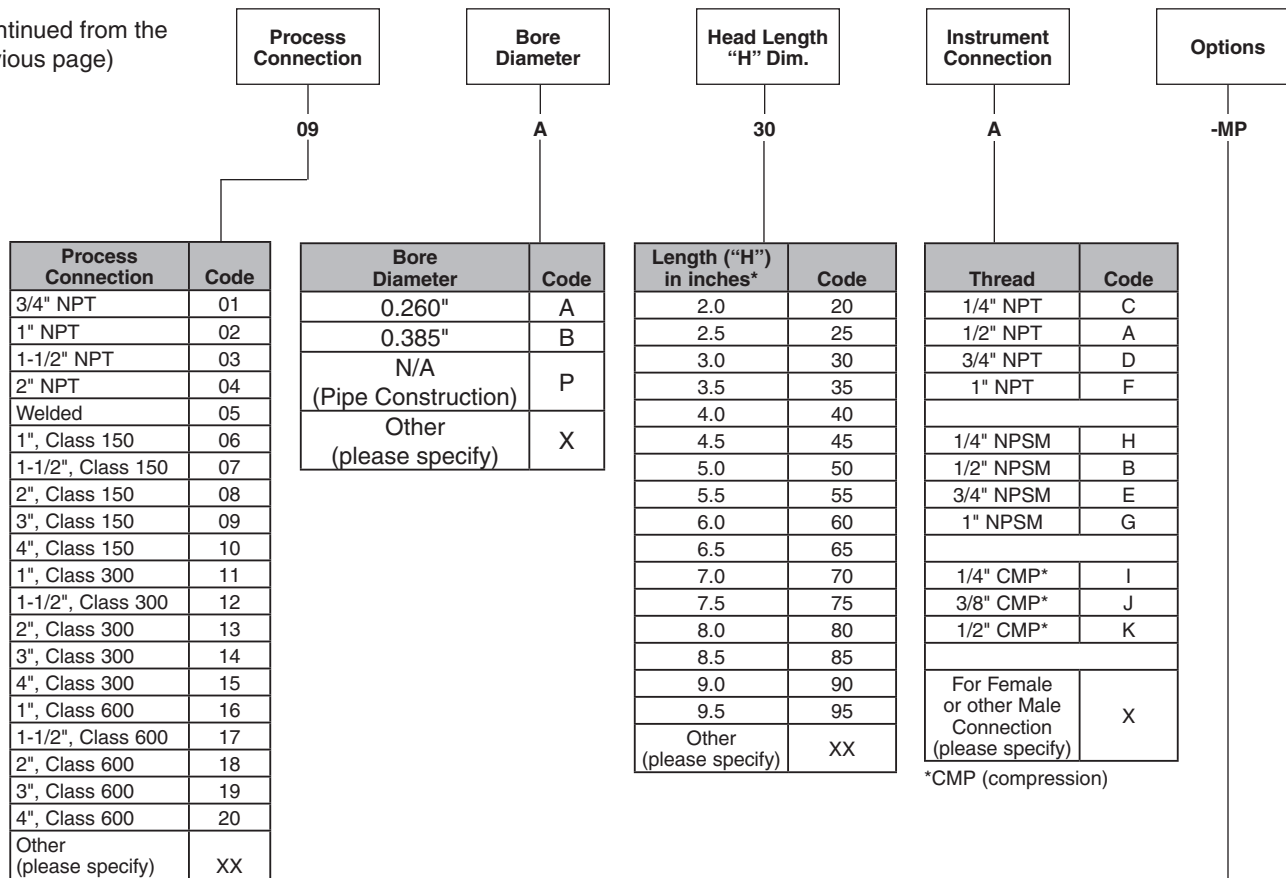

Process Connection	Code
3/4" NPT	01
1" NPT	02
1-1/2" NPT	03
2" NPT	04
Welded	05
1", Class 150	06
1-1/2", Class 150	07
2", Class 150	08
3", Class 150	09
4", Class 150	10
1", Class 300	11
1-1/2", Class 300	12
2", Class 300	13
3", Class 300	14
4", Class 300	15
1", Class 600	16
1-1/2", Class 600	17
2", Class 600	18
3", Class 600	19
4", Class 600	20
Other (please specify)	XX

Bore Diameter	Code
0.260"	A
0.385"	B
N/A (Pipe Construction)	P
Other (please specify)	X

Length ("H") in inches*	Code
2.0	20
2.5	25
3.0	30
3.5	35
4.0	40
4.5	45
5.0	50
5.5	55
6.0	60
6.5	65
7.0	70
7.5	75
8.0	80
8.5	85
9.0	90
9.5	95
Other (please specify)	XX

Thread	Code
1/4" NPT	C
1/2" NPT	A
3/4" NPT	D
1" NPT	F
1/4" NPSM	H
1/2" NPSM	B
3/4" NPSM	E
1" NPSM	G
1/4" CMP*	I
3/8" CMP*	J
1/2" CMP*	K
For Female or other Male Connection (please specify)	X

*CMP (compression)

Option	Code
Stainless Plug and Chain	A
Brass Plug and Chain	B
Chrome Plating	C
Dye Penetration Testing	D
External Hydro Pressure Test	E
Full Penetration Weld	F
Internal Hydro Pressure Test	I
Special Markings	M
Special Head Lengths and Diameter	N
Oxygen Cleaning	O
Positive Material ID (PMI)	P

Option	Code
Special Surface Finish	Q
Electropolishing	R
Stellite Overlay	S
Teflon Coating	T
Velocity Collar	V
Wake Frequency Calculation (Data Sheet Required)	W
X-ray of Weldment	X
Tantalum Sheath	Y
Titanium Sheath	Z

Figure 7. Drilled Barstock Protection Tubes

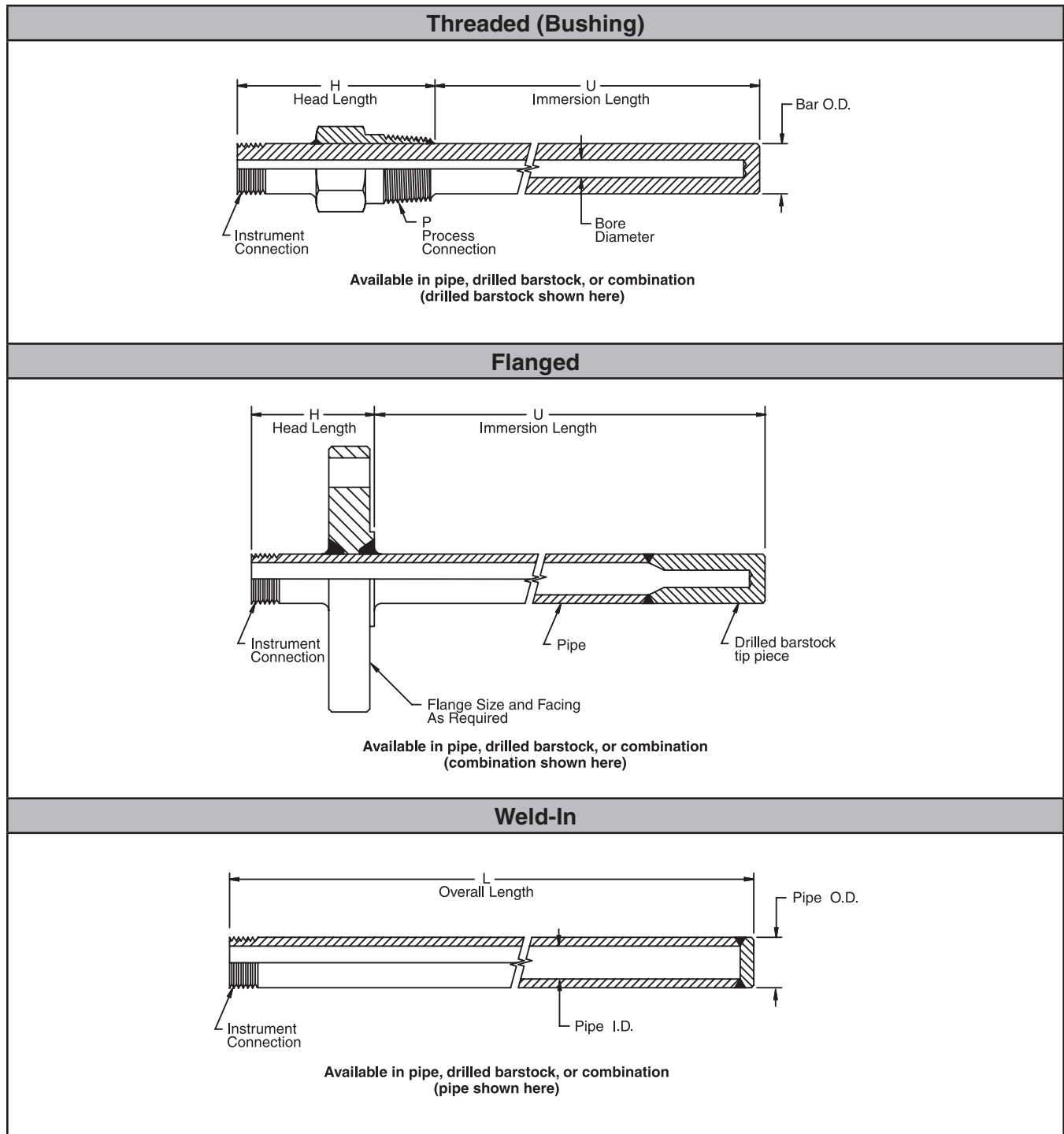

23 Series – Sample Probes

Manufacturing Standards

Bar Stock

Mill Standard +0.000" / -1/32"

Shank O.D.

±0.010"

“U” Dimension

±0.050"

Overall Length

±0.050"

Shank Surface Finish

Polished to 16 RMS

Bore

±0.003"

Figure 8. Sample Probes

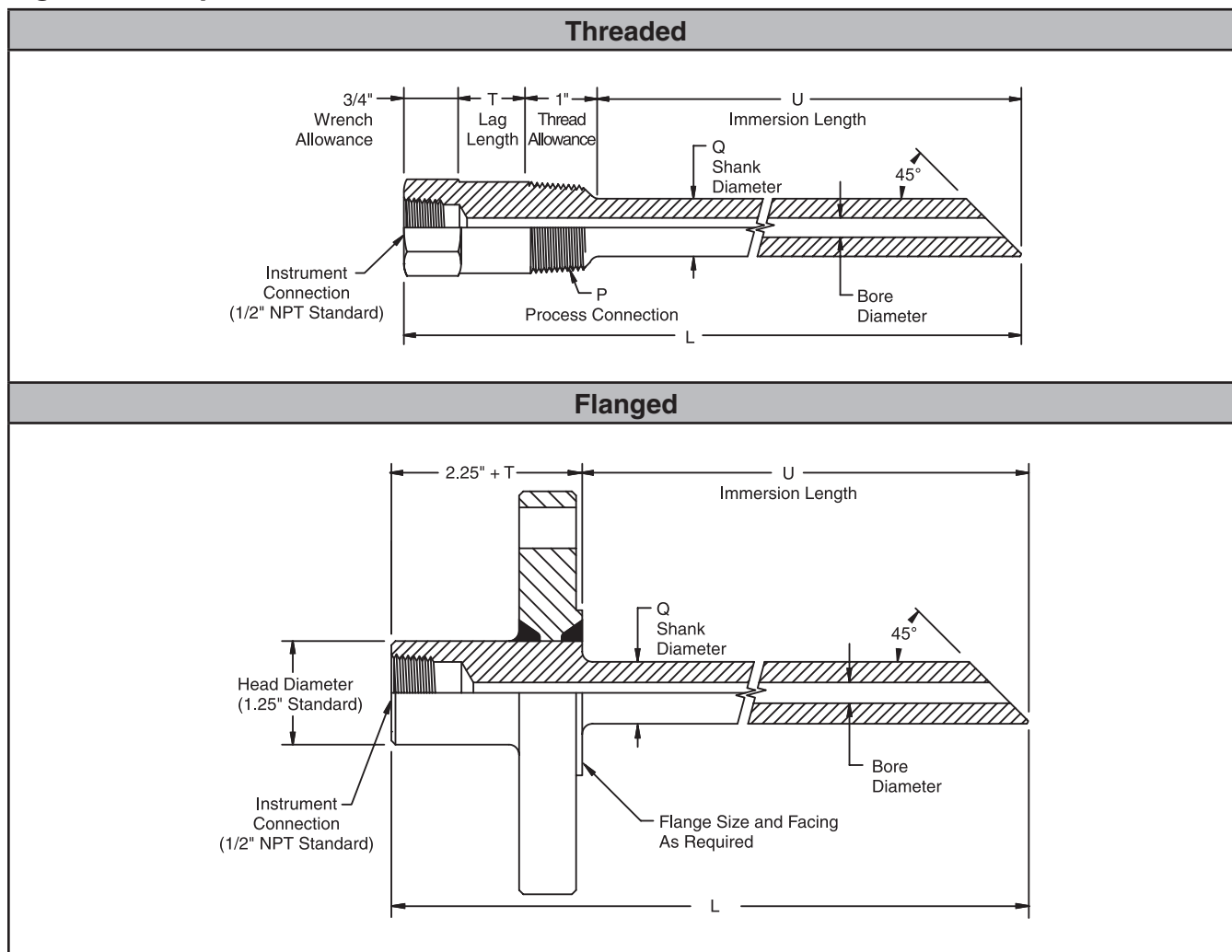

Ordering Information

Example Model Number: 23A070T21A30AH-MP

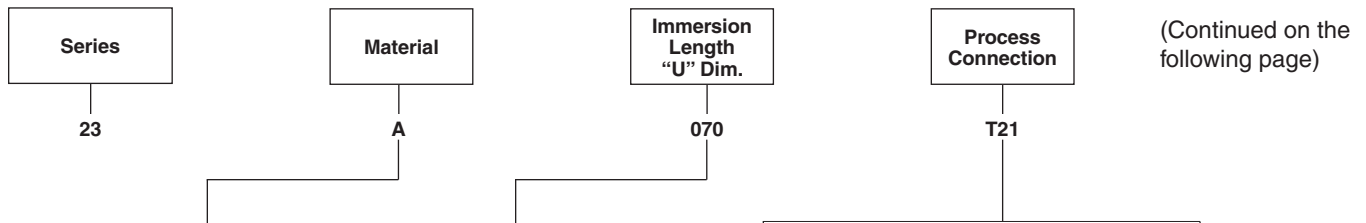

(Continued on the following page)

Material	Code
304 SS	A
310 SS	C
316 SS	D
347 SS	E
321 SS	F
Alloy 20	G
CS-1018	H
CS-A105	I
Hastelloy C	J
Hastelloy B	K
Alloy 800	L
Inconel 600	M
F-5	N
F-9	O
Monel 400	P
F-91	Q
F-11	R
F-22	S
Nickel 200	T
Duplex 2205	U
446 SS	V
Titanium	W
Brass	Y
Aluminum	Z
Other (please specify)	X

Length ("U") (in inches)	Code
1.6	016
2.0	020
2.5	025
3.0	030
3.5	035
4.0	040
4.5	045
5.0	050
5.5	055
6.0	060
6.5	065
7.0	070
7.5	075
8.0	080
8.5	085
9.0	090
9.5	095
10.0	100
10.5	105
11.0	110
11.5	115
12.0	120
...	...
15.0	150
...	...
17.5	175
...	...
20.0	200
...	...
30.0	300
...	...
45.0	450
etc...	etc...
Other	XXX

Mount Style		Shank Style	
Style	Code	Style	Code
Threaded	T	Straight	3
Flanged	F		
Ring Joint	R		
Socket Weld	K		
Weld-in	W		
Van Stone	V		
Sanitary	S		
Flat Face	N		

Process Connection		
Connection	Code	
Threaded Only		
1/2" NPT	1	
3/4" NPT	2	
1" NPT	3	
1-1/4" NPT	4	
1-1/2" NPT	5	

Flanged Only		
Connection	Code	
1" Class 150	1	
1-1/2" Class 150	2	
2" Class 150	3	
1" Class 300	4	
1-1/2" Class 300	5	
2" Class 300	6	
1" Class 600	7	
1-1/2" Class 600	8	
2" Class 600	9	
1" Class 900/1500	A	
1-1/2" Class 900/1500	B	
2" Class 900/1500	C	
1" Class 2500	D	
1-1/2" Class 2500	E	
2" Class 2500	F	

Socket Weld & Weld-in		
Connection	Code	
3/4" pipe (1.050 O.D.)	1	
1" pipe (1.315 O.D.)	2	
1-1/4" pipe (1.660 O.D.)	3	
1-1/2" pipe (1.900 O.D.)	4	
1-1/2" Actual (1.500 O.D.)	5	

Van Stone Only		
Connection	Code	
1"	1	
1-1/2"	2	
2"	3	

Sanitary Only		
Connection	Code	
1-1/2" Tri-Clamp	1	
2" Tri-Clamp	2	
2-1/2" Tri-Clamp	3	
3" Tri-Clamp	4	

Other		
Connection	Code	
(please specify)	X	

(Continued from the previous page)



A

30

A

H

-MP

Bore Diameter	Code
0.260"	A
0.385"	B
Other (please specify)	X

Length (in inches)	Code
0.0	00
0.5	05
1.0	10
1.5	15
2.0	20
2.5	25
3.0	30
3.5	35
4.0	40
4.5	45
5.0	50
5.5	55
6.0	60
6.5	65
7.0	70
7.5	75
8.0	80
8.5	85
9.0	90
9.5	95
Other (please specify)	XX

Thread	Code
1/4" NPT	C
1/2" NPT	A
3/4" NPT	D
1" NPT	F
1/4" NPSM	H
1/2" NPSM	B
3/4" NPSM	E
1" NPSM	G
1/4" CMP*	I
3/8" CMP*	J
1/2" CMP*	K
Other (please specify)	X

*CMP (compression)

Diameter ("D" in inches)	Code
0.375	A
0.400	B
0.500	C
0.562	D
0.625	E
0.680	F
0.735	G
0.750	H
0.766	J
0.781	K
0.860	L
0.875	M
0.900	N
1.000	P
1.050	Q
1.063	R
1.125	S
1.250	T
1.315	U
1.375	V
1.500	W
1.625	Y
1.900	Z
Other (please specify)	X

Option	Code
Stainless Plug and Chain	A
Brass Plug and Chain	B
Chrome Plating	C
Dye Penetration Testing	D
External Hydro Pressure Test	E
Full Penetration Weld	F
Internal Hydro Pressure Test	I
Special Markings	M
Special Head Lengths and Diameter	N
Oxygen Cleaning	O
Positive Material ID (PMI)	P

Option	Code
Special Surface Finish	Q
Electropolishing	R
Stellite Overlay	S
Teflon Coating	T
Velocity Collar	V
Wake Frequency Calculation (Data Sheet Required)	W
X-ray of Weldment	X
Tantalum Sheath	Y
Titanium Sheath	Z

FC Series – Flange to Compression Connectors

One piece integral connectors allow the user to convert standard piping flanges to an instrumentation compression fitting with minimal cost and added safety. This system eliminates the need for additional connections while also eliminating the need for welding or pipe threads.



Product Features and Specifications:

- Full heat code traceability.
- Integrally machined body, no welding.
- Flanges to ANSI B16.5.
- NACE MR 0175 compliance available on request.
- Raised face spiral and ring joint type sealing.
- Standard stainless steel body (316).
- 1/2" to 2" nominal flanges.
- Standard A-LOK® and CPI™ arrangements 1/4" to 1-1/2" O.D.
- Other connections and materials possible. Contact factory for availability.

Ordering Information

Example Model Numbers:

1 - CPI™ FC K 4 Z 8 T 1500 U
 2 - A-LOK® FC B 8 A 16 F 600 U

Product Code	Material	Connection Size	Type	Flange Size	Face Style	Class	Manufactured in US
Code	Material	Code	Type	Code	Face Style	Code	Class
B	Stainless Steel 316 (Standard)	4	A	8	F	150	150 lb.
A	Carbon Steel A105	6	Z	12	T	300	300 lb.
D	Monel M400	8		16		600	600 lb.
E	Duplex UNS 31803	12		24		900	900 lb.
F	Super Duplex UNS S.32750	14		32		1500	1500 lb.
G	Hastelloy C-276	16				2500	2500 lb.
K	6Mo	20					
L	825	24					
M	Inconel 625						

Code	Tube O.D.
4	1/4"
6	3/8"
8	1/2"
12	3/4"
14	7/8"
16	1"
20	1-1/4"
24	1-1/2"

Code	Flange Size
8	1/2"
12	3/4"
16	1"
24	1-1/2"
32	2"

Size Limitations	
Nominal Flange	Largest Std. A-LOK®/CPI™
1/2"	1/2"
3/4"	3/4"
1"	1"
1-1/2"	1-1/4"
2"	1-1/2"

Example 1: FCK4Z8T1500U is a 6Mo, 1/4" O.D. CPI™ tube connection, 1/2" pipe flange, ring type joint, class 1500 flange to compression connector manufactured in the US.

Example 2: FCB8A16F600U is a stainless steel, 1/2" O.D. A-LOK® tube connection, 1" pipe flange, raised face, class 600 flange to compression connector manufactured in the US.

Offer of Sale

The items described in this document and other documents and descriptions provided by Parker Hannifin Corporation, its subsidiaries and its authorized distributors ("Seller") are hereby offered for sale at prices to be established by Seller. This offer and its acceptance by any customer ("Buyer") shall be governed by all of the following Terms and Conditions. Buyer's order for any item described in its document, when communicated to Seller verbally, or in writing, shall constitute acceptance of this offer. All goods or work described will be referred to as "Products".

1. Terms and Conditions. Seller's willingness to offer Products, or accept an order for Products, to or from Buyer is expressly conditioned on Buyer's assent to these Terms and Conditions and to the terms and conditions found on-line at www.parker.com/saleterms/. Seller objects to any contrary or additional term or condition of Buyer's order or any other document issued by Buyer.

2. Price Adjustments; Payments. Prices stated on the reverse side or preceding pages of this document are valid for 30 days. After 30 days, Seller may change prices to reflect any increase in its costs resulting from state, federal or local legislation, price increases from its suppliers, or any change in the rate, charge, or classification of any carrier. The prices stated on the reverse or preceding pages of this document do not include any sales, use, or other taxes unless so stated specifically. Unless otherwise specified by Seller, all prices are F.O.B. Seller's facility, and payment is due 30 days from the date of invoice. After 30 days, Buyer shall pay interest on any unpaid invoices at the rate of 1.5% per month or the maximum allowable rate under applicable law.

3. Delivery Dates; Title and Risk; Shipment. All delivery dates are approximate and Seller shall not be responsible for any damages resulting from any delay. Regardless of the manner of shipment, title to any products and risk of loss or damage shall pass to Buyer upon tender to the carrier at Seller's facility (i.e., when it's on the truck, it's yours). Unless otherwise stated, Seller may exercise its judgment in choosing the carrier and means of delivery. No deferment of shipment at Buyers' request beyond the respective dates indicated will be made except on terms that will indemnify, defend and hold Seller harmless against all loss and additional expense. Buyer shall be responsible for any additional shipping charges incurred by Seller due to Buyer's changes in shipping, product specifications or in accordance with Section 13, herein.

4. Warranty. Seller warrants that the Products sold hereunder shall be free from defects in material or workmanship for a period of twelve months from the date of delivery to Buyer or 2,000 hours of normal use, whichever occurs first. This warranty is made only to Buyer and does not extend to anyone to whom Products are sold after purchased from Seller. The prices charged for Seller's products are based upon the exclusive limited warranty stated above, and upon the following disclaimer: **DISCLAIMER OF WARRANTY: THIS WARRANTY COMPRISES THE SOLE AND ENTIRE WARRANTY PERTAINING TO PRODUCTS PROVIDED HEREUNDER. SELLER DISCLAIMS ALL OTHER WARRANTIES, EXPRESS AND IMPLIED, INCLUDING MERCHANTABILITY AND FITNESS FOR A PARTICULAR PURPOSE.**

5. Claims; Commencement of Actions. Buyer shall promptly inspect all Products upon delivery. No claims for shortages will be allowed unless reported to the Seller within 10 days of delivery. No other claims against Seller will

be allowed unless asserted in writing within 60 days after delivery or, in the case of an alleged breach of warranty, within 30 days after the date within the warranty period on which the defect is or should have been discovered by Buyer. Any action based upon breach of this agreement or upon any other claim arising out of this sale (other than an action by Seller for any amount due to Seller from Buyer) must be commenced within thirteen months from the date of tender of delivery by Seller or, for a cause of action based upon an alleged breach of warranty, within thirteen months from the date within the warranty period on which the defect is or should have been discovered by Buyer.

6. LIMITATION OF LIABILITY. UPON NOTIFICATION, SELLER WILL, AT ITS OPTION, REPAIR OR REPLACE A DEFECTIVE PRODUCT, OR REFUND THE PURCHASE PRICE. IN NO EVENT SHALL SELLER BE LIABLE TO BUYER FOR ANY SPECIAL, INDIRECT, INCIDENTAL OR CONSEQUENTIAL DAMAGES ARISING OUT OF, OR AS THE RESULT OF, THE SALE, DELIVERY, NON-DELIVERY, SERVICING, USE OR LOSS OF USE OF THE PRODUCTS OR ANY PART THEREOF, OR FOR ANY CHARGES OR EXPENSES OF ANY NATURE INCURRED WITHOUT SELLER'S WRITTEN CONSENT, EVEN IF SELLER HAS BEEN NEGLIGENT, WHETHER IN CONTRACT, TORT OR OTHER LEGAL THEORY. IN NO EVENT SHALL SELLER'S LIABILITY UNDER ANY CLAIM MADE BY BUYER EXCEED THE PURCHASE PRICE OF THE PRODUCTS.

7. Contingencies. Seller shall not be liable for any default or delay in performance if caused by circumstances beyond the reasonable control of Seller.

8. User Responsibility. The user, through its own analysis and testing, is solely responsible for making the final selection of the system and Product and assuring that all performance, endurance, maintenance, safety and warning requirements of the application are met. The user must analyze all aspects of the application and follow applicable industry standards and Product information. If Seller provides Product or system options, the user is responsible for determining that such data and specifications are suitable and sufficient for all applications and reasonably foreseeable uses of the Products or systems.

9. Loss to Buyer's Property. Any designs, tools, patterns, materials, drawings, confidential information or equipment furnished by Buyer or any other items which become Buyer's property, may be considered obsolete and may be destroyed by Seller after two consecutive years have elapsed without Buyer placing an order for the items which are manufactured using such property. Seller shall not be responsible for any loss or damage to such property while it is in Seller's possession or control.

10. Special Tooling. A tooling charge may be imposed for any special tooling, including without limitation, dies, fixtures, molds and patterns, acquired to manufacture Products.

Such special tooling shall be and remain Seller's property notwithstanding payment of any charges by Buyer. In no event will Buyer acquire any interest in apparatus belonging to Seller which is utilized in the manufacture of the Products, even if such apparatus has been specially converted or adapted for such manufacture and notwithstanding any charges paid by Buyer. Unless otherwise agreed, Seller shall have the right to alter, discard or otherwise dispose of any special tooling or other property in its sole discretion at any time.

11. Buyer's Obligation; Rights of Seller. To secure payment of all sums due or otherwise, Seller shall retain a security interest in the goods delivered and this agreement shall be deemed a Security Agreement under the Uniform Commercial Code. Buyer authorizes Seller as its attorney to execute and file on Buyer's behalf all documents Seller deems necessary to perfect its security interest. Seller shall have a security interest in, and lien upon, any property of Buyer in Seller's possession as security for the payment of any amounts owed to Seller by Buyer.

12. Improper use and Indemnity. Buyer shall indemnify, defend, and hold Seller harmless from any claim, liability, damages, lawsuits, and costs (including attorney fees), whether for personal injury, property damage, patent, trademark or copyright infringement or any other claim, brought by or incurred by Buyer, Buyer's employees, or any other person, arising out of: (a) improper selection, improper application or other misuse of Products purchased by Buyer from Seller; (b) any act or omission, negligent or otherwise, of Buyer; (c) Seller's use of patterns, plans, drawings, or specifications furnished by Buyer to manufacture Product; or (d) Buyer's failure to comply with these terms and conditions. Seller shall not indemnify Buyer under any circumstance except as otherwise provided.

13. Cancellations and Changes. Orders shall not be subject to cancellation or change by Buyer for any reason, except with Seller's written consent and upon terms that will indemnify, defend and hold Seller harmless against all direct, incidental and consequential loss or damage. Seller may change product features, specifications, designs and availability with notice to Buyer.

14. Limitation on Assignment. Buyer may not assign its rights or obligations under this agreement without the prior written consent of Seller.

15. Entire Agreement. This agreement contains the entire agreement between the Buyer and Seller and constitutes the final, complete and exclusive expression of the terms of the agreement. All prior or contemporaneous written or oral agreements or negotiations with respect to the subject matter are herein merged.

16. Waiver and Severability. Failure to enforce any provision of this agreement will not waive that provision nor will any such failure prejudice Seller's right to enforce that provision in the future. Invalidation of any provision of this agreement by legislation or other rule of law shall not invalidate any other provision herein. The remaining provisions of this agreement will remain in full force and effect.

17. Termination. This agreement may be terminated by Seller for any reason and at any time by giving Buyer thirty (30) days written notice of termination. In addition, Seller may

by written notice immediately terminate this agreement for the following: (a) Buyer commits a breach of any provision of this agreement (b) the appointment of a trustee, receiver or custodian for all or any part of Buyer's property (c) the filing of a petition for relief in bankruptcy of the other Party on its own behalf, or by a third party (d) an assignment for the benefit of creditors, or (e) the dissolution or liquidation of the Buyer.

18. Governing Law. This agreement and the sale and delivery of all Products hereunder shall be deemed to have taken place in and shall be governed and construed in accordance with the laws of the State of Ohio, as applicable to contracts executed and wholly performed therein and without regard to conflicts of laws principles. Buyer irrevocably agrees and consents to the exclusive jurisdiction and venue of the courts of Cuyahoga County, Ohio with respect to any dispute, controversy or claim arising out of or relating to this agreement. Disputes between the parties shall not be settled by arbitration unless, after a dispute has arisen, both parties expressly agree in writing to arbitrate the dispute.

19. Indemnity for Infringement of Intellectual Property Rights. Seller shall have no liability for infringement of any patents, trademarks, copyrights, trade dress, trade secrets or similar rights except as provided in this Section. Seller will defend and indemnify Buyer against allegations of infringement of U.S. patents, U.S. trademarks, copyrights, trade dress and trade secrets ("Intellectual Property Rights"). Seller will defend at its expense and will pay the cost of any settlement or damages awarded in an action brought against Buyer based on an allegation that a Product sold pursuant to this Agreement infringes the Intellectual Property Rights of a third party. Seller's obligation to defend and indemnify Buyer is contingent on Buyer notifying Seller within ten (10) days after Buyer becomes aware of such allegations of infringement, and Seller having sole control over the defense of any allegations or actions including all negotiations for settlement or compromise. If a Product is subject to a claim that it infringes the Intellectual Property Rights of a third party, Seller may, at its sole expense and option, procure for Buyer the right to continue using the Product, replace or modify the Product so as to make it noninfringing, or offer to accept return of the Product and return the purchase price less a reasonable allowance for depreciation. Notwithstanding the foregoing, Seller shall have no liability for claims of infringement based on information provided by Buyer, or directed to Products delivered hereunder for which the designs are specified in whole or part by Buyer, or infringements resulting from the modification, combination or use in a system of any Product sold hereunder. The foregoing provisions of this Section shall constitute Seller's sole and exclusive liability and Buyer's sole and exclusive remedy for infringement of Intellectual Property Rights.

20. Taxes. Unless otherwise indicated, all prices and charges are exclusive of excise, sales, use, property, occupational or like taxes which may be imposed by any taxing authority upon the manufacture, sale or delivery of Products.

21. Equal Opportunity Clause. For the performance of government contracts and where dollar value of the Products exceed \$10,000, the equal employment opportunity clauses in Executive Order 11246, VEVRAA, and 41 C.F.R. §§ 60-1.4(a), 60-741.5(a), and 60-250.4, are hereby incorporated.

Parker's Motion & Control Technologies

At Parker, we're guided by a relentless drive to help our customers become more productive and achieve higher levels of profitability by engineering the best systems for their requirements. It means looking at customer applications from many angles to find new ways to create value. Whatever the motion and control technology need, Parker has the experience, breadth of product and global reach to consistently deliver. No company knows more about motion and control technology than Parker. For further info call 1-800-C-Parker.



AEROSPACE

Key Markets

- Aircraft engines
- Business & general aviation
- Commercial transports
- Land-based weapons systems
- Military aircraft
- Missiles & launch vehicles
- Regional transports
- Unmanned aerial vehicles

Key Products

- Flight control systems & components
- Fluid conveyance systems
- Fluid metering delivery & atomization devices
- Fuel systems & components
- Hydraulic systems & components
- Inert nitrogen generating systems
- Pneumatic systems & components
- Wheels & brakes



CLIMATE CONTROL

Key Markets

- Agriculture
- Air conditioning
- Food, beverage & dairy
- Life sciences & medical
- Precision cooling
- Processing
- Transportation

Key Products

- CO₂ controls
- Electronic controllers
- Filter driers
- Hand shut-off valves
- Hose & fittings
- Pressure regulating valves
- Refrigerant distributors
- Safety relief valves
- Solenoid valves
- Thermostatic expansion valves

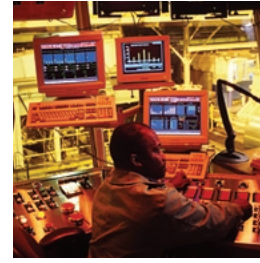

ELECTROMECHANICAL

Key Markets

- Aerospace
- Factory automation
- Life science & medical
- Machine tools
- Packaging machinery
- Paper machinery
- Plastics machinery & converting
- Primary metals
- Semiconductor & electronics
- Textile
- Wire & cable

Key Products

- AC/DC drives & systems
- Electric actuators, gantry robots & slides
- Electrohydraulic actuation systems
- Electromechanical actuation systems
- Human machine interface
- Linear motors
- Stepper motors, servo motors, drives & controls
- Structural extrusions



FILTRATION

Key Markets

- Food & beverage
- Industrial machinery
- Life sciences
- Marine
- Mobile equipment
- Oil & gas
- Power generation
- Process
- Transportation

Key Products

- Analytical gas generators
- Compressed air & gas filters
- Condition monitoring
- Engine air, fuel & oil filtration & systems
- Hydraulic, lubrication & coolant filters
- Process, chemical, water & microfiltration filters
- Nitrogen, hydrogen & zero air generators



FLUID & GAS HANDLING

Key Markets

- Aerospace
- Agriculture
- Bulk chemical handling
- Construction machinery
- Food & beverage
- Fuel & gas delivery
- Industrial machinery
- Mobile
- Oil & gas
- Transportation
- Welding

Key Products

- Brass fittings & valves
- Diagnostic equipment
- Fluid conveyance systems
- Industrial hose
- PTFE & PFA hose, tubing & plastic fittings
- Rubber & thermoplastic hose & couplings
- Tube fittings & adapters
- Quick disconnects



HYDRAULICS

Key Markets

- Aerospace
- Aerial lift
- Agriculture
- Construction machinery
- Forestry
- Industrial machinery
- Mining
- Oil & gas
- Power generation & energy
- Truck hydraulics

Key Products

- Diagnostic equipment
- Hydraulic cylinders & accumulators
- Hydraulic motors & pumps
- Hydraulic systems
- Hydraulic valves & controls
- Power take-offs
- Rubber & thermoplastic hose & couplings
- Tube fittings & adapters
- Quick disconnects

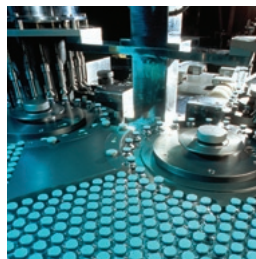

PNEUMATICS

Key Markets

- Aerospace
- Conveyor & material handling
- Factory automation
- Life science & medical
- Machine tools
- Packaging machinery
- Transportation & automotive

Key Products

- Air preparation
- Brass fittings & valves
- Manifolds
- Pneumatic accessories
- Pneumatic actuators & grippers
- Pneumatic valves & controls
- Quick disconnects
- Rotary actuators
- Rubber & thermoplastic hose & couplings
- Structural extrusions
- Thermoplastic tubing & fittings
- Vacuum generators, cups & sensors



PROCESS CONTROL

Key Markets

- Chemical & refining
- Food, beverage & dairy
- Medical & dental
- Microelectronics
- Oil & gas
- Power generation

Key Products

- Analytical sample conditioning products & systems
- Fluoropolymer chemical delivery fittings, valves & pumps
- High purity gas delivery fittings, valves & regulators
- Instrumentation fittings, valves & regulators
- Medium pressure fittings & valves
- Process control manifolds



SEALING & SHIELDING

Key Markets

- Aerospace
- Chemical processing
- Consumer
- Energy, oil & gas
- Fluid power
- General industrial
- Information technology
- Life sciences
- Military
- Semiconductor
- Telecommunications
- Transportation

Key Products

- Dynamic seals
- Elastomeric o-rings
- EMI shielding
- Extruded & precision-cut, fabricated elastomeric seals
- Homogeneous & inserted elastomeric shapes
- High temperature metal seals
- Metal & plastic retained composite seals
- Thermal management



ENGINEERING YOUR SUCCESS.

Sales Offices Worldwide

Parker Hannifin Corporation

Instrumentation Products Division
6575 Tram Road
Beaumont, TX 77713
USA
phone 409 924 0300
fax 409 924 0301
www.parker.com/ipdus

Parker Hannifin Corporation

Instrumentation Products Division
1005 A Cleaner Way
Huntsville, AL 35805
USA
phone 256 881 2040
fax 256 8815072
www.parker.com/ipdus

Parker Hannifin Corporation

Instrumentation Products Division
2651 Alabama Highway 21 North
Jacksonville, AL 36265-681
USA
phone 256 435 2130
fax 256 435 7718
www.parker.com/ipdus

Parker Hannifin plc

Instrumentation Products Division
Riverside Road
Pottington Business Park
Barnstaple, Devon EX31 1NP
England
phone +44 0 1271 313131
fax +44 0 1271 373636
email ipd@parker.com
www.parker.com/ipd

Catalog 4240 October 2009 DP



Parker Hannifin Corporation
Instrumentation Products Division
6575 Tram Road
Beaumont, Texas 77713
phone 409 924 0300
fax 409 924 0301
www.parker.com/ipdus

Your Local Authorized Parker Distributor