

Model 580 Digital Process Indicators Series

- *Economical and Flexible*
- *Accepts Thermocouple, RTD, Current, or Voltage Input*
- *Front Panel Alarm Capability*
- *Configures Easily*



Content

Specifications	page Accessories-34
Dimensional Drawings	page Accessories-36
Ordering Information	page Accessories-38

Model 580

This product data sheet discusses the features, benefits, and specifications of Rosemount® Model 580 digital process indicators. Two types of Model 580 process indicator are available: The pressure indicating Model 580D, and the temperature indicating Model 580T. For information about other Rosemount process indicators, see the **Other Rosemount Digital Process Indicators** section of this product data sheet.

Following the Rosemount Inc. philosophy of economically tiered pressure and temperature product lines, we now offer an economical alternative for control room digital process indication. The Model 580 series of digital process indicators are flexible, user-configurable units. They offer a reliable and cost-effective solution to your digital process indication needs, without compromising the performance that is characteristic of other Rosemount process indicators. In addition, these units are always readily available for shipment.

MODEL 580D FEATURES

The Model 580D Process Indicator is a dc input indicator that combines flexible scaling with four-digit resolution and high accuracy. This indicator accepts either 0–20 mA or 0–10 mV full scale input. You can scale these ranges, or any subset (4–20 mA, 1–5 V) of these ranges, and calibrate the indicator to display engineering units from the dc input. The Model 580D can be scaled to any range between –999 to 9999 using two push buttons located behind the snap-off lens. These buttons also set zero (low), full-scale (high), and the decimal point. In addition to flexible scaling, the microprocessor-based Model 580D provides excellent measurement stability, one digit repeatability, and 0.02 percent accuracy.

Another feature of the Model 580D is its ability to power transmitters directly through an optional, built-in dc power supply. When Option Code E is specified, the Model 580D provides 24 V dc at 30 mA. This power supply replaces more expensive external power supplies and is electrically floating, allowing it to be grounded anywhere. As shown in the wiring diagrams on page Accessories-37, wiring the power supply is easy because all connections (four-wire and two-wire) are made to the removable rear terminal block.

MODEL 580T FEATURES

The Model 580T supports 0.1° resolution for temperature measurements below 1000°, and for temperature measurements above 1000°, the Model 580T automatically switches to a 1° resolution. It also supports seven thermocouple sensor types: J, K, T, E, R, S, and B, and two 100 Ω three-wire, Platinum RTDs, either 0.00385 or 0.00392α. Select any one of these input types using a rotary switch located behind the snap-off lens. A DIP switch located in the same area enables you to display either degrees Fahrenheit or Celsius.

MODEL 580 OPTIONS

Model 580 process indicators are rack mountable onto standard 19-inch instrument racks, and support either an alarm setpoint or a multiple input option. To order either option, refer to the ordering information table. If not ordered originally with the indicator, either option can be installed easily in the field.

Alarm Setpoint

Easily set a single or dual alarm at any point within the display range with the Model 580 alarm option. Digitally set the setpoints using the two buttons on the front panel, and specify the high or low alarm selection by moving a jumper on the option card. If the indicator is set to dual alarm, you must set each alarm independently. A front panel LED clearly illuminates to indicate alarms.

The alarm setpoint option card includes a Form C, 0.5 A relay connection for external alarms or contact elements. For normally open or normally closed operation, relay terminals are provided at the rear of the indicator.

Multiple Inputs

The multiple inputs option enables a Model 580 to receive up to six commonly scaled inputs. A rotary switch on the front panel allows convenient selection of the desired input type, and a removable terminal strip promotes easy sensor wiring. In addition, both voltage and current inputs are acceptable, however they cannot be combined in a single unit.

Product Data Sheet

00813-0100-4695, Rev BA
Catalog 2002 – 2003

Model 580

Rack Adaptor Plates

For mounting Model 580 process indicators on standard 19-inch instrument racks, we provide optional adaptor plates. Four types of adaptors are available for mounting one to four indicators.

OTHER ROSEMOUNT DIGITAL PROCESS INDICATORS

In addition to the Model 580 process indicators, Rosemount Inc. offers the Model 751 Digital or Analog Process Indicator. Refer to the Model 751 product data sheet, document number 00813-0100-4378.

FIGURE 1. Model 580 Process Indicators

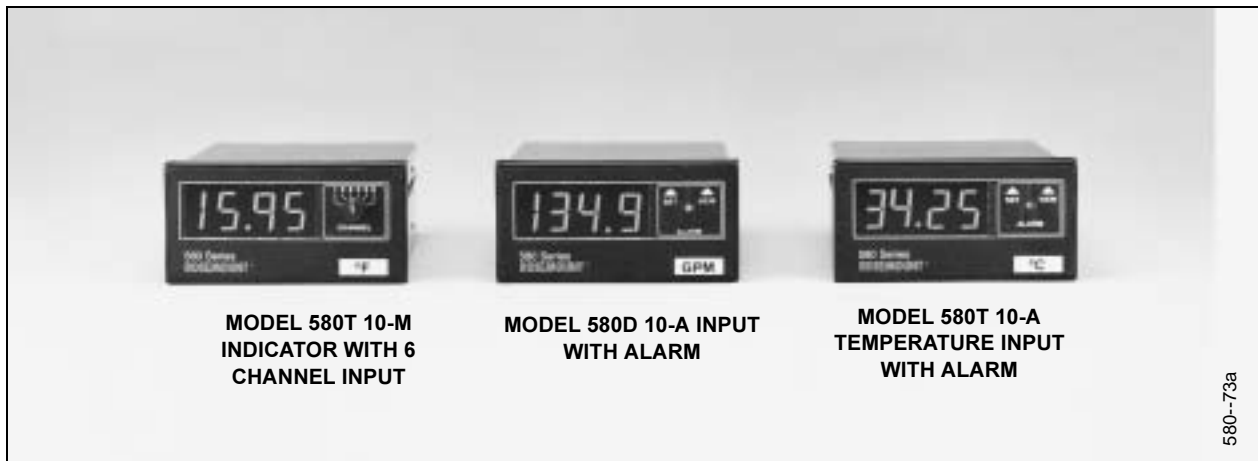

Specifications

MODEL 580D SPECIFICATIONS

Functional Specifications

Repeatability

±1 count

Stability with Temperature**Zero**

μ V/°C

Span

0.01% rdg/°C

Stability with Time

10 counts/year maximum

Noise Rejection**NMRR**

60 dB @ 50/60 Hz, ±0.1 Hz

CMRR

120 dB @ 50/60 Hz, ±0.1 Hz with 250 Ω unbalance

Overload Protection**Power Lead to Ground**

1,500 V dc or V ac rms

Across Inputs, Voltage

Up to 250 V dc or V ac for one minute, V+ to V-

Current

Up to 150 mA dc or mA ac for one minute, I+ to I-

Input Impedance**Voltage**

1 MΩ

Current

5 Ω

Read Rate

2 per second nominal

Display

7-segment red/orange
LED. 0.56 in. H (14.2)

Performance Specifications

Environmental Ranges**Operating Range**

40 to 110 °F (5 to 45 °C)

Storage

-40 to 150 °F (-40 to 65 °C)

Humidity

Less than or equal to 80% RH non-condensing

Alarm Relay Contact Rating

0.5 A @ 120 V ac (non-inductive load)
Form C

Power

115/230 V ac ±10%, 50/60 Hz, 400 Hz

Warranty

One year

Physical Specifications

Case Construction

One piece black plastic

Dimensions

See "Model 580 Dimensional Drawings" on page 36

Weight

1 lb. (454 g)

MODEL 580T SPECIFICATIONS

Functional Specifications

Repeatability

±1 count

Stability with Temperature**Zero**

1 μ V/°C

Span

0.01% rdg/°C

Thermocouple Reference Junction, Internal, Automatic

0.03 °C/°C, 40 to 110 °F (5 to 45 °C)

Break Detection

Upscale approximately 50 nA

Product Data Sheet

00813-0100-4695, Rev BA
Catalog 2002 – 2003

Model 580

Stability with Time

1°/year

Noise Rejection

NMRR

60 dB @ 50/60 Hz, ±0.1 Hz

CMRR

120 dB @ 50/60 Hz, ±0.1 Hz. with 250 Ω unbalance

Overload Protection

Power Lead to Ground

1500 V dc or V ac rms

Across Inputs, Thermocouple Model, T/C

Up to 250 V dc or V ac for one minute, V+ to V–

RTD

Up to 62 V dc or V ac for one minute, V+ to V–

Input Impedance

Thermocouple

20 MΩ, exclusive of break detect current effects

RTD

16.9 kΩ, V+ input. 16.9 kΩ, I input

RTD Lead Wire Error

at 150 μA excitation current

40 mΩ per ohm of equal resistance in V+ and V– leads

1 Ω per ohm of unbalance in V+ and V– leads

Point Update Rate

2 per second Nominal

1° readings

1 per second nominal

0.1° readings

TABLE 1. dc Range

INPUT RANGE ⁽¹⁾	DISPLAY RANGE ⁽¹⁾	ACCURACY
0–20 mA	User scalable between –999 and 9999	0.02% rdg, ±1 count
0–10 mV	User scalable between –999 and 9999	0.02% rdg, ±1 count

(1) Maximum sensitivity: 200 μV/count; 0/4 μA/count. Minimum sensitivity: 1 count.

TABLE 2. Thermocouple Ranges

SENSOR TYPE	1° RESOLUTION		1° RESOLUTION	
	RANGE/DISPLAY	ACCURACY (±) ⁽¹⁾	RANGE/DISPLAY	ACCURACY (±)
Iron-Constantan J	–337 to 1403 °F	1°, +0.03%	–99.9 to 999.9 °F	0.9°
	–205 to 762 °C	1°, +0.03%	–99.9 to 761.8 °C	0.5°
Chromel-Alumel K	–331 to 2510 °F	1°, +0.03%	–99.9 to 999.9 °F	0.9°
	–202 to 1377 °C	1°, +0.03%	–99.9 to 999.9 °C	0.5°
Copper-Constantan T	–346 to 755 °F	1°, +0.03%	–99.9 to 754.6 °F	0.9°
	–210 to 401 °C	1°, +0.03%	–99.9 to 401.1 °C	0.5°
Chromel-Constantan E	–338 to 1835 °F	1°, +0.03%	–99.9 to 999.9 °F	0.9°
	–205 to 1002 °C	1°, +0.03%	–99.9 to 999.9 °C	0.5°

Display

7-segment red/orange LED 0.56 in. H (14.2)

Performance Specifications

Environmental Ranges

Operating range

40 to 110 °F (5 to 45 °C)

Storage

–40 to 150 °F (–40 to 65 °C)

Humidity

Less than or equal to 80% RH non-condensing

Multi-input Option Accuracy

Add ±0.5 °C/±1 °F to instrument accuracy specification

Alarm Relay Contact Rating

0.5 A @ 120 V ac (non-inductive load) Form C

Power

115/230 V ac ±10%, 50/60 Hz, 400 Hz

Warranty

One year

Physical Specifications

Case Construction

One piece black plastic

Dimensions

See "Model 580 Dimensional Drawings" on page 36

Weight

1 lb. (454 g)

TABLE 2. Thermocouple Ranges

SENSOR TYPE	1° RESOLUTION		1° RESOLUTION	
	RANGE/DISPLAY	ACCURACY (±) ⁽¹⁾	RANGE/DISPLAY	ACCURACY (±)
Platinum- Platinum 13%, Rhodium R	32 to 3216 °F 0 to 1769 °C	1°, +0.05% 1°, +0.05%		
Platinum- Platinum 10%, Rhodium S	32 to 3218 °F 0 to 1770 °C	1°, +0.05% 1°, +0.05%		
Platinum 30%, Rhodium- Platinum 6%, Rhodium B	601 to 3325 °F 316 to 1829 °C	1°, +0.05% 1°, +0.05%		

(1) Accuracy percentage is of reading, ±1 digit.

TABLE 3. RTD Range

SENSOR TYPE	1° RESOLUTION		1° RESOLUTION	
	RANGE/DISPLAY	ACCURACY (±) ⁽¹⁾	RANGE/DISPLAY	ACCURACY (±)
Platinum 100 Ω	-329 to 1585 °F	1°, +0.03%	-99.9 to 999.9 °F	0.9°
3-wire α 0.00385	-200 to 863 °C	1°, +0.03%	-99.9 to 862.6 °C	0.5°
Platinum 100 Ω	-332 to 1563 °F	1°, +0.03%	-99.9 to 999.9 °F	0.9°
3-wire α 0.00392	-202 to 851 °C	1°, +0.03%	-99.9 to 850.8 °C	0.5°

(1) Accuracy percentage is of reading, ±1 digit.

Dimensional Drawings

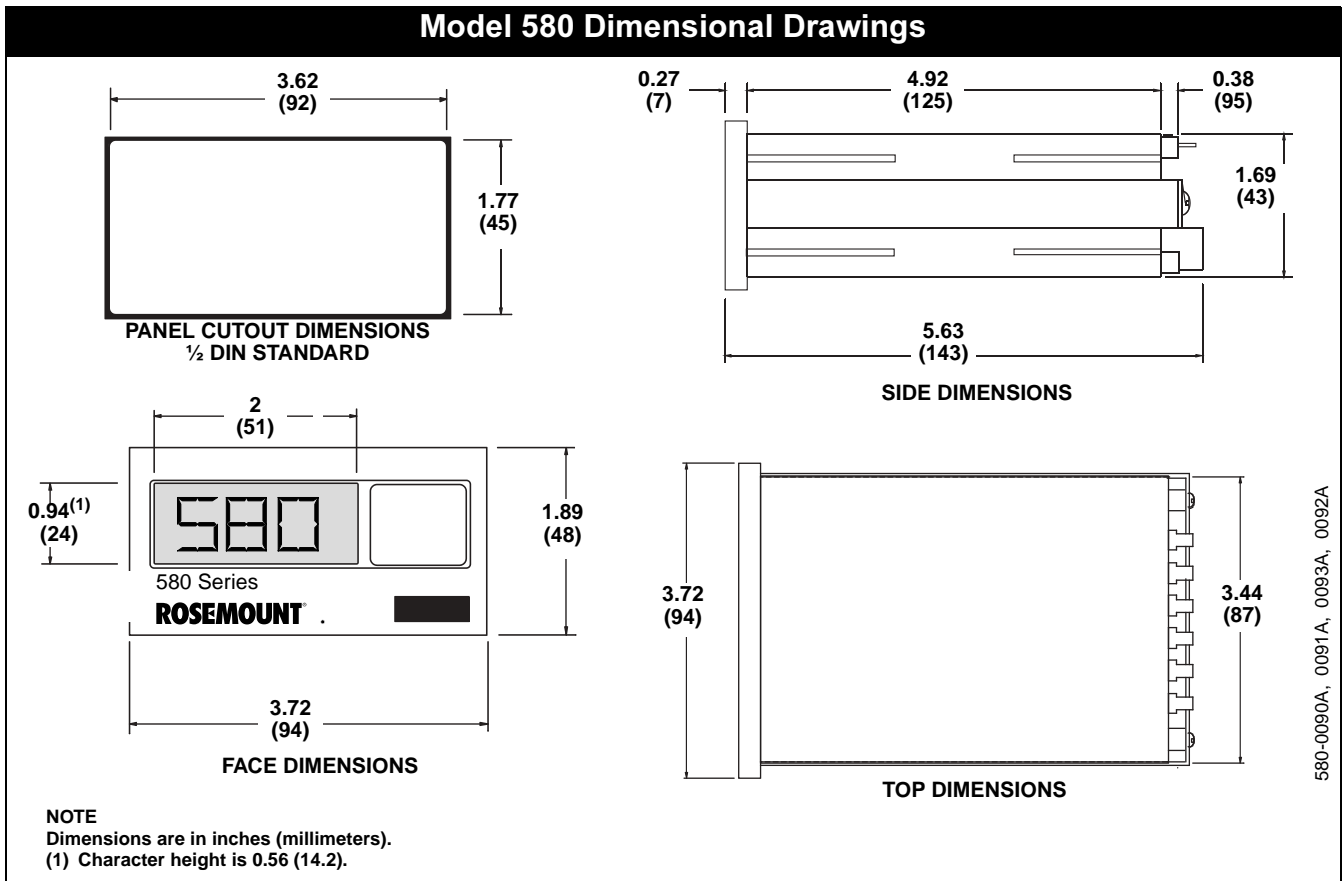

Models 580D and 580T Wiring Diagrams

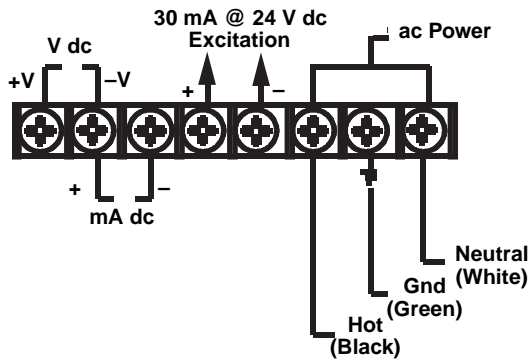

MODEL 580D

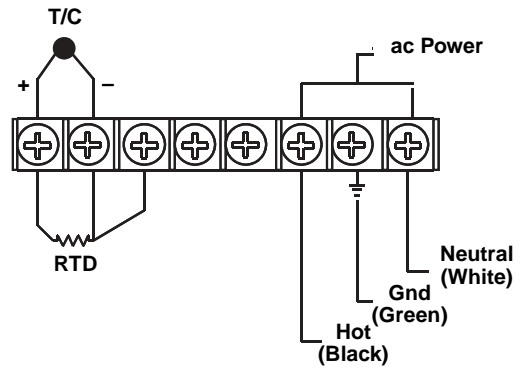

MODEL 580T

580-0086A, 0089A

4- and 2-Wire Excitation Wiring Diagrams

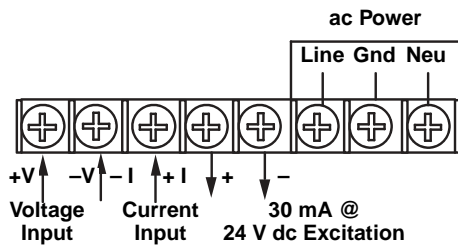

4-WIRE MODE

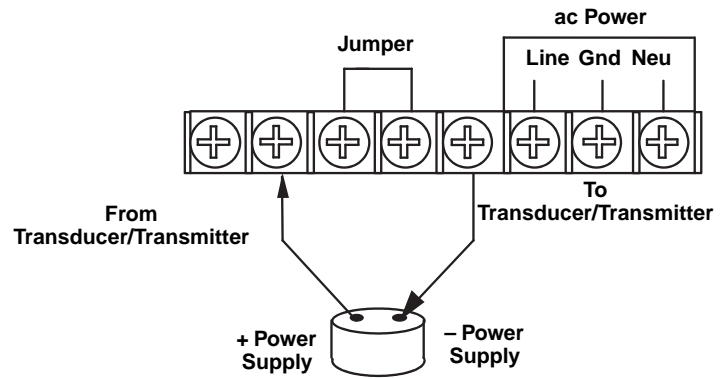

2-WIRE CURRENT LOOP MODE

580-0094A, 0095A

Product Data Sheet

00813-0100-4695, Rev BA
Catalog 2002 – 2003

Model 580

Ordering Information

Model	Product Description
580	Digital Process Indicator
Code	Input
D	dc Input
T	Temperature Sensor Input
Code	Line Voltage
10	Set for 115 V ac
20	Set for 230 V ac
Code	Options
A	Single Alarm
B	Dual Alarm
M	Six Channel Selection
E	30 mA @ 24 V dc Excitation (Model 580D only)

Typical Model Number: 580 D 10 A

Spare Parts List

Part Number	Description
R580D-HBK1	Owner's Manual
R580T-HBK1	Owner's Manual
RKS1	19-in. Rack Mount Adapter
RKS2	19-in. Rack Mount Adapter
RKS3	19-in. Rack Mount Adapter
RKS4	19-in. Rack Mount Adapter

*Rosemount and the Rosemount logotype are registered trademarks of Rosemount Inc.
PlantWeb is a registered trademark of one of the Emerson Process Management group of companies.
All other marks are the property of their respective owners.*

Emerson Process Management

Rosemount Inc.
8200 Market Boulevard
Chanhassen, MN 55317 USA
T (U.S.) 1-800-999-9307
T (International) (952) 906-8888
F (952) 949-7001

Fisher-Rosemount GmbH & Co. Fisher-Rosemount Singapore Pte Ltd.
Shipping Address: 1 Pandan Crescent
Argelsrieder Feld 3 Singapore 128461
82234 Wessling Tel (65) 777-8211
Germany Fax (65) 777-0947
Tel 49 (8153) 9390 AP.RMT-Specialist@emersonprocess.com
Fax 49 (8153) 939172

www.rosemount.com

