

Class 150 • Outside Screw & Yoke • Flexible Wedge Disc

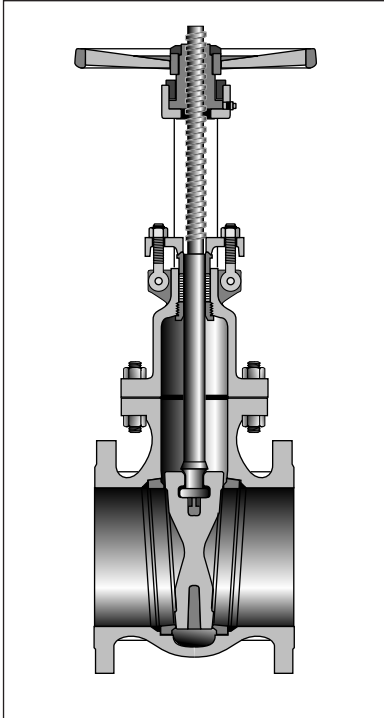

Figure 47XU-F
Flanged

Size Range:
2 - 24 inches

Pressure Temperature Rating
Carbon Steel
ASTM A216 Grade WCB
285 psi @ -20°F to 100°F

Materials of Construction

Description	Material
Body	A216 WCB
Bonnet	A216 WCB
Seat Rings	Hardfaced
Disc	13% CR Overlay
Stem	410 SS
Packing	Graphite
Bonnet Gasket	Soft Iron
Back Seat	410 SS
Yoke Sleeve	D2 Ni-Resist
Retaining Nut	Malleable or Steel
Gland	Steel
Gland Flange	Steel
Eye Bolt	Steel
Eye Bolt Nuts	Steel
Pins	Steel
Bonnet Studs	A193 Gr. B7
Bonnet Nuts	A194 Gr. 2H
Handwheel	Malleable, Ductile, or Steel
Handwheel Nut	Ductile or Steel
I.D. Tags	SS
I.D. Pins	Steel
Spacer	Steel
Grease Fittings	Steel

Industry Standards

Steel Valves	ANSI B16.34
Face-to-Face/End-to-End	ANSI B16.10
Flange Dimensions	ANSI B16.5
Basic Design	API 600
Testing	API 598
Acceptance	API RP591

Dimensions and Weights

Valve Size	Weight (pounds)	Dimensions (inches)		
		A	B Valve Open	C
2	46	7.00	16.50	8.00
2½	70	7.50	18.00	8.00
3	76	8.00	21.00	9.00
4	110	9.00	23.00	10.00
6	175	10.50	31.00	12.00
8	310	11.50	39.00	14.00
10	455	13.00	46.75	16.00
12	650	14.00	55.00	18.00
14	860	15.00	60.50	20.00
16	1120	16.00	68.50	20.00
18	1400	17.00	77.50	23.62
20	2125	18.00	84.00	23.62
24	3120	20.00	99.00	28.35

