Install Instruction

The front wheel of two-wheel drive model car is controlled by its servo to provide the steering power, and the rear wheel adopts gear drive via connecting the rod. This model vehicle has a good differential performance because it adopts 370 high-speed motor as the power of the whole car and equipped with 34:1 high-speed reducer, high torque, each wheel be lined with 64mm sponge, high capacity lithium battery with 7.4V.

Please take a look at listing first to ensure all parts are complete before installing. If you are a beginner, be sure to read the follow instruction thanks to the screw has multiple specifications.

Screw Specification:

M3 Screw: used to fix the chassis, holder, servo and copper column.

M3 Flat Head Screw: used to fix the motor.

M2.5*8 Screw: used to fix the steering knuckle.

M2.5*12 and M2.5*20 Screw: used to fix the ball and rod.

M4 Screw and nut: used to wheel.

It is very important to ensure the midpoint (90°) / zero point (0°) / 180 degree point (180°) of the servo.

The specific installation steps are as follows:

No.1 Install the rear-wheel-drive, ensure the positive and negative sides of the chassis. You need to use the screw fixed the gear and coupling what matched with the 'L' spanner.

The list of components used for this step is:

- M3*8 Screw * 5
- M3*8 Nut * 5
- M3*5 Flat Head Screw * 2

And the Part 1 is our default installation way.

Part 1:



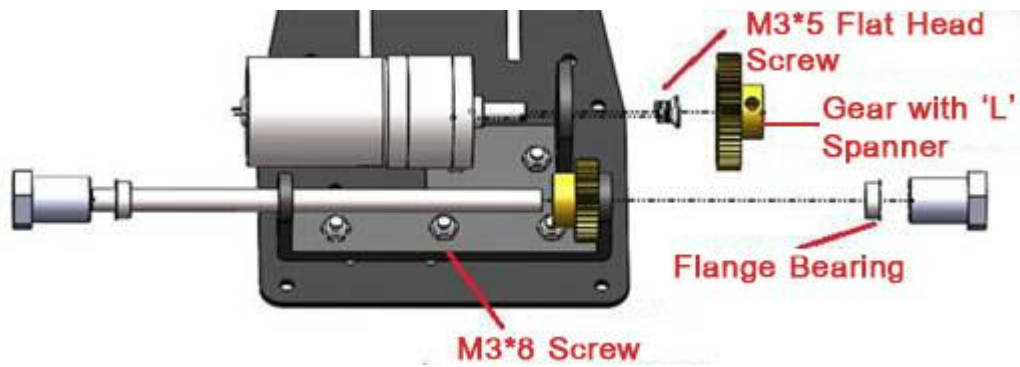

Part 2:

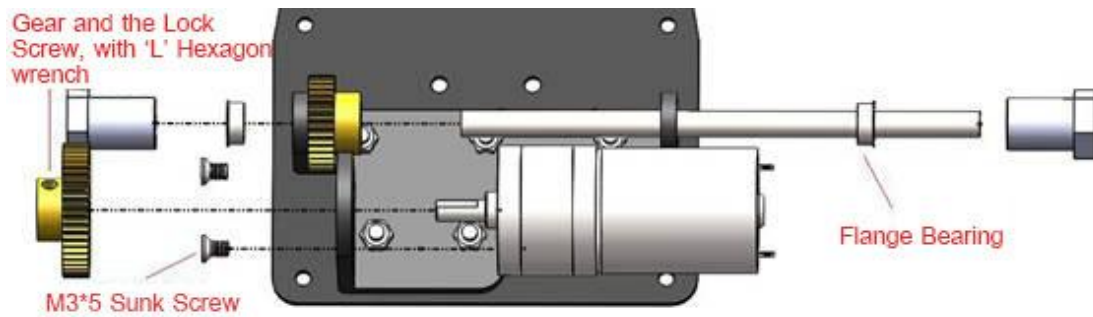

No.2 Fixed the Steering Knuckle and wheel



No.3 Fixed the Servo and Rudder Angle-Fixed the servo on the 'L' holder, which guided by the criteria that the servo is before holder. And need to fix the position of the red hole in the figure.

Components List:

- M3*6 Screw * 1
- M3*8 Screw * 4
- M3 Nut * 1
- M2.5*12 Screw * 1
- M2.5 Locknut * 1

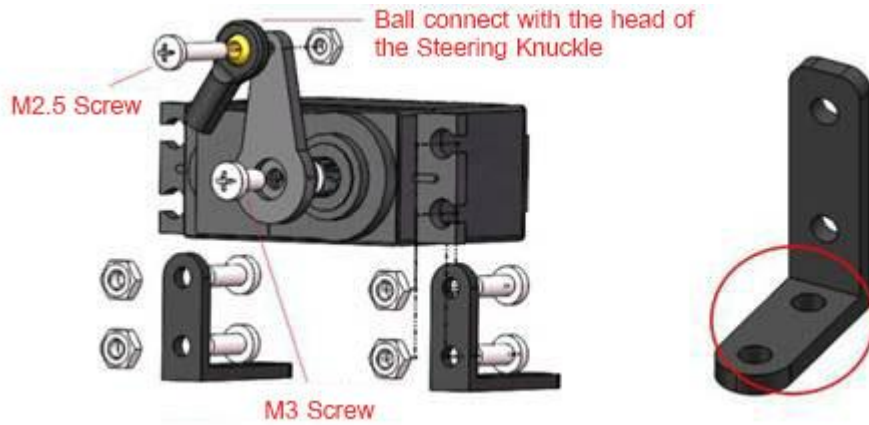

No.4 Connect the Steering Knuckle – Connect the wheels of the No.2 with ball and rod, among that the hole space of the long rod is 65mm, else 48mm.

Components List:

- M2.5*8mm or 12mm Screw * 1
- M2.5*20mm Screw * 1
- M2.5 Locknut * 1



No.5 Integrate No.3 and No.4 into the chassis, then fixed.

Components List:

- M3*22mm copper column * 4
- M2.5*8mm Screw * 4
- M3*8mm Screw * 12
- M3 Nut *4

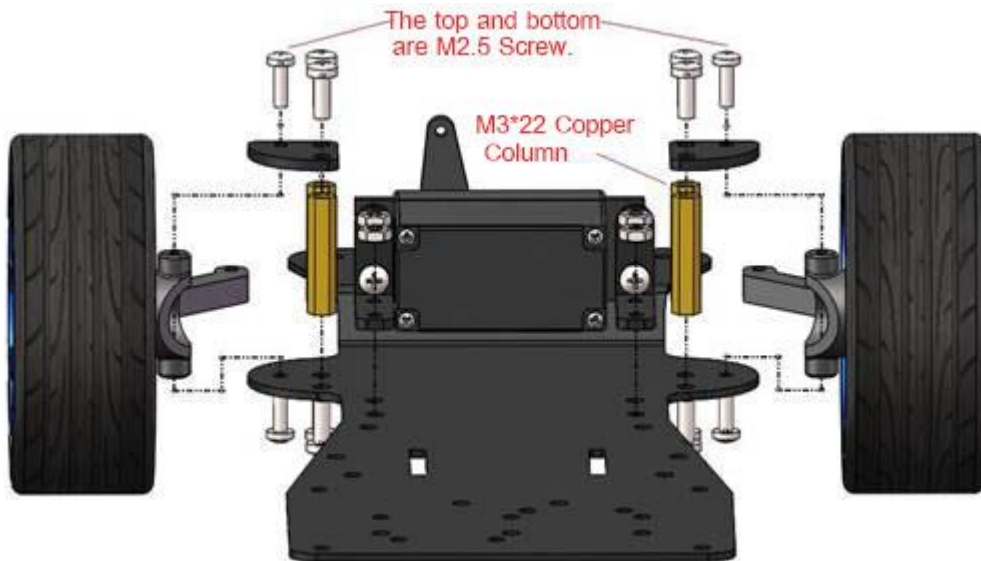

No.6 Install sponge to avoid collision

The red hole of the figure is fixed hole and pressed the sponge with gasket.

Components List:

- M3*8mm Screw * 8
- M3 Gasket * 4
- M3*16mm Copper Column * 4



No.7 Add two acrylic plates into the chassis.

Components List:

- M3*22mm Copper Column * 4
- M3*35mm Copper Column * 4
- M3*8 Screw * 16

Specification:

- White: Fixing hole
- Blue: the Fixing hole of arduino UNO
- Cyan: the Fixing hole of raspberry pi

-
- Yellow: the Fixing hole of the pinboard
 - Rectangle: Switch hole

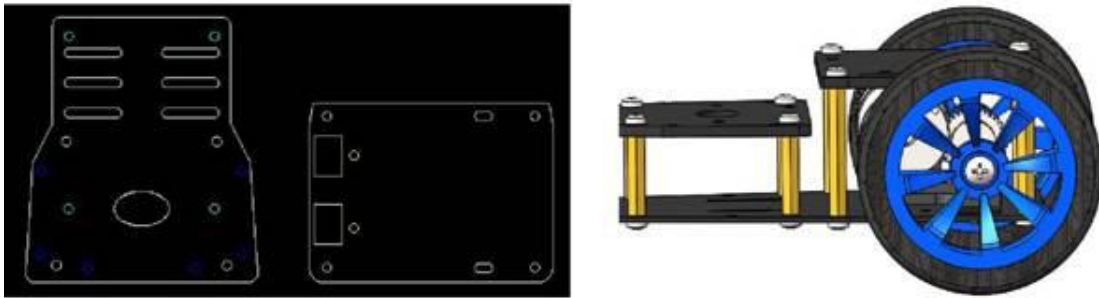

Up to this point, the whole model car had already installed. In addition, you can install your power and master board into the car to make it a smart car.

