



Professional Radio GP Series

**Power Distribution and Controller
Service Information**

Computer Software Copyrights

The Motorola products described in this manual may include copyrighted Motorola computer programs stored in semiconductor memories or other media. Laws in the United States and other countries preserve for Motorola certain exclusive rights for copyrighted computer programs, including the exclusive right to copy or reproduce in any form, the copyrighted computer program. Accordingly, any copyrighted Motorola computer programs contained in the Motorola products described in this manual may not be copied or reproduced in any manner without the express written permission of Motorola. Furthermore, the purchase of Motorola products shall not be deemed to grant, either directly or by implication, estoppel or otherwise, any license under the copyrights, patents or patent applications of Motorola, except for the normal non-exclusive royalty-free license to use that arises by operation of law in the sale of a product.

Table of Contents

Chapter 1 THEORY OF OPERATION

1.0 Overview	1-1
2.0 Radio Power Distribution	1-1
3.0 Controller Circuits	1-2
3.1 Controller Architecture	1-2
3.2 MCU Digital Architecture	1-2
3.3 Real Time Clock	1-3
3.4 ModB/Vstby Supply	1-4
3.5 Audio/Signaling Architecture	1-4

Chapter 2 TROUBLESHOOTING CHARTS

1.0 UHF/ UHF2 Controller.....	2-1
1.1 All models except those with PCB 8486458Z03.....	2-1
1.2 Models with PCB 8486458Z03	2-2

Chapter 3 CONTROLLER SCHEMATICS

1.0 Allocation of Schematics and Circuit Boards	3-1
2.0 Controller - Set 1 (PCB 8480450Z03, 8485641Z02, 8480587Z01, 8485677Z01, 8480641Z03)	3-3
3.0 Controller - Set 2 (PCB 8480450Z13/14, 8485641Z06).....	3-9
4.0 Controller - Set 3 (PCB 8486458Z03, 8486686Z02).....	3-15

THEORY OF OPERATION

1.0 Overview

This Chapter provides a detailed theory of operation for the power distribution and controller circuits in the radio. The components for these circuits are contained on the Main Board. Refer to the RF sections of this manual for the component location details and the parts lists for these circuits.

2.0 Radio Power Distribution

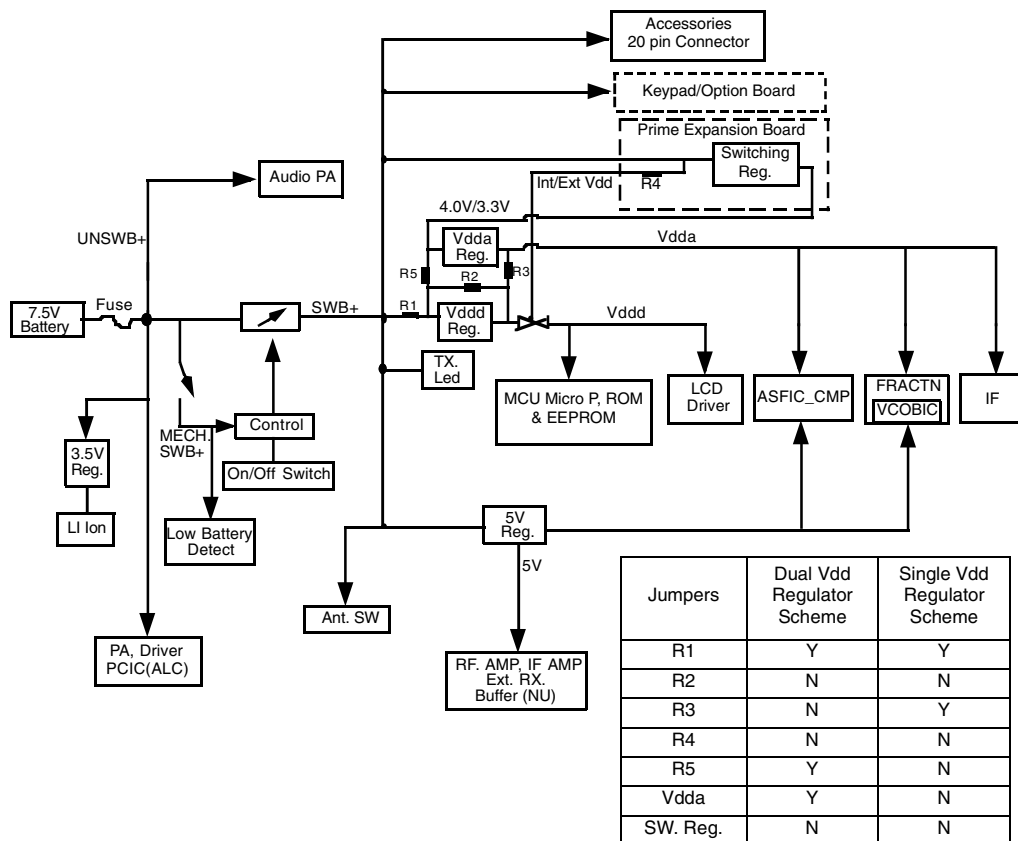

Figure 1-1 DC Power Distribution Block Diagram

Figure 1-1 illustrates the DC distribution throughout the radio board. A 7.5V battery (BATT 7.5V) supplies power directly to the electronic on/off control as UNSWB+. When the radio is turned on, MECH_SWB+ (on/off/volume control) will trigger the electronic on/off control (momentary-on path), then SWB+ is distributed as shown in Figure 1-1. Vdda from 3.3V Vdda regulator will then supply the microprocessor. Data is then sent to ASFIC_CMP to turn on GCB4(DAC). GCB4 will take over the momentary-on path within 12ms. SWB+ will continue to support the whole board until the radio is turned off.

Radio will be turned-off on two conditions;

1. MECH_SWB+ turned off
2. Low battery

When low battery level is detected by the microprocessor through both conditions above, it will store the radio personality data to EEPROM before turning off.

3.0 Controller Circuits

3.1 Controller Architecture

The controller board is the central interface between the various subsystems of the radio. It is separated into MCU digital and audio/signalling architectures as shown in Figure 1-2.

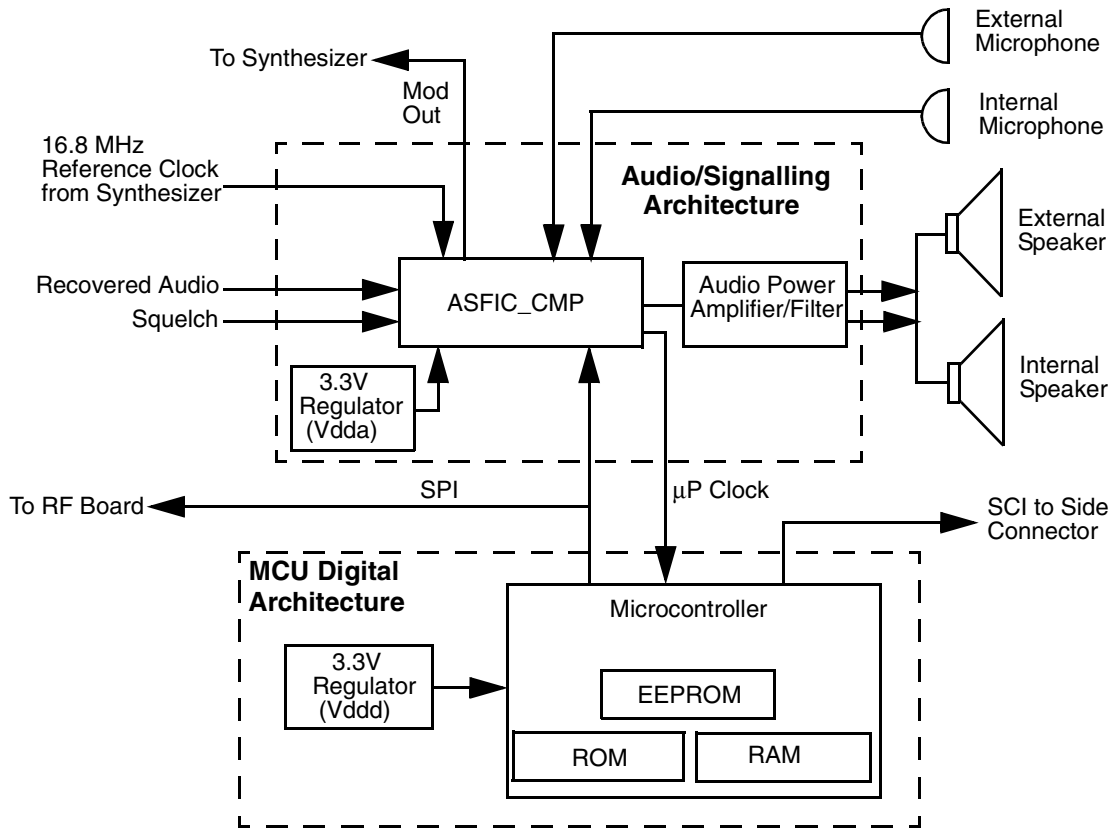

Figure 1-2 Controller Block Diagram

3.2 MCU Digital Architecture

(Refer to Figure 1-2, the Microprocessor and the Memory schematic diagrams)

The digital architecture portion consists of a microcontroller and associated EEPROM, RAM, and ROM memories. The architecture is commonly used for both low-tier and high-tier products and also includes conventional and trunking portables. Combinations of different size RAM and ROM are available to support various application software. RAM supports 8KB and 32KB sizes. ROM supports 128KB, 256KB, and 512KB sizes. Table 1-1 shows the ROM, RAM and EEPROM requirements for different applications.

Table 1-1 Radio Memory Requirements

RADIO		ROM (KB)	EXT RAM (KB)	EEPROM (KB)
Conventional MDC	GP140	128K	-	8K
Conventional 5 Tone	GP320, GP340	512K	16K	16K
Conventional 5 Tone	GP360, GP380	512K	16K	16K
Privacy Plus	GP240, GP280	512K	16K	16K
SmartZone	GP540, GP580	512K	16K	16K
MPT	GP640, GP680	512K	16K	16K
MPT	GP1280	512K	16K	16K

3.3 Real Time Clock

(Refer to Figure 1-3 and the Microprocessor schematic diagram)

Radios with displays support a Real Time Clock (RTC) module for purposes of message time stamping and time keeping. The RTC module resides in the microcontroller. The clock uses a back-up Lithium Ion battery for operating power when the primary battery is removed.

3.3.1 Circuit Description

The RTC module circuit, shown in Figure 1-3, is powered by the ModB/Vstby pin and PI6/PI7 from the crystal oscillator circuit. A clock frequency of 38.4kHz from a crystal oscillator provides the reference signal which is divided down to 1 Hz in the processor.

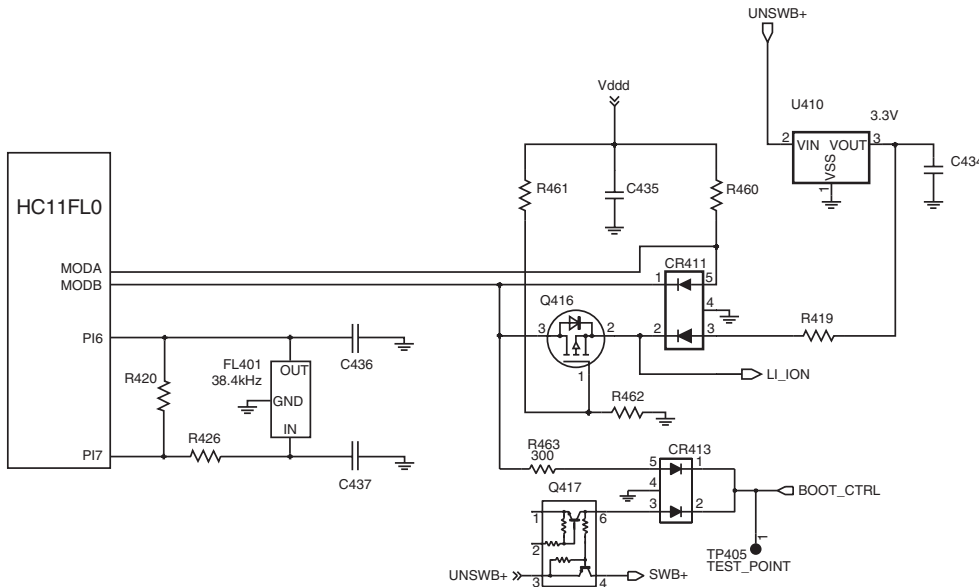

Figure 1-3 RTC Circuit

As the RTC module is powered separately from the processor Vdd, the RTC is kept active through the ModB / Vstby pin which provides the Lithium battery back-up power when the radio is switched off.

A MOSFET Q416 switches in the LiO supply when Vdd is removed. Q416 also provides isolation from BOOT_CTRL function in the event of radio program flashing. The 3.3V regulator charges the Lithium battery.

3.4 ModB/Vstby Supply

The supply to the ModB/Vstby pin varies depending on the conditions listed in Table 1-2.

Table 1-2 ModB/Vstby Supply Modes

Condition	Circuit Operation
Radio On	Vdd supply voltage via CR411
Radio Off	<ul style="list-style-type: none"> • Vdd turned off • Q416 gate pulled low by R462 • Q416 switched on • U410 supplies 3.2V to ModB/Vstby
Primary battery removed	<ul style="list-style-type: none"> • Vdd turned off • Q416 gate pulled low by R462 • Q416 switched on • Lithium battery provides 3.2V to ModB/Vstby
Flash Mode	<ul style="list-style-type: none"> • Boot_Ctrl line pulled low • ModA & ModB go low • Processor in boot-strap mode

3.5 Audio/Signalling Architecture

(Refer to Figure 1-2 and the ASFIC/ON_OFF and Audio Power Amplifier schematic diagrams)

The audio/signalling/filter/companing IC (ASFIC_CMP) and the audio power amplifier, shown in Figure 1-2, form the main components of the audio/signalling architecture section of the controller board. Inputs include a 16.8 MHz clock from the synthesizer, recovered audio and squelch, MCU control signals, and external or internal microphones. Outputs include a microprocessor clock (uP), modulator output to the synthesizer, and amplified audio signals to an internal or external speaker.

TROUBLESHOOTING CHARTS

1.0 UHF/ UHF2/ 800MHz Controller

1.1 All models except those with PCB 8486458Z03

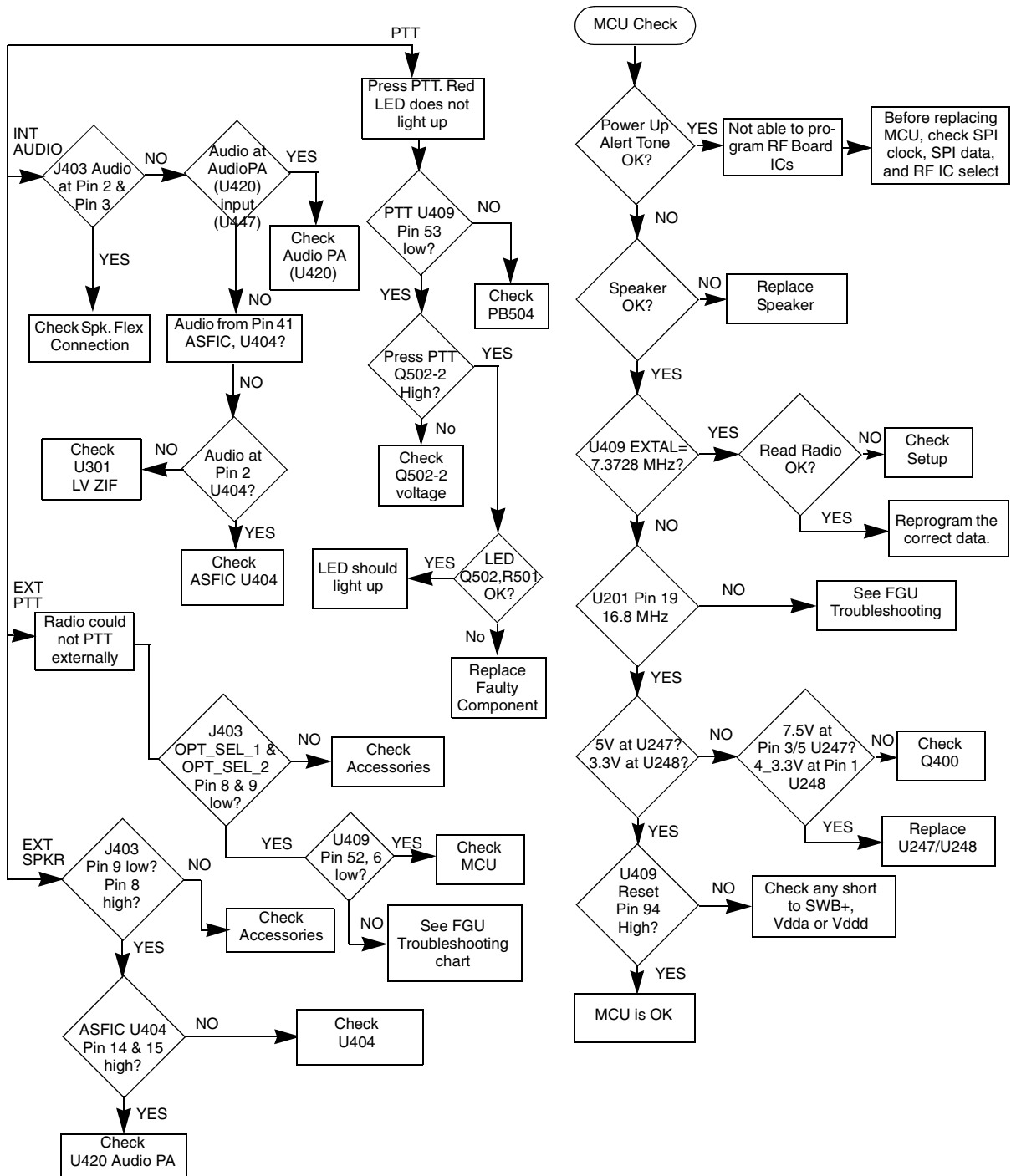

1.2 Models with PCB 8486458Z03

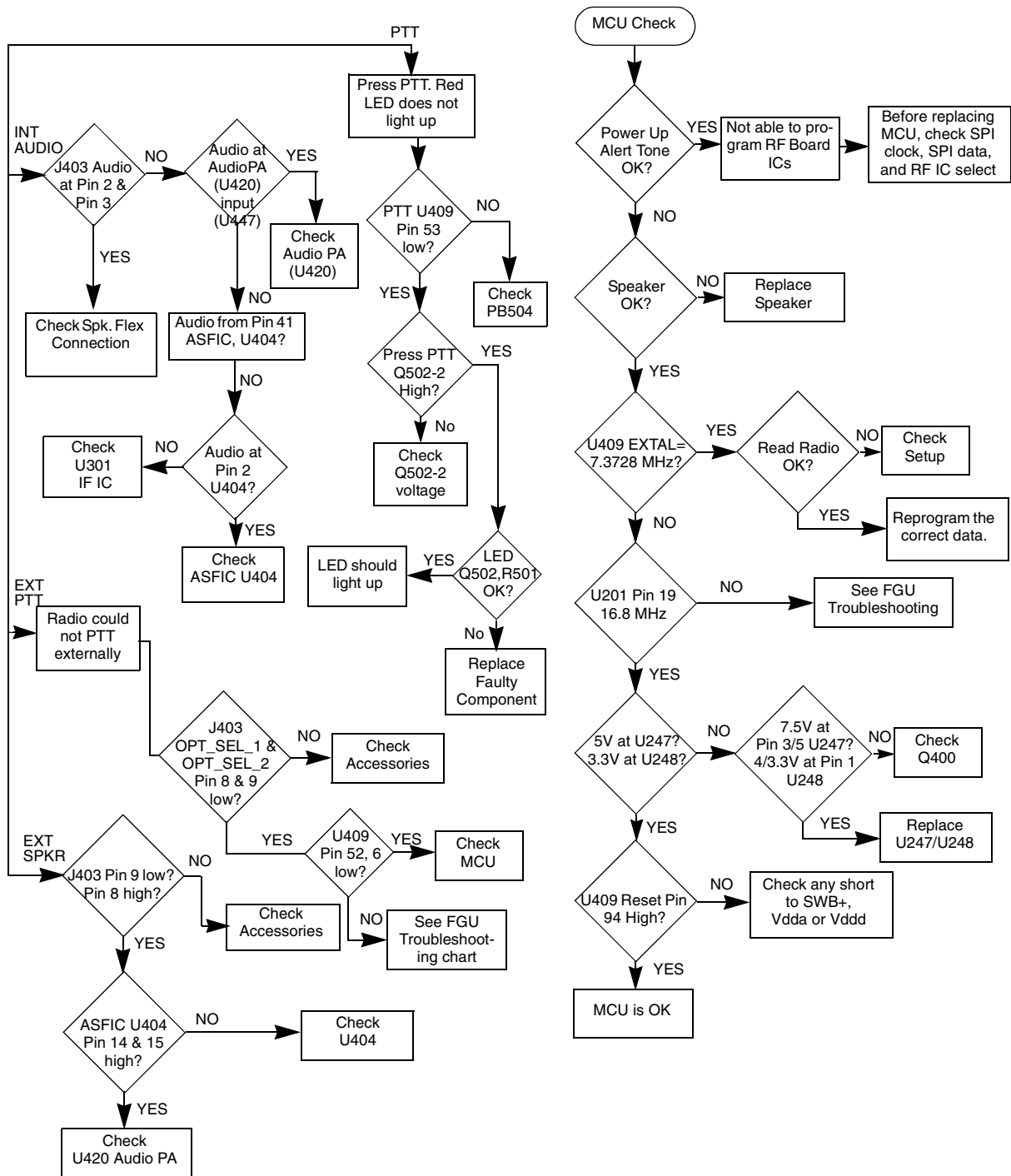

CONTROLLER SCHEMATICS

1.0 Allocation of Schematics and Circuit Boards

The Controller circuits are contained on the printed circuit board (PCB) containing the RF circuits. This Chapter shows the schematics for the Controller circuits only, refer to the relevant RF section for details of the related RF circuits, the PCB component layouts and the Parts Lists. The Controller schematic diagrams and the related PCB and parts list are shown in the tables below:

Table 3-1 Schematics - Set 1

PCBs : 8480450Z03 8485641Z02 8480587Z01 8485677Z01 8480641Z03	UHF UHF2 UHF GP1280 UHF2 GP1280 800 MHz
SCHEMATICS Overall Controller Schematic ASFIC/ ON_OFF Microprocessor Interface Memory Audio Power Amplifer	Page 3-3 Page 3-4 Page 3-5 Page 3-6 Page 3-6 Page 3-7

Table 3-2 Schematics - Set 2

PCBs : 8480450Z13/14 8485641Z06	UHF UHF2
SCHEMATICS Overall Controller Schematic ASFIC ON_OFF Microprocessor Memory Interface Audio Power Amplifer	Page 3-9 Page 3-10 Page 3-10 Page 3-11 Page 3-12 Page 3-13

Table 3-3 Schematics - Set 3

PCBs : 8486458Z03 8486686Z02	UHF UHF2
SCHEMATICS Overall Controller Schematic ASFIC ON_OFF Microprocessor Memory Interface Audio Power Amplifier	Page 3-15 Page 3-16 Page 3-17 Page 3-18 Page 3-18 Page 3-19

2.0 Controller - Set 1 (PCB 8480450Z03, 8485641Z02, 8480587Z01, 8485677Z01, 8480641Z03)

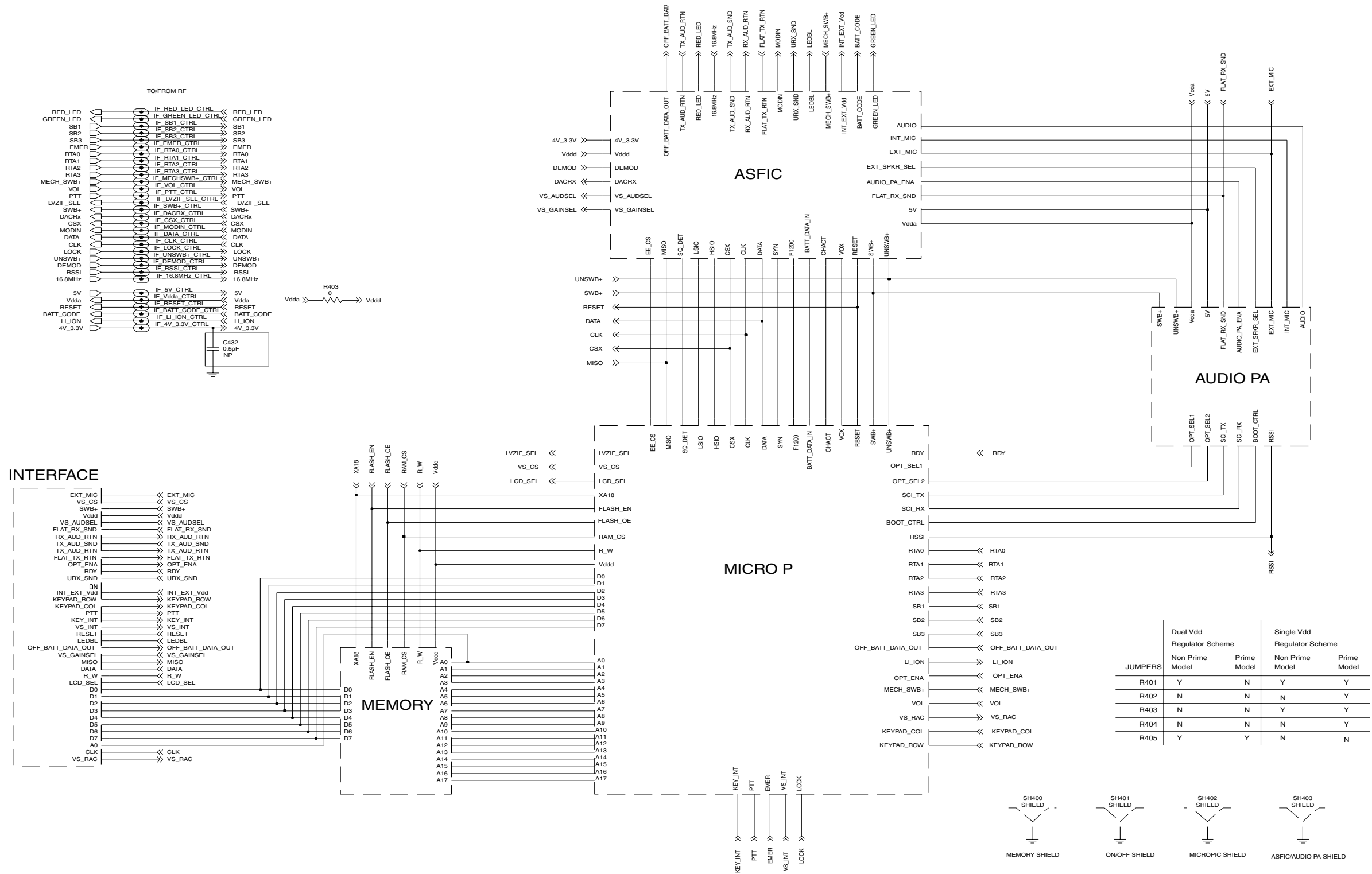

FL0830275-O

Overall Controller Schematic

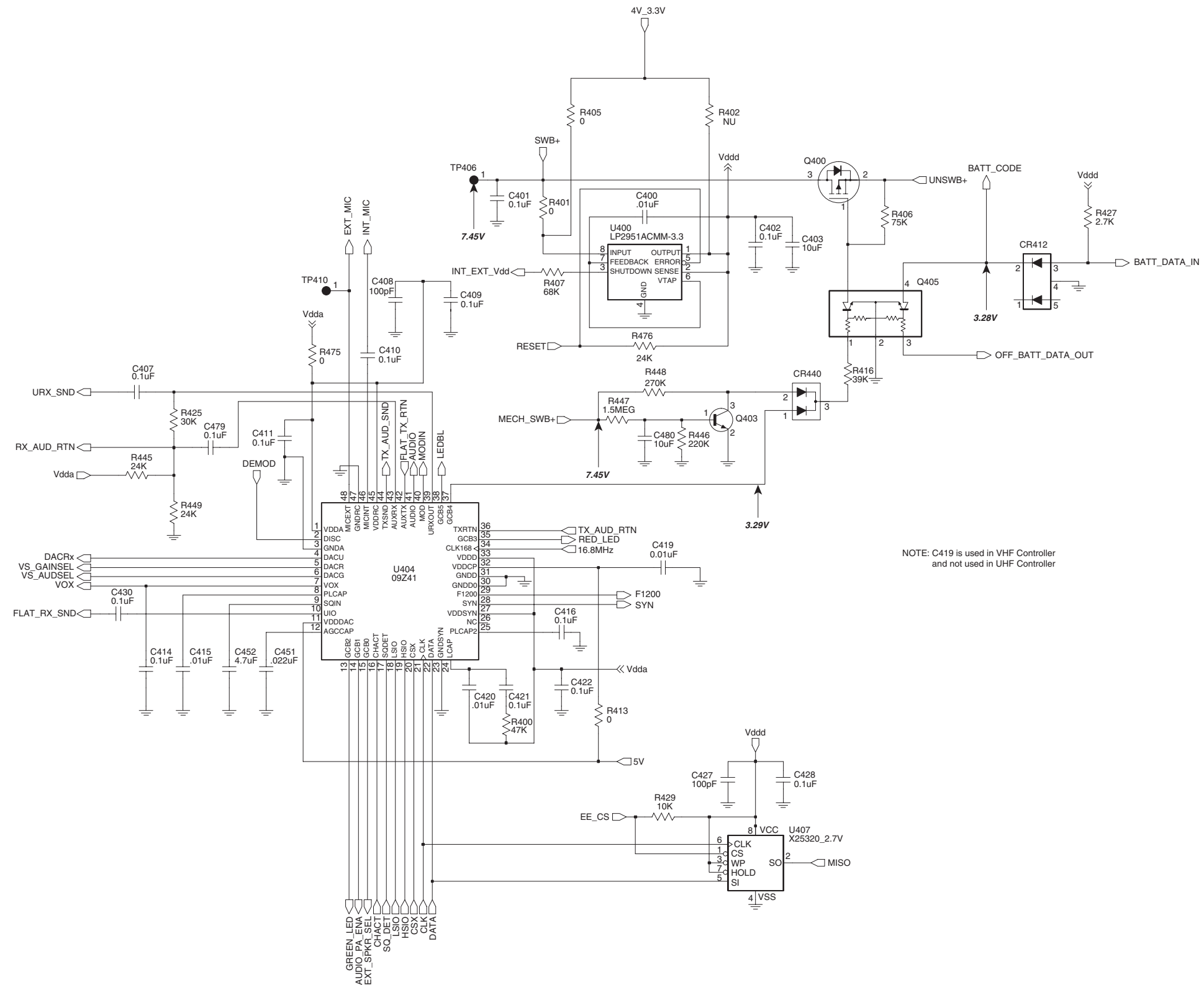

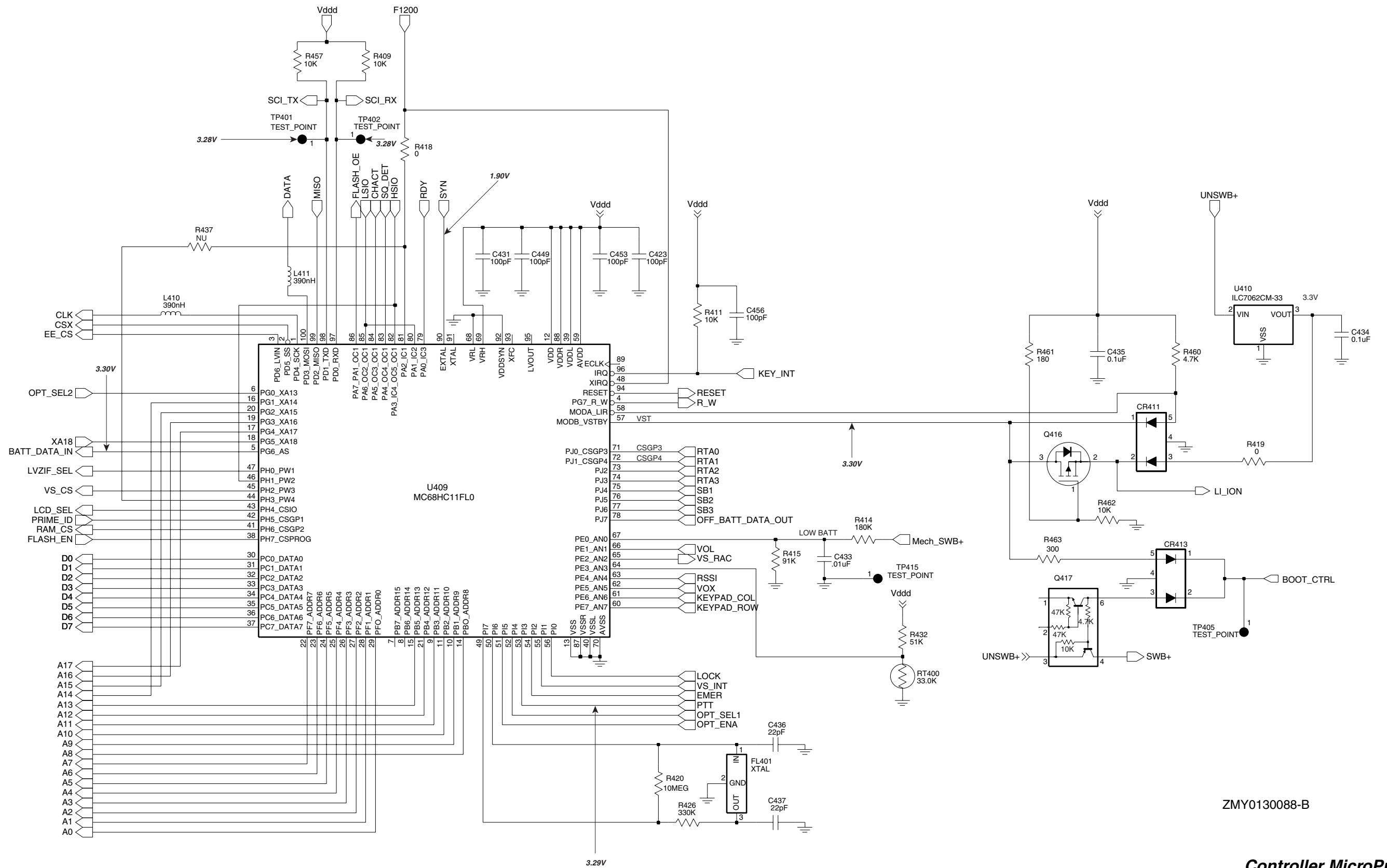

ZMY0130088-B

Controller MicroProcessor

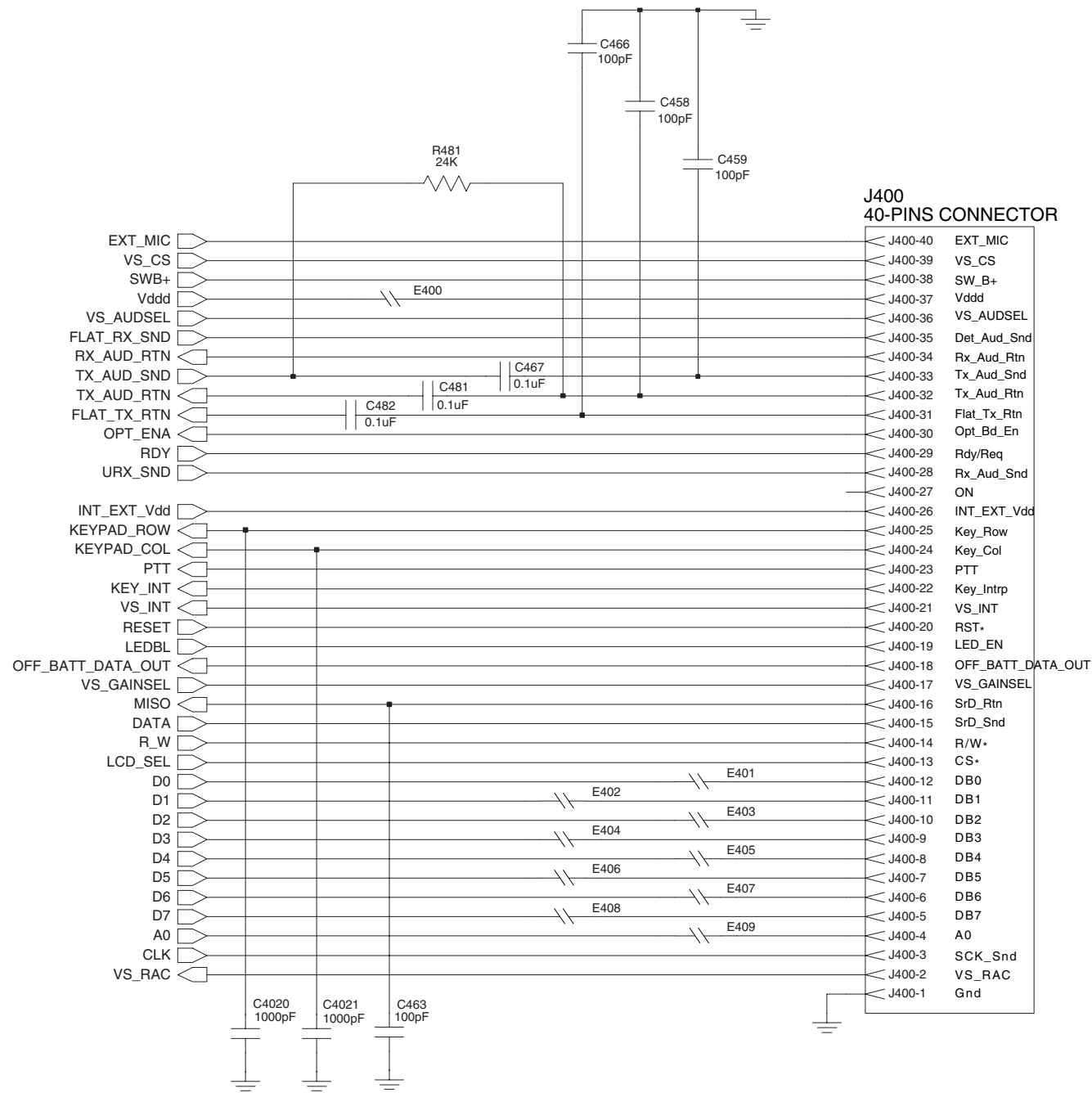

Note: C4020 and C4021 not placed on PCBs 8480450Z03, 8485641Z02, 8480587Z01, 8485677Z01, 8486062B12, 8485726Z01.

ZWG0130360-A

Controller Interface

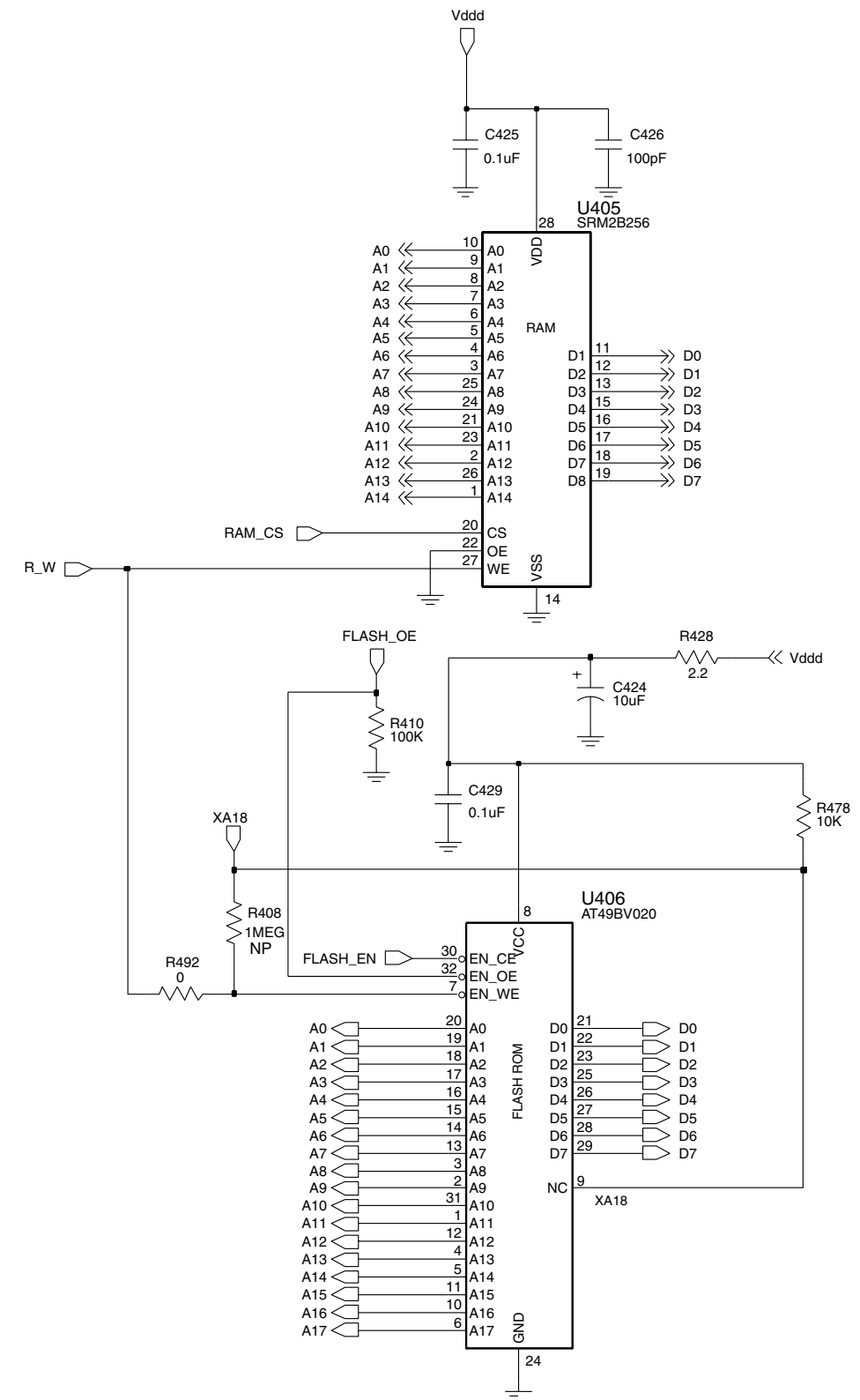

FL0830279-O

Controller Memory

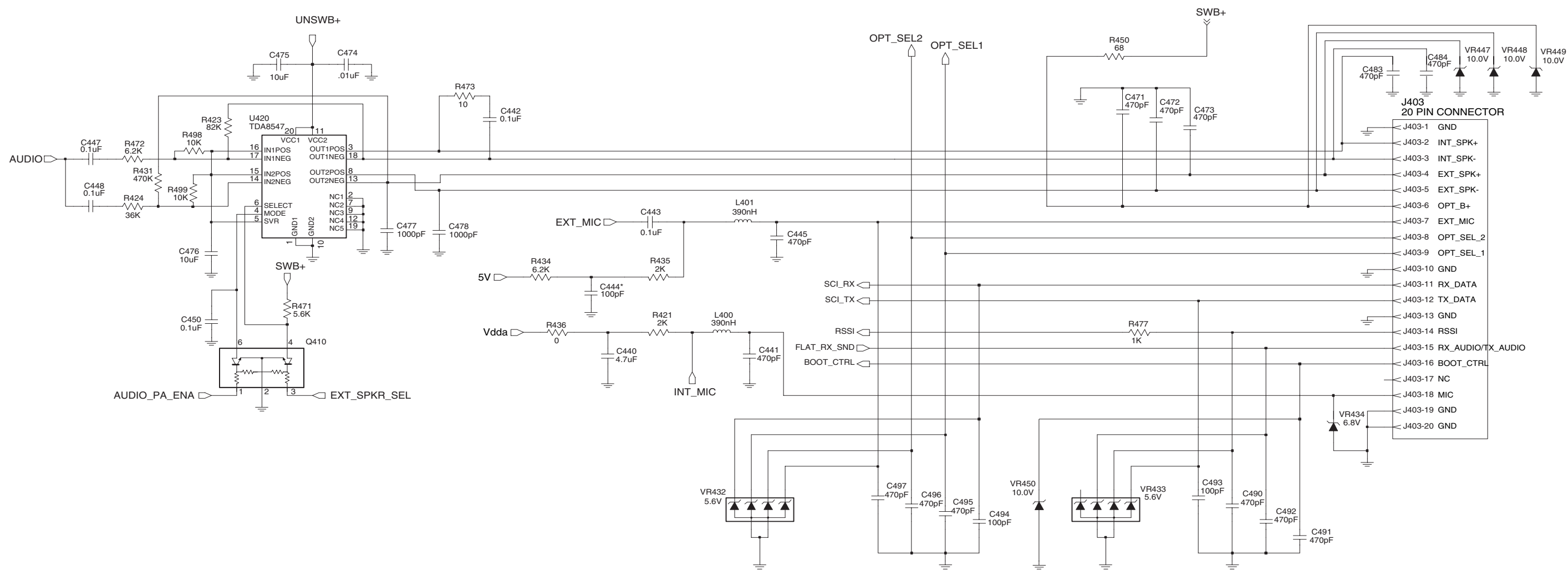

Band	PCB	R472	R423	C474	C477	C478	C445	C441	C471	C472	C473	C483	C484	C490	C491	C492	C495	C496	C497	VR445	VR446	R498	R499
UHF B1	8480450Z03																						
UHF B2	8485641Z02	36K	470K	not placed	not placed	not placed	100pF	100pF	100pF	470pF	470pF	not placed	not placed	100pF	100pF	100pF	100pF	100pF	100pF	10.0V	10.0V	not placed	not placed
300R1	8485726Z04																						
GP1280																							
UHF B1	8480587Z01																						
UHF B2	8485677Z01	6.2K	82K	.01uF	1000pF	1000pF	470pF	470pF	470pF	470pF	470pF	470pF	470pF	470pF	470pF	470pF	470pF	470pF	470pF	not placed	not placed	not placed	not placed
VHF	8486062B12	6.2K	82K	.01uF	1000pF	1000pF	470pF	470pF	470pF	470pF	470pF	470pF	470pF	470pF	470pF	470pF	470pF	470pF	470pF	not placed	not placed	not placed	not placed
VHF	8486062B14	6.2K	82K	.01uF	1000pF	1000pF	470pF	470pF	470pF	470pF	470pF	470pF	470pF	470pF	470pF	470pF	470pF	470pF	470pF	not placed	not placed	10K	10K
300R1	8485726Z01	3.6K	47K	not placed	not placed	not placed	100pF	100pF	100pF	100pF	100pF	not placed	not placed	100pF	100pF	100pF	100pF	100pF	100pF	10.0V	10.0V	not placed	not placed
800 MHz	8480641Z03	36K	470K	not placed	not placed	not placed	68pF	68pF	68pF	68pF	68pF	not placed	not placed	68pF	68pF	68pF	68pF	68pF	68pF	10.0V	10.0V	not placed	not placed
UHF B1	8480450Z13																						
UHF B1	8480450Z14	36K	470K	not placed	not placed	not placed	100pF	100pF	100pF	470pF	470pF	not placed	not placed	100pF	100pF	100pF	100pF	100pF	100pF	10.0V	10.0V	10K	10K

ZWG0130110-D

Controller Audio Power Amplifier

Intentionally left blank

3.0 Controller - Set 2 (PCB 8480450Z13/14, 8485641Z06)

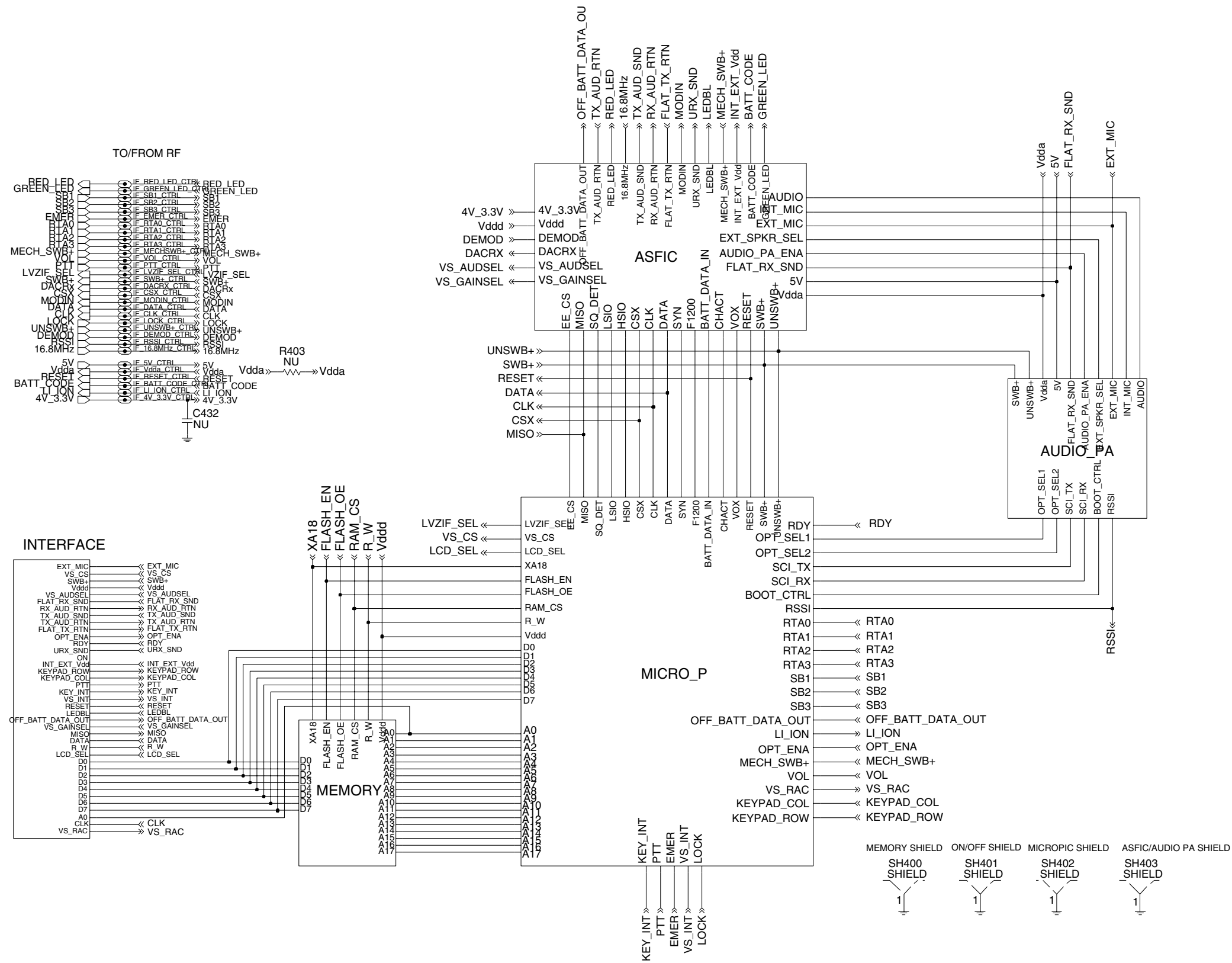

ZMY0130086-B

Overall Controller Schematic

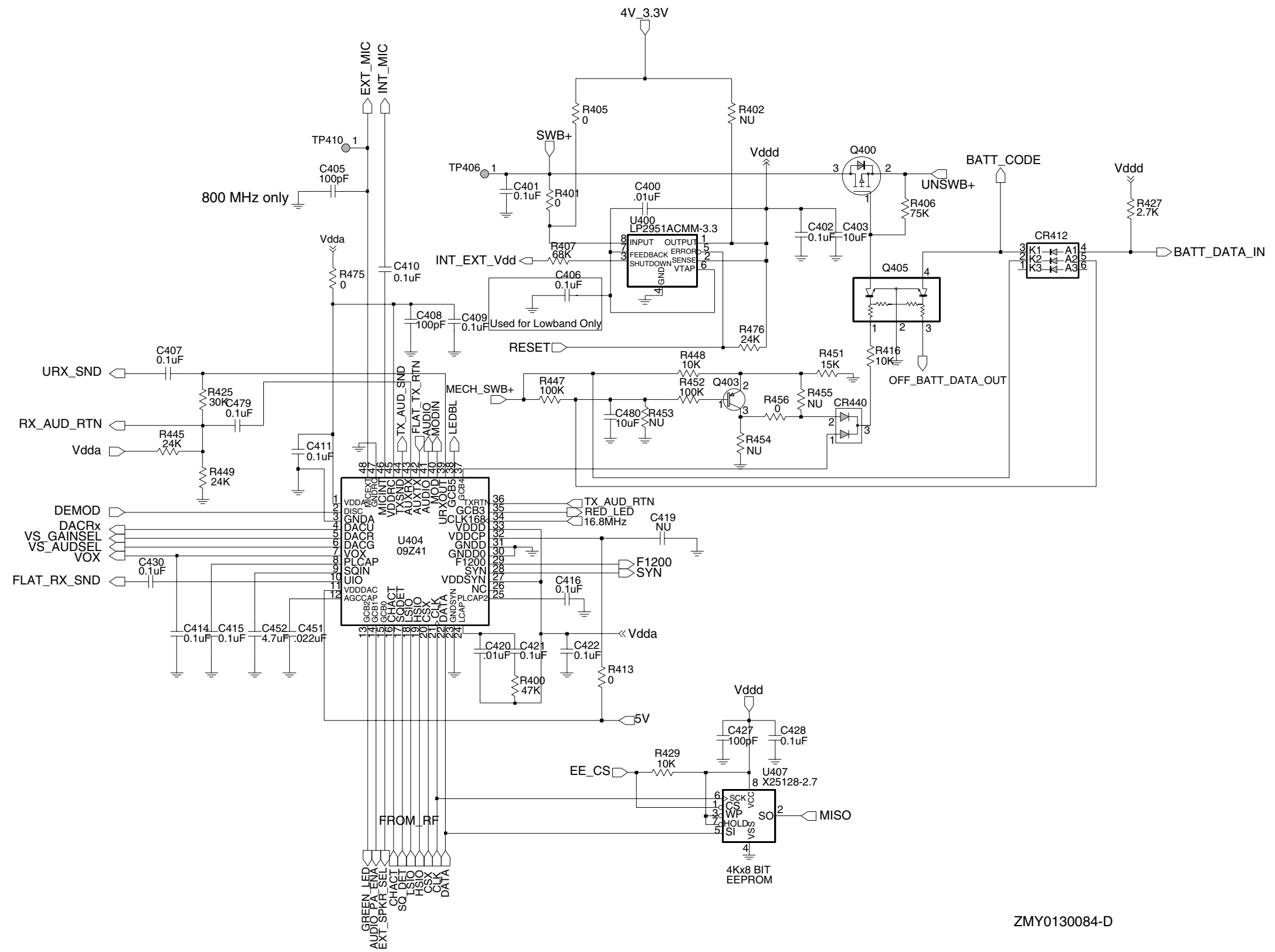

ZMY0130084-D

Controller ASFIC / ON-OFF

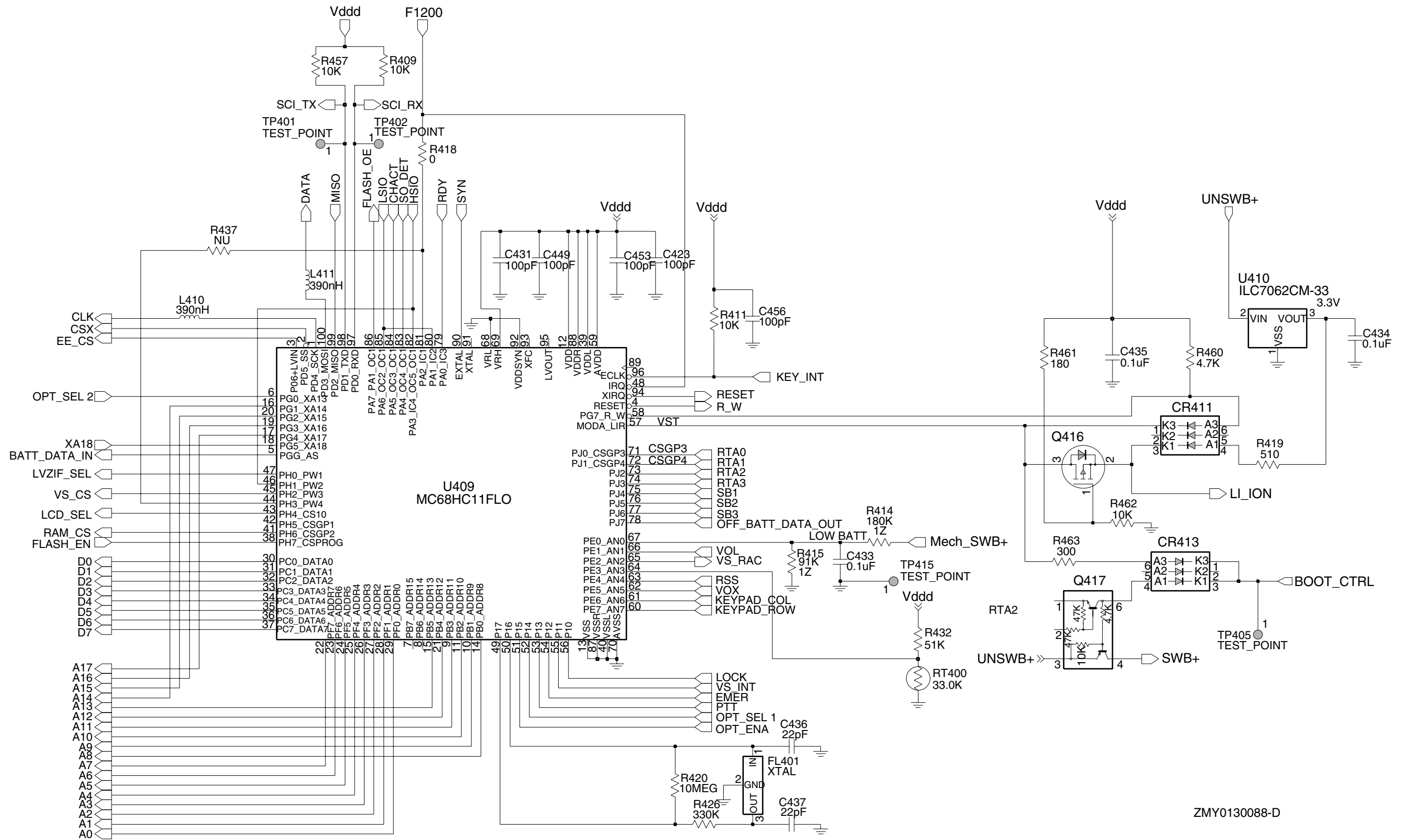

Controller Micro Processor

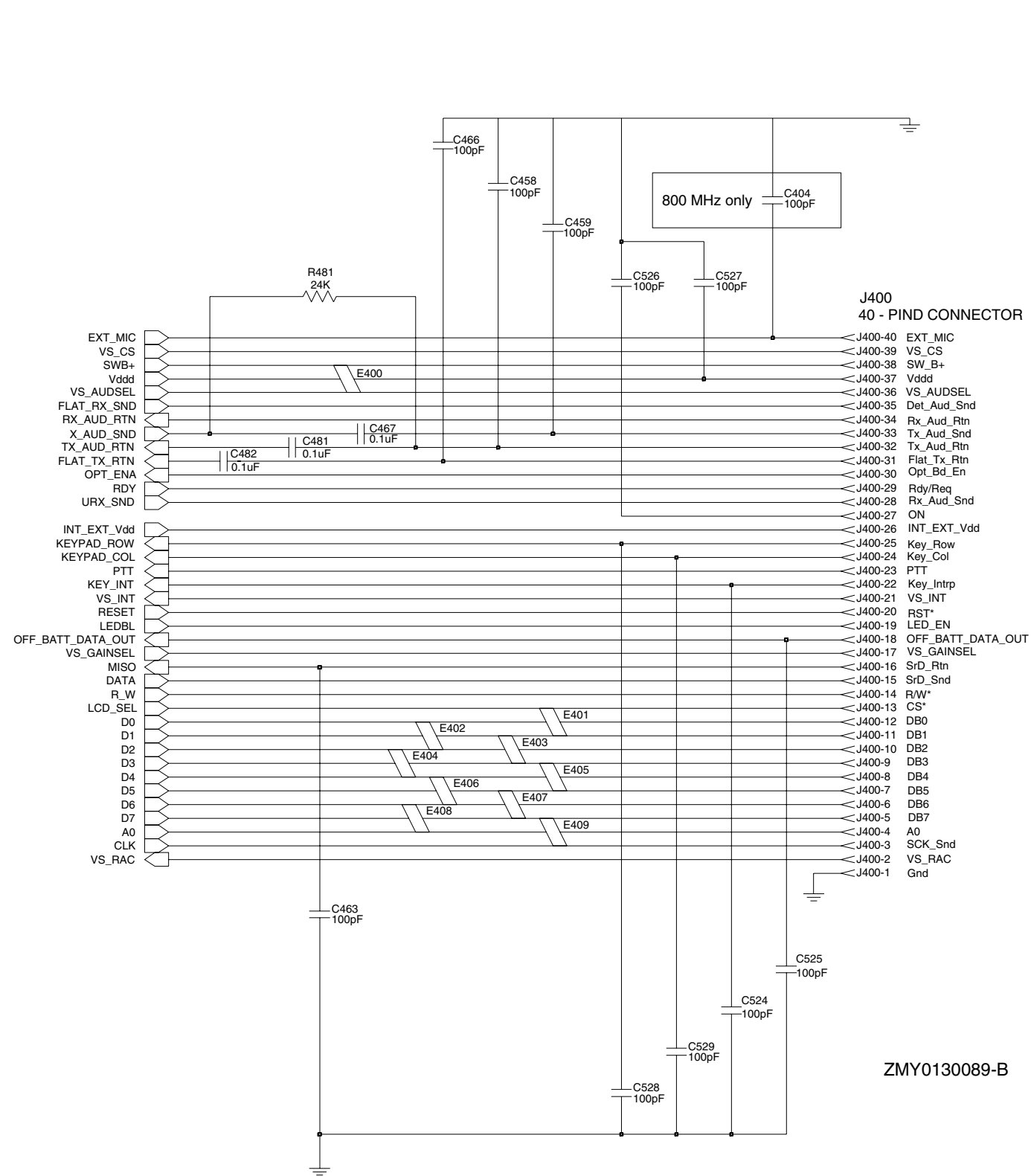

Controller Interface

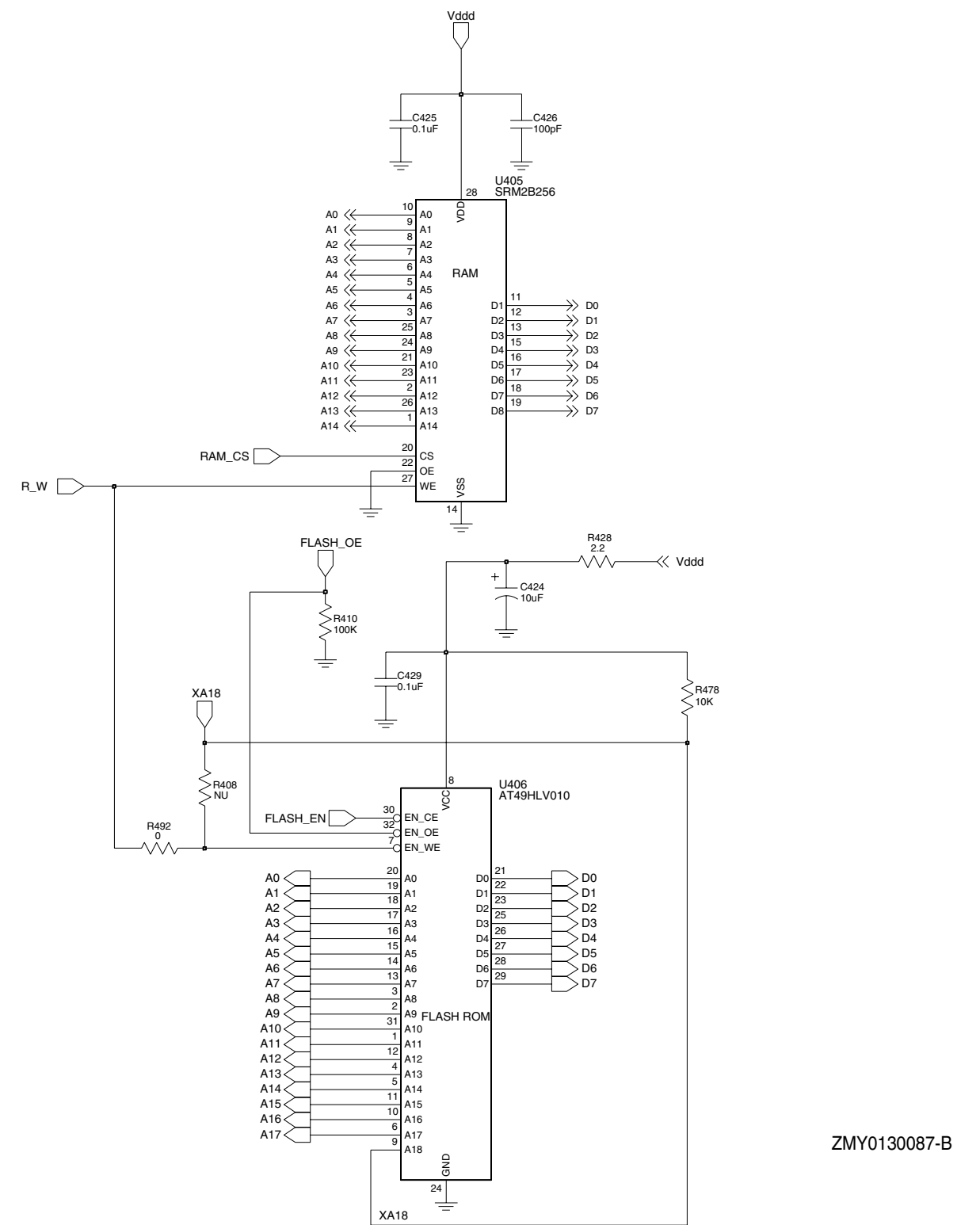

Controller Memory

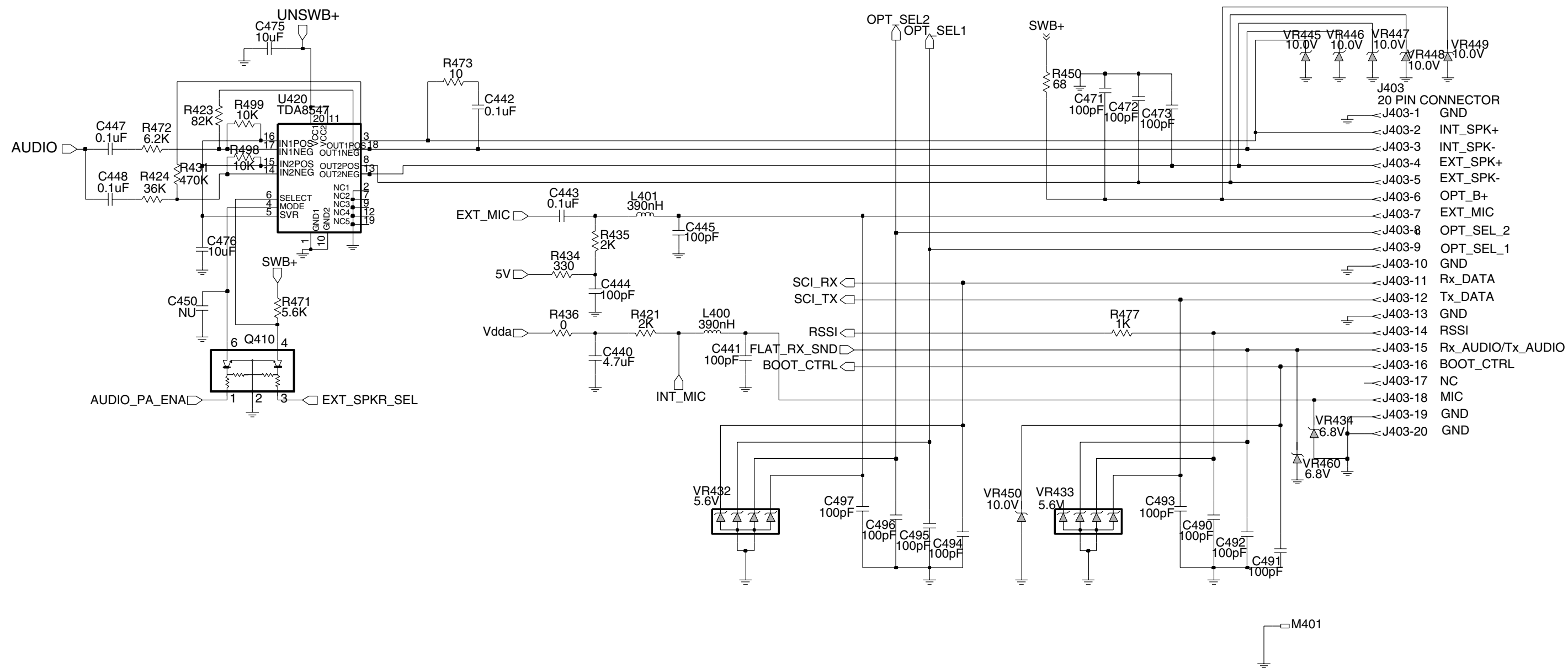

ZMY0130079-D

Controller Audio Power Amplifier

Intentionally left blank

4.0 Controller - Set 3 (PCB 8486458Z03, 8486686Z02)

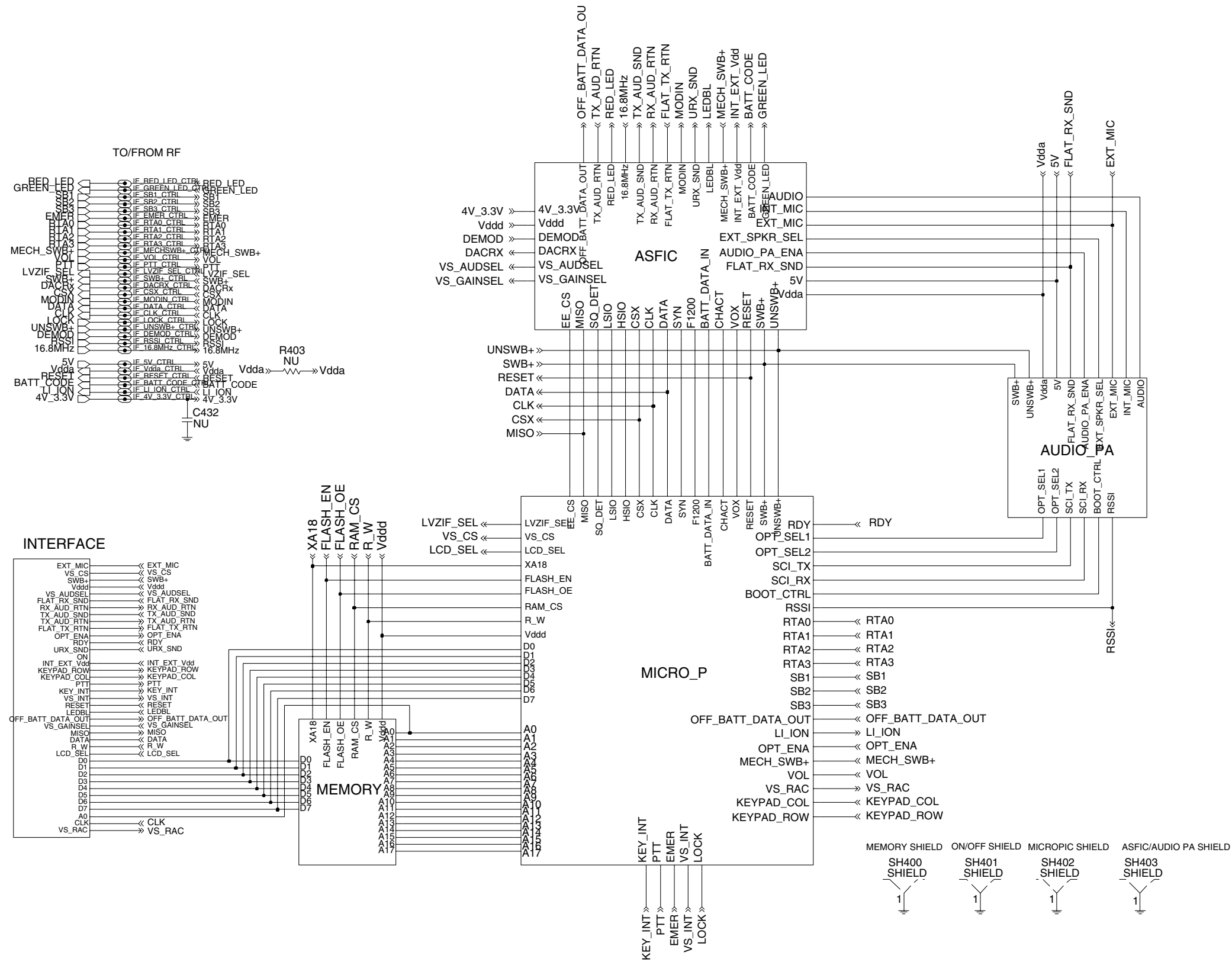

ZMY0130086-B

Overall Controller Schematic

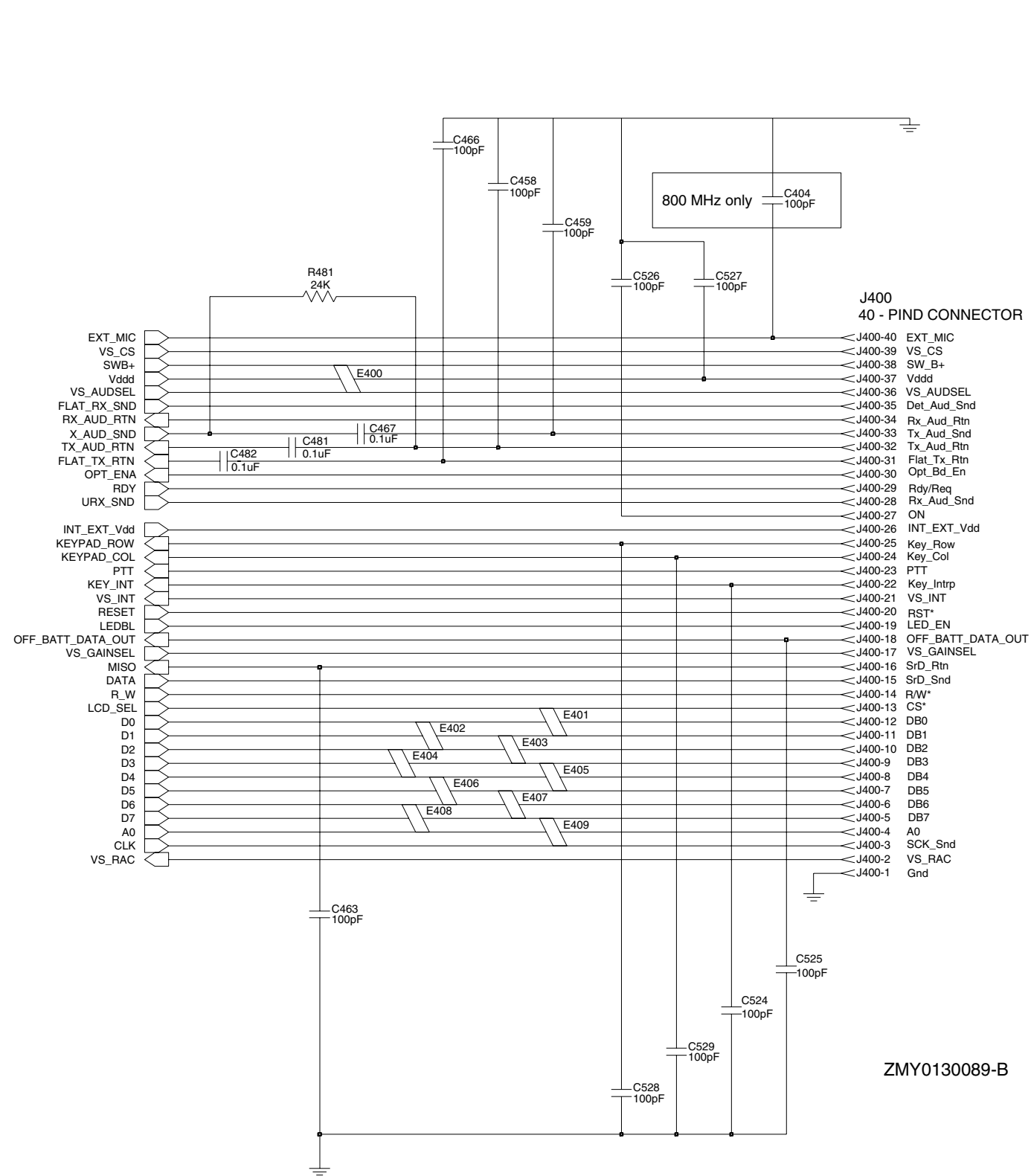

Controller Interface

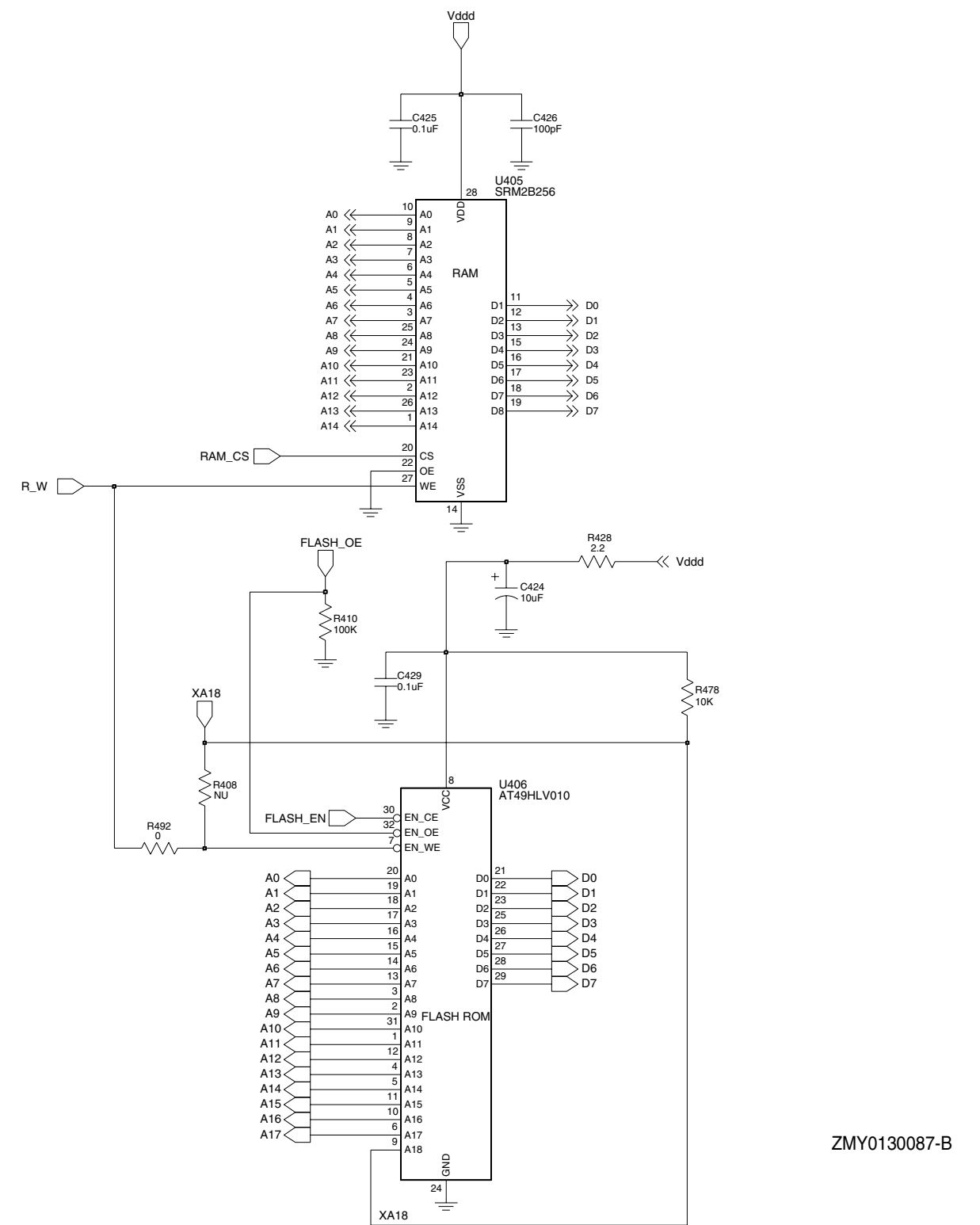

Controller Memory

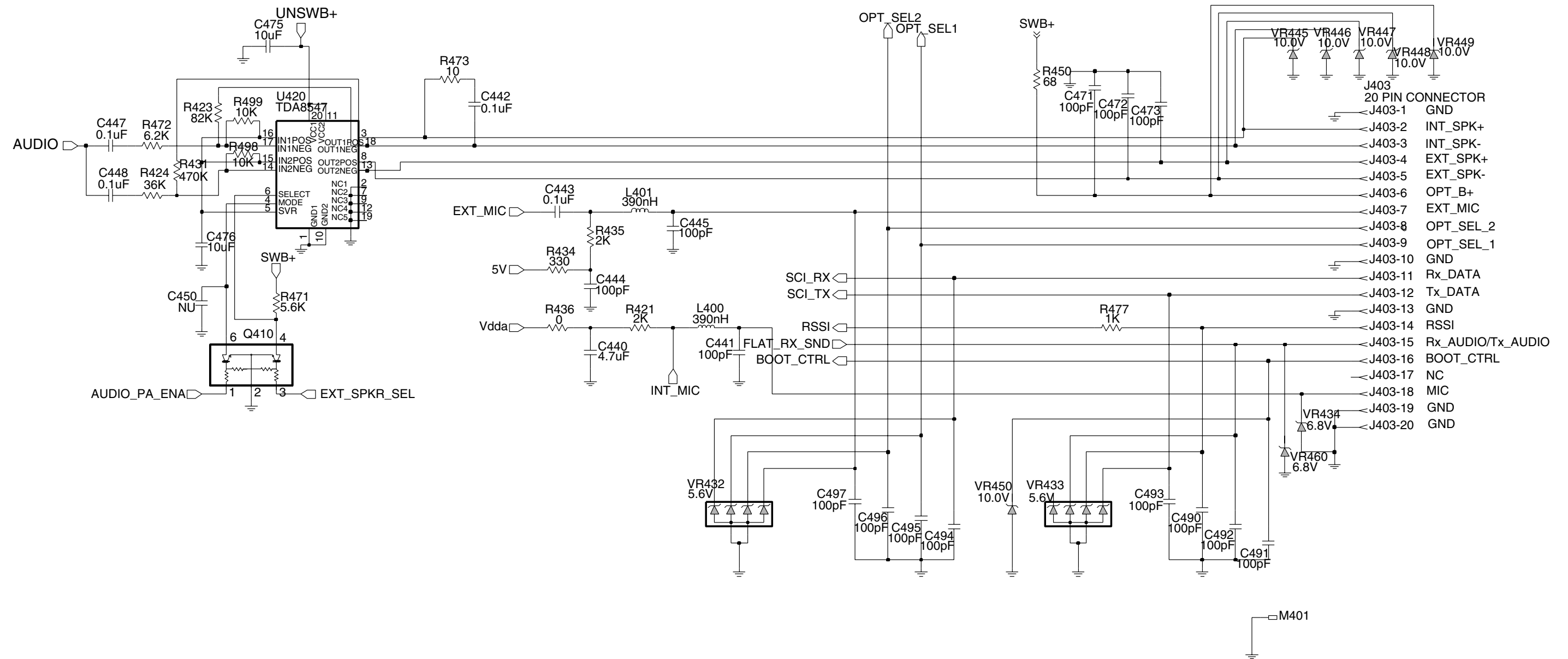

ZMY0130079-D

Controller Audio Power Amplifier

Intentionally left blank