

Owner's Manual & Safety Instructions

Save This Manual Keep this manual for the safety warnings and precautions, assembly, operating, inspection, maintenance and cleaning procedures. Write the product's serial number in the back of the manual near the assembly diagram (or month and year of purchase if product has no number). Keep this manual and the receipt in a safe and dry place for future reference.

17j

**CHICAGO  ELECTRIC
POWER TOOLS**

61969

12" DOUBLE-BEVEL SLIDING COMPOUND MITER SAW WITH LASER GUIDE

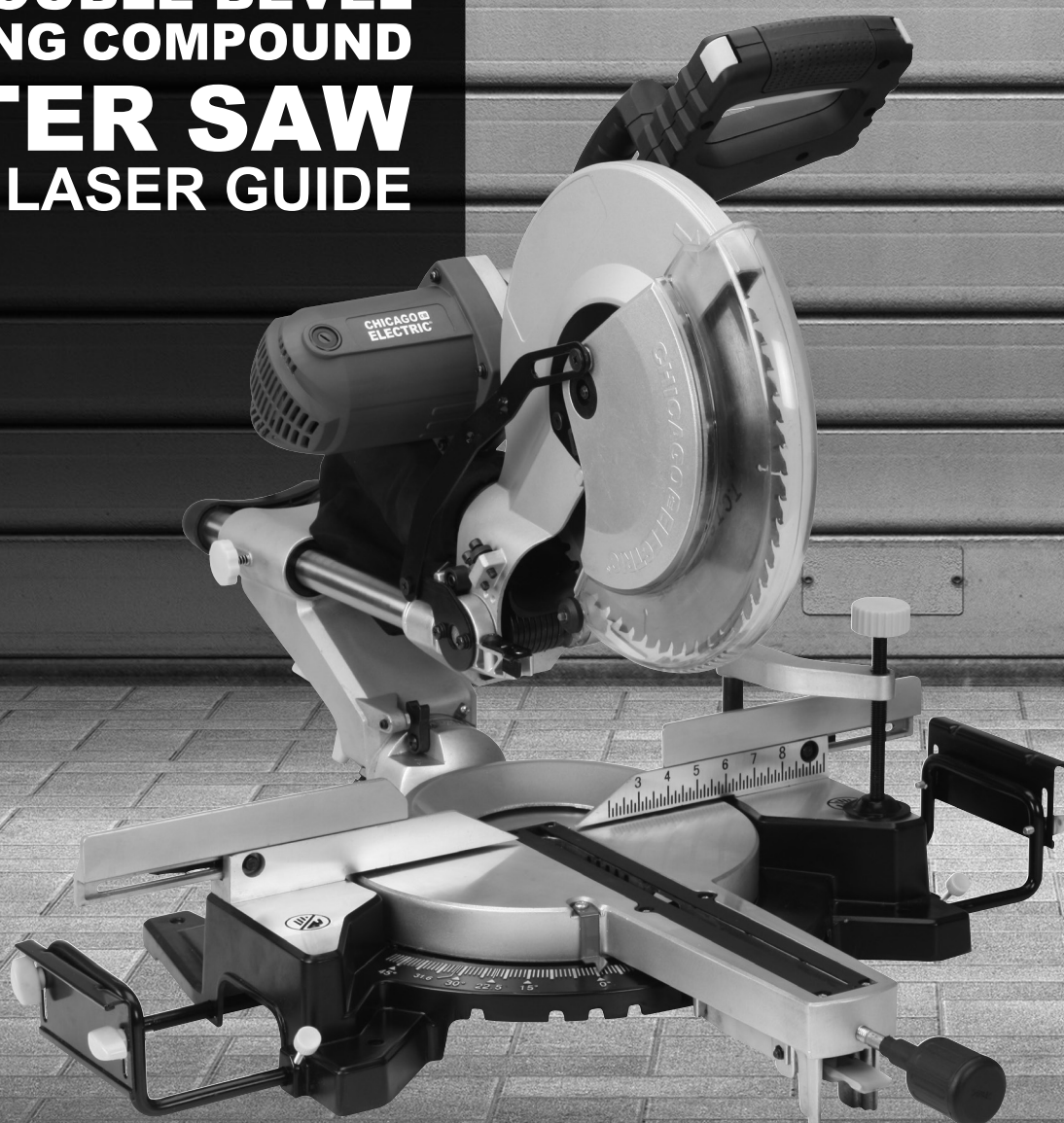

Note: Blade sold separately.

Visit our website at: <http://www.harborfreight.com>

Email our technical support at: productsupport@harborfreight.com

When unpacking, make sure that the product is intact and undamaged. If any parts are missing or broken, please call 1-888-866-5797 as soon as possible.

Copyright © 2013 by Harbor Freight Tools®. All rights reserved.

No portion of this manual or any artwork contained herein may be reproduced in any shape or form without the express written consent of Harbor Freight Tools. Diagrams within this manual may not be drawn proportionally. Due to continuing improvements, actual product may differ slightly from the product described herein.

Tools required for assembly and service may not be included.

⚠ WARNING





**Read this material before using this product.
Failure to do so can result in serious injury.
SAVE THIS MANUAL.**

Table of Contents

Safety	3	Maintenance	14
Specifications	6	Parts List and Diagram	17
Setup	7	Warranty	20
Operation.....	10		

CHICAGO ELECTRIC[®] POWER TOOLS

WARNING SYMBOLS AND DEFINITIONS

	This is the safety alert symbol. It is used to alert you to potential personal injury hazards. Obey all safety messages that follow this symbol to avoid possible injury or death.
	Indicates a hazardous situation which, if not avoided, will result in death or serious injury.
	Indicates a hazardous situation which, if not avoided, could result in death or serious injury.
	Indicates a hazardous situation which, if not avoided, could result in minor or moderate injury.
	Addresses practices not related to personal injury.

IMPORTANT SAFETY INFORMATION

General Tool Safety Warnings

⚠️ WARNING

Read all safety warnings and instructions. Failure to follow the warnings and instructions may result in electric shock, fire and/or serious injury. Save all warnings and instructions for future reference.

1. KEEP GUARDS IN PLACE and in working order.
2. REMOVE ADJUSTING KEYS AND WRENCHES. Form habit of checking to see that keys and adjusting wrenches are removed from tool before turning it on.
3. KEEP WORK AREA CLEAN. Cluttered areas and benches invite accidents.
4. DON'T USE IN DANGEROUS ENVIRONMENT. Don't use power tools in damp or wet locations, or expose them to rain. Keep work area well lit.
5. KEEP CHILDREN AWAY. All visitors should be kept safe distance from work area.
6. MAKE WORKSHOP KID PROOF with padlocks, master switches, or by removing starter keys.
7. DON'T FORCE TOOL. It will do the job better and safer at the rate for which it was designed.
8. USE RIGHT TOOL. Don't force tool or attachment to do a job for which it was not designed.
9. USE PROPER EXTENSION CORD. Make sure your extension cord is in good condition. When using an extension cord, be sure to use one heavy enough to carry the current your product will draw. An undersized cord will cause a drop in line voltage resulting in loss of power and overheating. Table A shows the correct size to use depending on cord length and nameplate ampere rating. If in doubt, use the next heavier gauge. The smaller the gauge number, the heavier the cord.
10. WEAR PROPER APPAREL. Do not wear loose clothing, gloves, neckties, rings, bracelets, or other jewelry which may get caught in moving parts. Nonslip footwear is recommended. Wear protective hair covering to contain long hair.
11. ALWAYS USE SAFETY GLASSES. Also use face or dust mask if cutting operation is dusty. Everyday eyeglasses only have impact resistant lenses, they are NOT safety glasses.
12. SECURE WORK. Use clamps or a vise to hold work when practical. It's safer than using your hand and it frees both hands to operate tool.
13. DON'T OVERREACH. Keep proper footing and balance at all times.
14. MAINTAIN TOOLS WITH CARE. Keep tools sharp and clean for best and safest performance. Follow instructions for lubricating and changing accessories.
15. DISCONNECT TOOLS before servicing; when changing accessories, such as blades, bits, cutters, and the like.
16. REDUCE THE RISK OF UNINTENTIONAL STARTING. Make sure switch is in off position before plugging in.
17. USE RECOMMENDED ACCESSORIES. Consult the owner's manual for recommended accessories. The use of improper accessories may cause risk of injury to persons.
18. NEVER STAND ON TOOL. Serious injury could occur if the tool is tipped or if the cutting tool is unintentionally contacted.
19. CHECK DAMAGED PARTS. Before further use of the tool, a guard or other part that is damaged should be carefully checked to determine that it will operate properly and perform its intended function – check for alignment of moving parts, binding of moving parts, breakage of parts, mounting, and any other conditions that may affect its operation. A guard or other part that is damaged should be properly repaired or replaced.
20. DIRECTION OF FEED. Feed work into a blade or cutter against the direction of rotation of the blade or cutter only.
21. NEVER LEAVE TOOL RUNNING UNATTENDED. TURN POWER OFF. Don't leave tool until it comes to a complete stop.

Table A: RECOMMENDED MINIMUM WIRE GAUGE FOR EXTENSION CORDS (120 VOLT)

NAMEPLATE AMPERES (at full load)	EXTENSION CORD LENGTH			
	25'	50'	100'	150'
0 – 6	18	16	16	14
6.1 – 10	18	16	14	12
10.1 – 12	16	16	14	12
12.1 – 16	14	12	Do not use.	

Grounding Instructions



⚠️ WARNING

TO PREVENT ELECTRIC SHOCK AND DEATH FROM INCORRECT GROUNDING WIRE CONNECTION
READ AND FOLLOW THESE INSTRUCTIONS:

110-120 VAC Double Insulated Tools: Tools with Two Prong Plugs

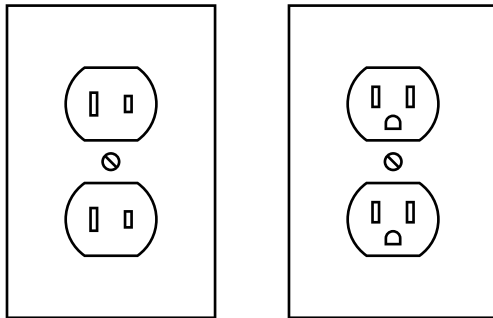

Outlets for 2-Prong Plug

1. To reduce the risk of electric shock, double insulated equipment has a polarized plug (one blade is wider than the other). This plug will fit in a polarized outlet only one way. If the plug does not fit fully in the outlet, reverse the plug. If it still does not fit, contact a qualified electrician to install the proper outlet. Do not change the plug in any way.
2. Double insulated tools may be used in either of the 120 volt outlets shown in the preceding illustration. (See Outlets for 2-Prong Plug.)

Miter Saw Safety Warnings

For Your Own Safety Read Instruction Manual Before Operating Miter Saw

1. Wear eye protection.
2. Keep hands out of path of saw blade.
3. Do not operate saw without guards in place.
4. Do not perform any operation freehand.
5. Never reach around saw blade.
6. Turn off tool and wait for saw blade to stop before moving workpiece or changing settings.
7. Disconnect power before changing blade or servicing.
8. To reduce risk of injury, return carriage to the full rear position after each crosscut operation.
9. Return all guards to original position if any are moved during blade replacement. Check all guards for proper operation after service.
10. The lock down pin is to be used only to lock the head in place for carrying and storage. It is not to be used for any cutting operation.
11. **DANGER! Coasting Cutting Tool Can Be Dangerous – Apply brake immediately to stop cutting tool when the switch is turned off.**
12. **The torque developed during braking may loosen the blade-retaining nut/bolt.** The blade retaining nut/bolt should be checked periodically and tightened if necessary, especially after braking.
13. Always use blades with correct size and shape (diamond versus round) of arbor holes. Blades that do not match the mounting hardware of the saw will run eccentrically, causing loss of control.
14. Never use damaged or incorrect blade washers or bolt. The blade washers and bolt were specially designed for your saw, for optimum performance and safety of operation.
15. Do not use to cut logs, tree limbs, or uneven lumber.
16. Wet lumber, green (unseasoned) lumber, and pressure treated lumber all have an increased potential for kickback and should only be cut with a blade for cutting that lumber type. Wear a NIOSH-approved respirator and have appropriate ventilation whenever cutting pressure treated lumber.
17. Do not use blades made from high-speed steel, abrasive blades, metal-cutting blades or masonry-cutting blades. The guards of this saw are not designed to protect against the failure of such blades.
18. Blades must be rated to at least the maximum speed marked on the tool.
19. **DO NOT OPERATE WITH ANY GUARD DISABLED, DAMAGED, OR REMOVED. Moving guards must move freely and close instantly.**
20. The use of accessories or attachments not recommended by the manufacturer may result in a risk of injury to persons.
21. When servicing use only identical replacement parts.

Miter Saw Safety Warnings (continued)

22. Do not depress the spindle lock when starting or during operation.
23. Only use safety equipment that has been approved by an appropriate standards agency. Unapproved safety equipment may not provide adequate protection. Eye protection must be ANSI-approved and breathing protection must be NIOSH-approved for the specific hazards in the work area.
24. Stay alert, watch what you are doing and use common sense when operating a power tool. Do not use a power tool while you are tired or under the influence of drugs, alcohol or medication. A moment of inattention while operating power tools may result in serious personal injury.
25. Industrial applications must follow OSHA guidelines.
26. Maintain labels and nameplates on the tool. These carry important safety information. If unreadable or missing, contact Harbor Freight Tools for a replacement.
27. Avoid unintentional starting. Prepare to begin work before turning on the tool.
28. People with pacemakers should consult their physician(s) before use. Electromagnetic fields in close proximity to heart pacemaker could cause pacemaker interference or pacemaker failure.
29. The warnings, precautions, and instructions discussed in this instruction manual cannot cover all possible conditions and situations that may occur. It must be understood by the operator that common sense and caution are factors which cannot be built into this product, but must be supplied by the operator.

Vibration Safety

This tool vibrates during use. Repeated or long-term exposure to vibration may cause temporary or permanent physical injury, particularly to the hands, arms and shoulders. To reduce the risk of vibration-related injury:

1. Anyone using vibrating tools regularly or for an extended period should first be examined by a doctor and then have regular medical check-ups to ensure medical problems are not being caused or worsened from use. Pregnant women or people who have impaired blood circulation to the hand, past hand injuries, nervous system disorders, diabetes, or Raynaud's Disease should not use this tool. If you feel any medical or physical symptoms related to vibration (such as tingling, numbness, and white or blue fingers), seek medical advice as soon as possible.
2. Do not smoke during use. Nicotine reduces the blood supply to the hands and fingers, increasing the risk of vibration-related injury.
3. Use tools with the lowest vibration when there is a choice between different processes.
4. Include vibration-free periods each day of work.
5. Grip tool as lightly as possible (while still keeping safe control of it). Let the tool do the work.
6. To reduce vibration, maintain the tool as explained in this manual. If any abnormal vibration occurs, stop use immediately.



SAVE THESE INSTRUCTIONS.

Specifications

Electrical Rating	120VAC / 60Hz / 15A	
Motor No Load Speed	3,800 RPM	
Max. Accessory Diameter	Blade Diameter - 12"	
Arbor	5/8" Round with 1" Adapter	
Cutting Capacities	90° Straight	3-1/2" x 13-3/8"
	45° Miter	3-1/2" x 9-1/2"
	45° Straight Bevel	2-1/8" x 13-3/8"
	45° Compound (L/R)	2-1/8" x 9-1/2"



CAUTION! Use of controls or adjustments or performance of procedures other than those specified herein may result in hazardous radiation exposure.

CAUTION! The use of optical instruments with this product will increase eye hazard.

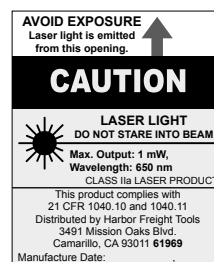

CHICAGO  ELECTRIC[®]
POWER TOOLS

Setup - Before Use:



Read the **ENTIRE IMPORTANT SAFETY INFORMATION** section at the beginning of this manual including all text under subheadings therein before set up or use of this product.

⚠️ WARNING

TO PREVENT SERIOUS INJURY FROM ACCIDENTAL OPERATION:

Turn the Power Switch of the tool off and unplug the tool from its electrical outlet before performing any procedure in this section.

Note: For additional information regarding the parts listed in the following pages, refer to the Assembly Diagram near the end of this manual.

Assembly

1. Insert the ends of the Table Extensions into the holes in the sides of the Base. Tighten the Wing Screws to hold the Extensions in place. The upper edge of the Extensions will be level with the surface of the saw. This provides a wider base for the work material to rest on.
2. Thread the Miter Knob into the end of the table above the Miter Lock until securely in place.
3. Slip the Dust Collection Bag over the Dust Outlet behind the saw.

Mounting

Use the four bolt holes provided in the Base to mount the Miter Saw to a stable support before use. Mounting hardware not included.

CHICAGO  ELECTRIC[®]
POWER TOOLS

Functions

SAFETY

SETUP

OPERATION

MAINTENANCE

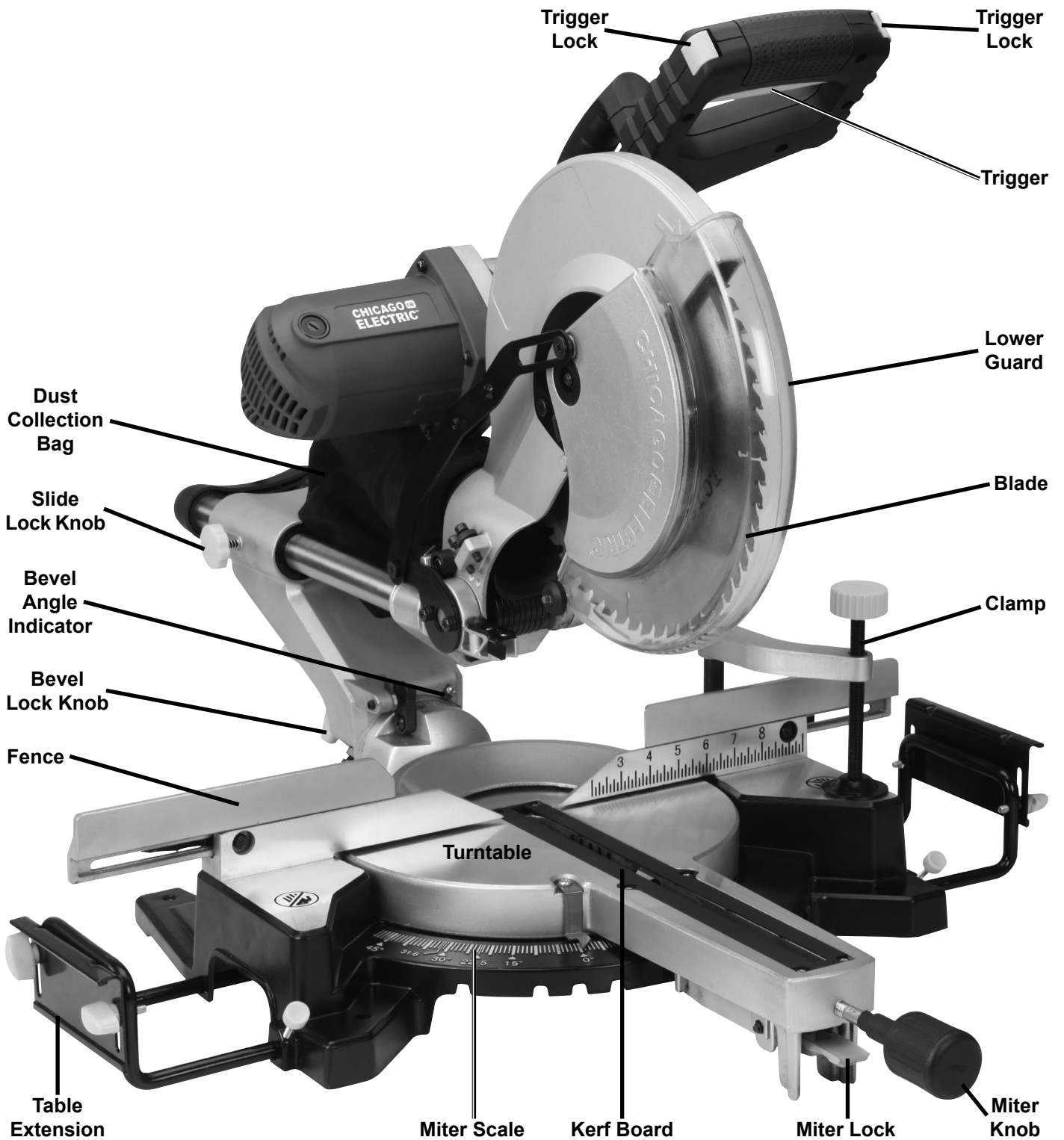

CHICAGO  ELECTRIC[®]
POWER TOOLS

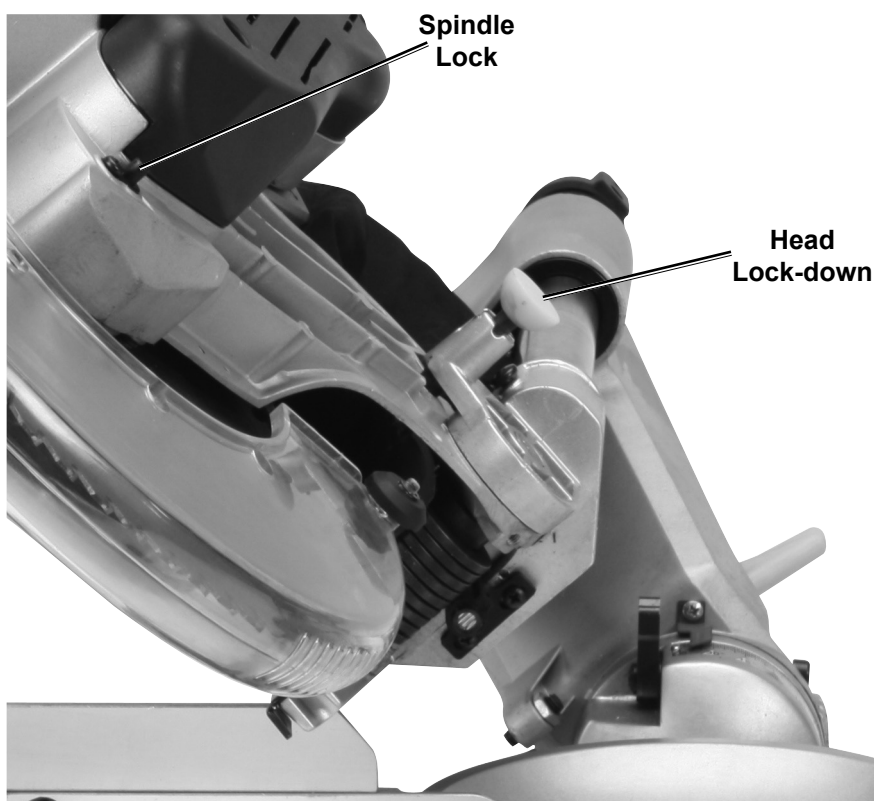

Description of Selected Functions

Head Lock-down:

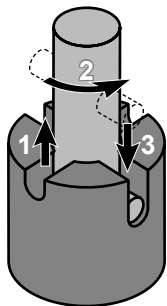

Align pin with **deep groove** to lock cutting head.

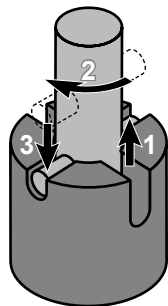

Align pin with **shallow groove** to unlock cutting head.

Guard operation:

When the Handle is lowered, the Lower Guard raises automatically. When the Handle is raised the Lower Guard returns to its safety position. Keep hands clear of the Blade when the Handle is lowered. Do not interfere with the proper movement of the Lower Guard.

Slide Lock Knob:

Tighten this to prevent the cutting head from sliding back and forth for chopping cuts. Loosen this to allow the cutting head to slide.

Note: Additional functions are explained elsewhere in the manual.

CHICAGO  ELECTRIC®
POWER TOOLS

Operating Instructions



Read the **ENTIRE IMPORTANT SAFETY INFORMATION** section at the beginning of this manual including all text under subheadings therein before set up or use of this product.

TOOL SET UP

WARNING

TO PREVENT SERIOUS INJURY FROM ACCIDENTAL OPERATION:

Turn the Power Switch of the tool off and unplug the tool from its electrical outlet before performing any procedure in this section.

TO PREVENT SERIOUS INJURY: DO NOT OPERATE WITH ANY GUARD DISABLED, DAMAGED, OR REMOVED. Moving guards must move freely and close instantly.

Replacing the Blade

Note: Blade sold separately.

1. Unplug the tool from its power source.
2. Raise the Lower Guard (133) out of the way and hold it up.
3. Loosen the Guard Pivot Bolt (193) until it disengages the Guard Pivot Plate (132).
4. Swing the Guard Pivot Plate up and out of the way.
5. Press in the Spindle Lock (150) on the back of the saw's head and hold it in.

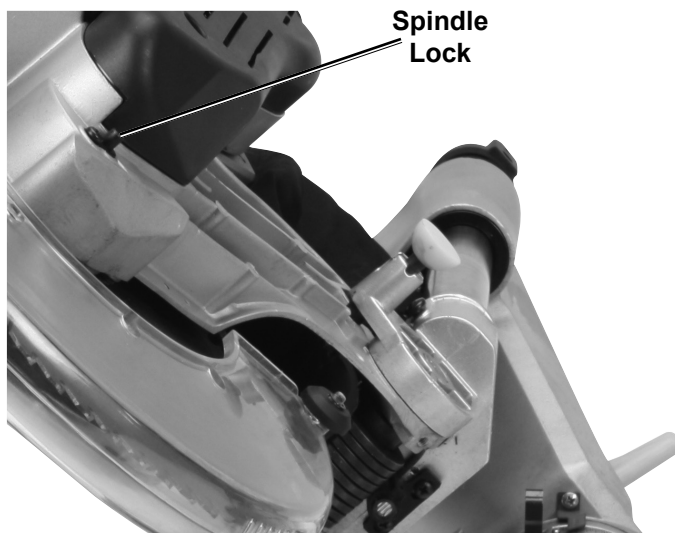

Figure A

6. Remove the Spindle Bolt* (77) and Outer Flange (78), see **Figure B**.
***IMPORTANT: The Spindle Bolt has a left-handed thread and removes by turning CLOCKWISE.**

Note: Make sure the Inner Flange (81) stays in place on the Spindle.

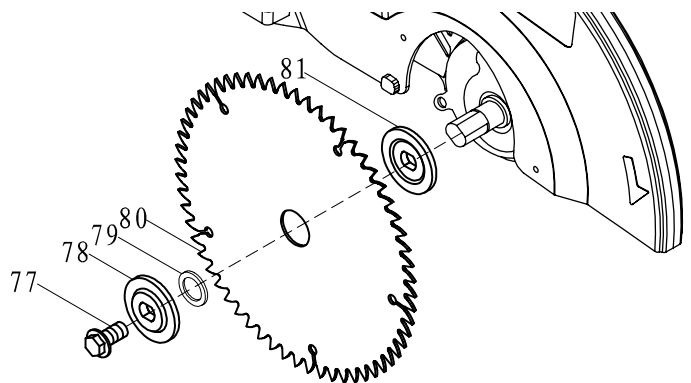

Figure B

7. Remove the Blade (80) and Arbor Insert (79). Place the Arbor Insert into a new Blade and install the new Blade. Make sure that the Blade's rotation arrow points in the same direction as the rotation arrow on the Upper Guard (98).
8. Replace the Outer Flange and Spindle Bolt. Position the cupped side of the Flange against the blade. Hold in the Spindle Lock (150) and wrench tighten the Spindle Bolt by turning it **COUNTERCLOCKWISE**. Release the Spindle Lock.
9. Rotate the Guard Pivot Plate (132) back into place, and secure it with the Guard Pivot Bolt (193).
10. **WARNING! Make sure the Lower Guard (133) operates smoothly and properly protects from the Blade before using the saw.**

Using the Workpiece Extension Supports

1. The Table Extensions are inserted into each side of the Table, and locked in place using the Wing Screws.
2. When properly installed, the upper face of the Table Extensions are level with the Table, and provide a wider support surface for the workpiece.
3. Support the workpiece to be level with the table, and so that after the cut is made the cut off pieces will not fall. Use sawhorses or other supports (not included) to support longer workpieces.
4. If the workpiece is not level, you will make an unintentional bevel cut in the material. If the workpiece is not supported, it will bind the blade and may cause the material to kick back, potentially causing injury.

Adjusting the Miter Angle

A miter cut is one that is at an angle across the horizontal surface of the material. 45° miter cuts to join two pieces in a right angle corner are common. A 30° cut is often used for a scarf joint or to make a chamfered end.

1. Loosen the Miter Knob by turning it approximately 1/4 turn counterclockwise.
2. Press down the Miter Lock to unlock the Table. While holding the Miter Lock down, move the Table to the desired angle.
3. The Miter Angle Indicator will indicate the selected angle. While the Miter Lock is released, the table will lock into place at often used miter angles, including 22.5°, 30°, 45°, and 90° on both left and right sides.
4. Tighten the Miter Knob after adjusting the miter angle.
5. With the Table adjusted to the desired angle, place the workpiece flush against the Fence, secure it with the Clamp and make the cut.

Adjusting the Bevel Angle

A bevel cut is one that is at an angle vertically. Bevel cuts can be used to miter relatively wide and thin material. Bevel cuts can be used in combination with a miter cut to form a compound angle. Compound angle cuts are often used in crown moldings, picture frames and similar trim materials.

1. Loosen the Bevel Lock Knob at the rear of the saw.
2. Move the blade assembly to the desired angle. Read the angle on the Bevel Indicator.
3. Lock the blade assembly into position by rotating the Bevel Lock Knob clockwise. Tighten firmly but do not over-tighten.
4. Make a sample cut in a piece of scrap to confirm that the bevel angle is correct. If it is not, correct the angle before cutting.

WARNING! TO PREVENT SERIOUS INJURY: Adjust both sides of the Fence clear of the Blade's cutting path after making any adjustment to the cutting angle. Move the Blade through its full range of motion to ensure the Fences are clear.

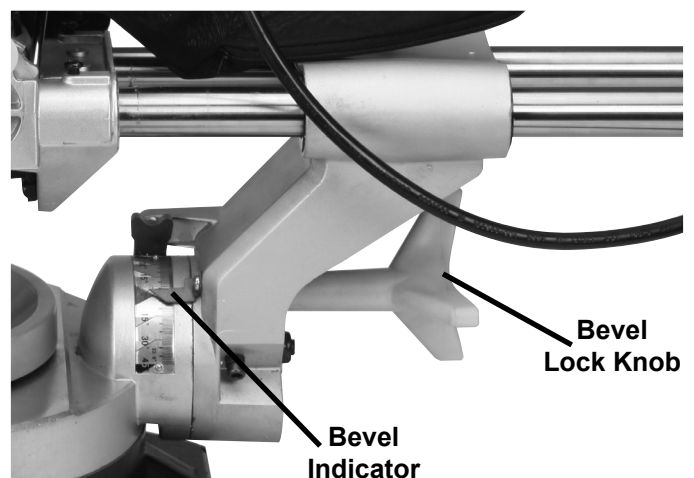

Figure C

Using the Depth Stop

If a kerfing or rabbet cut which does not cut through the workpiece is desired, use the Depth Stop Bolt to control the depth of the cut.

WARNING! Only adjust the front Bolt. The rear Bolt is used to prevent the Blade from cutting the table during normal cutting. Do not adjust the rear Depth Bolt.

1. Unlock the Head Lock-down, see page 9.
2. Raise the Saw Head Assembly.
3. **Push the Depth Stop to the left to use the Depth Stop Bolt setting.**
4. Pull down on the Saw Head to check the current setting.
5. To change the setting, first loosen the knurled Depth Stop Nut on the Depth Stop Bolt. Turn the Depth Stop Bolt clockwise to decrease depth and counterclockwise to increase depth. Tighten the Depth Stop Nut after adjustment.
6. **If needed, push the Depth Stop to the right to temporarily disable it. Make sure the Depth Stop is properly aligned to allow the Bolt to pass through it.**

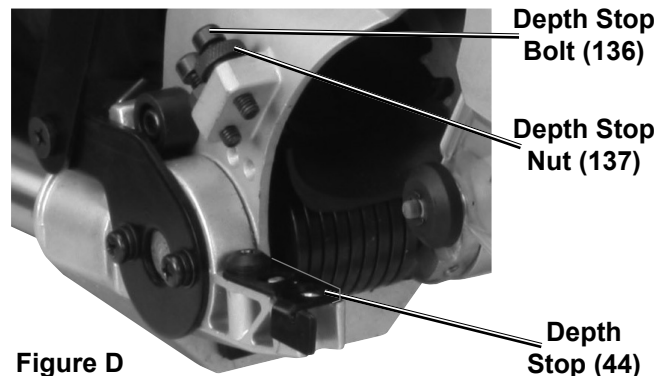

Figure D

Workpiece and Work Area Set Up

1. Designate a work area that is clean and well-lit. The work area must not allow access by children or pets to prevent injury and distraction.
2. Route the power cord along a safe route to reach the work area without creating a tripping hazard or exposing the power cord to possible damage. The power cord must reach the work area with enough extra length to allow free movement while working.
3. Allow room on both left and right of saw for extended workpieces.
4. Use a saw table, saw stand or other means to support the workpiece. Mount the Miter Saw so that the surface is level to the ground, and additional supports provide a surface on the same level as the saw table. If the work surface and any workpiece supports are not level, and on the same level, unwanted bevel angles will appear in the cuts resulting in poor joinery.
5. Secure workpieces to the saw table using the Clamp or other clamping devices (not included). Securing the workpiece will provide safety by preventing kick back and by removing the need to hold workpieces near the blade by hand. Clamping the workpiece will also improve cutting accuracy by preventing the workpiece from moving during the cutting operation.

General Operating Instructions



DANGER!

MITER SAWS CAN QUICKLY AMPUTATE FINGERS IF MISUSED.

Keep hands well clear of cutting area.

1. Unlock the Head Lock-down. Refer to page 9.
2. Make sure all adjustment knobs are tight (Miter Knob, Bevel Lock Knob, Fence and Table Extension Knobs).
3. Blow any sawdust or debris away from the Fence. Place the work material against the Fence.
4. Align the marked location of the cut on the work material with the saw blade.

Note: To prevent your workpiece from being cut too short, align the edge of the blade with your measured mark, keeping the rest of the blade on the waste side of the cut.

5. Hold the work material in place using the Clamp. Ensure that the work material is level and supported securely. Use saw horses or supports if necessary.
6. Grip the Saw Handle, press one of the Trigger Locks with your thumb, and squeeze the Trigger to start the Saw and the laser guide.

Note: If the laser guide line does not line up with the cut line, release Trigger and reposition workpiece before making the cut.

7. With narrow material, press down lightly to cut the workpiece. Press straight down, “chopping” the material. Do not bear down on the material—use light downward pressure. If the material binds the blade, release the Trigger.

8. With wide material, move the Blade across the workpiece while cutting as follows:
 - a. Loosen Slide Lock Knob and pull Saw Head Assembly forward.
 - b. Press down on the Saw Handle.
 - c. Push the Saw Head toward the rear to make the cut. Refer to Figure E.

Do not bear down on the material—use light downward and lateral pressure. If the material binds the blade, release the Trigger.

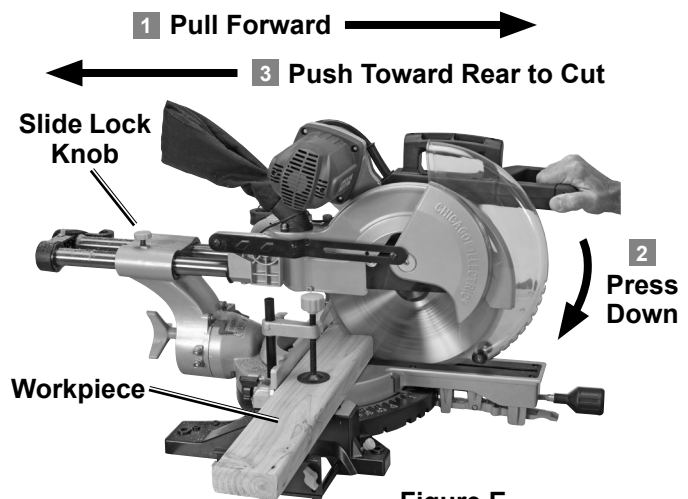

9. When the cut is completed, raise the Saw Head, release the Trigger, wait for the Blade to stop turning, release the Clamp and remove the workpiece from the Saw.
10. To prevent accidents, turn off the tool and disconnect its power supply after use. Clean, then store the tool indoors out of children’s reach.

CHICAGO  ELECTRIC®
POWER TOOLS

Maintenance and Servicing



Procedures not specifically explained in this manual must be performed only by a qualified technician.

WARNING

TO PREVENT SERIOUS INJURY FROM ACCIDENTAL OPERATION:

Turn the Power Switch of the tool off and unplug the tool from its electrical outlet before performing any procedure in this section.

TO PREVENT SERIOUS INJURY FROM TOOL FAILURE:

Do not use damaged equipment. If abnormal noise or vibration occurs, have the problem corrected before further use.

Cleaning, Maintenance, and Lubrication

- BEFORE EACH USE**, inspect the general condition of the tool. Check for:
 - loose hardware,
 - misalignment or binding of moving parts,
 - cracked or broken parts,
 - damaged electrical wiring, and
 - any other condition that may affect its safe operation.
- AFTER USE**, wipe external surfaces of the tool with clean cloth.
- WARNING!** If the supply cord of this power tool is damaged, it must be replaced only by a qualified service technician.

Checking and Calibrating the Fence

The Fence holds the workpiece in a fixed position while the Table and or the blade assembly are adjusted in a miter or bevel angle.

To make accurate cuts, the Fence must be perpendicular (at a 90° angle) to the Saw Blade.

- Before beginning work, make a test cut on scrap material with the Table set at 90°.
- Check the cut with an accurate square. You can also reverse the two pieces, hold the cut ends together, and hold a good straight edge along the side of the pieces.
- If either test reveals that the cut is not a true 90° angle, adjust the Fence before beginning work.

If Fence needs adjustment:

- First unplug the tool.
- Lower the blade assembly and lock it in place using the Locking Pin.
- Lay a carpenter's square on the table with one edge along the blade and the other along the Fence. Any inaccuracy should be visible.
NOTE: The square must contact the surface of the blade, not the teeth, for an accurate reading.

- Remove Nut (9) from the front of the left side fence extension, and remove the left side Extension Lock (15) to allow access to the left side Fence Adjusting Screw (20).



Figure F: Left Fence Adjusting Screw Access

- The Fence is held in place with a Fence Adjusting Screw (20) at each end. Loosen the bolts slightly, and gently tap the Fence into position using a soft mallet. Tighten the Bolts and make another test cut. Repeat the process until the Fence is adjusted accurately.
- Once the Fence is accurately adjusted, tighten the Bolts firmly in place and reinstall the Extension Lock (15). Recheck one last time, then proceed to work.

Calibrating the Miter Table Indicator

After checking or adjusting the fence to confirm that it is at 90° to the Blade, check the accuracy of the Miter Table Angle Indicator.

1. Loosen the screw holding the Angle Indicator in place.
2. Rotate it until the pointer is exactly on 90°.
3. Retighten the screw.

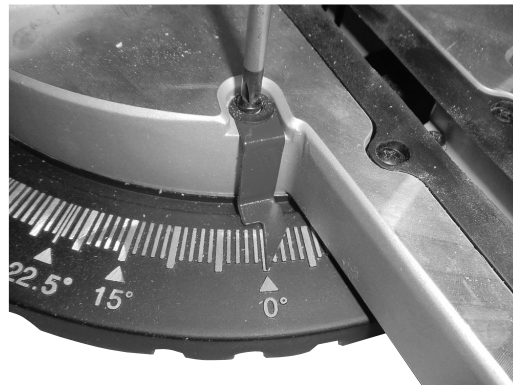

Figure G: Miter Table Angle Indicator Adjustment

Calibrating the Bevel Angle

For making accurate cuts, the Saw Blade must be adjusted to be exactly vertical to the Table.

1. To check the angle, have the blade assembly in its normal upright position. Make a cut on a piece of flat sided, fairly thick scrap material.
2. Check the cut with an accurate square. The cut should be at exactly 90°.
3. Angle can also be checked by rotating one cut-off piece 180° and holding the cut ends together. If the cut is not exactly vertical, the two pieces will form a slight angle.

WARNING! TO PREVENT SERIOUS INJURY: Adjust both sides of the Fence clear of the Blade's cutting path after making any adjustment to the cutting angle. Move the Blade through its full range of motion to ensure the Fences are clear.

4. If necessary, the bevel 0° angle can be corrected by loosening the Zero Stop Lock Nut (66) and adjusting the Zero Stop Screw (65) on the right side under the Bevel Locking Lever. Tighten the Zero Stop Lock Nut (66) after adjustment.
5. Once the bevel angle is adjusted, adjust the Bevel Angle Indicator (49) to read 0° when the Saw Blade is in the vertical position. Loosen the screw holding the Indicator in place, adjust it to be exactly over the 0° mark, then retighten the screw.

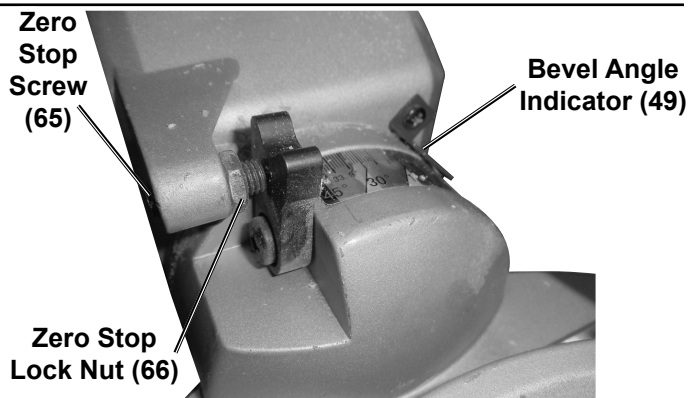

Figure H: Zero Stop Screw and Bevel Angle Indicator

6. To adjust one of the bevel 45° angle stops, loosen the Lock Nut (64) and adjust the Cap Screw (63) on the back near the Bevel Locking Lever. Tighten the Lock Nut (64) after adjustment.

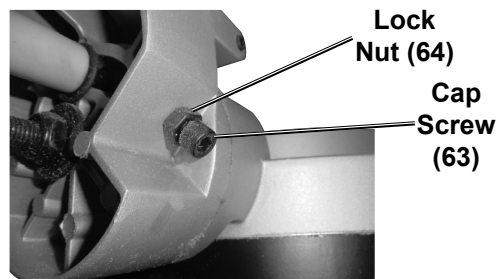

Figure I: 45° Stop Cap Screw

Adjusting or Replacing the Kerf Board

If the Kerf Board becomes damaged it must be replaced.

1. Remove the four screws holding the Kerf Board in place.
2. Install a new Kerf Board. Replace the four screws and tighten them slightly.
2. Adjust the Kerf Board so the right side of the Blade slightly clears the edge of the Kerf Board.
3. Loosen the Bevel Lock and set the Bevel Angle at 45° left.
4. Ensure that the left side of the Blade clears the Kerf Board.
5. Tighten the four screws holding the Kerf Board in place.

To adjust the Kerf Board:

1. Lower the Saw Blade and lock it down with the Locking Pin.

Troubleshooting

Problem	Possible Causes	Likely Solutions
Tool will not start.	<ol style="list-style-type: none"> 1. No power at outlet. 2. Cord not connected. 	<ol style="list-style-type: none"> 1. Check power at outlet. 2. Check that cord is plugged in.
Tool operates sporadically or at low power.	<ol style="list-style-type: none"> 1. Low power supply or improper extension cords. 2. Worn or cracked Carbon Brushes. 	<ol style="list-style-type: none"> 1. Check power supply and power cords. 2. Check Carbon Brushes. Replace if damaged or worn.
Wood burns at ends when cut.	<ol style="list-style-type: none"> 1. Dirty Blade. 2. Material is binding. 	<ol style="list-style-type: none"> 1. Clean Blade using blade cleaner or mineral spirits. 2. Check position of work material on Table. Material must be flat, flush against Fence and supported on ends.
Material frays or chips out.	<ol style="list-style-type: none"> 1. Finished side is down. 2. Blade chipped or dull. 3. Blade inappropriate for material. 4. Material is unsupported. 	<ol style="list-style-type: none"> 1. Keep finished side of material up or facing operator. Bottom and back side are prone to chip out. 2. Check for damaged teeth. Sharpen or replace blade. 3. Check blade manufacturer's recommendations for material being cut. For cross cutting hard wood and for precision cuts use a thin kerf blade with 60 or more teeth. 4. Use a thin piece of scrap material, such as 1/4" plywood, underneath or behind the material to support the edges of the material as it is being cut.
Blade binds, slowing or stopping saw.	<ol style="list-style-type: none"> 1. Material is misaligned on the saw or ends are not supported. 2. Material is wet, contaminated or inappropriate blade is being used. 	<ol style="list-style-type: none"> 1. Material must be flat on table, flush against the fence and supported on both ends. 2. Check condition of material and check compatibility of blade to material.
Blade does not cut completely through workpiece.	<ol style="list-style-type: none"> 1. Depth Stop setting in use. 2. Depth Stop set too shallow. 	<ol style="list-style-type: none"> 1. Move Depth Stop to right to disengage. 2. Adjust Depth Stop Bolt for desired depth of cut.
 <p>Follow all safety precautions whenever diagnosing or servicing the tool. Disconnect power supply before service.</p>		

PLEASE READ THE FOLLOWING CAREFULLY

THE MANUFACTURER AND/OR DISTRIBUTOR HAS PROVIDED THE PARTS LIST AND ASSEMBLY DIAGRAM IN THIS MANUAL AS A REFERENCE TOOL ONLY. NEITHER THE MANUFACTURER OR DISTRIBUTOR MAKES ANY REPRESENTATION OR WARRANTY OF ANY KIND TO THE BUYER THAT HE OR SHE IS QUALIFIED TO MAKE ANY REPAIRS TO THE PRODUCT, OR THAT HE OR SHE IS QUALIFIED TO REPLACE ANY PARTS OF THE PRODUCT. IN FACT, THE MANUFACTURER AND/OR DISTRIBUTOR EXPRESSLY STATES THAT ALL REPAIRS AND PARTS REPLACEMENTS SHOULD BE UNDERTAKEN BY CERTIFIED AND LICENSED TECHNICIANS, AND NOT BY THE BUYER. THE BUYER ASSUMES ALL RISK AND LIABILITY ARISING OUT OF HIS OR HER REPAIRS TO THE ORIGINAL PRODUCT OR REPLACEMENT PARTS THERETO, OR ARISING OUT OF HIS OR HER INSTALLATION OF REPLACEMENT PARTS THERETO.

Record Product's Serial Number Here: _____

Note: If product has no serial number, record month and year of purchase instead.

Note: Some parts are listed and shown for illustration purposes only, and are not available individually as replacement parts.

Parts List and Diagram

Parts List

Part	Description	Qty
1	Base	1
2	Foot	4
3	M8x55 Bolt	1
4	M5x25 Extension Lock Knob	2
5	M5x10 Cross Pan Head Bolt	15
6	Table Extension	2
7	Table Extension Plate	2
8	M6x20 Wing Screw	5
9	M6 Nut	4
10	Ø6 Flat Washer	10
11	Fence	1
12	Square Washer	2
13	Lock Washer	2
14	Lock Screw	2
15	Fence Extension Lock	2
16	Ø5x15.5 Round Pin	2
17	Ø5x9 Round Pin	4
18	Right Fence Extension	1
19	Left Fence Extension	1
20	M8x20 Fence Adjusting Screw	2
21	Ø8 Spring Washer	2
22	Ø8 Flat Washer	2
23	Clamp Board	1
24	M5 Nut	1
25	Miter Lock	1
26	Miter Lock Spring	1
27	Miter Knob	1
28	Miter Knob Washer	1
29	M5x35 Cap Screw	1
30	Kerf Board	1
31	M4x8 Cross Pan Head Bolt	8
32	Turntable	1
33	Miter Indicator	1
34	Ø8 Fender Washer	2
35	M8 Nut	2
36	Bevel Scale	1
37	Ø2x4 Rivet	2

Part	Description	Qty
38	Bevel Hinge	1
39	Lock-down Pin	1
40	Lock-down Spring	1
41	Head Lock-down	1
42	Ø3x16 Spring Round Pin	1
43	M6x10 Cross Pan Head Bolt	4
44	Depth Stop	1
45	Ø8 Wave Washer	2
46	Pan Head Bolt	1
47	Bearing Cover	2
48	M4x10 Cross Pan Head Bolt	1
49	Bevel Angle Indicator	1
50	Turntable Support	1
51	Gear Column	2
52	Angle Block	1
53	M6x16 Non-Standard Screw	1
54	M6x14 Cross Pan Head Bolt	3
55	Ø6 Spring Washer	7
56	M6x10 Cross Bolt	1
57	Connecting Bar Support	1
58	Hinge Pin	1
59	Spring Sleeve	2
60	Torsional Spring	1
61	M10x86 Stud	1
62	M10x50 Stud	1
63	M6x25 Cap Screw	3
64	M6 Lock Nut	3
65	M8x25 Zero Stop Screw	1
66	M8 Zero Stop Lock Nut	1
67	Spring	1
68	M6x25 Slide Lock Knob	1
69	Ø10 Flat Washer	2
70	M10 Nut	1
71	Bevel Lock Knob	1
72	Ø45xØ30x50 Slide Bushing	4
73	Slide Rail	2
74	Ø4 Spring Washer	3

Parts List (continued)

Part	Description	Qty
75	Ø4 Flat Washer	1
76	M10 Thin Nut	1
77	M8x18 Left-handed Spindle Bolt	1
78	Outer Flange	1
79	Arbor Insert	1
80	Blade (sold separately)	0
81	Inner Flange	1
82	M5x20 Cross Pan Head Bolt	6
83	Ø5 Spring Washer	8
84	Ø5 Flat Washer	8
85	Gearbox Cover	1
86	Gasket	1
87	6003 Bearing	1
88	Bearing Retainer	1
89	Connecting Bar Screw	1
90	M4x12 Cross Pan Head Bolt	2
91	Spindle	1
92	Flat Key 4x4x8	1
93	Large Gear	1
94	Ø15 Retaining Ring	1
95	Roller Bearing HK1010	2
96	Guard Label	1
97	M6x10 Set Screw	2
98	Upper Guard	1
99	Upper Guard Bushing	1
100	6001 Bearing	1
101	Flat Key 4x4x20	1
102	Gear Shaft	1
103	Brush Holder	2
104	Carbon Brush	2
105	Brush Holder Cap	2
106	M5x35 Cross Pan Head Bolt	4
107	Motor Housing	1
108	Motor Housing Label	1
109	Stator	1
110	ST4.8x65 Cross Screw	2
111	Seal	1
112	6000 Bearing	1
113	Rotor	1
114	6002 Bearing	1
115	Middle Cover	1
116	M8x25 Set Screw	1
117	Small Pulley	1
118	Lower Guard Roller	2
119	Ø5 Retaining Ring	2
120	Lower Guard Washer	1
121	M6x20 Cap Screw	4
122	Dust Bag	1
123	Dust Port	1
124	Connecting Bar	1
125	Power Cord	1
126	M5x40 Cross Pan Head Bolt	2
127	Lower Guard Panel	1
128	Lower Guard Coil Spring	1
129	Lower Guard Washer	1
130	Rubber Stopper	1
131	M6x7 Flat Head Bolt	1
132	Guard Pivot Plate	1
133	Lower Guard	1
134	Turntable Plate	2

Part	Description	Qty
135	M6x14 Bolt	1
136	M6x35 Bolt	1
137	Depth Adjustment Nut	1
138	Cable Clamp	2
139	Ø6 Flat Washer	1
140	Belt (10PJ560)	1
141	Belt Guard	1
142	M6x16 Cap Screw	3
143	Cover Board	1
144	M6x16 Cap Screw (Left)	1
145	Ø6 Spring Washer (Left)	1
146	Ø6 Thick Flat Washer	1
147	Large Pulley	1
148	Ø28 Retaining Ring	1
149	Spindle Lock Bracket	1
150	Spindle Lock	1
151	Spindle Lock Taper Spring	1
152	ST6x18 Screw	2
153	Handle	1
154	M5x50 Cross Pan Head Bolt	2
155	Upper Handle	1
156	Pin	2
157	Trigger Lock Connector	1
158	Right Trigger Lock	1
159	Left Trigger Lock	1
160	Switch Spring	1
161	Trigger	1
162	Switch	1
163	ST3.9x14 Screw	7
164	ST3.9x10 Screw	2
165	Lower Handle	1
166	Ø5 Teeth Washer	1
167	Terminal	1
168	Cable Clamp	1
169	Grommet	1
170	Slide Rail Cover	1
171	5x40 Roll Pin	2
172	M6 Wing Bolt	1
173	ST4.8x20 Cross Head Screw	1
174	Cable Clamp	2
175	M5x18 Cross Head Bolt	1
176	M5x12 Cross Pan Head Bolt	1
177	Ø5 Spring Washer	1
178	Ø6 Flat Washer	1
179	Clamp Press Plate	1
180	Clamp	1
181	Small Connecting Bar	1
182	M6x20 Wing Screw	1
183	Clamp Locating Bar	1
184	M4x8 Cross Pan Head Bolt	2
185	M4x4 Set Screw	1
186	Laser Seat	1
187	Laser Head	1
188	Wire Clamp	2
189	M4x6 Cross Pan Head Bolt	2
190	Transformer	1
191	ST3.2x6 Cross Screw	2
192	Connector	1
193	M6x10 Guard Pivot Bolt	1

Assembly Diagram

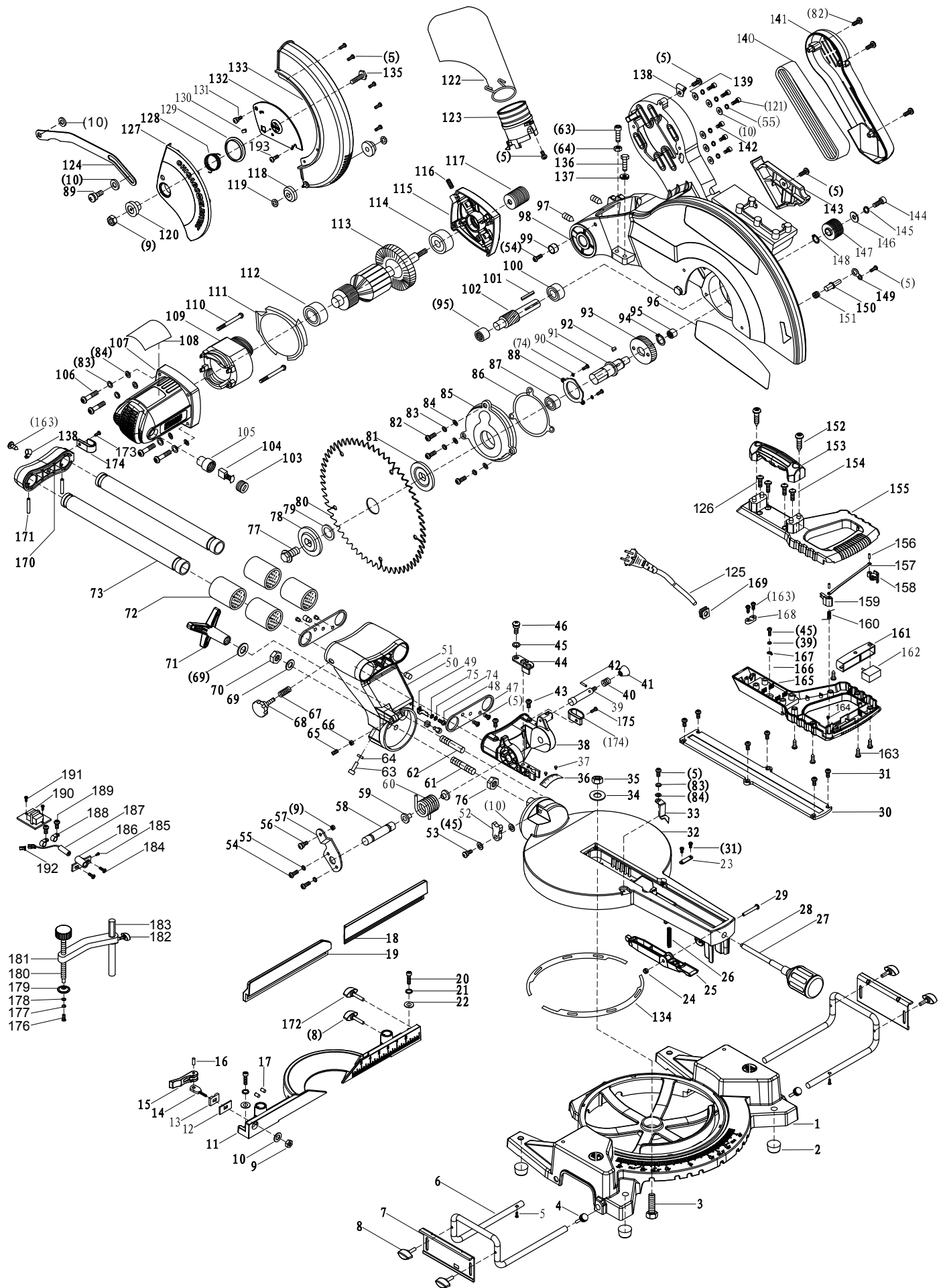

SAFETY

SETUP

OPERATION

MAINTENANCE

Limited 90 Day Warranty

Harbor Freight Tools Co. makes every effort to assure that its products meet high quality and durability standards, and warrants to the original purchaser that this product is free from defects in materials and workmanship for the period of 90 days from the date of purchase. This warranty does not apply to damage due directly or indirectly, to misuse, abuse, negligence or accidents, repairs or alterations outside our facilities, criminal activity, improper installation, normal wear and tear, or to lack of maintenance. We shall in no event be liable for death, injuries to persons or property, or for incidental, contingent, special or consequential damages arising from the use of our product. Some states do not allow the exclusion or limitation of incidental or consequential damages, so the above limitation of exclusion may not apply to you. THIS WARRANTY IS EXPRESSLY IN LIEU OF ALL OTHER WARRANTIES, EXPRESS OR IMPLIED, INCLUDING THE WARRANTIES OF MERCHANTABILITY AND FITNESS.

To take advantage of this warranty, the product or part must be returned to us with transportation charges prepaid. Proof of purchase date and an explanation of the complaint must accompany the merchandise. If our inspection verifies the defect, we will either repair or replace the product at our election or we may elect to refund the purchase price if we cannot readily and quickly provide you with a replacement. We will return repaired products at our expense, but if we determine there is no defect, or that the defect resulted from causes not within the scope of our warranty, then you must bear the cost of returning the product.

This warranty gives you specific legal rights and you may also have other rights which vary from state to state.

CHICAGO  ELECTRIC[®]
POWER TOOLS

3491 Mission Oaks Blvd. • PO Box 6009 • Camarillo, CA 93011 • 1-888-866-5797