

Owner's Manual & Safety Instructions

Save This Manual Keep this manual for the safety warnings and precautions, assembly, operating, inspection, maintenance and cleaning procedures. Write the product's serial number in the back of the manual near the assembly diagram (or month and year of purchase if product has no number). Keep this manual and the receipt in a safe and dry place for future reference.

17e

PREDATOR®
OUTDOOR POWER EQUIPMENT

2500 PSI • 2.4 GPM GAS POWERED PRESSURE WASHER



⚠ DANGER

Using an engine indoors
CAN KILL YOU IN MINUTES.

Engine exhaust contains carbon monoxide.
This is a poison you cannot see or smell.



NEVER use inside
a home or garage,
EVEN IF doors and
windows are open.



Only use **OUTSIDE**
and far away from
windows, doors,
and vents.

Visit our website at: <http://www.harborfreight.com>

Email our technical support at: productsupport@harborfreight.com

Email our engine support at: predator@harborfreight.com

62201

When unpacking, make sure that the product is intact and undamaged. If any parts are missing or broken, please call 1-888-866-5797 as soon as possible.

Copyright© 2014 by Harbor Freight Tools®. All rights reserved.

No portion of this manual or any artwork contained herein may be reproduced in any shape or form without the express written consent of Harbor Freight Tools. Diagrams within this manual may not be drawn proportionally. Due to continuing improvements, actual product may differ slightly from the product described herein. Tools required for assembly and service may not be included.

⚠ WARNING

**Read this material before using this product.
Failure to do so can result in serious injury.
SAVE THIS MANUAL.**

Table of Contents

Specifications	2	Maintenance	16
Safety	3	Troubleshooting.....	20
Setup	7	Parts Lists and Diagrams	24
Operation.....	12	Warranties	30

PREDATOR[®]

OUTDOOR POWER EQUIPMENT

Specifications

Pressure Washer Specifications

Pump	Axial
Drive	Direct
Maximum Pressure	2500 PSI
Flow Rate	2.4 GPM
Hose Length	25'
Wand Length	21"
Nozzles	Quick Connect 0°, 15°, 25°, 40° + Soap Nozzle



Engine Specifications





Displacement		159cc
Engine Type		Vertical Single Cylinder 4-stroke OHV
Cooling System		Forced air cooled
Fuel	Type	87+ octane stabilizer treated unleaded gasoline
	Capacity	0.34 Gallon (1.3 Liter)
Engine Oil	Type SAE	10W-30 above 32° F 5W-30 at 32° F or below
	Capacity	0.5 Quart (0.5 Liter)
Bore x Stroke		65mm x 48mm
Compression Ratio		8.4:1
Rotation viewed from PTO (power takeoff - the output shaft)		Counterclockwise
Spark Plug	Type	Torch [®] F5RTC
	Gap	0.0236" – 0.0314"
Valve Clearance	Intake	0.0039" - 0.0059"
	Exhaust	0.0059" – 0.0078"

The emissions control system for this Engine is warranted for standards set by the U.S. Environmental Protection Agency and by the California Air Resources Board (also known as CARB). For warranty information, refer to the last pages of this manual.

WARNING SYMBOLS AND DEFINITIONS	
	This is the safety alert symbol. It is used to alert you to potential personal injury hazards. Obey all safety messages that follow this symbol to avoid possible injury or death.
⚠ DANGER	Indicates a hazardous situation which, if not avoided, will result in death or serious injury.
⚠ WARNING	Indicates a hazardous situation which, if not avoided, could result in death or serious injury.
⚠ CAUTION	Indicates a hazardous situation which, if not avoided, could result in minor or moderate injury.
NOTICE CAUTION	Addresses practices not related to personal injury.

Symbol Definitions

Symbol	Property or Statement
RPM	Revolutions Per Minute
HP	Horsepower
	WARNING marking concerning Risk of Eye Injury. Wear ANSI-approved safety goggles with side shields.
	Read the manual before set-up and/or use.
	WARNING marking concerning Risk of Hearing Loss. Wear hearing protection.

Symbol	Property or Statement
	WARNING marking concerning Risk of Respiratory Injury. Operate engine OUTSIDE and far away from windows, doors, and vents.
	WARNING marking concerning Risk of Fire while handling fuel. Do not smoke while handling fuel.
	WARNING marking concerning Risk of Fire. Do not refuel while operating. Keep flammable objects away from engine.
	WARNING marking concerning Risk of Injection. Do not direct water stream/nozzle at body.

IMPORTANT SAFETY INSTRUCTIONS

 **WARNING! Read all instructions.**
Failure to follow all instructions listed below may result in fire, serious injury and/or DEATH.
 The warnings and precautions discussed in this manual cannot cover all possible conditions and situations that may occur. It must be understood by the operator that common sense and caution are factors which cannot be built into this product, but must be supplied by the operator.

SAVE THESE INSTRUCTIONS

Set Up Precautions

1. Gasoline fuel and fumes are flammable, and potentially explosive. Use proper fuel storage and handling procedures. Do not store fuel or other flammable materials nearby.
2. Have multiple ABC class fire extinguishers nearby.
3. Operation of this equipment may create sparks that can start fires around dry vegetation. A spark arrestor may be required. The operator should contact local fire agencies for laws or regulations relating to fire prevention requirements.
4. Set up and use only on a flat, level, well-ventilated surface.
5. The work area should have adequate drainage to reduce the possibility of a fall due to slippery surfaces.
6. Wear ANSI-approved safety goggles, heavy-duty work gloves, and dust mask/respirator during set up.
7. Use only lubricants and fuel recommended in the Specifications chart of this manual.
8. Only use cold water or pressure washer detergent in this tool. Do not use caustic materials, solvents, flammable materials, or detergents not designed for pressure washers. Use of any such material can cause injury, or damage this tool or personal property.
9. Do not dry run this product. Dry running will cause serious damage to the seals. Make sure the water supply used for the Pressure Washer is not dirty or sandy.
10. Prior to starting the Pressure Washer in cold weather, check all of the parts of the unit to make sure ice has not formed. Do not store the unit anywhere that the temperature will fall below 32° F (0° C).

Operating Precautions

1.  **CARBON MONOXIDE HAZARD**
Using an engine indoors CAN KILL YOU IN MINUTES.
Engine exhaust contains carbon monoxide. This is a poison you cannot see or smell.

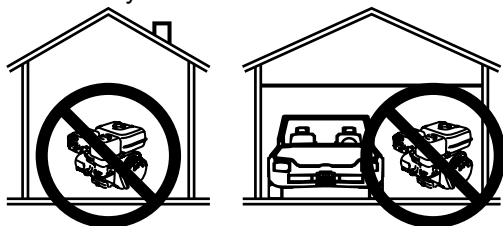

NEVER use inside a home or garage, EVEN IF doors and windows are open.

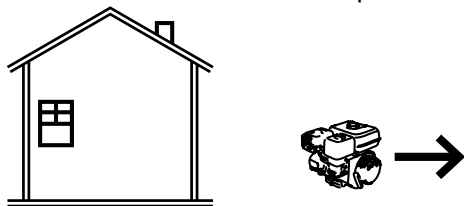

Only use OUTSIDE and far away from windows, doors, and vents.

2. Keep children away from the equipment, especially while it is operating.
3. Parts of the Pressure Washer, especially exhaust system components, get very hot during use. Stay clear of hot parts.
4.  **Injection Hazard!** The high pressure water jet produced by this tool can cut skin or cause injury to hands or eyes. Do not allow spray to strike you and do not spray toward people or animals. Do not spray the tool itself or any electrical wiring/receptacle.

5. Do not carry the spray handle with your finger on the trigger, whether engine is operating or not.
6. In case of an emergency during use, immediately release the trigger on the spray handle, turn the engine off and then shut off gas supply to the engine. Do not set the spray handle down without turning off the engine.
7. This Pressure Washer is intended for outdoor residential use only.
8. The high pressure water flow can damage the work surface if not used properly. Always test the spray in an open area first.
9. When dispensing detergent, apply the detergent to the cleaning area at low pressure only. Detergent dispensing only works when the spray wand is in the low-pressure position.
10. Keep all spectators at least six feet from the Engine during operation.
11. Fire Hazard! Do not fill fuel tank while engine is running. Do not operate if gasoline has been spilled. Clean spilled gasoline before starting engine. Do not operate near pilot light or open flame.
12. Do not touch engine during use. Let engine cool down after use.
13. Do not leave the equipment unattended when it is running. Turn off the equipment (and remove safety keys, if available) before leaving the work area.
14. The equipment can produce high noise levels. Prolonged exposure to noise levels above 85 dBA is hazardous to hearing. Wear ear protection when operating the equipment or when working nearby while it is operating.
15. Wear ANSI-approved safety glasses and hearing protection during use.

Operating Precautions (continued)

16. People with pacemakers should consult their physician(s) before use. Electromagnetic fields in close proximity to a heart pacemaker could cause pacemaker interference or pacemaker failure. Caution is necessary when near the engine's magneto or recoil starter.
17. Use only accessories that are recommended by Harbor Freight Tools for your model. Accessories that may be suitable for one piece of equipment may become hazardous when used on another piece of equipment.
18. Do not operate in explosive atmospheres, such as in the presence of flammable liquids, gases, or dust. Gasoline-powered engines may ignite the dust or fumes.
19. Stay alert, watch what you are doing and use common sense when operating this piece of equipment. Do not use while tired or under the influence of drugs, alcohol or medication.
20. Do not overreach. Keep proper footing and balance at all times. This enables better control of the equipment in unexpected situations.
21. Use this equipment with both hands only. Using equipment with only one hand can easily result in loss of control.
22. Dress properly. Do not wear loose clothing or jewelry. Keep hair, clothing and gloves away from moving parts. Loose clothes, jewelry or long hair can be caught in moving parts.
23. Do not cover the engine or equipment during operation.
24. Keep the equipment, engine, and surrounding area clean at all times.
25. Do not smoke, or allow sparks, flames, or other sources of ignition around the equipment, especially when refuelling.
26. Use the equipment, accessories, etc., in accordance with these instructions and in the manner intended for the particular type of equipment, taking into account the working conditions and the work to be performed. Use of the equipment for operations different from those intended could result in a hazardous situation.
27. Do not operate the equipment with known leaks in the engine's fuel system.
28. When spills of fuel or oil occur, they must be cleaned up immediately. Dispose of fluids and cleaning materials as per any local, state, or federal codes and regulations. Store oil rags in a bottom-ventilated, covered, metal container.
29. Keep hands and feet away from moving parts. Do not reach over or across equipment while operating.
30. Before use, check for misalignment or binding of moving parts, breakage of parts, and any other condition that may affect the equipment's operation. **If damaged, have the equipment serviced before using.** Many accidents are caused by poorly maintained equipment.
31. Use the correct equipment for the application. Do not modify the equipment and do not use the equipment for a purpose for which it is not intended.

Vibration Precautions

- This tool vibrates during use. Repeated or long-term exposure to vibration may cause temporary or permanent physical injury, particularly to the hands, arms and shoulders. To reduce the risk of vibration-related injury:
1. Anyone using vibrating tools regularly or for an extended period should first be examined by a doctor and then have regular medical check-ups to ensure medical problems are not being caused or worsened from use. Pregnant women or people who have impaired blood circulation to the hand, past hand injuries, nervous system disorders, diabetes, or Raynaud's Disease should not use this tool. If you feel any medical or physical symptoms related to vibration (such as tingling, numbness, and white or blue fingers), seek medical advice as soon as possible.
 2. Do not smoke during use. Nicotine reduces the blood supply to the hands and fingers, increasing the risk of vibration-related injury.
 3. Wear suitable gloves to reduce the vibration effects on the user.
 4. Use tools with the lowest vibration when there is a choice between different processes.
 5. Include vibration-free periods each day of work.
 6. Grip tool as lightly as possible (while still keeping safe control of it). Let the tool do the work.
 7. To reduce vibration, maintain the tool as explained in this manual. If any abnormal vibration occurs, stop use immediately.

Service Precautions

SAFETY

1. **Before service, maintenance, or cleaning:**
 - a. **Turn the engine switch to its “OFF” position.**
 - b. **Allow the engine to completely cool.**
 - c. **Then, remove the spark plug cap from the spark plug.**
2. Keep all safety guards in place and in proper working order. Safety guards include muffler, air cleaner, mechanical guards, and heat shields, among other guards.
3. **Do not alter or adjust any part of the equipment or its engine that is sealed by the manufacturer or distributor. Only a qualified service technician may adjust parts that may increase or decrease governed engine speed.**

SETUP

4. Wear ANSI-approved safety goggles, heavy-duty work gloves, and dust mask/respirator during service.
5. Keep the high pressure hose connected to the pressure washer and spray gun while the system is pressurized. Disconnecting the pressure hose while the unit is pressurized is dangerous, and may cause injury.
6. Do not allow the high pressure hose to come in contact with any hot part of the unit. The hose might be damaged, possibly causing it to burst or leak under high pressure.
7. Maintain labels and nameplates on the equipment. These carry important information. If unreadable or missing, contact Harbor Freight Tools for a replacement.

OPERATION

8. If water is leaking out of the Pressure Washer immediately turn off the unit. Unplug the Pressure Washer, and discharge all pressure before tightening fittings or having repair work done by a qualified technician.
9. When the engine is running, do not allow the Pressure Washer to remain idle for more than two minutes. If allowed to remain idle, the water in the unit will heat up, possibly causing damage to the Pressure Washer.

MAINTENANCE

10. Have the equipment serviced by a qualified repair person using only identical replacement parts. This will ensure that the safety of the equipment is maintained. Do not attempt any service or maintenance procedures not explained in this manual or any procedures that you are uncertain about your ability to perform safely or correctly.
11. Store equipment out of the reach of children.
12. Follow scheduled engine and equipment maintenance.

Refueling:

1. Do not refill the fuel tank while the engine is running or hot.
2. Do not smoke, or allow sparks, flames, or other sources of ignition around the equipment, especially when refuelling.
3. **Do not fill fuel tank to the top.** Leave a little room for the fuel to expand as needed. **TO PREVENT FUEL LEAKAGE AND FIRE HAZARD, do not fill fuel above the bottom of fuel strainer.**

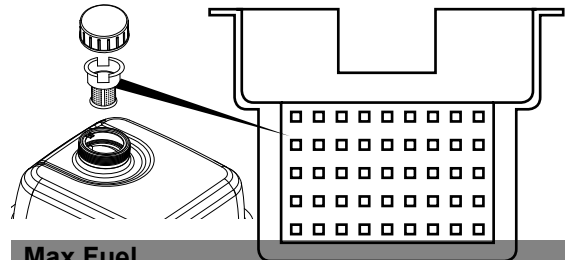

**Max Fuel
DO NOT OVERFILL!**

4. Refuel in a well-ventilated area only.
5. Wipe up any spilled fuel and allow excess to evaporate before starting engine. **To prevent FIRE, do not start the engine while the smell of fuel hangs in the air.**



SAVE THESE INSTRUCTIONS.

Set Up



Read the **ENTIRE IMPORTANT SAFETY INFORMATION** section at the beginning of this manual including all text under subheadings therein before set up or use of this product.

WARNING

TO PREVENT SERIOUS INJURY:

Operate only with proper spark arrestor installed.



Operation of this equipment may create sparks that can start fires around dry vegetation. A spark arrestor may be required. The operator should contact local fire agencies for laws or regulations relating to fire prevention requirements.

TO PREVENT SERIOUS INJURY FROM ACCIDENTAL STARTING: Turn the Power Switch of the equipment to its “OFF” position, wait for the engine to cool, and unplug the spark plug wire(s) before assembling or making any adjustments to the equipment.

Note: For additional information regarding the parts listed in the following pages, refer to the Assembly Diagrams near the end of this manual.

Assembly

1. Attach the Handle (5) onto the Frame (13) with the Handle Knobs (12).
2. Attach the Spray Gun Holder (3) to the Handle with a Knob (4).
3. Attach the Hose Hanger (7) to the Handle with a Knob (4).
4. Attach the two Wand Holders (14) to the Frame using Bolts (20).

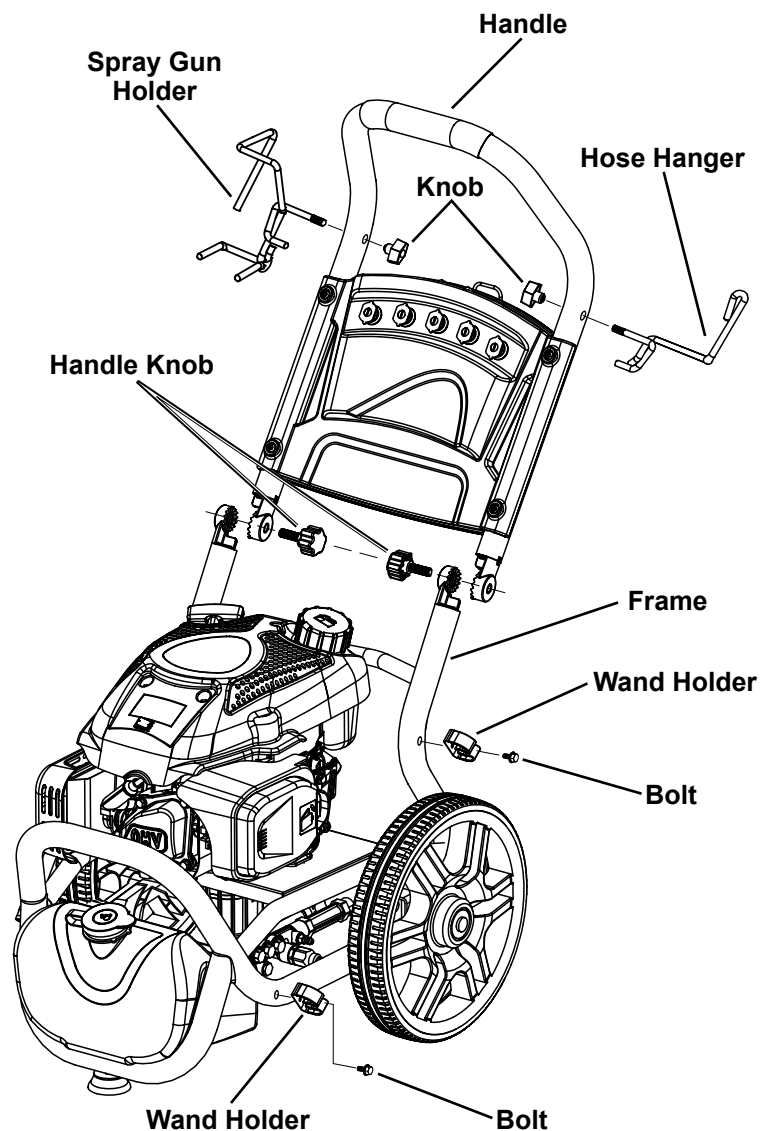

Figure A

Assembly (continued)

SAFETY

5. Connect the Pressure Hose (15) to the outlet fitting on the Pump (32) and firmly hand-tighten the nut. See Figure B.

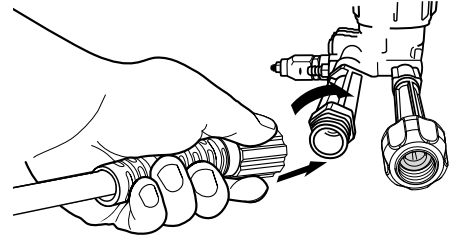

Figure B

6. Connect the Pressure Hose to the handle of the Spray Gun (2) and firmly hand-tighten the nut. See Figure C.

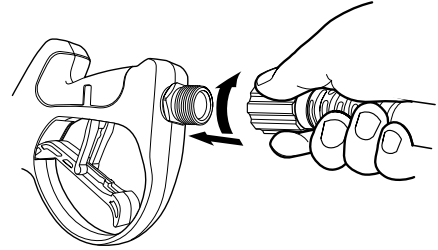

Figure C

SETUP

7. Remove the protective cap on the Wand (1) inlet. Insert the Wand into the Spray Gun tip and firmly hand-tighten the nut. See Figure D.

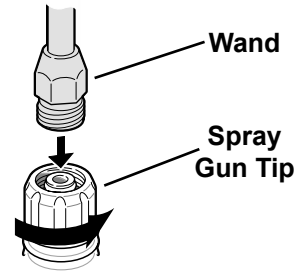

Figure D

OPERATION

8. Attach the Nozzle (8) to the Wand by pulling back the quick connect collar and pushing the Nozzle onto the end of the Wand. Make sure the quick connect collar locks the Nozzle in place. See Figure E.

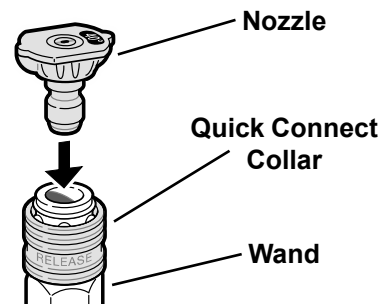

Figure E

MAINTENANCE

9. Connect the water supply hose to the water inlet connection on the Pump (32) and hand-tighten the Inlet Fitting. See Figure F. The water source must be able to provide a minimum of five gallons of clean, cold water per minute at 20 PSI. Only use a 5/8" inner diameter (or larger) hose that is rated to meet this capacity.

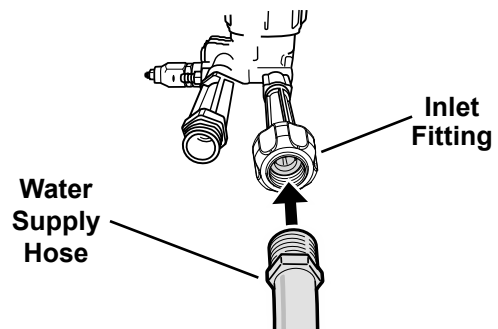
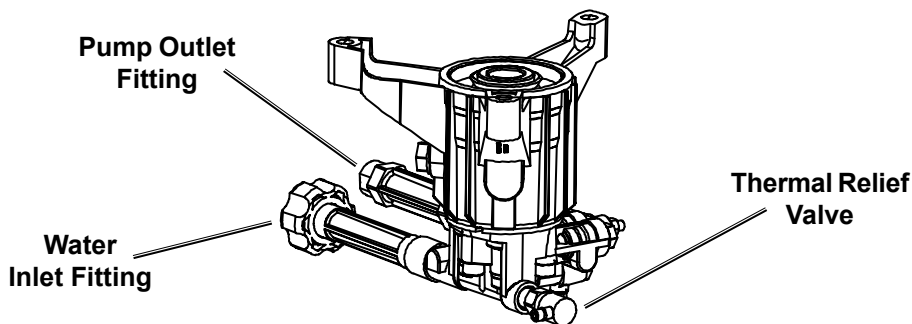
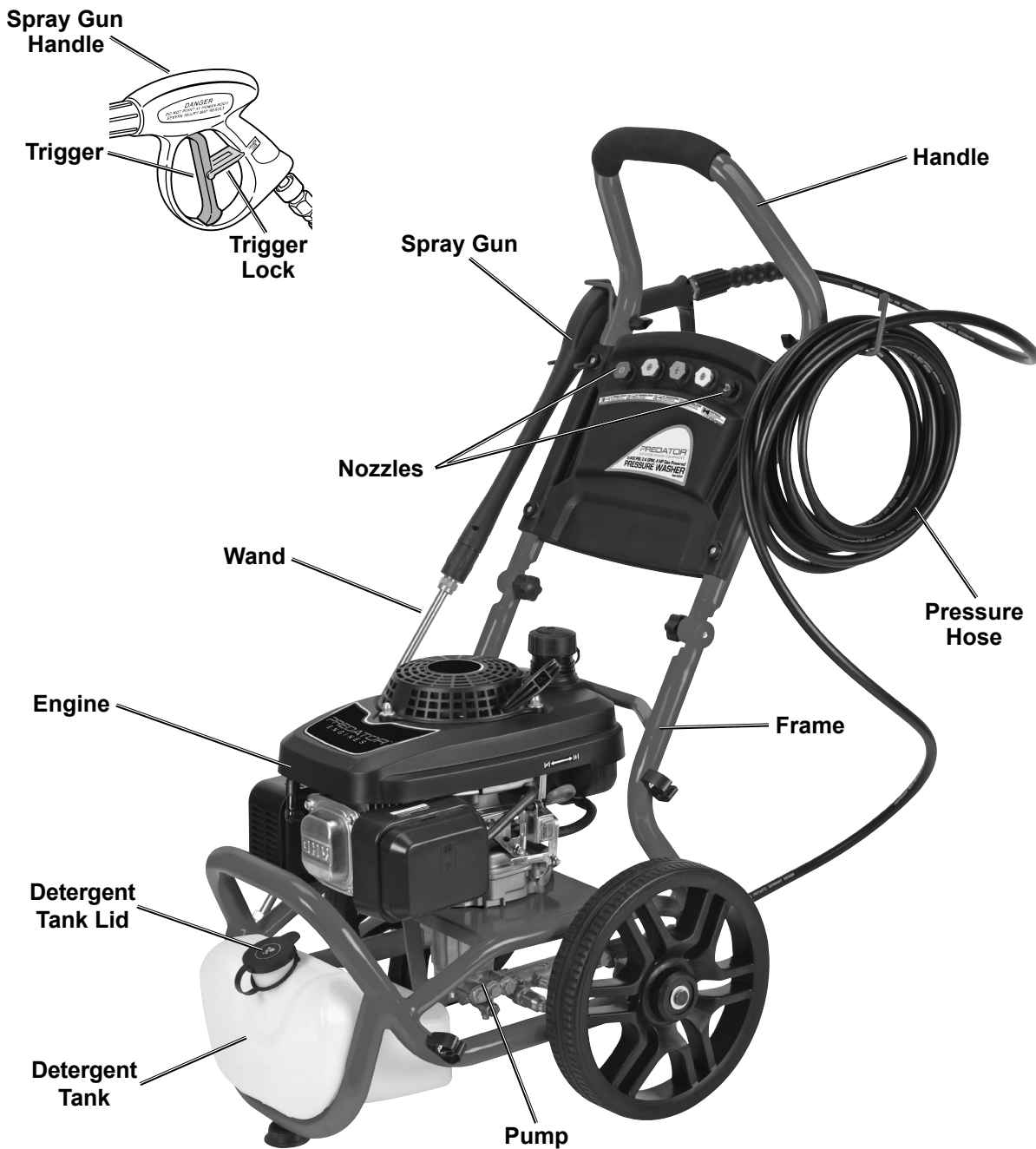

Figure F

Components and Controls



SAFETY

SETUP

OPERATION

MAINTENANCE

Engine Controls

SAFETY

SETUP

OPERATION

MAINTENANCE

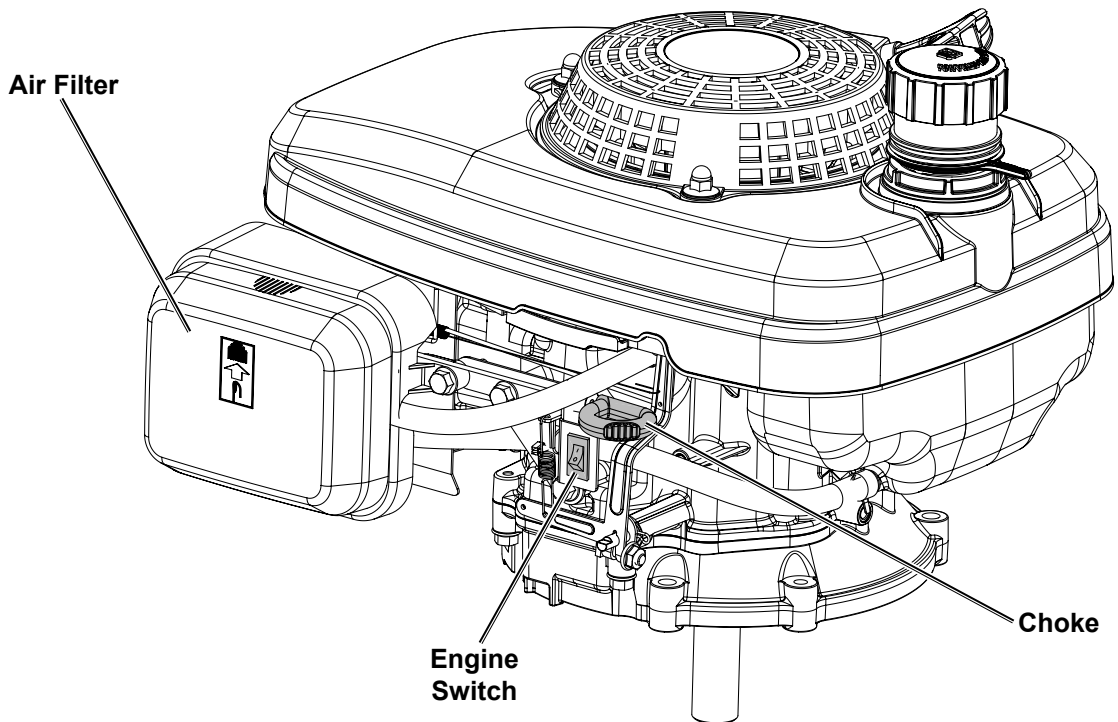
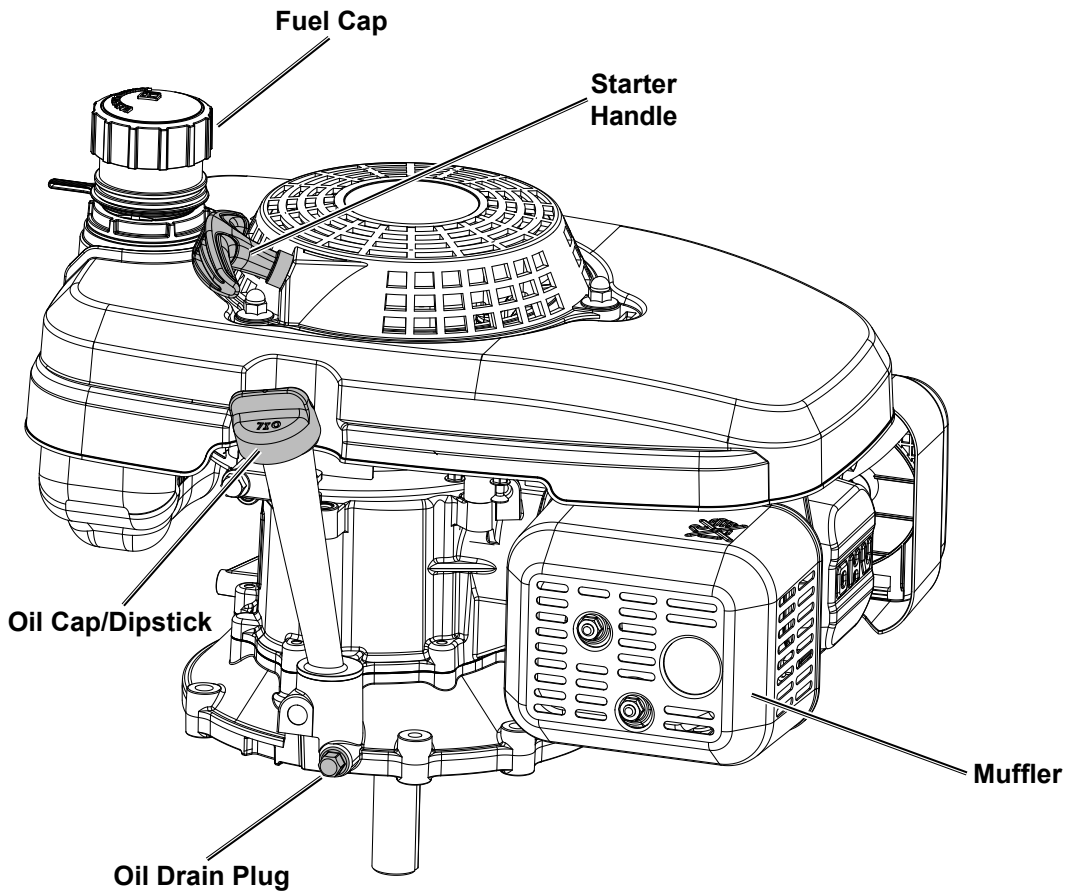

High Altitude Operation Above 7000 feet

⚠️WARNING! TO PREVENT SERIOUS INJURY FROM FIRE:

Follow instructions in a well-ventilated area away from ignition sources.

If the engine is hot from use, shut the engine off and wait for it to cool before proceeding. Do not smoke.

NOTICE: Warranty void if necessary adjustments are not made for high altitude use.

At high altitudes, the engine's carburetor, governor (if so equipped), and any other parts that control the fuel-air ratio will need to be adjusted by a qualified mechanic to allow efficient high-altitude use and to prevent damage to the engine and any other devices used with this product. The fuel system on this engine may be influenced by operation at higher altitudes. Proper operation can be ensured by installing an altitude kit at altitudes higher than 7000 ft. above sea level. At elevations above 8000 ft, the engine may experience decreased performance, even with the proper main jet. Operating this engine without the proper altitude kit installed may increase the engine's emissions and decrease fuel economy and performance. The kit should be installed by a qualified mechanic.

1. Turn off the engine.
2. Place a bowl under the fuel cup to catch any spilled fuel.

CAUTION! Carburetor bowl may have gas in it which will leak upon removing the bolt.

3. Unthread the bolt holding the fuel cup.
4. Remove the bolt, Bolt Seal, fuel cup, Fuel Cup Seal and Main Jet from the body of the carburetor assembly. A carburetor screwdriver (not included) is needed to remove and install the Main Jet.

Note: The mixing tube is held in place by the Main Jet and might fall out when it is removed. If it falls out, replace it in the same orientation before replacing the Main Jet.

5. Replace the Main Jet with the replacement Main Jet (part 1a).

Note: The Fuel Cup Seal and Bolt Seal may be damaged during removal and should be replaced with the new ones from the kit.

6. Replace the Fuel Cup Seal (3a), fuel cup, Bolt Seal (2a), and bolt. Tighten in place.

NOTICE: Do not cross thread bolt when tightening.

Finger tighten first and then use a wrench to make sure the bolt is properly threaded.

7. Wipe up any spilled fuel and allow excess to evaporate before starting engine. To prevent FIRE, do not start the engine while the smell of fuel hangs in the air.

High Altitude Kit Parts List - A

Part	Description	Qty
1a	Main Jet 7000-8000 ft.	1
2a	Bolt Seal	1
3a	Fuel Cup Seal	1

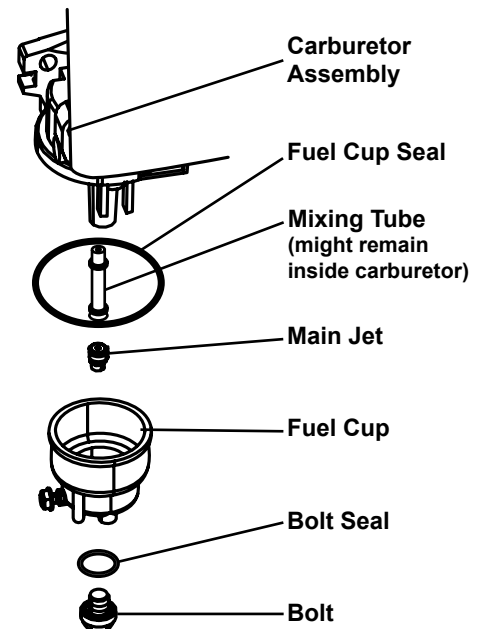

Operation



Read the **ENTIRE IMPORTANT SAFETY INFORMATION** section at the beginning of this manual including all text under subheadings therein before set up or use of this product.

Pre-Start Checks

Inspect engine and equipment looking for damaged, loose, and missing parts before set up and starting. If any problems are found, do not use equipment until fixed properly.

Checking and Filling Engine Oil

NOTICE: Your Warranty is VOID if the engine's crankcase is not properly filled with oil before each use. Before each use, check the oil level. Engine will not start with low or no engine oil.

1. Make sure the engine is stopped and is level.
2. Close the Fuel Valve.
3. Clean the top of the Dipstick and the area around it. Remove the Dipstick by turning it counterclockwise, and wipe it off with a clean, lint free rag.
4. Reinsert the Dipstick completely by turning it clockwise, then remove it again to check the oil level. The oil level should be up to the full level, the top of the crosshatched area on the dipstick as shown in Figure G.

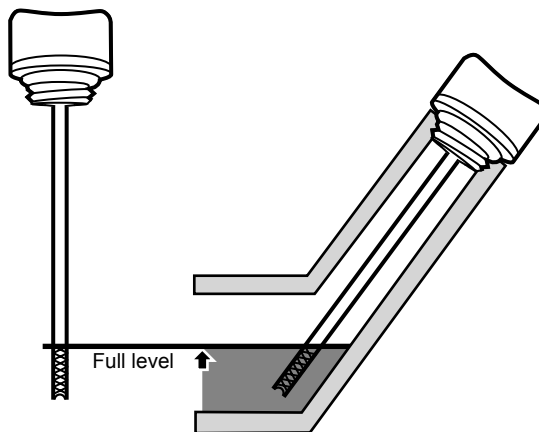

Figure G

5. If the oil level is at or below the low mark add the appropriate type of oil until the oil level is at the proper level. SAE 10W-30 oil is recommended for general use. (The SAE Viscosity Grade chart on page 17 in the Maintenance section shows other viscosities to use in different average temperatures.)
6. Thread the dipstick back in clockwise.
7. **NOTICE: Do not run the engine with too little oil. Engine will shut off if engine oil level is too low.**

Checking and Filling Fuel



WARNING! TO PREVENT SERIOUS INJURY FROM FIRE:

Fill the fuel tank in a well-ventilated area away from ignition sources. If the engine is hot from use, shut the engine off and wait for it to cool before adding fuel. Do not smoke.

1. Clean the Fuel Cap and the area around it.
2. Unscrew and remove the Fuel Cap.
3. Remove the Strainer and remove any dirt and debris. Then replace the Strainer.

Note: Do not use gasoline containing more than 10% ethanol (E10). Do not use E85 ethanol.

Note: Do not use gasoline that has been stored in a metal fuel container or a dirty fuel container. It can cause particles to enter the carburetor, affecting engine performance and/or causing damage.

4. If needed, fill the Fuel Tank to about 1 inch under the fill neck of the Fuel Tank with 87 octane or higher unleaded gasoline that has been treated with a fuel stabilizer additive. Follow fuel stabilizer manufacturer's recommendations for use.
5. Then replace the Fuel Cap.
6. Wipe up any spilled fuel and allow excess to evaporate before starting engine. To prevent FIRE, do not start the engine while the smell of fuel hangs in the air.

Starting the Engine

Before Starting the Engine



Before starting the engine:

- Inspect the equipment and engine.**
- Fill the engine with the proper amount and type of both stabilizer-treated unleaded gasoline and oil.**
- TURN ON WATER SUPPLY, REMOVE NOZZLE, POINT WAND IN SAFE DIRECTION, AND HOLD DOWN TRIGGER UNTIL ALL AIR IS RELEASED FROM THE SYSTEM, AT LEAST 30 SECONDS. Then release the Trigger, lock it in the safety position and replace Nozzle before starting engine.**

Manual Start

1. To start a cold engine, move the Choke to the START position.
To restart a warm engine, leave the Choke in the RUN position.

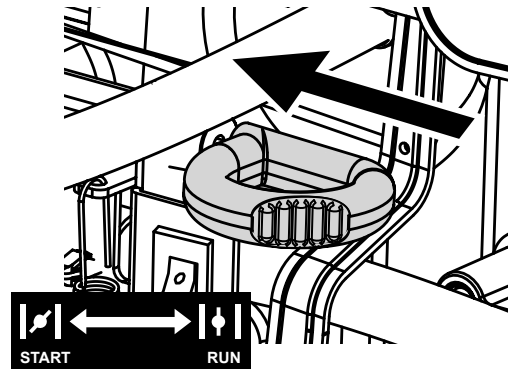
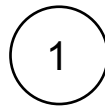

2. Push the Engine Switch to the ON position.

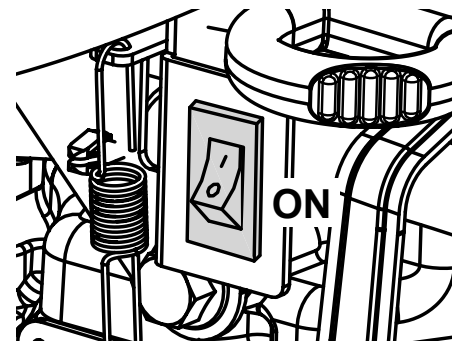
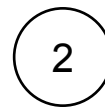

Note: If engine does not start, check engine oil level. Engine will not start with low or no engine oil.

3. Grip the Starter Handle of the Engine loosely and pull it slowly two times to allow the gasoline to flow into the Engine's carburetor. Then pull the Starter Handle gently until resistance is felt. Allow Cable to retract fully and then pull it quickly. Repeat until the engine starts.

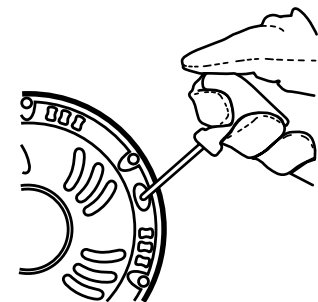
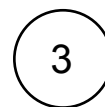

Note: Do not let the Starter Handle snap back against the engine. Hold it as it recoils so it doesn't hit the engine.

4. Allow the Engine to run for several seconds. Then, if the Choke lever is in the START position, move the Choke Lever very slowly to its RUN position.

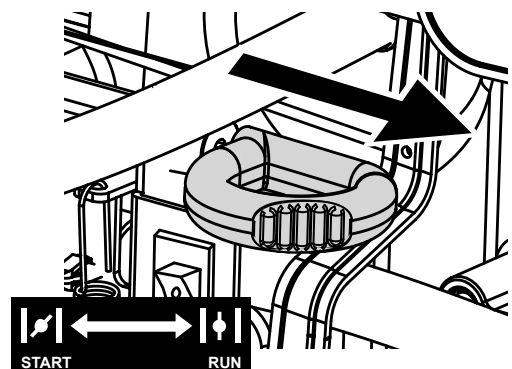

Note: Moving the Choke Lever too fast could stall the engine.

Starting the Engine (continued)

Break-in Period:

- a. Breaking-in the engine will help to ensure proper equipment and engine operation.
- b. The operational break-in period will last about 3 hours of use. During this period:
 - Do not apply a heavy load to the equipment.
- c. The maintenance break-in period will last about 20 hours of use.
 - Change the engine oil after this period.

Under normal operating conditions subsequent maintenance follows the schedule explained in the MAINTENANCE section.

Pressure Washer Operation

⚠ WARNING

Do not direct spray from the Pressure Washer at a person or an animal. The water stream could cause serious injury.

CAUTION

Use the Pressure Washer only on surfaces able to withstand the force of the spray.

1. Choose the Nozzle that best meets the needs of the job. See Chart below. Only use the Nozzles on surfaces capable of withstanding the force of the spray. Only use the Black Nozzle when using pressure washer detergent. The power of the other Nozzles will propel mist back at the operator and can embed detergent into the surface.
2. Pull back the quick connect collar and push the Nozzle onto the end of the Wand. Make sure the quick connect collar locks the Nozzle in place.
3. With water supply on and Engine running following directions in "Starting the Engine" on page 13, unlock and hold down the Trigger to start the stream. Be aware that when it is first started, the gun will kick.
4. Start with a low pressure Nozzle, and gradually use higher pressures as needed. Test spray the edge of the surface to be cleaned first to make sure that the stream is not too strong for the surface. If the stream damages the surface, move further away from the surface being cleaned to reduce the pressure being applied to the surface. If the stream is still too strong, lock the Trigger in the safety position and change to a lower pressure Nozzle.
5. Hold the Wand at about a 45° angle when cleaning; spraying the surface directly could embed dirt into the surface (especially with the high pressure Nozzles). Spray at a distance of about three to five feet.
6. Clean vertical and sloped surfaces from the top down.
7. When cleaning horizontal surfaces, occasionally use the stream to clear the area of excess water.
8. Hold the Trigger down and move the Wand back and forth slowly and steadily to pressure wash the surface. Take special care when spraying surfaces made of two different materials (brick and mortar, for example), so as to not damage the softer of the two materials during pressure washing.
9. If the surface is streaked or uneven at the end of a job, switch to a Nozzle that has a wider spray pattern to blend the affected area.

NOZZLE SELECTION CHART

NOZZLE	USE FOR
Black—Low Pressure	Use with pressure washer detergent.
White—Wide Spray	Moderate cleaning for autos and boats.
Green—Medium Spray	Standard cleaning for driveways and paint removal.
Yellow—Narrow Spray	Heavy cleaning for decks and siding.
Red—Pencil Spray	Intense cleaning for stubborn stains and dirt. Use only on hard surfaces—can damage concrete, wood, paint, etc.

⚠ CAUTION! Do not allow the Pressure Washer to run without the Trigger held down for more than two minutes. The water will heat up and damage the Pressure Washer. **RISK OF BURNS!** The Pump will expel very hot water if allowed to idle too long.

Note: During normal operation the Thermal Relief Valve may release small amounts of water intermittently.

If using detergent:

Read detergent directions. Only use detergents specified for use with pressure washers. Open the Detergent Tank Lid, fill Detergent Tank with prepared detergent solution and close the Lid. The Pressure Washer will draw one gallon of detergent for every seven gallons of water. Only use the Black (low pressure) Nozzle when spraying detergents.

Stopping the Engine and Pressure Washer

1. To stop the engine in an emergency, turn the Engine Switch OFF.

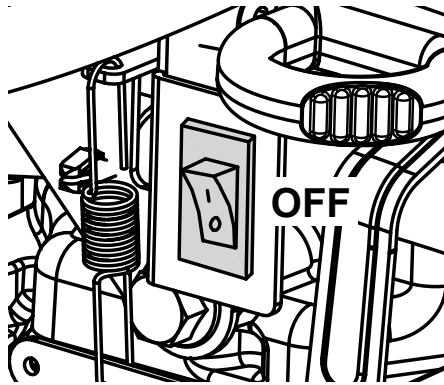

2. Under normal conditions, use the following procedure:
 - a. Release the Trigger on the Spray Gun handle.
 - b. Turn the Engine Switch OFF.
 - c. Turn the water supply off.

3. Squeeze the Trigger to release excess pressure.
4. If pressure washer detergent has been used, run clean water through the system to eliminate detergent residue using the following procedure:
 - a. Turn off the Engine as detailed in step 2.
 - b. Fill the Detergent Tank with clean water.
 - c. Remove the Nozzle and restart the Engine following directions in "Starting the Engine" on page 1313.
 - d. Point Wand in safe direction and hold down Trigger to flush water through system until clean.
 - e. Turn off the Engine as detailed in step 2.

Folding and Storing

1. Disconnect the water supply hose from the water inlet connection on the Pump.
2. Drain all water out of the Pressure Washer and lock the Trigger. Clean external parts with clean cloth.
3. Disconnect the Pressure Hose from the Pump and Spray Gun, drain water from Hose and coil.
4. Loosen the nut and remove the Wand from the Spray Gun.
5. Loosen Handle Knobs, fold Handle forward to a horizontal position and tighten the Handle Knobs.
6. Clip the Wand into the Wand Holders and hang the Spray Gun from the Spray Gun Holder as shown in Figure H.
7. Store the equipment indoors out of children's reach.



Figure H

NOTICE

See "Long-Term Storage" on page 19 for complete storage instructions.

⚠️ WARNING

TO PREVENT SERIOUS INJURY FROM ACCIDENTAL STARTING:

Turn the Power Switch of the equipment to its “OFF” position, wait for the engine to cool, and disconnect the spark plug cap before performing any inspection, maintenance, or cleaning procedures.

TO PREVENT SERIOUS INJURY FROM EQUIPMENT FAILURE:

Do not use damaged equipment. If abnormal noise, vibration, or excess smoking occurs, have the problem corrected before further use.

Follow all service instructions in this manual. The engine may fail critically if not serviced properly.



Many maintenance procedures, including any not detailed in this manual, will need to be performed by a qualified technician for safety. If you have any doubts about your ability to safely service the equipment or engine, have a qualified technician service the equipment instead.

Cleaning, Maintenance, and Lubrication Schedule

Note: This maintenance schedule is intended solely as a general guide. If performance decreases or if equipment operates unusually, check systems immediately. The maintenance needs of each piece of equipment will differ depending on factors such as duty cycle, temperature, air quality, fuel quality, and other factors.

Note: The following procedures are in addition to the regular checks and maintenance explained as part of the regular operation of the engine and equipment.

Procedure	Before Each Use	Monthly or every 20 hr. of use	Every 3 mo. or 50 hr. of use	Every 6 mo. or 100 hr. of use	Yearly or every 300 hr. of use	Every 2 Years
Brush off outside of engine	✓	✓	✓	✓	✓	✓
Check engine oil level	✓	✓	✓	✓	✓	✓
Check air cleaner			✓	✓	✓	✓
Change engine oil		✓		✓	✓	✓
Clean air filter			✓*	✓	✓	✓
Check and clean spark plug				✓	✓	✓
1. Check/adjust idle speed 2. Check/adjust valve clearance 3. Clean fuel tank, strainer and carburetor 4. Clean carbon build-up from combustion chamber					✓**	✓**
Replace fuel line if necessary						✓**

*Service more frequently when used in dusty areas. **These items should be serviced by a qualified technician.

Checking and Filling Fuel



⚠️ WARNING! TO PREVENT SERIOUS INJURY FROM FIRE:

Fill the fuel tank in a well-ventilated area away from ignition sources. If the engine is hot from use, shut the engine off and wait for it to cool before adding fuel. Do not smoke.

1. Clean the Fuel Cap and the area around it.
2. Unscrew and remove the Fuel Cap.
3. Remove the Strainer and remove any dirt and debris. Then replace the Strainer.

Note: Do not use gasoline containing more than 10% ethanol (E10). Do not use E85 ethanol.

Note: Do not use gasoline that has been stored in a metal fuel container or a dirty fuel container. It can cause particles to enter the carburetor, affecting engine performance and/or causing damage.

4. If needed, fill the Fuel Tank to about 1 inch under the fill neck of the Fuel Tank with 87 octane or higher unleaded gasoline that has been treated with a fuel stabilizer additive. Follow fuel stabilizer manufacturer's recommendations for use.
5. Then replace the Fuel Cap.
6. Wipe up any spilled fuel and allow excess to evaporate before starting engine. To prevent FIRE, do not start the engine while the smell of fuel hangs in the air.

Pump Maintenance

The Pressure Washer Pump is maintenance free. If any sign of oil leakage is present on or around the Pump, DO NOT operate the Pressure Washer. Have the unit serviced by a qualified technician.

Engine Oil Change

⚠️ CAUTION! Oil is very hot during operation and can cause burns. Wait for engine to cool before changing oil.

1. Make sure the engine is stopped and is level.
2. Close the Fuel Valve.
3. Place a drain pan (not included) underneath the crankcase's drain plug.
4. Remove the drain plug and, if possible, tilt the crankcase slightly to help drain the oil out. Recycle used oil.
5. Replace the drain plug and tighten it.
6. Clean the top of the Dipstick and the area around it. Remove the Dipstick by turning it counterclockwise, and wipe it off with a clean, lint free rag.

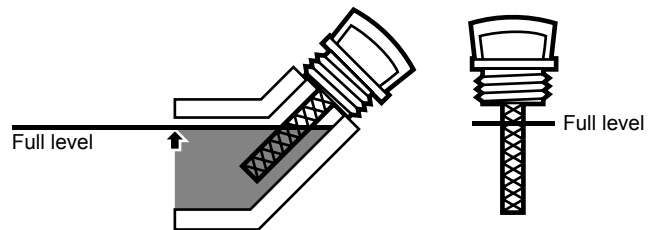

7. Add the appropriate type of oil until the oil level is at the full level. SAE 10W-30 oil is recommended for general use. The SAE Viscosity Grade chart shows other viscosities to use in different average temperatures.

SAE Viscosity Grades

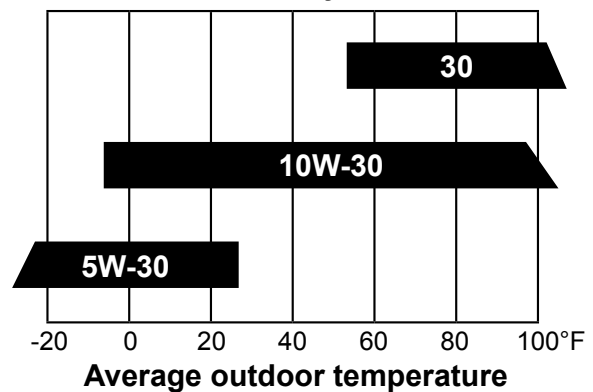

8. Thread the dipstick back in clockwise.

NOTICE: Do not run the engine with too little oil. Engine will not start with low or no engine oil

Spark Plug Maintenance

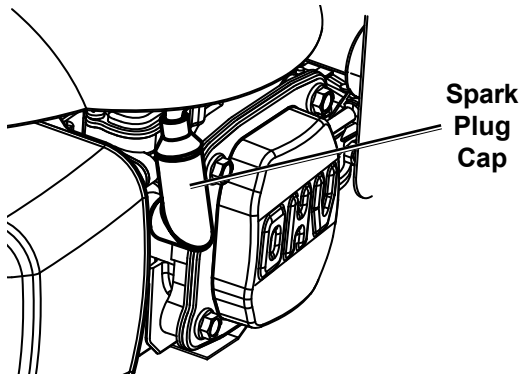

1. Disconnect spark plug cap from end of plug. Clean out debris from around spark plug.
2. Using a spark plug wrench, remove the spark plug.
3. Inspect the spark plug: If the electrode is oily, clean it using a clean, dry rag. If the electrode has deposits on it, polish it using emery paper. If the white insulator is cracked or chipped, the spark plug needs to be replaced.

Recommended Spark Plugs

NHSP® / TORCH®	F5RTC
----------------	-------

NOTICE: Using an incorrect spark plug may damage the engine.

4. When installing a new spark plug, adjust the plug's gap to the specification on the Specifications chart. Do not pry against the electrode, the spark plug can be damaged.
5. Install the new spark plug or the cleaned spark plug into the engine.
 - **Gasket-style:**
Finger-tighten until the gasket contacts the cylinder head, then tighten about 1/2-2/3 turn more.
 - **Non-gasket-style:**
Finger-tighten until the plug contacts the cylinder head, then tighten about 1/16 turn more.

NOTICE: Tighten the spark plug properly.

If loose, the spark plug will cause the engine to overheat.

If overtightened, the threads in the engine block will be damaged.

6. Apply dielectric spark plug boot protector (not included) to the end of the spark plug and reattach the wire securely.

Air Filter Maintenance

1. Remove the Air Cleaner Cover and the air filter(s) and check for dirt. Clean as described below.
2. **Cleaning:**
 - For paper filters:
To prevent injury from dust and debris, wear ANSI-approved safety goggles, NIOSH-approved dust mask/respirator, and heavy-duty work gloves. In a well-ventilated area away from bystanders, use pressurized air to blow dust out of the filter. If this does not get the filter clean, replace it.
 - For foam filters:
Wash the filter in warm water and mild detergent several times. Rinse. Squeeze out excess water and allow it to dry completely. Soak the filter in lightweight oil briefly, then squeeze out the excess oil.
3. Install the cleaned filter(s). Secure the Air Cleaner Cover before use.

Long-Term Storage

When the equipment is to remain idle for longer than 20 days, prepare the Engine for storage as follows:

1. CLEANING:

Wait for Engine to cool, then clean Engine with dry cloth. **NOTICE: Do not clean using water.** The water will gradually enter the Engine and cause rust damage. Apply a thin coat of rust preventive oil to all metal parts.

2. FUEL:

To protect the fuel tank during storage, fill the tank with gasoline that has been treated with a fuel stabilizer additive. Follow fuel stabilizer manufacturer's recommendations for use. Refer to *Checking and Filling Fuel* on page 12.



⚠ WARNING! TO PREVENT SERIOUS INJURY FROM FIRE:

Fill tank in a well-ventilated area away from ignition sources. If the engine is hot from use, shut the engine off and wait for it to cool before adding fuel. Do not smoke.

3. LUBRICATION:

- Change engine oil.
- Clean out area around spark plug. Remove spark plug and pour one tablespoon of engine oil into cylinder through spark plug hole.
- Replace spark plug, but leave spark plug cap disconnected.
- Pull Starter Handle to distribute oil in cylinder. Stop after one or two revolutions when you feel the piston start the compression stroke (when you start to feel resistance).

4. PUMP PREPARATION:

- Disconnect the Pressure Hose and water supply hose from the Pump.
- Connect a short length of garden hose with a male hose connector on one end to the Pump's water inlet connection.
- Use a funnel to add approximately six ounces of RV antifreeze to the Pump.
NOTICE: Use only RV antifreeze. Other types of antifreeze are corrosive and can damage Pump.
- With spark plug cap disconnected and Engine switch in OFF position, pull Starter Handle several times until antifreeze begins to come out of Pump outlet fitting.
- Remove garden hose from Pump.

5. STORAGE AREA:

Cover and store in a dry, level, well-ventilated area out of reach of children. Storage area should also be away from ignition sources, such as water heaters, clothes dryers, and furnaces.

6. EVERY 3 MONTHS, TO PROTECT ENGINE AND WARRANTY COVERAGE:

- Safely drain antifreeze, and dispose of properly.
- Connect Pressure Hose and water supply hose.
- Turn on water supply, remove nozzle, point wand in safe direction, and hold down trigger until all air is released from the system, at least 30 seconds. Then release the Trigger, lock it in the safety position and replace Nozzle before starting engine.
- Discharge nozzle in safe direction run engine for 15-20 minutes or the Warranty is VOID. Turn off engine.
- Discharge nozzle in safe direction, and then disconnect hoses and drain water.
- Connect a short length of garden hose with a male hose connector on one end to the Pump's water inlet connection.
- Use a funnel to add approximately six ounces of RV antifreeze to the Pump.
NOTICE: Use only RV antifreeze. Other types of antifreeze are corrosive and can damage Pump.

7. AFTER STORAGE:

- Before starting the Engine during or after storage, keep in mind that untreated gasoline will deteriorate quickly. Drain the fuel tank and change to fresh fuel if untreated gasoline has been sitting for a month, if treated gasoline has been sitting beyond the fuel stabilizer's recommended time period, or if the Engine does not start.
- With spark plug cap disconnected and Engine switch in OFF position, pull Starter Handle several times to discharge antifreeze out of the Pump outlet fitting before using Pressure Washer.

Troubleshooting

SAFETY

SETUP

OPERATION

MAINTENANCE

Problem	Possible Causes	Probable Solutions
Engine will not start	FUEL RELATED: <ol style="list-style-type: none"> No fuel in tank or fuel valve closed. Choke not in START position, cold engine. Gasoline with more than 10% ethanol used. (E15, E20, E85, etc.) Low quality or deteriorated, old gasoline. Carburetor not primed. Dirty fuel passageways. Carburetor needle stuck. Fuel can be smelled in the air. Too much fuel in chamber. This can be caused by the carburetor needle sticking. Clogged Fuel Filter. 	FUEL RELATED: <ol style="list-style-type: none"> Fill fuel tank with fresh 87+ octane stabilizer-treated unleaded gasoline and open fuel valve. Do not use gasoline with more than 10% ethanol (E15, E20, E85, etc.). Move Choke to START position. Clean out ethanol rich gasoline from fuel system. Replace components damaged by ethanol. Use fresh 87+ octane stabilizer-treated unleaded gasoline only. Do not use gasoline with more than 10% ethanol (E15, E20, E85, etc.). Use fresh 87+ octane stabilizer-treated unleaded gasoline. Do not use gasoline with more than 10% ethanol (E15, E20, E85, etc.). Pull on Starter Handle to prime. Clean out passageways using fuel additive. Heavy deposits may require further cleaning. Gently tap side of carburetor float chamber with screwdriver handle. Turn Choke to RUN position. Remove spark plug and pull the start handle several times to air out the chamber. Reinstall spark plug and set Choke to START position. Replace Fuel Filter.
	IGNITION (SPARK) RELATED: <ol style="list-style-type: none"> Spark plug cap not connected securely. Spark plug electrode wet or dirty. Incorrect spark plug gap. Spark plug cap broken. Incorrect spark timing or faulty ignition system. 	IGNITION (SPARK) RELATED: <ol style="list-style-type: none"> Connect spark plug cap properly. Clean spark plug. Correct spark plug gap. Replace spark plug cap. Have qualified technician diagnose/repair ignition system.
	COMPRESSION RELATED: <ol style="list-style-type: none"> Cylinder not lubricated. Problem after long storage periods. Loose or broken spark plug. (Hissing noise will occur when trying to start.) Loose cylinder head or damaged head gasket. (Hissing noise will occur when trying to start.) Engine valves or tappets mis-adjusted or stuck. 	COMPRESSION RELATED: <ol style="list-style-type: none"> Pour tablespoon of oil into spark plug hole. Crank engine a few times and try to start again. Tighten spark plug. If that does not work, replace spark plug. If problem persists, may have head gasket problem, see #3. Tighten head. If that does not remedy problem, replace head gasket. Have qualified technician adjust/repair valves and tappets.
	ENGINE OIL RELATED: <ol style="list-style-type: none"> Low engine oil. Engine mounted on slope, triggering low oil shutdown. 	ENGINE OIL RELATED: <ol style="list-style-type: none"> Fill engine oil to proper level. Check engine oil before EVERY use. Operate engine on level surface. Check engine oil level.



Follow all safety precautions whenever diagnosing or servicing the equipment or engine.

Problem	Possible Causes	Probable Solutions
Engine misfires	<ol style="list-style-type: none"> Spark plug cap loose. Incorrect spark plug gap or damaged spark plug. Defective spark plug cap. Old or low quality gasoline. Incorrect compression. 	<ol style="list-style-type: none"> Check cap and wire connections. Re-gap or replace spark plug. Replace spark plug cap. Use only fresh 87+ octane stabilizer-treated unleaded gasoline. Do not use gasoline with more than 10% ethanol (E15, E20, E85, etc.). Diagnose and repair compression. (Use Engine will not start: COMPRESSION RELATED section.)
Engine stops suddenly	<ol style="list-style-type: none"> Fuel tank empty or full of impure or low quality gasoline. Low oil shutdown. Defective fuel tank cap creating vacuum, preventing proper fuel flow. Faulty magneto. Disconnected or improperly connected spark plug cap. 	<ol style="list-style-type: none"> Fill fuel tank with fresh 87+ octane stabilizer-treated unleaded gasoline. Do not use gasoline with more than 10% ethanol (E15, E20, E85, etc.). Fill engine oil to proper level. Check engine oil before EVERY use. Test/replace fuel tank cap. Have qualified technician service magneto. Secure spark plug cap.
Engine stops when under heavy load	<ol style="list-style-type: none"> Dirty air filter Engine running cold. 	<ol style="list-style-type: none"> Clean element. Allow engine to warm up prior to operating equipment.
Engine knocks	<ol style="list-style-type: none"> Old or low quality gasoline. Engine overloaded. Incorrect spark timing, deposit buildup, worn engine, or other mechanical problems. 	<ol style="list-style-type: none"> Fill fuel tank with fresh 87+ octane stabilizer-treated unleaded gasoline. Do not use gasoline with more than 10% ethanol (E15, E20, E85, etc.). Do not exceed equipment's load rating. Have qualified technician diagnose and service engine.
Engine backfires After sudden impact, engine will run, but equipment will not operate	<ol style="list-style-type: none"> Impure or low quality gasoline. Engine too cold. Intake valve stuck or overheated engine. Incorrect timing. <p>Shaft key or other shear pin broken by impact to disconnect engine and limit damage.</p>	<ol style="list-style-type: none"> Fill fuel tank with fresh 87+ octane stabilizer-treated unleaded gasoline. Do not use gasoline with more than 10% ethanol (E15, E20, E85, etc.). Use cold weather fuel and oil additives to prevent backfiring. Have qualified technician diagnose and service engine. Check engine timing. <p>Have qualified technician check and replace broken shaft key or other shear pins.</p>



Follow all safety precautions whenever diagnosing or servicing the equipment or engine.

Problem	Possible Causes	Probable Solutions
Does not produce high pressure	<ol style="list-style-type: none"> 1. Diameter of water supply hose too small 2. Water supply is restricted. 3. Not enough water supply. 	<ol style="list-style-type: none"> 1. Replace hose with a 3/4-inch hose. 2. Check water supply hose for kinks, leaks, or blockage. 3. Open water faucet all the way.
Output pressure varies	<ol style="list-style-type: none"> 1. Not enough water supply. 2. Water inlet screen is clogged. 3. Nozzle is clogged. 4. Nozzle has mineral build up. 	<ol style="list-style-type: none"> 1. Check water supply hose for kinks, leaks, or blockage. Open faucet all the way. 2. Remove inlet screen and rinse out. 3. Remove Nozzle and clean. 4. Remove Nozzle and clean with vinegar.
No intake of chemicals.	<ol style="list-style-type: none"> 1. Chemical hose not properly inserted into unit. 2. Tube cracked or split. 3. Wrong Nozzle. 4. Injector turned off. 5. Injection tube strainer clogged. 6. Nozzle blocked. 7. Dried chemicals in injector. 	<ol style="list-style-type: none"> 1. Push firmly into injector. 2. Replace tube. 3. Switch to Black Nozzle. 4. Turn collar counterclockwise. 5. Clean strainer. 6. Clean Nozzle. 7. Dissolve by running warm water through the injection tube. Run clean water through injector until clear.



Follow all safety precautions whenever diagnosing or servicing the equipment or engine.

PREDATOR[®]
OUTDOOR POWER EQUIPMENT

PLEASE READ THE FOLLOWING CAREFULLY

THE MANUFACTURER AND/OR DISTRIBUTOR HAS PROVIDED THE PARTS LIST AND ASSEMBLY DIAGRAM IN THIS MANUAL AS A REFERENCE TOOL ONLY. NEITHER THE MANUFACTURER OR DISTRIBUTOR MAKES ANY REPRESENTATION OR WARRANTY OF ANY KIND TO THE BUYER THAT HE OR SHE IS QUALIFIED TO MAKE ANY REPAIRS TO THE PRODUCT, OR THAT HE OR SHE IS QUALIFIED TO REPLACE ANY PARTS OF THE PRODUCT. IN FACT, THE MANUFACTURER AND/OR DISTRIBUTOR EXPRESSLY STATES THAT ALL REPAIRS AND PARTS REPLACEMENTS SHOULD BE UNDERTAKEN BY CERTIFIED AND LICENSED TECHNICIANS, AND NOT BY THE BUYER. THE BUYER ASSUMES ALL RISK AND LIABILITY ARISING OUT OF HIS OR HER REPAIRS TO THE ORIGINAL PRODUCT OR REPLACEMENT PARTS THERETO, OR ARISING OUT OF HIS OR HER INSTALLATION OF REPLACEMENT PARTS THERETO

Record Product's Serial Number Here: _____

Note: If product has no serial number, record month and year of purchase instead.

Note: Some parts are listed and shown for illustration purposes only, and are not available individually as replacement parts.

PREDATOR[®]
OUTDOOR POWER EQUIPMENT

General Parts List

SAFETY

SETUP

OPERATION

MAINTENANCE

Part	Description	Qty.
1	Wand	1
2	Spray Gun	1
3	Spray Gun Holder	1
4	Knob	2
5	Handle	1
6	Handle Grip	1
7	Hose Hanger	1
8-1	Red Nozzle-0°	1
8-2	Yellow Nozzle-15°	1
8-3	Green Nozzle-25°	1
8-4	White Nozzle-40°	1
8-5	Black Nozzle-Detergent	1
9	Nozzle Grommet	5
10	Bolt	4
11	Nozzle Panel	1
12	Handle Knob	2
13	Frame	1
14	Wand Holder	2

Part	Description	Qty.
15	Pressure Hose	1
16	Bolt	2
17	Pin	2
18	Washer	4
19	Axle	2
20	Wheel	2
21	Gasket	1
22	Rubber Pad	1
23	Bolt	1
24	Detergent Tank	1
25	Detergent Tank Lid	1
26	Detergent Tube	1
27	Key	1
28	Pump	1
29	Engine Mounting Bolt	3
30	Engine	1
31	Flange Nut	3
32	Bolt	1

General Assembly Diagram

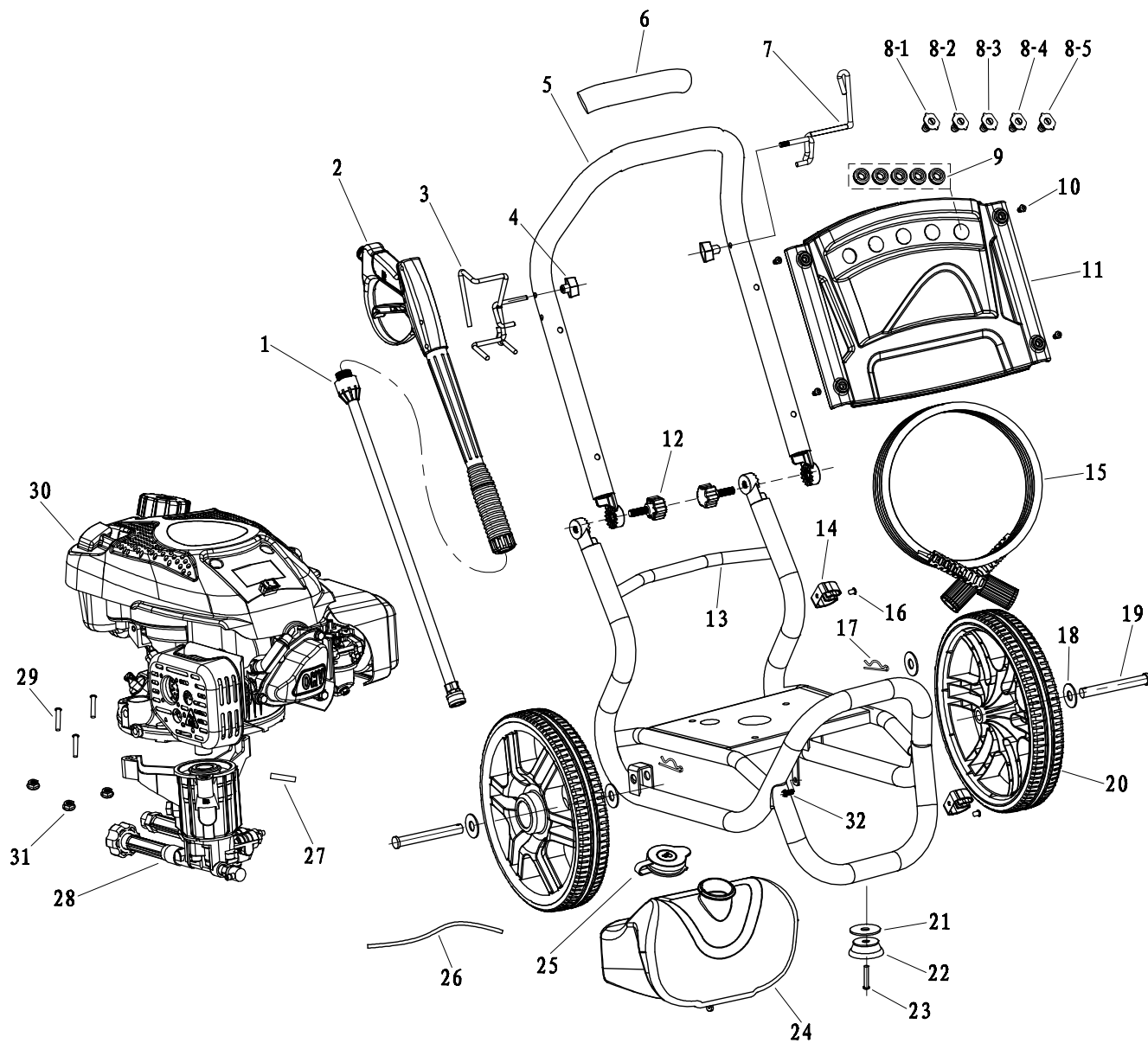

SAFETY

SETUP

OPERATION

MAINTENANCE

Pump Parts List

SAFETY

SETUP

OPERATION

MAINTENANCE

Part	Description	Qty.
1A	Nut M6	1
2A	Grub Screw M6x16	1
3A	Handle Insert	1
4A	Plate Spring	2
5A	Spring	1
6A	Piston	1
7A	O-Ring Ø6.02x2.62	1
8A	O-Ring Ø6.07x1.78	1
9A	Ring	1
10A	Piston Guide	1
11A	O-Ring Ø14x1.78	5
12A	O-Ring Ø10.82x1.78	1
13A	By-Pass Jet	1
14A	Seat	1
15A	O-Ring Ø9x1	1
17A	Hose Nipple	1
18A	O-Ring Ø4.48x1.78	1
19A	Ball	1
20A	Spring	1
21A	Screw	1
25A	Plug	3
26A	Check Valve	6
27A	Pump Head	1
28A	Gasket	3
29A	Bushing	3
30A	Seal	3

Part	Description	Qty.
31A	Plug	1
32A	Housing	1
33A	Head Bolt M8x45	3
34A	Inlet Fitting 3/4" NH	1
35A	Inlet Extension	1
36A	Filter	1
37A	O-Ring Ø4x2.5	1
38A	Jet	1
39A	Spring	1
40A	O-Ring Ø8.73x1.78	2
41A	Detergent Injector	1
42A	Outlet Extension	1
43A	Spring	3
44A	Piston	3
45A	Ring	3
46A	Thrust Washer	1
47A	Bearing	1
48A	Thrust Washer	1
49A	Hollow Shaft	1
50A	Bearing	1
51A	Circlip Øi72	1
52A	Seal	1
53A	O-Ring Ø23.52x1.78	3
54A	Bushing	3
55A	O-Ring Ø14x2	2
56A	O-Ring Ø4.48x1.78	1

When ordering replacement parts from this list, the "A" suffix must be included in order to get the correct part.

Pump Assembly Diagram

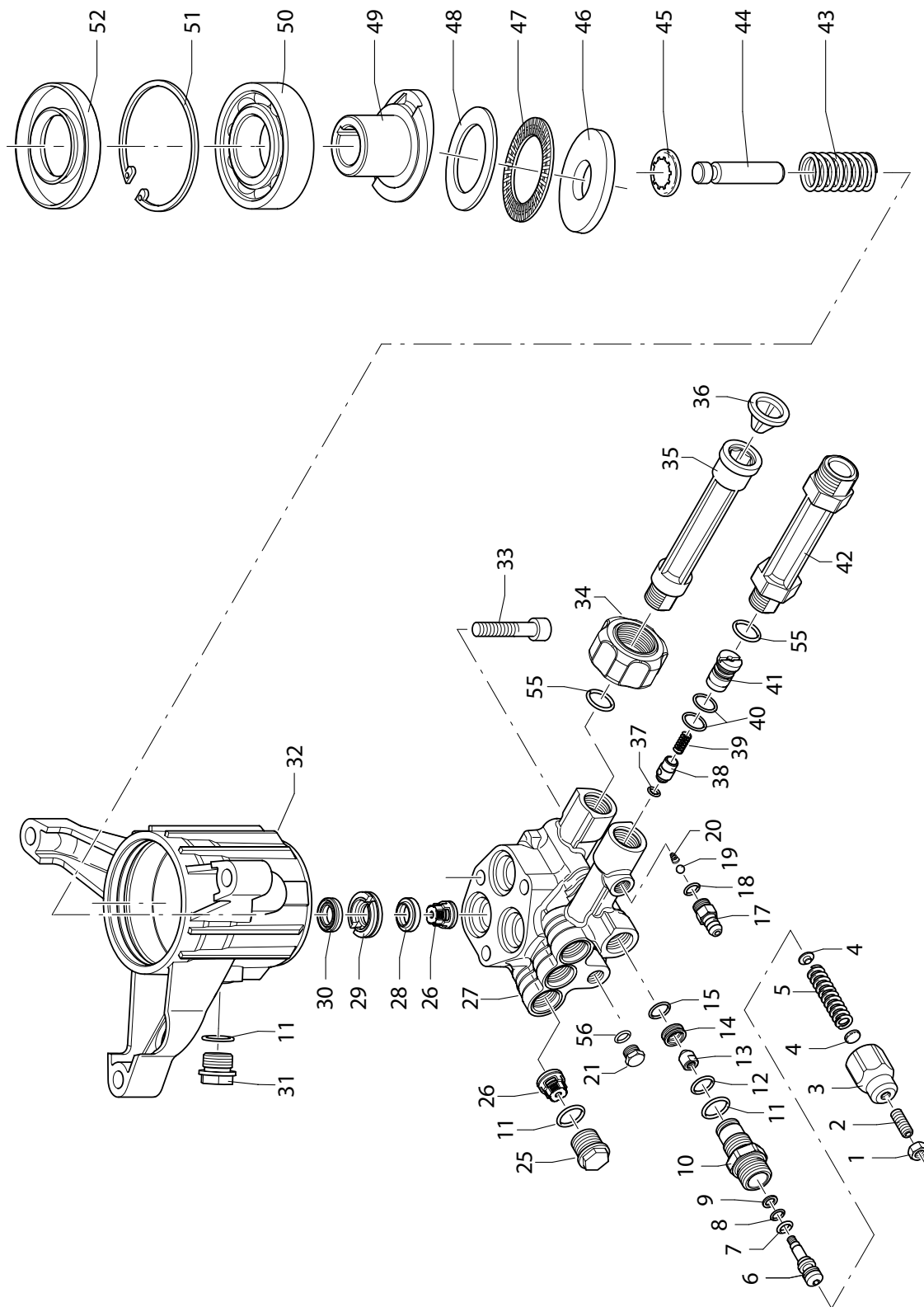

SAFETY

SETUP

OPERATION

MAINTENANCE

Engine Parts List

SAFETY

SETUP

OPERATION

MAINTENANCE

Part	Description	Qty.
1B	Bolt M6x14	10
2B	Cylinder Head Cover	1
3B	Valve Cover Gasket	1
4B	Rocker Arm Assembly	2
5B	Lock Nut	2
6B	Nut	2
7B	Rocker Arm	2
8B	Rocker Arm Stud	2
9B	Valve Spring Seat	2
10B	Spring Valve	2
11B	Intake Valve Seal	1
12B	Exhaust Valve	1
13B	Intake Valve	1
14B	Bolt M8x54	4
15B	Rocker Arm Base	1
16B	Cylinder Head	1
17B	Spark Plug	1
18B	Stud M6x95	2
19B	Muffler Gasket	1
20B	Muffler	1
21B	Muffler Guard	1
22B	Flange Nut M6	4
23B	Stud M6x87	2
24B	Carburetor Insulator Gasket	1
25B	Carburetor Insulator	1
26B	Carburetor Gasket	1
27B	Carburetor	1
28B	Air Filter Gasket	1
29B	Bolt M6x20	2
30B	Air Filter Element	1
31B	Air Filter	1
32B	Cylinder Head Gasket	1
33B	Dowel Pin Φ 10x16	2
34B	Push Rod	2
35B	Tappet	2
36B	Camshaft	1
37B	Piston Ring Set	1
38B	Piston Pin Circlip	2
39B	Piston	1
40B	Piston Pin	1
41B	Connecting Rod	1
42B	Crankcase	1
43B	Crankcase Cover Gasket	1
44B	Bearing 6205	1
45B	Crankshaft	1
46B	Dipstick	1
47B	Bolt M6x35	1
48B	Oil Return Seal	1
49B	Washer Φ 25.4x Φ 34x1	1
50B	Drain Bolt Washer M10x1.25x15	1
51B	Washer Φ 10x1.5x Φ 16	1

Part	Description	Qty.
52B	Dowel Pin Φ 9x14	1
53B	Crankcase Cover	1
54B	Bolt M6x28	7
55B	Oil Seal Φ 25x Φ 38x7	1
56B	Dowel Pin Φ 7x14	1
57B	Governor Gear	1
58B	Governor Gear Mounting Plate	1
59B	Ground Wire	1
60B	Governor Spring	1
61B	Engine Switch	1
62B	Governor Gear Bracket Assembly	1
63B	Governor Lever	1
64B	Choke Lever	1
65B	Shield Block	1
66B	Bolt M6x12	2
67B	Vent Hose	1
68B	Cotter Pin	1
69B	Oil Seal Φ 6x Φ 11x4	1
70B	Governor Gear Shaft	1
71B	Wire Clamp	1
72B	Idle Spring	1
73B	Throttle Linkage	1
74B	Fuel Hose Φ 6.3x Φ 12.5x300	1
75B	Fuel Hose Clamp	2
76B	Fuel Filter	1
77B	Fuel Tank Gasket	2
78B	Fuel Tank	1
79B	Vibration Pad	1
80B	Fuel Tank Damping Pad	1
81B	Tank Nut	1
82B	Fuel Cap Inner Cover	1
83B	Fuel Cap	1
84B	Ignition Module	1
85B	Shield Block	1
86B	Bolt M6x25	2
87B	Second Air Valve	1
88B	Breather Valve Spring	1
89B	Breather Screen	1
90B	Oil Seal Φ 22x Φ 35x6	1
91B	Oil Filter Gasket	1
92B	Breather Cover	1
93B	Flywheel	1
94B	Cooling Fan	1
95B	Starter Cup	1
96B	Nut M14x1.5	1
97B	Stud M6x74	1
98B	Stud M6x78.5	2
99B	Blower Housing	1
100B	Nut	3
101B	Recoil Starter	1

When ordering replacement parts from this list, the "B" suffix must be included in order to get the correct part.

Engine Assembly Diagram

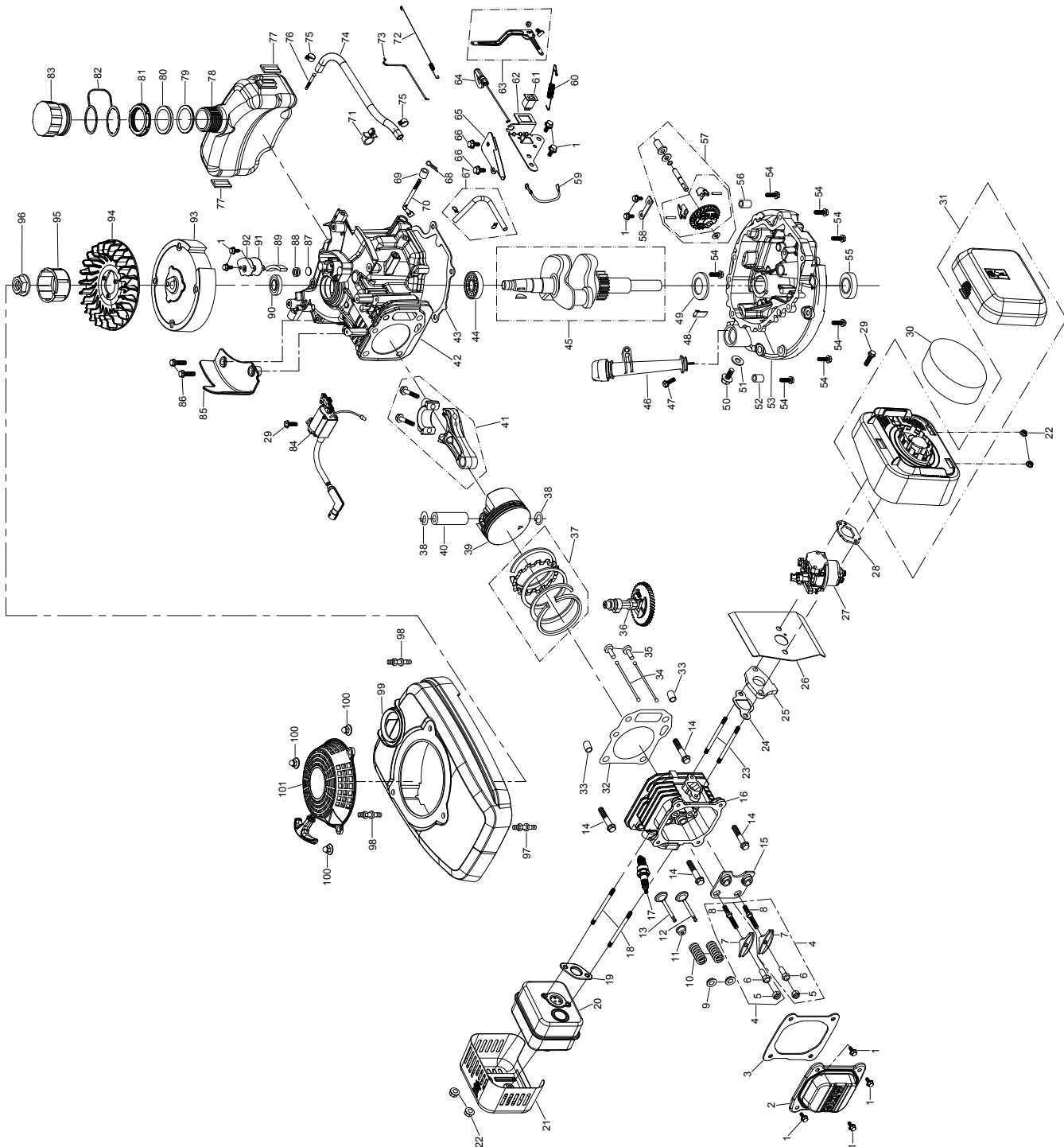

SAFETY

SETUP

OPERATION

MAINTENANCE

Limited 90 Day Warranty (Retail)

Harbor Freight Tools Co. makes every effort to assure that its products meet high quality and durability standards, and warrants to the original purchaser that this product is free from defects in materials and workmanship for the period of 90 days from the date of purchase. This warranty does not apply to damage due directly or indirectly, to misuse, abuse, negligence or accidents, repairs or alterations outside our facilities, criminal activity, improper installation, normal wear and tear, or to lack of maintenance. We shall in no event be liable for death, injuries to persons or property, or for incidental, contingent, special or consequential damages arising from the use of our product. Some states do not allow the exclusion or limitation of incidental or consequential damages, so the above limitation of exclusion may not apply to you. THIS WARRANTY IS EXPRESSLY IN LIEU OF ALL OTHER WARRANTIES, EXPRESS OR IMPLIED, INCLUDING THE WARRANTIES OF MERCHANTABILITY AND FITNESS, EXCEPT FOR THE EMISSIONS CONTROL SYSTEM WARRANTY BELOW.

To take advantage of this warranty, the product or part must be returned to us with transportation charges prepaid. Proof of purchase date and an explanation of the complaint must accompany the merchandise. If our inspection verifies the defect, we will either repair or replace the product at our election or we may elect to refund the purchase price if we cannot readily and quickly provide you with a replacement. We will return repaired products at our expense, but if we determine there is no defect, or that the defect resulted from causes not within the scope of our warranty, then you must bear the cost of returning the product.

This warranty gives you specific legal rights and you may also have other rights which vary from state to state.

Emissions Control System Warranty

The California Air Resources Board and Harbor Freight Tools (HFT) are pleased to explain the emissions control system warranty on your 2017 Small Off-Road Engine, in addition to the Retail Warranty above. In California, new equipment that uses small off-road engines must be designed, built, and equipped to meet the State's stringent anti-smog standards. HFT must warrant that the emissions control system on your engine will be free from defects in material and workmanship for two (2) years, provided there has been no abuse, neglect, or improper maintenance of your engine.

Your emissions control system may include parts such as the carburetor or fuel-injection system, the ignition system, catalytic converter, fuel tanks, fuel lines, fuel caps, valves, canisters, vapor hoses, clamps, connectors, and other emissions-related assemblies.

Where a warrantable condition exists, HFT will repair or replace, at our option, your engine if at no cost to you, including diagnosis, parts and labor.

MANUFACTURER'S WARRANTY COVERAGE

This emissions control system is warranted for two years. If any emission-related part on your engine is defective, the part will be repaired or replaced by HFT.

OWNER'S WARRANTY RESPONSIBILITIES

As the engine owner, you are responsible for the performance of the required maintenance listed in your Owner's Manual.

As the engine owner, you should however be aware that HFT may deny you warranty coverage if your engine or a part has failed due to abuse (including failure to follow the fuel use instructions contained in this manual), neglect, improper maintenance, or unapproved modifications.

You are responsible for contacting HFT as soon as the problem exists in order to obtain warranty repair or replacement, by doing either of the following: (a) contact HFT product support at 1-888-866-5797 or productsupport@harborfreight.com; or (b) bring the to your nearest Harbor Freight Tools retail store. The nearest Harbor Freight Tools retail store can be found on the internet at <http://www.harborfreight.com>. The warranty repairs or replacement should be completed in a reasonable amount of time, not to exceed 30 days. If you have a question regarding your warranty coverage, you should contact HFT product support at 1-888-866-5797 or productsupport@harborfreight.com.

GENERAL EMISSIONS WARRANTY COVERAGE

- a) The warranty period begins on the date the engine or equipment is delivered to an ultimate purchaser. The warranty period is two years.
- b) HFT warrants to the initial owner and each subsequent owner that the engine is:
1. Designed, built, and equipped so as to conform with all applicable regulations adopted by the Air Resources Board; and
 2. Free from defects in materials and workmanship that causes the failure of a warranted part for a period of two years.
- c) The warranty on emissions-related parts is as follows:
1. Any warranted part that is not scheduled for replacement as required maintenance in the written instructions provided, is warranted for the warranty period stated above. If any such part fails during the period of warranty coverage, it will be repaired or replaced HFT. Any such part repaired or replaced under the warranty will be warranted for the remaining warranty period.
 2. Any warranted part that is scheduled only for regular inspection in the written instructions is warranted for the warranty period stated above. A statement in the written instructions to the effect of "repair or replace as necessary" does not reduce the period of warranty coverage. Any such part repaired or replaced under warranty will be warranted for the remaining warranty period.
 3. Any warranted part that is scheduled for replacement as required maintenance in the written instructions will be warranted for the period of time prior to the first scheduled replacement point for that part. If the part fails prior to the first scheduled replacement, the part will be repaired or replaced by HFT. Any such part repaired or replaced under warranty will be warranted for the remainder of the period prior to the first scheduled replacement point for the part.
 4. Repair or replacement of any warranted part under the warranty will be performed at no charge to the owner at a retail store or by HFT paying for shipping the product for repair.
 5. Notwithstanding the provisions herein, warranty services or repairs will be provided at all retail stores or by contacting HFT product support at 1-888-866-5797 or productsupport@harborfreight.com.
 6. The owner will not be charged for diagnostic labor that leads to the determination that a warranted part is in fact defective, provided that such diagnostic work is performed at a retail store.
 7. HFT is liable for damages to other engine components proximately caused by a failure under warranty of any warranted part.
 8. Throughout the emissions warranty period stated above, HFT will maintain a supply of warranted parts sufficient to meet the expected demand for such parts.
 9. Any replacement part may be used in the performance of any warranty maintenance or repairs and will be provided without charge to the owner. Such use will not reduce the warranty obligations of HFT.
 10. Add-on or modified parts that are not approved by HFT may not be used. The use of any non-exempted add-on or modified parts will be grounds for disallowing a warranty claim. HFT is not liable to warrant failures of warranted parts caused by the use of a non-exempted add-on or modified part.
- d) Emission Warranty Parts List.
- | | |
|--|---|
| 1. Fuel Metering System | 4. Catalyst System (if so equipped) |
| a. Carburetor and its internal parts (and/or pressure regulator or fuel injection system). | a. Exhaust pipe stud/exhaust manifold. |
| b. Fuel tank. | b. Thermal reactor. |
| c. Cold start enrichment system. | c. Catalytic converter (if so equipped). |
| d. Air/fuel ratio feedback and control system. | 5. Particulate Controls |
| 2. Air Induction System | a. Traps, filters, precipitators, and any other device used to capture particulate emissions. |
| a. Controlled hot air intake system. | 6. Miscellaneous Items Used in Above Systems |
| b. Intake manifold. | a. Vacuum, temperature and time sensitive valves and switches. |
| c. Air filter. | b. Hoses, belts, connectors, and assemblies. |
| 3. Ignition System | 7. Evaporative Emission Control System |
| a. Spark plugs. | a. Fuel tank. |
| b. Magneto ignition system. | b. Fuel caps, valves, canisters, filters, vapor hoses, clamps, connectors, belts, and assemblies. |
| c. Spark advance/retard system. | |

HFT provides with each product written instructions for the maintenance and use of the product by the owner.

PREDATOR[®]
OUTDOOR POWER EQUIPMENT

3491 Mission Oaks Blvd. • PO Box 6009 • Camarillo, CA 93011 • 1-888-866-5797