

Owner's Manual & Safety Instructions

Save This Manual Keep this manual for the safety warnings and precautions, assembly, operating, inspection, maintenance and cleaning procedures. Write the product's serial number in the back of the manual near the assembly diagram (or month and year of purchase if product has no number). Keep this manual and the receipt in a safe and dry place for future reference.

REV 16a

CENTRALPNEUMATIC®

9GAL wheelbarrow air compressor

⚠ DANGER

Using an engine indoors CAN KILL YOU IN MINUTES.

Engine exhaust contains carbon monoxide. This is a poison you cannot see or smell.

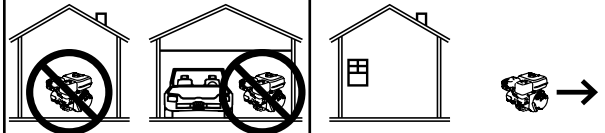

NEVER use inside a home or garage, EVEN IF doors and windows are open.

Only use OUTSIDE and far away from windows, doors, and vents.

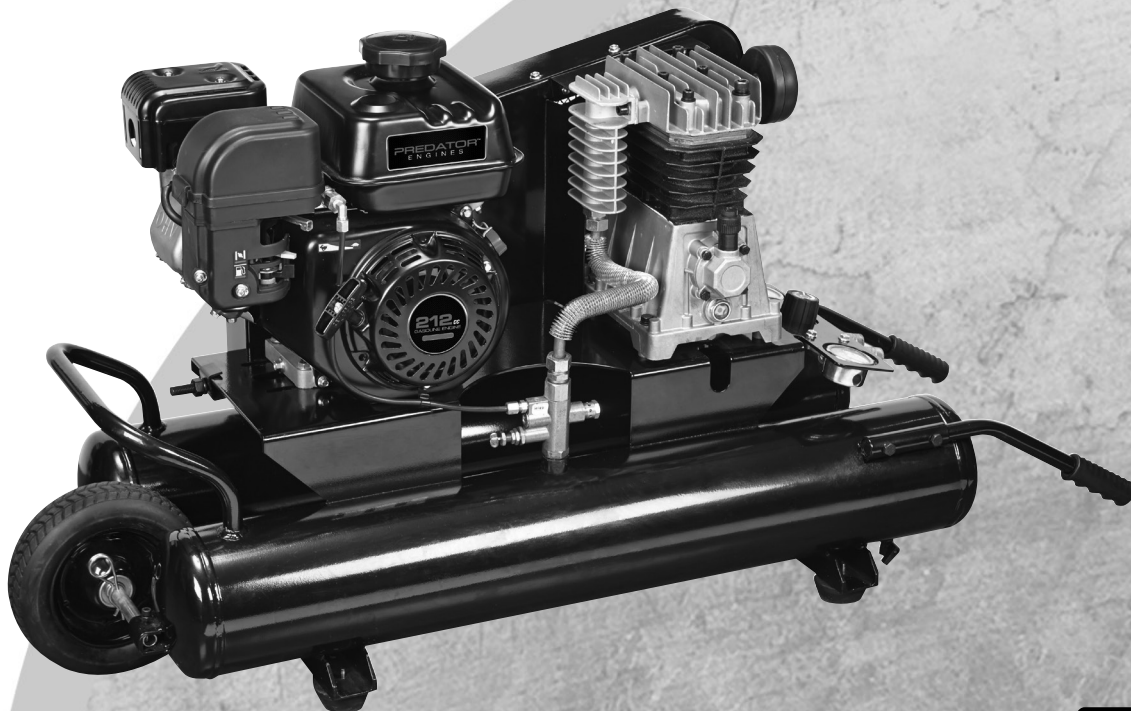

Visit our website at: <http://www.harborfreight.com>
Email our technical support at: productsupport@harborfreight.com

ITEM 62404

When unpacking, make sure that the product is intact and undamaged. If any parts are missing or broken, please call 1-888-866-5797 as soon as possible.

⚠ WARNING

Read this material before using this product. Failure to do so can result in serious injury. **SAVE THIS MANUAL.**

Copyright© 2014 by Harbor Freight Tools®. All rights reserved.
No portion of this manual or any artwork contained herein may be reproduced in any shape or form without the express written consent of Harbor Freight Tools. Diagrams within this manual may not be drawn proportionally. Due to continuing improvements, actual product may differ slightly from the product described herein. Tools required for assembly and service may not be included.

Table of Contents

Safety	2	Maintenance	14
Specifications	5	Parts List and Diagram	18
Setup	6	Warranty	20
Operation.....	10		





SAFETY

SETUP



OPERATION

MAINTENANCE

WARNING SYMBOLS AND DEFINITIONS

	This is the safety alert symbol. It is used to alert you to potential personal injury hazards. Obey all safety messages that follow this symbol to avoid possible injury or death.
	Indicates a hazardous situation which, if not avoided, will result in death or serious injury.
	Indicates a hazardous situation which, if not avoided, could result in death or serious injury.
	Indicates a hazardous situation which, if not avoided, could result in minor or moderate injury.
	Addresses practices not related to personal injury.

Symbol	Property or Statement
RPM	Revolutions Per Minute
HP	Horsepower
	WARNING marking concerning Risk of Eye Injury. Wear ANSI-approved safety goggles with side shields.

Symbol	Property or Statement
	WARNING marking concerning Risk of Respiratory Injury. Operate engine OUTSIDE and far away from windows, doors, and vents.
	WARNING marking concerning Risk of Explosion.

IMPORTANT SAFETY INFORMATION

General Safety Warnings

 **WARNING Read all safety warnings and instructions.**
Failure to follow the warnings and instructions may result in electric shock, fire and/or serious injury.
Save all warnings and instructions for future reference.

The warnings, precautions, and instructions discussed in this instruction manual cannot cover all possible conditions and situations that may occur. It must be understood by the operator that common sense and caution are factors which cannot be built into this product, but must be supplied by the operator.

Set up Precautions

1. Gasoline fuel and fumes are flammable, and potentially explosive. Use proper fuel storage and handling procedures. Do not store fuel or other flammable materials nearby.
2. Have multiple ABC class fire extinguishers nearby.
3. Operation of this equipment may create sparks that can start fires around dry vegetation. A spark arrestor may be required. The operator should contact local fire agencies for laws or regulations relating to fire prevention requirements.
4. Set up and use only on a flat, level, well-ventilated surface.
5. Use only lubricants and fuel recommended in the engine manual or in the Specifications chart of this manual.
6. Wear ANSI-approved safety goggles, heavy-duty work gloves, and dust mask/respirator during set up.

Engine Precautions

Follow engine precautions and instructions in the included engine instruction manual.

Operating Precautions

1.  **CARBON MONOXIDE HAZARD**
Using an engine indoors CAN KILL YOU IN MINUTES.
Engine exhaust contains carbon monoxide. This is a poison you cannot see or smell.

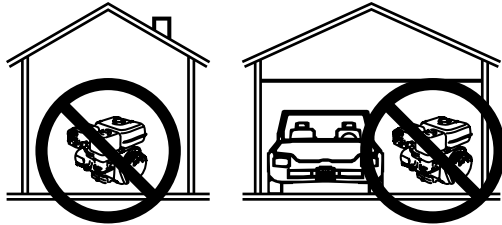

NEVER use inside a home or garage, EVEN IF doors and windows are open.

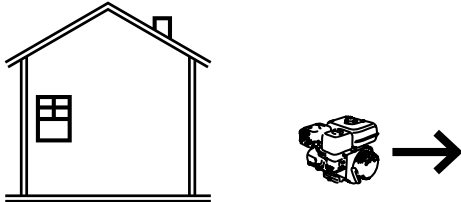

Only use OUTSIDE and far away from windows, doors, and vents.

- Keep children away from the equipment, especially while it is operating.
- Fire Hazard! Do not fill gas tank while Compressor engine is running. Do not operate if gasoline has been spilled. Clean spilled gasoline before starting engine. Do not operate near pilot light or open flame.
- Do not touch Compressor engine during use. Let engine cool down after use.
- Never store fuel or other flammable materials near the Compressor engine.
- Only use a suitable means of transport and lifting devices with sufficient weight bearing capacity when transporting the Compressor.
- Secure the Compressor on transport vehicles to prevent the tool from rolling, slipping, and tilting.
- Industrial applications must follow OSHA requirements.
- Do not leave the equipment unattended when it is running. Turn off the equipment (and remove safety keys, if available) before leaving the work area.
- Wear ANSI-approved safety glasses, hearing protection, and NIOSH-approved dust mask/respirator under a full face shield along with steel-toed work boots during use.
- People with pacemakers should consult their physician(s) before use. Electromagnetic fields in close proximity to a heart pacemaker could cause pacemaker interference or pacemaker failure. Caution is necessary when near the engine's magneto or recoil starter.
- Use only accessories that are recommended by Harbor Freight Tools for your model. Accessories that may be suitable for one piece of equipment may become hazardous when used on another piece of equipment.
- Do not operate in explosive atmospheres, such as in the presence of flammable liquids, gases, or dust. Gasoline-powered engines may ignite the dust or fumes.
- Stay alert, watch what you are doing and use common sense when operating this piece of equipment. Do not use this piece of equipment while tired or under the influence of drugs, alcohol or medication.
- Do not overreach. Keep proper footing and balance at all times. This enables better control of the equipment in unexpected situations.
- Dress properly. Do not wear loose clothing or jewelry. Keep hair, clothing and gloves away from moving parts. Loose clothes, jewelry or long hair can be caught in moving parts.
- Parts, especially exhaust system components, get very hot during use. Stay clear of hot parts.
- Do not cover the engine or equipment during operation.
- Keep the equipment, engine, and surrounding area clean at all times.
- Use the equipment, accessories, etc., in accordance with these instructions and in the manner intended for the particular type of equipment, taking into account the working conditions and the work to be performed. Use of the equipment for operations different from those intended could result in a hazardous situation.
- Do not operate the equipment with known leaks in the engine's fuel system.
- WARNING:** This product contains or, when used, produces a chemical known to the State of California to cause cancer and birth defects or other reproductive harm. (California Health & Safety Code § 25249.5, *et seq.*)

Operating Precautions (cont'd)

23. **WARNING:** The brass components of this product contain lead, a chemical known to the State of California to cause cancer and birth defects or other reproductive harm. (California Health & Safety Code § 25249.5, *et seq.*)
24. When spills of fuel or oil occur, they must be cleaned up immediately. Dispose of fluids and cleaning materials as per any local, state, or federal codes and regulations. Store oil rags in a bottom-ventilated, covered, metal container.
25. Keep hands and feet away from moving parts. Do not reach over or across equipment while operating.
26. Before use, check for misalignment or binding of moving parts, breakage of parts, and any other condition that may affect the equipment's operation. **If damaged, have the equipment serviced before using.** Many accidents are caused by poorly maintained equipment.
27. Use the correct equipment for the application. Do not modify the equipment and do not use the equipment for a purpose for which it is not intended.

Service Precautions

1. **Before service, maintenance, or cleaning:**
 - a. Turn the engine switch to its "OFF" position.
 - b. Allow the engine to completely cool.
 - c. Then, remove the spark plug cap from the spark plug.
2. Keep all safety guards in place and in proper working order. Safety guards include muffler, air cleaner, mechanical guards, and heat shields, among other guards.
3. **Do not alter or adjust any part of the equipment or its engine that is sealed by the manufacturer or distributor. Only a qualified service technician may adjust parts that may increase or decrease governed engine speed.**
4. Wear ANSI-approved safety goggles, heavy-duty work gloves, and dust mask/respirator during service.
5. Maintain labels and nameplates on the equipment. These carry important information. If unreadable or missing, contact Harbor Freight Tools for a replacement.
6. Have the equipment serviced by a qualified repair person using only identical replacement parts. This will ensure that the safety of the equipment is maintained. Do not attempt any service or maintenance procedures not explained in this manual or any procedures that you are uncertain about your ability to perform safely or correctly.
7. Store equipment out of the reach of children.
8. Follow scheduled engine and equipment maintenance.

Air Compressor Safety Warnings

1. Risk of fire or explosion - Do not spray flammable liquid in a confined area or towards a hot surface. Spray area must be well-ventilated. Do not smoke while spraying or spray where spark or flame is present. Arcing parts - Keep compressor at least 20 feet away from explosive vapors, such as when spraying with a spray gun.
2. Risk of bursting - Do not adjust regulator higher than maximum stated pressure of attachment.
3. Risk of injury - Do not direct air stream at people or animals.
4. Do not use to supply breathing air.
5. Do not use the air hose to move the compressor.
6. Drain Tanks daily and after use. Internal rust causes tank failure and explosion.
7. **Add correct amount of compressor oil before first use and every use. Operating with the incorrect amount of oil causes permanent damage and voids warranty. To prevent damage, do not use with overfilled or low oil.**
8. Compressor head gets hot during operation. Do not touch it or allow children nearby during or immediately following operation.
9. Release the pressure in the storage tanks before moving.
10. The use of accessories or attachments not recommended by the manufacturer may result in a risk of injury to persons.
11. All air line components, including hoses, pipe, connectors, filters, etc., must be rated for a minimum working pressure of 125 PSI, or 150% of the maximum system pressure, whichever is greater.



SAVE THESE INSTRUCTIONS.

Specifications

Air Outlet Size	2 Male 1/4" -18 NPT	Compressor Oil Type	SAE 30W non-detergent Air Compressor Oil (Item 68097, sold separately)
Air Pressure	Auto Shut-Off @ 135 PSI Restart @ 105 PSI	Required Rotation viewed from PTO (power takeoff - the output shaft)	Counterclockwise
Air Tank Capacity	9 Gallons	Required Engine Idle Speed	2260 RPM ± 100 RPM
Air Flow Capacity	9 CFM @ 90 PSI 11 CFM @ 40 PSI		
Compressor Oil Capacity	27 oz. (0.8L)		

Note: Engine specifications are found in the engine manual supplied with this equipment.

Engine Controls

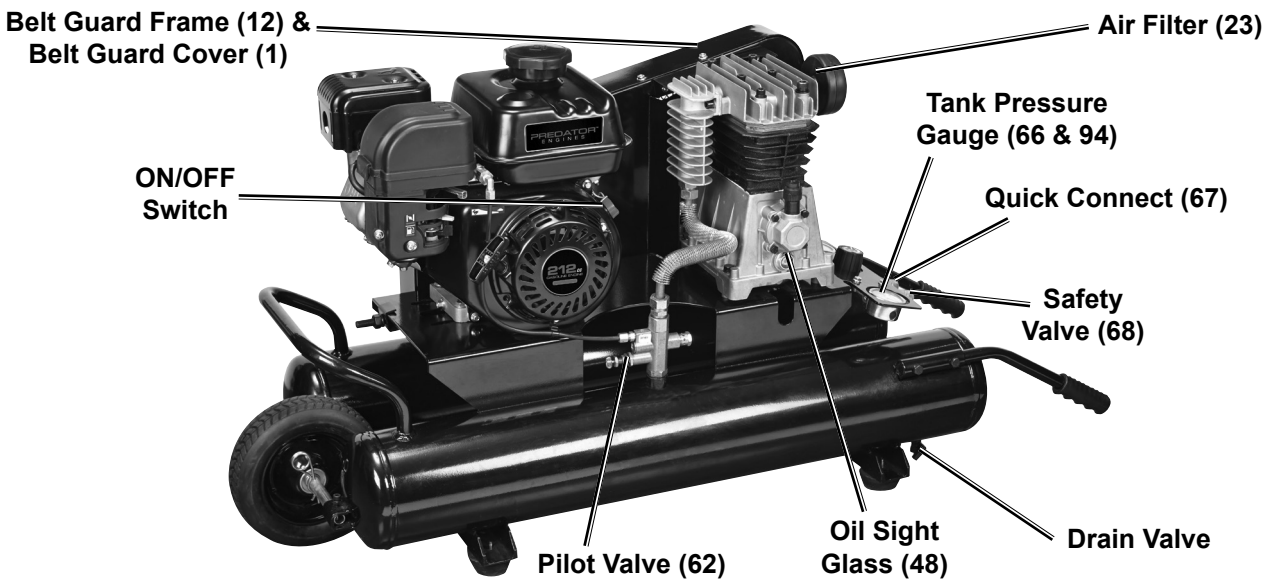

- Belt Guard** - The Belt Guard encloses the pulleys and drive belts. It protects the user from the moving parts and allows the large pulley to direct cooling air to the Air Pump.
- Oil Sight Glass** - The oil sight glass shows proper level of the oil. Oil level should be at center of Sight Glass.
- Tank Drain Valves** - The Air Tank Drain Valves allow moisture to be removed from the tanks to prevent corrosion.
- Safety Valve** - The Safety Valve automatically releases air if the Air Tank pressure exceeds the preset maximum. In an emergency, the ring can be pulled to relieve tank air pressure. There is one safety valve on the pump and one on the pneumatic assembly.
- Air Outlet** - An air hose attaches to this valve. Air pressure required by tools is set by an air pressure regulator.
- Air Storage Tanks** - The Air Tanks are where air pressurized by the Air Pump is stored for use.
- Tank Pressure Gauge** - The Air Tank Pressure Gauge displays the air pressure in the tank.
- Pilot Valve** - Open the Pilot Valve before starting the engine. It relieves resistance on the engine to make starting possible. Rotate the pin so it is vertical to open it. Once the engine is running, close the Pilot Valve so the Compressor can build up pressure.

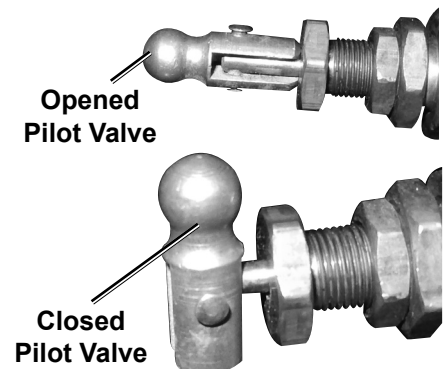
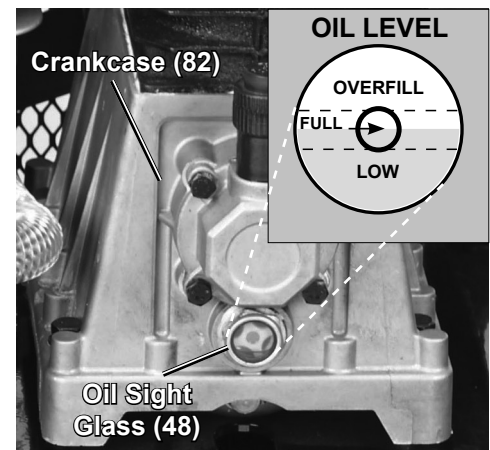

SAFETY

SETUP

OPERATION

MAINTENANCE

Setup

The emission control system for this Compressor's Engine is warranted for standards set by the U.S. Environmental Protection Agency and by the California Air Resources Board (also known as CARB). For warranty information, refer to the engine manual.

Install the Wheel

1. Position an Axle Washer on each side of the Tire (57).
2. Slide the Front Axle through the Axle Washers and Wheel.
3. Attach the Axle and Wheel Assembly to the frame. Tighten securely.
4. Check the Wheel for proper function.
5. Check the Wheel air pressure, and fill to no more than 36 PSI.

Install the Handles

1. Insert each of the two Handles into the Handle Brackets on the side of each Air Tank.
2. Secure each Handle in place using Bolt (72), Washers. Tighten securely.
3. Install the Handle Grips (76) on each Handle.
4. Recheck all bolts and fasteners periodically during work to ensure the assembly remains secure and safe.

Air Filter Assembly

To install the Air Filter (23), fit the Filter Connecting Tube (24) into the Filter. Keeping the Seal (25) between them, slide the assembly into the hole on the side of the Cylinder Cap (35). Secure in place with two Screws (22). See Figure A.

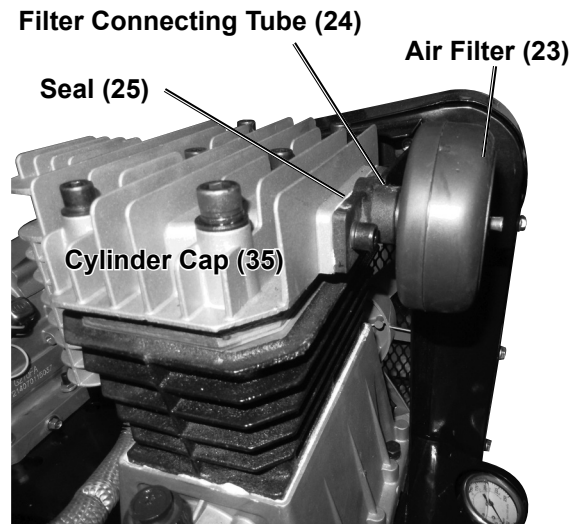

Figure A

CENTRALPNEUMATIC®

Break-In Compressor

Break in the new Air Compressor as follows:

- a. Make sure the engine is off. Open the air outlet valve. If the air outlet has a quick coupler valve, insert a male coupler into it to open it.
- b. Check all fluid levels in the engine and pump.
- c. Start the engine following the General Operating Instructions.
- d. Let the unit run for 30 minutes. Air will expel freely through the Coupler.
- e. Turn OFF the engine.
- f. Remove the male coupler.

Connection

1. Connect a regulator valve, an in-line shut off valve and a 1/2" NPT air hose (all sold separately) to the Quick Coupler. The air hose must be long enough to reach the work area with enough extra length to allow free movement while working.
 2. Depending on the tool which you will be using with this compressor, you may need to incorporate additional components, such as an in-line oiler, a filter, or a dryer (all sold separately). Consult your air tool's manual for needed accessories. See Typical Air Line Setup charts on the following pages. This is a truckbed compressor, so use the portable setup as a model.
- Note:** An in-line shutoff ball valve is an important safety device because it controls the air supply even if the air hose is ruptured. The shutoff valve should be a ball valve because it can be closed quickly.

CENTRALPNEUMATIC®

Figure B: Portable Air Supply Setup

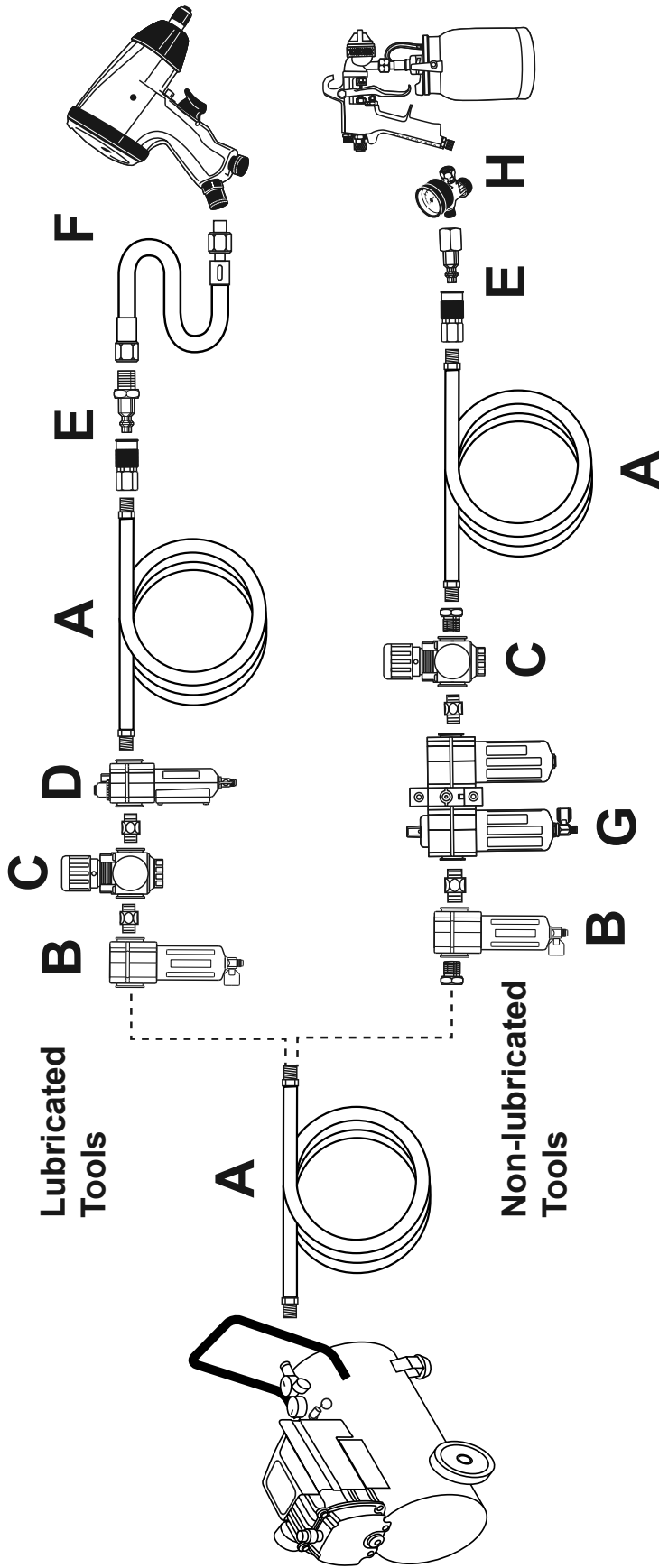

Description	Function
A Air Hose	Connects air to tool
B Filter	Prevents dirt and condensation from damaging tool or work piece
C Regulator	Adjusts air pressure to tool
D Lubricator (optional)	For air tool lubrication
E Coupler and Plug	Provides quick connection and release
F Leader Hose (optional)	Increases coupler life
G Air Cleaner / Dryer (optional)	Prevents water vapor from damaging work piece
H Air Adjusting Valve (optional)	For fine tuning airflow at tool

Figure C: Stationary Air Supply Setup

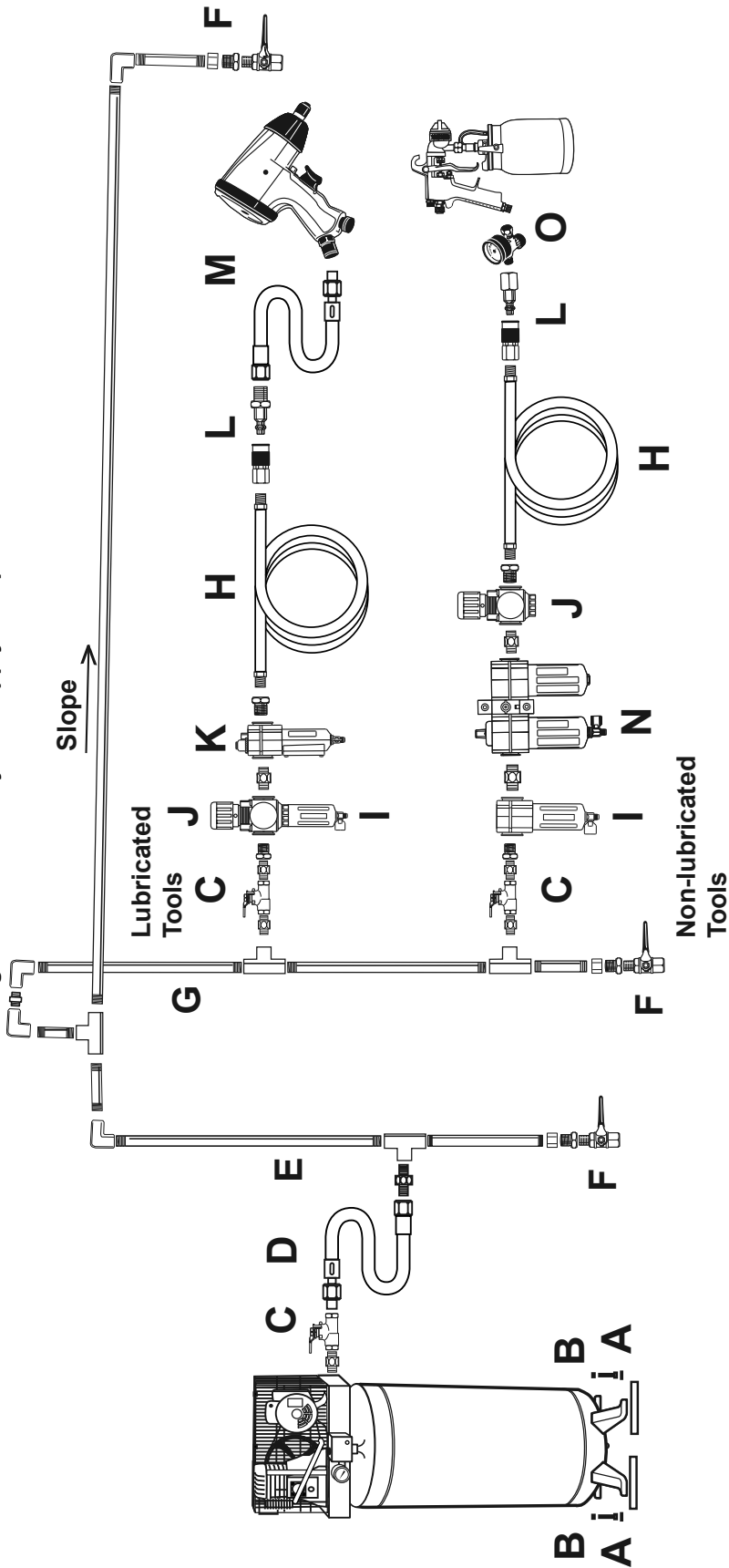

	Description	Function
A	Vibration Pads	For noise and vibration reduction
B	Anchor Bolts	Secures air compressor in place
C	Ball Valve	Isolates sections of system for maintenance
D	Isolation Hose	For vibration reduction
E	Main Air Line - 3/4" minimum recommended	Distributes air to branch lines
F	Ball Valve	To drain moisture from system
G	Branch Air Line - 1/2" minimum recommended	Brings air to point of use
H	Air Hose	Connects air to tool
I	Filter	Prevents dirt and condensation from damaging tool or work piece
J	Regulator	Adjusts air pressure to tool
K	Lubricator (optional)	For air tool lubrication
L	Coupler and Plug	Provides quick connection and release
M	Leader Hose (optional)	Increases coupler life
N	Air Cleaner / Dryer (optional)	Prevents water vapor from damaging work piece
O	Air Adjusting Valve (optional)	For fine tuning airflow at tool

Operation



Read the **ENTIRE IMPORTANT SAFETY INFORMATION** section at the beginning of this manual including all text under subheadings therein before set up or use of this product.

Using the Compressor

Inspect Compressor, engine, pump and equipment looking for damaged, loose, and missing parts before set up and starting. If any problems are found, do not use equipment until fixed properly.

Note: At the beginning of the day's first use of the Air Compressor, check for air leaks by applying soapy water to connections while the Air Compressor is pumping and after pressure cut-out. Look for air bubbles. If air bubbles are present at connections, tighten connections. Do not use the air compressor unless all connections are air tight. The extra air leaking out will cause the compressor to operate too often, increasing wear on the compressor.

Before starting the Compressor:



- Follow the Set Up Instructions in the equipment manual to prepare the equipment.
- Follow the Set Up Instructions in the Engine manual to prepare the engine.
- Inspect all components of the setup. Make sure all nuts and bolts are tight.
- Fill the Engine with the proper amount and type of both fuel and oil.
- Fill the Compressor Pump with compressor oil following the Maintenance Instructions in this manual.

To Start and Use the Compressor

1. Close the Drain Valves by turning the levers up so that they are perpendicular to the valve.

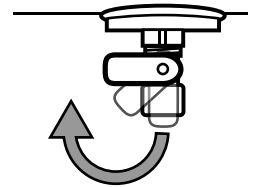
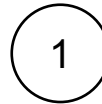

2. Open the Pilot Valve by rotating it to a vertical position.

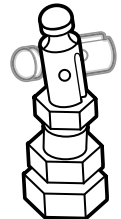
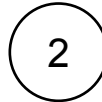

3. Open the Fuel Valve.

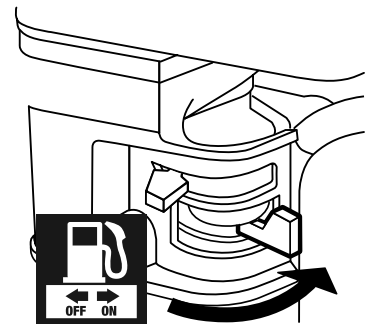
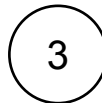

CENTRALPNEUMATIC®

Using the Compressor (cont'd)

4. To start a cold engine, move the Choke to the CHOKE (start/closed) position.
To restart a warm engine, leave the Choke in the RUN position.

4

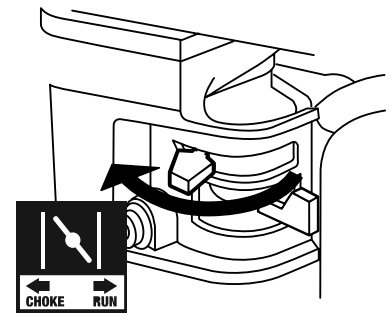

5. Turn the Engine Switch to ON.

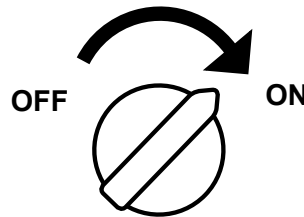

5

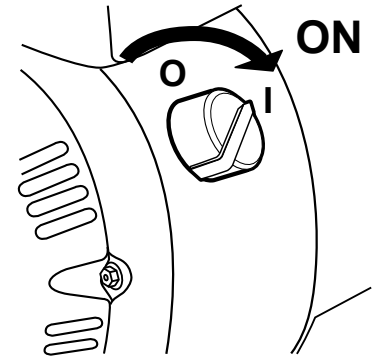

6. Grip the Starter Handle of the Engine loosely and pull it slowly several times to allow the gasoline to flow into the Engine's carburetor. Then pull the Starter Handle gently until resistance is felt. Allow Cable to retract fully and then pull it quickly. Repeat until the engine starts.

6

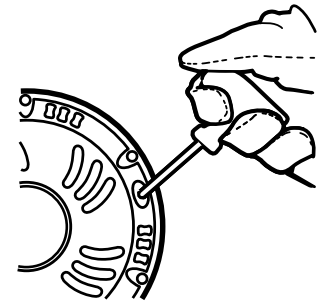

Note: Do not let the Starter Handle snap back against the engine. Hold it as it recoils so it doesn't hit the engine.

Note: If engine does not start, check engine oil. Engine will not start with low or no engine oil.

7. Allow the Engine to run for several seconds.
Then, if the Choke lever is in the CHOKE position, move the Choke Lever very slowly to its RUN position.

7

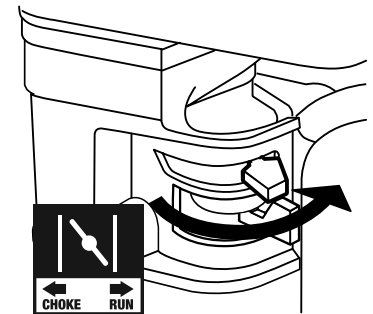

8. Close the Pilot Valve by rotating it to a horizontal position.

8

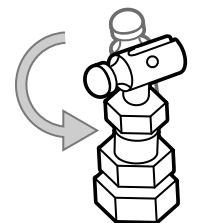

CENTRALPNEUMATIC®

SAFETY

SETUP

OPERATION

MAINTENANCE

Using the Compressor (cont'd)

9. When the Gas Engine is started and running, the compressor Pump starts compressing air into the Air Tank. Open the in-line Shutoff Valve and adjust the Pressure Regulator (sold separately) so that the air output is enough to properly power the tool, but the output will not exceed the tool's maximum air pressure at any time. Turn the knob clockwise to increase the pressure and counterclockwise to decrease pressure. Adjust the pressure gradually, while checking the air output gauge to set the pressure.

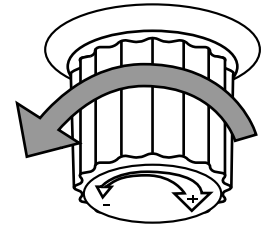
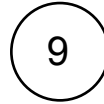

IMPORTANT: Allow the engine to run for five minutes with no load after each start-up so that the engine can stabilize.

10. Adjust the Throttle as needed.

11. **Break-in Period:**

- a. Breaking-in the engine will help to ensure proper equipment and engine operation.
- b. The operational break-in period will last about 3 hours of use. During this period:
 - Do not apply a heavy load to the equipment.
 - Do not operate the engine at its maximum speed.
- c. The maintenance break-in period will last about 20 hours of use. After this period:
 - Change the engine oil.

Under normal operating conditions subsequent maintenance follows the schedule explained in the MAINTENANCE AND SERVICING section.

Note: When maximum tank pressure is reached, the compressor automatically disengages, and the engine RPM drops down to idle speed. The engine remains at idle until Air Tank pressure falls to a preset level. The Gas Engine will then accelerate and air pressure once again begins to build up in the Air Tank.

Note: As long as the engine is running, the operation of the Air Compressor is automatic, controlled by an internal pressure switch.

IMPORTANT: The internal pressure switch is not user adjustable; **do not make changes to the air pressure settings of the internal pressure switch.** Any change to the automatic pressure levels may cause excess pressure to accumulate, causing a hazardous situation.

Note: Depressurization - If it is necessary to quickly *depressurize* the Compressor, turn OFF the engine. Then, pull on the ring on the tank Safety Valve to release stored air pressure.

12. Use the air tool as needed.

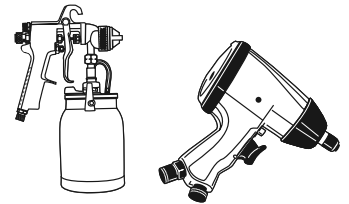
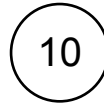

CENTRALPNEUMATIC®

Using the Compressor (cont'd)

13. To stop the engine in an emergency, turn the Engine Switch off.

11

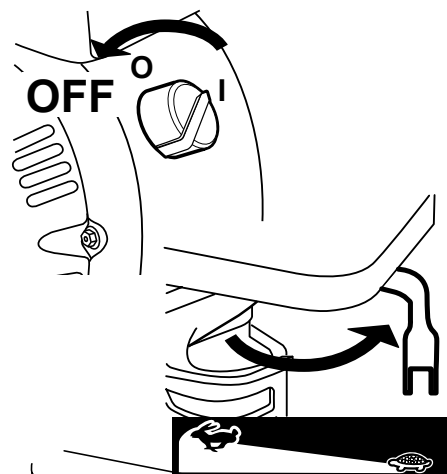

Under normal conditions, use the following procedure:

- Slide the Throttle or Speed Control Lever to SLOW (the "turtle").
- Turn the Engine Switch off.
- Close the Fuel Valve.

WARNING! The fuel valve must be closed before moving the engine to prevent fuel leakage and fire.

14. Bleed air from the tool, then disconnect the tool.

12

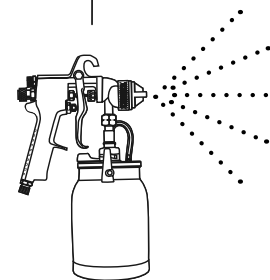

15. Open the Drain Valve at the bottom of the Tank, to release any built-up moisture and the internal tank pressure.

13

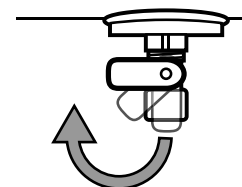

16. Clean, then store the Air Compressor indoors.

SAFETY

SETUP

OPERATION

MAINTENANCE

CENTRALPNEUMATIC®

⚠ WARNING**TO PREVENT SERIOUS INJURY FROM ACCIDENTAL STARTING:**

Turn the Power Switch of the equipment to its "OFF" position, release tank air pressure, wait for the engine to cool, and disconnect the spark plug cap before performing any inspection, maintenance, or cleaning procedures.

TO PREVENT SERIOUS INJURY FROM EQUIPMENT FAILURE:

Do not use damaged equipment. If abnormal noise, vibration, or excess smoking occurs, have the problem corrected before further use.

Follow all service instructions in this manual. The engine may fail critically if not serviced properly.



Many maintenance procedures, including any not detailed in this manual, will need to be performed by a qualified technician for safety. If you have any doubts about your ability to safely service the equipment or engine, have a qualified technician service the equipment instead.

Compressor Pump Oil Maintenance

Check oil periodically for clarity. Replace oil if it appears milky or if debris is present, or every 6 months, or 100 hours of runtime, whichever comes first. In harsh environments such as high heat or high humidity, you will need to replace the oil more frequently.

Change the compressor oil after the first hour of use to remove any debris.

Adding Oil

- The oil level should be at the center of the "full" level on the Oil Sight Glass, as shown above. Add oil as needed to maintain this level. Do not let the oil level go below the center dot (LOW as shown above) and do not overfill the oil so that it is above the center dot (OVERFILL as shown above) on the Oil Sight Glass. See "Figure D" on page 14.
 - Using a funnel to avoid spills, pour enough oil into the pump Crankcase to reach the "full" level in the Oil Sight Glass.
 - Replace the Oil Plug.

Cold Weather Operation

Premium quality 30-weight, non-detergent air compressor oil (sold separately) is recommended for use with this compressor. Start compressor in heated area if outdoor temperatures drop below 32° F. If this is not practical, drain out the old pump oil and use SAE 10W Non-detergent Air Compressor Oil in the pump crankcase instead whenever the compressor's temperature will fall below 40°. Do not use multi-viscosity oil (such as 10W-30), they leave carbon deposits on pump components and lead to accelerated failure. Heavy operation may require heavier viscosity oil.

- If uncertain which oil to use for this compressor, please call Harbor Freight Tools customer service at 1-888-866-5797 for assistance.

WARNING! To prevent serious injury from burns: Do not add or change the oil while the compressor is in operation. Allow the compressor to cool before replacing oil.

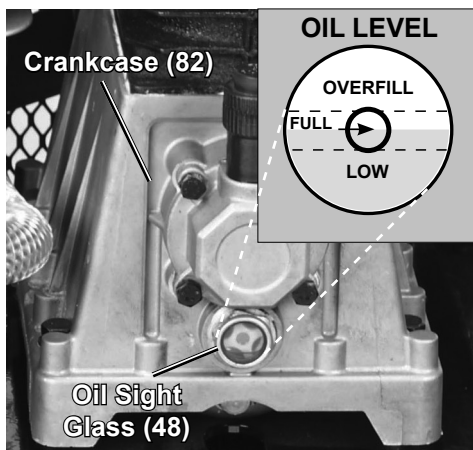

Figure D

- To add oil:
 - Remove the Oil Breather (55).

Changing Oil

1. Place a container under the Drain Plug.
2. Remove the Oil Plug to allow air flow into the Pump.
3. Remove the Drain Plug, allowing the oil to drain into the container.
4. When the oil is completely drained from the Pump, replace the Drain Plug.
5. Fill the Pump with new compressor oil to the FULL level on the Oil Sight Glass.
6. Replace and tighten the Oil Plug.
7. Discard the old oil according to local, state and federal regulations.

Draining Moisture from the Tanks

The Drain Valves are located under the Tanks. They must be accessed daily to release all trapped air and moisture from the Tanks. This will eliminate condensation which can cause tank corrosion. To empty the air and condensation:

1. Make sure the compressor engine is off.
2. Place a collection pan under the Drain Valves.
3. Open the Drain Valves by pivoting the lever on the bottom of the Compressor so the lever is in line with the Drain Valves.
4. When all the pressure is released, close the Drain Valves by pivoting the lever on the bottom of the compressor so that the lever is perpendicular to the Drain Valve.

Air Filter Maintenance

Check the Air Filter weekly to see if it needs replacement. If working in dirty environments, you may need to clean the filter more often. To clean the Air Filter:

1. Unthread the Wing Nut holding the Air Filter Assembly in place.
2. Remove the air filter cover and the air filter elements and check for dirt. Clean or replace as described below.
3. **Cleaning:**
 - For “paper” filter elements:
To prevent injury from dust and debris, wear ANSI-approved safety goggles, NIOSH-approved dust mask/respirator, and heavy-duty work gloves. In a well-ventilated area away from bystanders, use pressurized air to blow dust out of the air filter. If this does not get the filter clean, replace it.
 - For foam filter elements:
Wash the element in warm water and mild detergent several times. Rinse. Squeeze out excess water and allow it to dry completely. Soak the filter in lightweight oil briefly, then squeeze out the excess oil.
4. Install the cleaned filter. Secure in place with the Wing Nut.

Adjusting Belt Tension

SAFETY

1. Remove the Belt Guard Cover (1) and set it aside.
2. Press on the center of the longest span on each belt with moderate finger pressure (4-4.5 lb). Then measure the deflection distance, the distance that the belt moved. The belt should deflect anywhere from 1/2" to 1".

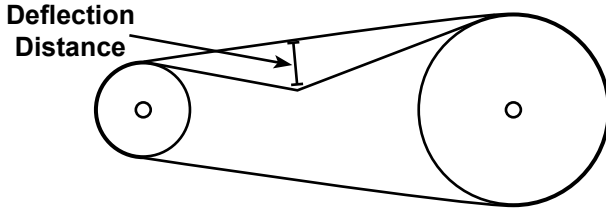

3. **If either belt deflects too much**, tighten belts by loosening the four Engine Mounting Bolts and moving the engine away from the other pulley slightly by turning the Nut (93) holding the Brace Rod (91). Secure engine mounting bolts and retest tension. If either belt is too long to be properly tensioned, both belts must be replaced. See Figure E.

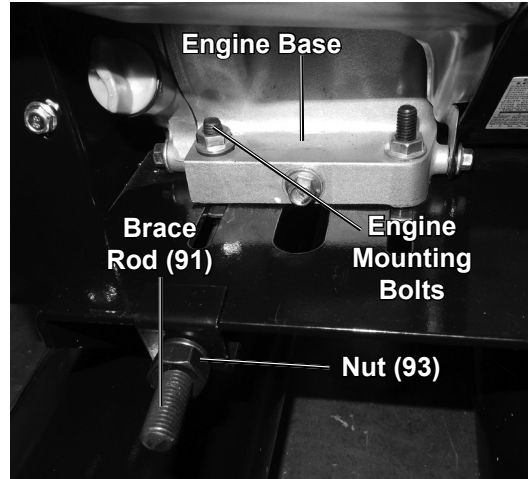

Figure E

4. **If either belt deflects too little**, loosen belts by loosening the Bolts on the Bottom Plate and moving the engine towards the other pulley slightly by turning the Nut (93) on the Brace Rod (91). Secure engine mounting bolts and retest tension.
5. Before use, replace belt cover.

SETUP

OPERATION

MAINTENANCE

Troubleshooting

Problem	Possible Causes	Likely Solutions
Engine will not start (Note: See engine manual for engine specific issues.)	COMPRESSOR SPECIFIC: Pilot Valve closed.	COMPRESSOR SPECIFIC: Open pilot valve before start procedure, close after unit is running.
Compressor overheats	1. Incorrect lubrication or not enough lubrication. 2. Worn parts.	1. Lubricate using recommended oil or grease according to directions. 2. Have qualified technician inspect internal mechanism and replace parts as needed.
Severe air leakage	1. Poor air outlet seal. 2. Loose cylinder/cylinder head. 3. Damaged valve or housing. 4. Dirty, worn or damaged valve.	1. Tighten or re-attach using thread seal tape. 2. Tighten cylinder/cylinder head assembly. If cylinder/cylinder head cannot tighten properly, internal parts may be misaligned. 3. Replace damaged components. 4. Clean or replace valve assembly.
Unit stalls	1. Low engine idle. 2. Severely clogged air filter. 3. Improper lubrication. 4. Defective pilot/unloader valve.	1. Qualified technician should increase idle to 2,200±100 RPM by adjusting pressure switch. 2. Replace air filter. 3. Check for proper oil level. 4. Replace pilot valve.
Excessive noise	1. Loose drive pulley or flywheel. 2. Misaligned pulleys. 3. Lack of oil in crankcase. 4. Worn connecting rod. 5. Worn wrist pin bushing. 6. Worn bearings. 7. Loose belts.	1. Loose pulleys are a common cause of "knocking". Tighten appropriate bolts. 2. Align pulleys with straightedge and secure in place. 3. Check for proper oil level. 4. Replace connecting rod. 5. Remove piston assembly and replace necessary parts. 6. Replace bearings and oil. 7. Check for proper belt tension.
Oil in the discharge air	1. Wrong type of oil or low-quality oil. 2. Overheating. 3. Restricted intake air. 4. Worn piston rings. 5. Excessive moisture in the tank.	1. Change oil. Check oil recommendations under EQUIPMENT SET UP, Equipment Oil Fill section of this manual. 2. See above Excessive Noise section. 3. Clean or replace air filter. 4. Replace piston rings. 5. Drain moisture from the tank daily.
Low discharge pressure	1. Air leaks. 2. Leaking valves. 3. Restricted air intake. 4. Blown gaskets. 5. Slipping belts.	1. Listen for escaping air. Apply soap solution to all fittings and connections. Bubbles will appear at points of leakage. Tighten or replace leaking fittings or connections. 2. Remove head and inspect for valve breakage, weak valves, scored valve plate, etc. Replace defective parts and reassemble. Replace head gasket each time the head is removed. 3. Clean or replace air filter element. 4. Replace and gaskets proven faulty on inspection. 5. Tighten Belts (See monthly maintenance.)



Follow all safety precautions whenever diagnosing or servicing the equipment or engine.

SAFETY

SETUP

OPERATION

MAINTENANCE

Parts List and Diagram

Parts List

Part	Description	Qty
1	Belt Guard Cover	1
2	Screw M8x20	1
3	Screw M8x30	1
4	Washer 8	2
5	Bushing	1
6	Flat Key	1
7	Drive Pulley	1
8	Driven Pulley	1
9	Belt	1
10	Flat Washer 6	16
11	Bolt M6x12	16
12	Belt Guard Frame	1
13	Restrictive Block	1
14	Pull Block	1
15	Crank Shaft	1
16	Connecting Rod	2
17	Piston	2
18	Piston Pin	2
19	Closing Ring	4
20	Piston Ring	2
21	Taper-Face Ring	2
22	Screw M8x20	4
23	Air Filter	1
24	Filter Connecting Tube	1
25	Seal	1
26	Washer	6
27	Socket Head Cap Screw M8x60	6
28	Paper Washer	1
29	Radiator	1
30	Connector	1
31	Taper Sleeve	2
32	Nut	2
33	Brass Tube	1
34	Cooling Fins	1
35	Cylinder Cap	1
36	Gasket	1
37	Upper Valve Plate	1
38	Metal Gasket	1
39	Valve	4
40	Lower Valve Plate	1
41	Cylinder	1
42	Gasket	1
43	Bolt M8x60	4
44	Washer	4
45	Bearing	2
46	End Cap Gasket	2
47	Oil Breather Cover	1

Part	Description	Qty
48	Oil Sight Glass	1
49	Washer	1
50	Seal	1
51	Oil Pan	1
52	Screw M5x16	14
53	Screw M6x16	8
54	Spring Washer 6	8
55	Oil Breather	1
56	Engine	1
57	Tire	1
58	Screw M6x20	2
59	Clip	2
60	Wheel Supporting Tube	1
61	Throttle Control Valve	1
62	Pilot Valve	1
63	Elbow	1
64	Bolt M6x16	4
65	Pneumatic Combination	1
66	Tank Pressure Gauge	1
67	Quick Connector	2
68	Safety Valve	1
69	Discharge Tube	1
70	Taper Sleeve	2
71	3/8 Pipe Nut	2
72	Bolt M8x20	4
73	Closing Ring	2
74	Tank Assy.	1
75	Handle	2
76	Rubber Handgrip	2
77	Screw M6x20	4
78	Flat Washer	4
79	Rubber Foot	4
80	Gasket	1
81	Elbow	1
82	Crank Case	1
83	Oil Seal Ø40mmxØ25mm	1
84	O-Ring Ø14.3xØ2.5	1
85	Drain Bolt	1
86	Crankcase End Cover	1
87	Wiper Ring	2
88	Bushing	1
89	Bolt M8x35	1
90	Bolt M8x20	6
91	Brace Rod	1
92	U Shape Part	1
93	Nut M12	1
94	Tank Pressure Gauge	1

Record Product's Serial Number Here: _____

Note: If product has no serial number, record month and year of purchase instead.

Note: Some parts are listed and shown for illustration purposes only, and are not available individually as replacement parts.

Assembly Diagram

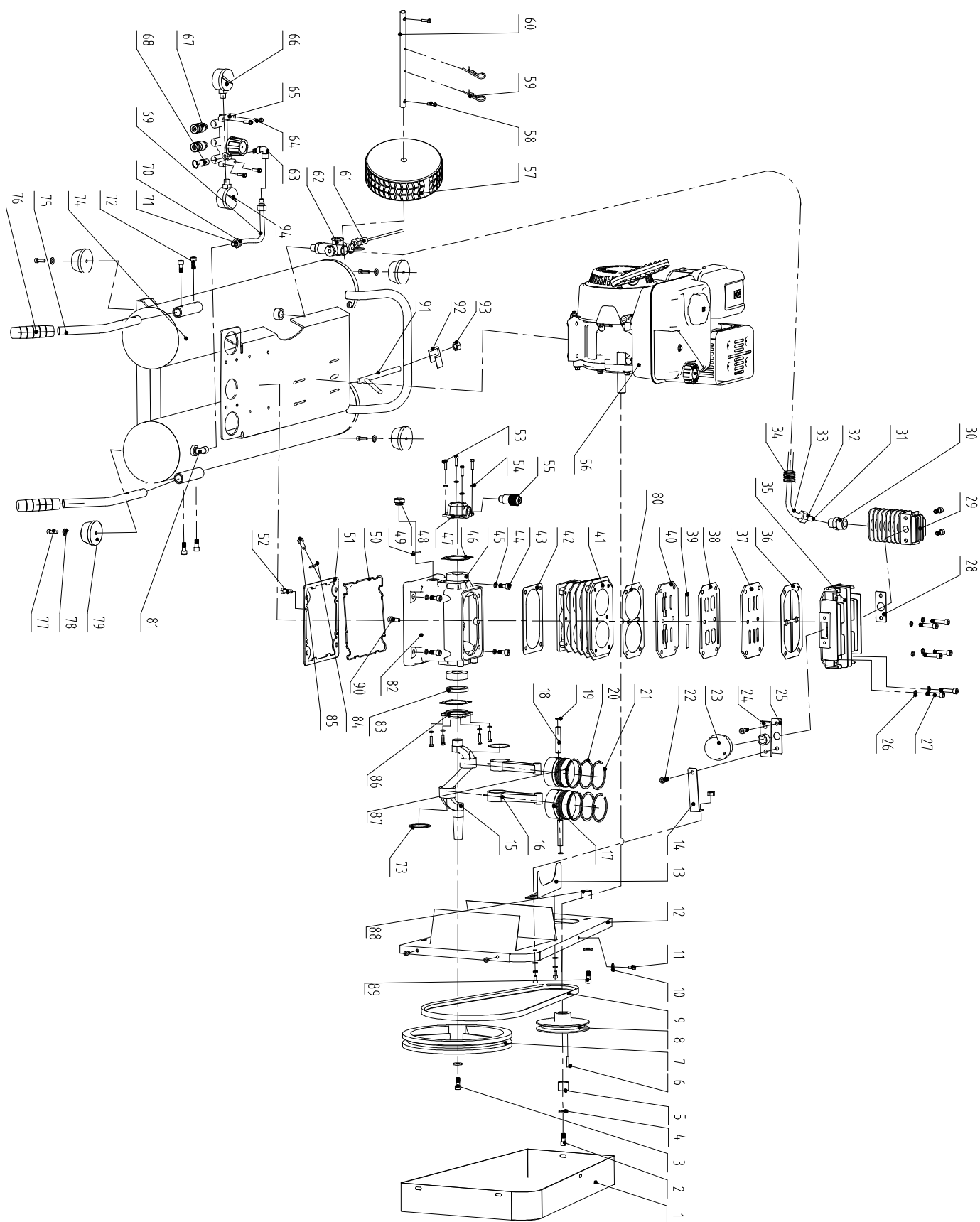

SAFETY

SETUP

OPERATION

MAINTENANCE

PLEASE READ THE FOLLOWING CAREFULLY

THE MANUFACTURER AND/OR DISTRIBUTOR HAS PROVIDED THE PARTS LIST AND ASSEMBLY DIAGRAM IN THIS MANUAL AS A REFERENCE TOOL ONLY. NEITHER THE MANUFACTURER OR DISTRIBUTOR MAKES ANY REPRESENTATION OR WARRANTY OF ANY KIND TO THE BUYER THAT HE OR SHE IS QUALIFIED TO MAKE ANY REPAIRS TO THE PRODUCT, OR THAT HE OR SHE IS QUALIFIED TO REPLACE ANY PARTS OF THE PRODUCT. IN FACT, THE MANUFACTURER AND/OR DISTRIBUTOR EXPRESSLY STATES THAT ALL REPAIRS AND PARTS REPLACEMENTS SHOULD BE UNDERTAKEN BY CERTIFIED AND LICENSED TECHNICIANS, AND NOT BY THE BUYER. THE BUYER ASSUMES ALL RISK AND LIABILITY ARISING OUT OF HIS OR HER REPAIRS TO THE ORIGINAL PRODUCT OR REPLACEMENT PARTS THERETO, OR ARISING OUT OF HIS OR HER INSTALLATION OF REPLACEMENT PARTS THERETO.

Limited 90 Day Warranty

Harbor Freight Tools Co. makes every effort to assure that its products meet high quality and durability standards, and warrants to the original purchaser that this product is free from defects in materials and workmanship for the period of 90 days from the date of purchase. This warranty does not apply to damage due directly or indirectly, to misuse, abuse, negligence or accidents, repairs or alterations outside our facilities, criminal activity, improper installation, normal wear and tear, or to lack of maintenance. We shall in no event be liable for death, injuries to persons or property, or for incidental, contingent, special or consequential damages arising from the use of our product. Some states do not allow the exclusion or limitation of incidental or consequential damages, so the above limitation of exclusion may not apply to you. THIS WARRANTY IS EXPRESSLY IN LIEU OF ALL OTHER WARRANTIES, EXPRESS OR IMPLIED, INCLUDING THE WARRANTIES OF MERCHANTABILITY AND FITNESS.

To take advantage of this warranty, the product or part must be returned to us with transportation charges prepaid. Proof of purchase date and an explanation of the complaint must accompany the merchandise. If our inspection verifies the defect, we will either repair or replace the product at our election or we may elect to refund the purchase price if we cannot readily and quickly provide you with a replacement. We will return repaired products at our expense, but if we determine there is no defect, or that the defect resulted from causes not within the scope of our warranty, then you must bear the cost of returning the product.

This warranty gives you specific legal rights and you may also have other rights which vary from state to state.

CENTRALPNEUMATIC®

3491 Mission Oaks Blvd. • PO Box 6009 • Camarillo, CA 93011 • 1-888-866-5797

www.harborfreight.com

Owner's Manual & Safety Instructions

Save This Manual Keep this manual for the safety warnings and precautions, assembly, operating, inspection, maintenance and cleaning procedures. Write the product's serial number in the back of the manual near the assembly diagram (or month and year of purchase if product has no number). Keep this manual and the receipt in a safe and dry place for future reference.

REV 17a

PREDATOR[®] E N G I N E S

212cc Horizontal Engine

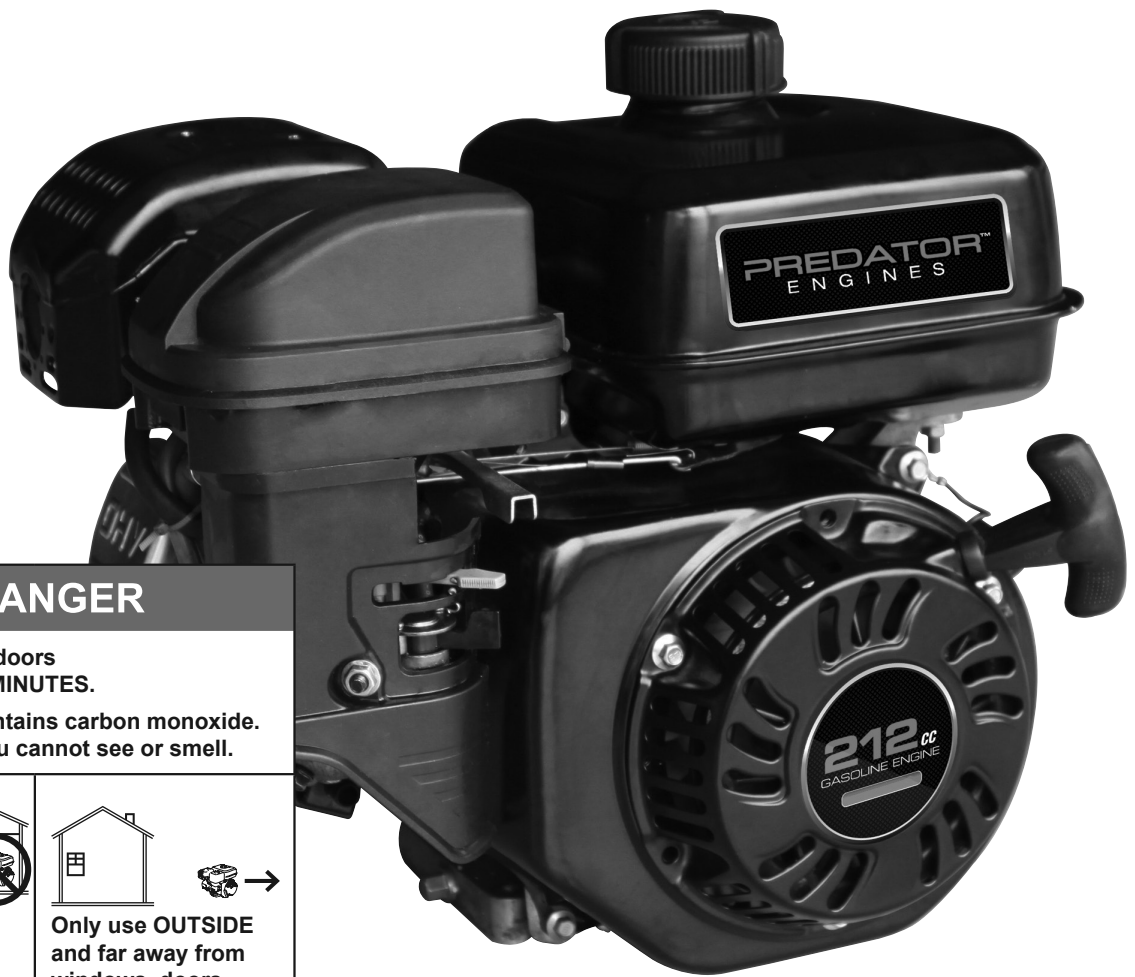

⚠ DANGER

Using an engine indoors
CAN KILL YOU IN MINUTES.

Engine exhaust contains carbon monoxide.
This is a poison you cannot see or smell.



NEVER use inside
a home or garage,
EVEN IF doors and
windows are open.



Only use **OUTSIDE**
and far away from
windows, doors,
and vents.

Visit our website at: <http://www.harborfreight.com>
Email our technical support at: predator@harborfreight.com

Engine for
62404

When unpacking, make sure that the product is intact and undamaged. If any parts are missing or broken, please call 1-888-866-5797 as soon as possible.

⚠ WARNING

**Read this material before using this product.
Failure to do so can result in serious injury.
SAVE THIS MANUAL.**

Copyright © 2014 by Harbor Freight Tools®. All rights reserved.
No portion of this manual or any artwork contained herein may be reproduced in any shape or form without the express written consent of Harbor Freight Tools. Diagrams within this manual may not be drawn proportionally. Due to continuing improvements, actual product may differ slightly from the product described herein. Tools required for assembly and service may not be included.

Table of Contents

Specifications	2	Maintenance	12
Safety	3	Troubleshooting	16
Setup	6	Warranties	18
Operation	8	Parts Lists and Diagrams	20

Specifications

Displacement		212cc
Engine Type		Horizontal Single Cylinder 4 stroke OHV
Cooling System		Forced air cooled
Fuel	Type	87+ octane unleaded gasoline
	Capacity	0.9 Gallon (3.6 Liter)
Engine Oil	Type SAE	10W-30 above 32° F 5W-30 at 32° F or below
	Capacity	0.5 qt
Run Time @ 50% Load with full tank		3 hr.
Sound Level at 22 feet		91 dB
Bore x Stroke		70 mm x 55 mm
Compression Ratio		8.5:1
Rotation viewed from PTO (power takeoff - the output shaft)		Counterclockwise
Shaft	Shaft	3/4" x 2.43"
	Keyway	3/16" (4.76 mm)
	End Tapped	5/16" - 24 UNF
Spark Plug	Type	NGK® BP-6ES NHSP® / Torch® F6TC
	Gap	0.0275" - 0.0314"
Valve Clearance	Intake	0.0039" - 0.0059"
	Exhaust	0.0059" - 0.0078"
Speed	Idle	2260 ± 50 RPM

The emissions control system for this Engine is warranted for standards set by the U.S. Environmental Protection Agency and by the California Air Resources Board (also known as CARB). For warranty information, refer to the last pages of this manual.



PREDATOR[®]



E N G I N E S

WARNING SYMBOLS AND DEFINITIONS

	This is the safety alert symbol. It is used to alert you to potential personal injury hazards. Obey all safety messages that follow this symbol to avoid possible injury or death.
⚠ DANGER	Indicates a hazardous situation which, if not avoided, will result in death or serious injury.
⚠ WARNING	Indicates a hazardous situation which, if not avoided, could result in death or serious injury.
⚠ CAUTION	Indicates a hazardous situation which, if not avoided, could result in minor or moderate injury.
NOTICE CAUTION	Addresses practices not related to personal injury.

Symbol Definitions

Symbol	Property or Statement
RPM	Revolutions Per Minute
HP	Horsepower
	WARNING marking concerning Risk of Eye Injury. Wear ANSI-approved safety goggles with side shields.
	Read the manual before set-up and/or use.
	WARNING marking concerning Risk of Hearing Loss. Wear hearing protection.

Symbol	Property or Statement
	WARNING marking concerning Risk of Respiratory Injury. Operate engine OUTSIDE and far away from windows, doors, and vents.
	WARNING marking concerning Risk of Fire while handling fuel. Do not smoke while handling fuel.
	WARNING marking concerning Risk of Fire. Do not refuel while operating. Keep flammable objects away from engine.

Safety Warnings



WARNING! Read all instructions.

Failure to follow all instructions listed below may result in fire, serious injury and/or DEATH.

The warnings and precautions discussed in this manual cannot cover all possible conditions and situations that may occur. It must be understood by the operator that common sense and caution are factors which cannot be built into this product, but must be supplied by the operator.

SAVE THESE INSTRUCTIONS

Set up Precautions

1. Gasoline fuel and fumes are flammable, and potentially explosive. Use proper fuel storage and handling procedures. Do not store fuel or other flammable materials nearby.
2. Have multiple ABC class fire extinguishers nearby.
3. Operation of this equipment may create sparks that can start fires around dry vegetation. A spark arrestor may be required. The operator should contact local fire agencies for laws or regulations relating to fire prevention requirements.
4. Set up and use only on a flat, level, well-ventilated surface.
5. Wear ANSI-approved safety goggles, heavy-duty work gloves, and dust mask/respirator during set up.
6. Use only lubricants and fuel recommended in the Specifications chart of this manual.

Operating Precautions

1.  **CARBON MONOXIDE HAZARD**
Using an engine indoors CAN KILL YOU IN MINUTES.
Engine exhaust contains carbon monoxide. This is a poison you cannot see or smell.

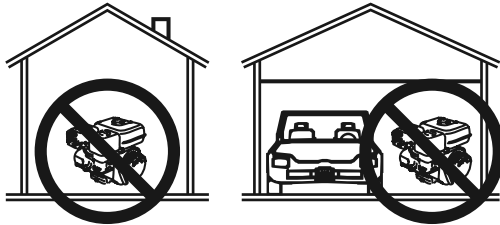

NEVER use inside a home or garage, EVEN IF doors and windows are open.

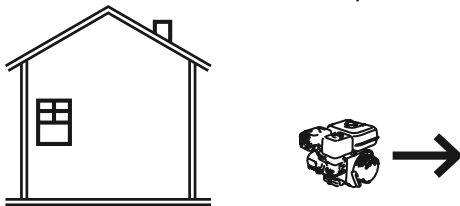

Only use OUTSIDE and far away from windows, doors, and vents.

2. Keep children away from the equipment, especially while it is operating.
3. Keep all spectators at least six feet from the Engine during operation.
4. Fire Hazard! Do not fill gas tank while engine is running. Do not operate if gasoline has been spilled. Clean spilled gasoline before starting engine. Do not operate near pilot light or open flame.
5. Do not touch engine during use. Let engine cool down after use.
6. Never store fuel or other flammable materials near the engine.
7. Only use a suitable means of transport and lifting devices with sufficient weight bearing capacity when transporting the Engine.
8. Secure the Engine on transport vehicles to prevent the tool from rolling, slipping, and tilting.
9. Industrial applications must follow OSHA requirements.

10. Do not leave the equipment unattended when it is running. Turn off the equipment (and remove safety keys, if available) before leaving the work area.
11. Engine can produce high noise levels. Prolonged exposure to noise levels above 85 dBA is hazardous to hearing. Always wear ear protection when operating or working around the gas engine while it is operating.
12. Wear ANSI-approved safety glasses, hearing protection, and NIOSH-approved dust mask/respirator under a full face shield along with steel-toed work boots during use.
13. People with pacemakers should consult their physician(s) before use. Electromagnetic fields in close proximity to a heart pacemaker could cause pacemaker interference or pacemaker failure. Caution is necessary when near the engine's magneto or recoil starter.
14. Use only accessories that are recommended by Harbor Freight Tools for your model. Accessories that may be suitable for one piece of equipment may become hazardous when used on another piece of equipment.
15. Do not operate in explosive atmospheres, such as in the presence of flammable liquids, gases, or dust. Gasoline-powered engines may ignite the dust or fumes.
16. Stay alert, watch what you are doing and use common sense when operating this piece of equipment. Do not use this piece of equipment while tired or under the influence of drugs, alcohol or medication.
17. Do not overreach. Keep proper footing and balance at all times. This enables better control of the equipment in unexpected situations.
18. Use this equipment with both hands only. Using equipment with only one hand can easily result in loss of control.
19. Dress properly. Do not wear loose clothing or jewelry. Keep hair, clothing and gloves away from moving parts. Loose clothes, jewelry or long hair can be caught in moving parts.

Operating Precautions (cont.)

20. Parts, especially exhaust system components, get very hot during use. Stay clear of hot parts.
21. Do not cover the engine or equipment during operation.
22. Keep the equipment, engine, and surrounding area clean at all times.
23. Do not smoke, or allow sparks, flames, or other sources of ignition around the equipment, especially when refuelling.
24. Use the equipment, accessories, etc., in accordance with these instructions and in the manner intended for the particular type of equipment, taking into account the working conditions and the work to be performed. Use of the equipment for operations different from those intended could result in a hazardous situation.
25. Do not operate the equipment with known leaks in the engine's fuel system.
26. **WARNING:** This product contains or, when used, produces a chemical known to the State of California to cause cancer and birth defects or other reproductive harm. (California Health & Safety Code § 25249.5, *et seq.*)
27. When spills of fuel or oil occur, they must be cleaned up immediately. Dispose of fluids and cleaning materials as per any local, state, or federal codes and regulations. Store oil rags in a bottom-ventilated, covered, metal container.
28. Keep hands and feet away from moving parts. Do not reach over or across equipment while operating.
29. Before use, check for misalignment or binding of moving parts, breakage of parts, and any other condition that may affect the equipment's operation. **If damaged, have the equipment serviced before using.** Many accidents are caused by poorly maintained equipment.
30. Use the correct equipment for the application. Do not modify the equipment and do not use the equipment for a purpose for which it is not intended.

Service Precautions

1. **Before service, maintenance, or cleaning:**
 - a. **Turn the engine switch to its "OFF" position.**
 - b. **Allow the engine to completely cool.**
 - c. **Then, remove the spark plug cap from the spark plug.**
 2. Keep all safety guards in place and in proper working order. Safety guards include muffler, air cleaner, mechanical guards, and heat shields, among other guards.
 3. **Do not alter or adjust any part of the equipment or its engine that is sealed by the manufacturer or distributor. Only a qualified service technician may adjust parts that may increase or decrease governed engine speed.**
 4. Wear ANSI-approved safety goggles, heavy-duty work gloves, and dust mask/respirator during service.
 5. Maintain labels and nameplates on the equipment. These carry important information. If unreadable or missing, contact Harbor Freight Tools for a replacement.
 6. Have the equipment serviced by a qualified repair person using only identical replacement parts. This will ensure that the safety of the equipment is maintained. Do not attempt any service or maintenance procedures not explained in this manual or any procedures that you are uncertain about your ability to perform safely or correctly.
 7. Store equipment out of the reach of children.
 8. Follow scheduled engine and equipment maintenance.
- Refueling:**
1. Do not refill the fuel tank while the engine is running or hot.
 2. Do not smoke, or allow sparks, flames, or other sources of ignition around the equipment, especially when refuelling.
 3. Do not fill fuel tank to the top. Leave a little room for the fuel to expand as needed.
 4. Refuel in a well-ventilated area only.
 5. Wipe up any spilled fuel and allow excess to evaporate before starting engine. **To prevent FIRE, do not start the engine while the smell of fuel hangs in the air.**



SAVE THESE INSTRUCTIONS.

Set Up



Read the **ENTIRE IMPORTANT SAFETY INFORMATION** section at the beginning of this manual including all text under subheadings therein before set up or use of this product.

WARNING

TO PREVENT SERIOUS INJURY:

Operate only with proper spark arrestor installed.

Operation of this equipment may create sparks that can start fires around dry vegetation.

A spark arrestor may be required.

The operator should contact local fire agencies for laws or regulations relating to fire prevention requirements.

At high altitudes, the engine's carburetor, governor (if so equipped), and any other parts that control the fuel-air ratio will need to be adjusted by a qualified mechanic to allow efficient high-altitude use and to prevent damage to the engine and any other devices used with this product.

The emission control system for this Engine is warranted for standards set by the U.S. Environmental Protection Agency and by the California Air Resources Board (also known as CARB). For warranty information, refer to the last pages of this manual.

WARNING! DO NOT INSTALL THIS ENGINE ON A VEHICLE.

Engine Controls

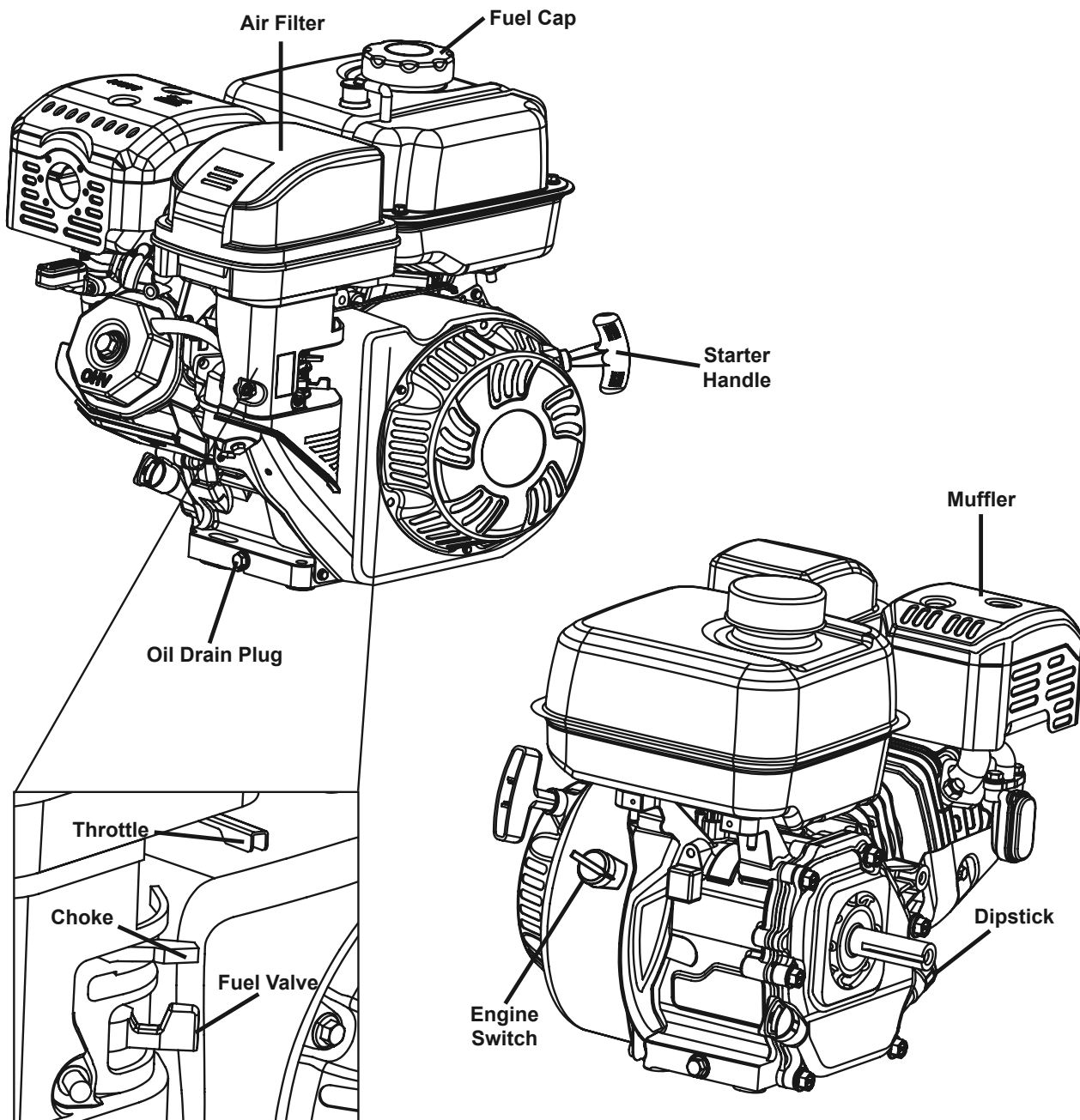

High Altitude Operation Above 3000 feet

The fuel system on this engine may be influenced by operation at higher altitudes. Proper operation can be ensured by installing an altitude kit at altitudes higher than 3000 ft. above sea level. At elevations above 8000 ft, the engine may experience decreased performance, even with the proper main jet. Operating this engine without the proper altitude kit installed may increase the engine's emissions and decrease fuel economy and performance. The kit should be installed by a qualified mechanic.

⚠️WARNING! TO PREVENT SERIOUS INJURY FROM FIRE:

Follow kit procedures in a well-ventilated area away from ignition sources. If the engine is hot from use, shut the engine off and wait for it to cool before proceeding. Do not smoke.

NOTICE Warranty void if necessary adjustments are not made for high altitude use.

High Altitude Kit Installation Instructions

1. Turn off the engine.
2. Close the fuel valve.
3. Place a bowl under the fuel cup to catch any spilled fuel.
4. Unthread the bolt holding the fuel cup.

CAUTION! Carburetor bowl may have gas in it which will leak upon removing the bolt.

5. Remove the bolt, bolt seal, fuel cup, fuel cup seal and main jet from the body of the carburetor assembly. A carburetor screwdriver (not included) is needed to remove and install the Main Jet.

Note: The mixing tube is held in place by the main jet and might fall out when it is removed. If it falls out, replace it in the same orientation before replacing the main jet.

6. Replace the main jet with the replacement jet needed for your altitude range (part 1 or 2).

Note: The Fuel cup seal and bolt seal may be damaged during removal and should be replaced with the new ones from the kit.

7. Replace the Fuel Cup Seal (4), fuel cup, Bolt Seal (3) and bolt. Tighten in place.

NOTICE: Do not cross thread Bolt when tightening. Finger tighten first and then use a wrench to make sure the Bolt is properly threaded.

8. Wipe up any spilled fuel and allow excess to evaporate before starting engine. To prevent FIRE, do not start the engine while the smell of fuel hangs in the air.

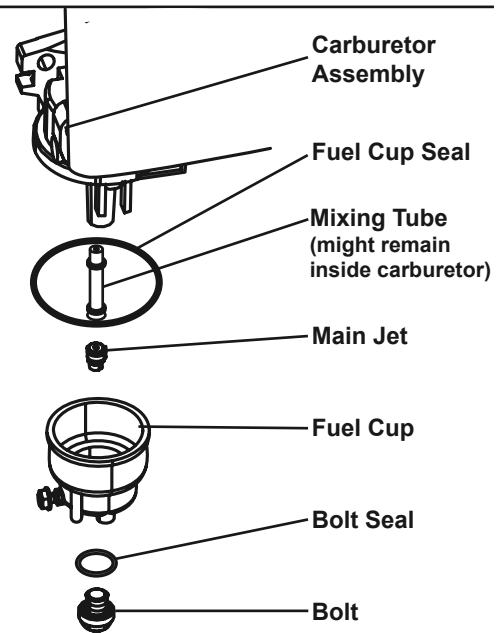

Altitude Kit Parts List

Part	Description	Qty
1	Main Jet 3000-6000 ft.	1
2	Main Jet 6000-8000 ft.	1
3	Bolt Seal	1
4	Fuel Cup Seal	1

Operation



Read the **ENTIRE IMPORTANT SAFETY INFORMATION** section at the beginning of this manual including all text under subheadings therein before set up or use of this product.

SAFETY

Pre-Start Checks

Inspect engine and equipment looking for damaged, loose, and missing parts before set up and starting. If any problems are found, do not use equipment until fixed properly.

Checking and Filling Engine Oil

NOTICE: Your Warranty is VOID if the engine's crankcase is not properly filled with oil before each use. Before each use, check the oil level. Engine will not start with low or no engine oil.

1. Make sure the engine is stopped and is level.
2. Close the Fuel Valve.
3. Clean the top of the Dipstick and the area around it. Remove the Dipstick by turning it counterclockwise, and wipe it off with a clean, lint free rag.

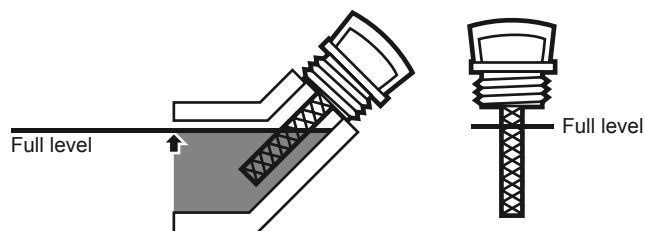

4. Reinsert the Dipstick without threading it in and remove it to check the oil level. The oil level should be up to the full level as shown above.
5. If the oil level is at or below the low mark add the appropriate type of oil until the oil level is at the proper level. SAE 10W-30 oil is recommended for general use. (The SAE Viscosity Grade chart on page 13 in the Maintenance section shows other viscosities to use in different average temperatures.)
6. Thread the dipstick back in clockwise.

NOTICE: Do not run the engine with too little oil. Engine will shut off if engine oil level is too low.

Checking and Filling Fuel



WARNING! TO PREVENT SERIOUS INJURY FROM FIRE:

Fill the fuel tank in a well-ventilated area away from ignition sources. If the engine is hot from use, shut the engine off and wait for it to cool before adding fuel. Do not smoke.

1. Clean the Fuel Cap and the area around it.
2. Unscrew and remove the Fuel Cap.
3. Remove the Strainer and remove any dirt and debris. Then replace the Strainer.

Note: Do not use gasoline containing more than 10% ethanol (E10). Do not use E85 ethanol. Add fuel stabilizer to the gasoline or the Warranty is VOID.

Note: Do not use gasoline that has been stored in a metal fuel container or a dirty fuel container. It can cause particles to enter the carburetor, affecting engine performance and/or causing damage.

4. If needed, fill the Fuel Tank to about 1 inch under the fill neck of the Fuel Tank with 90 octane or higher unleaded gasoline that has been treated with a fuel stabilizer additive. Follow fuel stabilizer manufacturer's recommendations for use.
5. Then replace the Fuel Cap.
6. Wipe up any spilled fuel and allow excess to evaporate before starting engine. To prevent FIRE, do not start the engine while the smell of fuel hangs in the air.

SETUP

OPERATION

MAINTENANCE

Starting the Engine

Before Starting the Engine



Before starting the engine:

- Follow the Set Up Instructions in the equipment manual to prepare the equipment.
- Inspect the equipment and engine.
- Fill the engine with the proper amount and type of both stabilizer-treated unleaded gasoline and oil.
- Read the Equipment Operation section in the equipment manual.

Manual Start

1. Close the Drain Valves by turning the levers up so that they are perpendicular to the valve.

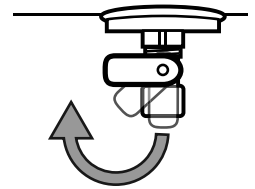
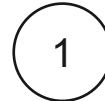

2. Open the Pilot Valve by rotating it to a vertical position.

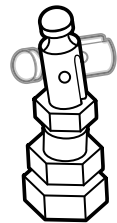

3. Open the Fuel Valve.

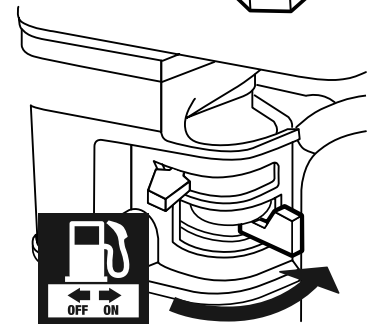

4. To start a cold engine, move the Choke to the START position.
To restart a warm engine, leave the Choke in the RUN position.

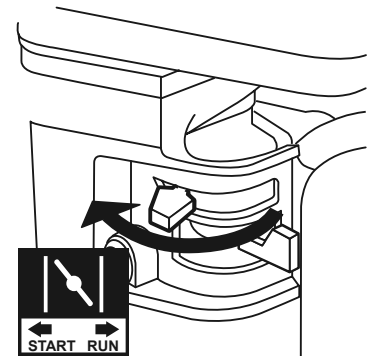

5. Slide the Throttle or Speed Control Lever to 1/3 away from the SLOW position (the "turtle").



Note: Some tools have a Speed Control Lever located elsewhere on the tool which functions the same as the Throttle. Use the Speed Control Lever in place of the Throttle when the tool is so equipped.

Manual Start (cont'd)

SAFETY

6. Turn the Engine Switch on.

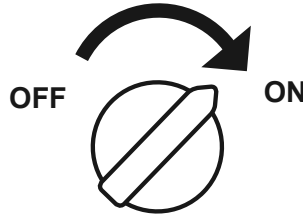

6

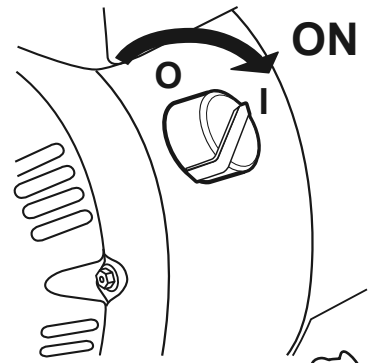

Note: If engine does not start, check engine oil level. Engine will not start with low or no engine oil.

7. Grip the Starter Handle of the Engine loosely and pull it slowly several times to allow the gasoline to flow into the Engine's carburetor. Then pull the Starter Handle gently until resistance is felt. Allow Cable to retract fully and then pull it quickly. Repeat until the engine starts.

7

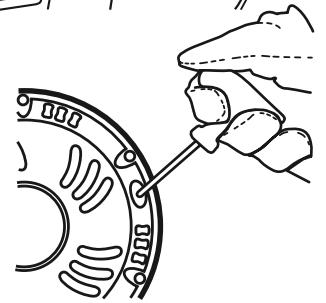

Note: Do not let the Starter Handle snap back against the engine. Hold it as it recoils so it doesn't hit the engine.

SETUP

8. Allow the Engine to run for several seconds. Then, if the Choke Lever is in the START position, move the Choke Lever very slowly to its RUN position.

8

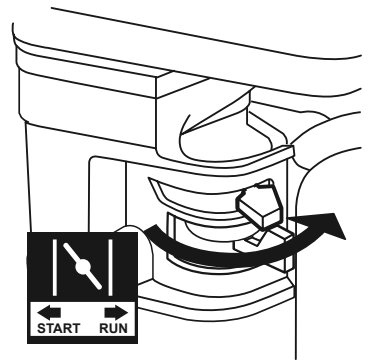

Note: Moving the Choke Lever too fast could stall the engine.

9. Close the Pilot Valve by rotating it to a horizontal position.

9

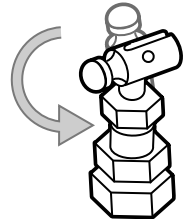

10. When the Gas Engine is started and running, the compressor Pump starts compressing air into the Air Tank. Open the in-line Shutoff Valve and adjust the Pressure Regulator (sold separately) so that the air output is enough to properly power the tool, but the output will not exceed the tool's maximum air pressure at any time. Turn the knob clockwise to increase the pressure and counterclockwise to decrease pressure. Adjust the pressure gradually, while checking the air output gauge to set the pressure.

10

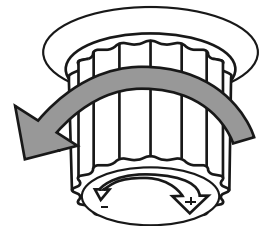

OPERATION

MAINTENANCE

Manual Start (cont'd)

IMPORTANT: Allow the engine to run at no load for five minutes with no load after each start-up so that the engine can stabilize.

11. Adjust the Throttle as needed.

12. **Break-in Period:**

- a. Breaking-in the engine will help to ensure proper equipment and engine operation.
- b. The operational break-in period will last about 3 hours of use. During this period:
 - Do not apply a heavy load to the equipment.
 - Do not operate the engine at its maximum speed.
- c. The maintenance break-in period will last about 20 hours of use. After this period:
 - Change the engine oil.

Under normal operating conditions subsequent maintenance follows the schedule explained in the MAINTENANCE AND SERVICING section.

Stopping the Engine

1. To stop the engine in an emergency, turn the Engine Switch off.
2. Under normal conditions, use the following procedure:
 - a. Slide the Throttle or Speed Control Lever to SLOW (the “turtle”).
 - b. Turn the Engine Switch off.
 - c. Close the Fuel Valve.

WARNING! The fuel valve must be closed before moving the engine to prevent fuel leakage and fire.

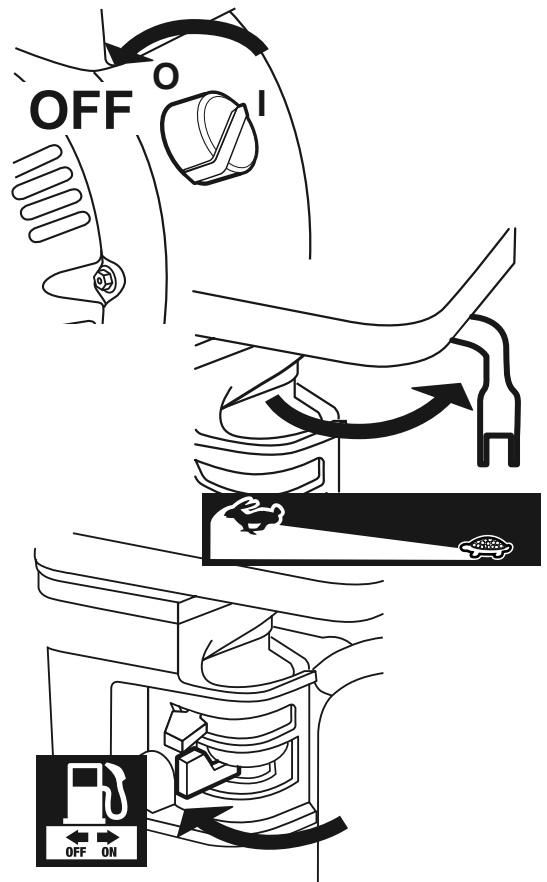

NOTICE

See “Long-Term Storage” on page 15 for complete storage instructions.

⚠ WARNING

TO PREVENT SERIOUS INJURY FROM ACCIDENTAL STARTING:

Turn the Power Switch of the equipment to its “OFF” position, wait for the engine to cool, and disconnect the spark plug cap before performing any inspection, maintenance, or cleaning procedures.

TO PREVENT SERIOUS INJURY FROM EQUIPMENT FAILURE:

Do not use damaged equipment. If abnormal noise, vibration, or excess smoking occurs, have the problem corrected before further use.

Follow all service instructions in this manual. The engine may fail critically if not serviced properly.



Many maintenance procedures, including any not detailed in this manual, will need to be performed by a qualified technician for safety. If you have any doubts about your ability to safely service the equipment or engine, have a qualified technician service the equipment instead.

Cleaning, Maintenance, and Lubrication Schedule

Note: This maintenance schedule is intended solely as a general guide. If performance decreases or if equipment operates unusually, check systems immediately. The maintenance needs of each piece of equipment will differ depending on factors such as duty cycle, temperature, air quality, fuel quality, and other factors.

Note: The following procedures are in addition to the regular checks and maintenance explained as part of the regular operation of the engine and equipment.

Procedure	Before Each Use	Monthly or every 20 hr. of use	Every 3 mo. or 50 hr. of use	Every 6 mo. or 100 hr. of use	Yearly or every 300 hr. of use	Every 2 Years
Brush off outside of engine	✓	✓	✓	✓	✓	✓
Check engine oil level	✓	✓	✓	✓	✓	✓
Check air cleaner	✓		✓	✓	✓	✓
Check deposit cup	✓			✓	✓	✓
Change engine oil		✓		✓	✓	✓
Clean/replace air cleaner			✓*	✓	✓	✓
Check and clean spark plug				✓	✓	✓
1. Check/adjust idle speed 2. Check/adjust valve clearance 3. Clean fuel tank, strainer and carburetor 4. Clean carbon build-up from combustion chamber					✓**	✓**
Replace fuel line if necessary						✓**

*Service more frequently when used in dusty areas.

**These items should be serviced by a qualified technician.

PREDATOR
E N G I N E S

Checking and Filling Fuel



⚠️ WARNING! TO PREVENT SERIOUS INJURY FROM FIRE:

Fill the fuel tank in a well-ventilated area away from ignition sources. If the engine is hot from use, shut the engine off and wait for it to cool before adding fuel. Do not smoke.

1. Clean the Fuel Cap and the area around it.
2. Unscrew and remove the Fuel Cap.
3. Remove the Strainer and remove any dirt and debris. Then replace the Strainer.

Note: Do not use gasoline containing more than 10% ethanol (E10). Do not use E85 ethanol. Add fuel stabilizer to the gasoline or the Warranty is VOID.

Note: Do not use gasoline that has been stored in a metal fuel container or a dirty fuel container. It can cause particles to enter the carburetor, affecting engine performance and/or causing damage.

4. If needed, fill the Fuel Tank to about 1 inch under the fill neck of the Fuel Tank with 90 octane or higher unleaded gasoline that has been treated with a fuel stabilizer additive. Follow fuel stabilizer manufacturer's recommendations for use.
5. Then replace the Fuel Cap.
6. Wipe up any spilled fuel and allow excess to evaporate before starting engine. To prevent FIRE, do not start the engine while the smell of fuel hangs in the air.

Engine Oil Change

⚠️ CAUTION! Oil is very hot during operation and can cause burns. Wait for engine to cool before changing oil.

1. Make sure the engine is stopped and is level.
2. Close the Fuel Valve.
3. Place a drain pan (not included) underneath the crankcase's drain plug.
4. Remove the drain plug and, if possible, tilt the crankcase slightly to help drain the oil out. Recycle used oil.
5. Replace the drain plug and tighten it.
6. Clean the top of the Dipstick and the area around it. Remove the Dipstick by turning it counterclockwise, and wipe it off with a clean, lint free rag.

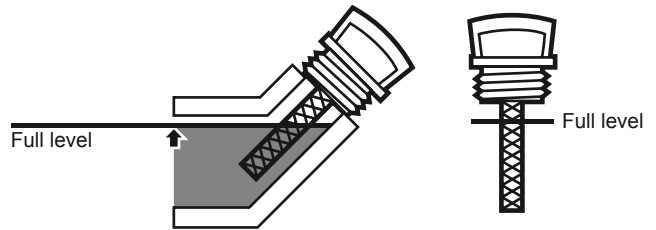

7. Add the appropriate type of oil until the oil level is at the full level. SAE 10W-30 oil is recommended for general use. The SAE Viscosity Grade chart shows other viscosities to use in different average temperatures.

SAE Viscosity Grades

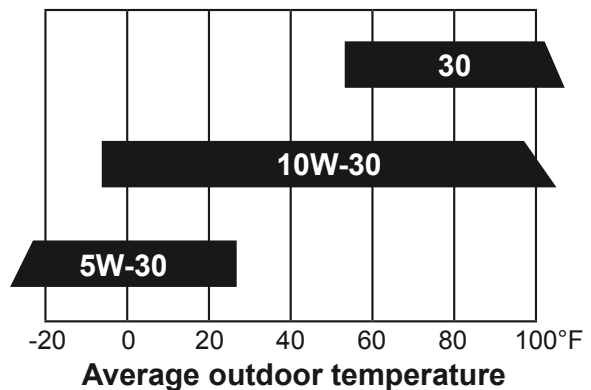

8. Thread the dipstick back in clockwise.

NOTICE: Do not run the engine with too little oil. Engine will not start with low or no engine oil.

Air Filter Element Maintenance

1. Remove the air filter cover and the air filter elements and check for dirt. Clean or replace as described below.
2. **Cleaning:**
 - For “paper” filter elements:
To prevent injury from dust and debris, wear ANSI-approved safety goggles, NIOSH-approved dust mask/respirator, and heavy-duty work gloves. In a well-ventilated area away from bystanders, use pressurized air to blow dust out of the air filter. If this does not get the filter clean, replace it.
 - For foam filter elements:
Wash the element in warm water and mild detergent several times. Rinse. Squeeze out excess water and allow it to dry completely. Soak the filter in lightweight oil briefly, then squeeze out the excess oil.
3. Install the new filter or the cleaned filter. Secure the Air Cleaner Cover before use.

Spark Plug Maintenance

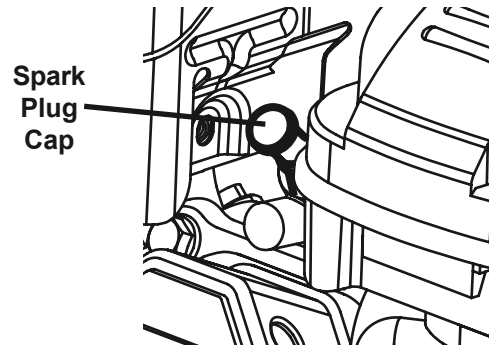

1. Disconnect spark plug cap from end of plug. Clean out debris from around spark plug.
2. Using a spark plug wrench, remove the spark plug.
3. Inspect the spark plug:
If the electrode is oily, clean it using a clean, dry rag. If the electrode has deposits on it, polish it using emery paper. If the white insulator is cracked or chipped, the spark plug needs to be replaced.

Recommended Spark Plugs	
NGK®	BP-6ES
NHSP®/TORCH®	F6TC

NOTICE: Using an incorrect spark plug may damage the engine.

4. When installing a new spark plug, adjust the plug's gap to the specification on the Technical Specifications chart. Do not pry against the electrode, the spark plug can be damaged.
5. Install the new spark plug or the cleaned spark plug into the engine. Gasket-style: Finger-tighten until the gasket contacts the cylinder head, then tighten about 1/2-2/3 turn more.
Non-gasket-style: Finger-tighten until the plug contacts the head, then tighten about 1/16 turn more.

NOTICE: Tighten the spark plug properly. If loose, the spark plug will cause the engine to overheat.

If overtightened, the threads in the engine block will be damaged.

6. Apply dielectric spark plug boot protector (not included) to the end of the spark plug and reattach the wire securely.

Long-Term Storage

When the equipment is to remain idle for longer than 20 days, prepare the engine for storage as follows:

1. **CLEANING:**

Wait for engine to cool, then clean engine with dry cloth. **NOTICE: Do not clean using water.** The water will gradually enter the engine and cause rust damage. Apply a thin coat of rust preventive oil to all metal parts.

2. **FUEL:**

To protect the fuel tank during storage, fill the tank with gasoline that has been treated with a fuel stabilizer additive. Follow fuel stabilizer manufacturer's recommendations for use. Refer to "Checking and Filling Fuel" on page 8.



⚠️ WARNING! TO PREVENT SERIOUS INJURY FROM FIRE:

Fill tank in a well-ventilated area away from ignition sources. If the engine is hot from use, shut the engine off and wait for it to cool before adding fuel. Do not smoke.

3. **LUBRICATION:**

- Change engine oil.
- Clean out area around spark plug.
Remove spark plug and pour one tablespoon of engine oil into cylinder through spark plug hole.

- Replace spark plug, but leave spark plug cap disconnected.
- Pull Starter Handle to distribute oil in cylinder. Stop after one or two revolutions when you feel the piston start the compression stroke (when you start to feel resistance).

4. **BATTERY:**

Disconnect battery cables (if equipped). Recharge batteries monthly while in storage.

5. **STORAGE AREA:**

Cover and store in a dry, level, well-ventilated area out of reach of children. Storage area should also be away from ignition sources, such as water heaters, clothes dryers, and furnaces.

NOTICE: During extended storage periods the Engine must be started every 3 months and allowed to run for 15–20 minutes or the Warranty is VOID.

6. **STARTING ENGINE DURING/AFTER STORAGE:**

Before starting the Engine during or after storage, keep in mind that untreated gasoline will deteriorate quickly. Drain the fuel tank and change to fresh fuel if untreated gasoline has been sitting for a month, if treated gasoline has been sitting beyond the fuel stabilizer's recommended time period, or if the Engine does not start. For Engine starting instructions refer to "Starting the Engine" on page 9.

Troubleshooting

SAFETY

SETUP

OPERATION

MAINTENANCE

Problem	Possible Causes	Probable Solutions
Engine will not start	FUEL RELATED: <ol style="list-style-type: none"> No fuel in tank or fuel valve closed. Choke not in START position, cold engine. Gasoline with more than 10% ethanol used. (E15, E20, E85, etc.) Low quality or deteriorated, old gasoline. Carburetor not primed. Dirty fuel passageways. Carburetor needle stuck. Fuel can be smelled in the air. Too much fuel in chamber. This can be caused by the carburetor needle sticking. Clogged Fuel Filter. 	FUEL RELATED: <ol style="list-style-type: none"> Fill fuel tank with fresh 90+ octane stabilizer-treated unleaded gasoline and open fuel valve. Do not use gasoline with more than 10% ethanol (E15, E20, E85, etc.). Move Choke to START position. Clean out ethanol rich gasoline from fuel system. Replace components damaged by ethanol. Use fresh 90+ octane stabilizer-treated unleaded gasoline only. Do not use gasoline with more than 10% ethanol (E15, E20, E85, etc.). Use fresh 87+ octane stabilizer-treated unleaded gasoline. Do not use gasoline with more than 10% ethanol (E15, E20, E85, etc.). Pull on Starter Handle to prime. Clean out passageways using fuel additive. Heavy deposits may require further cleaning. Gently tap side of carburetor float chamber with screwdriver handle. Turn Choke to RUN position. Remove spark plug and pull the start handle several times to air out the chamber. Reinstall spark plug and set Choke to START position. Replace Fuel Filter.
	IGNITION (SPARK) RELATED: <ol style="list-style-type: none"> Spark plug cap not connected securely. Spark plug electrode wet or dirty. Incorrect spark plug gap. Spark plug cap broken. Incorrect spark timing or faulty ignition system. 	IGNITION (SPARK) RELATED: <ol style="list-style-type: none"> Connect spark plug cap properly. Clean spark plug. Correct spark plug gap. Replace spark plug cap. Have qualified technician diagnose/repair ignition system.
	COMPRESSION RELATED: <ol style="list-style-type: none"> Cylinder not lubricated. Problem after long storage periods. Loose or broken spark plug. (Hissing noise will occur when trying to start.) Loose cylinder head or damaged head gasket. (Hissing noise will occur when trying to start.) Engine valves or tappets mis-adjusted or stuck. 	COMPRESSION RELATED: <ol style="list-style-type: none"> Pour tablespoon of oil into spark plug hole. Crank engine a few times and try to start again. Tighten spark plug. If that does not work, replace spark plug. If problem persists, may have head gasket problem, see #3. Tighten head. If that does not remedy problem, replace head gasket. Have qualified technician adjust/repair valves and tappets.
	ENGINE OIL RELATED: <ol style="list-style-type: none"> Low engine oil. Engine mounted on slope, triggering low oil shutdown. 	ENGINE OIL RELATED: <ol style="list-style-type: none"> Fill engine oil to proper level. Check engine oil before EVERY use. Operate engine on level surface. Check engine oil level.



Follow all safety precautions whenever diagnosing or servicing the equipment or engine.

Problem	Possible Causes	Probable Solutions
Engine misfires	<ol style="list-style-type: none"> 1. Spark plug cap loose. 2. Incorrect spark plug gap or damaged spark plug. 3. Defective spark plug cap. 4. Old or low quality gasoline. 5. Incorrect compression. 	<ol style="list-style-type: none"> 1. Check cap and wire connections. 2. Re-gap or replace spark plug. 3. Replace spark plug cap. 4. Use only fresh 90+ octane stabilizer-treated unleaded gasoline. Do not use gasoline with more than 10% ethanol (E15, E20, E85, etc.). 5. Diagnose and repair compression. (Use Engine will not start: COMPRESSION RELATED section.)
Engine stops suddenly	<ol style="list-style-type: none"> 1. Fuel tank empty or full of impure or low quality gasoline. 2. Low oil shutdown. 3. Defective fuel tank cap creating vacuum, preventing proper fuel flow. 4. Faulty magneto. 5. Disconnected or improperly connected spark plug cap. 	<ol style="list-style-type: none"> 1. Fill fuel tank with fresh 90+ octane stabilizer-treated unleaded gasoline. Do not use gasoline with more than 10% ethanol (E15, E20, E85, etc.). 2. Fill engine oil to proper level. Check engine oil before EVERY use. 3. Test/replace fuel tank cap. 4. Have qualified technician service magneto. 5. Secure spark plug cap.
Engine stops when under heavy load	<ol style="list-style-type: none"> 1. Dirty air filter 2. Engine running cold. 	<ol style="list-style-type: none"> 1. Clean element. 2. Allow engine to warm up prior to operating equipment.
Engine knocks	<ol style="list-style-type: none"> 1. Old or low quality gasoline. 2. Engine overloaded. 3. Incorrect spark timing, deposit buildup, worn engine, or other mechanical problems. 	<ol style="list-style-type: none"> 1. Fill fuel tank with fresh 90+ octane stabilizer-treated unleaded gasoline. Do not use gasoline with more than 10% ethanol (E15, E20, E85, etc.). 2. Do not exceed equipment's load rating. 3. Have qualified technician diagnose and service engine.
Engine backfires After sudden impact, engine will run, but equipment will not operate	<ol style="list-style-type: none"> 1. Impure or low quality gasoline. 2. Engine too cold. 3. Intake valve stuck or overheated engine. 4. Incorrect timing. Shaft key or other shear pin broken by impact to disconnect engine and limit damage.	<ol style="list-style-type: none"> 1. Fill fuel tank with fresh 90+ octane stabilizer-treated unleaded gasoline. Do not use gasoline with more than 10% ethanol (E15, E20, E85, etc.). 2. Use cold weather fuel and oil additives to prevent backfiring. 3. Have qualified technician diagnose and service engine. 4. Check engine timing. Have qualified technician check and replace broken shaft key or other shear pins.



Follow all safety precautions whenever diagnosing or servicing the equipment or engine.

Limited 90 Day Warranty (Retail)

Harbor Freight Tools Co. makes every effort to assure that its products meet high quality and durability standards, and warrants to the original purchaser that this product is free from defects in materials and workmanship for the period of 90 days from the date of purchase. This warranty does not apply to damage due directly or indirectly, to misuse, abuse, negligence or accidents, repairs or alterations outside our facilities, criminal activity, improper installation, normal wear and tear, or to lack of maintenance. We shall in no event be liable for death, injuries to persons or property, or for incidental, contingent, special or consequential damages arising from the use of our product. Some states do not allow the exclusion or limitation of incidental or consequential damages, so the above limitation of exclusion may not apply to you. THIS WARRANTY IS EXPRESSLY IN LIEU OF ALL OTHER WARRANTIES, EXPRESS OR IMPLIED, INCLUDING THE WARRANTIES OF MERCHANTABILITY AND FITNESS, EXCEPT FOR THE EMISSIONS CONTROL SYSTEM WARRANTY BELOW.

To take advantage of this warranty, the product or part must be returned to us with transportation charges prepaid. Proof of purchase date and an explanation of the complaint must accompany the merchandise. If our inspection verifies the defect, we will either repair or replace the product at our election or we may elect to refund the purchase price if we cannot readily and quickly provide you with a replacement. We will return repaired products at our expense, but if we determine there is no defect, or that the defect resulted from causes not within the scope of our warranty, then you must bear the cost of returning the product.

This warranty gives you specific legal rights and you may also have other rights which vary from state to state.

Emissions Control System Warranty

The California Air Resources Board and Harbor Freight Tools (HFT) are pleased to explain the emissions control system warranty on your 2017 Small Off-Road Engine. In California, new equipment that uses small off-road engines must be designed, built, and equipped to meet the State's stringent anti-smog standards. HFT must warrant that the emissions control system on your engine will be free from defects in material and workmanship for two (2) years, provided there has been no abuse, neglect, or improper maintenance of your engine. HFT also warrants that the emissions control system on your engine is designed, built, and equipped so that it conforms to the United States Environmental Protection Agency's (EPA) emissions requirements in effect at the time of manufacture.

Your emissions control system may include parts such as the carburetor or fuel-injection system, the ignition system, catalytic converter, fuel tanks, fuel lines, fuel caps, valves, canisters, vapor hoses, clamps, connectors, and other emissions-related assemblies.

Where a warrantable condition exists, HFT will repair or replace, at our option, your engine if at no cost to you, including diagnosis, parts and labor.

MANUFACTURER'S WARRANTY COVERAGE

This emissions control system is warranted for two years. If any emission-related part on your engine is defective, the part will be repaired or replaced by HFT.

OWNER'S WARRANTY RESPONSIBILITIES

As the engine owner, you are responsible for the performance of the required maintenance listed in your Owner's Manual.

As the engine owner, you should however be aware that HFT may deny you warranty coverage if your engine or a part has failed due to abuse (including failure to follow the fuel use instructions contained in this manual), neglect, improper maintenance, or unapproved modifications.

You are responsible for contacting HFT as soon as the problem exists in order to obtain warranty repair or replacement, by doing either of the following: (a) contact HFT product support at 1-888-866-5797 or predator@harborfreight.com; or (b) bring the to your nearest Harbor Freight Tools retail store. The nearest Harbor Freight Tools retail store can be found on the internet at <http://www.harborfreight.com>. The warranty repairs or replacement should be completed in a reasonable amount of time, not to exceed 30 days. If you have a question regarding your warranty coverage, you should contact HFT product support at 1-888-866-5797 or predator@harborfreight.com.

GENERAL EMISSIONS WARRANTY COVERAGE

- a) The warranty period begins on the date the engine or equipment is delivered to an ultimate purchaser. The warranty period is two years.
- b) HFT warrants to the initial owner and each subsequent owner that the engine is:
1. Designed, built, and equipped so as to conform with all applicable regulations adopted by the Air Resources Board; and
 2. Free from defects in materials and workmanship that causes the failure of a warranted part for a period of two years.
- c) The warranty on emissions-related parts is as follows:
1. Any warranted part that is not scheduled for replacement as required maintenance in the written instructions provided, is warranted for the warranty period stated above. If any such part fails during the period of warranty coverage, it will be repaired or replaced HFT. Any such part repaired or replaced under the warranty will be warranted for the remaining warranty period.
 2. Any warranted part that is scheduled only for regular inspection in the written instructions is warranted for the warranty period stated above. A statement in the written instructions to the effect of "repair or replace as necessary" does not reduce the period of warranty coverage. Any such part repaired or replaced under warranty will be warranted for the remaining warranty period.
 3. Any warranted part that is scheduled for replacement as required maintenance in the written instructions will be warranted for the period of time prior to the first scheduled replacement point for that part. If the part fails prior to the first scheduled replacement, the part will be repaired or replaced by HFT. Any such part repaired or replaced under warranty will be warranted for the remainder of the period prior to the first scheduled replacement point for the part.
 4. Repair or replacement of any warranted part under the warranty will be performed at no charge to the owner at a retail store or by HFT paying for shipping the product for repair.
 5. Notwithstanding the provisions herein, warranty services or repairs will be provided at all retail stores or by contacting HFT product support at 1-888-866-5797 or predator@harborfreight.com.
 6. The owner will not be charged for diagnostic labor that leads to the determination that a warranted part is in fact defective, provided that such diagnostic work is performed at a retail store.
 7. HFT is liable for damages to other engine components proximately caused by a failure under warranty of any warranted part.
 8. Throughout the emissions warranty period stated above, HFT will maintain a supply of warranted parts sufficient to meet the expected demand for such parts.
 9. Any replacement part may be used in the performance of any warranty maintenance or repairs and will be provided without charge to the owner. Such use will not reduce the warranty obligations of HFT.
 10. Add-on or modified parts that are not approved by HFT may not be used. The use of any non-exempted add-on or modified parts will be grounds for disallowing a warranty claim. HFT is not liable to warrant failures of warranted parts caused by the use of a non-exempted add-on or modified part.
- d) Emission Warranty Parts List.
- | | |
|--|---|
| 1. Fuel Metering System | 4. Catalyst System (if so equipped) |
| a. Carburetor and its internal parts (and/or pressure regulator or fuel injection system). | a. Exhaust pipe stud/exhaust manifold. |
| b. Fuel tank. | b. Thermal reactor. |
| c. Cold start enrichment system. | c. Catalytic converter (if so equipped). |
| d. Air/fuel ratio feedback and control system. | 5. Particulate Controls |
| 2. Air Induction System | a. Traps, filters, precipitators, and any other device used to capture particulate emissions. |
| a. Controlled hot air intake system. | 6. Miscellaneous Items Used in Above Systems |
| b. Intake manifold. | a. Vacuum, temperature and time sensitive valves and switches. |
| c. Air filter. | b. Hoses, belts, connectors, and assemblies. |
| 3. Ignition System | 7. Evaporative Emission Control System |
| a. Spark plugs. | a. Fuel tank. |
| b. Magneto ignition system. | b. Fuel caps, valves, canisters, filters, vapor hoses, clamps, connectors, belts, and assemblies. |
| c. Spark advance/retard system. | |

HFT provides with each product written instructions for the maintenance and use of the product by the owner.

Parts List

SAFETY

SETUP

OPERATION

MAINTENANCE

Part	Description	Qty
1	Gasket, Cylinder Head	1
2	Cover Subassembly, Cylinder Head	1
3	Gasket, Cylinder Head Cover	1
4	Tube, Breather	1
5	Bolt	4
6	Stud	2
7	Stud	2
8	Pin	2
9	Bolt, Cylinder Head	4
10	Plug, Spark	1
11	Head Subassembly, Cylinder	1
12	Crankcase Subassembly	1
13	Sensor, Engine Oil	1
14	Gear Asm, Governor	1
15	Arm, Governor	1
16	Bolt, Drain Plug	2
17	Washer, Flat	2
18	Bearing, Deep Groove Ball	2
19	Seal, Oil	1
20	Washer, Flat	1
21	Cotter	1
22	Bolt	2
23	Cover, Crankcase	1
24	Gasket, Crankcase	1
25	Pin	2
26	Dipstick Subassembly, Oil	1
27	Plug Subassembly, Engine Oil	1
28	Seal, Oil	1
29	Bolt	6
30	Crankshaft Asm.	1
31	Clip, Piston Pin	2
32	Piston	1
33	Pin, Piston	1
34	Rod, Connecting	1
35	Primary Ring	1
36	Secondary Ring	1
37	Ring Set, Oil	1
38	Camshaft Asm.	1
39	Valve, Exhaust	1
40	Valve, Intake	1
41	Seat, Valve Spring	2
42	Clamp, Valve Lock	4
43	Guide, Seal	2
44	Spring, Valve	2
45	Plate Subassembly, Lifter Stopper	1
46	Bolt, Rocker Shaft	2
47	Rocker, Valve	2

Part	Description	Qty
48	Nut, Valve Adjusting	2
49	Nut, Valve Lock	2
50	Tappet, Valve	2
51	Lifter, Valve	2
52	Starter Asm, Recoil	1
53	Bolt	1
54	Shroud	1
55	Bolt	4
56	Shroud, Cylinder Body	1
57	Bolt	2
58	Shield, Lower	1
59	Bolt	1
60	Protector, Oil	1
61	Collar	1
62	Switch Subassembly, Stop Engine	1
63	Gasket, Carburetor Insulator	1
64	Plate, Carburetor Insulator	1
65	Gasket, Carburetor	1
66	Gasket, Air Cleaner	1
67	Nut	2
68	Cleaner, Air	1
69	Gasket, Exhaust Outlet	1
70	Nut	2
71	Muffler Asm.	1
72	Tank, Fuel	1
73	Strainer, Fuel	1
74	Cover, Fuel Tank	1
75	Outlet Subassembly, Fuel Tank Oil	1
76	Collar	1
77	Tube, Fuel	1
78	Jacket, Rubber	1
79	Nut	2
80	Nut, Flywheel	1
81	Pulley, Starter	1
82	Impeller	1
83	Flywheel Subassembly	1
84	Bolt	2
85	Coil, Ignition	1
86	Support Subassembly, Governor	1
87	Nut	1
88	Bolt, Governor Support	1
89	Spring, Governor	1
90	Rod, Governor	1
91	Spring, Throttle Valve Returning	1
92	Control Asm, Throttle	1
93	Bolt	2

Assembly Diagram

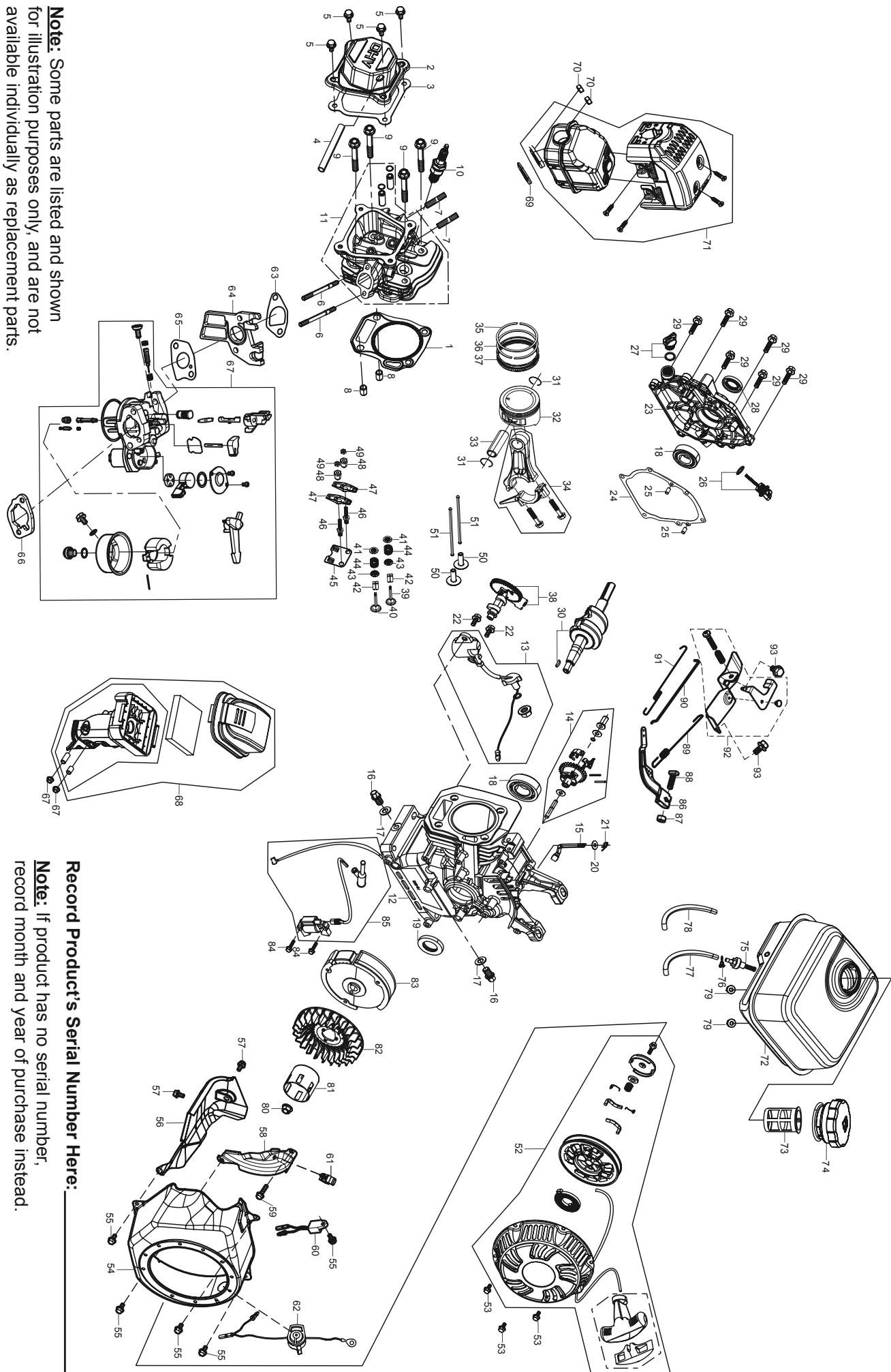

Note: Some parts are listed and shown for illustration purposes only, and are not available individually as replacement parts.

Record Product's Serial Number Here: _____

Note: If product has no serial number, record month and year of purchase instead.

Mounting Hole Diagram

SAFETY

SETUP

OPERATION

MAINTENANCE

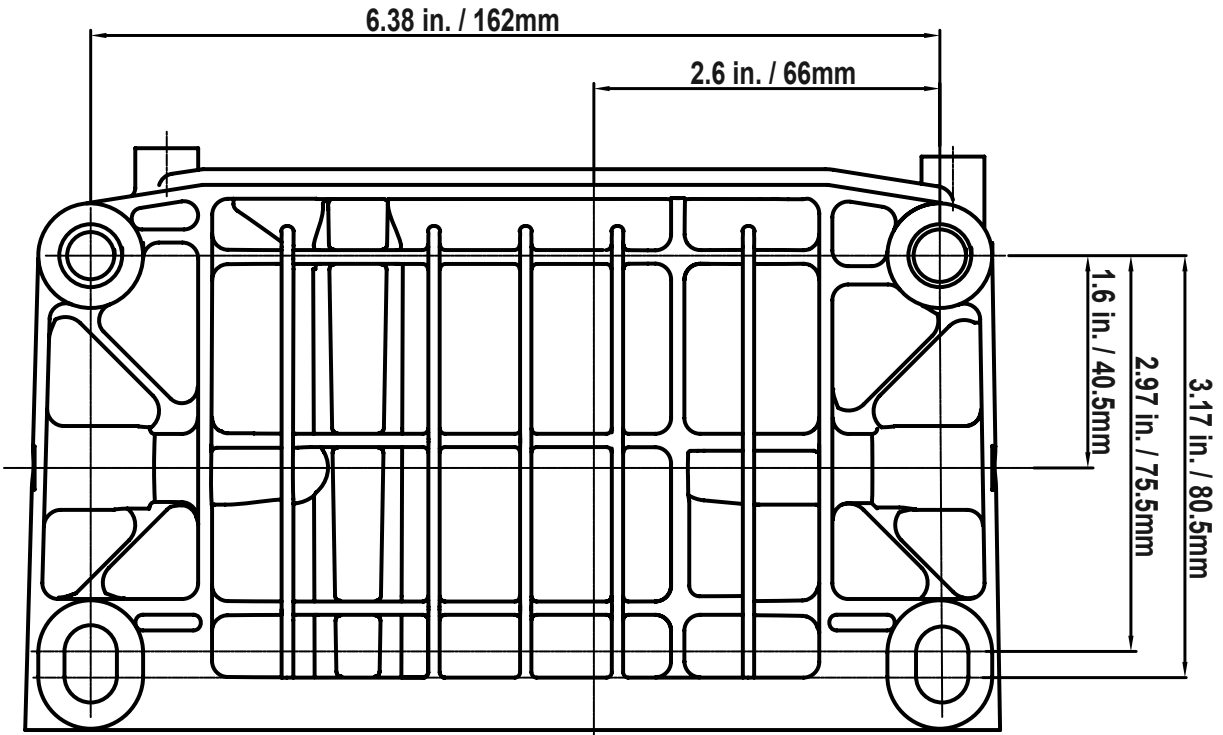

Power Take-Off Diagram

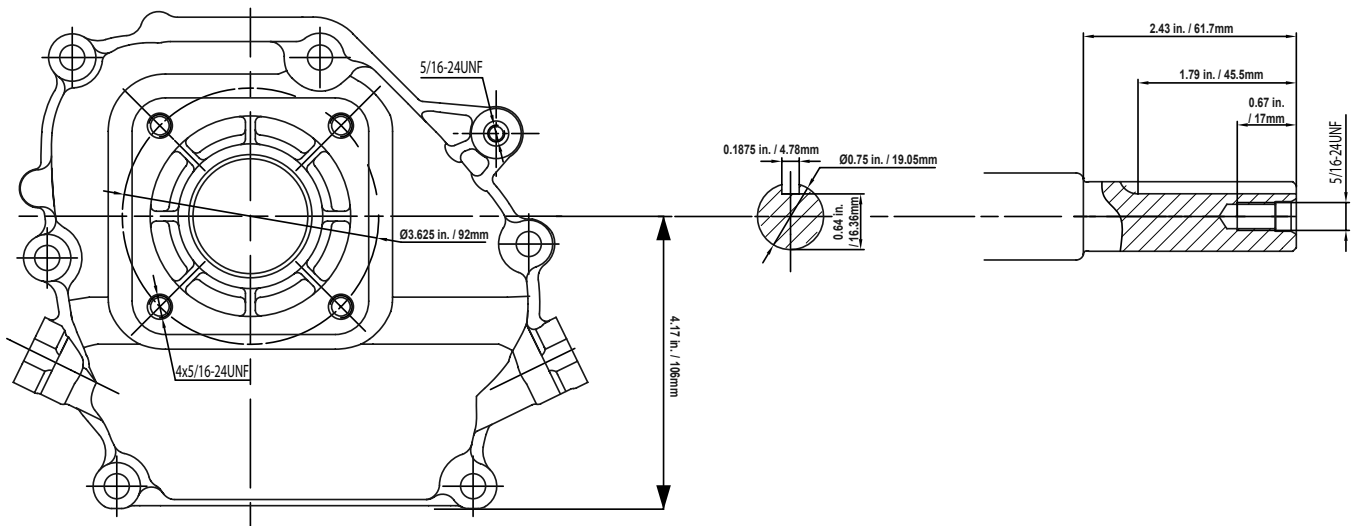

Note: Not to scale.

SAFETY

SETUP

OPERATION

MAINTENANCE

PLEASE READ THE FOLLOWING CAREFULLY

THE MANUFACTURER AND/OR DISTRIBUTOR HAS PROVIDED THE PARTS LIST AND ASSEMBLY DIAGRAM IN THIS MANUAL AS A REFERENCE TOOL ONLY. NEITHER THE MANUFACTURER OR DISTRIBUTOR MAKES ANY REPRESENTATION OR WARRANTY OF ANY KIND TO THE BUYER THAT HE OR SHE IS QUALIFIED TO MAKE ANY REPAIRS TO THE PRODUCT, OR THAT HE OR SHE IS QUALIFIED TO REPLACE ANY PARTS OF THE PRODUCT. IN FACT, THE MANUFACTURER AND/OR DISTRIBUTOR EXPRESSLY STATES THAT ALL REPAIRS AND PARTS REPLACEMENTS SHOULD BE UNDERTAKEN BY CERTIFIED AND LICENSED TECHNICIANS, AND NOT BY THE BUYER. THE BUYER ASSUMES ALL RISK AND LIABILITY ARISING OUT OF HIS OR HER REPAIRS TO THE ORIGINAL PRODUCT OR REPLACEMENT PARTS THERETO, OR ARISING OUT OF HIS OR HER INSTALLATION OF REPLACEMENT PARTS THERETO.

PREDATOR[®]
E N G I N E S

3491 Mission Oaks Blvd. • PO Box 6009 • Camarillo, CA 93011 • 1-888-866-5797