

Owner's Manual & Safety Instructions

Save This Manual Keep this manual for the safety warnings and precautions, assembly, operating, inspection, maintenance and cleaning procedures. Write the product's serial number in the back of the manual near the assembly diagram (or month and year of purchase if product has no number). Keep this manual and the receipt in a safe and dry place for future reference.

REV 15I

CHICAGO  **ELECTRIC**
POWER TOOLS

ITEM 62750

HEAVY DUTY MOBILE MITER SAW STAND

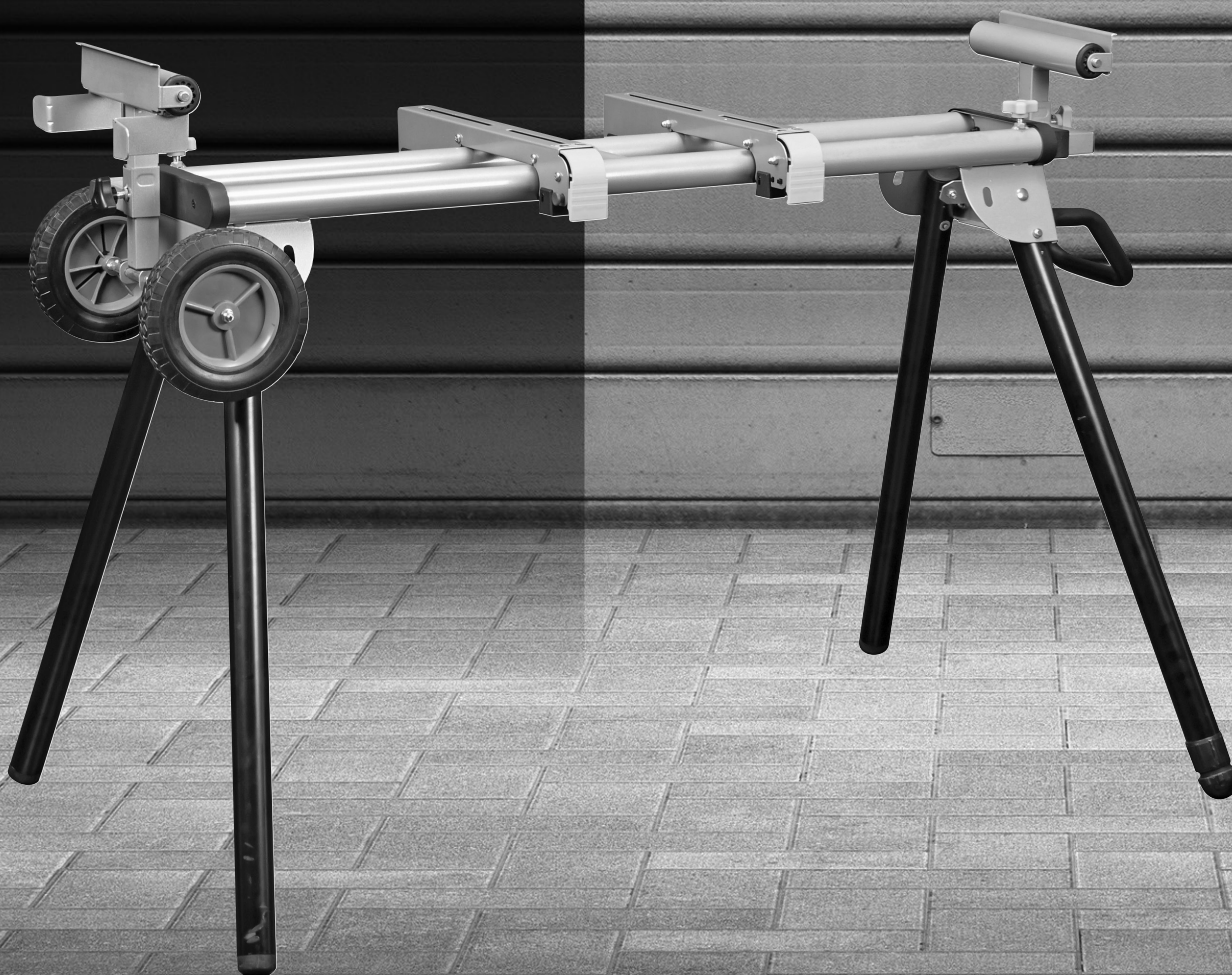

Visit our website at: <http://www.harborfreight.com>
Email our technical support at: productsupport@harborfreight.com

When unpacking, make sure that the product is intact and undamaged. If any parts are missing or broken, please call 1-888-866-5797 as soon as possible.

Copyright© 2015 by Harbor Freight Tools®. All rights reserved.
No portion of this manual or any artwork contained herein may be reproduced in any shape or form without the express written consent of Harbor Freight Tools. Diagrams within this manual may not be drawn proportionally. Due to continuing improvements, actual product may differ slightly from the product described herein.
Tools required for assembly and service may not be included.

WARNING

**Read this material before using this product.
Failure to do so can result in serious injury.
SAVE THIS MANUAL.**

Table of Contents





Safety	2	Maintenance	9
Specifications	4	Parts List and Diagram	10
Setup	4	Warranty	12
Operation	8		

SAFETY

CHICAGO ELECTRIC® POWER TOOLS

SETUP

WARNING SYMBOLS AND DEFINITIONS

	This is the safety alert symbol. It is used to alert you to potential personal injury hazards. Obey all safety messages that follow this symbol to avoid possible injury or death.
	Indicates a hazardous situation which, if not avoided, will result in death or serious injury.
	Indicates a hazardous situation which, if not avoided, could result in death or serious injury.
	Indicates a hazardous situation which, if not avoided, could result in minor or moderate injury.
	Addresses practices not related to personal injury.

OPERATION

IMPORTANT SAFETY INFORMATION

WARNING

Read all safety warnings and all instructions.

Failure to follow the warnings and instructions may result in electric shock, fire and/or serious injury.

Save all warnings and instructions for future reference.

- PRIOR TO USING THIS PRODUCT, READ AND UNDERSTAND ALL INSTRUCTIONS AND SAFETY PRECAUTIONS AS OUTLINED IN THE MANUFACTURER'S MANUAL OF THE MITER SAW THAT IS TO BE USED.**
- MAKE SURE THE MITER SAW STAND IS PLACED ON A FLAT, LEVEL, HARD SURFACE CAPABLE OF SUPPORTING THE WEIGHT OF THE MITER SAW STAND, MITER SAW BEING USED, AND WORKPIECE.**
- BOLT THE MITER SAW SECURELY TO THE MOUNTING BRACKETS ON THE MITER SAW STAND AND TEST WORK SET-UP FOR STABILITY BEFORE USE.**
- KEEP ALL GUARDS IN PLACE AND IN WORKING ORDER.**
- MAKE SURE THE WORKPIECE IS SUPPORTED AT ALL TIMES DURING OPERATION.** Use the two Extension Arms (2) with longer wood stock if necessary.
- UNPLUG THE MITER SAW FROM ITS ELECTRICAL SUPPLY SOURCE BEFORE PERFORMING ANY SERVICE OR MAINTENANCE ON THE MITER SAW STAND.** Make sure to unplug the Miter Saw before leaving the work area, moving the Miter Saw Stand from one location to another, cleaning sawdust from the unit, etc.
- Wear ANSI-approved safety goggles during assembly and use.**
- Do not exceed listed weight capacity. Be aware of dynamic loading!** Sudden load movement may briefly create excess load causing product failure.

MAINTENANCE

9. Weight capacity and other product capabilities apply to properly and completely assembled product only.
10. When folding or unfolding the Miter Saw Stand, be careful not to pinch fingers.
11. This product is not a toy.
Do not allow children to play with or near this item.
12. Use as intended only.
13. Keep hands clear of moving parts.
14. Maintain labels and nameplates on the tool. These carry important safety information. If unreadable or missing, contact Harbor Freight Tools for a replacement.
15. Stay alert, watch what you are doing and use common sense when operating a power tool. Do not use a power tool while you are tired or under the influence of drugs, alcohol or medication. A moment of inattention while operating power tools may result in serious personal injury.
16. **WARNING:** Some dust created by power sanding, sawing, grinding, drilling, and other construction activities, contains chemicals known to the State of California to cause cancer and birth defects or other reproductive harm. Some examples of these chemicals are:
 - Lead from lead-based paints
 - Crystalline silica from bricks and cement or other masonry products
 - Arsenic and chromium from chemically treated lumber
 Your risk from these exposures varies, depending on how often you do this type of work. To reduce your exposure to these chemicals: work in a well ventilated area, and work with approved safety equipment, such as those dust masks that are specially designed to filter out microscopic particles. (California Health & Safety Code § 25249.5, *et seq.*)
17. **WARNING:** This product contains di (2-ethylhexyl) phthalate (DEHP), a chemical known to the State of California to cause cancer and birth defects or other reproductive harm. (California Health & Safety Code § 25249.5, *et seq.*)
18. The warnings, precautions, and instructions discussed in this instruction manual cannot cover all possible conditions and situations that may occur. It must be understood by the operator that common sense and caution are factors which cannot be built into this product, but must be supplied by the operator.

Vibration Safety

Tools mounted on this Stand vibrate during use. Repeated or long-term exposure to vibration may cause temporary or permanent physical injury, particularly to the hands, arms and shoulders. To reduce the risk of vibration-related injury:

1. Anyone using vibrating tools regularly or for an extended period should first be examined by a doctor and then have regular medical check-ups to ensure medical problems are not being caused or worsened from use. Pregnant women or people who have impaired blood circulation to the hand, past hand injuries, nervous system disorders, diabetes, or Raynaud's Disease should not use this tool. If you feel any symptoms related to vibration (such as tingling, numbness, and white or blue fingers), seek medical advice as soon as possible.
2. Do not smoke during use. Nicotine reduces the blood supply to the hands and fingers, increasing the risk of vibration-related injury.
3. Wear suitable gloves to reduce the vibration effects on the user.
4. Use tools with the lowest vibration when there is a choice.
5. Include vibration-free periods each day of work.
6. Grip tool as lightly as possible (while still keeping safe control of it). Let the tool do the work.
7. To reduce vibration, maintain the tool as explained in this manual. If any abnormal vibration occurs, stop use immediately.
8. People with pacemakers should consult their physician(s) before use. Electromagnetic fields in close proximity to heart pacemaker could cause pacemaker interference or pacemaker failure. In addition, people with pacemakers should:
 - Avoid operating alone.
 - Properly maintain and inspect to avoid electrical shock.
 - Properly ground power cord. Ground Fault Circuit Interrupter (GFCI) should also be implemented – it prevents sustained electrical shock.



SAVE THESE INSTRUCTIONS.

Specifications

Maximum Load	400 lb (181 kg)
Maximum Extension	118"
Folded Dimensions	58-1/2" L x 13"W x 13"H
Wheel Diameter	7-3/4"
Weight	47 lb

Setup - Before Use



Read the **ENTIRE IMPORTANT SAFETY INFORMATION** section at the beginning of this manual including all text under subheadings therein before set up or use of this product.

Note: For additional information regarding the parts listed in the following pages, refer to *Parts List and Diagram* on page 10.

Set Up

1. Lay the Saw Stand upside down on the floor with folded legs facing upward.
2. Push in the Lock Pin (38) on one of the legs and tilt the leg upward until the Lock Pin clicks into place. Repeat with the other three legs.
3. Lift and turn the Saw Stand over to place in an upright, working position.
4. Make sure all Lock Pins are engaged and the Stand is stable.

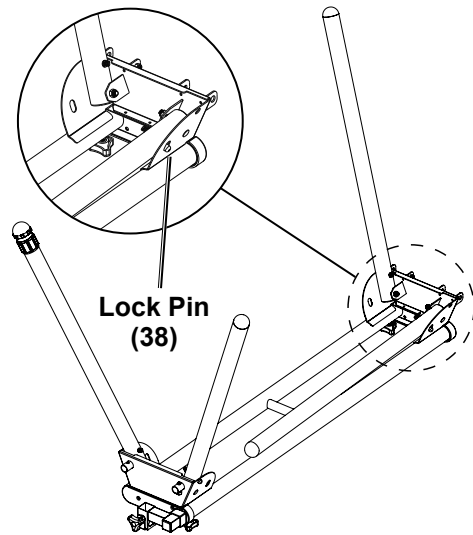

Figure A

5. To level the Saw Stand, first loosen the Locking Ring (44).
6. Turn the Adjustable Foot (45) clockwise to retract Foot or counter-clockwise to extend it.
7. Adjust the Adjustable Foot until the Stand is level and all four legs are in contact with the floor.
8. Tighten the Locking Ring securely.

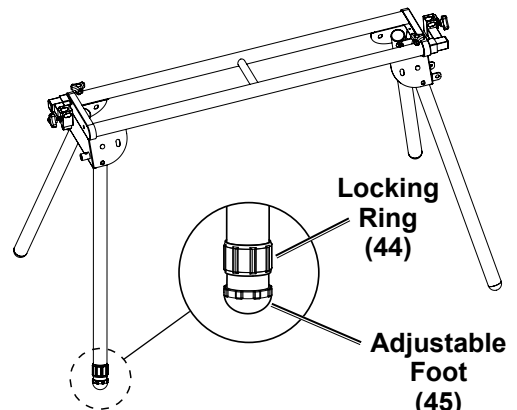
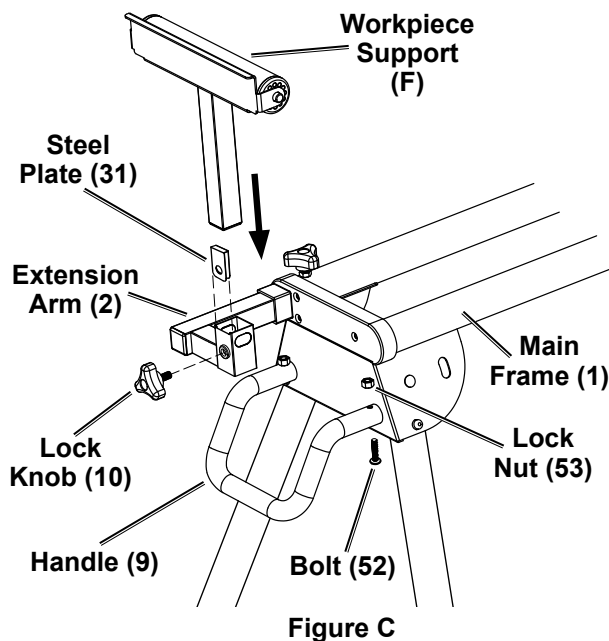

Figure B

Assembly

1. Insert the Handle (9) onto the two tubular brackets on the end of the Main Frame (1) and secure in place with two M6 x 35 Bolts (52) and M6 Lock Nuts (53). Refer to Figure C.
2. At the Handle end of the Stand, slide a protective Stainless Steel Plate (31) with the hole facing out onto the bracket at the end of the Extension Arm (2). Then insert the Workpiece Support (F) into the same bracket. Thread a Lock Knob (10) into the bracket and tighten to secure in place.
3. Repeat the procedure described in Step 2 at the Wheel end of the Stand for the other Workpiece Support (E, the Support with stand-up tabs) to attach it to the Stand.



4. Insert the two Wheel Axles (50) into the Brackets on the end of the Stand opposite the Handle and secure in place using one M8 Flat Washer (51) and M8 Lock Nut (47) per Axle. Refer to Figure D.
5. Place a Wheel (49) on each Wheel Axle and secure in place using one M8 Flat Washer (51) and M8 Lock Nut (47) per Wheel.

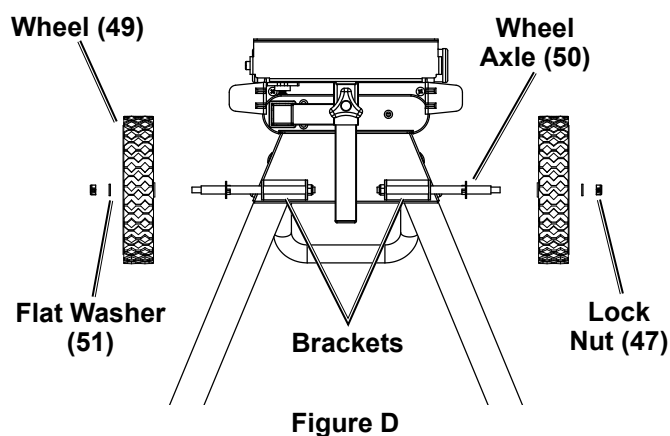

6. Press the Locking Buttons (13) on the Mounting Brackets (5, 6) and pull up on the Locking Handles (11, 37) to open them.
7. Place the Mounting Brackets in parallel on the Saw Stand. Push the Locking Handles down until the Locking Buttons click into place to secure.
8. Insert four M8 x 40 Carriage Bolts (54) through slots on Mounting Brackets from underside and hold in place with M8 Lock Washers (55).

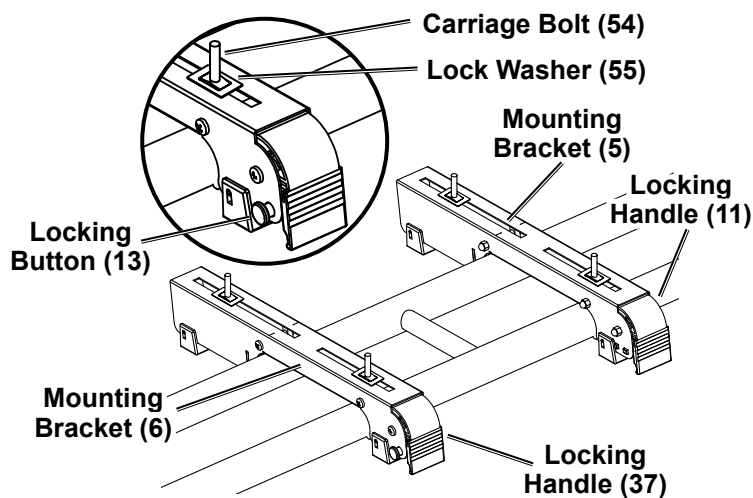

- Adjust the position of the Carriage Bolts on the Mounting Brackets and the position of the Mounting Brackets on the Saw Stand to align with mounting holes on the miter saw base.

CAUTION! Make sure the miter saw (not included) is unplugged from its electrical power supply source before attempting to mount on the Miter Saw Stand.

- With assistance, lower the miter saw onto the Mounting Brackets, making sure the Carriage Bolts on the Brackets pass through the mounting holes on the miter saw base.
- Secure the miter saw in place on the Mounting Brackets using M8 Flat Washers (51), M8 Spring Washers (57), and M8 Nuts (56) on the Carriage Bolts.

Note: If the miter saw does not have at least four mounting holes that line up with the bolts on the Mounting Brackets, it will need to be attached using a universal mounting platform, as explained below.

- To remove the miter saw with attached Mounting Brackets from the Miter Saw Stand, press the Locking Buttons on the Mounting Brackets to open the Locking Handles and lift the miter saw off of the Stand.

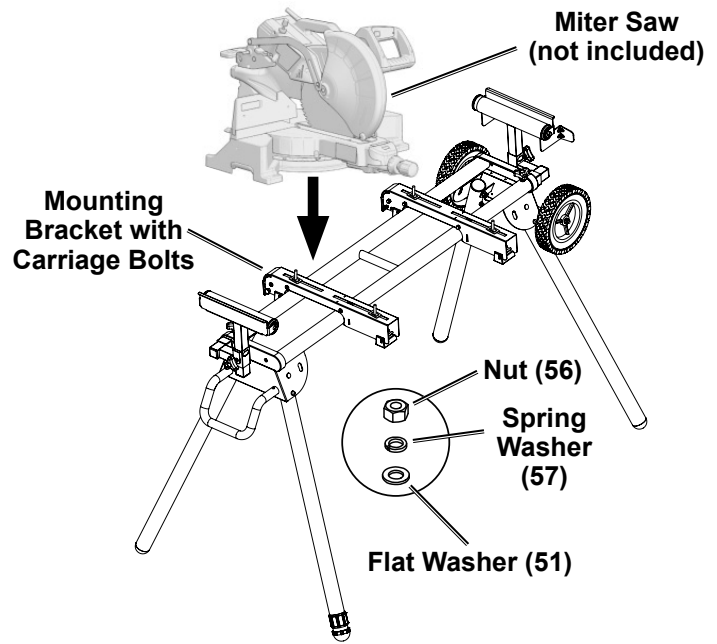

Figure F

Universal Mounting Platform

- For miter saws with unusual mounting patterns, a mounting platform can be used. Use minimum 3/4" thick plywood that is at least 4" wider than the widest part of the miter saw base and at least as deep as the smallest depth of the miter saw base or a minimum of 16", whichever is larger.
- Ensure the plywood is square and drill 3/8" holes in the four corners, 1" in from the sides.
- Attach the Mounting Brackets to the Stand as described in *Assembly*, steps 6 to 8 on page 5.
- Adjust the position of the Carriage Bolts on the Mounting Brackets and the position of the Mounting Brackets on the Saw Stand to align with mounting holes on the plywood platform.
- Attach the plywood platform to the Mounting Brackets using M8 Flat Washers (51), M8 Spring Washers (57), and M8 Nuts (56) on the Carriage Bolts.
- Place the miter saw in the chosen location on the platform and use mounting holes in the miter saw base as a template to mark mounting hole locations on the plywood. Remove saw and drill holes at marked locations of an appropriate size for the mounting hardware to be used. Use the largest diameter hardware possible.
- Mount miter saw to plywood platform using four bolts (grade 5 or better), flat washers, lock washers, and nuts (not included). Tighten all hardware securely.

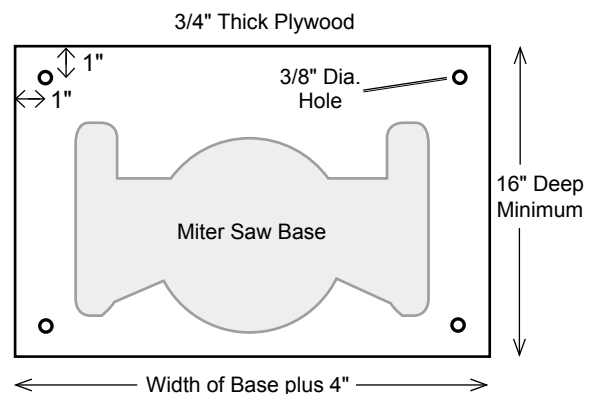
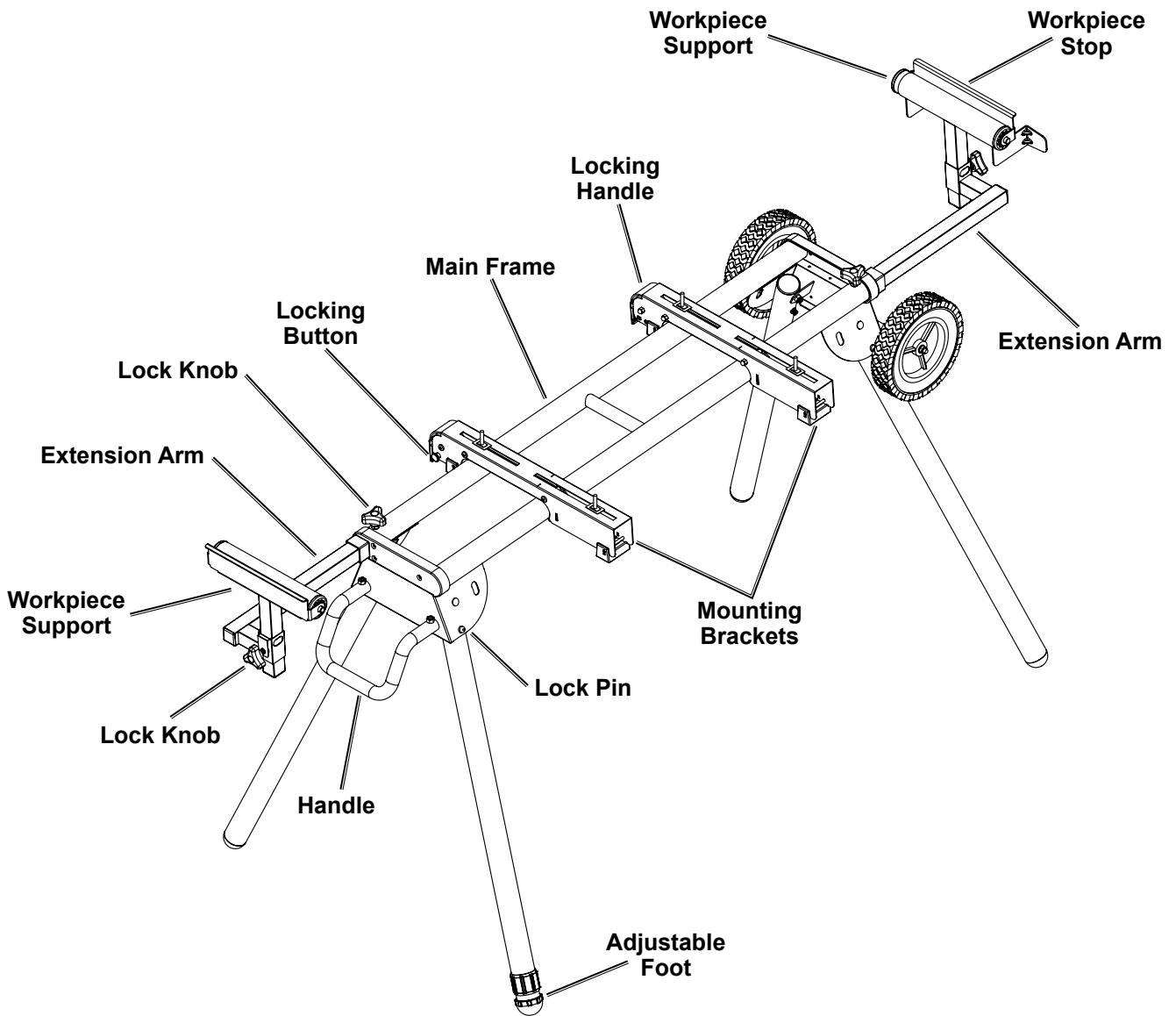

Figure G

Components and Controls



CHICAGO  **ELECTRIC**[®]
POWER TOOLS

Operation



Read the **ENTIRE IMPORTANT SAFETY INFORMATION** section at the beginning of this manual including all text under subheadings therein before set up or use of this product.

WARNING

TO PREVENT SERIOUS INJURY: Read the miter saw manufacturer's instruction manual before use. Ensure that the miter saw is firmly secured to the stand. Use as a miter saw stand only – do not use with any other type of power tool. Do not exceed listed weight capacity. Do not use on uneven or slippery surfaces.

Extension Arms

1. To use the Extension Arms (2) to provide support for longer workpieces, loosen the Lock Knob (10) to unlock the Arm.
2. Extend the Extension Arm to the desired length.
3. Tighten the Lock Knob to secure the Extension Arm in place.

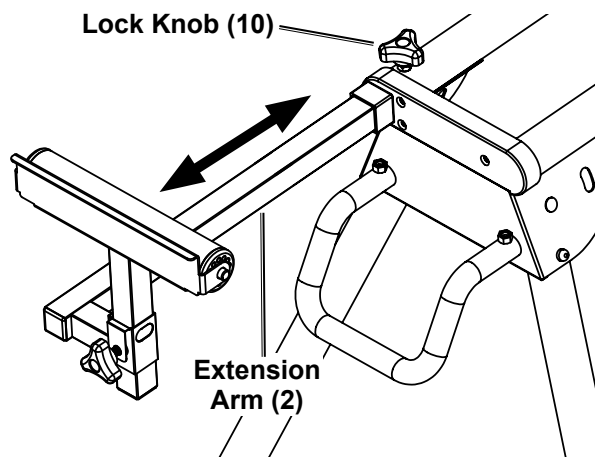

Figure H

Workpiece Supports

1. To adjust the height of the Workpiece Supports (E, F), loosen the Lock Knob (10) at the end of either Extension Arm and raise the Support so it is level with the miter saw table top.

CAUTION! Ensure that workpiece lays flat on miter saw table or saw blade may bind when cutting.

2. Tighten the Lock Knob and adjust the other Workpiece Support in same manner.

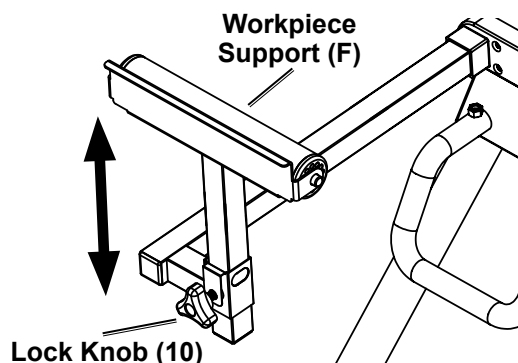

Figure I

Workpiece Stops

1. Use the Workpiece Stop (33) to make multiple cuts of the same length. Rotate the Workpiece Stop up to its engaged position. Refer to Figure J.
2. Position the Workpiece Support at the desired length setting by extending or retracting the Extension Arm (2).

CAUTION! Do not use both Workpiece Stops at the same time or saw blade may bind in the workpiece when cutting.

3. When finished rotate the Workpiece Stop down to its normal position.

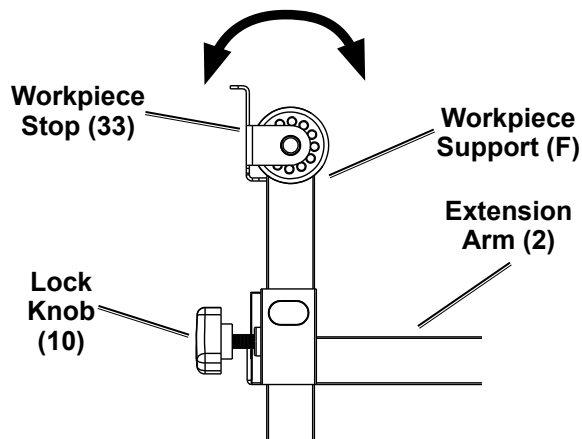

Figure J

Maintenance



Procedures not specifically explained in this manual must be performed only by a qualified technician.

WARNING

TO PREVENT SERIOUS INJURY FROM ACCIDENTAL OPERATION:

Turn the power switch of the miter saw mounted on the Miter Saw Stand off, and unplug the tool from its electrical outlet before performing any procedure in this section.

TO PREVENT SERIOUS INJURY FROM TOOL FAILURE:

Do not use damaged equipment. If abnormal noise or vibration occurs, have the problem corrected before further use.

- BEFORE EACH USE**, inspect the general condition of the Miter Saw Stand. Check for:
 - loose hardware
 - misalignment or binding of parts
 - cracked or broken parts
 - loose or improper mounting of the miter saw
 - any other condition that may affect its safe operation.
- AFTER USE**, wipe external surfaces of the Stand with clean cloth.
- Periodically, lightly lubricate all moving parts of the Miter Saw Stand.

Adjusting the Mounting Brackets

After extensive use of the Miter Saw Stand, the Mounting Brackets may require readjustment. If the Mounting Brackets can be removed from the Saw Stand rails when the Locking Handles are locked, the bracket adjustment screws should be tightened. If the Mounting Brackets will not fit over the Saw Stand rails, the bracket adjustment screws should be loosened. To adjust the Mounting Brackets:

- Remove the miter saw with attached Mounting Brackets from the Stand, then remove the Brackets from the miter saw.
- Use a wrench to loosen the M6 Nut (24) which locks the M6 x 30 Adjustment Screw (23) in place. Refer to Figure K.
- Using a phillips screwdriver, turn the Adjustment Screw clockwise to tighten the Mounting Bracket or counterclockwise to loosen the Bracket.
- Check the adjustment by re-installing the Mounting Bracket on the Miter Saw Stand rails and closing the Locking Handle.
- Once the proper setting is attained, tighten the Nut to secure the Adjustment Screw.
- Adjust the other Mounting Bracket in same manner.

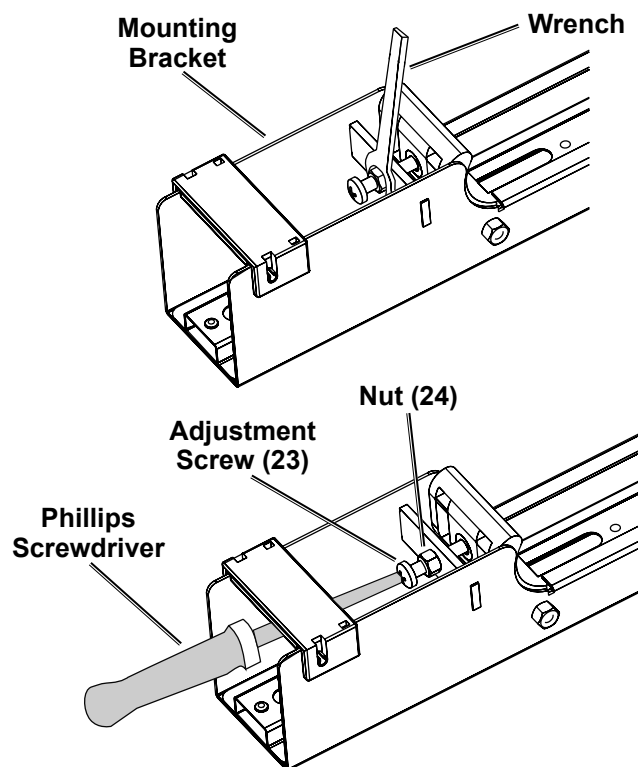

Figure K

PLEASE READ THE FOLLOWING CAREFULLY

THE MANUFACTURER AND/OR DISTRIBUTOR HAS PROVIDED THE PARTS LIST AND ASSEMBLY DIAGRAM IN THIS MANUAL AS A REFERENCE TOOL ONLY. NEITHER THE MANUFACTURER OR DISTRIBUTOR MAKES ANY REPRESENTATION OR WARRANTY OF ANY KIND TO THE BUYER THAT HE OR SHE IS QUALIFIED TO MAKE ANY REPAIRS TO THE PRODUCT, OR THAT HE OR SHE IS QUALIFIED TO REPLACE ANY PARTS OF THE PRODUCT. IN FACT, THE MANUFACTURER AND/OR DISTRIBUTOR EXPRESSLY STATES THAT ALL REPAIRS AND PARTS REPLACEMENTS SHOULD BE UNDERTAKEN BY CERTIFIED AND LICENSED TECHNICIANS, AND NOT BY THE BUYER. THE BUYER ASSUMES ALL RISK AND LIABILITY ARISING OUT OF HIS OR HER REPAIRS TO THE ORIGINAL PRODUCT OR REPLACEMENT PARTS THERETO, OR ARISING OUT OF HIS OR HER INSTALLATION OF REPLACEMENT PARTS THERETO.

Parts List

Part	Description	Qty
1	Main Frame	1
2	Extension Arm	2
3	Right Workpiece Support	1
4	Left Workpiece Support	1
5	Right Mounting Bracket	1
6	Leftt Mounting Bracket	1
7	Leg	3
8	Adjustable Leg	1
9	Handle	1
10	Lock Knob	4
11	Right Locking Handle	1
12	Locking Mechanism	2
13	Locking Button	2
14	Spring	2
15	Mounting Bracket Base	4
16	Cam	4
17	Clamp	2
18	Adjustable Clamp	2
19	Protective Cap	2
20	M6x56 Bolt	6
21	M6 Cover Nut	6
22	Ø5 Spring Pin	4
23	M6x30 Bolt	2
24	M6 Nut	8
25	Extension Arm Cap	2
26	Table Cap	2
27	M4x8 Rivet	4
28	M4x10 Rivet	4
29	M5 Spring Washer	8

Part	Description	Qty
30	Frame End Cap	4
31	Stainless Steel Plate	2
32	Roller Axle	2
33	Workpiece Stop	2
34	Roller Cap	4
35	Spring	2
36	M12 Flat Washer	6
37	Left Locking Handle	1
38	Lock Pin	3
39	Foot	3
40	Leg Cap	3
41	Ø8 Spring	3
42	Ø4 E-Ring	3
43	M6 Flat Washer	3
44	Locking Ring	1
45	Adjustable Foot	1
46	M8x62 Bolt	4
47	M8 Lock Nut	8
48	M6x10 Bolt	6
49	Wheel	2
50	Wheel Axle	2
51	M8 Flat Washer	8
52	M6x35 Bolt	2
53	M6 Lock Nut	2
54	M8x40 Bolt	4
55	M8 Lock Washer	4
56	M8 Nut	4
57	M8 Spring Washer	4

Record Product's Serial Number Here: _____

Note: If product has no serial number, record month and year of purchase instead.

Note: Some parts are listed and shown for illustration purposes only, and are not available individually as replacement parts.

Assembly Diagram

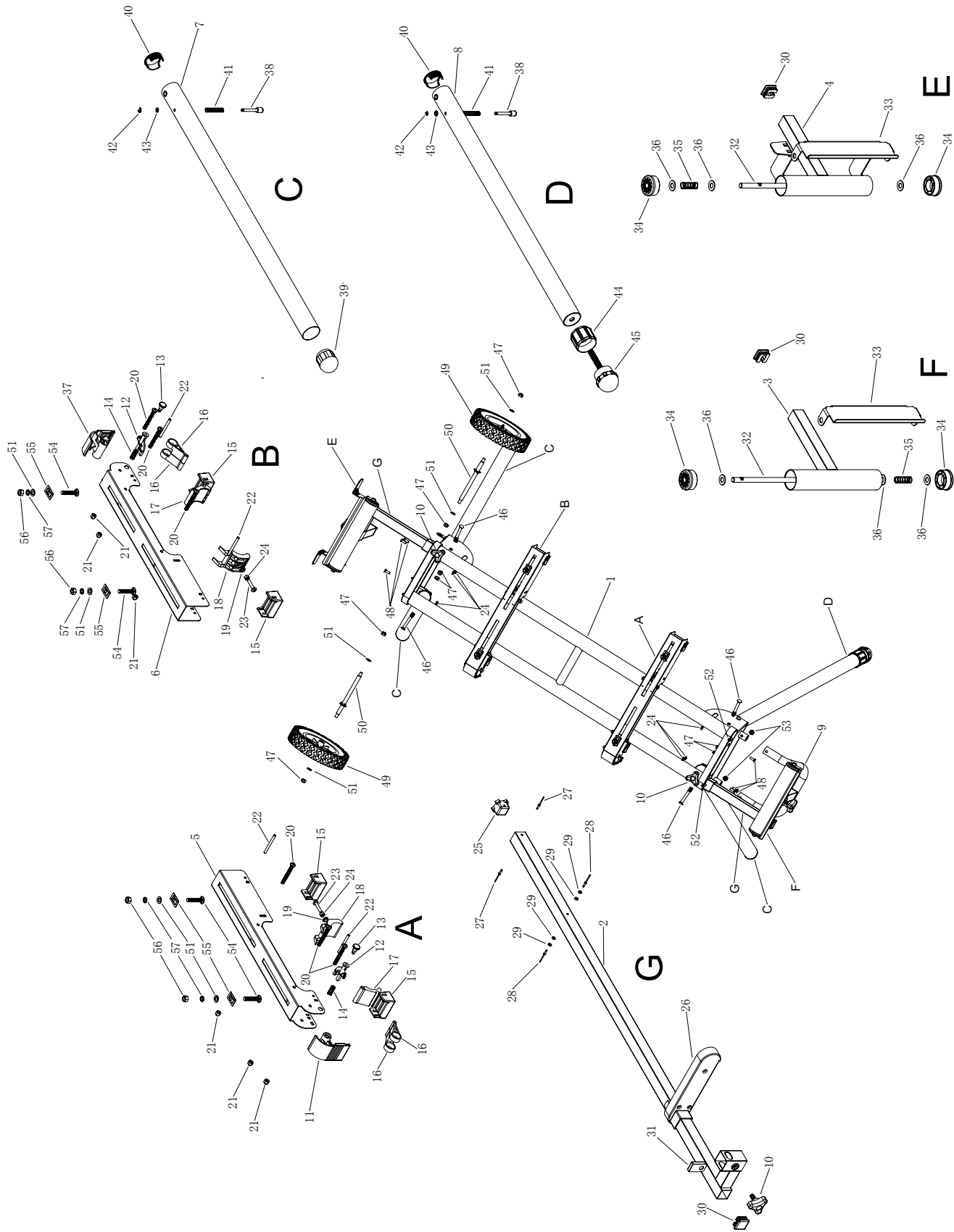

SAFETY

SETUP

OPERATION

MAINTENANCE

Limited 90 Day Warranty

Harbor Freight Tools Co. makes every effort to assure that its products meet high quality and durability standards, and warrants to the original purchaser that this product is free from defects in materials and workmanship for the period of 90 days from the date of purchase. This warranty does not apply to damage due directly or indirectly, to misuse, abuse, negligence or accidents, repairs or alterations outside our facilities, criminal activity, improper installation, normal wear and tear, or to lack of maintenance. We shall in no event be liable for death, injuries to persons or property, or for incidental, contingent, special or consequential damages arising from the use of our product. Some states do not allow the exclusion or limitation of incidental or consequential damages, so the above limitation of exclusion may not apply to you. THIS WARRANTY IS EXPRESSLY IN LIEU OF ALL OTHER WARRANTIES, EXPRESS OR IMPLIED, INCLUDING THE WARRANTIES OF MERCHANTABILITY AND FITNESS.

To take advantage of this warranty, the product or part must be returned to us with transportation charges prepaid. Proof of purchase date and an explanation of the complaint must accompany the merchandise. If our inspection verifies the defect, we will either repair or replace the product at our election or we may elect to refund the purchase price if we cannot readily and quickly provide you with a replacement. We will return repaired products at our expense, but if we determine there is no defect, or that the defect resulted from causes not within the scope of our warranty, then you must bear the cost of returning the product.

This warranty gives you specific legal rights and you may also have other rights which vary from state to state.

CHICAGO  ELECTRIC®
POWER TOOLS

3491 Mission Oaks Blvd. • PO Box 6009 • Camarillo, CA 93011 • 1-888-866-5797