

Owner's Manual & Safety Instructions

Save This Manual Keep this manual for the safety warnings and precautions, assembly, operating, inspection, maintenance and cleaning procedures. Write the product's serial number in the back of the manual near the assembly diagram (or month and year of purchase if product has no number). Keep this manual and the receipt in a safe and dry place for future reference.

REV 15k

CENTRALPNEUMATIC®

30GAL gas powered two-stage air compressor

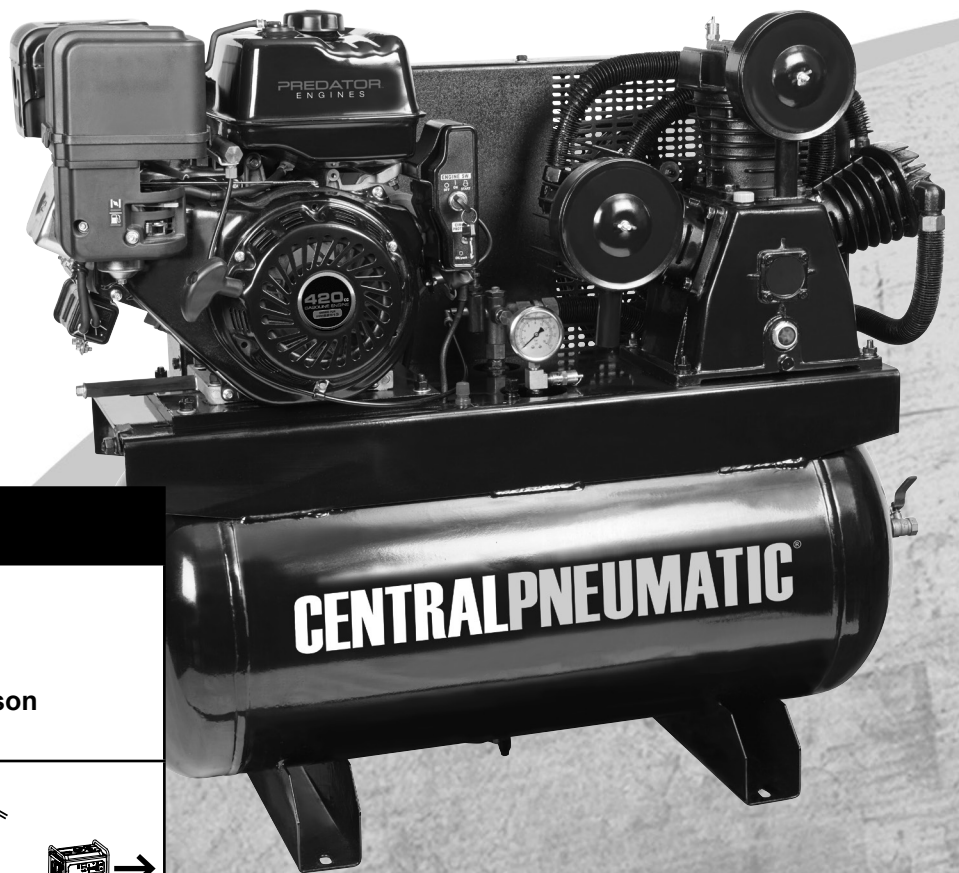

⚠ DANGER

Using a generator indoors **CAN KILL YOU IN MINUTES.**

Generator exhaust contains carbon monoxide. This is a poison you cannot see or smell.



NEVER use inside a home or garage, **EVEN IF** doors and windows are open.

Only use **OUTSIDE** and far away from windows, doors, and vents.

Visit our website at: <http://www.harborfreight.com>
Email our technical support at: productsupport@harborfreight.com

ITEM 62913

When unpacking, make sure that the product is intact and undamaged. If any parts are missing or broken, please call 1-888-866-5797 as soon as possible.

Copyright© 2015 by Harbor Freight Tools®. All rights reserved.
No portion of this manual or any artwork contained herein may be reproduced in any shape or form without the express written consent of Harbor Freight Tools. Diagrams within this manual may not be drawn proportionally. Due to continuing improvements, actual product may differ slightly from the product described herein.
Tools required for assembly and service may not be included.

⚠ WARNING

Read this material before using this product. Failure to do so can result in serious injury. SAVE THIS MANUAL.

Table of Contents

Safety	2	Maintenance	14
Installation	2	Parts List and Diagram	18
Specifications	6	Warranty	20
Operation.....	10		





SAFETY

CENTRALPNEUMATIC®

INSTALLATION

OPERATION

MAINTENANCE

WARNING SYMBOLS AND DEFINITIONS	
	This is the safety alert symbol. It is used to alert you to potential personal injury hazards. Obey all safety messages that follow this symbol to avoid possible injury or death.
	Indicates a hazardous situation which, if not avoided, will result in death or serious injury.
	Indicates a hazardous situation which, if not avoided, could result in death or serious injury.
	Indicates a hazardous situation which, if not avoided, could result in minor or moderate injury.
	Addresses practices not related to personal injury.

IMPORTANT SAFETY INFORMATION

General Safety Warnings



WARNING Read all safety warnings and instructions.

Failure to follow the warnings and instructions may result in electric shock, fire and/or serious injury.

Save all warnings and instructions for future reference.

The warnings, precautions, and instructions discussed in this instruction manual cannot cover all possible conditions and situations that may occur. It must be understood by the operator that common sense and caution are factors which cannot be built into this product, but must be supplied by the operator.

Set Up Precautions

1. **Keep work area clean and well lit.**
Cluttered or dark areas invite accidents.
2. **Do not operate the Compressor in explosive atmospheres, such as in the presence of flammable liquids, gases or dust.** Gasoline-powered engines may ignite the dust or fumes.
3. **Keep children and bystanders away from an operating compressor.**
4. Gasoline fuel and fumes are flammable, and potentially explosive. Use proper fuel storage and handling procedures. Do not store fuel or other flammable materials nearby.
5. Have multiple ABC class fire extinguishers nearby.
6. Operation of this equipment may create sparks that can start fires around dry vegetation. A spark arrestor may be required. The operator should contact local fire agencies for laws or regulations relating to fire prevention requirements.
7. Set up and use only on a flat, level, well-ventilated surface.
8. Use only lubricants and fuel recommended in the engine manual or in the Specifications chart of this manual.
9. Wear ANSI-approved safety glasses, hearing protection, and NIOSH-approved dust mask/respirator under a full face shield along with steel-toed work boots during use.
10. Do not overreach. Keep proper footing and balance at all times. This enables better control of the equipment in unexpected situations.
11. Dress properly. Do not wear loose clothing or jewelry. Keep hair, clothing and gloves away from moving parts. Loose clothes, jewelry or long hair can be caught in moving parts.

Engine Precautions

Follow engine precautions and instructions in the included engine instruction manual.

Personal Safety

1. **Stay alert, watch what you are doing and use common sense when operating this compressor. Do not use this compressor while you are tired or under the influence of drugs, alcohol or medication.** A moment of inattention while operating a compressor may result in serious personal injury.
2. **Use personal protective equipment. Always wear ANSI-approved eye protection during setup and use.**
3. **Prevent unintentional starting. Ensure the switch is in the off-position before moving the compressor.**

Operating Precautions

SAFETY

1.  **CARBON MONOXIDE HAZARD**
Using an engine indoors CAN KILL YOU IN MINUTES.
Engine exhaust contains carbon monoxide. This is a poison you cannot see or smell.

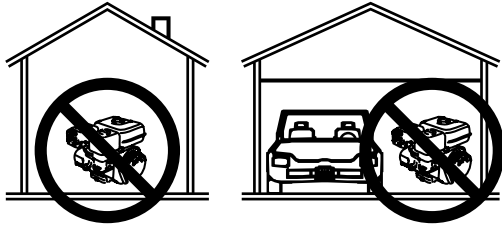

NEVER use inside a home or garage, EVEN IF doors and windows are open.

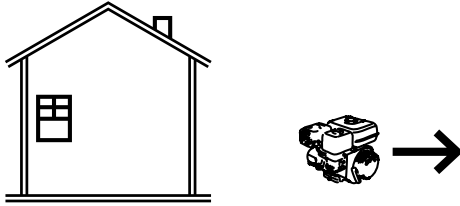

Only use OUTSIDE and far away from windows, doors, and vents.

2. Keep children away from the equipment, especially while it is operating.
3. Fire Hazard! Do not fill gas tank while Compressor engine is running. Do not operate if gasoline has been spilled. Clean spilled gasoline before starting engine. Do not operate near pilot light or open flame.
4. Do not touch Compressor engine during use. Let engine cool down after use.
 - a. **Do not use the compressor if the switch does not turn it on and off.** Any compressor that cannot be controlled with the switch is dangerous and must be repaired.
 - b. **Store an idle compressor out of the reach of children and do not allow persons unfamiliar with the compressor or these instructions to operate it.** A compressor is dangerous in the hands of untrained users.
5. Never store fuel or other flammable materials near the Compressor engine.
6. Only use a suitable means of transport and lifting devices with sufficient weight bearing capacity when transporting the Compressor.

INSTALLATION

OPERATION

MAINTENANCE

7. Secure the Compressor on transport vehicles to prevent the tool from rolling, slipping, and tilting.
8. Use only accessories that are recommended by Harbor Freight Tools for your model. Accessories that may be suitable for one piece of equipment may become hazardous when used on another piece of equipment.
9. Parts, especially exhaust system components, get very hot during use. Stay clear of hot parts.
10. Do not cover the engine or equipment during operation.
11. **Maintain the compressor. Keep the compressor clean for better and safer performance. Follow instructions for lubricating and changing accessories. Keep dry, clean and free from oil and grease. Check for misalignment or binding of moving parts, breakage of parts and any other condition that may affect the compressor's operation. If damaged, have the compressor repaired before use.** Many accidents are caused by a poorly maintained compressor.
12. **Use the compressor in accordance with these instructions, taking into account the working conditions and the work to be performed.** Use of the compressor for operations different from those intended could result in a hazardous situation.
13. Do not operate the equipment with known leaks in the engine's fuel system.
14. When spills of fuel or oil occur, they must be cleaned up immediately. Dispose of fluids and cleaning materials as per any local, state, or federal codes and regulations. Store oil rags in a bottom-ventilated, covered, metal container.
15. Keep hands and feet away from moving parts. Do not reach over or across equipment while operating.
16. Before use, check for misalignment or binding of moving parts, breakage of parts, and any other condition that may affect the equipment's operation. **If damaged, have the equipment serviced before using.** Many accidents are caused by poorly maintained equipment.
17. Use the correct equipment for the application. Do not modify the equipment and do not use the equipment for a purpose for which it is not intended.

Service Precautions

Have your compressor serviced by a qualified repair person using only identical replacement parts. This will ensure that the safety of the compressor is maintained.

1. **Before service, maintenance, or cleaning:**
 - a. Turn the engine switch to its "OFF" position.
 - b. Allow the engine to completely cool.
 - c. Then, remove the spark plug cap from the spark plug.
2. Keep all safety guards in place and in proper working order. Safety guards include muffler, air cleaner, mechanical guards, and heat shields, among other guards.
3. **Do not alter or adjust any part of the equipment or its engine that is sealed by the manufacturer or distributor. Only a qualified service technician may adjust parts that may increase or decrease governed engine speed.**
4. Wear ANSI-approved safety goggles, heavy-duty work gloves, and dust mask/respirator during service.
5. Maintain labels and nameplates on the equipment. These carry important information. If unreadable or missing, contact Harbor Freight Tools for a replacement.
6. Store equipment out of the reach of children.
7. Follow scheduled engine and equipment maintenance.

Air Compressor Safety Warnings

1. **Risk of fire or explosion - do not spray flammable liquid in a confined area or towards a hot surface. Spray area must be well-ventilated. Do not smoke while spraying or spray where spark or flame is present. Arcing parts - keep compressor at least 20 feet away from explosive vapors, such as when spraying with a spray gun.**
2. **Risk of bursting - do not adjust regulator higher than marked maximum pressure of attachment.**
3. **Risk of injury - do not direct air stream at people or animals.**
4. **Do not use to supply breathing air.**
5. **Keep compressor well-ventilated. Do not cover compressor during use.**
6. **Add correct amount of compressor oil before first use and every use. Operating with the incorrect amount of oil causes permanent damage and voids warranty. To prevent damage, do not use with overfilled or low oil.**
7. Drain Tank daily and after use. Internal rust causes tank failure and explosion.
8. Do not remove the valve cover or adjust internal components.
9. Compressor head gets hot during operation. Do not touch it or allow children nearby during or immediately following operation.
10. Do not use the air hose to move the compressor.
11. Release the pressure in the storage tank before moving.
12. The use of accessories or attachments not recommended by the manufacturer may result in a risk of injury to persons.
13. All air line components, including hoses, pipe, connectors, filters, etc., must be rated for a minimum working pressure of 150 PSI, or 150% of the maximum system pressure, whichever is greater.
14. Industrial applications must follow OSHA guidelines.
15. Maintain labels and nameplates on the compressor. These carry important safety information. If unreadable or missing, contact Harbor Freight Tools for a replacement.
16. This product is not a toy. Keep it out of reach of children.
17. People with pacemakers should consult their physician(s) before use. Electromagnetic fields in close proximity to heart pacemaker could cause pacemaker interference or pacemaker failure. Caution is necessary when near the engine's magneto or recoil starter.
18. **WARNING: The brass components of this product contain lead, a chemical known to the State of California to cause cancer and birth defects or other reproductive harm. (California Health & Safety Code § 25249.5, et seq.)**
19. **WARNING: The cord of this product contains lead and/or di (2-ethylhexyl) phthalate (DEHP), chemicals known to the State of California to cause cancer, and birth defects or other reproductive harm. Wash hands after handling. (California Health & Safety Code § 25249.5, et seq.)**



SAVE THESE INSTRUCTIONS.

Grounding

⚠ WARNING





TO PREVENT ELECTRIC SHOCK AND DEATH FROM INCORRECT GROUNDING WIRE CONNECTION:

Check with a qualified electrician if you are in doubt as to whether the is properly grounded. Do not use the compressor if the power cord is damaged. If damaged, have it repaired by a service facility before use.

Symbology

PSI	Pounds per square inch of pressure
CFM	Cubic Feet per Minute flow
SCFM	Cubic Feet per Minute flow at standard conditions
NPT	National pipe thread, tapered
NPS	National pipe thread, straight

RPM	Revolutions Per Minute
HP	Horsepower
	WARNING marking concerning Risk of Eye Injury. Wear ANSI-approved safety goggles with side shields.
	WARNING marking concerning Risk of Respiratory Injury. Operate engine OUTSIDE and far away from windows, doors, and vents.
	WARNING marking concerning Risk of Explosion.

Specifications

Pump	Two stage	
Air Outlet Size	1/2" -18 NPT	
Air Pressure	Shut-off	180 PSI
	Restart	140 PSI
Air Tank Capacity	30 Gallons	
Air Flow Capacity	18 SCFM @ 90 PSI	
	19.5 SCFM @ 40 PSI	

Oil Capacity	57 oz. (1.7L)
Oil Type	SAE 30 non-detergent Air Compressor Oil
Required Rotation viewed from PTO (power takeoff - the output shaft)	Clockwise
Required Engine Idle Speed	2000 RPM ± 100 RPM

Note: Engine specifications are found in the engine manual supplied with this equipment.

Installation



Read the **ENTIRE IMPORTANT SAFETY INFORMATION** section at the beginning of this manual including all text under subheadings therein before set up or use of this product.

The emission control system for this Compressor's Engine is warranted for standards set by the U.S. Environmental Protection Agency and by the California Air Resources Board (also known as CARB). For warranty information, refer to the engine manual.

Note: For additional information regarding the parts listed in the following pages, refer to the Assembly Diagram near the end of this manual.

Functions

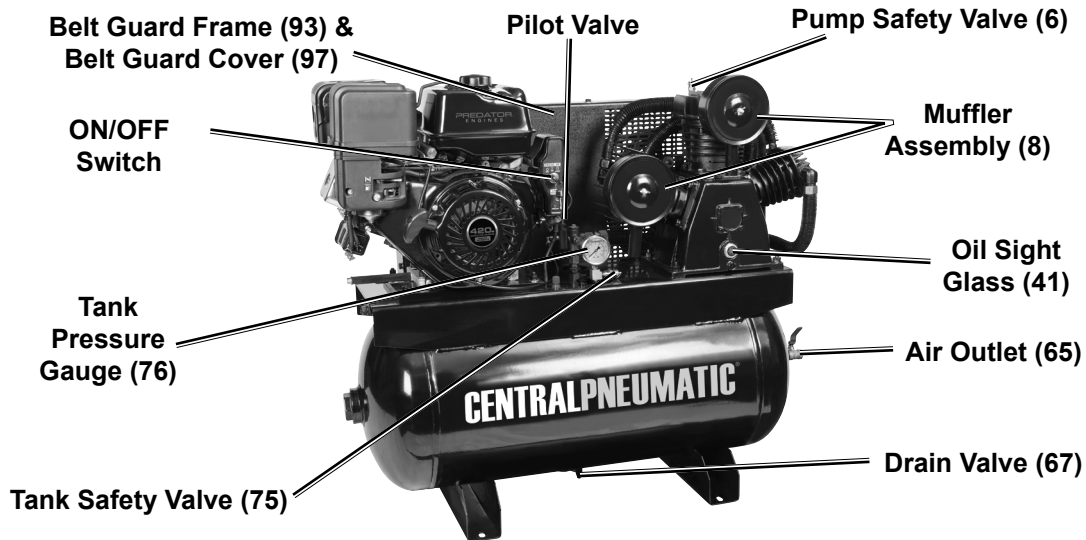

1. **Belt Guard** - The Belt Guard encloses the pulleys and drive belts. It protects the user from the moving parts and allows the large pulley to direct cooling air to the Air Pump.
2. **Oil Sight Glass** - The oil sight glass shows proper level of the oil. Oil level should be at center of Sight Glass.
3. **Tank Drain Valve** - The Air Tank Drain Valve allows moisture to be removed from the tank to prevent corrosion.
4. **Safety Valve** - The Safety Valve automatically releases air if the Air Tank pressure exceeds the preset maximum. In an emergency, the ring can be pulled to relieve tank air pressure. There is one safety valve on the pump and one on the tank.
5. **Air Outlet** - An air hose attaches to this valve. Air pressure required by tools is set by an air pressure regulator.
6. **Air Storage Tank** - The Air Tank is where air pressurized by the Air Pump is stored for use.
7. **Tank Pressure Gauge** - The Air Tank Pressure Gauge displays the air pressure in the tank.
8. **Pilot Valve** - Open the Pilot Valve before starting the engine. It relieves resistance on the engine to make starting possible. Rotate the pin so it is vertical to open it. Once the engine is running, close the Pilot Valve so the Compressor can build up pressure.

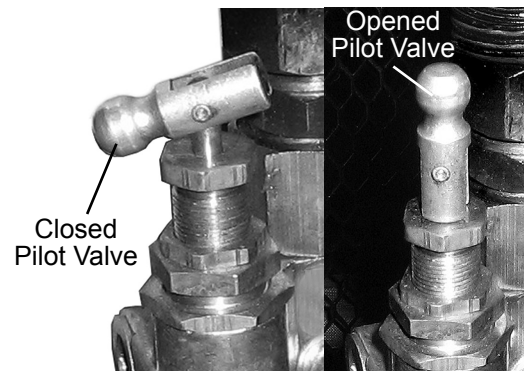
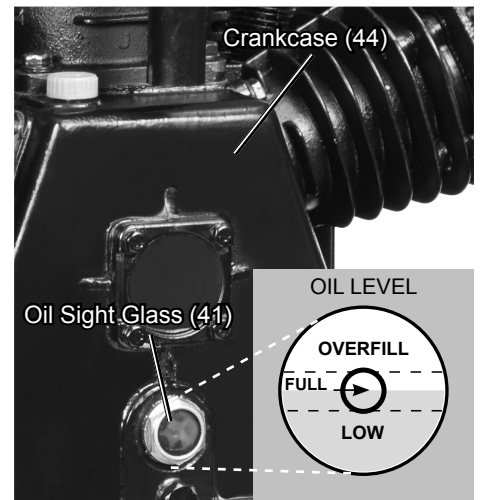

Mounting to a Truck Bed

SAFETY

1. Before mounting, if needed, reinforce the area with plywood or steel plating.
2. With assistance, move the compressor to the truck bed location and mark the floor of the truck bed through the holes in the compressor's feet. Check for any hidden wiring or cables and adjust the location for the holes as needed. Then, temporarily set the compressor aside.
3. Drill the four 1/2" diameter holes through the truck bed and any reinforcing materials.
4. Set the compressor back in place, and align the foot holes with the pre-drilled holes. Use four 1/2" diameter, bolts, washers and lock washers (all not included) to secure the compressor in place.

Assembly

To install the Muffler Assembly (8), fit the Connector into the Muffler Assembly and slide the assembly into the hole on the side of the First Stage Cylinder Head (5). Secure in place with the Wing Nut.

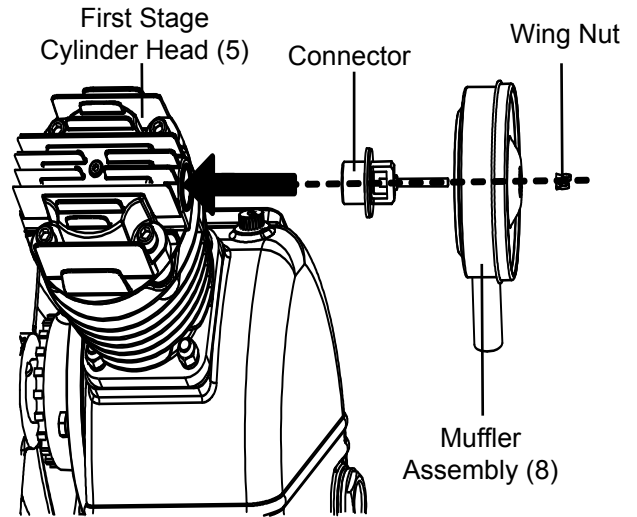

INSTALLATION

Breaking in the Compressor

1. Turn the Engine off.
Insert a male coupler (sold separately) into the female Quick Coupler and fully open all regulators and valves.
2. Check all fluid levels in the engine and pump.
3. Start the engine following the General Operating Instructions.
4. Let the unit run for 30 minutes. Air will expel freely through the Coupler.
5. Turn the Engine OFF.
6. Remove the male coupler.

OPERATION

Air Connection Setup

1. Connect a regulator valve, an inline shut off valve and a 1/4" NPT air hose to the Quick Coupler (all sold separately). The air hose must be long enough to reach the work area with enough extra length to allow free movement while working.

Note: An in-line shutoff ball valve is an important safety device because it controls the air supply even if the air hose is ruptured. The shutoff valve should be a ball valve because it can be closed quickly.

2. Depending on the tool that will be used with this compressor, incorporate additional components, such as an in-line oiler, a filter, or a dryer (all sold separately), as shown on Figure A on page 9. Consult air tool's manual for needed accessories. See Typical Air Line Setup charts on the following pages. This is a truckbed compressor, so use the portable setup as a model.

MAINTENANCE

Figure A: Portable Air Supply Setup

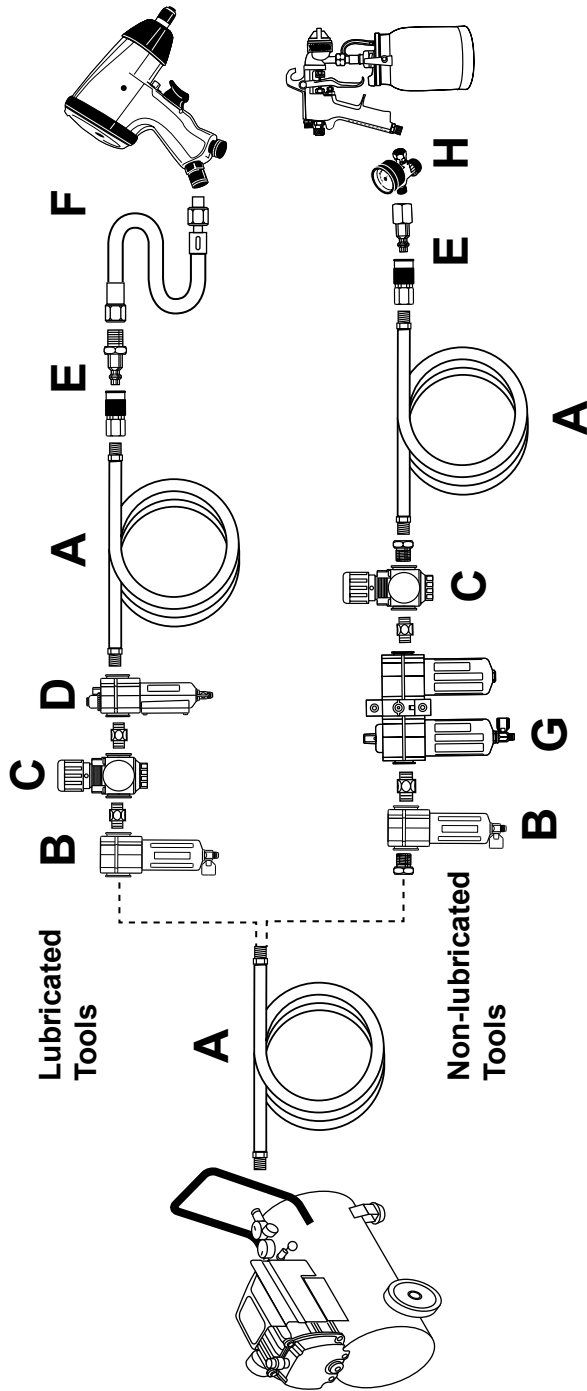

	Description	Function
A	Air Hose	Connects air to tool
B	Filter	Prevents dirt and condensation from damaging tool or workpiece
C	Regulator	Adjusts air pressure to tool
D	Lubricator (optional)	For air tool lubrication
E	Coupler and Plug	Provides quick connection and release
F	Leader Hose (optional)	Increases coupler life
G	Air Cleaner / Dryer (optional)	Prevents water vapor from damaging workpiece
H	Air Adjusting Valve (optional)	For fine tuning airflow at tool

Operating Instructions



Read the **ENTIRE IMPORTANT SAFETY INFORMATION** section at the beginning of this manual including all text under subheadings therein before set up or use of this product.

Using the Compressor

Inspect Compressor, engine, pump and equipment looking for damaged, loose, and missing parts before set up and starting. If any problems are found, do not use equipment until fixed properly.

Note: At the beginning of the day's first use of the Air Compressor, check for air leaks by applying soapy water to connections while the Air Compressor is pumping and after pressure cut-out. Look for air bubbles. If air bubbles are present at connections, tighten connections. Do not use the air compressor unless all connections are air tight. The extra air leaking out will cause the compressor to operate too often, increasing wear on the compressor.

Before starting the Compressor:



- Follow the Set Up Instructions in the equipment manual to prepare the equipment.
- Follow the Set Up Instructions in the Engine manual to prepare the engine.
- Inspect all components of the setup. Make sure all nuts and bolts are tight.
- Fill the Engine with the proper amount and type of both fuel and oil.
- Fill the Compressor Pump with compressor oil following the Maintenance Instructions in this manual.

To Start and Use the Compressor

- Close the Drain Valve (67) by turning the lever up so that it is perpendicular to the valve.
- Close the in-line Shutoff Valve between the compressor and the air hose.
- Open the Pilot Valve by rotating it to a vertical position.
- Open the Fuel Valve.

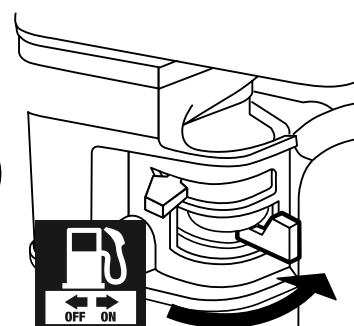
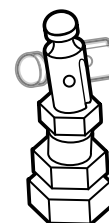
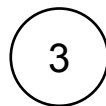
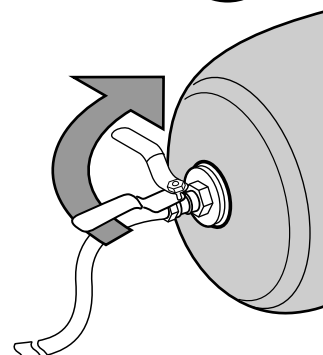
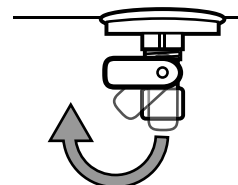
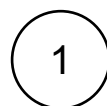

5. To start a cold engine, move the Choke to the START (start/closed) position.
To restart a warm engine, leave the Choke in the RUN position.

5

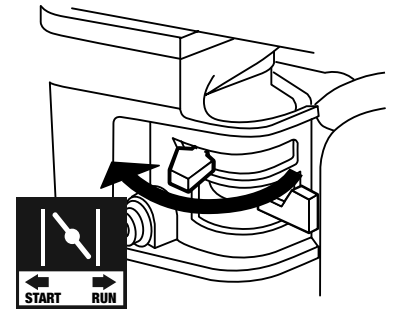

6. For MANUAL START

- a. Turn the Engine Switch to ON.

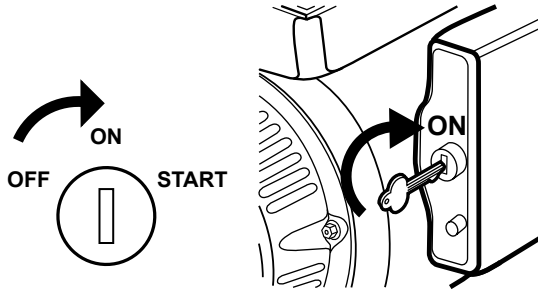

- b. Grip the Starter Handle of the Engine loosely and pull it slowly several times to allow the gasoline to flow into the Engine's carburetor. Then pull the Starter Handle gently until resistance is felt. Allow Cable to retract fully and then pull it quickly. Repeat until the engine starts. Note: Do not let the Starter Handle snap back against the engine. Hold it as it recoils so it doesn't hit the engine.

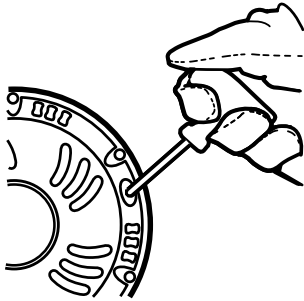

For ELECTRIC START

Turn the Engine Switch to START.

Note: To prolong starter life, use short starting cycles (5 seconds maximum). Then wait one minute before attempting to start again.

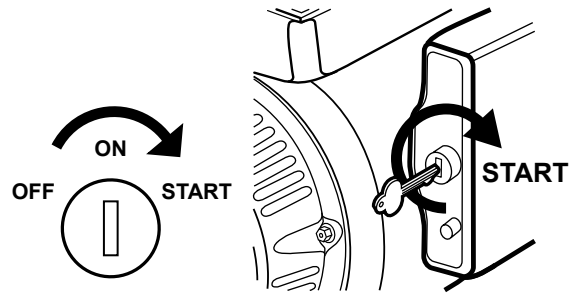

Note: If engine does not start, check engine oil. Engine will not start with low or no engine oil.

7. Allow the Engine to run for several seconds. Then, if the Choke lever is in the START position, move the Choke Lever very slowly to its RUN position.

Note: Moving the Choke Lever too fast could kill the engine.

7

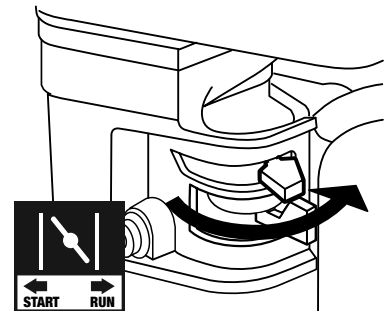

8. Close the Pilot Valve by rotating it to a horizontal position.

8

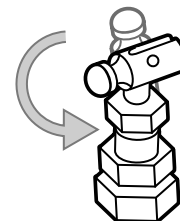

9. When the Gas Engine is started and running, the compressor Pump starts compressing air into the Air Tank. Open the in-line Shutoff Valve and adjust the Pressure Regulator (sold separately) so that the air output is enough to properly power the tool, but the output will not exceed the tool's maximum air pressure at any time. Turn the knob clockwise to increase the pressure and counterclockwise to decrease pressure. Adjust the pressure gradually, while checking the air output gauge to set the pressure.

9

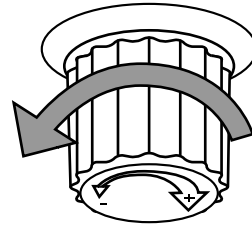

IMPORTANT: Allow the engine to run for five minutes with no load after each start-up so that the engine can stabilize.

Maintenance Break-in Period:

Breaking-in the engine will help to ensure proper equipment and engine operation.

The **maintenance** break-in period will last about 20 hours of use. After this period, change the engine oil.

Under normal operating conditions, subsequent maintenance follows the schedule explained in the MAINTENANCE AND SERVICING section.

Note: When maximum tank pressure is reached, the compressor automatically disengages, and the engine RPM drops down to idle speed. The engine remains at idle until Air Tank pressure falls to a preset level. The Gas Engine will then accelerate and air pressure once again begins to build up in the Air Tank.

Note: As long as the engine is running, the operation of the Air Compressor is automatic, controlled by an internal pressure switch.

IMPORTANT: The internal pressure switch is not user adjustable; **do not make changes to the air pressure settings of the internal pressure switch.** Any change to the automatic pressure levels may cause excess pressure to accumulate, causing a hazardous situation.

Note: Depressurization - If it is necessary to quickly *depressurize* the Compressor, turn OFF the engine. Then, pull on the ring on the tank Safety Valve to release stored air pressure.

10. Use the air tool as needed.

10

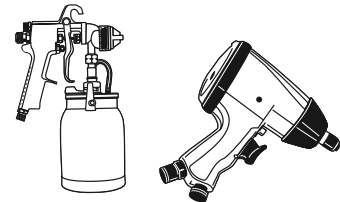

11. After the job is complete, turn OFF the engine.
To stop the engine in an emergency, turn the Engine Switch off.

Under normal conditions, use the following procedure:

- Turn the Engine Switch off.
- Close the Fuel Valve.

11

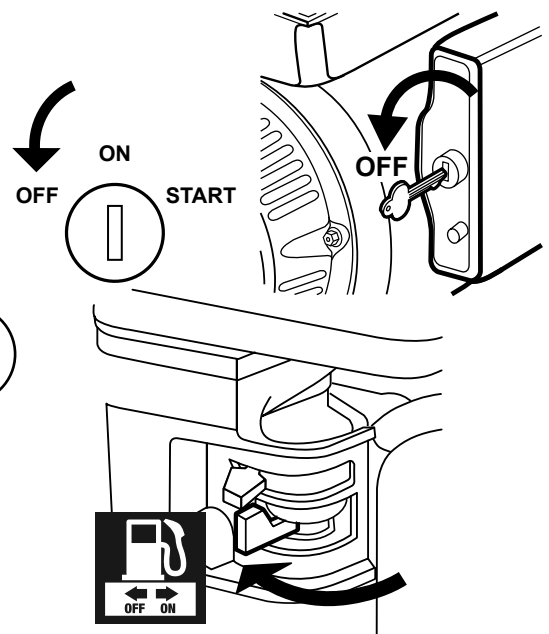

12. Close the in-line Shutoff Valve.

12

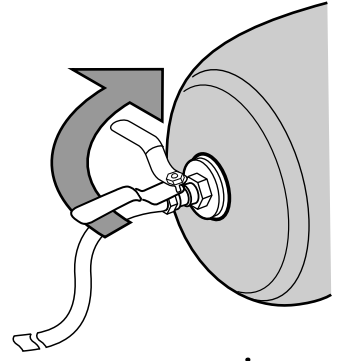

13. Bleed air from the tool then disconnect the tool.

13

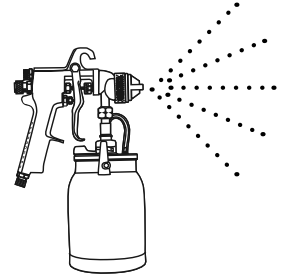

14. Open the Drain Valve at the bottom of the Tank, to release any built-up moisture and the internal tank pressure.

14

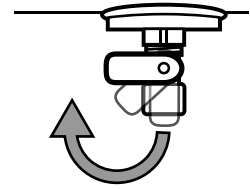

15. Clean, then store the Air Compressor inside a garage or another area that provides protection from the elements..

Emergency Depressurization

If it is necessary to quickly *depressurize* the Compressor, turn the Power Switch OFF. Then, pull on the ring on the Safety Valve to quickly release stored air pressure.

SAFETY

INSTALLATION

OPERATION

MAINTENANCE

Maintenance and Servicing



Procedures not specifically explained in this manual must be performed only by a qualified technician.

⚠️ WARNING

TO PREVENT SERIOUS INJURY FROM ACCIDENTAL OPERATION:

Turn the Power Switch of the equipment to its “OFF” position, release tank air pressure, wait for the engine to cool, and disconnect the spark plug cap before performing any inspection, maintenance, or cleaning procedures.

TO PREVENT SERIOUS INJURY FROM COMPRESSOR FAILURE:

Do not use damaged equipment. If abnormal noise or vibration occurs, have the problem corrected before further use.

Cleaning, Maintenance, and Lubrication

1. **BEFORE EACH USE**, inspect the general condition of the air compressor. Check for:
 - loose hardware,
 - misalignment or binding of moving parts,
 - cracked or broken parts,
 - damaged electrical wiring, and
 - any other condition that may affect its safe operation.
2. **AFTER USE**, wipe external surfaces of the compressor with a clean cloth.
3. **⚠️ WARNING! If the supply cord of this compressor is damaged, it must be replaced only by a qualified service technician.**

Compressor Pump Oil Maintenance

Check oil periodically for clarity. Replace oil if it appears milky or if debris is present, or every 6 months, or 100 hours of runtime, whichever comes first. In harsh environments such as high heat or high humidity, you will need to replace the oil more frequently.

Change the compressor oil after the first hour of use to remove any debris.

Adding Oil

1. The oil level should be at the center of the “full” level on the Oil Sight Glass, as shown above. Add oil as needed to maintain this level. Do not let the oil level go below the center dot (LOW as shown below) and do not overfill the oil so that it is above the center dot (OVERFILL as shown below) on the Oil Sight Glass.

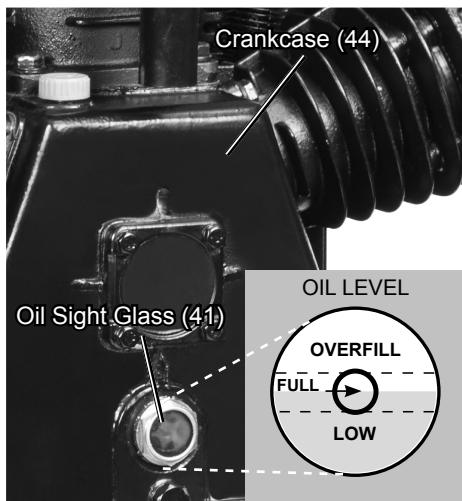

2. To add oil:
 - a. Remove the Oil Plug (46).

- b. Using a funnel to avoid spills, pour enough oil into the pump Crankcase to reach the “full” level in the Oil Sight Glass.
- c. Replace the Oil Plug.

Cold Weather Operation

Premium quality 30-weight, non-detergent air compressor oil (sold separately) is recommended for use with this compressor. Start compressor in heated area if outdoor temperatures drop below 32° F. If this is not practical, drain out the old pump oil and use L-PAB100-150 Non-detergent Air Compressor Oil in the pump crankcase instead whenever the compressor's temperature will fall below 40°. Do not use multi-viscosity oil (such as 10W-30), they leave carbon deposits on pump components and lead to accelerated failure. Heavy operation may require heavier viscosity oil.

3. If uncertain which oil to use for this compressor, please call Harbor Freight Tools customer service at 1-888-866-5797 for assistance.

WARNING! To prevent serious injury from burns: Do not add or change the oil while the compressor is in operation. Allow the compressor to cool before replacing oil.

Changing Oil

1. Place a container under the Drain Plug.
2. Remove the Oil Plug to allow air flow into the Pump.
3. Remove the Drain Plug, allowing the oil to drain into the container.
4. When the oil is completely drained from the Pump, replace the Drain Plug.
5. Fill the Pump with new compressor oil to the FULL level on the Oil Sight Glass.
6. Replace and tighten the Oil Plug.
7. Discard the old oil according to local, state and federal regulations.

Draining Moisture from the Tank

The Moisture Drain is located under the Tank. It must be used daily to release all trapped air and moisture from the Tank. Doing this will eliminate condensation and prevent tank corrosion.

1. Turn the Power Switch of the compressor off.
2. Place a collection pan under the Moisture Drain.
3. Open the Moisture Drain two or three turns ONLY.
4. When all the pressure and moisture is released, close the Moisture Drain.

Air Filter Maintenance

Check the Air Filter weekly to see if it needs replacement. If working in dirty environments, you may need to replace the filter more often. To replace the Air Filter:

1. Unthread the Wing Nut holding the Muffler Assembly in place.
2. Remove the Muffler Assembly.
3. Replace with a new Air Filter.
4. Secure in place with the Wing Nut.

Adjusting Belt Tension

SAFETY

1. Remove the Belt Guard Cover (97) and set it aside.

Deflection Distance

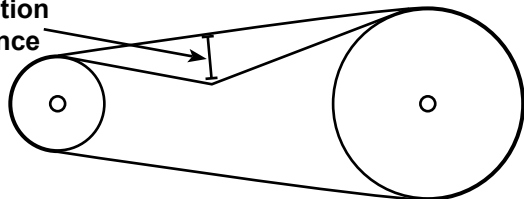

2. Press on the center of the longest span on each belt with moderate finger pressure (4-4.5 lb.). Then measure the deflection distance, the distance that the belt moved. The belt should deflect anywhere from 1/2" to 1".

INSTALLATION

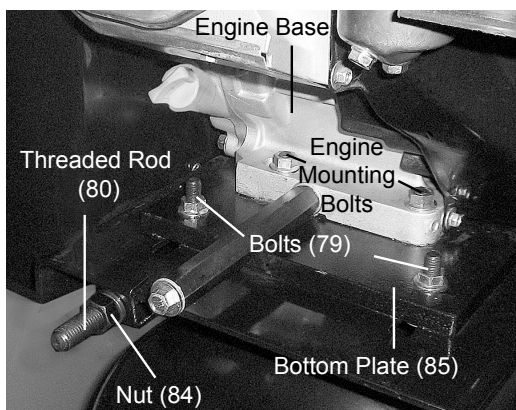

3. **If either belt deflects too much**, tighten belts by loosening the four Bolts (79) on the Bottom Plate (85) and moving the engine away from the other pulley slightly by turning the Nut (84) holding the Threaded Rod (80). Secure engine mounting bolts and retest tension. If either belt is too long to be properly tensioned, both belts must be replaced.
4. **If either belt deflects too little**, loosen belts by loosening the Bolts on the Bottom Plate and moving the engine towards the other pulley slightly by turning the Nut (84) on the Threaded Rod (80). Secure engine mounting bolts and retest tension.
5. Before use, replace belt cover.

OPERATION

Maintenance Schedule

Following are general guidelines for maintenance checks of the Air Compressor.

Note: The environment in which the compressor is used, and the frequency of use will affect how often you will need to check the Air Compressor components and perform maintenance procedures.

Daily:

- a. Make sure all nuts and bolts are tight.
- b. Drain moisture from air tank.
- c. Check for abnormal noise or vibration.
- d. Check for air leaks.*
- e. Wipe off any oil or dirt from the compressor.**

Weekly:

- a. Inspect Air Filter.

Monthly:

- a. Inspect Safety Valve.

* To check for air leaks, apply soapy water to joints while the Air Compressor is pressurized. Look for air bubbles.

** To clean the compressor surface, wipe with a damp cloth, using a mild detergent or mild solvent.

MAINTENANCE

Troubleshooting

Problem	Possible Causes	Likely Solutions
Engine will not start (Note: See engine manual for engine specific issues.)	COMPRESSOR SPECIFIC: 1. Pilot Valve closed. 2. Tank already pressurized.	COMPRESSOR SPECIFIC: 1. Open pilot valve before start procedure, close after unit is running. 2. Turn engine on. Compressor will turn on as needed when pressure reaches preset level.
Compressor overheats	1. Incorrect lubrication or not enough lubrication. 2. Worn parts.	1. Lubricate using recommended oil or grease according to directions. 2. Have qualified technician inspect internal mechanism and replace parts as needed.
Severe air leakage	1. Poor air outlet seal. 2. Loose cylinder/cylinder head. 3. Damaged valve or housing. 4. Dirty, worn or damaged valve.	1. Tighten or re-attach using thread seal tape. 2. Tighten cylinder/cylinder head assembly. If cylinder/cylinder head cannot tighten properly, internal parts may be misaligned. 3. Replace damaged components. 4. Clean or replace valve assembly.
Unit stalls	1. Low engine idle. 2. Severely clogged air filter. 3. Improper lubrication. 4. Defective pilot/unloader valve.	1. Qualified technician should increase idle to 2,000±100 RPM by adjusting pressure switch. 2. Replace air filter. 3. Check for proper oil level. 4. Replace pilot valve.
Excessive noise	1. Loose drive pulley or flywheel. 2. Misaligned pulleys. 3. Lack of oil in crankcase. 4. Worn connecting rod. 5. Worn wrist pin bushing. 6. Worn bearings. 7. Loose belts.	1. Loose pulleys are a common cause of "knocking". Tighten appropriate bolts. 2. Align pulleys with straightedge and secure in place. 3. Check for proper oil level. 4. Replace connecting rod. 5. Remove piston assembly and replace necessary parts. 6. Replace bearings and oil. 7. Check for proper belt tension.
Oil in the discharge air	1. Wrong type of oil or low-quality oil. 2. Overheating. 3. Restricted intake air. 4. Worn piston rings. 5. Excessive moisture in the tank.	1. Change oil. Check oil recommendations under EQUIPMENT SET UP, Equipment Oil Fill section of this manual. 2. See above Excessive Noise section. 3. Clean or replace air filter. 4. Replace piston rings. 5. Drain moisture from the tank daily.
Low discharge pressure	1. Air leaks. 2. Leaking valves. 3. Restricted air intake. 4. Blown gaskets. 5. Slipping belts.	1. Listen for escaping air. Apply soap solution to all fittings and connections. Bubbles will appear at points of leakage. Tighten or replace leaking fittings or connections. 2. Remove head and inspect for valve breakage, weak valves, scored valve plate, etc. Replace defective parts and reassemble. Replace head gasket each time the head is removed. 3. Clean or replace air filter element. 4. Replace and gaskets proven faulty on inspection. 5. Tighten Belts (See monthly maintenance.)



Follow all safety precautions whenever diagnosing or servicing the equipment or engine.

SAFETY

INSTALLATION

OPERATION

MAINTENANCE

Parts List and Diagram

Parts List

SAFETY

INSTALLATION

OPERATION

MAINTENANCE

Part	Description	Qty
1	Exhaust Elbow	3
2	Spring Washer	8
3	Bolts M10×50	8
4	Tube	1
5	First Stage Cylinder Head (Iron)	2
6	Safety Valve	1
7	T-Type Exhaust Tee	1
8	Muffler	2
8-1	Muffler Aluminium Joint	1
8-2	Muffler Gasket	1
8-3	Muffler Seat	1
8-4	Air Filter	1
8-5	Muffler Cover	1
8-6	Flat Washer	1
8-7	Wing Nut M6	1
9	Cylinder Head Sealing Gasket	2
10	Valve Plate Assembly	2
10-1	Bolt M5×12	2
10-2	Spring Washer	2
10-3	Lift Limiter	1
10-4	Exhaust Valve Piece	1
10-5	Valve Plate	1
10-6	Intake Valve Slice	1
10-7	Cylindrical Pin Ø3×8	2
10-8	Spring Sheet	1
11	Valve Plate Seal	2
12	Bolts M10×25	12
13	Spring Washer	25
14	Cylinder	2
15	Cylinder Seal	3
16	Piston Ring Ø90	2
17	Hole Circlip Ø20	4
18	Piston Pin Ø20×80	2
19	Piston (Aluminum)	2
20	Connecting Rod (Oblique)	1
21	Connecting Rod (Straight)	1
22	Tube	1

Part	Description	Qty
23	Bolts M8×50	4
24	Spring Washer	4
25	Second Stage Cylinder Head	1
26	Cylinder Head Gasket	1
27	Valve Plate	2
28	Valve Plate Aluminum Seal	1
29	Valves	2
30	Valve Plate Seal	1
31	Cylinder	1
32	Piston Ring	1
33	Hole Circlip	2
34	Piston (Iron)	1
35	Piston Pin	1
36	Connecting Rod	1
37	Bolts M6×20	4
38	Spring Washer	4
39	Small Square Back Cover	1
40	Back Cover Gasket	1
41	Oil Sight Glass	1
42	Oil Sight Gasket	1
43	Drain Plug	1
44	Crankcase	1
45	Oil Plug Seal	1
46	Oil Plug	1
47	Bearing	1
48	Shaft Circlips Ø30	1
49	Shoulder Ring	1
50	Crankshaft	1
51	Woodruff Key	1
52	Bearing	1
53	Oil Seal	1
54	Front Cover Gasket	1
55	Front Cover	1
56	Breathing Gasket	1
57	Connecting Rod (Iron)	1
58	Breathing	1
59	Spring Washer	6
60	Bolt M8×25	6
61	Belt Pulley	1
62	Pulley Retaining Ring	1

Part	Description	Qty
63	Bolt M10×35	1
64	Exhaust Tube	1
65	Air Outlet	1
66	Tank	1
67	Drain Valve	1
68	Nut M10	12
69	Flat Washer	12
70	Bolt M10×35	4
71	Combination Valve	1
72	Elbow	1
73	Unloading Tube	1
74	Throttle Push Rod	1
75	Safety Valve	1
76	Tank Pressure Gauge	1
77	Copper Tee	1
78	Wiring Stake	2
79	Bolt M10×35	4
80	Threaded Rod	1
81	Tense Card	1
82	Flat Washer	1
83	Spring Washer	1
84	Nut M12	1
85	Bottom Plate	1
86	Socket Cap Screw	4
87	Gasoline Engine	1
88	Gasoline Engine Pulley	1
89	Pulley Retainer Ring	1
90	Spring Washer	1
91	Bolt 3/8"×1-1/2	1
92	V-Belt	2
93	Belt Guard Frame	1
94	Flat Washer	13
95	Spring Washer	13
96	Bolt M8×20	13
97	Belt Guard Cover	1
98	Belt Guard Bracket	1
99	Bolt M6×16	1
100	Standard Spring Washer	1
101	Flat Washer	1
102	Nut	1
103	Belt Guard Bracket	1

Record Product's Serial Number Here: _____

Note: If product has no serial number, record month and year of purchase instead.

Note: Some parts are listed and shown for illustration purposes only, and are not available individually as replacement parts.

Assembly Diagram

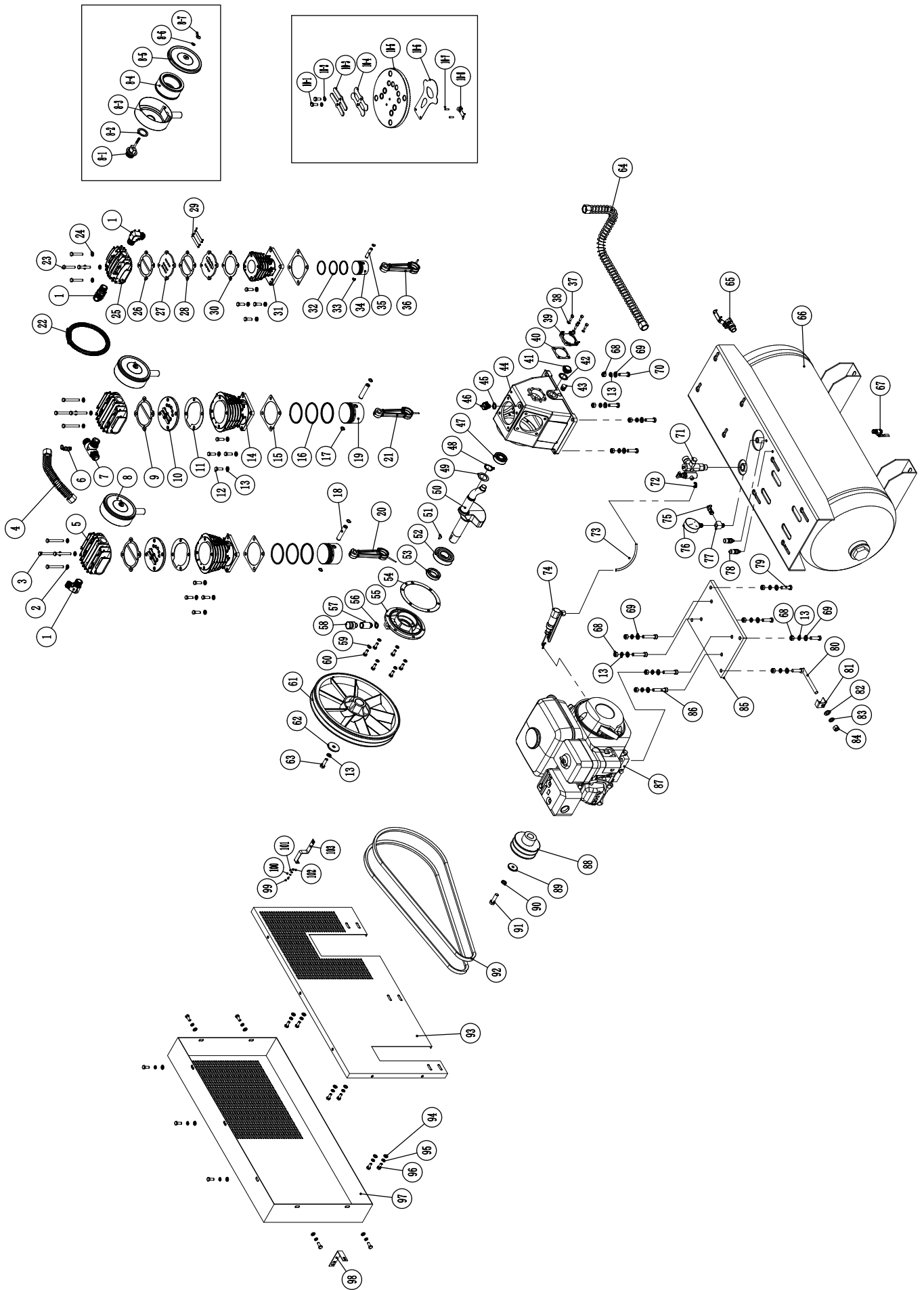

SAFETY

INSTALLATION

OPERATION

MAINTENANCE

PLEASE READ THE FOLLOWING CAREFULLY

THE MANUFACTURER AND/OR DISTRIBUTOR HAS PROVIDED THE PARTS LIST AND ASSEMBLY DIAGRAM IN THIS MANUAL AS A REFERENCE TOOL ONLY. NEITHER THE MANUFACTURER OR DISTRIBUTOR MAKES ANY REPRESENTATION OR WARRANTY OF ANY KIND TO THE BUYER THAT HE OR SHE IS QUALIFIED TO MAKE ANY REPAIRS TO THE PRODUCT, OR THAT HE OR SHE IS QUALIFIED TO REPLACE ANY PARTS OF THE PRODUCT. IN FACT, THE MANUFACTURER AND/OR DISTRIBUTOR EXPRESSLY STATES THAT ALL REPAIRS AND PARTS REPLACEMENTS SHOULD BE UNDERTAKEN BY CERTIFIED AND LICENSED TECHNICIANS, AND NOT BY THE BUYER. THE BUYER ASSUMES ALL RISK AND LIABILITY ARISING OUT OF HIS OR HER REPAIRS TO THE ORIGINAL PRODUCT OR REPLACEMENT PARTS THERETO, OR ARISING OUT OF HIS OR HER INSTALLATION OF REPLACEMENT PARTS THERETO.

Limited 90 Day Warranty

Harbor Freight Tools Harbor Freight Tools Harbor Freight Tools Harbor Freight Tools Harbor Freight Tools Co. makes every effort to assure that its products meet high quality and durability standards, and warrants to the original purchaser that this product is free from defects in materials and workmanship for the period of 90 days from the date of purchase. This warranty does not apply to damage due directly or indirectly, to misuse, abuse, negligence or accidents, repairs or alterations outside our facilities, criminal activity, improper installation, normal wear and tear, or to lack of maintenance. We shall in no event be liable for death, injuries to persons or property, or for incidental, contingent, special or consequential damages arising from the use of our product. Some states do not allow the exclusion or limitation of incidental or consequential damages, so the above limitation of exclusion may not apply to you. THIS WARRANTY IS EXPRESSLY IN LIEU OF ALL OTHER WARRANTIES, EXPRESS OR IMPLIED, INCLUDING THE WARRANTIES OF MERCHANTABILITY AND FITNESS.

To take advantage of this warranty, the product or part must be returned to us with transportation charges prepaid. Proof of purchase date and an explanation of the complaint must accompany the merchandise. If our inspection verifies the defect, we will either repair or replace the product at our election or we may elect to refund the purchase price if we cannot readily and quickly provide you with a replacement. We will return repaired products at our expense, but if we determine there is no defect, or that the defect resulted from causes not within the scope of our warranty, then you must bear the cost of returning the product.

This warranty gives you specific legal rights and you may also have other rights which vary from state to state.

CENTRAL PNEUMATIC®

3491 Mission Oaks Blvd. • PO Box 6009 • Camarillo, CA 93011 • 1-888-866-5797

Owner's Manual & Safety Instructions

Save This Manual Keep this manual for the safety warnings and precautions, assembly, operating, inspection, maintenance and cleaning procedures. Write the product's serial number in the back of the manual near the assembly diagram (or month and year of purchase if product has no number). Keep this manual and the receipt in a safe and dry place for future reference.

REV 17a

PREDATOR[®] E N G I N E S

420cc Horizontal Engine

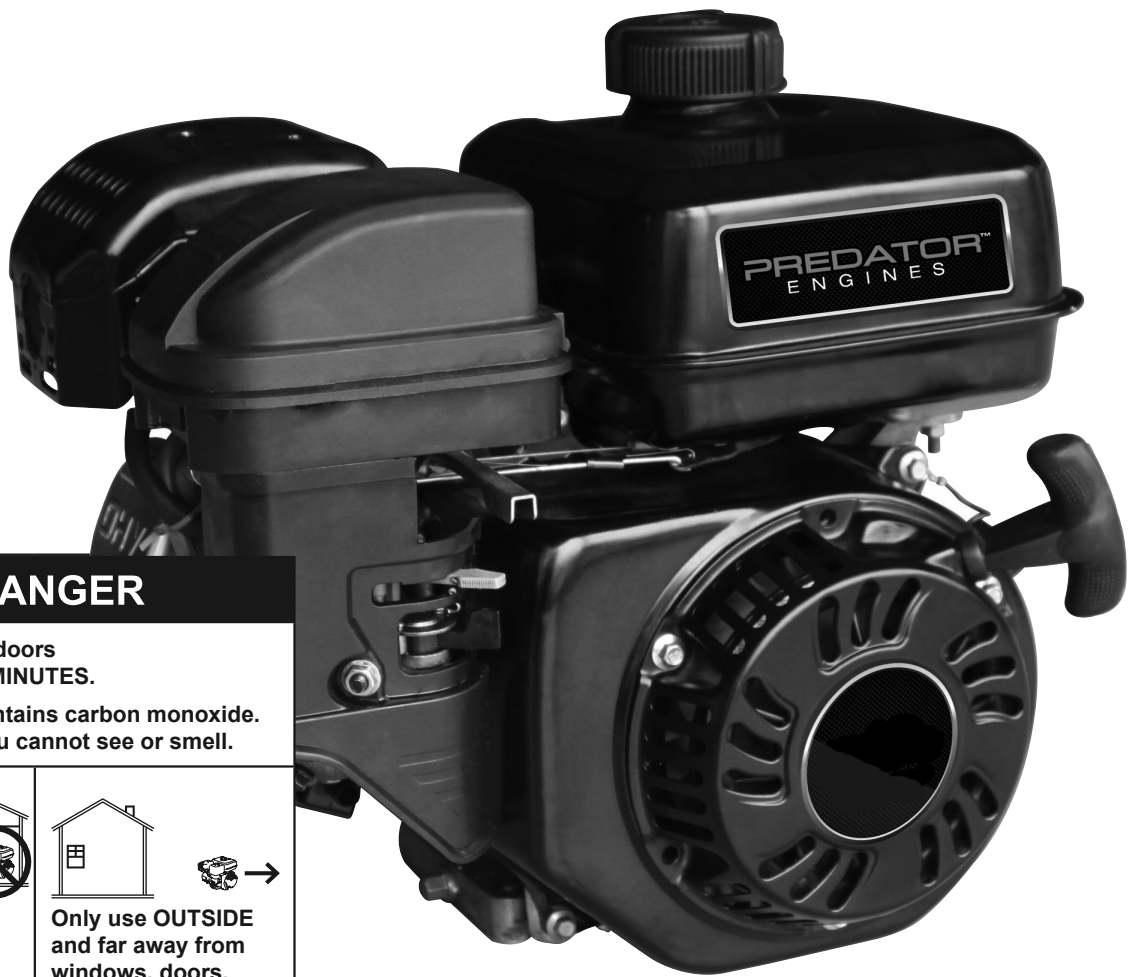

⚠ DANGER

Using an engine indoors
CAN KILL YOU IN MINUTES.

Engine exhaust contains carbon monoxide.
This is a poison you cannot see or smell.



NEVER use inside
a home or garage,
EVEN IF doors and
windows are open.

Only use **OUTSIDE**
and far away from
windows, doors,
and vents.

Visit our website at: <http://www.harborfreight.com>
Email our technical support at: predator@harborfreight.com
Email our engine support at: predator@harborfreight.com

**ENGINE FOR
62913**

When unpacking, make sure that the product is intact and undamaged. If any parts are missing or broken, please call 1-888-866-5797 as soon as possible.

⚠ WARNING

**Read this material before using this product.
Failure to do so can result in serious injury.
SAVE THIS MANUAL.**

Copyright © 2015 by Harbor Freight Tools®. All rights reserved.
No portion of this manual or any artwork contained herein may be reproduced in any shape or form without the express written consent of Harbor Freight Tools. Diagrams within this manual may not be drawn proportionally. Due to continuing improvements, actual product may differ slightly from the product described herein. Tools required for assembly and service may not be included.

Table of Contents

Specifications	2	Maintenance	14
Safety	3	Troubleshooting	18
Setup	6	Warranties	20
Operation	9	Parts Lists and Diagrams	22





Specifications

Displacement		420cc
Engine Type		Horizontal Single Cylinder 4-stroke
Cooling System		Forced air cooled
Fuel	Type	87+ octane stabilizer-treated unleaded gasoline
	Capacity	1.25 Gallon
Engine Oil	Type SAE	10W-30 above 32° F 5W30 at 32° F or below
	Capacity	1 Quart
Run Time @ 50% Load with full tank		3 hr.
Sound Level at 3 feet		92 dB
Bore x Stroke		90 mm x 66 mm
Compression Ratio		8.1:1
Rotation viewed from PTO (power takeoff - the output shaft)		Counterclockwise
Spark Plug	Type	BOSCH® F7TC Torch® F7TC
	Gap	0.0275" - 0.0314"
Valve Clearance	Intake	0.0039" - 0.0059"
	Exhaust	0.0039" - 0.0059"
Speed	Idle	2000± 100 RPM
Shaft	Shaft	Ø1" x 3.48"
	Keyway	1/4"x 3.48"
	End Tapped	3/8"- 24UNF



The emissions control system for this Engine is warranted for standards set by the U.S. Environmental Protection Agency and by the California Air Resources Board (also known as CARB). For warranty information, refer to the last pages of this manual.



PREDATOR[®]

E N G I N E S

WARNING SYMBOLS AND DEFINITIONS	
	This is the safety alert symbol. It is used to alert you to potential personal injury hazards. Obey all safety messages that follow this symbol to avoid possible injury or death.
	Indicates a hazardous situation which, if not avoided, will result in death or serious injury.
	Indicates a hazardous situation which, if not avoided, could result in death or serious injury.
	Indicates a hazardous situation which, if not avoided, could result in minor or moderate injury.
	Addresses practices not related to personal injury.

Symbol Definitions

Symbol	Property or Statement
RPM	Revolutions Per Minute
HP	Horsepower
	WARNING marking concerning Risk of Eye Injury. Wear ANSI-approved safety goggles with side shields.
	Read the manual before set-up and/or use.
	WARNING marking concerning Risk of Hearing Loss. Wear hearing protection.

Symbol	Property or Statement
	WARNING marking concerning Risk of Respiratory Injury. Operate engine OUTSIDE and far away from windows, doors, and vents.
	WARNING marking concerning Risk of Fire while handling fuel. Do not smoke while handling fuel.
	WARNING marking concerning Risk of Fire. Do not refuel while operating. Keep flammable objects away from engine.

IMPORTANT SAFETY INSTRUCTIONS

 **WARNING! Read all instructions.**
Failure to follow all instructions listed below may result in fire, serious injury and/or DEATH.
 The warnings and precautions discussed in this manual cannot cover all possible conditions and situations that may occur. It must be understood by the operator that common sense and caution are factors which cannot be built into this product, but must be supplied by the operator.

SAVE THESE INSTRUCTIONS

Set up Precautions

1. Gasoline fuel and fumes are flammable, and potentially explosive. Use proper fuel storage and handling procedures. Do not store fuel or other flammable materials nearby.
2. Have multiple ABC class fire extinguishers nearby.
3. Operation of this equipment may create sparks that can start fires around dry vegetation. A spark arrestor may be required. The operator should contact local fire agencies for laws or regulations relating to fire prevention requirements.
4. Set up and use only on a flat, level, well-ventilated surface.
5. Wear ANSI-approved safety goggles, heavy-duty work gloves, and dust mask/respirator during set up.
6. Use only lubricants and fuel recommended in the Specifications chart of this manual.

Operating Precautions

1.  **CARBON MONOXIDE HAZARD**
Using an engine indoors CAN KILL YOU IN MINUTES.
Engine exhaust contains carbon monoxide. This is a poison you cannot see or smell.

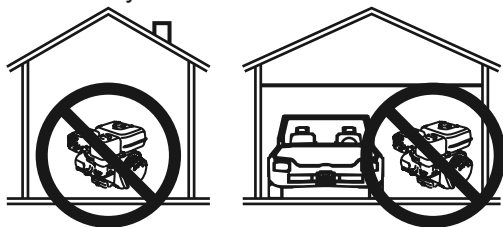

NEVER use inside a home or garage, EVEN IF doors and windows are open.

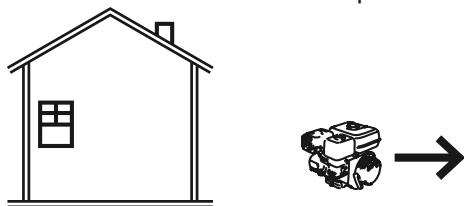

Only use OUTSIDE and far away from windows, doors, and vents.

2. Keep children away from the equipment, especially while it is operating.
3. Keep all spectators at least six feet from the Engine during operation.
4. Fire Hazard! Do not fill fuel tank while engine is running. Do not operate if gasoline has been spilled. Clean spilled gasoline before starting engine. Do not operate near pilot light or open flame.
5. Do not touch engine during use. Let engine cool down after use.
6. Never store fuel or other flammable materials near the engine.
7. Only use a suitable means of transport and lifting devices with sufficient weight bearing capacity when transporting the engine.
8. Secure the engine on transport vehicles to prevent it from rolling, slipping, and tilting.
9. Industrial applications must follow OSHA requirements.
10. Do not leave the engine unattended when it is running. Turn off the engine (and remove safety keys, if available) before leaving the work area.
11. The engine can produce high noise levels. Prolonged exposure to noise levels above 85 dBA is hazardous to hearing. Wear ear protection when operating the engine or when working nearby while it is operating.
12. Wear ANSI-approved safety glasses and hearing protection during use.
13. People with pacemakers should consult their physician(s) before use. Electromagnetic fields in close proximity to a heart pacemaker could cause pacemaker interference or pacemaker failure. Caution is necessary when near the engine's magneto or recoil starter.
14. Use only accessories that are recommended by Harbor Freight Tools for your model. Accessories that may be suitable for one piece of equipment may become hazardous when used on another piece of equipment.
15. Do not operate in explosive atmospheres, such as in the presence of flammable liquids, gases, or dust. Gasoline-powered engines may ignite the dust or fumes.
16. Stay alert, watch what you are doing and use common sense when operating this engine. Do not use while tired or under the influence of drugs, alcohol or medication.
17. Dress properly. Do not wear loose clothing or jewelry. Keep hair, clothing and gloves away from moving parts. Loose clothes, jewelry or long hair can be caught in moving parts.
18. Parts, especially exhaust system components, get very hot during use. Stay clear of hot parts.
19. Do not cover the engine during operation.
20. Keep the engine and surrounding area clean at all times.
21. Do not smoke, or allow sparks, flames, or other sources of ignition around the equipment, especially when refuelling.

Operating Precautions (cont.)

22. Use the equipment, accessories, etc., in accordance with these instructions and in the manner intended for the particular type of equipment, taking into account the working conditions and the work to be performed. Use of the equipment for operations different from those intended could result in a hazardous situation.
23. Do not operate the equipment with known leaks in the engine's fuel system.
24. **WARNING:** This product contains or, when used, produces a chemical known to the State of California to cause cancer and birth defects or other reproductive harm. (California Health & Safety Code § 25249.5, *et seq.*)
25. When spills of fuel or oil occur, they must be cleaned up immediately. Dispose of fluids and cleaning materials as per any local, state, or federal codes and regulations. Store oil rags in a bottom-ventilated, covered, metal container.
26. Keep hands and feet away from moving parts. Do not reach over or across equipment while operating.
27. Before use, check for misalignment or binding of moving parts, breakage of parts, and any other condition that may affect the equipment's operation. **If damaged, have the equipment serviced before using.** Many accidents are caused by poorly maintained equipment.
28. Use the correct equipment for the application. Do not modify the equipment and do not use the equipment for a purpose for which it is not intended.

Service Precautions

1. **Before service, maintenance, or cleaning:**
 - a. Turn the engine switch to its "OFF" position.
 - b. Allow the engine to completely cool.
 - c. Then, remove the spark plug cap from the spark plug.
2. Keep all safety guards in place and in proper working order. Safety guards include muffler, air cleaner, mechanical guards, and heat shields, among other guards.
3. **Do not alter or adjust any part of the equipment or its engine that is sealed by the manufacturer or distributor. Only a qualified service technician may adjust parts that may increase or decrease governed engine speed.**
4. Wear ANSI-approved safety goggles, heavy-duty work gloves, and dust mask/respirator during service.
5. Maintain labels and nameplates on the equipment. These carry important information. If unreadable or missing, contact Harbor Freight Tools for a replacement.
6. Have the equipment serviced by a qualified repair person using only identical replacement parts. This will ensure that the safety of the equipment is maintained. Do not attempt any service or maintenance procedures not explained in this manual or any procedures that you are uncertain about your ability to perform safely or correctly.
7. Store equipment out of the reach of children.
8. Follow scheduled engine and equipment maintenance.

Refueling:

1. Do not refill the fuel tank while the engine is running or hot.
2. Do not smoke, or allow sparks, flames, or other sources of ignition around the equipment, especially when refuelling.
3. **Do not fill fuel tank to the top.** Leave a little room for the fuel to expand as needed.
4. Refuel in a well-ventilated area only.
5. Wipe up any spilled fuel and allow excess to evaporate before starting engine. **To prevent FIRE, do not start the engine while the smell of fuel hangs in the air.**

Battery Service:

1. Servicing of batteries are to be performed or supervised by personnel knowledgeable of batteries and the required precautions. Keep unauthorized personnel away from batteries.
2. When replacing batteries, use the following type batteries: **12 volt, 300 CCA, 36 Ah** battery, sealed, lead-acid type
3. **CAUTION** – Do not dispose of battery or batteries in a fire. The battery is capable of exploding.
4. **CAUTION** – Do not open or mutilate the battery. Released electrolyte has been know to be harmful to the skin and eyes and to be toxic.
5. **CAUTION** – A battery presents a risk of high short circuit current. The following precautions are to be observed when working on batteries:
 - a. Remove watches, rings, or other metal objects,
 - b. Use tools with insulated handles, and
 - c. Do not lay tools or metal parts on top of batteries.



SAVE THESE INSTRUCTIONS.

Set Up



Read the **ENTIRE IMPORTANT SAFETY INFORMATION** section at the beginning of this manual including all text under subheadings therein before set up or use of this product.

⚠️ WARNING

TO PREVENT SERIOUS INJURY:

Operate only with proper spark arrestor installed.



Operation of this equipment may create sparks that can start fires around dry vegetation. A spark arrestor may be required.

The operator should contact local fire agencies for laws or regulations relating to fire prevention requirements.

WARNING! DO NOT INSTALL THIS ENGINE ON A VEHICLE.

WARNING! INSTALL THIS ENGINE ACCORDING TO EQUIPMENT INSTRUCTIONS BEFORE USE.

WARNING! If you do not connect a battery to the positive battery cable, wrap its terminal securely with electrical tape (sold separately).

Battery Setup Instructions

1. Place a **fully charged, lead-acid 12 volt, 300 CCA, 36 Ah** battery (not included) in a stable, flat location near the engine.
2. Only use cables sized to match their length according to the following chart:

Cable Gauge (lower gauge numbers mean thicker cables)	Maximum Cable Length
(6)	5'
(4)	7'
(2)	12'

4. Attach the negative cable to the negative battery terminal.

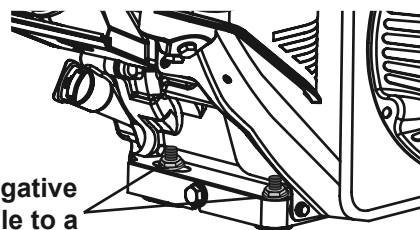

Connect Negative Battery Cable to a Mounting Bolt

5. Connect the negative cable securely to one of the engine **mounting bolts**, as shown in the diagram above. Connect cable securely to prevent disconnection and short circuits.
6. Coat the terminals and cable ends with a corrosion-preventive coating.

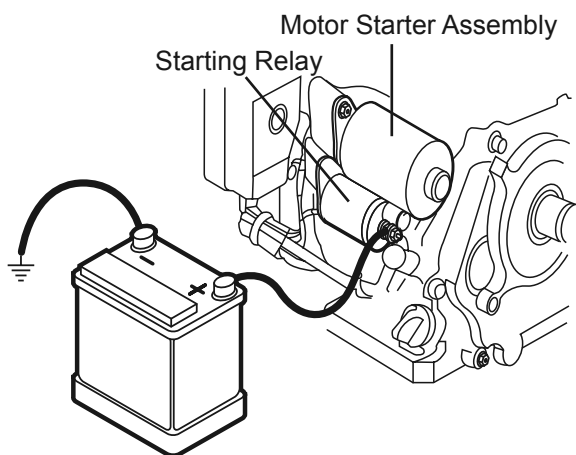

3. Attach the positive cable from the positive battery terminal to the Positive Terminal on the starter solenoid (**uncovered terminal**), shown above. Connect cable securely to prevent disconnection and short circuits.

Components and Controls

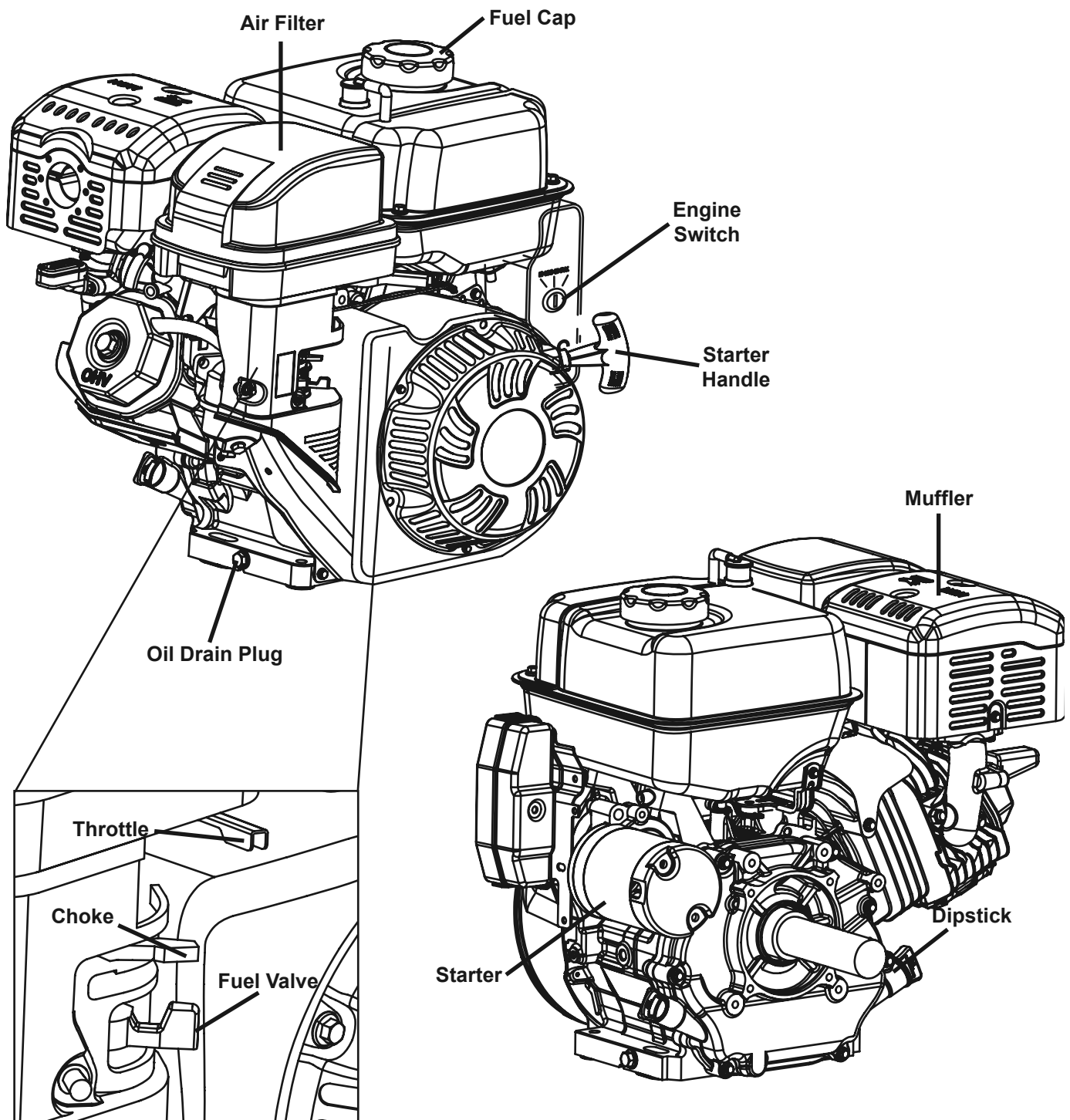

SAFETY

SETUP

OPERATION

MAINTENANCE

High Altitude Operation Above 3000 feet

SAFETY

⚠ WARNING! TO PREVENT SERIOUS INJURY FROM FIRE:

Follow instructions in a well-ventilated area away from ignition sources.

If the engine is hot from use, shut the engine off and wait for it to cool before proceeding. Do not smoke.

NOTICE: Warranty void if necessary adjustments are not made for high altitude use.

At high altitudes, the engine's carburetor, governor (if so equipped), and any other parts that control the fuel-air ratio will need to be adjusted by a qualified mechanic to allow efficient high-altitude use and to prevent damage to the engine and any other devices used with this product. The fuel system on this engine may be influenced by operation at higher altitudes. Proper operation can be ensured by installing an altitude kit at altitudes higher than 3000 ft. above sea level. At elevations above 8000 ft, the engine may experience decreased performance, even with the proper main jet. Operating this engine without the proper altitude kit installed may increase the engine's emissions and decrease fuel economy and performance. The kit should be installed by a qualified mechanic.

1. Turn off the engine.
2. Close the fuel valve.
3. Place a bowl under the fuel cup to catch any spilled fuel.

CAUTION! Carburetor bowl may have gas in it which will leak upon removing the bolt.

4. Unthread the bolt holding the fuel cup.
5. Remove the bolt, Bolt Seal, fuel cup, Fuel Cup Seal and Main Jet from the body of the carburetor assembly. A carburetor screwdriver (not included) is needed to remove and install the Main Jet.

Note: The mixing tube is held in place by the Main Jet and might fall out when it is removed. If it falls out, replace it in the same orientation before replacing the Main Jet.

6. Replace the Main Jet with the replacement Main Jet needed for your altitude range (part 1a or 2a).

Note: The Fuel Cup Seal and Bolt Seal may be damaged during removal and should be replaced with the new ones from the kit.

7. Replace the Fuel Cup Seal (4a), fuel cup, Bolt Seal (3a), and bolt. Tighten in place.

NOTICE: Do not cross thread bolt when tightening.

Finger tighten first and then use a wrench to make sure the bolt is properly threaded.

8. Wipe up any spilled fuel and allow excess to evaporate before starting engine. To prevent FIRE, do not start the engine while the smell of fuel hangs in the air.

SETUP

OPERATION

MAINTENANCE

High Altitude Kit Parts List - A

Part	Description	Qty
1a	Main Jet 3000-6000 ft.	1
2a	Main Jet 6000-8000 ft.	1
3a	Bolt Seal	1
4a	Fuel Cup Seal	1

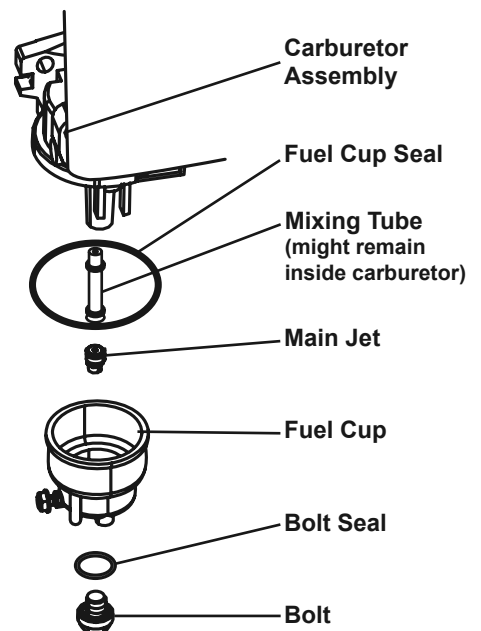

Operation



Read the **ENTIRE IMPORTANT SAFETY INFORMATION** section at the beginning of this manual including all text under subheadings therein before set up or use of this product.

Pre-Start Checks

Inspect engine and equipment looking for damaged, loose, and missing parts before set up and starting. If any problems are found, do not use equipment until fixed properly.

Checking and Filling Engine Oil

NOTICE: Your Warranty is VOID if the engine's crankcase is not properly filled with oil before each use. Before each use, check the oil level. Engine will not start with low or no engine oil.

1. Make sure the engine is stopped and is level.
2. Close the Fuel Valve.
3. Clean the top of the Dipstick and the area around it. Remove the Dipstick by turning it counterclockwise, and wipe it off with a clean, lint free rag.

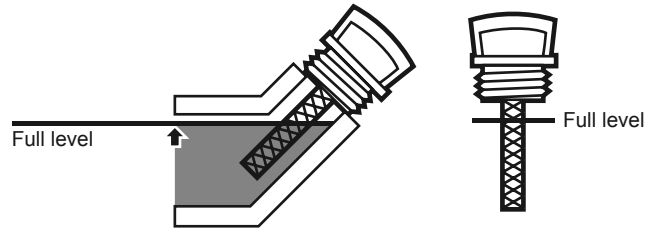

4. Reinsert the Dipstick without threading it in and remove it to check the oil level. The oil level should be up to the full level as shown above.
5. If the oil level is at or below the low mark add the appropriate type of oil until the oil level is at the proper level. SAE 10W-30 oil is recommended for general use. (The SAE Viscosity Grade chart on page 15 in the Maintenance section shows other viscosities to use in different average temperatures.)
6. Thread the dipstick back in clockwise.

NOTICE: Do not run the engine with too little oil. Engine will shut off if engine oil level is too low.

Checking and Filling Fuel



WARNING! TO PREVENT SERIOUS INJURY FROM FIRE:

Fill the fuel tank in a well-ventilated area away from ignition sources. If the engine is hot from use, shut the engine off and wait for it to cool before adding fuel. Do not smoke.

1. Clean the Fuel Cap and the area around it.
2. Unscrew and remove the Fuel Cap.
3. Remove the Strainer and remove any dirt and debris. Then replace the Strainer.

Note: Do not use gasoline containing more than 10% ethanol (E10). Do not use E85 ethanol. Add fuel stabilizer to the gasoline or the Warranty is VOID.

Note: Do not use gasoline that has been stored in a metal fuel container or a dirty fuel container. It can cause particles to enter the carburetor, affecting engine performance and/or causing damage.

4. If needed, fill the Fuel Tank to about 1 inch under the fill neck of the Fuel Tank with 87 octane or higher unleaded gasoline that has been treated with a fuel stabilizer additive. Follow fuel stabilizer manufacturer's recommendations for use.
5. Then replace the Fuel Cap.
6. Wipe up any spilled fuel and allow excess to evaporate before starting engine. To prevent FIRE, do not start the engine while the smell of fuel hangs in the air.

Starting the Engine

Before Starting the Engine



Before starting the engine:

- a. Follow the Set Up Instructions in the equipment manual to prepare the equipment.
- b. Inspect the equipment and engine.
- c. Fill the engine with the proper amount and type of both stabilizer-treated unleaded gasoline and oil.
- d. Read the Equipment Operation section in the equipment manual.

Manual Start

SAFETY

1. To start a cold engine, move the Choke to the START position.
To restart a warm engine, leave the Choke in the RUN position.

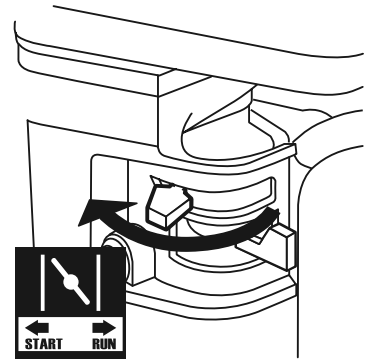

SETUP

2. Open the Fuel Valve.

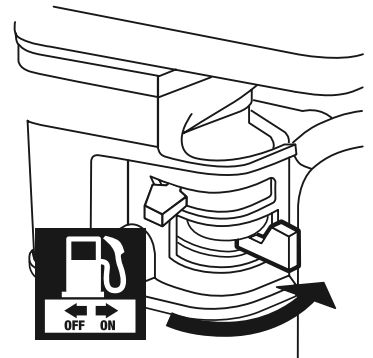

3. Slide the Throttle or Speed Control Lever to 1/3 away from the SLOW position (the "turtle").

Note: Some tools have a Speed Control Lever located elsewhere on the tool which functions the same as the Throttle. Use the Speed Control Lever in place of the Throttle when the tool is so equipped.

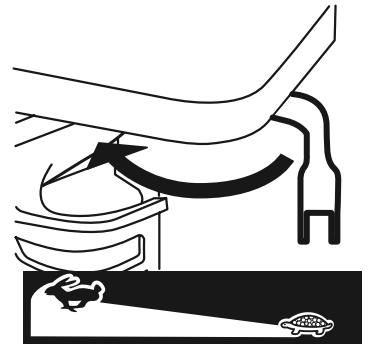
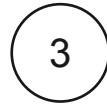

OPERATION

4. Turn the Engine Switch to START.

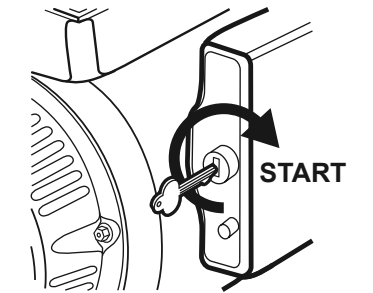
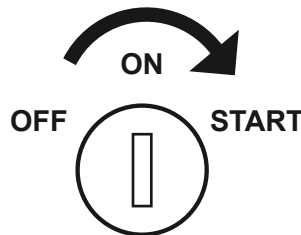

Note: If engine does not start, check engine oil level. Engine will not start with low or no engine oil.

5. Grip the Starter Handle of the Engine loosely and pull it slowly several times to allow the gasoline to flow into the Engine's carburetor. Then pull the Starter Handle gently until resistance is felt. Allow Cable to retract fully and then pull it quickly. Repeat until the engine starts.

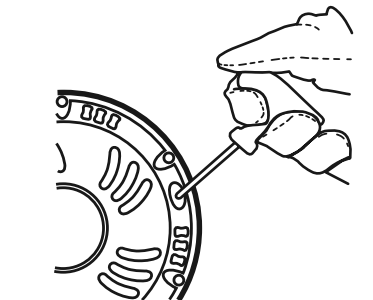

MAINTENANCE

Note: Do not let the Starter Handle snap back against the engine. Hold it as it recoils so it doesn't hit the engine.

6. Allow the Engine to run for several seconds.
Then, if the Choke lever is in the START position,
move the Choke Lever very slowly to its RUN position.

Note: Moving the Choke Lever too fast could stall the engine.

IMPORTANT: Allow the engine to run at no load for five minutes after each start-up so that the engine can stabilize.

7. Adjust the Throttle as needed.

6

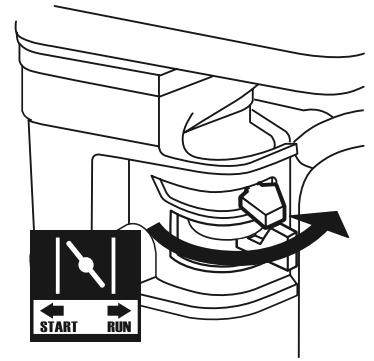

SAFETY

SETUP

OPERATION

MAINTENANCE

PREDATOR[®]
E N G I N E S

Electric Start (if equipped)

SAFETY

1. To start a cold engine, move the Choke to the START position.
To restart a warm engine, leave the Choke in the RUN position.

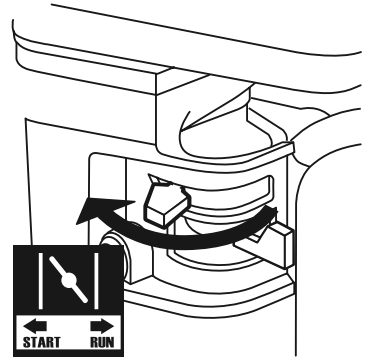

SETUP

2. Open the Fuel Valve.

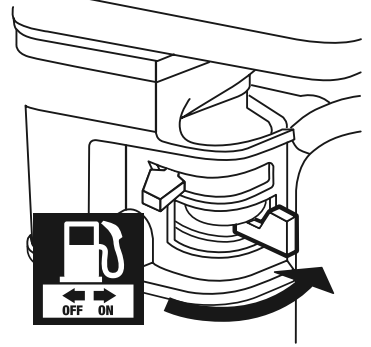

3. Slide the Throttle or Speed Control Lever to 1/3 away from the SLOW position (the "turtle").

Note: Some tools have a Speed Control Lever located elsewhere on the tool which functions the same as the Throttle. Use the Speed Control Lever in place of the Throttle when the tool is so equipped.



OPERATION

4. Turn the Engine Switch to START.

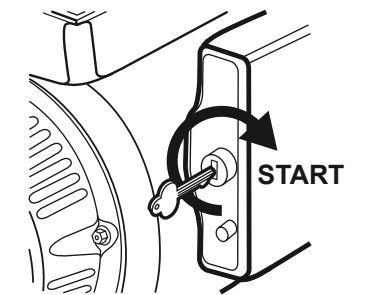
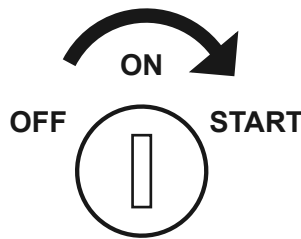

Note: If engine does not start, check engine oil level. Engine will not start with low or no engine oil.

5. Allow the Engine to run for several seconds. Then, if the Choke lever is in the START position, move the Choke Lever very slowly to its RUN position.

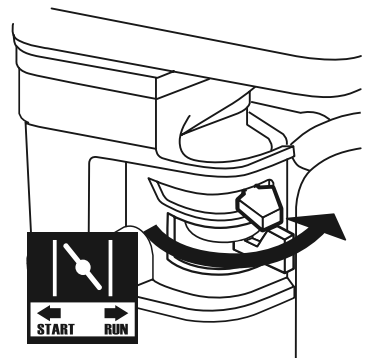

Note: Moving the Choke Lever too fast could stall the engine.

IMPORTANT: Allow the engine to run at no load for five minutes with no load after each start-up so that the engine can stabilize.

6. Adjust the Throttle as needed.

MAINTENANCE

Break-in Period:

- a. Breaking-in the engine will help to ensure proper equipment and engine operation.
- b. The operational break-in period will last about 3 hours of use. During this period:
 - Do not apply a heavy load to the equipment.
 - Do not operate the engine at its maximum speed.
- c. The maintenance break-in period will last about 20 hours of use.
 - Change the engine oil after this period.

Under normal operating conditions subsequent maintenance follows the schedule explained in the MAINTENANCE section.

Stopping the Engine

1. To stop the engine in an emergency, turn the Engine Switch off.
2. Under normal conditions, use the following procedure:
 - a. Slide the Throttle or Speed Control Lever to SLOW (the "turtle").
 - b. Turn the Engine Switch off.
 - c. Close the Fuel Valve.

NOTICE

See Long-Term Storage on page 17 for complete storage instructions.

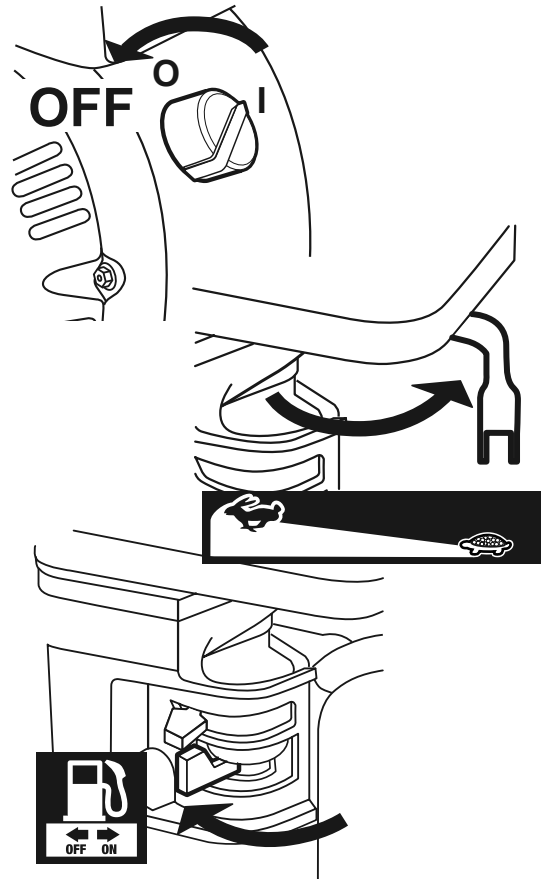

PREDATOR[®]

ENGINES

Maintenance

⚠️ WARNING

TO PREVENT SERIOUS INJURY FROM ACCIDENTAL STARTING:

Turn the Power Switch of the equipment to its "OFF" position, wait for the engine to cool, and disconnect the spark plug cap before performing any inspection, maintenance, or cleaning procedures.

TO PREVENT SERIOUS INJURY FROM EQUIPMENT FAILURE:

Do not use damaged equipment. If abnormal noise, vibration, or excess smoking occurs, have the problem corrected before further use.

Follow all service instructions in this manual. The engine may fail critically if not serviced properly.



Many maintenance procedures, including any not detailed in this manual, will need to be performed by a qualified technician for safety. If you have any doubts about your ability to safely service the equipment or engine, have a qualified technician service the equipment instead.

Cleaning, Maintenance, and Lubrication Schedule

Note: This maintenance schedule is intended solely as a general guide. If performance decreases or if equipment operates unusually, check systems immediately. The maintenance needs of each piece of equipment will differ depending on factors such as duty cycle, temperature, air quality, fuel quality, and other factors.

Note: The following procedures are in addition to the regular checks and maintenance explained as part of the regular operation of the engine and equipment.

Procedure	Before Each Use	Monthly or every 20 hr. of use	Every 3 mo. or 50 hr. of use	Every 6 mo. or 100 hr. of use	Yearly or every 300 hr. of use	Every 2 Years
Brush off outside of engine	✓	✓	✓	✓	✓	✓
Check engine oil level	✓	✓	✓	✓	✓	✓
Check air cleaner			✓	✓	✓	✓
Check sediment cup				✓	✓	✓
Change engine oil		✓		✓	✓	✓
Clean air filter			✓*	✓	✓	✓
Check and clean spark plug				✓	✓	✓
1. Check/adjust idle speed 2. Check/adjust valve clearance 3. Clean fuel tank, strainer and carburetor 4. Clean carbon build-up from combustion chamber					✓**	✓**
Replace fuel line if necessary						✓**

*Service more frequently when used in dusty areas.

**These items should be serviced by a qualified technician.

Checking and Filling Fuel



⚠️WARNING! TO PREVENT SERIOUS INJURY FROM FIRE:

Fill the fuel tank in a well-ventilated area away from ignition sources. If the engine is hot from use, shut the engine off and wait for it to cool before adding fuel. Do not smoke.

1. Clean the Fuel Cap and the area around it.
2. Unscrew and remove the Fuel Cap.
3. Remove the Strainer and remove any dirt and debris. Then replace the Strainer.

Note: Do not use gasoline containing more than 10% ethanol (E10). Do not use E85 ethanol. Add fuel stabilizer to the gasoline or the Warranty is VOID.

Note: Do not use gasoline that has been stored in a metal fuel container or a dirty fuel container. It can cause particles to enter the carburetor, affecting engine performance and/or causing damage.

4. If needed, fill the Fuel Tank to about 1 inch under the fill neck of the Fuel Tank with 87 octane or higher unleaded gasoline that has been treated with a fuel stabilizer additive. Follow fuel stabilizer manufacturer's recommendations for use.
5. Then replace the Fuel Cap.
6. Wipe up any spilled fuel and allow excess to evaporate before starting engine. To prevent FIRE, do not start the engine while the smell of fuel hangs in the air.

Engine Oil Change

⚠️CAUTION! Oil is very hot during operation and can cause burns. Wait for engine to cool before changing oil.

1. Make sure the engine is stopped and is level.
2. Close the Fuel Valve.
3. Place a drain pan (not included) underneath the crankcase's drain plug.
4. Remove the drain plug and, if possible, tilt the crankcase slightly to help drain the oil out. Recycle used oil.
5. Replace the drain plug and tighten it.
6. Clean the top of the Dipstick and the area around it. Remove the Dipstick by turning it counterclockwise, and wipe it off with a clean, lint free rag.

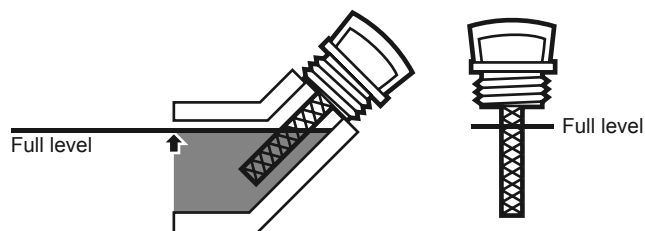

7. Add the appropriate type of oil until the oil level is at the full level. SAE 10W-30 oil is recommended for general use. The SAE Viscosity Grade chart shows other viscosities to use in different average temperatures.

SAE Viscosity Grades

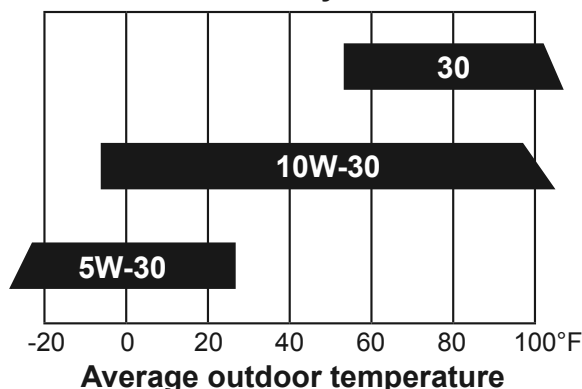

8. Thread the dipstick back in clockwise.

NOTICE: Do not run the engine with too little oil. Engine will not start with low or no engine oil.

Air Filter Maintenance

1. Remove the Air Cleaner Cover and the air filter(s) and check for dirt. Clean as described below.
2. **Cleaning:**
 - For paper filters:
To prevent injury from dust and debris, wear ANSI-approved safety goggles, NIOSH-approved dust mask/respirator, and heavy-duty work gloves. In a well-ventilated area away from bystanders, use pressurized air to blow dust out of the filter.
 - For foam filters:
Wash the filter in warm water and mild detergent several times. Rinse. Squeeze out excess water and allow it to dry completely. Soak the filter in lightweight oil briefly, then squeeze out the excess oil.
3. Install the cleaned filter(s). Secure the Air Cleaner Cover before use.

Spark plug Maintenance

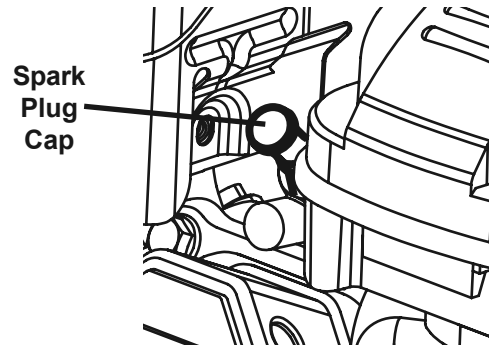

1. Disconnect spark plug cap from end of plug. Clean out debris from around spark plug.
2. Using a spark plug wrench, remove the spark plug.
3. Inspect the spark plug:
If the electrode is oily, clean it using a clean, dry rag. If the electrode has deposits on it, polish it using emery paper. If the white insulator is cracked or chipped, the spark plug needs to be replaced.

Recommended Spark Plugs	
BOSCH®	F7TC
TORCH®	F7TC

NOTICE: Using an incorrect spark plug may damage the engine.

4. When installing a new spark plug, adjust the plug's gap to the specification on the Specifications chart. Do not pry against the electrode, the spark plug can be damaged.
5. Install the new spark plug or the cleaned spark plug into the engine.
 - **Gasket-style:**
Finger-tighten until the gasket contacts the cylinder head, then tighten about 1/2-2/3 turn more.
 - **Non-gasket-style:**
Finger-tighten until the plug contacts the cylinder head, then tighten about 1/16 turn more.

NOTICE: Tighten the spark plug properly. **If loose**, the spark plug will cause the engine to overheat.

If overtightened, the threads in the engine block will be damaged.

6. Apply dielectric spark plug boot protector (not included) to the end of the spark plug and reattach the cap securely.

Long-Term Storage

When the equipment is to remain idle for longer than 20 days, prepare the Engine for storage as follows:

1. **CLEANING:**

Wait for Engine to cool, then clean Engine with dry cloth. **NOTICE: Do not clean using water.** The water will gradually enter the Engine and cause rust damage. Apply a thin coat of rust preventive oil to all metal parts.

2. **FUEL:**

To protect the fuel tank during storage, fill the tank with gasoline that has been treated with a fuel stabilizer additive. Follow fuel stabilizer manufacturer's recommendations for use. Refer to *Checking and Filling Fuel* on page 15.



⚠️ WARNING! TO PREVENT SERIOUS INJURY FROM FIRE:

Fill tank in a well-ventilated area away from ignition sources. If the engine is hot from use, shut the engine off and wait for it to cool before adding fuel. Do not smoke.

3. **LUBRICATION:**

- a. Change engine oil.
- b. Clean out area around spark plug.
Remove spark plug and pour one tablespoon of engine oil into cylinder through spark plug hole.

- c. Replace spark plug, but leave spark plug cap disconnected.
- d. Pull Starter Handle to distribute oil in cylinder. Stop after one or two revolutions when you feel the piston start the compression stroke (when you start to feel resistance).

4. **BATTERY:**

Disconnect battery cables (if equipped). Recharge batteries monthly while in storage.

5. **STORAGE AREA:**

Cover and store in a dry, level, well-ventilated area out of reach of children. Storage area should also be away from ignition sources, such as water heaters, clothes dryers, and furnaces.

NOTICE: During extended storage periods the Engine must be started every 3 months and allowed to run for 15–20 minutes or the Warranty is VOID.

6. **AFTER STORAGE:**

Before starting the Engine during or after storage, keep in mind that untreated gasoline will deteriorate quickly. Drain the fuel tank and change to fresh fuel if untreated gasoline has been sitting for a month, if treated gasoline has been sitting beyond the fuel stabilizer's recommended time period, or if the Engine does not start.

Troubleshooting

SAFETY

SETUP

OPERATION

MAINTENANCE

Problem	Possible Causes	Probable Solutions
Engine will not start	FUEL RELATED: <ol style="list-style-type: none"> No fuel in tank or fuel valve closed. Choke not in START position, cold engine. Gasoline with more than 10% ethanol used. (E15, E20, E85, etc.) Low quality or deteriorated, old gasoline. Carburetor not primed. Dirty fuel passageways. Carburetor needle stuck. Fuel can be smelled in the air. Too much fuel in chamber. This can be caused by the carburetor needle sticking. Clogged Fuel Filter. 	FUEL RELATED: <ol style="list-style-type: none"> Fill fuel tank with fresh 87+ octane stabilizer-treated unleaded gasoline and open fuel valve. Do not use gasoline with more than 10% ethanol (E15, E20, E85, etc.). Move Choke to START position. Clean out ethanol rich gasoline from fuel system. Replace components damaged by ethanol. Use fresh 87+ octane stabilizer-treated unleaded gasoline only. Do not use gasoline with more than 10% ethanol (E15, E20, E85, etc.). Use fresh 87+ octane stabilizer-treated unleaded gasoline. Do not use gasoline with more than 10% ethanol (E15, E20, E85, etc.). Pull on Starter Handle to prime. Clean out passageways using fuel additive. Heavy deposits may require further cleaning. Gently tap side of carburetor float chamber with screwdriver handle. Turn Choke to RUN position. Remove spark plug and pull the start handle several times to air out the chamber. Reinstall spark plug and set Choke to START position. Replace Fuel Filter.
	IGNITION (SPARK) RELATED: <ol style="list-style-type: none"> Spark plug cap not connected securely. Spark plug electrode wet or dirty. Incorrect spark plug gap. Spark plug cap broken. Circuit breaker tripped. Incorrect spark timing or faulty ignition system. 	IGNITION (SPARK) RELATED: <ol style="list-style-type: none"> Connect spark plug cap properly. Clean spark plug. Correct spark plug gap. Replace spark plug cap. Reset circuit breaker. Check wiring and starter motor if breaker continues to trip. Have qualified technician diagnose/repair ignition system.
	COMPRESSION RELATED: <ol style="list-style-type: none"> Cylinder not lubricated. Problem after long storage periods. Loose or broken spark plug. (Hissing noise will occur when trying to start.) Loose cylinder head or damaged head gasket. (Hissing noise will occur when trying to start.) Engine valves or tappets mis-adjusted or stuck. 	COMPRESSION RELATED: <ol style="list-style-type: none"> Pour tablespoon of oil into spark plug hole. Crank engine a few times and try to start again. Tighten spark plug. If that does not work, replace spark plug. If problem persists, may have head gasket problem, see #3. Tighten head. If that does not remedy problem, replace head gasket. Have qualified technician adjust/repair valves and tappets.
	ENGINE OIL RELATED: <ol style="list-style-type: none"> Low engine oil. Engine mounted on slope, triggering low oil shutdown. 	ENGINE OIL RELATED: <ol style="list-style-type: none"> Fill engine oil to proper level. Check engine oil before EVERY use. Operate engine on level surface. Check engine oil level.



Follow all safety precautions whenever diagnosing or servicing the equipment or engine.

Problem	Possible Causes	Probable Solutions
Engine misfires	<ol style="list-style-type: none"> 1. Spark plug cap loose. 2. Incorrect spark plug gap or damaged spark plug. 3. Defective spark plug cap. 4. Old or low quality gasoline. 5. Incorrect compression. 	<ol style="list-style-type: none"> 1. Check cap and wire connections. 2. Re-gap or replace spark plug. 3. Replace spark plug cap. 4. Use only fresh 87+ octane stabilizer-treated unleaded gasoline. Do not use gasoline with more than 10% ethanol (E15, E20, E85, etc.). 5. Diagnose and repair compression. (Use Engine will not start: COMPRESSION RELATED section.)
Engine stops suddenly	<ol style="list-style-type: none"> 1. Fuel tank empty or full of impure or low quality gasoline. 2. Low oil shutdown. 3. Defective fuel tank cap creating vacuum, preventing proper fuel flow. 4. Faulty magneto. 5. Disconnected or improperly connected spark plug cap. 	<ol style="list-style-type: none"> 1. Fill fuel tank with fresh 87+ octane stabilizer-treated unleaded gasoline. Do not use gasoline with more than 10% ethanol (E15, E20, E85, etc.). 2. Fill engine oil to proper level. Check engine oil before EVERY use. 3. Test/replace fuel tank cap. 4. Have qualified technician service magneto. 5. Secure spark plug cap.
Engine stops when under heavy load	<ol style="list-style-type: none"> 1. Dirty air filter 2. Engine running cold. 	<ol style="list-style-type: none"> 1. Clean element. 2. Allow engine to warm up prior to operating equipment.
Engine knocks	<ol style="list-style-type: none"> 1. Old or low quality gasoline. 2. Engine overloaded. 3. Incorrect spark timing, deposit buildup, worn engine, or other mechanical problems. 	<ol style="list-style-type: none"> 1. Fill fuel tank with fresh 87+ octane stabilizer-treated unleaded gasoline. Do not use gasoline with more than 10% ethanol (E15, E20, E85, etc.). 2. Do not exceed equipment's load rating. 3. Have qualified technician diagnose and service engine.
Engine backfires	<ol style="list-style-type: none"> 1. Impure or low quality gasoline. 2. Engine too cold. 3. Intake valve stuck or overheated engine. 4. Incorrect timing. 	<ol style="list-style-type: none"> 1. Fill fuel tank with fresh 87+ octane stabilizer-treated unleaded gasoline. Do not use gasoline with more than 10% ethanol (E15, E20, E85, etc.). 2. Use cold weather fuel and oil additives to prevent backfiring. 3. Have qualified technician diagnose and service engine. 4. Check engine timing.
After sudden impact, engine will run, but equipment will not operate	Shaft key or other shear pin broken by impact to disconnect engine and limit damage.	Have qualified technician check and replace broken shaft key or other shear pins.
After sudden impact, engine will run, but equipment will not operate	Shaft key or other shear pin broken by impact to disconnect engine and limit damage.	Have qualified technician check and replace broken shaft key or other shear pins.



Follow all safety precautions whenever diagnosing or servicing the equipment or engine.

Limited 90 Day Warranty (Retail)

Harbor Freight Tools Co. makes every effort to assure that its products meet high quality and durability standards, and warrants to the original purchaser that this product is free from defects in materials and workmanship for the period of 90 days from the date of purchase. This warranty does not apply to damage due directly or indirectly, to misuse, abuse, negligence or accidents, repairs or alterations outside our facilities, criminal activity, improper installation, normal wear and tear, or to lack of maintenance. We shall in no event be liable for death, injuries to persons or property, or for incidental, contingent, special or consequential damages arising from the use of our product. Some states do not allow the exclusion or limitation of incidental or consequential damages, so the above limitation of exclusion may not apply to you. THIS WARRANTY IS EXPRESSLY IN LIEU OF ALL OTHER WARRANTIES, EXPRESS OR IMPLIED, INCLUDING THE WARRANTIES OF MERCHANTABILITY AND FITNESS, EXCEPT FOR THE EMISSIONS CONTROL SYSTEM WARRANTY BELOW.

To take advantage of this warranty, the product or part must be returned to us with transportation charges prepaid. Proof of purchase date and an explanation of the complaint must accompany the merchandise. If our inspection verifies the defect, we will either repair or replace the product at our election or we may elect to refund the purchase price if we cannot readily and quickly provide you with a replacement. We will return repaired products at our expense, but if we determine there is no defect, or that the defect resulted from causes not within the scope of our warranty, then you must bear the cost of returning the product.

This warranty gives you specific legal rights and you may also have other rights which vary from state to state.

Emissions Control System Warranty

The California Air Resources Board and Harbor Freight Tools (HFT) are pleased to explain the emissions control system warranty on your 2017 Small Off-Road Engine. In California, new equipment that uses small off-road engines must be designed, built, and equipped to meet the State's stringent anti-smog standards. HFT must warrant that the emissions control system on your engine will be free from defects in material and workmanship for two (2) years, provided there has been no abuse, neglect, or improper maintenance of your engine. HFT also warrants that the emissions control system on your engine is designed, built, and equipped so that it conforms to the United States Environmental Protection Agency's (EPA) emissions requirements in effect at the time of manufacture.

Your emissions control system may include parts such as the carburetor or fuel-injection system, the ignition system, catalytic converter, fuel lines, fuel caps, valves, canisters, vapor hoses, clamps, connectors, and other emissions-related assemblies.

Where a warrantable condition exists, HFT will repair or replace, at our option, your engine if at no cost to you, including diagnosis, parts and labor.

MANUFACTURER'S WARRANTY COVERAGE

This emissions control system is warranted for two years. If any emission-related part on your engine is defective, the part will be repaired or replaced by HFT.

OWNER'S WARRANTY RESPONSIBILITIES

As the engine owner, you are responsible for the performance of the required maintenance listed in your Owner's Manual.

As the engine owner, you should however be aware that HFT may deny you warranty coverage if your engine or a part has failed due to abuse (including failure to follow the fuel use instructions contained in this manual), neglect, improper maintenance, or unapproved modifications.

You are responsible for contacting HFT as soon as the problem exists in order to obtain warranty repair or replacement, by doing either of the following: (a) contact HFT product support at 1-888-866-5797 or predator@harborfreight.com; or (b) bring the to your nearest Harbor Freight Tools retail store. The nearest Harbor Freight Tools retail store can be found on the internet at <http://www.harborfreight.com>. The warranty repairs or replacement should be completed in a reasonable amount of time, not to exceed 30 days. If you have a question regarding your warranty coverage, you should contact HFT product support at 1-888-866-5797 or predator@harborfreight.com.

GENERAL EMISSIONS WARRANTY COVERAGE

- a) The warranty period begins on the date the engine or equipment is delivered to an ultimate purchaser. The warranty period is two years.
- b) HFT warrants to the initial owner and each subsequent owner that the engine is:
1. Designed, built, and equipped so as to conform with all applicable regulations adopted by the Air Resources Board; and
 2. Free from defects in materials and workmanship that causes the failure of a warranted part for a period of two years.
- c) The warranty on emissions-related parts is as follows:
1. Any warranted part that is not scheduled for replacement as required maintenance in the written instructions provided, is warranted for the warranty period stated above. If any such part fails during the period of warranty coverage, it will be repaired or replaced HFT. Any such part repaired or replaced under the warranty will be warranted for the remaining warranty period.
 2. Any warranted part that is scheduled only for regular inspection in the written instructions is warranted for the warranty period stated above. A statement in the written instructions to the effect of "repair or replace as necessary" does not reduce the period of warranty coverage. Any such part repaired or replaced under warranty will be warranted for the remaining warranty period.
 3. Any warranted part that is scheduled for replacement as required maintenance in the written instructions will be warranted for the period of time prior to the first scheduled replacement point for that part. If the part fails prior to the first scheduled replacement, the part will be repaired or replaced by HFT. Any such part repaired or replaced under warranty will be warranted for the remainder of the period prior to the first scheduled replacement point for the part.
 4. Repair or replacement of any warranted part under the warranty will be performed at no charge to the owner at a retail store or by HFT paying for shipping the product for repair.
 5. Notwithstanding the provisions herein, warranty services or repairs will be provided at all retail stores or by contacting HFT product support at 1-888-866-5797 or predator@harborfreight.com.
 6. The owner will not be charged for diagnostic labor that leads to the determination that a warranted part is in fact defective, provided that such diagnostic work is performed at a retail store.
 7. HFT is liable for damages to other engine components proximately caused by a failure under warranty of any warranted part.
 8. Throughout the emissions warranty period stated above, HFT will maintain a supply of warranted parts sufficient to meet the expected demand for such parts.
 9. Any replacement part may be used in the performance of any warranty maintenance or repairs and will be provided without charge to the owner. Such use will not reduce the warranty obligations of HFT.
 10. Add-on or modified parts that are not approved by HFT may not be used. The use of any non-exempted add-on or modified parts will be grounds for disallowing a warranty claim. HFT is not liable to warrant failures of warranted parts caused by the use of a non-exempted add-on or modified part.
- d) Emission Warranty Parts List.
- | | |
|--|---|
| 1. Fuel Metering System | 4. Catalyst System (if so equipped) |
| a. Carburetor and its internal parts (and/or pressure regulator or fuel injection system). | a. Exhaust pipe stud/exhaust manifold. |
| b. Fuel tank. | b. Thermal reactor. |
| c. Cold start enrichment system. | c. Catalytic converter (if so equipped). |
| d. Air/fuel ratio feedback and control system. | 5. Particulate Controls |
| 2. Air Induction System | a. Traps, filters, precipitators, and any other device used to capture particulate emissions. |
| a. Controlled hot air intake system. | 6. Miscellaneous Items Used in Above Systems |
| b. Intake manifold. | a. Vacuum, temperature and time sensitive valves and switches. |
| c. Air filter. | b. Hoses, belts, connectors, and assemblies. |
| 3. Ignition System | 7. Evaporative Emission Control System |
| a. Spark plugs. | a. Fuel tank. |
| b. Magneto ignition system. | b. Fuel caps, valves, canisters, filters, vapor hoses, clamps, connectors, belts, and assemblies. |
| c. Spark advance/retard system. | |

HFT provides with each product written instructions for the maintenance and use of the product by the owner

Parts List

SAFETY

SETUP

OPERATION

MAINTENANCE

Part	Description	Qty.
1	Flange Bolt	6
2	Cover Comp. Head	1
3	Head Cover Packing	1
4	Breather Tube	1
5	Flange Bolt, 10×80	4
6	Rotator Valve	2
7	Retainer Valve Spring	2
8	Locker Valve	4
9	Spring Valve	2
10	Seat Valve Spring	1
11	Seal Valve Stem	1
12	Exhaust Rocker Arm Ass'y.	1
13	Intake Rocker Arm Ass'y.	1
14	Locker	4
15	Valve Rocker Shaft	2
16	Stud Bolt	2
17	Spark Plug	1
18	Cylinder Head Comp	1
19	Gasket Cylinder	1
20	Dowel Pin	2
21	Valve Assy.	1
22	Push Rod	2
23	Lifter Valve	2
24	Drain Plug Bolt	2
25	Drain Plug Washer, 12Mm	2
26	Oil Seal Ø35×Ø52×7	2
27	Crankcase	1
28	Cable Cleat	1
29	Flange Bolt	1
30	Oil Level Switch	1
31	Flange Bolt, M6x12	2
32	Alert Unit Oil	1
33	Flange Bolt, M6x12	1
34	Piston Ring Set	1
35	Piston	1
36	Connecting Rod Ass'y	1
37	Piston Pin	1
38	Piston Pin Clip	2
39	Crankshaft Ass'y	1
40	Balancer Weight	1
41	Camshaft Ass'y	1
42	Ball Bearing 6202	2
43	Ball Bearing 6207	1
44	Dowel Pin Ø8×12	2
45	Governor Kit	1
46	Crankcase Cover Gasket	1
47	Crankcase Cover	1
48	Cap Ass'y	2
49	Flange Bolt 8X40	7
50	Shroud	1
51	Flange Bolt M6×12	1
52	Stud Bolt	2
53	Carburetor Packing	1
54	Carburetor Insulator	1
55	Insulator Packing	1
56	Carburetor Ass'y.	1

Part	Description	Qty.
57	Air Cleaner Packing	1
58	Flange Nut	2
59	Air Cleaner Ass'y	1
60	Air Cleaner Element Ass'y.	1
61	Cord Grommet	1
62	Stop Switch Holder	1
63	Ignition Coil Ass'y.	1
64	Flange Bolt	2
65	Flywheel Comp. (Sel-Lamp)	1
66	Fan Cooling	1
67	Starter Pulley	1
68	Nut Special, M16	1
69	Recoil Starter Comp.	1
70	Starter Ass'y.	1
71	Flange Bolt, M6x12	5
72	Oil Seal Ø8×Ø14×4	1
73	Governor Arm Shaft	1
74	Washer, 8×16×1.2	1
75	Lock Pin, 10mm	1
76	Control Ass'y.	1
77	Flange Bolt, M6×12	2
78	Cable Return Spring	1
79	Throttle Return Spring	1
80	Governor Rod	1
81	Governor Arm	1
82	Governor Arm Bolt	1
83	Flange Nut M6	1
84	Starter Motor	1
85	Bolt, Flange	2
86	Contacto Ass'y.	1
87	Bolt Washer	2
88	Charge Coil Ass'y.	1
89	Flange Bolt	2
90	Cord Clamper	1
91	Flange Bolt	1
92	Ex. Pipe Gasket	1
93	Nut 8mm	5
94	Ex. Pipe Comp.	1
95	Ex. Pipe Gasket	1
96	Muffler Ass'y.	1
97	Fuel Tank	1
98	Fuel Filler Cap Comp.	1
99	Fuel Tank Filter	1
100	Fuel Tank Gas Valve	1
101	Fuel Tank Joint Ass'y.	1
102	Rubber Washer	2
103	Flange Nut	2
104	Flange Bolt	2
105	Fuel Tube	1
106	Pipe Clip	2
107	Pipe	1
108	Pipe Clip	1
115	Key	1
116	Cable Tie	1
117	Cable Tie	1
118	Electric Starting Control Box	1

Assembly Diagram

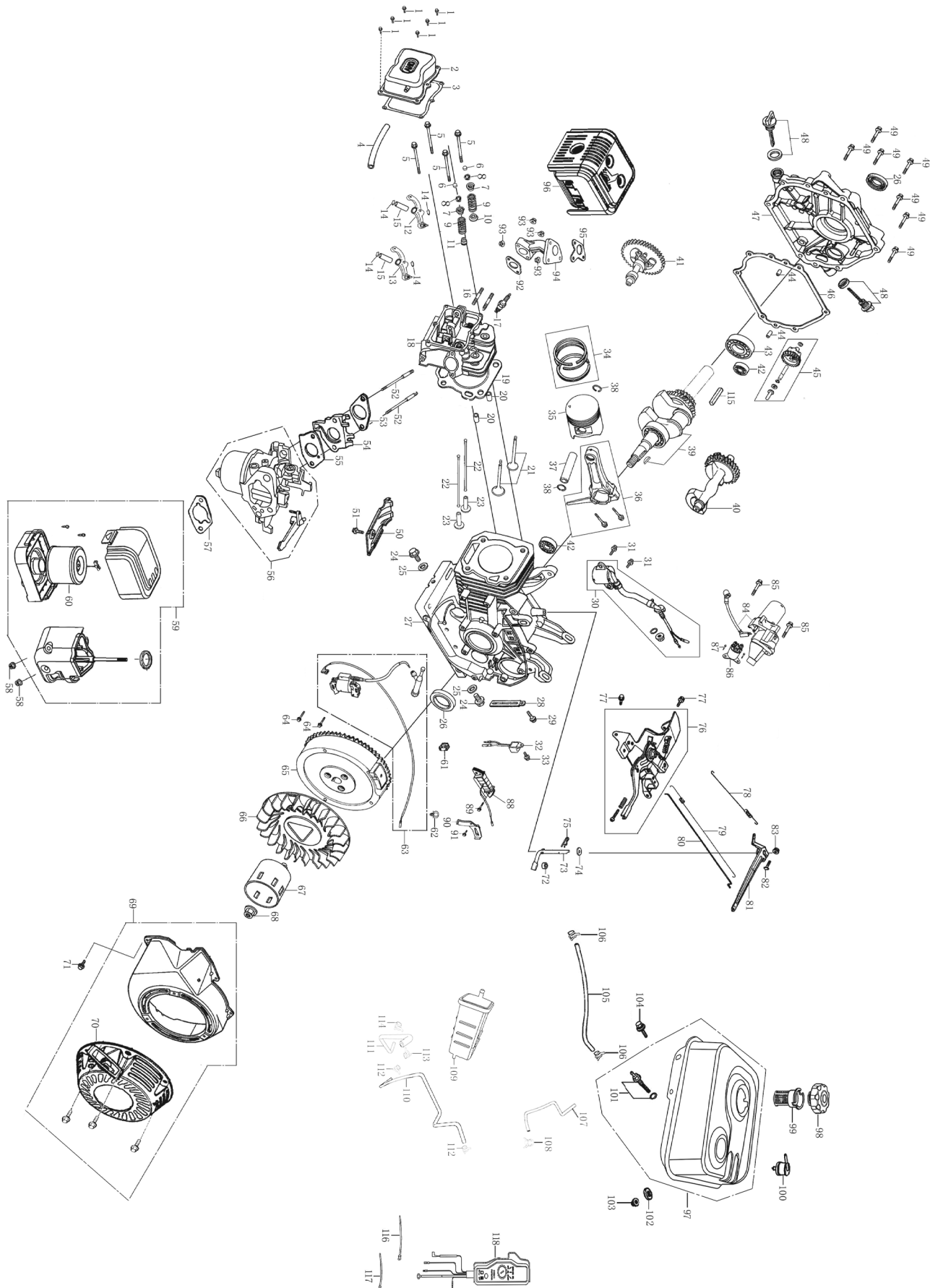

Record Product's Serial Number Here: _____

Note: If product has no serial number, record month and year of purchase instead.

Note: Some parts are listed and shown for illustration purposes only, and are not available individually as replacement parts.

SAFETY

SETUP

OPERATION

MAINTENANCE

PLEASE READ THE FOLLOWING CAREFULLY

THE MANUFACTURER AND/OR DISTRIBUTOR HAS PROVIDED THE PARTS LIST AND ASSEMBLY DIAGRAM IN THIS MANUAL AS A REFERENCE TOOL ONLY. NEITHER THE MANUFACTURER OR DISTRIBUTOR MAKES ANY REPRESENTATION OR WARRANTY OF ANY KIND TO THE BUYER THAT HE OR SHE IS QUALIFIED TO MAKE ANY REPAIRS TO THE PRODUCT, OR THAT HE OR SHE IS QUALIFIED TO REPLACE ANY PARTS OF THE PRODUCT. IN FACT, THE MANUFACTURER AND/OR DISTRIBUTOR EXPRESSLY STATES THAT ALL REPAIRS AND PARTS REPLACEMENTS SHOULD BE UNDERTAKEN BY CERTIFIED AND LICENSED TECHNICIANS, AND NOT BY THE BUYER. THE BUYER ASSUMES ALL RISK AND LIABILITY ARISING OUT OF HIS OR HER REPAIRS TO THE ORIGINAL PRODUCT OR REPLACEMENT PARTS THERETO, OR ARISING OUT OF HIS OR HER INSTALLATION OF REPLACEMENT PARTS THERETO.

PREDATOR[®]
E N G I N E S

3491 Mission Oaks Blvd. • PO Box 6009 • Camarillo, CA 93011 • 1-888-866-5797